



GAME WINNER™
5 lb (3L)
**Vertical Sausage
Stuffer**

MODEL # 73-0501-GW
STYLE # FSGWCO5103



WARNING!

REV071014
Made in China

Read instruction manual before attempting to assemble or operate this product.

For customer service please call 1-800-814-4895 Monday thru Friday 8:00am-5:00pm
EST. Outside the U.S. call 440-638-3131
Email customerservice@westonproducts.com

-OR-

1-888-922-2336 Monday thru Saturday 8:00am-10:00pm, Sunday 9:00am-8:00pm CST
Email: customerservice@academy.com

TABLE OF CONTENTS

General Safety Rules	2
Component List	3-4
Assembly Instructions	5-6
Disassembly & Cleaning Instructions.....	6
Stuffing Instructions	7
Food Safety	8
Sausage Information	9
Warranty Information	10

GENERAL SAFETY RULES



WARNING!

READ AND FULLY UNDERSTAND ALL INSTRUCTIONS AND WARNINGS PRIOR TO USING THIS STUFFER. YOUR SAFETY IS MOST IMPORTANT: FAILURE TO COMPLY WITH PROCEDURES AND SAFE GUARDS MAY RESULT IN SERIOUS INJURY OR PROPERTY DAMAGE. **REMEMBER: YOUR PERSONAL SAFETY IS YOUR RESPONSIBILITY!**

1. Read this owners manual before attempting to assemble or operate the **Vertical Stuffer**.
2. NEVER use any accessories or parts from other manufacturers. Doing so will void your warranty.
3. NEVER store or leave the machine at a temperature lower than 32°F (0°C).
4. Thoroughly clean all parts that will come in contact with food before and after using the appliance. Wash all parts by hand and thoroughly dry.
5. KEEP CHILDREN AWAY! Never leave the stuffer unattended. The **Stuffer** is not a toy.
6. Be sure the **Stuffer** is on a stable work area. Be sure all of the **Stuffer Feet** are level.
7. DO NOT use the **Stuffer** while under the influence of drugs or alcohol.

SAVE THESE INSTRUCTIONS!

Refer to them often and use them to instruct others.

COMPONENT LIST

DIAGRAM NUMBER	PART DESCRIPTION	PART NUMBER
1	Handle with Wingnut (Wingnut only xx-xxxx)	73-0540
2	Frame	73-0541
3	Gear Set (2) and Horizontal Gear Bushing	73-0542
4	Plunger Shaft with Washer	73-0543
5	Plunger Seal	73-0544
6	Pressure Release Valve Kit (3 Piece Set)	73-0545
	Includes:	
	Piston	
	M6 Acorn Nut	
	Plunger	
	Stainless Steel Canister	73-0519-GW
7	Plastic Funnel Set (3 Funnels)	73-0546
8	Front Ring Nut	73-0547
9	Base	73-0548
10	M10 Base Nuts (2) and M10 Base Washers (2)	73-0549
11	Clamps (2)	73-0550

If any components of this unit are broken or do not operate properly, call

1-800-814-4895

Monday thru Friday 8:00am-5:00pm EST. Outside the U.S. call 440-638-3131

E-Mail: customerservice@westonproducts.com

COMPONENTS

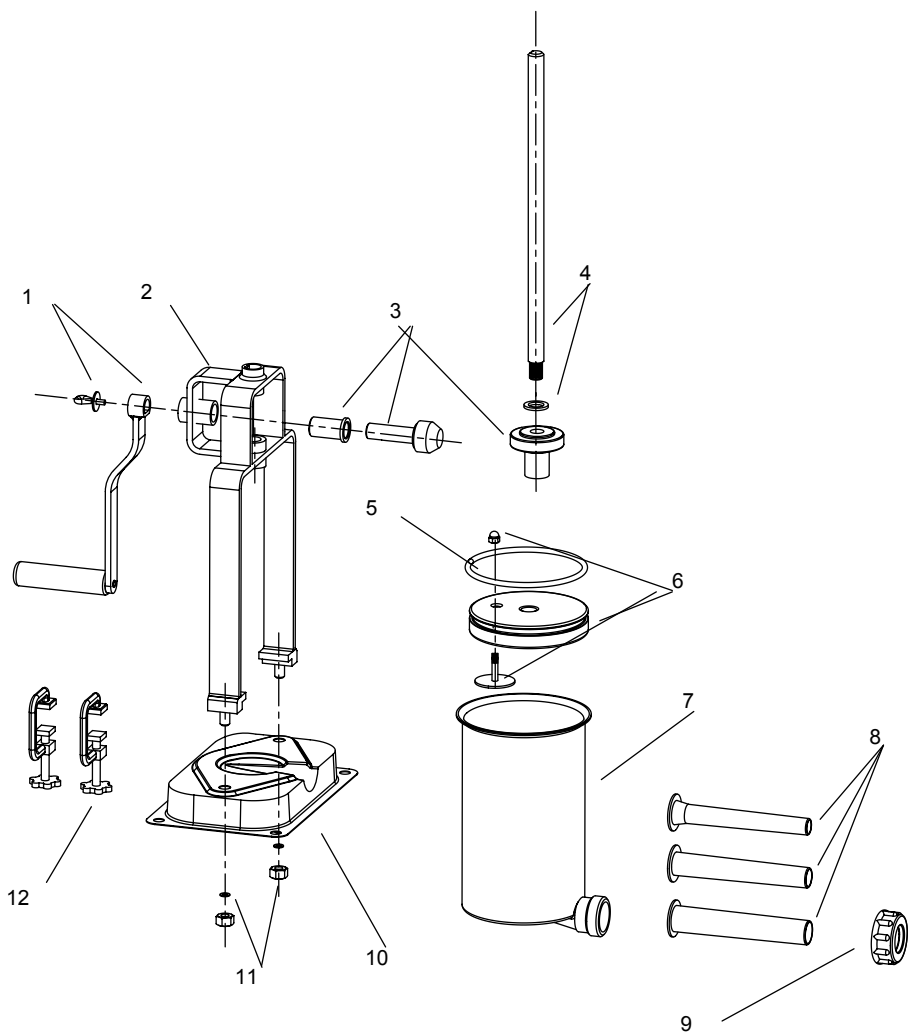

ASSEMBLY

BODY ASSEMBLY

1. Align the **Frame** with the holes in the **Base**. From below the **Base**, slide each **Base Washer** onto the threaded end of the **Frame**. Secure each **Base Washer** with a **Base Nut**. (figure 1).

figure 1

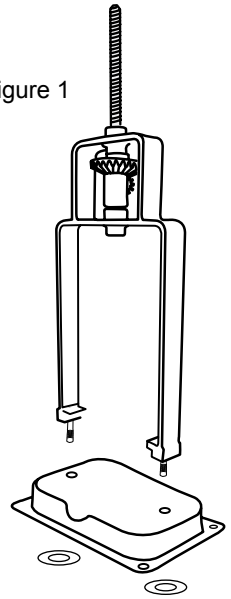

PLUNGER ASSEMBLY

2. Slide the **Plunger Seal** onto the **Plunger Release Valve** (figure 2).

3. Insert the piston through the valve hold. From the top of the **Plunger**, Place the **Acorn Nut** on the threaded end of the piston. NOTE: The piston will feel loose in the **Pressure Release Valve Kit**.

4. Place the assembled **Plunger Release Valve Kit** onto the end of the **Plunger Shaft** (figure 3).

figure 2

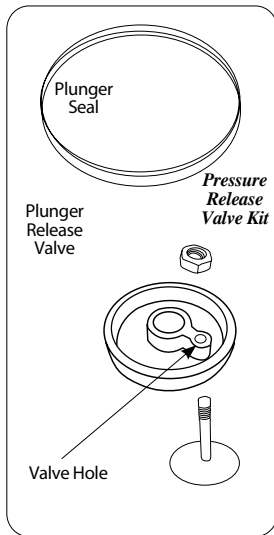
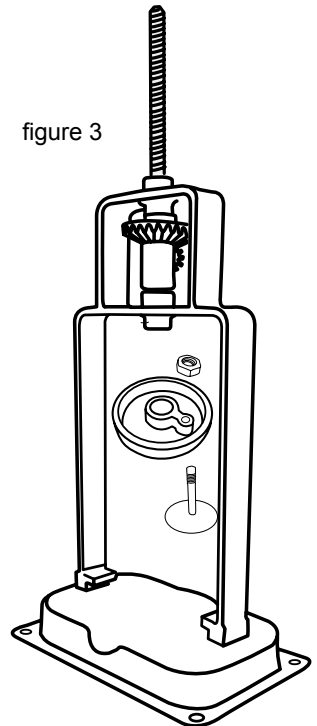

figure 3



STUFFER ASSEMBLY

5. Attach the **Handle** by sliding it onto the **Gear Shaft** and placing the **Wingnut** into the hole in the **Handle**. Twist to tighten (figure 4).

6. Crank the **Handle** counter-clockwise to bring the **Plunger** to the top of the **Stuffer**.

7. Slide the **Notches** at the bottom of the canister into the **Canister Mounts** at the base of the **Frame** (figure 5).

8. Insert the **Stuffing Funnel** of your choice through the **Front Ring Nut**. Screw the **Front Ring Nut** and **Stuffing Funnel** onto the mouth of the **Canister** until snug. **DO NOT OVERTIGHTEN** the **Front Ring Nut**, as it may damage the **Funnel** (figure 6).

9. Position the stuffer so the back edge of the base is close to the table. Secure the clamps so that clamps are angled on the corners of the base.

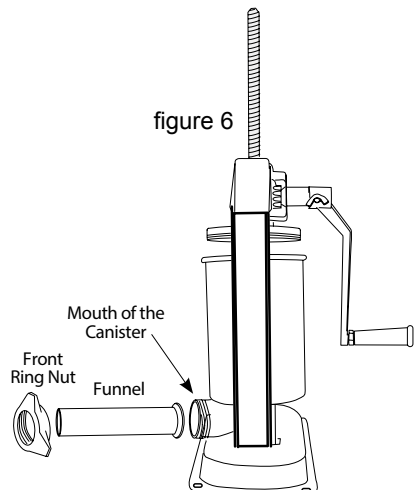
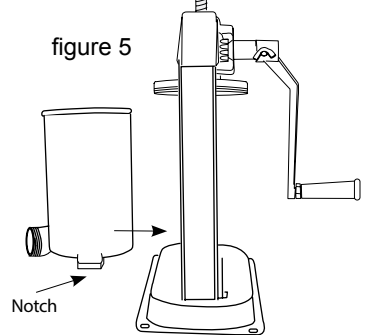
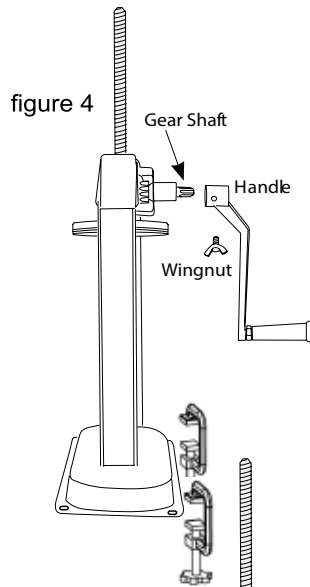

DISASSEMBLY & CLEANING

1. Remove the **Stuffing Funnel** by unscrewing the **Front Ring Nut**, and pulling the **Funnel** out.

2. Turn the **Handle** counter-clockwise until the **Plunger** comes out of the **Canister**.

3. Slide the **Canister** out.

4. Unscrew the **Plunger Release Valve Kit** from the **Plunger Shaft**. Disassemble the **Pressure-Release Valve** from the **Plunger**. Remove the **Plunger Seal** from the **Plunger**.

5. Wash all parts that have come in contact with meat in hot soapy water. **BE SURE TO CLEAN THEM IMMEDIATELY AFTER USE**. Rinse and thoroughly dry all parts **IMMEDIATELY**. Sterilize as needed.

6. Fully lubricate the **Shaft**, **Canister**, **Pressure Release Valve Components** and the **Front Ring Nut** with a food-grade lubricant after each use.

STUFFING INSTRUCTIONS



CAUTION! Any time you complete stuffing or raise the Plunger out of the Canister, **RELEASE THE HANDLE SLOWLY!** Pressure or gravity could cause the Handle to spin back slightly causing injury!

1. Slide out the **Canister**.
2. Fill the **Canister** with your meat and seasoning mixture (figure 7).
3. Press the mixture down into the **Canister** firmly to release any trapped air.
4. Slide the **Notches** at the bottom of the canister into the **Canister Mounts** at the base of the **Frame**.
5. Turn the **Handle** clockwise, until the Plunger comes in contact with the meat and the mixture is ready to extrude out the end of the **Stuffing Funnel**.
6. Slip the casing on the end of the **Stuffing Funnel** until the entire casing has slid onto the **Stuffing Funnel** (figure 8).
7. Tie, twist or hog ring the end of the casing to seal it.
8. Turn the **Handle** clockwise to extrude the mixture into the casing. For best results, apply pressure around the casing, close to the end of the **Stuffing Funnel**. This will hold the casing tight and will cause the mixture to pack firmly into the casing.
9. When the end of the casing has been reached, twist, tie or hog ring the casing to seal the contents inside.

STUFFING TIPS: The following are suggestions to help reduce resistance when stuffing with the **13 mm Stuffing Funnel**.

A. Add water to your meat mixture – up to 1-1/2 cups (0.4 L) of water per every 5 lb (2.3 kg) of seasoned meat.

B. Add 1/4 cup (60 ml) of vegetable or olive oil to the meat mixture for better flow.

figure 7

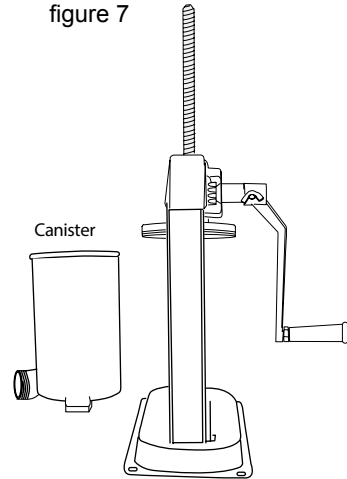
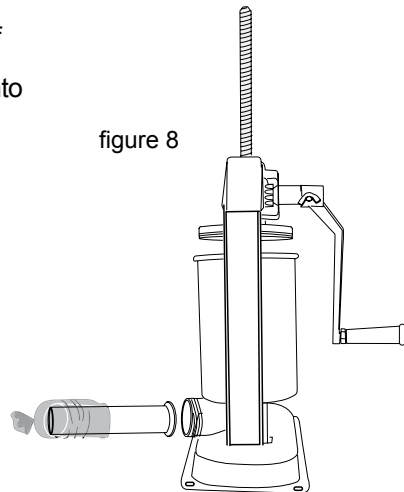

figure 8



FOOD SAFETY

There are basic rules to follow when handling food.
They are **COOK, SEPARATE, CLEAN,** and **CHILL.**

COOK

It's crucial to cook food to a safe internal temperature to destroy bacteria that is present. The safety of hamburgers and other foods made with ground meat has been receiving a lot of attention lately, and with good reason. When meat is ground, the bacteria present on the surface is mixed throughout the ground mixture. If this ground meat is not cooked to at least 160°F to 165°F (71°C to 74°C), bacteria will not be destroyed and there's a good chance you will get sick.

Solid pieces of meat like steaks and chops don't have dangerous bacteria like E. coli on the inside, so they can be served more rare. Still, any beef cut should be cooked to an internal temperature of at least 145°F (63°C) (medium rare). The safe temperature for poultry is 180°F (82°C) and solid cuts of pork should be cooked to 160°F (71°C). Eggs should be thoroughly cooked too. If you are making a meringue or other recipe that uses uncooked eggs, buy specially pasteurized eggs or use prepared meringue powder.

SEPARATE

Foods that will be eaten uncooked and foods that will be cooked before eating **MUST ALWAYS** be separated. Cross-contamination occurs when raw meats or eggs come in contact with foods that will be eaten uncooked. This is a major source of food poisoning. Always double-wrap raw meats and place them on the lowest shelf in the refrigerator so there is no way juices can drip onto fresh produce. Then use the raw meats within 1-2 days of purchase, or freeze for longer storage. Defrost frozen meats in the refrigerator, not on the counter.

When grilling or cooking raw meats or fish, make sure to place the cooked meat on a clean platter. Don't use the same platter you used to carry the food out to the grill. Wash the utensils used in grilling after the food is turned for the last time on the grill, as well as spatulas and spoons used for stir-frying or turning meat as it cooks.

Make sure to wash your hands after handling raw meats or raw eggs. Washing hands with soap and water, or using a pre-moistened antibacterial towelette is absolutely necessary after you have touched raw meat or raw eggs. Not washing hands and surfaces while cooking is a major cause of cross-contamination.

CLEAN

Wash your hands and work surfaces frequently when you are cooking. Washing with soap and warm water for at least 15 seconds, then dry with a paper towel.

CHILL

Chilling food is very important. The danger zone where bacteria multiply is between 40°F and 140°F (4°C and 6°C). Your refrigerator should be set to 40°F (4°C) or below; your freezer should be 0°F (-17°C) or below. Simple rule: serve hot foods hot, cold foods cold. Use chafing dishes or hot plates to keep food hot while serving. Use ice water baths to keep cold foods cold. Never let any food sit at room temperature for more than 2 hours - 1 hour if the ambient temperature is 90°F (32°C) or above. When packing for a picnic, make sure the foods are already chilled when they go into the insulated hamper. The hamper won't chill food - it just keeps food cold when properly packed with ice. Hot cooked foods should be placed in shallow containers and immediately refrigerated so they cool rapidly. Make sure to cover foods after they are cool.

NOTE: Special considerations must be made when using venison or other wild game, since it can become heavily contaminated during field dressing. Venison is often held at temperatures that could potentially allow bacteria to grow, such as when it is being transported. Refer to the USDA Meat and Poultry Department for further questions or information on meat and food safety.

SAUSAGE INFORMATION

MEAT SELECTION FOR SAUSAGE MAKING

Sausage making has evolved over many years and generations, and as a result there are countless types of sausage you can make using the basic ingredients of meat, fat and a few carefully blended spices. Following are a few simple guidelines that will help you make the best tasting sausage possible.

Any type of meat can be used for making sausage: pork, beef, bison, moose and caribou, even antelope make great sausage. It is important when preparing venison or other red game meats to trim all the fat from the meat, as red game tallow will turn rancid in as few as five days. Replace the fat with either pork or beef fat, depending on the type of product you are making, at a ratio of 1 pound (0.5 kg) of fat for every 4 pounds (1.8 kg) of game meat.

The fat content of your sausage will affect the taste, texture, cooking characteristics and shelf life of your product. Most commercially made sausage has a fat content of about 20%. Using less than 12% fat will result in a very dry tasting sausage, while using more than 20% may result in a sticky flavorless sausage that will be difficult to cook.

CURING

It is important to properly cure meats to preserve meat and poultry, and to destroy undesirable microorganisms on the meat surfaces that cause spoilage and food born illnesses. There are many steps that help in this process, including smoking, cooking, drying, chilling and the addition of cure ingredients. The oldest means of accomplishing this is by introducing salt into the meat. The resistance of bacteria to salt varies widely among different types of bacteria. The growth of some bacteria is inhibited by salt concentrations as low as 3%, e.g., Salmonella, whereas other types are able to survive in much higher salt concentrations, e.g., Staphylococcus. Fortunately, the growth of many undesirable organisms normally found in cured meat and poultry products is inhibited at low concentrations of salt.

Modern curing is based on Nitrates and is very scientific. The best way to ensure proper curing is to purchase one of the many commercially available curing agents from either a grocery store or your local butcher. A very common cure is Prague Powder, which is available in two types (#1 and #2).

CASING

There are many different types of casings available, the right choice depends on personal preference as well as the type of sausage you wish to make. For most sausages, your choices are natural or collagen. Don't let the names fool you; collagen casings are not a synthetic product. They are made from beef skin and other tissues. Collagen casings are uniform in size and texture and require almost no preparation. "Natural" casings are the intestines of lamb, sheep, hogs or beef. They are less uniform in size and require substantial preparation. For those reasons, more than 75% of commercially made sausage in the U.S. is made with collagen casing. There are also fibrous non-edible casings that are used for some varieties of smoked sausages and bolognas.

TYPES OF SAUSAGE

Most sausages fall into one of four categories: Fresh, Smoked, Cooked or Dried. All sausages, except dried, require refrigerated storage. There is also a sub-category of uncooked smoked sausages.

Among the fresh and uncooked smoked sausages, you will find such flavors as kielbasa or Polish sausage, Italian sausage, breakfast sausage and many others. Both fresh and uncooked smoked sausages require cooking before eating and also require refrigerated storage.

Smoked and cooked sausages include salami, bologna, the ever-popular hot dogs and many others. Proper smoking requires a smokehouse or smoker. These can be simple home-built structures made from metal drums or even old refrigerators or they can be elaborate manufactured units. Most smoked sausages are warmed before serving.

WESTON WARRANTY INFORMATION

SAVE THIS WARRANTY INFORMATION FOR YOUR RECORDS!

Weston Products LLC warrants to the ORIGINAL RETAIL PURCHASER of this product that if operated in accordance with the printed instruction accompanying it, then for a period of 1 year from the date of purchase, the product shall be free from defects in material and workmanship.

The Warranty Card, along with a copy of the original receipt, must be received by Weston Products LLC within 30 days from purchase date for the warranty to apply. Failure to send the completely filled out Warranty Card, along with a copy of the original receipt, will void the warranty.

The product must be delivered to or shipped freight prepaid to Weston Products LLC for warranty services, in either its original packaging or similar packaging affording an equal degree of protection. Damage due to shipping is not the responsibility of the company. Weston Products LLC charges a \$35.00 per hour bench charge. **NOTE:** No repairs will be started without the authorization of the customer. The return shipping cost to the customer will be added to the repair invoice.

Weston Products LLC will repair (or at its discretion, replace) the product free of charge, if in the judgment of the company, it has been proven to be defective as to seller's labor and material, within the warranty period.

New or rebuilt replacements for factory defective parts will be supplied for one (1) year from the date of purchase. Replacement parts are warranted for the remainder of the original warranty period.

For non-warranty repairs, contact Weston Products LLC's Customer Service at 1-800-814-4895 M-F 8am-5pm EST (outside of the United States 440-638-3131) to obtain a Return Merchandise Authorization Number (RMA Number). Weston Products LLC will refuse all returns that do not contain this number. **DO NOT RETURN THE UNIT WITHOUT PROPER AUTHORIZATION FROM WESTON PRODUCTS LLC.**

LIMITATIONS: The warranty is void if the product is used for any purpose other than that for which it is designed. The product must not have been previously altered, repaired, or serviced by anyone else other than Weston Products LLC. If applicable, the serial number must not have been altered or removed. The product must not have been subjected to accident in transit or while in the customer's possession, misused, abused, or operated contrary to the instructions contained in the instruction manual. This includes failure caused by neglect of reasonable and necessary maintenance, improper line voltage and acts of nature. This warranty is not transferable and applies only to U.S. and Canadian sales.

Except to the extent prohibited by applicable law, no other warranties whether expressed or implied, including warranty merchantability and fitness for a particular purpose, shall apply to this product. Under no circumstances shall Weston Products LLC be liable for consequential damages sustained in connection with said product and Weston Products LLC neither assumes nor authorizes any representative or other person to assume for it any obligation or liability other than such as is expressly set forth herein. Any applicable implied warranties are also limited to the one (1) year period of the limited warranty.

This warranty covers only the product and its specific parts, not the food or other products processed in it.

CUT ALONG THE DOTTED LINE AND SEND THE WARRANTY CARD ALONG WITH A COPY OF YOUR ORIGINAL PURCHASE RECEIPT TO:

Weston Products LLC
20365 Progress Drive, Strongsville, OH 44149

WESTON WARRANTY CARD

SEND THIS CARD ALONG WITH A COPY OF YOUR ORIGINAL PURCHASE RECEIPT TO:
WESTON WARRANTY, WESTON PRODUCTS LLC, 20365 PROGRESS DRIVE, STRONGSVILLE, OH 44149

Customer Name: _____

Address: _____

City/State/Zip: _____

Telephone Number: (_____) _____

E-Mail Address: _____

Original Date of Purchase: ____/____/____

Product Model #: _____

Serial # (if applicable): _____



GAME WINNER





GAME WINNER™

**WESTON®
PRODUCTS**

ATTENTION!

If any components of this unit are broken, do not operate properly, or for product returns, please contact Weston Products LLC

Phone: 1-800-814-4895 (Outside the U.S. 440-638-3131)

Mail: 20365 Progress Drive, Strongsville, Ohio 44149

E-Mail: CustomerService@WestonProducts.com

Web Site: WestonProducts.com

All Trademarks and Registered Trademarks are property of the respective companies.

SAVE THESE INSTRUCTIONS!

Refer to them often and use them to instruct others.