



50 Customer Service Training Activities for Live Chat and Telephone Teams

Contents

Introduction	4
About These Activities	4
Focus.....	5
A Tangled Web.....	9
Animal Magic	10
Are You Listening?	11
Attitude Anchors.....	14
Better Together	16
Blind Drivers.....	18
Candid Camera.....	19
Catch!.....	20
Compelling Communication.....	21
Consensus	22
Conversation Rewind	23
Customer Service Alphabet.....	24
Customer Service Charades	25
Customer Service Coat of Arms	26
Customer Service Means.....	28
Customer Service Superheroes	29

Drawing Blind.....	30
Empathy Bingo	39
Famous Communicators	43
Football Fun	44
Four Square.....	46
Fresh Perspectives	47
HEARD Roleplay	48
Let Me Tell You What I Can Do	49
Marshmallow Challenge	50
Mission Possible.....	51
Movie Madness.....	52
Pipe Cleaner Sculpture	53
Protectors and Enemies	54
Questions Only.....	55
Road Trip.....	56
Salt and Pepper.....	57
Say My Name	59
Show and Tell.....	60
Step into the Difficult Customer’s Shoes.....	61
Stuck in Quicksand	62

Telephone	64
The Bus Driver.....	66
The Change Challenge.....	67
The Curse of Knowledge	69
The Dress	70
The Egg Drop.....	72
The Stranger Challenge	73
Thoughts, Feelings, Behavior	74
Touch Something Green	76
True, True, False	77
Unique Perspectives	78
Values in Action	79
What Are You Doing?.....	81
Worst Case Scenario	82
Write Customer Letters	83
About Comm100.....	84
Customers	84
Accreditations	84
Contact Us	84

Introduction

21st century customer service is tougher and more demanding than ever. The drive to increase the efficiency of your staff, paired with the need for them to continuously improve their skills, means that fitting in truly effective training can be difficult.

This eBook has been designed with tried and tested activities which are simple to deliver and require practically zero preparation or equipment. They deliver powerful messages and come with suggested debriefs, so you can be sure that key messages are being heard and understood loud and clear.

All of these activities can be used by two types of people:

1. Managers or supervisors who need to improve customer service or morale in their teams
2. Trainers, whether they have experience or not, who need to fill short gaps in existing programs with fun and effective, yet topic-relevant activities

It doesn't matter whether you've delivered training activities ten times or ten thousand times, if you are looking to deliver insightful customer service messages, you will be able to find something here which works for your team.

About These Activities

When running a training activity, there are a few fundamental points which are important to consider.

- **Be adaptable.** None of these activities will only work the way they have been set out here. If you can think of a variation which would work really well for your particular business or illustrate a particular learning point you want to focus on, go for it.
- **Know your audience.** If there is an activity here that you think might not work so well with your team, adapt it or don't use it. You also need to be happy to deliver these activities comfortably yourself. Beware of any training which might make participants feel awkward or uncomfortable, including yourself.
- **Facilitate, don't preach.** Learning works best when you can help your group figure out answers and connections by themselves, not when you just tell them what you need them to know. Don't be afraid to ask questions and dig deeply into their statements to allow your team to draw out information which is important. If this feels unnatural to you, there are plenty of suggested questions within these activities to help you with this.

- **Always debrief.** It can seem obvious to you how a game has parallels with real life customer service, but it may not be so obvious to your team. A solid debrief is essential to link the activity to learning, and to give your team some ideas as to how they can apply the learning to the workplace. All of the activities here have suggested debriefs so you can make these links clearly.

At Comm100 we love to hear about your experiences and successes with these activities – please let us know how they work for you!

Focus

Although each of these activities work brilliantly as general customer service training activities, there may be times you want to focus on a particular area of learning. The below table shows which activities cover certain areas especially well.

Additionally, some activities are especially short and fun so are ideal for running as energizers, to raise energy levels during the course of a day or when a team has returned from a break. These are also marked here.

Activity Title	Energizer	Teamwork	Communication	Questioning Techniques	Listening Skills	Self-Awareness	Best Practice	Difficult Customers	Empathy	Page Number
A Tangled Web	X	X								9
Animal Magic	X	X								10
Are you Listening?			X		X					11
Attitude Anchors						X				14
Better Together		X	X							16
Blind Drivers	X		X							18
Candid Camera		X			X					19
Catch!	X	X								20

Activity Title	Energizer	Teamwork	Communication	Questioning Techniques	Listening Skills	Self-Awareness	Best Practice	Difficult Customers	Empathy	Page Number
Compelling Communication			X				X			21
Conversation Rewind			X				X			23
Customer Service Alphabet		X					X			24
Customer Service Charades	X		X							25
Customer Service Coat of Arms		X					X			26
Customer Service Means...		X					X			28
Customer Service Superheroes		X					X			29
Drawing Blind			X	X						30
Empathy Bingo			X					X		39
Famous Communicators	X		X							41
Football Fun	X									44
Four Square	X						X			46
Fresh Perspectives						X			X	47
HEARD Roleplay			X					X		48
Let Me Tell You What I Can Do			X	X						49

Activity Title	Energizer	Teamwork	Communication	Questioning Techniques	Listening Skills	Self-Awareness	Best Practice	Difficult Customers	Empathy	Page Number
Marshmallow Challenge		X	X							50
Mission Possible	X						X			51
Movie Madness	X		X							52
Pipe Cleaner Sculpture	X	X								53
Protectors and Enemies	X									54
Questions Only	X			X						55
Road Trip		X	X							56
Salt and Pepper			X	X						57
Say My Name		X			X					59
Show and Tell							X	X		60
Step into the Difficult Customer's Shoes								X	X	61
Stuck in Quicksand			X						X	62
Telephone			X		X					64
The Bus Driver			X		X					66
The Change Challenge		X	X							67
The Curse of Knowledge			X		X					69
The Dress						X			X	70
The Egg Drop		X								72

Activity Title	Energizer	Teamwork	Communication	Questioning Techniques	Listening Skills	Self-Awareness	Best Practice	Difficult Customers	Empathy	Page Number
The Stranger Challenge		X	X							73
Thoughts, Feelings, Behavior						X			X	74
Touch Something Green	X									76
True, True, False	X	X								77
Unique Perspectives		X				X				78
Values In Action		X					X			79
What are you doing?			X							81
Worst case scenario							X	X		82
Write Customer Letters		X					X			83

A Tangled Web

DEBRIEF

Great teams are made through both their similarities and their differences. In this activity we've been able to see the huge number of different ways we can relate to each other, while also recognizing that there are lots of things that make us unique. In that sense, we're all connected in different ways – and that's what really makes for effective teams.

Focus	Duration	What You'll Need
Teamwork, Energizer	15-30 minutes	A ball of yarn

This activity is adapted from mftrou.com.

A Tangled Web is an activity that everyone can participate in together, making it an exceptional team building activity.

Have everyone stand up in a circle, facing inward. The first person is to hold the ball of yarn in his or her hands, and then state a fact about themselves. (For example, "My favorite food is sushi.")

Everyone who relates or agrees to that statement raises their hand. The first hand the yarn-holding individual sees will get the rest of the yarn. He or she will hand the ball to this person, while still holding on to an end of the yarn.

At the end (and after a number of chuckles), you'll find that the web is incredibly tangled—proving the importance of your interconnected team.

Animal Magic

DEBRIEF

None needed, as this activity works best when it's done as an energizer just for fun – although you could potentially draw some parallels to barriers in communication.

Focus	Duration	What You'll Need
-------	----------	------------------

Teamwork, Energizer	5 minutes	Nothing
---------------------	-----------	---------

Ask your team to silently think of their favorite animal.

Then, ask them to get in a line, with the biggest animals at one end and the smallest animals at the other. The only catch is – team members can only organize themselves by making the sounds and performing the actions of their chosen animal!

Tell the team to start and watch the fun!

Once the team have finished, ask them to call out their chosen animals to see if they guessed correctly.

Are You Listening?

DEBRIEF

Listening empathetically all the time is really tough, especially considering the amount of distractions we have going on around us in the office. But having an awareness of lower levels of listening allows you to notice the instances you might be doing it. Practice your empathetic listening skills today and try to work out what things you can do to listen more openly and actively to your customers, as often as you can.

Focus	Duration	What You'll Need
Communication, Listening Skills	10 minutes	Listening levels handout (on next page), Cards or paper numbered 1-5

This is a great activity to get your team thinking about how deeply we listen in the course of our everyday communications.

Explain to your team that whenever another person is speaking to us, we will always listen to them at one of five different levels.

Give them the handout, or draw up the diagram on a whiteboard or flipchart, and talk them through the different levels.

Now, split the team in half. One half of the team are speakers, the other half are listeners.

Give the listeners a card each so there is an even mix of numbers, and ask them not to disclose the number on the card. Explain that the number on the card correlates to a level of listening, and the listener's job is to model this style of listening while they are being spoken to. 1s should ignore the people who are speaking to them, 5s should listen empathetically, and so on.

Ask the speakers to speak to any of the listeners about any topic that interests them – be it work-related, the weather, or anything else. Their job is to guess the listening level of as many people in the room as possible.

Give the team five minutes to move around the room, speaking and listening to each other. You should hear some laughter as ignorers try to be absolutely disconnected, and others on lower levels try to distract others from their conversations!

Bring the group back together and ask who thought they guessed the most. Listeners should then show their numbers to see who guessed right.

Ask the speakers how the exercise felt. They will comment that it feels bad and is difficult to talk when another person isn't really listening, and that empathetic listening encouraged them to talk more.

Now, ask the listeners how that exercise felt. Those on lower numbers will probably comment that the exercise was quite easy but didn't feel very good! Those on higher numbers will probably comment that it's quite hard to listen empathetically, especially when there were so many distractions around them.

The Five Levels of Listening

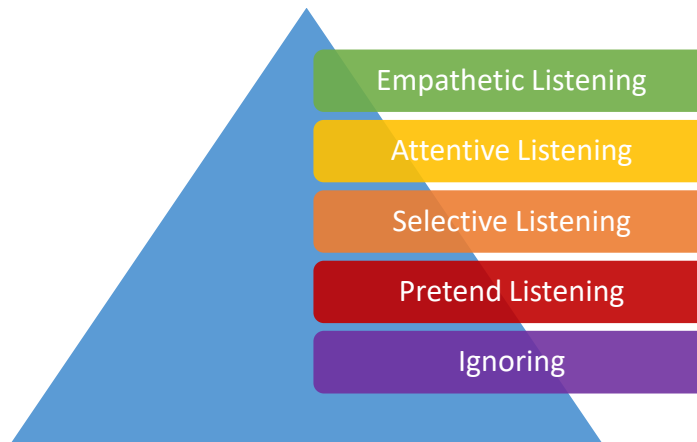

Ignoring is being so distracted you are not listening to the other person at all – for example, a customer is talking but another colleague is trying to talk to you at the same time, and you are focused on the conversation with your colleague.

Pretend Listening is when you are giving the impression that you’re listening to the other person – for example, by saying “I see” or “OK” to a customer as they are talking, while you are actually focused on writing an email.

Selective Listening is when you are only listening out for things you want to hear, agree with, or like to hear from the other person – for example, switching off when a customer starts talking at length about something you find uninteresting, or jumping to conclusions about what a customer needs as soon as they say something that sounds like a familiar issue, without taking the time to really hear them.

Attentive Listening is one of the most common levels of questioning we all use. It happens when you are listening to another person, but internally you are thinking about what you are going to say next – whether you agree or disagree, and how you will reply to what they’re saying. An example would be when a customer is talking about an issue, you feel you have got a handle on what they need but you are so busy figuring out what you’re going to say next you’re not fully considering their situation.

Empathetic Listening is the most difficult level of listening as it requires you to remove your own perspective from the conversation, put yourself in the other person’s shoes, and listen to the other person from their perspective. An example would be when a customer is calling about an issue that is familiar to you, but you can understand how familiar and confusing the issue might be to them, and listen carefully for things they are saying which allow you to see the problem through their eyes.

Attitude Anchors

DEBRIEF

When you're in a negative mood, it can be really tough to pull yourself out of it. Often, we wait for something to happen to us to change our mood, but if you proactively use an attitude anchor to help you, you can often stop it in its tracks. Use this worksheet to remind you of the things that help you to feel good, or that will put a smile back on your face after a difficult interaction.

Focus	Duration	What You'll Need
Self-Awareness	5-10 minutes	Attitude Anchors worksheets (on next page) and pens

The concept of an [attitude anchor](#) is an activity or thing that helps you maintain the awesome attitude you need in order to be effective in customer service.

There are two attitude anchors: maintenance anchors, which help you maintain a positive attitude, and repair anchors, which help you fix your bad moods.

Hand out the worksheets which will prompt your group to think about and write down their anchors. They may be small things, like going for a walk or drinking some tea—encourage your agents to think about little things that help them elevate their mood.

Then ask your group to share some of their ideas, so that everyone can borrow each other's ideas if they find they are lacking in anchors.



Attitude Anchors



What **recovery anchors** can I use to get me back on my feet when I'm feeling stressed?

What **maintenance anchors** can I use to stop me getting stressed in the first place?

Better Together

DEBRIEF

Hopefully we all recognize that we're better when we work together. By harnessing the added power that comes from collaboration, we can create better results not just in remembering lists of words, but in fixing issues for our customers. Next time you're in a situation that you're not sure of the answer to, don't try to go it alone – remember you have the backup, knowledge and experience of everyone here to help you create even better and stronger solutions.

Focus	Duration	What You'll Need
Teamwork, Communication	10 minutes	Printed word list (on next page) pens and paper

The best teams collaborate to get results. This activity emphasizes the importance of collaboration in meeting team goals.

Print out the list of 30 objects for your team to look at (on the next page) or you can use the image as a slide to be projected. Feel free to replace any or all of the objects with items relevant to your workplace.

Give each team member a pen and paper. Explain that you will be showing them a list of 30 objects, which they will look at for 30 seconds only.

Without writing down any of the words while they are looking at them, their job will be to remember as many of the objects as possible once the list has been taken away.

Give the team 30 seconds to remember the items on the list, then give them another minute or so to write down as many as they can remember. Once finished, ask them how many they remembered. Congratulate the person who remembered the most.

Next, ask the team to compare lists to come up with a master list of objects.

Finally, show the list of objects again to see how many the team got right. The amount they had remembered together will be a lot more than they had remembered individually!

During the debrief, be sure to recognize any instances that team members naturally bounced ideas off each other, during the first stage of the activity before they had been asked to collaborate.

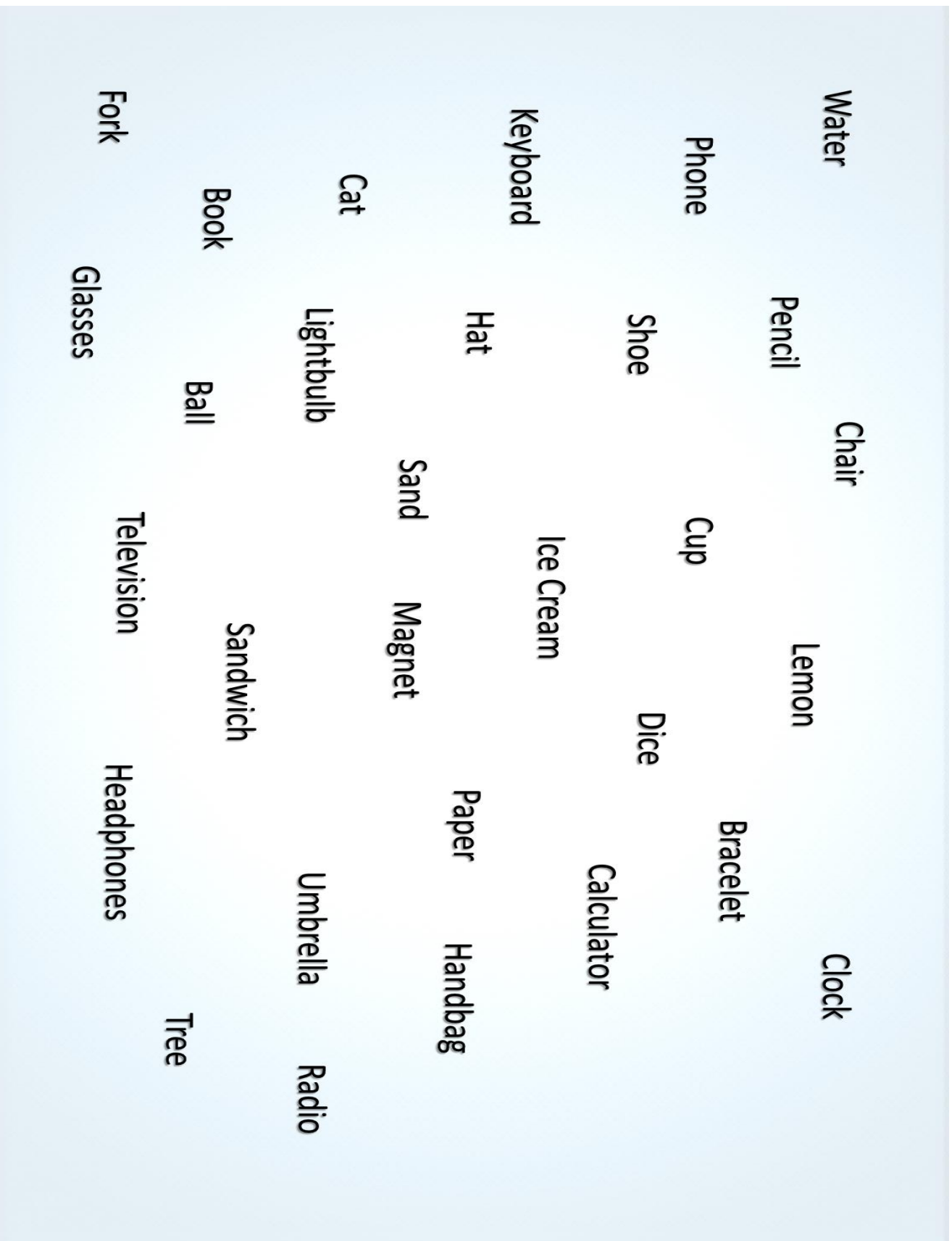

Blind Drivers

DEBRIEF

Often, our customers come to us because they're not sure about something, or they want help. They're missing information, which we need to provide to give them a level of comfort and certainty. Being a customer can be like being a blind driver – it can take a really skilled agent to be able to clearly guide a customer through interactions with us, so they can trust in where they're going.

Focus	Duration	What You'll Need
-------	----------	------------------

Communication,
Energizer

10 minutes

Blindfolds

Split your team into pairs.

Explain to the team that one of them will be a driver, and one a driving instructor. Let them decide quickly who is who.

Explain that the catch is that the driver will be blindfolded. Hand out a blindfold to each pair.

The job of the driving instructor is to guide the driver around the room, avoiding any obstacles.

Tell the pairs to start, and watch them guide each other around. If the pairs seem to be finding the activity quite easy, you can create obstacles while the activity is occurring, by putting chairs in the way or even lying down on the floor.

Stop the activity when you wish. If you have enough time, you can repeat the activity, asking the pairs to swap roles.

- Once you are totally finished, ask the group a few questions.
- Drivers – how did you find that activity?
- Driving instructors – how did you find that activity?
- Was the driving, overall, a success?
- Was there anything you could have done differently to make it more successful?
- How does this relate to the way we guide our customers through communications with us?

Candid Camera

DEBRIEF

None needed for this activity, as it speaks for itself – you may want to simply draw some parallels between remembering names effectively, and good customer outcomes through the easier formation of rapport.

Focus	Duration	What You'll Need
Teamwork, Listening Skills	15-20 minutes	Pictures of each team member/character, and a recall test

This activity is adapted from [The Big Book of Team Building Games](#).

This activity drives home the point that customer service representatives need to remember who they're talking to at all times.

Ask each team member to state their name.

If you are running this activity online, have each team member share a picture of themselves in a group chat as they state their name.

If you are all well-acquainted with one another, have each team member create a customer persona, with a fake name and a picture of a celebrity.

Then hand out or email a test. Encourage team members to turn it in within two minutes—then share the answers. The key here is to test how quickly team members can learn names.

Additionally, this [memory game](#) created by the BBC is a great resource to send to your team members if they're having trouble remembering names or faces.

Catch!

DEBRIEF

By drawing on comments and statements discussed that you found interesting, linking these to wider company themes and values.

Focus	Duration	What You'll Need
-------	----------	------------------

Energizer, Teamwork	As long as you like	A ball
---------------------	---------------------	--------

This is a simple energizer which can be adapted for whatever area you wish to focus on. You can use our suggested questions, or make up your own, to tie in with a particular theme or idea.

Ask your team to stand in a circle. You can take the role of leader for the first round, starting off by holding the ball. Think of a question you'd like to ask the group, for example, "What does customer service mean to you?"

Answer the question and explain that each person to get the ball needs to also answer the question. Throw the ball to a member of the team and ask them to answer, then ask them to throw the ball to repeat the process until everyone has answered.

Once one round has been completed, get the ball back and pose a new question. You can do this for as many rounds as you like. Thought-provoking questions for subsequent rounds are:

- What does exceptional customer service look like?
- What is your customer service philosophy?
- What's the best way to handle a difficult customer?
- How do you know you're delivering great service?
- Share a time you received exceptional customer service. What happened, and what made it so special?

Alternatively, if you want an energizer just for fun, you can come up with some non-work-related questions. You can even tell your group that they can change the question being asked any time they like, when they have the ball, and let them take charge of asking and answering each other fun questions.

Compelling Communication

DEBRIEF

There are a lot of constraints and differences when dealing with customers across different channels. Communication is a process, and it is subject to barriers – the barriers imposed by a method of communication can make all the difference in whether your message has been received and understood, or misinterpreted. If there is a tip or hint here that you hadn't considered previously, write it on a post it note or somewhere you'll be able to see it back at your desk, so you can give it a try next time you're speaking to a customer.

Focus	Duration	What You'll Need
Communication, Best Practice	25 minutes	Pens and paper

This activity is a great one for helping multi-channel teams examine the ways they will need to change their communication style across channels.

Split your team into three. Assign a different communication method for each team – one could be face to face, one could be telephone, and one could be email and live chat. Explain that each group will be exploring the pros and cons of a variety of different communication methods.

Within each group, ask them to get into pairs.

The group examining face to face communication are, in their pairs, to have a normal conversation with no restrictions.

The group examining telephone communication will be simulating this by sitting in pairs, back to back. They will not be able to see each other, but can hear each other.

Finally, the group examining email/live chat will need to sit back to back, but only communicate through messages written on pen and paper.

Based on their conversations, they will need to collectively write a list of pros, cons, and suggested best practices.

Give each group five minutes to communicate with each other, then once the time is up, ask them to start on their lists. Give them ten minutes or so to do this.

Bring the team back together and ask each group to present their findings. Capture key observations on a whiteboard or flip chart.

Consensus

DEBRIEF

It's easy, in a training activity, to think that we never communicate this way at work. But think about all the different ways we do communicate and the problems that may come with these different methods. Are emails always clear? Are messages sent through always received the way they were intended? Do we always remember or have time to consult with all stakeholders when making a decision? In this activity, the whole object of the game would have been much easier if we'd been able to sit down and plan out what we were doing ahead of time. This applies to the workplace, too – collaborating before an event is much easier than trying to reach consensus on the fly.

Focus	Duration	What You'll Need
Energizer, Teamwork	10 minutes	Nothing

This activity is a good one to examine the role of inter-team communication and silos, although it's also a great activity when done just for fun. It works best for larger groups of ten or more.

Divide your team up into three or four groups (preferably with three or more people in each group.)

Each group needs to huddle together and come up with a noise and an action to perform for the rest of the groups. This can be anything, encourage them to be creative!

Ask each group in turn to demonstrate their chosen noise and action.

The object of the game is for all of the groups to end up doing the same noise and action at the same time, without having consulted each other.

Give them a few seconds to huddle and decide what noise/action to make. Then, count down from five, and on go, all teams need to make their chosen noise/action.

Repeat the process until all groups are doing the same noise/action. If by chance the groups succeed on the first or second try, break them up into smaller groups and repeat the activity.

Reassemble the team and ask them a few questions:

- How did that activity feel?
- Why was reaching consensus so difficult?
- How did you make decisions, as a group?
- How did it feel not being able to communicate with the other groups?

Conversation Rewind

DEBRIEF

Think about how you felt when you were on the receiving end of these phrases – it doesn't make you feel good to be communicated with in a rude or dismissive way. It's important to remember that even in situations where we can't necessarily give a customer what we need, we can still treat them with empathy and respect and work with them to find alternatives which suit their needs. So next time you're struggling to find a solution for a customer, remember the scenarios we have discussed today, put yourself in your customer's shoes and consider the impact of the things you're saying. You can't rewind a conversation – so take the time you need to get it right, first time round.

Focus	Duration	What You'll Need
Communication, Best Practice	30 minutes	Pens and paper/index card

Hand each of your team members a piece of paper or an index card.

Ask them to write down a customer service word or phrase that they hate. It could be something that has been said to them in a customer interaction they have had personally, something they have heard in the past, or something they have heard from a friend or family member.

Once done, each team member should hand the cards back to you. Split the team into smaller groups (no larger than three or four), mix up the index cards and distribute an even number to each group.

Ask the groups to think about how the statement could be rephrased.

Give the groups ten minutes to have a conversation about each statement, then ask them to share their ideas. If needed, you can ask the writer of each statement to share a little of the context around each situation.

Customer Service Alphabet

DEBRIEF

Hopefully you should all be familiar with the concepts here. But if there's anything here that you're not so familiar with or that you're not sure you do consistently, I challenge you to do some research and find out how you can build this into your interactions. You can do some Googling of any of these concepts, ask me, or ask the colleague who suggested it a little more about how they apply this to help make their work better.

Focus	Duration	What You'll Need
Best Practice, Teamwork	10 minutes	Flipchart/whiteboard and pens

This is an easy activity that gets your team thinking about which values, attributes and behaviors make great customer service.

Prepare by drawing up the alphabet in columns on a flipchart or whiteboard, with spaces next to each letter to write a word or short phrase.

Give your team pens and ask all them to think of one positive customer service value, attribute, phrase or behavior beginning with every letter of the alphabet. For example, A might be Accountability. B could be Building rapport.

Ask them to do this for each letter of the alphabet, writing the words on the board next to their letters. If they get stuck on letter like X or Z, tell them they can use words containing X or Z instead (you can use eXceeding expectations and analyZe needs if they get totally stuck.)

Customer Service Charades

DEBRIEF

Sometimes we encounter situations where customers only give us a piece of the puzzle, and we have to guess what they need through careful questioning. Even where a customer is being quite clear, if we're not communicating face to face we may be disadvantaged by not being able to see their body language or, in the case of email and live chat, hear the tone of their voice. Charades can be a fun way to consider the impact of missing information from our communications – when you're speaking to your customers today, think about what information could be missing from your communications, and come up with some strategies to bridge the gap to ensure crystal clear communication, every time.

Focus	Duration	What You'll Need
Communication, Energizer	Depends on group size (and how much fun you're having!)	A list of relevant phrases/words to your industry and company

Good old-fashioned charades can teach your team a lot about the importance of both verbal communication and body language. Also, it's just plain fun, and as a result sure to help your team bond.

Give each individual a word or phrase. Have the first participant stand up and act out their word (without saying anything!)

You can create a list of words or phrases relevant to your company. Otherwise, you could try the following suggestions, some harder than others:

- Email
- Hanging up the phone
- Coffee break
- Telephone
- Late for work
- Put yourself in their shoes
- Cold transfer
- Live chat
- Communication
- Success

While the traditional game has the person who guesses the word/phrase correctly perform next, it's often easier and more efficient to assign turns no matter who guesses correctly.

Customer Service Coat of Arms

DEBRIEF

Although we are one team striving towards great customer service outcomes, your own contributions and visions of great service are important too. Our different passions and specialisms are what works together to make great teamwork, so it's really important to stay connected to those things that you're passionate about, and which make you feel like you've done a great job at the end of each day.

Focus	Duration	What You'll Need
Teamwork, Best Practice	30 minutes	Coat of Arms templates (on next page), colored pens and pencils

This is an activity which can be adapted for any particular area of work or customer service.

Give each team member a copy of the template and explain that this is a template for a coat of arms. Coats of Arms were traditionally used symbolically to denote particular aspects of a family's identity that they felt were especially important for others to know.

Explain that for this activity, team members will be drawing their own personal customer service coat of arms. Each quadrant should contain something that represents customer service to them.

Give team members 15 minutes to draw their coat of arms, and 15 minutes for the team to share and explain their representations.

Draw out similarities and differences between each other's drawings.

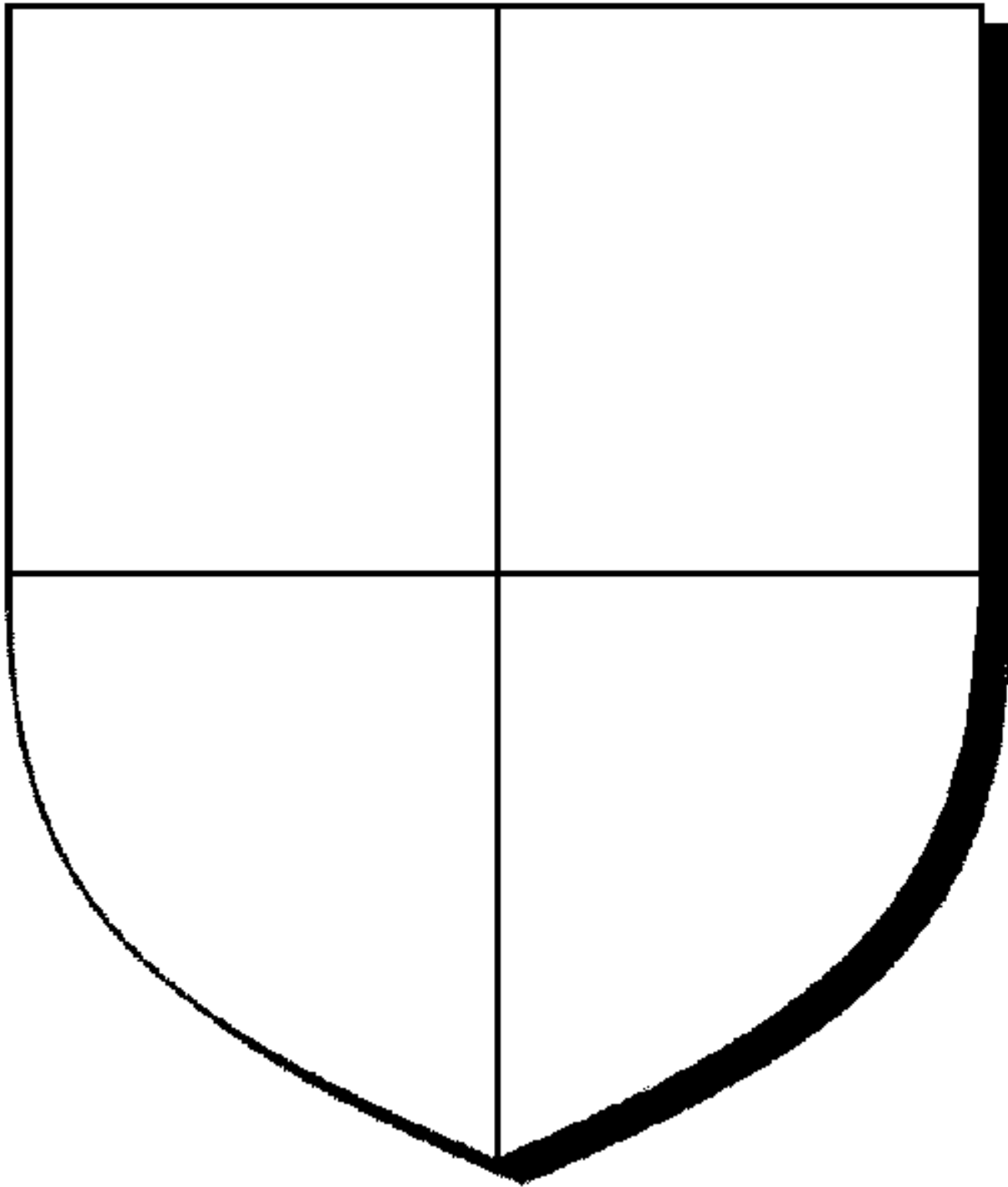
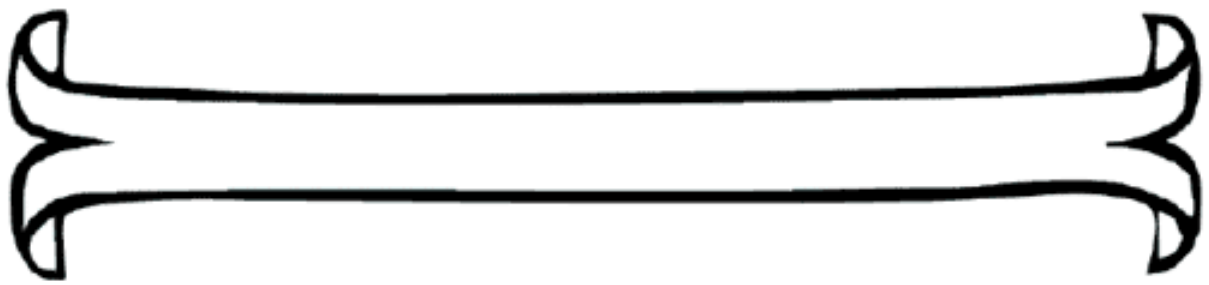

Customer Service Means...

DEBRIEF

Although customer service might mean different things for different people, you can see that there's a lot of common ground between these definitions, even though we've all been using different words. Having a clear vision of what we want to achieve will always make us more focused, working in a joined up way, and stronger as a team.

Focus	Duration	What You'll Need
Best Practice, Customer Service	20-30 minutes	Pen and index cards, a timer, whiteboard or flipchart

This activity is adapted from [The Big Book of Customer Service Training Games](#).

Write the following words and phrases onto index cards: extraordinary, delight, serve, above and beyond, discovering, like family, adding value, positive experience.

Separate individuals into groups of two or three. Hand each group an index card, and ask them to write down, using the word or phrase given, their definition for excellent customer service. Give each group 5-8 minutes to complete the activity.

Then ask a representative from each group to read their statements out loud to the other groups. Guide the discussion to find the common link between all definitions, and create a definition together on a white board.

Customer Service Superheroes

DEBRIEF

Being a customer service superhero isn't easy, and you might not be able to do these things all the time. But for each and every interaction you have today, question yourself and ask 'Is there anything else I can do? What other needs might this customer have?' Doing this will help you deliver service that's truly effective and adds even more value than the customer originally anticipated – moving you ever closer to being their customer service superhero.

Focus	Duration	What You'll Need
Best Practice, Teamwork	20 minutes	Flipchart/whiteboard and different colored pens

This is a fun activity to get your team members thinking about the attributes of great service that are really important to your organization.

Split your team into groups of three or more and ask each group to draw a picture of their customer service superhero on a flip chart or whiteboard. This superhero should embody everything that your customers want. It can be as fun, irreverent and artistic as they like. Ask them also to come up with a name for their superhero.

Once the groups are done, ask each team to introduce their superhero and explain the rationale for certain features.

As the groups describe their pictures, point out particular features you really like. You can either pick a winning team and give them a small prize, or congratulate everyone for their contribution. The finished pictures can be put up in your office to remind everyone what great service looks like!

Drawing Blind

DEBRIEF

Customer service can be quite like this – customers can't necessarily see the whole picture, so it's your job to explain things as clearly as possible. In the same way, if a customer has an issue, they may not be able to explain it clearly to you, so you need to have very good questioning skills to draw out key information and check that it's correct. Think about what questions you used were most effective, and how you could improve your performance in this activity in future – it's very likely that the same skills will transfer to talking to customers in communication situations that aren't face to face.

Focus	Duration	What You'll Need
Communication, Questioning Techniques	20 minutes	Picture printouts (on next pages), pens and paper, surface to draw on (e.g. folder, clipboard)

Split your team into pairs and explain that you will all be thinking about barriers in communication and how to overcome them.

One person from each pair will need to draw, and one person from each pair will need to give instructions. Give your pairs a moment to decide who will be who.

The task to complete will be for the person who is drawing to accurately reproduce a picture which their partner will have. The only catch is, the person drawing will not be able to see the picture – their partner will be giving them instructions on how to draw it giving only details of shapes and lines, and not giving away what the picture actually is (For example, if the picture is of a house, the person giving the instructions cannot say “Draw a door”, they will have to say something like “Draw a rectangle with a small circle halfway up its length and towards the right hand side of the triangle.”)

Give each of the “drawers” blank pens and paper as well as a clipboard or something to lean on. Give each of the “instructors” one of the pictures.

Make sure your team members are seated so that the pairs are facing each other, but the people drawing cannot see any of the other instructor's pictures.

Ask the pairs to begin, and give them five minutes or so to draw the picture.

Once done, ask the pairs to show each other their drawing and the original picture. There will probably be quite a lot of laughter in the room, as the drawings are often very different from the original pictures!

Pose the team a few questions.

- Drawers – how did you find that?
- Instructors – how did you find that?
- In terms of the way you communicated, what worked well?
- What didn't work so well?

If you have time, you can repeat the activity, with the pairs swapping roles and using different pictures. If so, you can ask the following question once done – Was that activity any easier to do, now you have had experience of being in the opposite role?

If you like, you can stick the drawings up on a wall and ask the team to vote on which one was the most accurate representation of the original picture, giving out a prize to the best pair.

Reassemble the group and ask them how this relates to their work. Draw out observations relating to the difficulties of communication when you can't see exactly what the customer is seeing – that communication over the telephone or via live chat can produce these same barriers. You can also probe a little into the questioning and listening techniques used during this activity, and draw parallels to customer communication. What types of questions were most effective? In what ways did you check information given for accuracy?

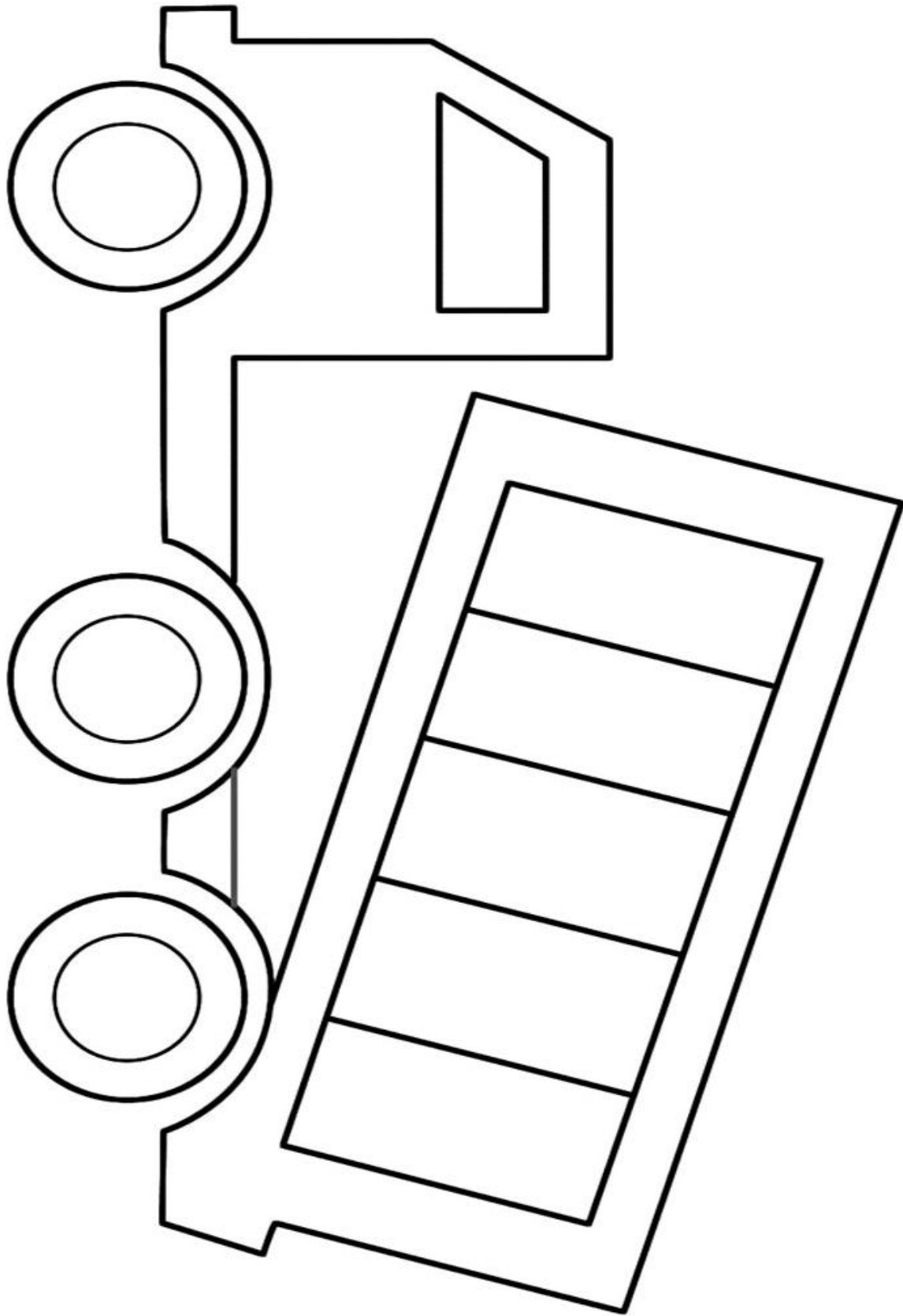

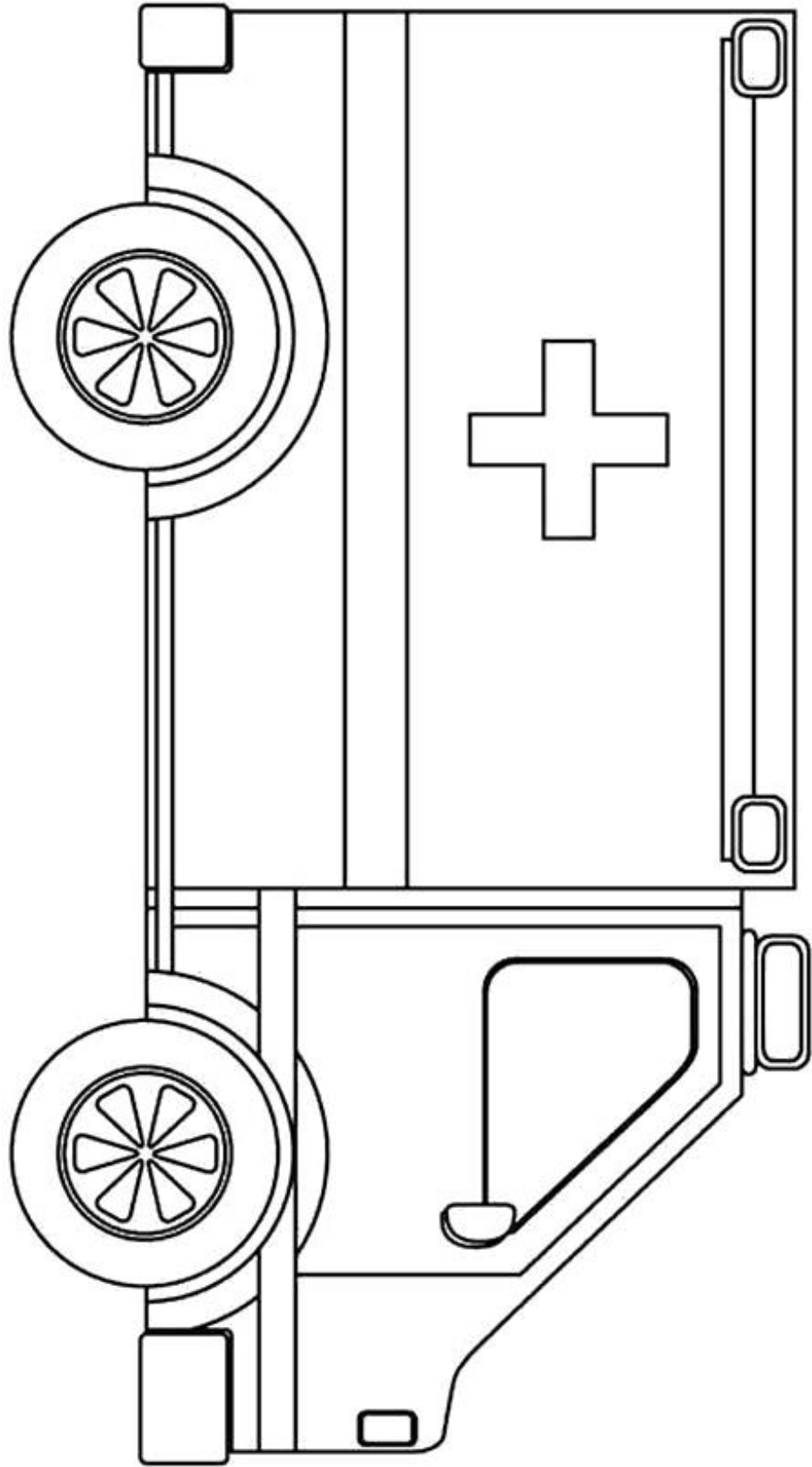

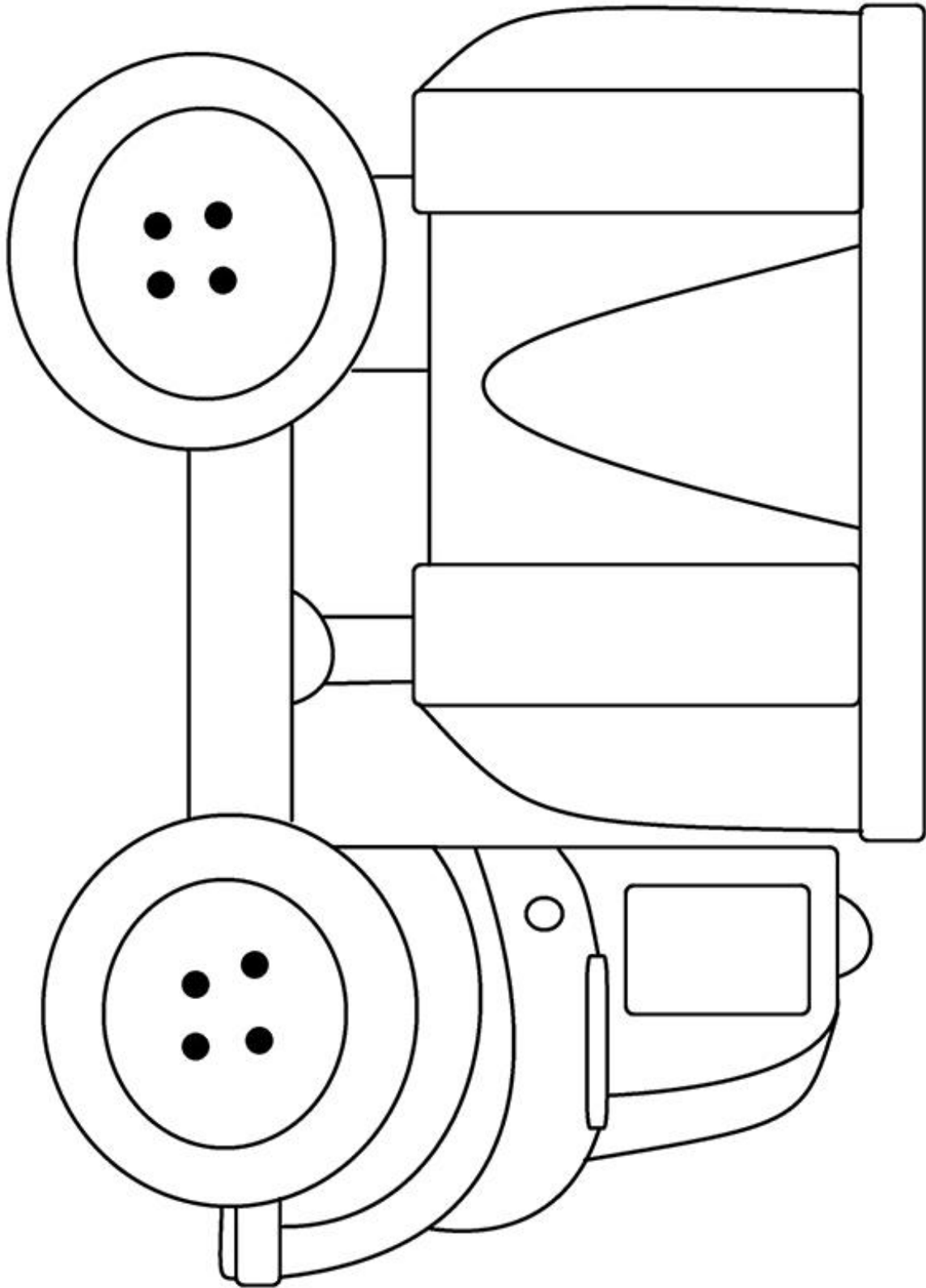

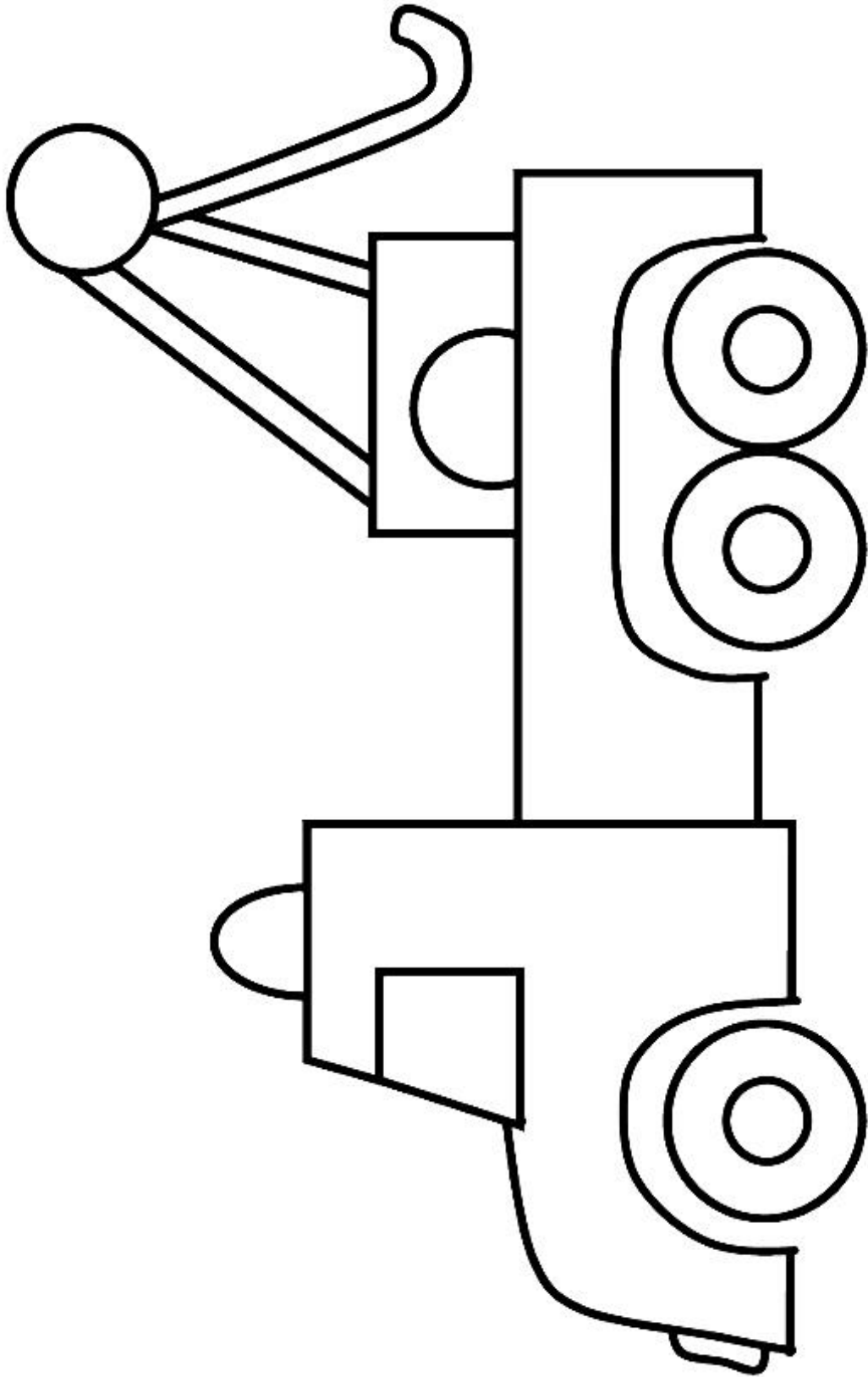

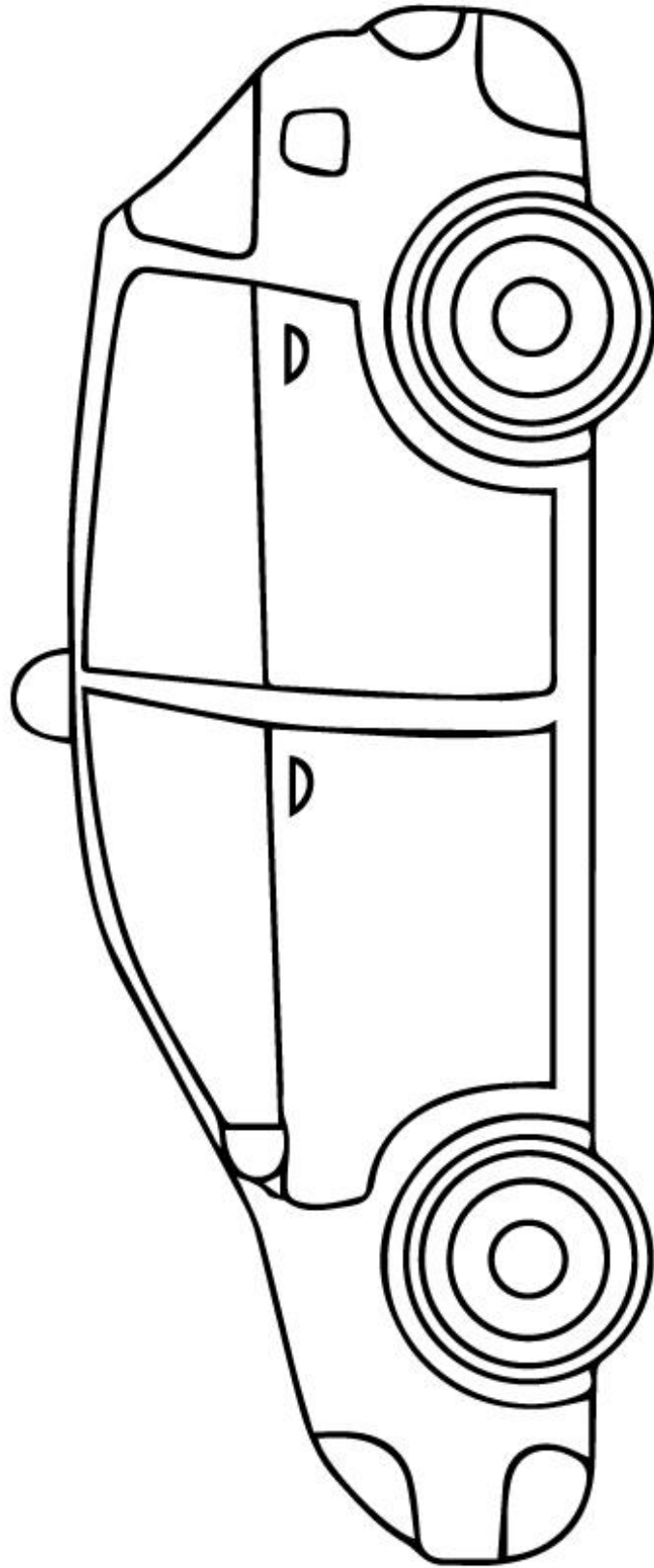

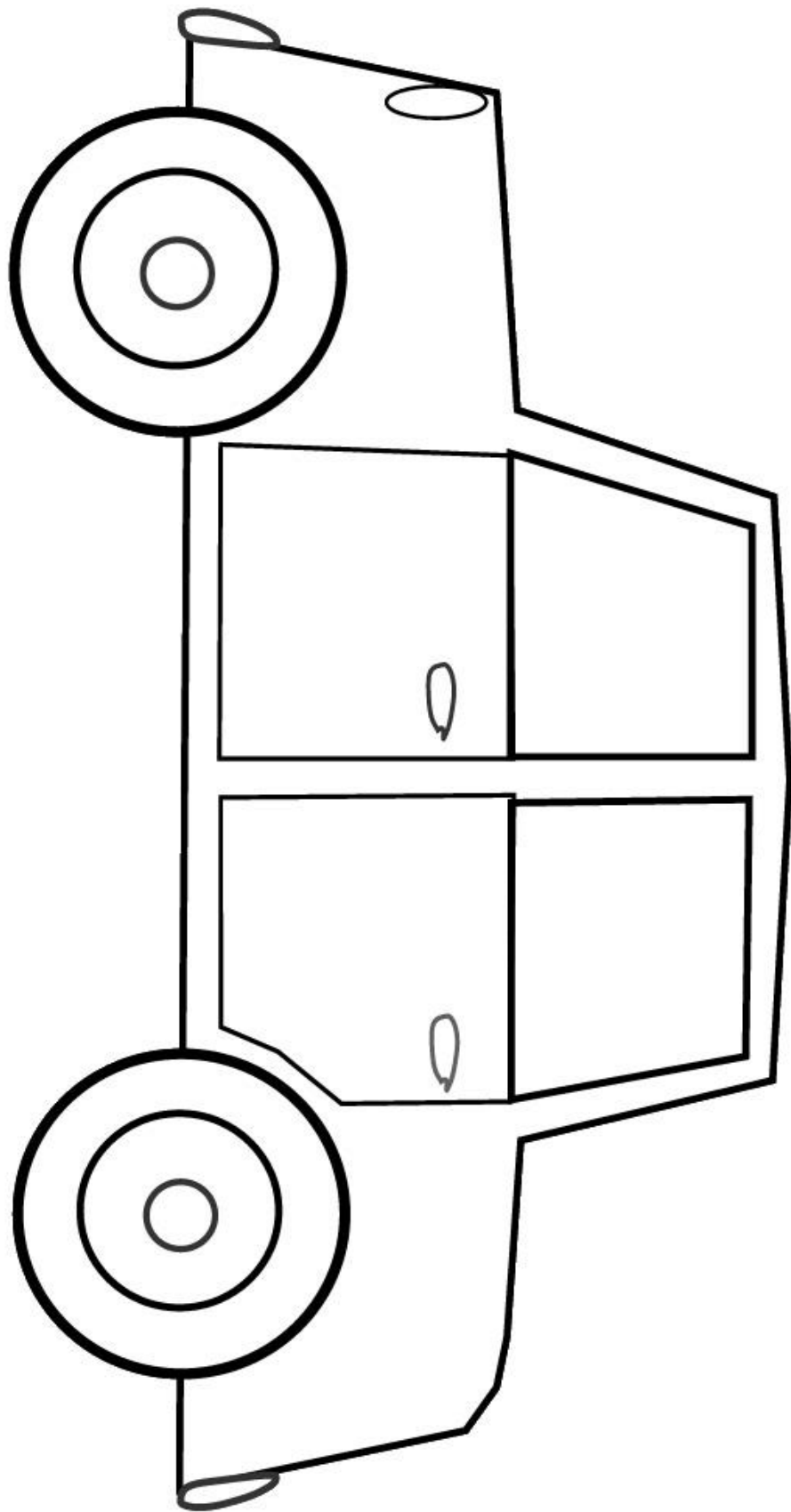

Empathy Bingo

DEBRIEF

Although it can be more difficult to be empathetic when you're not feeling so relaxed, or when you're interacting with strangers, empathy is a skill and you can train it like any other. It's not a personality trait, and it isn't fixed – empathy levels rise and fall depending on the situation. When you talk to your customers in the future, practice stepping outside of your 'empathy comfort zone'. You might be surprised to find that you have the power to train your empathy skills to a truly professional level.

Focus	Duration	What You'll Need
Empathy, Communication	10 minutes at the start and end of a day	Empathy Bingo Card (on next page) and pens

This activity is adapted from the book "[Empathy - Why It Matters, and How to Get It](#)" by Roman Krznaric, and uses many of the empathy statements from our article [30 Empathy Statements and Phrases That Show Customers You Care](#).

At the start of the day, gather your team.

Explain to the team that in order to be more empathetic, one of the first steps is noticing in what contexts empathy is used and tune our 'empathy radar' to understand when it happens best. This allows us to identify the situations it can be used in more effectively.

Ask the team to shout out some of the things we say when we are demonstrating empathy, and note them down on a whiteboard or flipchart.

Give the team the bingo card and point out that it contains a number of different statements you can use to show empathy. Their task for the day is to play bingo with the statements there.

Team members can either listen out for phrases said by others, or mark down things they themselves said, to colleagues or to customers – as long as they were said authentically!

By the end of the day, you should have a winner – give them a small prize if you wish.

Gather your team and ask them to think about the following things:

- When empathetic things were said by yourself or by others, were the speakers relaxed or stressed?
- What kind of mood were they in?
- Were they empathizing with people they knew, or people they didn't know?

It's likely that the team noticed empathy being shown most from people who were relaxed, in a good mood, and who knew each other well. Position to them that the situations it can be most challenging to show empathy in, are situations when we're not feeling very relaxed, or when we're trying to relate to strangers.

Empathy Bingo

If I were in your position, I would feel the same way	You could consider...	So what you're saying is...	I see what you mean	Thank you for remaining so positive
It's my pleasure	Thank you for letting us know	That would frustrate me, too	What would be the best option for	Is there anything else I can help you
I agree with you	I'm so sorry that's happened	I can completely understand	That's great!	I can help you with that
That's absolutely understandable	How do you feel about...?	I can see your point on that	I would come to the same conclusion	Would you like to try...?
You might find xxx helpful	Could you explain...?	You are totally right	Your feedback is really important	I appreciate your patience

Encourage them to talk

Make them feel valued

Put yourself in their shoes

Ask more questions

Think and suggest relevant options

Happy to help

You can brighten their day!

Famous Communicators

DEBRIEF

There are many people in the media who model great communication styles, and others who unfortunately show us exactly what we shouldn't be aiming for! By looking at the specifics of what great communicators do in their words, tone, facial expressions and body language, we can identify and borrow some of these things to improve the way we communicate. Think about what things you can try doing today to make us sound more confident, assured, and reassuring for our customers.

Focus	Duration	What You'll Need
Best Practice, Communication	20 minutes	Flipchart/whiteboard and pens, ability to play YouTube video with sound

Examining the communication styles of others often helps teams identify their communication strengths and weaknesses. This activity encourages your teams to think about what makes great communication and what lessons they can learn from famous communicators.

Ask your team collectively to agree on a famous person who is a great communicator. Once they have identified a person, search for that person on YouTube and play a short clip of video of them talking. Do the same for a person who is not a great communicator. The team should have fun thinking of a famous person who is the opposite of what they are aiming for!

Split the team into two groups and assign one of the communicators to each. Ask each group to write the name of one person at the top of the flipchart/whiteboard and to list the things that they do that make them a good or a bad communicator. (If you have time to fill, you could even ask them to draw a cartoon of that person and fill in ideas around it.)

Give both groups a few minutes to create a list of attributes. If needed, challenge them to drill down into the specifics of what comprised that great communication – for example, writing “They sound confident” is good, but “Their body language and tone is steady and confident” is even better in pinpointing exactly what it is they are doing in the course of communication which makes them sound confident.

Once done, ask each team to run through their points with the other team, and draw out any areas you find especially relevant or interesting.

Football Fun

DEBRIEF

None needed, this game is best done just for fun!

Focus	Duration	What You'll Need
-------	----------	------------------

Energizer	5 minutes	Nothing
-----------	-----------	---------

This is a simple game to get your team energized and moving if they are starting to dip in energy.

Ask the team to stand in a circle, and explain you are going to play an imaginary game of football. Their job is to pass the ball to other team members in different ways.

One way to give the ball to another person is to pass it. Demonstrate a simple passing motion using the side of your foot to move an imaginary ball.

Ask the group to take turns passing the ball while also saying who they're passing it to – for example, they will need to shout out "Passing to Rob." Once a team member has been passed the ball, they will need to pass it on in the same way. Let them try this for a bit to get used to it.

Now, explain that as well as passing, they can also kick the ball. Demonstrate a kicking motion and ask the group to move the ball between each other by either passing or kicking, whatever they choose. They will still need to say what they're doing and who they're sending the ball to, for example, "Kicking to Anna."

Let them try this as well. At this point, they will probably be laughing as they will be mixing up the names of the actions and names of participants while they try to concentrate on the correct motion to make.

Introduce one final element by explaining that there is one extra way they can pass the ball – a header. Do a jump on the spot to mimic heading a ball and explain that this would be, for example, a "Header to Kevin."

Explain that by this stage, the game is getting good and goals will probably be scored soon. Explain that the team will need to watch out for you

celebrating a goal, which will be done by silently raising both hands over your head – at which point the team will need to stop what they’re doing, also raise their hands above their head, and shout “GOAL!” or cheer. Once the goal has been celebrated, they will need to carry on from where they were.

Tell the team to begin, using all of the elements you’ve discussed, and remember to raise your own hands every so often in a goal celebration!

Four Square

DEBRIEF

As you speak to your customers today, think about what options you are offering them. How do you find out what's best for your customer? Just ask them. Don't make them go through lots of effort to get to a comfortable place – instead, really put yourself in their shoes and ask, are the options I'm giving truly the best ones for this customer?

Focus	Duration	What You'll Need
Energizer, Best Practice	5-10 minutes	Masking Tape and a timer

This activity will help participants see the value in a comfortable working environment, as well as the importance of creating a good and comfortable environment for their customers.

Divide the room into four quadrants with the masking tape, and assign a number to each quadrant.

Explain to team members that within each quadrant they are expected to perform the assigned activity for 45 seconds:

- Jumping on one foot repeatedly
- Reciting the alphabet backwards
- Singing nursery rhymes as loudly as possible
- Relaxing

At first you will assign people to their first quadrant to keep the amount in each space even. Then after 20 seconds, shout: "Switch!" Participants are allowed to go to any other square they want, but they must switch, and they must visit each quadrant once.

By the fifth round, you will find that most people are in the fourth quadrant—by far the most comfortable!

Fresh Perspectives

DEBRIEF

Perceptions are really powerful in shaping the way we behave towards, and respond to others. Outward actions reflect inside thoughts more clearly than you might think. When you're disagreeing with someone, take a moment to consider what they need from you and how they might feel about your interaction – you can gain some real insight from this which can help you to change the situation into a more positive, collaborative and productive one.

Focus	Duration	What You'll Need
Empathy, Self-Awareness	30 minutes	Whiteboard or flipchart

This is a great activity for helping team members develop empathy for others and also gain awareness into how they are perceived.

Split your team into pairs. Ask the pairs to share with each other a time they have disagreed with someone, whether it's a recent customer interaction or something personal. Give them five minutes to do this.

Next, explain to your team that they now need to completely remove themselves from the situation and consider it from the other person's perspective. Ask them to consider a few questions (and write them up on a whiteboard or flipchart so they can be seen.)

- How does the other person see you?
- How does the other person feel they get along with you?
- What does the other person need from you?
- What would the other person like to get out of your interactions?

Explain to the group that the person who is listening will need to make sure the conversation stays from the perspective of the other person – it can be very tempting to lapse back into explaining things from your perspective.

Give the pairs ten minutes or so to do this.

Then, ask the pairs to share together any insights they had or things they have learned. Give them five minutes or so to do this.

Ask for any volunteers to share their thoughts.

HEARD Roleplay

DEBRIEF

When a customer is upset or angry, it may not always be our fault, but it is our problem. Using a technique like this is great as it ensures that you're handling all customer complaints effectively and in a consistent way. Although following this might feel a bit clumsy and awkward at first, with repeated practice it will become natural for you to respond to complaints in this way. Give it a try and see how it helps you.

Focus	Duration	What You'll Need
Difficult Customers, Communication	15-20 minutes	Whiteboard or Flipchart

Gather your team and explain that Disney has to handle over 135 million customers in their parks each year, so customer service isn't something they take lightly.

Explain that the technique Disney has developed to train customer service representatives on angry customers is called HEARD:

Hear: Listen to the customer's entire story.

Empathize: Use phrases that convey that you understand how the customer feels.

Apologize: And do so effusively!

Resolve: Fix the issue, and if you don't know how, ask the customer, "How can I set this right?"

Diagnose: Get to the bottom of the issue – that way you can make sure it won't happen again.

Write this on a whiteboard or flipchart while you explain, so the team can clearly see all of the steps. Then ask for a set of volunteers and tell the other participants that they'll act as judges.

Provide the volunteers with a scenario that you may have seen happen in your company—something either common or comical to keep their interest.

Assign one role-player to be the customer service agent, and the other to be the customer. Ask them to move through each of the five steps.

Ask the rest of the team to offer advice or suggestions if the pair gets stuck.

Afterwards, ask the team to discuss how the customer service agent handled each step, and to explain the impacts of what happened.

Let Me Tell You What I Can Do

DEBRIEF

Sometimes, customers will ask us for things we just can't do. It's always best to avoid saying no, and work with your customer to offer alternatives. In this activity you will have come up with some great ideas for meeting your customer's needs without just turning them down and leaving their request unfulfilled. Asking your customer questions to explore why they wanted a certain thing, allows you to offer an alternative that more closely matches their requirements – even if the original request was totally impossible to fulfill!

Focus	Duration	What You'll Need
Communication, Questioning Techniques	15 minutes	Just your team

This activity is adapted from [Business training works](#).

Ask your team to get into pairs. Explain that the object of this activity is to explore how best to offer alternatives.

One member of the pair should ask the other for something they cannot say yes to. It can be as outlandish or silly as they like. For example, "I want a pet elephant".

The team member receiving this request should think of an alternative to offer, without directly saying no. For example, "The local pet shop has a lot of great animals which might fit better in your house. I'd recommend buying a dog. Some of them are quite big and they're a lot easier to clean up after!"

After two rounds, swap the pairs and ask them to repeat the activity. This time, challenge them (if they haven't already) to ask some probing questions of the requester to find out why they want what they have requested, to find a solution which more closely meets their needs.

An example of a good probing question would be "Can you tell me more about why you'd like a pet elephant?" or "Why is it important to you to own an elephant?"

Once the pairs have finished, ask the requesters whether their original request was more closely matched when they were asked a few questions about why they wanted what they did. The team will agree that this allowed them to find better solutions.

Marshmallow Challenge

DEBRIEF

In our teams, you might find that you naturally take a particular role – whether it's more action-focused, coordinating, or planning. It's really important to have a mix of different people in teams with different strengths and preferences, to make sure that we can complete tasks effectively. This activity will have demonstrated some of the ways we can use our natural resourcefulness and communication skills – as even in the direst of customer service scenarios, we're stronger when we work together.

Focus	Duration	What You'll Need
Teamwork, Communication	30-40 minutes	String, 30 pieces of dry pasta (per group), one marshmallow (per group), one meter of tape (per group), one piece of string (per group), timer or stopwatch

This design challenge was made famous by [Peter Skillman](#) at a conference in 2007, and even has a [Ted Talk](#) discussing its benefits.

This activity works brilliantly in conjunction with [Belbin's team roles](#), to illustrate the different roles in action.

To start, divide people into groups of 3 to 6, and give them the supplies listed above. Then give them 18 minutes to build the tallest, free-standing tower.

Once done, ask the groups some questions to draw out how they worked together to complete the activity:

- Was there much planning done, and what did that look like?
- Who took the lead?
- Who contributed ideas?
- Did anyone have any ideas they wished they'd contributed but didn't? Why is that?
- Was communication effective?
- What parallels can we draw to our workplace interactions?

Don't forget to take pictures of the resulting towers—you'll be inspired by the creativity!

Mission Possible

DEBRIEF

Customer service means different things to different people. But one thing that unites all of our definitions is that they all cover off the ways that we try to be at our best when interacting with our customers. Think about the ways that you can develop and live by your personal and team definitions as you interact with your customers today.

Focus	Duration	What You'll Need
Best Practice, Teamwork	20-30 minutes	Print outs of your company's mission statement (or digital copies), and pieces of paper, pens (or access to a shared document)

This activity is adapted from [The Big Book of Customer Service Training Games](#).

Divide your team into smaller groups based off of different departments, or people who share similar duties or shifts.

Discuss the company mission statement as a whole, and then ask each group to create a collective mission statement for their team.

Have a spokesperson from each group present their mission statement after fifteen minutes.

Encourage the other groups to share their thoughts as the groups take turns to share their mission statements.

Once finished, pose some questions for discussion:

- Which definitions do they like best, and why?
- Are all the mission statements true, all of the time?
- Why isn't there one common definition?

Then, with the extra time, encourage individuals to create their own personal mission statement with the company, and suggest they keep it somewhere visible in their office or on a sticky note attached to their computer.

Movie Madness

Debrief isn't strictly necessary as this activity is great when done just for fun. However, if you would like to develop themes relating to teamwork, you can draw out relevant things you noticed about the way the team organized themselves and communicated in the timescale given. If necessary, ask some questions to prompt conversation:

- *How easy was that activity?*
- *Was communication effective or not, and why?*
- *Were there any tactics that people tried that worked well?*
- *Did you all work together well as a team?*

Focus	Duration	What You'll Need
Energizer, Communication	5 minutes	A clock or timer

This energizer works very well with a large team, although you can run it with a smaller group by imposing time restrictions.

Ask your team to think of their favorite movie.

Then, ask them to line up in alphabetical order, using the first letter of their favorite movie. Make sure you tell them which end of the line is A, and which end is Z.

Impose a challenging timescale for this. For groups of less than ten, thirty seconds is a good time. For groups bigger than this, a minute is an appropriate time.

Once the team is finished, ask them to shout out their favorite movie, starting with the "A" end of the line, to see if they got it right.

Pipe Cleaner Sculpture

Debrief is not needed for such a quick and fun task, however you could link this to the importance of teamwork and ask the group what might have happened if everyone had put their pipe cleaners together to create a huge sculpture.

Focus	Duration	What You'll Need
Energizer, Teamwork	15 minutes	Pipe cleaners

Give each team member three pipe cleaners and explain that they will have ten minutes to create a sculpture. The best sculpture will win a prize.

Ask them to start and let them create!

Once finished, reassemble the team and ask them to vote on which one is best – however give special consideration to anyone who banded together as a group to create a bigger and better sculpture.

Protectors and Enemies

DEBRIEF

None needed, as this activity works best when it's done as an energizer just for fun – although you could potentially draw some parallels to the difficulties that occur when we don't effectively communicate what we need – we all can start running around like headless chickens!

Focus	Duration	What You'll Need
-------	----------	------------------

Energizer	5 minutes	Nothing
-----------	-----------	---------

This is a fun game to play when you have your team in a reasonably large room and you want something to energize them after a long training session or when returning from lunch.

Tell your team members to silently select one person in the room who will be their protector. Give them a moment to do this.

Then, ask your team members to silently select one person in the room who will be their mortal enemy. Remind them that this game is just for fun, it doesn't mean that the chosen person is actually their enemy!

Each person's job is to try to keep their protector physically between them and their enemy at all times.

Ask the team to start and watch the fun begin as team members start running around the room!

Stop the game whenever you wish and ask a few people if they succeeded in keeping their protector between them and their enemy. You can also ask who people's protectors and enemies were.

Questions Only

DEBRIEF

Conversations with lots of questions in them can be difficult, and sometimes it can take some skill to gather information without it sounding like a barrage of questions or an interrogation. Varying your tone, pitch, and positioning the need to ask a few questions can help to make your conversation sound more natural.

Focus	Duration	What You'll Need
Questioning Techniques, Energizer	10-15 minutes	A timer, optional screen/sound for showing video

This activity comes from the classic TV show, “Whose Line Is It Anyway?” It serves as a fun ice-breaker, but also encourages team members to actively think about questions they have been asked by customers, and how best to respond to these.

To play, ask for several sets of two volunteers.

Then invite a set to the front, prompting one of the two to ask a question a customer has asked him or her before.

Then the other volunteer must respond with a question—the entire conversation should be composed of questions for a minute.

Ask the team a few questions:

- In what situations are questions most effective?
- What other ways can we gather information from our customers?
- What specifically would have made these conversations flow more easily?
- Does it sometimes feel difficult to ask customers lots of questions? In what situations?
- How can we make asking questions easier?

If you like, you can end the activity by showing a [clip](#) of this game from Whose Line Is It Anyway, to illustrate the different ways that questions can work (This clip is PG-rated – if your organization is more conservative, you may want to omit this step.)

DEBRIEF

Imagine what would happen if you turned up for a trip to a snowy mountain only with beach clothes? The trip would be a disaster, and you'd need to abandon it. The same goes for teamwork – we all need to know where we're going, and prepare for the journey, in order to reach the destination together. In our team, we need to work together and be clear on our goals. Take the time today to consider what your goals are, and how they match with the rest of the team, to make sure you don't get caught out along the way.

Road Trip

Focus	Duration	What You'll Need
Teamwork, Communication	5-10 minutes	Paper and pens

This activity is adapted from [10 Customer Service Activities To Supercharge Your Team](#).

Have groups of two to four get together and decide collectively: What are the three best items to bring on a trip? Give them a short amount of time and then ask them to share their answers.

As they share their answers, quiz them on why they needed that particular thing and what type of destination it would be appropriate for. If a person says clothes, for example, ask them if the clothes are for warm or cold weather. If someone says money, ask if cash or card is better where they are heading.

In the second round, give each group a slip of paper with a destination, and ask them to repeat the activity.

DEBRIEF

Closed questions are not a good way to gather information. You will have needed to use great communication and creativity to get round this barrier and find your matching person. Most of us tend to think we use a good selection of open questions to get to the heart of the issue, but in reality it can be more tricky to find a truly effective question that gives you all the information you need right away. Really effective, probing questions that start with 'Can you tell me...' or 'Can you explain...' give your customer a chance to tell you more about what's important to them, allowing you to craft even better solutions. If this isn't something you do already, try it today and see how it improves your interactions.

Salt and Pepper

Focus	Duration	What You'll Need
Communication, Questioning Techniques	10-20 minutes	Paper, pen, tape

This activity is adapted from [Refresh Leadership](#).

Closed questions can work as a huge barrier to effective communication. In this activity, your team will see the impact of closed questions on communication, and explore how they can use more open questions to gather better information and reach quicker conclusions.

Prepare the activity by writing pairs of things, each on one sheet of paper. Examples you can use could include: Salt and Pepper, Peanut Butter and Jam, Batman and Robin, Fish and Chips, Mom and Pop, Black and White, Knife and Fork, Bread and Butter, Bow and Arrow, Cat and Mouse. Write up enough for each person in your team.

If you have an odd number of team members, make sure you take part as well.

Mix up the pieces of paper and prepare some strips of tape.

Gather your team and explain that each team member will be assigned one item out of a pair – for example, if the pair is Salt and Pepper, they will have just Salt. This is written on a piece of paper which will be taped to their back. Their job is to find the person with their matching item, but they are only allowed to ask closed questions (questions with a yes/no answer) to do this.

Ask your team members to stand in a line, and tape the pieces of paper to their backs.

When you say go, let the team members walk around trying to find their matching pair. This should be a fairly tricky activity! When you see a pair succeed in finding and identifying each other, ask them to sit down.

If the activity is dragging on and you need to finish it, announce to the team that they can now use open questions. The game should then finish very quickly!

Ask your team to discuss how difficult this felt, and what strategies could have helped. They should be able to recognize that different questions are useful in different situations.

Say My Name

DEBRIEF

There are lots of different levels of listening, and to truly listen deeply is something that we can often find difficult, especially with distractions around us. Think about what tips or techniques you can use in your communications to make your listening skills top notch.

Focus	Duration	What You'll Need
Teamwork, Listening Skills	10-15 minutes	Worksheets and a timer

This activity requires at least six people, and works best with a large group of 12. Have two groups of three (or thereabouts, depending on numbers) line up to face each other. Explain that they will have two minutes with the person opposite them to both ask and answer some questions, at which point they will move and ask another person the same questions.

- What's your name?
- What's a hobby of yours?
- What was your first pet's name?

Tell the team to start, and make sure at the end of each two minute slot, you move one line along so they are speaking to someone different (regardless of whether all questions have been asked and answered!) After three rounds, stop, and ask them to write down all of the answers they have collected. Then, ask them to share their answers. The team will probably struggle with this!

Repeat the activity for another round, swapping the groups so that they are speaking to somebody new. The activity may be difficult, but with each round your team members will improve as they realize the importance of listening when providing quality customer service.

Once finished, pose the group a few questions:

- What made this activity difficult?
- Did it get easier as you went through the rounds? Why is this?
- Did you use any techniques to help you?
- What can we learn from this to apply to our customer interactions?

Show and Tell

DEBRIEF

We're stronger when we share our experiences with others, and it's important to talk about and learn from situations that are challenging, as much as it's important to celebrate our successes. Never be afraid to talk about difficult situations – part of what's great about being part of a team is having the openness and trust to share and learn from each other.

Focus	Duration	What You'll Need
Difficult Customers, Best Practice	20-40 minutes	Sheets of paper and pens (or a prompt in a document for virtual teams)

Give each participant a piece of paper and five minutes to recreate a difficult customer service experience they had and to share how they resolved it.

This could be due to a number of factors, whether it be a difficult customer, internal error, or multitasking strains.

Encourage participants to think creatively. Then have the team break up into smaller groups of 3 to 5.

Each person should share with their group the situation and how they handled it. Then other members in the group should be encouraged to offer a compliment on what the speaker did well in the situation, as well as offer suggestions for the future.

Step into the Difficult Customer's Shoes

DEBRIEF

Customers are not usually deliberately rude, demanding or vague. Usually they will have had a bad experience in the past that has caused them to be this way, or they could just be having a bad day. It's important to remember that when you're confronted by one of these customers, there will have been a chain of events for each and every one of them which caused them to act the way they are acting. Knowing this will help you remain objective and solution-focused when these customers come to you for help.

Focus	Duration	What You'll Need
Empathy, Difficult Customers	10-20 minutes	Sheets of paper and pens

Break your team up into smaller groups of 3 or 4. Ask each group to spend five minutes coming up with a rude, demanding, or vague statement a customer could say based off of their own experiences, and write this on a piece of paper. Then have someone in the team fold the paper over and hand it to the team to their left.

For the second round, give teams 5-10 minutes to develop both a backstory and response to the fictitious customer.

Have groups share the message, the created backstory, and their appropriate customer service response.

Stuck in Quicksand

DEBRIEF

You can use this video to help you deliver a creative and powerful debrief: [Brené Brown on Empathy](#)

Wrap up the session by asking your team to consider the ways they try to show empathy. Are their methods truly empathetic? Is sympathy easier for a lot of us? Challenge them to try some different things in their communications to show they are really putting themselves in their customer's shoes.

Focus	Duration	What You'll Need
Empathy, Communication	20 minutes	Quicksand diagram / Whiteboard or Flipchart, screen for video

Sometimes, when we are trying to be empathetic we can end up saying the right things but not actually helping as we are not fully considering another person's position from their own perspective. This exercise is useful to help your team identify what a truly empathetic response looks and feels like.

Gather your team and explain that for any given situation another person is experiencing, we can respond to them with empathy, sympathy, or apathy.

Show them the following diagram, or if you like, draw it up on a whiteboard or flipchart.

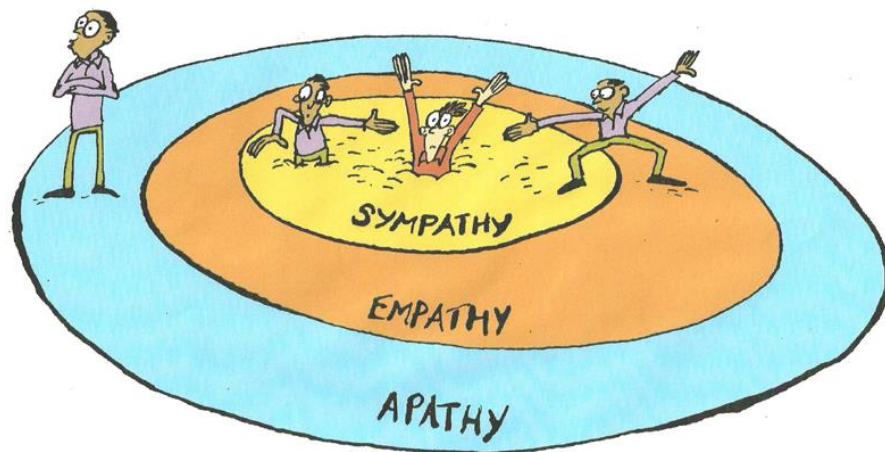

Explain to the team: Imagine that you come across a person stuck in quicksand.

Apathy in this situation would be standing back and not caring, leaving the person stuck.

Sympathy in this situation is a response that acknowledges the other person's situation, but doesn't consider it from their point of view. It doesn't help the situation, or even makes it worse. A sympathetic response to the quicksand situation would be to tell the other person that you'll help but then leap heroically into the quicksand, without thinking that you might also get stuck.

An empathetic response would be to relate to the person's situation and think deeply about what could be helpful for them, if you were in their position. For the person stuck in the quicksand, you might want to think about carefully pulling them out while being aware of your own safety, or calling 911 and staying with the person until you are sure they are safe.

Split the group into pairs and ask them to discuss a customer situation where empathy might be required, what the empathetic, sympathetic and apathetic responses to this might be, and what the impacts of those are. Give them a few minutes to do this.

Bring the group back together and ask them to share their ideas.

Telephone

DEBRIEF

For our customers, even small breakdowns in communication can make a huge difference in getting what they need. As you pass information to other people, think about the ways you can make sure you are heard and hearing correctly. Using questions to check your understanding, and choosing the right method of communication, are two things you can do to make sure your message isn't being lost or misunderstood.

Focus	Duration	What You'll Need
Communication, Listening Skills	10-15 minutes	Smiling participants

Telephone is a familiar game for many, as it teaches the importance of direct communication.

To start, you can break the team into smaller groups (but try not to make the group smaller than 10).

Have each group sit or stand side by side in a line. Then whisper a sentence in the first participant's ear, quietly so that nobody else can hear it.

Suggested sentences are:

- Twelve tiny mice hid from the hungry ginger cats in the apartment on 19 Abbeyvale Avenue
- Bobby boasted to Barry about his brilliant red and white stripy woolen bobble hat
- Six happy kids and two spotty dogs rode the number eight bus on a sunny fall morning
- The vase was full of thorny pink roses and three bright blue tulips with foliage to finish
- Monty the professional potter crafted a terracotta teapot for old Mrs Andrew's earl grey

You can use your own sentence, but remember, it should be fairly easy to misinterpret.

That person will whisper it to the next person and so on. They cannot repeat it if they have misheard it. The last person in the line should say out loud what they have just heard – and you should say what the message originally was.

Count on lots of laughing, as usually the last message is so radically different than the first that people can't help but chuckle!

Gather the team. Ask them a few questions:

- If we were to communicate like this all the time, what would the impact be on our customers?
- What tools do we have around us to stop communication breaking down?
- Do we always use these tools effectively?

DEBRIEF

In this story, we all tend to concentrate on the numbers and the detail, thinking that this is the information that's really important. Sometimes when we are talking to customers, we do the same. It's easy to make assumptions about what you think your customer needs if you've dealt with lots of similar-sounding queries before, or you're not truly focused on what they're saying. Listening actively and asking the right questions to get to the root of their issue will allow you to fully understand their needs, without being blinded by assumptions or unnecessary detail.

The Bus Driver

Focus	Duration	What You'll Need
Communication, Listening Skills	5 minutes	Just your team

This is a great activity to demonstrate the importance of active listening and not making assumptions.

Tell your team you are going to tell them a story. They will need to listen carefully and they should not take any notes. Once you have finished telling the story, you will ask them a question about what they have just heard. If anyone knows the answer to the question, ask them to keep it to themselves until asked to share.

“You are the bus driver on the number 10 bus. At the first stop, 29 people get on. On the second stop, 6 of those 29 people get off, and at the same time, 10 new passengers arrive. At the third stop, 8 passengers get off. The bus is running a little early, so during 3 minutes wait at the stop, 14 people and a dog get on. At the fourth stop, 12 passengers get off, and 2 passengers get on. At the fifth stop, everyone gets off.

How old is the bus driver?”

Ask anyone who knows the answer to put their hands up but not say the answer. Most people in the team who do not know the answer will probably look quite puzzled and some might say that you hadn't given them that information to begin with!

Finally, ask anyone in the team who knows the answer to share it. If nobody knows the answer, share it with them: the very few first words spoken were “You are the bus driver” so the bus driver is as old as you are.

DEBRIEF 1/2

For a team
experiencing change:

Change is a difficult thing for a lot of people to accept. We all tend to like easy, clear instructions, and routine. During times of change, it's not always possible for changes to happen on our terms – they may happen too quickly, or too frequently for our comfort. It can take a lot of courage to accept new ways of being, and stop holding on to what was. Remember that progress isn't possible without change, and by being open to new things, we open up opportunities for even better ways to work and live.

The Change Challenge

Focus	Duration	What You'll Need
Communication, Teamwork	20 minutes	Only your team!

This game is great for a team which is currently going through a lot of change, or you can adapt the debrief to talk about the impact of change on customers.

Ask your team to get into pairs and explain they will be taking part in an experiment about change.

Ask one person in each pair to study their partner closely. Then, tell the partner that they will need to change three things about their appearance. Give them a moment to think what they might change. Once ready, ask the observer in the pair to turn around so they cannot see their partner, and ask the partner to make the changes. Give them thirty seconds to do this.

Once changes have been made, ask the observer to guess what changed.

Ask partners to switch roles and repeat the experiment again.

Repeat the activity as many times as is needed, upping the difficulty as you go. Increase the changes to five. You could even reduce the time to make changes from 30 to 20 seconds or even less.

The changes will get more and more outlandish as the activity repeats – expect to see people removing shoes, changing their hairstyles, or even wearing coats backwards!

When participants start to protest about the amount of changes, stop and move to discussion.

Good questions to ask the team are:

DEBRIEF 2/2

For helping customers accept change:

Our customers might not always see things the way we do. They might not have anticipated a change, or understand why it's happening. And few people tend to like change – it can bring uncertainty into what were stable and expected ways of being. Your job then, is to ask probing questions to allow your customer to explain their thoughts, then give your customer the right information to allow them to understand the reasoning and benefit behind a change. By doing this, you transform them from a bystander on the sidelines watching things happening to them – to a person who is an informed partner in the change process.

- How did that activity feel? Why?
- Why don't some people like change?
- What could have been done differently to help make the changes in this activity easier to handle?

The Curse of Knowledge

DEBRIEF

It's sometimes very difficult to convey information you know well to someone who doesn't have access to that information in the rich way that you do. And it's difficult for you to imagine what it is like for the person who hears just taps, rather than a song. This is called the Curse of Knowledge. Once we know something well, it's difficult for us to imagine what it's like to not know that thing well, and it becomes difficult to relate to others who are not in our position. To stop this, think carefully about the way you explain things. Are you using jargon? Are you taking things step by step? Really analyzing the way you explain things can help you gain control of your communication and stop the Curse of Knowledge in its tracks.

Focus	Duration	What You'll Need
Communication, Listening Skills	5 minutes	Flipchart/whiteboard and different colored pens

This activity is adapted from a [psychological experiment](#) which highlights the importance of clear communication.

Divide the team into pairs. One of the pair should be a “tapper”, the other, a “listener”. The tapper should think of a well-known song, but not tell anyone what it is. They then need to tap out the rhythm of the song (on a table or similar) to their listener, who will try to guess what it is.

Congratulate any listeners who succeeded, and for any listeners who did not get the song, ask the tapper to reveal what it was. The pairs should then swap roles and repeat.

Explain to the team that when this experiment was originally ran, the tappers were asked beforehand to guess the chances that their listener would know the song – and around 50% said they thought their listener would succeed. In reality, the odds were closer to 2.5%.

Ask the team why they think this is. The team should be able to pinpoint that when you can hear the song in your head, you have a clearer “picture” of it than someone without that knowledge.

Ask the team how this relates to their work. They should be able to link this the difficulties of communication when you have expert knowledge of your product and service while your customer does not.

The Dress

DEBRIEF

If something we all view as being universal between us – like our ability to perceive color – is actually not universal at all, this has big ramifications for our interactions. Part of being empathetic is the ability to bridge differences in perception, even if another person’s point of view is radically different to yours. Today, as you speak to your customers, think about the ways that you can relate to, rather than isolate others despite differing opinions. Understanding that others have a right to see things differently can make all the difference in helping people feel respected, listened to and understood.

Focus	Duration	What You’ll Need
Empathy, Self-Awareness	15 minutes	Picture of The Dress (next page)

This is a powerful activity designed to show us that even things that we consider unchangeable in the way they are perceived – like color – can be seen totally differently by different people.

Show your team the picture of “The Dress” and ask them what color it is – is it blue and black or white and gold?

The picture should promote some good natured argument! Let your team reason with each other for a little while. You will find that the group is split, or that some group members are even able to see it both ways. For those who have not seen this picture before, explain that this picture emerged on the internet in 2015 and is still being investigated by scientists because of its ability to show differences in color perception between people.

Now, pose some questions to the group:

- How did you feel about those who saw the dress the same way as you?
- How did you feel about those who saw the dress differently?
- Point out that when this phenomenon occurred, people even put themselves into “Teams” on social media – Team Blue/Black and Team White/Gold. What are the implications of this?
- Can you think a situation in real life when someone saw a situation differently to you? Were you likely to think they were outright wrong? Is it possible that you were wrong, or neither of you were wrong?



The Egg Drop

DEBRIEF

None needed, due to the duration of this activity. However, in the final closing session, you will want to question your team to find out what they learned from this activity and how it can be applied to the workplace, as well as drawing out insights they have relating to teamwork, creative thinking and collaboration.

Focus	Duration	What You'll Need
Teamwork, Collaboration	One Week	Eggs and miscellaneous packing materials and office supplies

This classic science class project isn't just for teenagers—it's also an activity that can help adults think outside of the box and connect with their deeper problem-solving skills and abilities.

Have your team split into smaller groups by randomly selecting a name from a hat.

The idea here is to face challenges with co-workers they might not traditionally work with, just like how you can't pick what customers you're dealing with or what problems you may face.

Now present each group with an egg and encourage them to use whatever supplies exist around the office to create a casing/contraption that can survive a drop from the top of the building, and to convene with their groups over lunch.

At the end of the week have teams drop their eggs from the top of a building to see which eggs survive and which go splat!

The Stranger Challenge

DEBRIEF

None needed, as this activity works best if revisited with participants over a number of days in an informal way – asking them who succeeded, who failed, why, what circumstances led to which actions, and what from this we can apply to the workplace. It’s also important to link back to the reason why you’re doing this activity – to build confidence in communication, get used to pushing the boundaries of your comfort zone, and understand how to weigh up what risks are worth taking.

Focus	Duration	What You’ll Need
Teamwork, Communication	One Week	Smiling participants

[AppSumo](#) has developed a great challenge to get people out of their comfort zone and making connections, which is important for customer service agents who need to be a little more assertive than shy.

This is a great challenge for virtual teams as well, as it doesn’t require an immediate presence and can be done on individual time.

All you have to do is direct workers to [this website](#) and have them follow the instructions.

The Stranger Challenge requires that workers print out the “I Don’t Know This Person” sign, and find a stranger who agrees to pose for the photo with them, effectively pushing them out of the bounds of introverted behavior.

Then challengers can upload their photo onto the site to be featured in the gallery!

Thoughts, Feelings, Behavior

DEBRIEF

Self-awareness is one of the building blocks of empathy. By being able to understand the links between the thoughts you have, the way you feel, your behavior and its impacts on a situation, you begin to look at yourself objectively and give yourself the power to break the cycle. Understanding the way these things are connected in yourself also helps you to relate to the varied reasons why a person might be behaving negatively, and help them find solutions to change their behavior, challenge their thoughts and ease their feelings.

Focus	Duration	What You'll Need
Self-Awareness, Empathy	20 minutes	Whiteboard or flipchart

This is an exercise adapted from [cognitive behavioral therapy](#) techniques, which are traditionally used to help people identify and change “faulty” thinking patterns. It can be very useful for helping a team become more aware of the impact of their thoughts, feelings and behavior on themselves and their customers.

Split your team into pairs and ask them to discuss the last time they experienced feeling angry, overwhelmed, upset, or a similar emotion. Give them 5 minutes to share stories.

Draw up the thoughts / feelings / behavior cycle on a whiteboard or flipchart and explain that the three influence each other. The cycle can continue or get worse if none of these three things change.

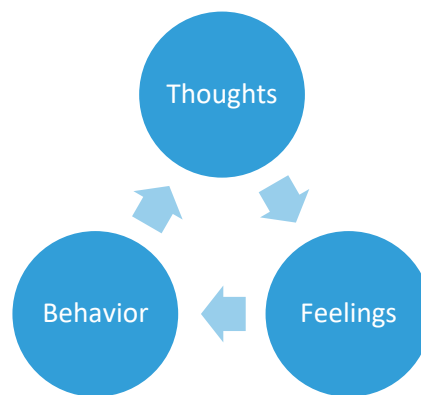

Give an example: Imagine that you need to give a presentation to a group of colleagues. If this makes you feel quite nervous, this could feed thoughts

that you will mess up the presentation, which on the day will make you appear anxious and therefore more likely to fail – which then sets a precedent for you to feel even more anxious about presenting in the future. On the other hand, if you feel like this is a welcome challenge, you will probably be thinking that this is a welcome challenge and on the day, be well prepared and ready to dazzle your colleagues, which will give you confidence if you encounter this situation again.

Ask the team, in their pairs, how the situation they identified before impacted their thoughts and behavior. Ask them also to consider how this would have been perceived by others around them. Give them a few minutes to discuss this.

Bring the team back together and ask them to share some of their observations.

Pose a question to the group:

- How do you think this cycle works for customers who are angry? (The group will probably be able to identify that feelings of upset and thoughts around how difficult their situation could be to resolve could feed a more negative reaction. They might also be able to point out that customers who have had bad customer service experiences in the past might be more likely to react badly to a problem, than those who have overall had positive past experiences.)
- Ask the team which area of the cycle is easiest to change, in order to break out of the cycle? Take some guesses. Then, position to them that research has shown that behavior is the easiest area to change – almost a “Fake it ‘till you make it” approach. Practicing alternative behaviors when you are feeling negative can be the easiest or quickest way to change your thoughts and feelings.

In the example we gave before, if you’re worried about presenting but you choose to “face the fear and do it anyway”, you might concentrate on taking opportunities to practice your presentation ahead of time, even if you don’t like the thought of it initially. This would boost your confidence and go a

long way towards helping you think more positively and feel better about the presentation.

DEBRIEF

None needed, as this activity works best when it's done just for fun!

Touch Something Green

Focus	Duration	What You'll Need
Energizer	5 minutes	Nothing

This is a simple but fun game to get people moving and awake.

Tell your team members that in a moment, you will ask them to touch something in the room that is green. The last person who manages to do this, is out of the game.

Tell them to start, and watch for whoever finds something green last!

The person who is out then has to make a new suggestion for team members to find and touch. This time, team members should start moving as soon as they hear the item they have to touch.

The activity should repeat until you are left with a winner. Give them a prize if you wish.

True, True, False

DEBRIEF

None needed, this activity works best when it's just for fun.

Focus	Duration	What You'll Need
-------	----------	------------------

Teamwork, Energizer	20-40 minutes	Smiling participants
---------------------	---------------	----------------------

Keep groups no smaller than 10 and have the group seated in a circle.

Have each person state two truths about themselves and one lie. For example, you might say that you had a burger for lunch (true), have two siblings (false), and like to play hockey (true).

Then have the next person in the circle decide which statements were true and which statement was false.

After the second individual guesses, the first person will reveal the lie to the group.

This is especially fun for new teams, and can be exercised over a group chat or forum (in this case, just set the order of respondents beforehand by assigning each person a number).

Unique Perspectives

DEBRIEF

All of you are unique individuals, with different cultures and perspectives. That's why we've hired you – can you imagine how monotonous and difficult work could be, if we all came from the same places with the same backgrounds? However, despite our differences, we can all find common ground, even with those who might seem very different to us. Remember this when you're talking to your customers today – despite our differences on the outside, we're often all pretty similar on the inside.

Focus	Duration	What You'll Need
Teamwork, Self-Awareness	10 minutes	Flipchart/whiteboard and pens

Use this to help a team to learn more about each other. This is also a great activity for discussing similarities and differences between team members and emphasizing the importance of diversity.

On a whiteboard or flip chart, draw intersecting circles – as many circles as there are team members. If you have more than five team members, try to split them up into smaller groups – between three and five is a good number. Make sure there is a section in the middle where all the circles intersect, as well as areas where the circles next to each other overlap.

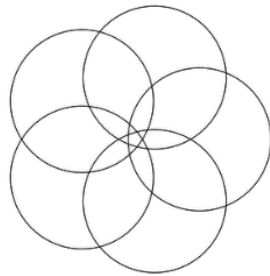

Ask each team member to write one thing that is unique about them inside their circle. To make this harder, you can suggest they are not allowed to use physical attributes, such as hair color, height etc.

Then, ask each team member to talk to the person whose circle intersects theirs, to find one thing that they both have in common. Write these in the spaces where each of the two circles intersect.

Finally, for the area in the middle where all the circles intersect, ask the team to think of one thing they all have in common. (You can reject any

work-related suggestions, if you choose, to encourage your team get really creative!)

Values in Action

DEBRIEF

Although a lot of us have an idea of what a particular value means, it can be more difficult to show this in action. Thinking about what a value really looks and feels like can help us more easily integrate it into our lives and our work. Values can also have different meanings to different people – so it can be really important to discuss those differences to make sure we're all of the same page.

Focus	Duration	What You'll Need
Teamwork, Best Practice	45 minutes	Team members with camera phones and email, presentation software, whiteboard or flipchart

This activity takes a little more preparation to be effective, but is brilliant for demonstrating what values look like in action. It works very well in large groups of ten or more.

Ask your team to come up with their top five values for delivering great customer service, and jot these down on a flipchart or whiteboard (or, if you have company values, you can use these.) They should come up with a number of different values, for example, honesty, respect, diversity, excellence, teamwork.

Split the team into groups and assign each group one of the values.

Their job is to take a photo which shows this value in action. Encourage them to be creative with this – they can leave the room to go to a different place, use props, or rope in anyone else who could help.

Once they have taken their photo, ask them to email it to you.

Send the team to break once you have all the photos, and put them into a quick presentation while they are on break.

Once the team have returned, run the presentation. Ask each group to talk through how:

- How they came up with this idea
- What the photo represents
- How the photo sum up the value very well
- How the photo might be missing other ideas about what the value looks like

Ask the other groups some questions:

- What do they think of the picture?
- Is this an accurate representation of what the value looks like to you?
- What other photos might have represented this value?
- How could this photo have been improved, with more time/further props?

What Are You Doing?

DEBRIEF

It's obvious to all of us what processes we have, and why we have them. But to a customer approaching us for the first time, it's all alien to them.

Telling your customer what you're going to do, before you do it, and explaining things step by step will go a really long way towards helping them feel more relaxed about the service that we give.

Focus	Duration	What You'll Need
Communication	5-10 minutes	A measuring tape, random items of clothing and accessories

Ask for a volunteer and begin taking measurements and placing the items of clothing on them, encouraging them to put on the jacket, or hat, etc. without saying a single word.

After several uncomfortable minutes of measuring their arms and even the distance between their eyes, ask the volunteer how this felt. They should say it was pretty awkward!

Then, ask other participants what they think you were doing. They will probably just say you were being weird!

Ask another volunteer to stand up, and offer them the coat, asking questions like:

What do you think about this one? Does it fit well? Perhaps I should measure the width of your shoulders, is it okay if I do that?

Finish the roleplay and ask some questions:

- Ask the volunteer this time how it felt. They should say that it felt a lot better, since they knew what you were doing.
- Ask the team what you were doing. They should say that it's obvious you were measuring the volunteer for clothes.
- Then, ask the group how this relates to their customers. They should be able to identify that customers will be more comfortable if we talk them through what we're doing, or why we need to do a particular thing.

Worst Case Scenario

DEBRIEF

Even in an absolute worst case scenario, you all have the power to turn things around. Sometimes it takes a bit of time and thought to come up with a solution – however, even in time-pressured situations, remember you have the benefit of the rest of the team around you to help you out in pressured situations. You probably all found that your partners in this exercise had useful thoughts or suggestions – let your team members help you out if you do ever encounter anything close to your worst case scenario in future!

Focus	Duration	What You'll Need
Difficult Customers, Best Practice	30 minutes	Whiteboard or flipchart

Split your team into pairs.

Ask pairs to imagine their absolute worst case scenario customer interaction that could realistically happen in the course of their day to day work. The sky is the limit here – it's fine to be really creative with this! Ask them to discuss this in their pairs for a few minutes.

Then, ask them to discuss in their pairs a few questions. Give them ten minutes or so for this.

- What would this scenario feel like from the other person's perspective?
- What behavior from you, and the other person, would cause this situation to happen?
- How do you think you would handle this situation, realistically?
- What would be the best things to do in this situation?
- How could you make sure you do the best things in this situation?

Once finished, ask the team members to discuss their scenario and the types of things they thought about. Draw out any interesting points or themes.

Write Customer Letters

DEBRIEF

We've identified some great things here that we all do, which are all part of the service we provide. Although some interactions can be tough, we all have the ability to provide a great experience for our customers, and most customers are looking for these things when they approach us. Take these qualities into your next few customer conversations, and remember how these best practices can work to create really happy customers.

Focus	Duration	What You'll Need
Teamwork, Best Practice	10 minutes	Pen and paper

This activity is adapted from [Green Rock Customer Connect](#). This activity will help to raise team morale, and also engages your team in considering what a customer is really looking for when they seek help from one of your team members.

Split the group into pairs. Ask each pair to talk about a customer they spoke to recently, who they had a positive experience with. Have them share the customer's name, their most recent purchase or service that they needed, and what they needed help with.

Now ask the team to each compose thank you letters to your company from the perspective of this customer, writing about the other person's experience.

Ask the team imagine how this interaction made the customer's day better, and to praise the company's best points.

Then ask for volunteers to share their letters in order to prompt a discussion.

About Comm100

Comm100 Network Corporation is an award-winning global provider of enterprise live chat solution. Comm100 Live Chat is used by thousands of businesses worldwide to support their website visitors in real time so as to increase conversions, boost customer satisfaction and lower operating costs. With "100% communication, 100% success" as the company motto, Comm100 is committed to ensuring that transitioning human-to-human interactions to real-life success stories is always possible in a digital world.

Customers



Accreditations



Contact Us

TEL | (778) 785-0464

E-Mail | sales@comm100.com

Fax | (888) 837-2011

Web | www.comm100.com

Follow us on |    

Suite 238 – 1027 David Street Vancouver, British Columbia V6E 4L2 Canada

Copyright © 2017 Comm100. All Rights Reserved.

All Comm100 brand and product names are trademarks or registered trademarks of Comm100 Network Corporation in Canada and other countries. All other trademarks or registered trademarks are property of their respective owners.