



524

624

739

839

1039

PARKER® GRAIN CARTS



Built on Tradition...Engineered for Tomorrow!

Farmers have relied on Parker® products to meet their grain-handling needs for more than 40 years. The latest generation of Parker grain carts continue to increase harvesting efficiency and productivity.

The Perfect Choice For Your Harvesting Team

Parker grain carts are well-known for their outstanding performance and durability. The Parker 524, 624, 739, 839 and 1039 grain carts expand on these enduring traits. Choose the model that best meets your needs.

524

624

739

839

1039



Model 739
750 bu. capacity



Model 524
500 bu. capacity



Model 624
600 bu. capacity



Special features are engineered into the Parker 524, 624, 739, 839 and 1039 carts, making loading, unloading and transporting your grain a fast and convenient process.



Model 839
850 bu. capacity

Engineered for added strength

Bridge construction from hitch to axle provides additional support and durability.

A vertical rib in the center of the sideboards gives our carts additional strength and support when they are full.

The PTO shear bolt design helps protect the gearbox and driveline and requires minimal maintenance.





All carts feature an observation ladder and inspection window(s) for quick, convenient and safer viewing of cart contents.



The auger spotlight provides better visibility for nighttime unloading.



The Parker corner auger allows greater visibility from the tractor cab, making unloading easier. Compared to other carts, the length of our side-folding corner auger allows it to reach to the center of a truck, as its length is not restricted by the width of the cart.

Hydraulic spout diverts grain flow for easier unloading (739, 839 and 1039 models).

The one-piece, 1½"-thick laser-cut drive cog provides 50 percent less impact and wearing of parts.

Model 1039
1000+ bu. capacity



A swivel hitch makes hookup easy and keeps the cart level in transport, ensuring stability. Either a single-tang or clevis hitch is available.

A unique sump design funnels all grain to one spot, helping to feed the auger for faster unloading and complete cleanout.



When the auger is folded, the 1¾" retaining pin, welded to the cart, ensures a secure fit while in storage or transport.



Other built-in standard features

Channel guides for electrical wires provide a secure fit while also allowing easy access.



LED lighting package with reflective striping is designed to meet new state requirements. Sidemarker lights that extend over the wheels are visible from both the front and the rear.



Standard 7-prong electric connector makes hookup easy and comes with a convenient storage holder with cover that keeps it safely out of the way when not in use.



Hose holders provide convenient placement when not in use and easy identification when hooking to tractor.



Engineered for a longer life



A 3,000-PSI hydraulic cylinder, with nickel undercoating and chrome plating on the rod, ensures the best prevention against scoring, rusting and pitting. The hydraulic locking system keeps the upper auger tight to the lower auger, ensuring no grain seepage.

Your Parker grain cart will look its best for years to come with its powder-coated surfaces and high-gloss finish in choice of deep red or green. Silicone-sealed seams offer additional corrosion resistance.

Engineered for safety

An easy-to-use transport chain is standard on all models. This unique chain-anchoring system is built into the design of each cart to provide additional strength and safety and to ensure secure hookup.



The observation ladder features a nonslip surface to enhance operator safety.

UHarvest™ Data Management System

UHarvest™ data management system provides full ISOBUS terminal or tablet operation while it automatically stores detailed information about each load. The UHarvest system automatically records each bushel unloaded from the grain cart by grower, farm, field, truck loaded, grain destination and variety.



An optional cart-mounted moisture sensor can also automatically calculate dry bushels.

Other options

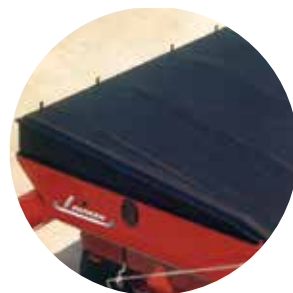

Weatherguard tarps for protecting grain from adverse weather conditions.



Model 640 scale for accurate in-field weighing.



Hydraulic drive for tractors without a PTO.

Dual-wheel option for greater flotation available on models 739 and 839.



grain cart specifications:

Model	524	624	739	839	1039
Capacity*	500 bu.	600 bu.	750 bu.	850 bu.	1000+ bu.
Unloading time	290 bu./min.	290 bu./min.	400 bu./min.	400 bu./min.	400 bu./min.
Hitch, standard	Clevis	Single	Single	Single	Single
Approx. empty weight	6,100 lbs.	6,300 lbs.	8,740 lbs.	9,200 lbs.	12,330 lbs.
Est. loaded tongue weight	3,200 lbs.	3,600 lbs.	3,820 lbs.	5,200 lbs.	6,100 lbs.
Auger size	14"	14"	17"	17"	17"
Tires, standard	20.8 x 38 R-1	24.5 x 32 R-3	24.5 x 32 R-3	30.5 x 32 R-3	900/60 x 32 R-1
Spindle diameter**	27/8"	33/4"	33/4"	33/4"	33/4"
PTO yoke, standard	13/8" x 21 spline	13/8" x 21 spline	13/4" x 20 spline	13/4" x 20 spline	13/4" x 20 spline
Lights, standard	Tail/turn signals with 7-prong connector				
Horsepower required	130+	140+	150+	180+	200+
A	11	11' 6"	12' 4"	12' 8"	12' 6"
B	9' 8"	10' 2"	10' 10"	11' 1"	11' 6"
C	11' 10"	11' 10"	11' 11"	11' 11"	11' 11"
D	10'	10'	10'	10'	11' 4"
E	13' 9"	13' 9"	15' 3"	15' 3"	18' 3"
F	11' 9"	11' 11"	12' 4"	12' 7"	14' 4"
G	7' 3"	7' 3"	7' 6"	7' 6"	7' 11"
H	13' 2"	13' 2"	14' 6"	14' 7"	14' 11"
I	1' 6"	1' 6"	1' 7"	1' 6"	1' 4"
J	1' 8"	1' 8"	1' 8"	1' 8"	1' 6"
K	19' 5"	19' 5"	24' 6"	24' 6"	27' 7"
L	13' 9"	13' 9"	16'	16'	21' 6"
M	—	—	15'	15'	15'
N	—	—	16' 6"	16' 6"	—

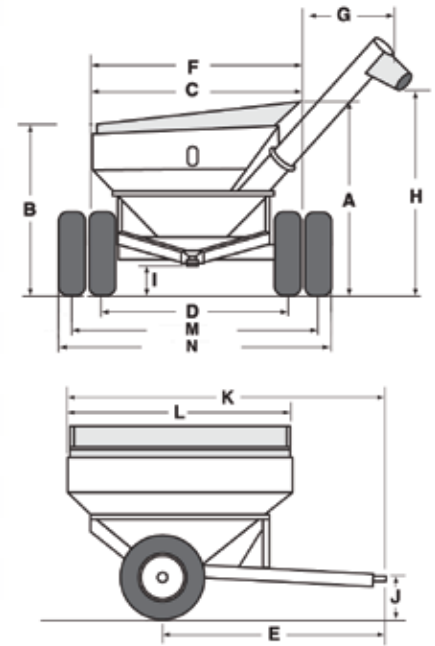

20.8 x 38	18.76	—	24.80	—	—
23.1 x 26	17.20	—	—	—	—
24.5 x 32	16.49	19.29	24.79	27.57	—
30.5 x 32	13.62	16.05	20.59	22.89	—
35.5 x 32	—	—	13.56	15.36	18.52
900/60 x 32	—	—	18.32	20.81	25.09
1050/50 x 32	—	—	—	—	16.80
Duals 420/80 x 46	—	—	16.20	17.90	—
Duals 520/85 x 42	—	—	—	12.80	—

The chart to the left illustrates the relative ground pressure calculated at the 3" soil penetration level. These charts are useful as a comparison guide for the various undercarriage options available by model.

* Capacities measured with #2 corn at 15% moisture (56 lb. test weight).
 ** Constructed of special alloy steel.

As we continually strive to improve our products and available equipment, specifications contained herein are subject to change without notice.

