

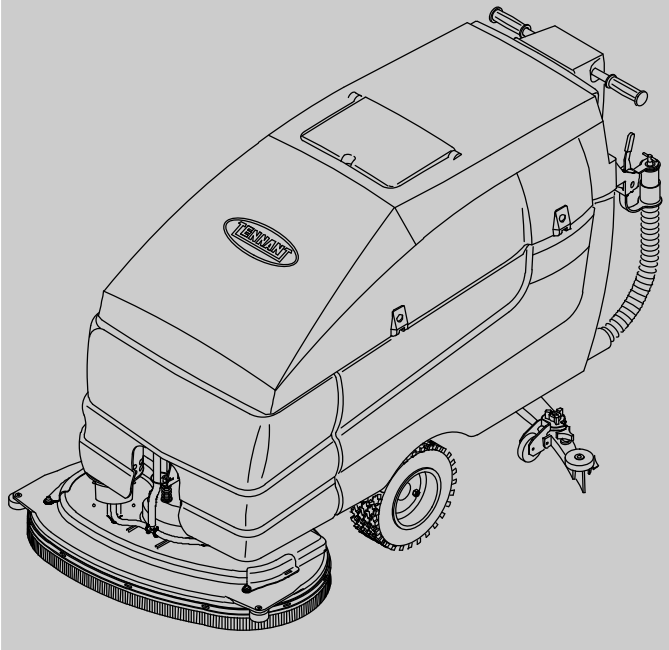

5680

(Battery)

English **EN**
Operator Manual



CE



To view, print or download
the latest manual, visit:

www.tennantco.com/manuals

330459
Rev. 11 (12-2013)



INTRODUCTION



This manual is furnished with each new model. It provides necessary operation and maintenance instructions.



Read this manual completely and understand the machine before operating or servicing it.

This machine will provide excellent service. However, the best results will be obtained at minimum costs if:

- The machine is operated with reasonable care.
- The machine is maintained regularly - per the machine maintenance instructions provided.
- The machine is maintained with manufacturer supplied or equivalent parts.

 <p>PROTECT THE ENVIRONMENT</p> <p>Please dispose of packaging materials, used components such as batteries and fluids in an environmentally safe way according to local waste disposal regulations.</p>  <p>Always remember to recycle.</p>	<p style="text-align: center;">MACHINE DATA</p> <p>Please fill out at time of installation for future reference.</p> <p>Model No. – _____</p> <p>Serial No. – _____</p> <p>Installation Date – _____</p>
---	---

INTENDED USE

The 5680 walk behind scrubber is designed to scrub hard surfaces (concrete, asphalt, stone, synthetic, etc) in an indoor environment. Typical applications include hotels, schools, hospitals, factories, shops, offices, and rental businesses. Do not use this machine on carpeted surfaces. Use only recommended pads and commercially available floor cleaners intended for machine application. Do not use this machine other than described in this Operator Manual.

TENNANT N.V.
Industrielaan 6 5405 AB
P.O. Box 6 5400 AA Uden–The Netherlands

europa@tenantco.com
www.tenantco.com

Specifications and parts are subject to change without notice.

Original instructions, copyright © 2008, 2013 TENNANT Company, Printed in The Netherlands.

 <p>TENNANT N.V. Industrielaan 6 5405 AB P.O. Box 6 5400 AA Uden – The Netherlands Uden, 21–05–2010</p> 	<p>DECLARATION OF CONFORMITY FOR MACHINERY (according to Annex II A of the Machinery Directive)</p> <p>Herewith declares, on our own responsibility, that the machinery</p> <p>5680</p> <ul style="list-style-type: none">– is in conformity with the provisions of the Machinery Directive (2006/42/EC), as amended and with national implementing legislation– is in conformity with the provisions of the Electro Magnetic Compatibility Directive 2004/108/EC <p>and that</p> <ul style="list-style-type: none">– the following harmonized standards or parts of these standards have been applied: EN ISO 14121–1, EN 1037, EN 60335–1, EN 60204–1, EN ISO 13849–1, EN ISO 13849–2, EN 60529, EN ISO 4413, EN 349, EN 55012, EN 61000–6–2, EN ISO 11201, EN ISO 4871, EN ISO 3744*, EN ISO 13059*, EN ISO 3450, EN 60335–2–72.– the following national standards or parts of these standards have been used:
---	--

CONTENTS

	Page		Page
SAFETY PRECAUTIONS	3	SCRUB HEAD	46
OPERATION	6	DISK BRUSH SCRUB HEAD SKIRT	46
MACHINE COMPONENTS	6	CYLINDRICAL BRUSH SCRUB HEAD	
CONTROL PANEL SYMBOLS	7	SKIRTS	46
CONTROLS AND INSTRUMENTS	8	ADJUSTING THE SCRUB HEAD	
STEERING HANDLES	9	SKIRTS	46
ON-OFF KEY SWITCH	10	REPLACING THE SCRUB HEAD	
SCRUB SWITCH	11	SKIRTS	46
SCRUB HEAD STRAP (DISC HEAD) ...	11	REMOVING OR REPLACING THE	
SQUEEGEE LEVER	11	SCRUB HEAD	47
HOURMETER	12	LEVELING THE SCRUB HEAD	49
BATTERY DISCHARGE INDICATOR	12	SCRUB BRUSHES AND PADS	50
FaST SWITCH (OPTION)	12	DISK BRUSHES	50
ec-H ₂ O SWITCH (OPTION)	13	REPLACING THE DISK BRUSHES OR	
EMERGENCY SHUT-OFF BUTTON	13	PADS	50
SOLUTION FLOW LEVER	14	CYLINDRICAL BRUSHES	54
SOLUTION TANK HOSE	15	REPLACING THE CYLINDRICAL	
RECOVERY TANK DRAIN HOSE	15	BRUSHES	54
SUPPORT ARM	15	CHECKING AND ADJUSTING	
STOP ARM	16	CYLINDRICAL BRUSH PATTERN ...	56
SQUEEGEE DOWN PRESSURE CAMS	16	FaST SYSTEM (OPTION)	58
PARKING BRAKE	16	FaST SYSTEM MAINTENANCE	58
HOW THE MACHINE WORKS	17	FaST SYSTEM FILTER SCREEN	59
FaST SCRUBBING SYSTEM (OPTION) .	18	FaST SUPPLY HOSE CONNECTOR	59
ec-H ₂ O SYSTEM (OPTION)	18	ec-H ₂ O SYSTEM (OPTION)	60
BRUSH AND PAD INFORMATION	19	ec-H ₂ O MODULE FLUSH	
WHILE OPERATING THE MACHINE	20	PROCEDURE	60
PRE-OPERATION CHECKLIST	21	SQUEEGEE	61
INSTALLING FaST PAK AGENT		REMOVING THE SQUEEGEE	
(OPTION)	22	ASSEMBLY	61
STARTING THE MACHINE	24	INSTALLING THE SQUEEGEE	
FILLING THE TANKS	24	ASSEMBLY	62
SCRUBBING	26	LEVELING THE SQUEEGEE	63
DOUBLE SCRUBBING	29	ADJUSTING SQUEEGEE BLADE	
STOP SCRUBBING	30	DEFLECTION	64
DRAINING AND CLEANING THE TANKS	31	SQUEEGEE BLADES	65
RECOVERY TANK	31	REPLACING OR ROTATING THE REAR	
SOLUTION TANK	35	SQUEEGEE BLADE	65
STOP THE MACHINE	36	REPLACING OR ROTATING THE FRONT	
MACHINE TROUBLESHOOTING	37	SQUEEGEE BLADE	67
MAINTENANCE	39	BELTS AND CHAINS	68
MAINTENANCE CHART	39	BRUSH DRIVE BELT	68
LUBRICATION	41	STATIC DRAG CHAIN	68
REAR CASTERS	41	TIRES	69
TRANSAXLE	41	PUSHING AND TRANSPORTING THE	
BATTERIES	42	MACHINE	70
CHECKING THE ELECTROLYTE		PUSHING THE MACHINE	70
LEVEL (WET / LEAD ACID		TRANSPORTING THE MACHINE	70
BATTERIES ONLY)	42	MACHINE JACKING	72
CHECKING CONNECTIONS / CLEANING	42	STORAGE INFORMATION	73
CHARGING THE BATTERIES	43	FREEZE PROTECTION	73
CIRCUIT BREAKERS	44	FLUSHING ANTIFREEZE FROM ec-H ₂ O	
ELECTRIC MOTORS	45	MODULE	74

CONTENTS

	Page
SPECIFICATIONS	75
GENERAL MACHINE DIMENSIONS/ CAPACITIES	75
GENERAL MACHINE PERFORMANCE .	75
FaST SYSTEM (OPTION)	76
ec-H ₂ O SYSTEM (OPTION)	76
POWER TYPE	77
TIRES	77
MACHINE DIMENSIONS	78

IMPORTANT SAFETY INSTRUCTIONS – SAVE THESE INSTRUCTIONS

The following symbols are used throughout this manual as indicated in their description:



WARNING: To warn of hazards or unsafe practices that could result in severe personal injury or death.

FOR SAFETY: To identify actions that must be followed for safe operation of equipment.

The following information signals potentially dangerous conditions to the operator. Know when these conditions can exist. Locate all safety devices on the machine. Report machine damage or faulty operation immediately.



WARNING: Batteries emit hydrogen gas. Explosion or fire can result. Keep sparks and open flame away. Keep covers open when charging.



WARNING: Flammable materials can cause an explosion or fire. Do not use flammable materials in tank(s).



WARNING: Flammable materials or reactive metals can cause an explosion or fire. Do not pickup.

FOR SAFETY:

1. **Do not operate machine:**
 - Unless trained and authorized.
 - Unless operator manual is read and understood.
 - Under the influence of alcohol or drugs
 - While using a cell phone or other types of electronic devices
 - Unless mentally and physically capable of following machine instructions.
 - If it is not in proper operating condition.
 - In areas where flammable vapors/liquids or combustible dusts are present.
 - In areas that are too dark to safely see the controls or operate the machine unless equipped with operating lights.
 - In areas with possible falling objects.
2. **Before starting machine:**
 - Check machine for fluid leaks.
 - Make sure all safety devices are in place and operate properly.
3. **When using machine:**
 - Use only as described in this manual.
 - Go slowly on inclines and slippery surfaces.
 - Wear non-slip shoes.
 - Reduce speed when turning.
 - Use care when reversing machine.
 - Do not carry passengers on machine.
 - Keep children and unauthorized persons away from machine.
 - Do not allow machine to be used as a toy.
 - Always follow safety and traffic rules.
 - Report machine damage or faulty operation immediately.
 - Follow mixing, handling and disposal instructions on chemical containers.
 - Follow site safety guidelines concerning wet floors.

SAFETY PRECAUTIONS

4. Before leaving or servicing machine:
 - Stop on level surface.
 - Set the parking brake (if so equipped).
 - Turn off machine and remove key.
5. When servicing machine:
 - All work must be done with sufficient lighting and visibility.
 - Keep work area well ventilated.
 - Avoid moving parts. Do not wear loose clothing, jewelry and secure long hair.
 - Block machine tires before jacking machine up.
 - Jack machine up at designated locations only. Support machine with jack stands.
 - Use hoist or jack that will support the weight of the machine.
 - Do not power spray or hose off machine.
 - Disconnect battery connections before working on machine.
 - The use of incompatible battery chargers may damage battery packs and potentially cause a fire hazard.
 - Inspect charger cord regularly for damage.
 - Do not disconnect the charger DC cord from the machine receptacle when the charger is operating. Arcing may result. If the charger must be interrupted during charging, disconnect the AC power supply cord first.
 - Avoid contact with battery acid.
 - Battery installation must be done by trained personnel.
 - Use a hoist or adequate assistance when lifting batteries.
 - All repairs must be performed by a trained service mechanic.
 - Do not modify the machine from its original design.
 - Use Tennant supplied or approved replacement parts.
 - Wear personal protective equipment as needed and where recommended in this manual.
6. When loading/unloading machine onto/off truck or trailer.
 - Drain tanks before loading machine.
 - Lower scrub head and squeegee before tying down machine.
 - Turn off machine and remove key.
 - Use ramp, truck or trailer that will support the weight of the machine and operator.
 - Do not push the machine onto/off the truck or trailer unless the load height is 380 mm (15 in) or less from the ground.
 - Set parking brake after machine is loaded (if so equipped).
 - Block machine tires.
 - Tie machine down to truck or trailer.



For Safety: wear hearing protection.



For Safety: wear protective gloves.



For Safety: wear eye protection.



For Safety: wear protective dust mask.

SAFETY PRECAUTIONS

The safety labels appear on the machine in the locations indicated. If these or any label becomes damaged or illegible, install a new label in its place.

WARNING LABEL – Flammable materials or reactive metals can cause explosion or fire. Do not pick up.



Located on the underside of the solution tank cover.

FOR SAFETY LABEL – Read manual before operating machine.



Located on the operator console.

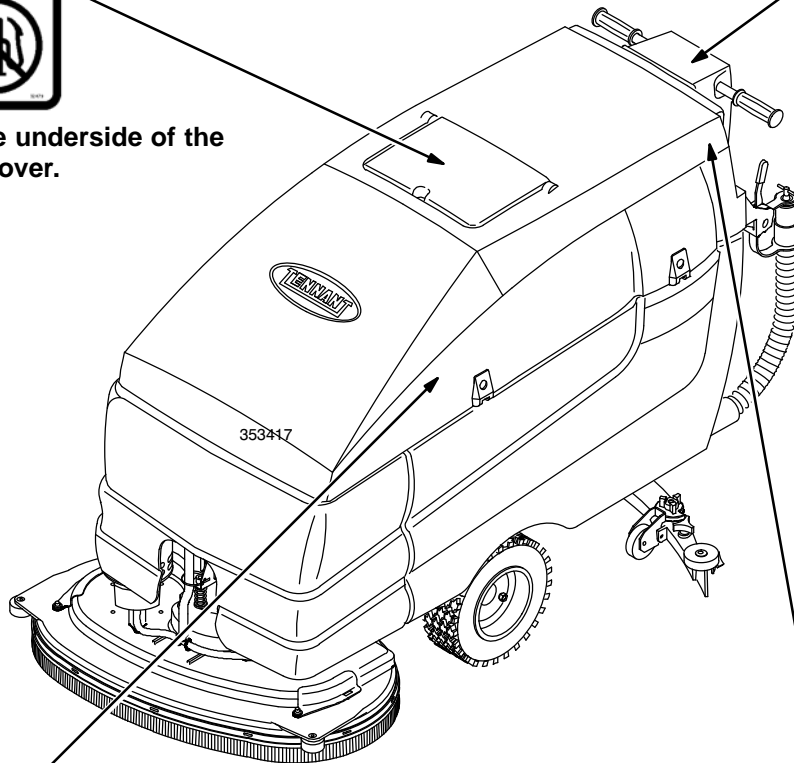

WARNING LABEL – Batteries emit hydrogen gas. Explosion or fire can result. Keep sparks and open flame away. Keep covers open when charging.



Located on the underside of the solution tank.

WARNING LABEL – Flammable materials can cause explosion or fire. Do not use flammable materials in tank.



Located on the operator console.

MACHINE COMPONENTS

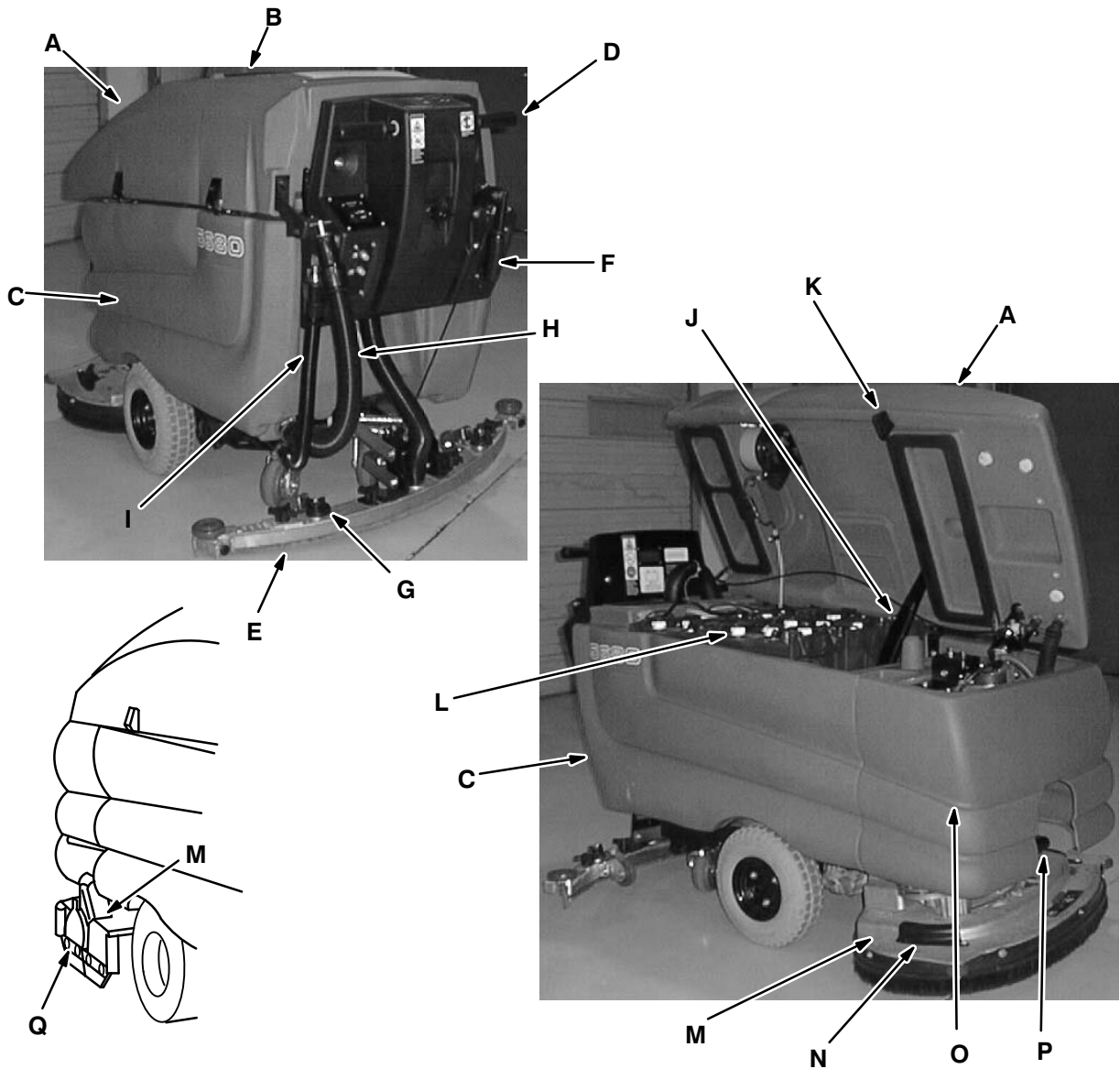

- A. Solution tank
- B. Solution tank fill opening
- C. Recovery tank
- D. Steering handles
- E. Squeegee
- F. Squeegee lever
- G. Squeegee down pressure cams
- H. Recovery tank drain hose
- I. Solution tank hose
- J. Support arm
- K. Stop arm
- L. Batteries
- M. Scrub head
- N. Scrub brush access cover
- O. FaST solution system (option)
ec-H2O System Module (option)
- P. Heavy duty scrub head strap
- Q. Scrub brush idler door

CONTROL PANEL SYMBOLS

These symbols identify controls and displays on the machine:



Key switch



Variable flow or rate



Solution flow



Scrub brushes down and on



Scrub brushes up and off



Heavy scrub brush down pressure



Circuit breaker #1–scrub head actuator



Circuit breaker #2–vacuum fan motor



Circuit breaker #3–machine propel



Circuit breaker #4–left brush motor



Circuit breaker #5–right brush motor



Circuit breaker #6–FaST



Circuit breaker #6–ec-H2O

CONTROLS AND INSTRUMENTS

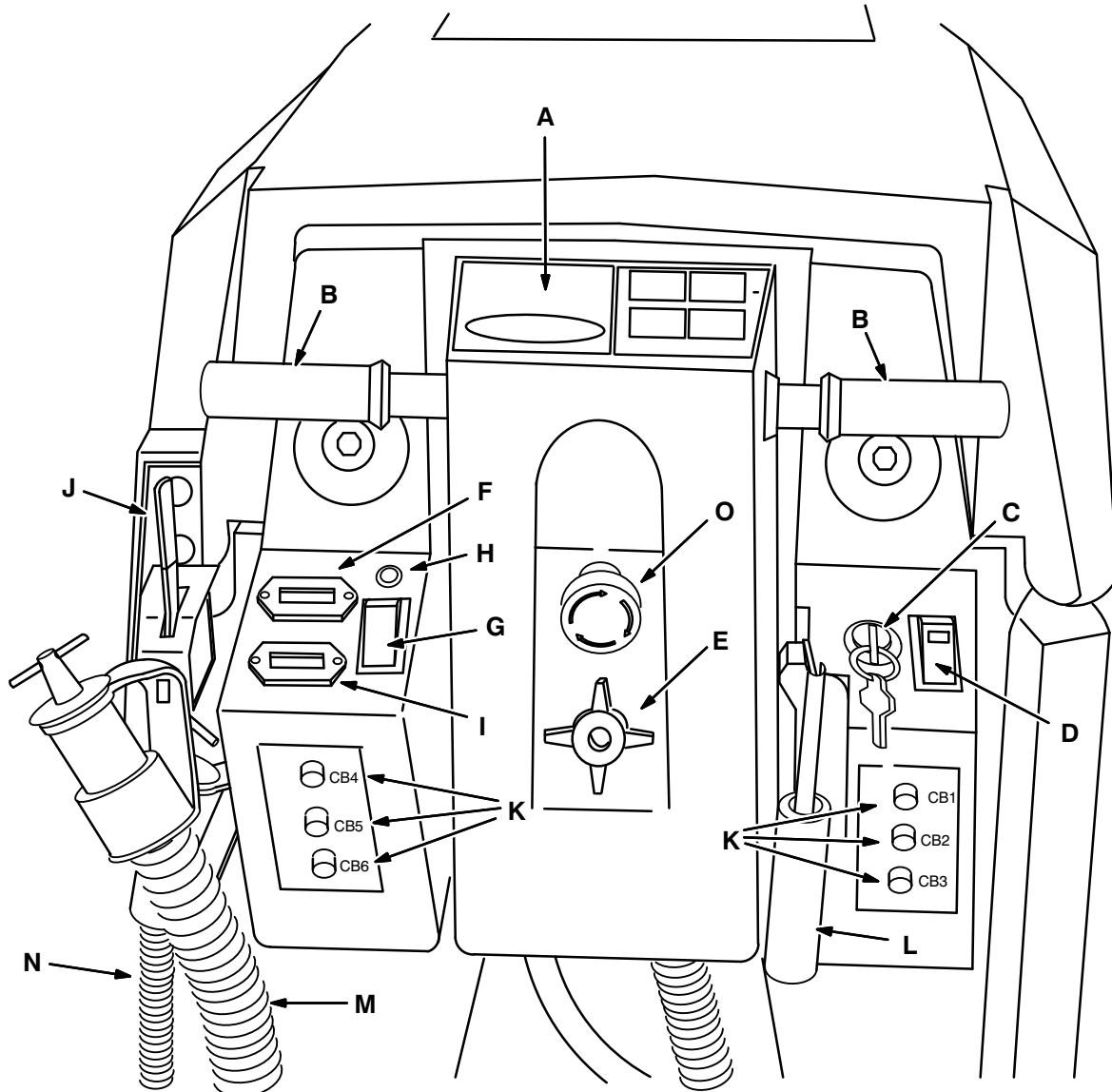

10345

- A. Operation label
- B. Steering handles
- C. On-off key switch
- D. Scrub switch
- E. Console height adjustment knob
- F. Hourmeter
- G. FaST system on/off switch (option)
ec-H₂O system on/off switch (option)
- H. ec-H₂O system indicator light (option)
- I. Battery discharge indicator
- J. Solution flow lever
- K. Circuit breakers
- L. Squeegee lever
- M. Recovery tank drain hose
- N. Solution tank drain hose
- O. Emergency shut-off button

STEERING HANDLES

The steering handles control the machine speed and direction.

Forward: Rotate the steering handles forward. The further forward you rotate the steering handles, the faster the machine will go.

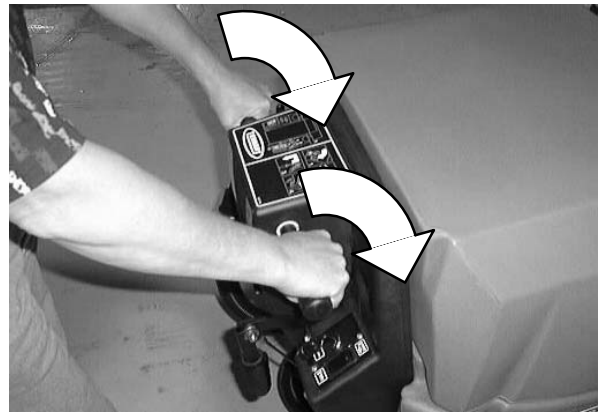

Backward: Rotate the steering handles backwards toward you.

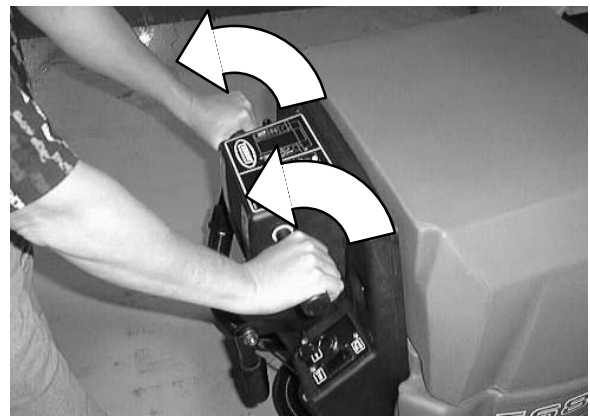

Turning: Push the machine in the direction of the turn with the steering handles. The machine will turn on the swivel casters.

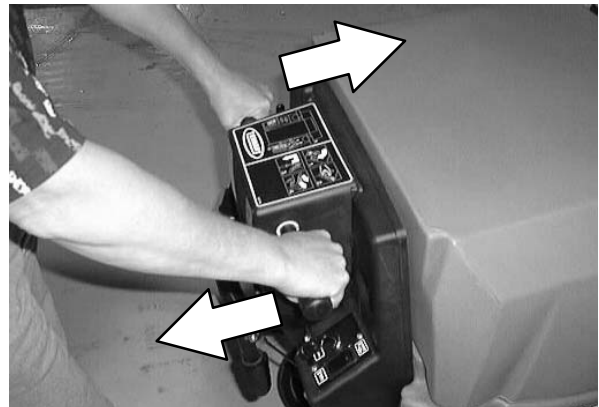

OPERATION

Stop: Release the steering handles.



The steering console height is adjustable.

Adjust: Turn the console adjustment knob counterclockwise to loosen the knob. Move the console up or down to the desired height. Then turn the knob clockwise to tighten the knob, and lock the console in position.

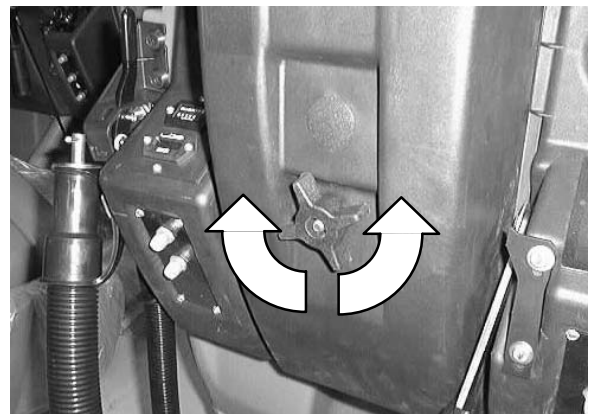

ON-OFF KEY SWITCH

The on-off key switch controls machine power with a key.

On: Turn the key to the right.

Off: Turn the key to the left.

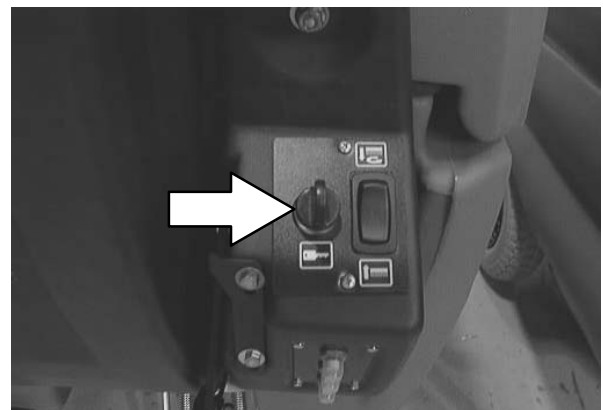

SCRUB SWITCH

The scrub switch controls the scrubbing operations.

Lower brushes and start scrubbing: Press the top of the switch.

Raise brushes and stop scrubbing: Press the bottom of the switch.

NOTE: The scrub brushes do not start until the steering handles are rotated forward or backward.

NOTE: The scrub switch also controls the FaST/ec-H2O system (option) when the FaST/ec-H2O system is enabled with the FaST/ec-H2O switch.

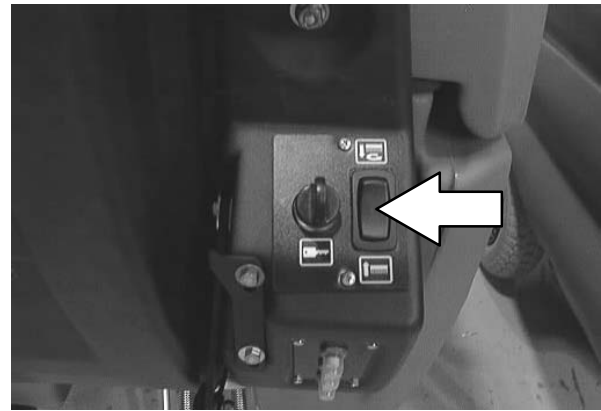
**SCRUB HEAD STRAP (DISC HEAD)**

The scrub head strap increases the scrub head pressure and puts the scrub head into heavy scrub mode.

The heavy scrub mode is used when deep scrubbing or floor stripping is necessary.

Start heavy scrub mode: With the scrub head in the up position, pull out on the scrub head strap until the scrub head drops into place. Lower the brushes and start scrubbing.

Stop heavy scrub mode: Press the bottom of the scrub switch. The scrub head will reset when it raises and stops scrubbing. When it is started again, the scrub head will operate at daily scrubbing pressure.

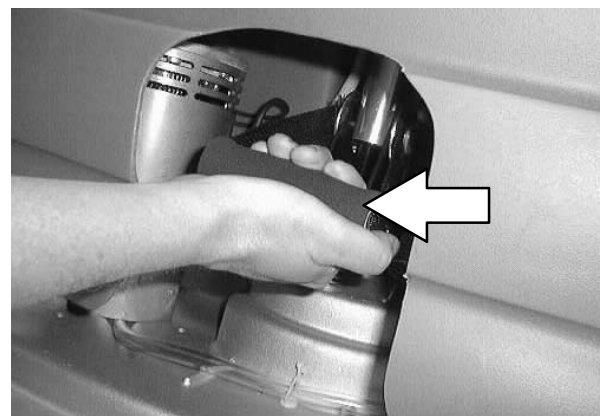
**SQUEEGEE LEVER**

The squeegee lever controls the squeegee and the vacuum system.

Lower squeegee and start vacuum: Move the squeegee lever up and to the left to unlock it, and then release the lever.

Raise squeegee and stop vacuum: Pull the lever up and move it to the right to lock the lever in the up position.

NOTE: Raise the squeegee before reversing the machine.

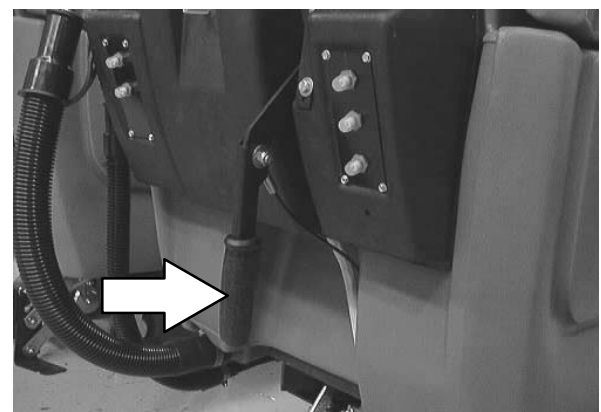

OPERATION

HOURLMETER

The hourmeter records the number of hours the machine has been powered on. This information is useful when servicing the machine.



BATTERY DISCHARGE INDICATOR

The battery discharge indicator shows the charge level of the batteries.

When the batteries are fully charged, the indicator on the far right is lit. As the batteries discharge, the indicator will move along the display to the left. Recharge the batteries when the indicator flashes.

NOTE: The battery discharge indicator will not reset from the flashing indicator unless the batteries have been fully charged.



FaST SWITCH (OPTION)

The FaST switch (option) enables the FaST (Foam Scrubbing Technology) system. When the FaST system is enabled, it is turned on and off with the scrub switch.

Enable the FaST system: Press the top of the FaST switch.

Enable conventional scrubbing: Press the bottom of the FaST switch.

NOTE: Disable the FaST system before using the machine for conventional scrubbing.

NOTE: The FaST system will not start until the steering handles are rotated forward or backward.

NOTE: Do not enable the FaST system with conventional cleaning detergents in the solution tank. Drain, rinse and refill the solution tank with clear cool water only before operating the FaST system. Conventional cleaning detergents/restorers may cause failure to the FaST solution system.

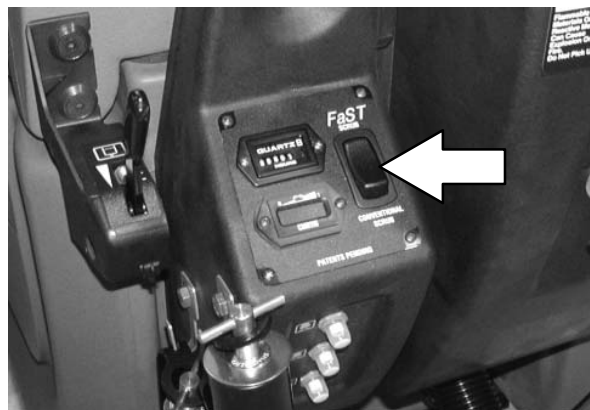

ec-H2O SWITCH (OPTION)

The *ec-H2O* switch (option) enables the *ec-H2O* (electrically converted water) system. When the *ec-H2O* system is enabled, it is turned on and off with the scrub switch.

Enable the *ec-H2O* system: Press the top of the *ec-H2O* switch.

Enable conventional scrubbing: Press the bottom of the *ec-H2O* switch.

*NOTE: Disable the *ec-H2O* system before using the machine for conventional scrubbing.*

*NOTE: The *ec-H2O* system will not start until the machine starts scrubbing.*

*NOTE: Do not enable the *ec-H2O* system with conventional cleaning detergents in the solution tank. Drain, raise and refill the solution tank with clear cool water only before operating the *ec-H2O* system. Conventional cleaning detergents/restorers may cause failure to the *ec-H2O* solution system.*

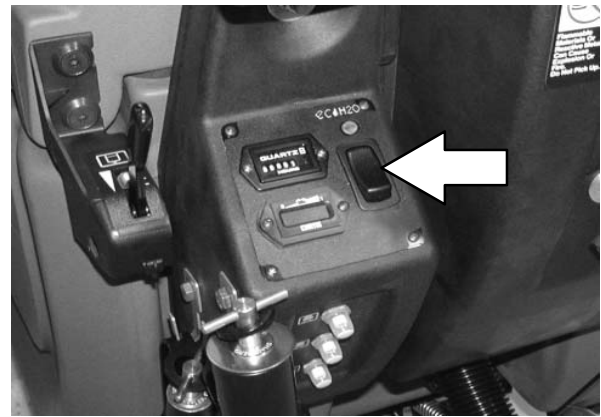

EMERGENCY SHUT-OFF BUTTON

The *Emergency shut-off button* immediately stops all power to the machine.

Stop machine power: Push the *Emergency shut-off button*.

Restart machine power: Turn the *Emergency shut-off button* to the right to release the button. Turn the key switch to the Off position, then turn the key fully clockwise and release it to the On position.

Only use this button in the event of an emergency. It is not intended for routine machine shutdown.

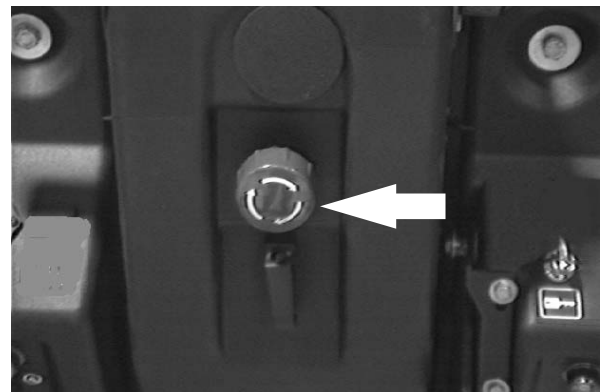

SOLUTION FLOW LEVER

The solution flow lever controls the amount of solution flow to the floor.

Increase: Push the lever forward.

Decrease: Pull the lever backward.

NOTE: A solenoid valve dispenses the solution to the scrub head. The valve opens when the steering handles are rotated forward, and closes when the steering handles are released in neutral position.

*NOTE: When using the FaST or *ec-H2O* system (option), the solution flow lever is nonfunctional. The FaST and *ec-H2O* system flow rates are pre-set. The *ec-H2O* module has optional flow rate settings. If solution flow adjustments are required, contact an Authorized Service Center.*



OPERATION

SOLUTION TANK HOSE

The solution tank hose is used to drain the solution tank. The drain hose plug is removed by turning the plug latch to loosen the plug and pulling the plug out of the drain hose. The drain hose is plugged by placing the hose plug in the end of the hose and turning the plug latch to tighten the plug.

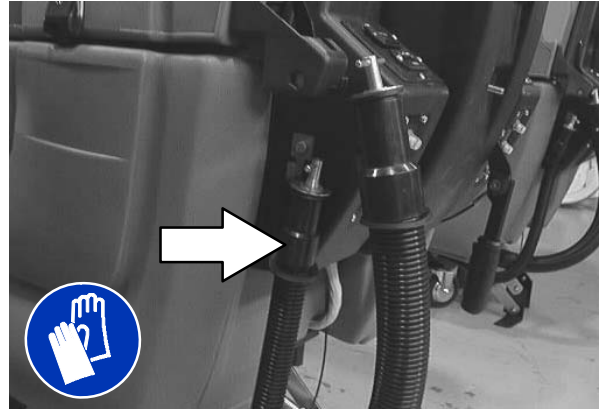

RECOVERY TANK DRAIN HOSE

The recovery tank drain hose is used to drain the recovery tank. The drain hose plug is removed by turning the plug latch to loosen the plug and pulling the plug out of the drain hose. The drain hose is plugged by placing the hose plug in the end of the hose and turning the plug latch to tighten the plug.

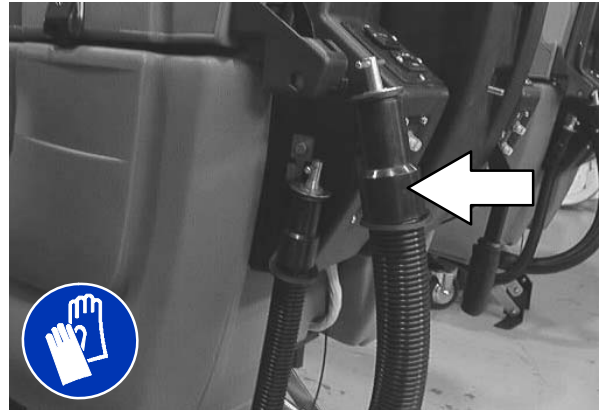

SUPPORT ARM

The support arm holds up the solution tank when the tank is lifted. The support arm engages when the solution tank is lifted all the way open. The arm is released by pulling up on it.

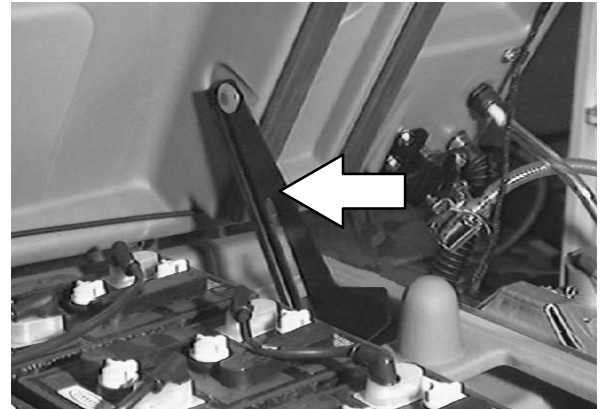

STOP ARM

The stop arm prevents the solution tank from fully closing when the tank is lowered. Push the arm in to lower the solution tank completely.

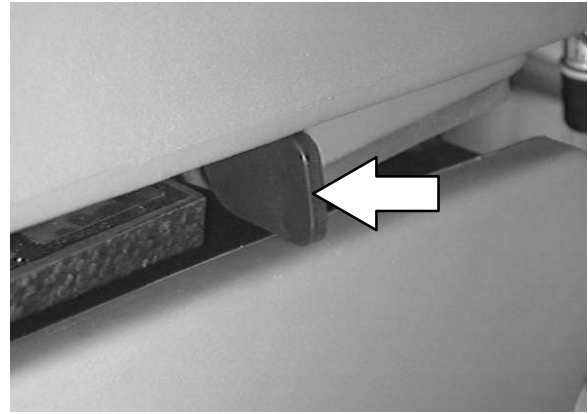
**SQUEEGEE DOWN PRESSURE CAMS**

The squeegee down pressure cams adjust the squeegee deflection along the entire length of the squeegee.

Increase: Turn the cams clockwise.

Decrease: Turn the cams counter-clockwise.

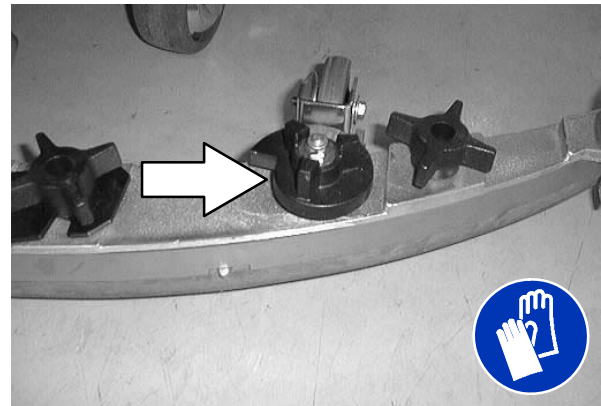
**PARKING BRAKE**

The parking brake is controlled with a foot pedal and a release lever located by the squeegee.

Set: Push down on the foot pedal.

Release: Pull up on the release lever.



HOW THE MACHINE WORKS

The scrub components of the machine are a solution tank, scrub brushes or pads, a squeegee, a vacuum fan, and a recovery tank.

Water and detergent, from the solution tank, flow to the floor through a solution valve to the scrub brushes or pads. The brushes or pads scrub the floor. As the machine is moved forward the squeegee wipes the dirty solution off the floor, which is then picked up and drawn into the recovery tank.

The steering handles control the direction and speed of the machine in forward or reverse. By rotating the steering handles forward, the machine propels forward. By rotating the handles towards you, the machine propels backward.

Three different widths of scrub heads and squeegees are available for the machine.

The scrub head widths are as follows; the model 700 (700 mm), the model 800 (800 mm), and the model 900 (900 mm). The 700 mm squeegee is used with the 700 model scrub head, as well as the 800 mm with the model 800, and the 900 mm with the model 900.



FaST SCRUBBING SYSTEM (OPTION)

The FaST (Foam Scrubbing Technology) system operates by injecting the FaST PAK concentrate agent (A) into the system with a small amount of water and compressed air. This mixture creates a large volume of expanded wet foam.

The expanded foam mixture is then dispersed onto the floor (B) while the machine is scrubbing. When the squeegee picks up the mixture, the patented foaming agent has collapsed and is recovered into the recovery tank.

The FaST system can be used with all double scrubbing and heavy duty scrubbing applications.

NOTE: Do not enable the FaST system with conventional cleaning detergents in the solution tank. Drain, raise and refill the solution tank with clear cool water only before operating the FaST system. Conventional cleaning detergents/restorers may cause failure to the FaST solution system.

NOTE: Storage or transporting machines equipped with FaST in freezing temperatures requires special procedures. Check with a TENNANT representative for advice.

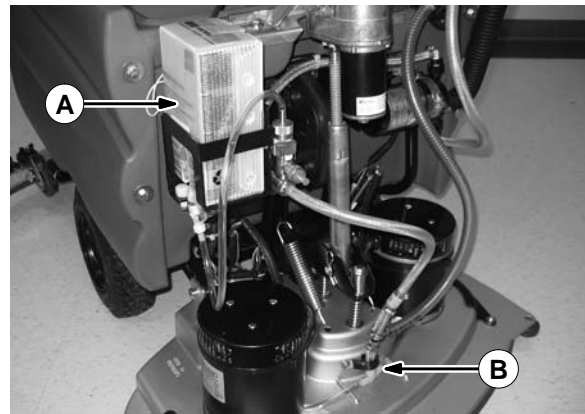

ec-H2O SYSTEM (OPTION)

The ec-H2O (electrically converted water) system operates by producing electrically activated water for cleaning.

Normal water passes through a module where it is oxygenated and charged with an electric current. The electrically converted water changes into a blended acidic and alkaline solution forming a neutral pH cleaner. The converted water attacks the dirt, breaks it into smaller particles, and pulls it off the floor surface allowing the machine to easily scrub away the suspended soil. The converted water then returns to normal water in the recovery tank.

The ec-H2O system can be used with all double scrubbing applications.

NOTE: Do not enable the ec-H2O system with conventional cleaning detergents in the solution tank. Drain, raise and refill the solution tank with clear cool water only before operating the ec-H2O system. Conventional cleaning detergents/restorers may cause failure to the ec-H2O solution system.

NOTE: Storage or transporting machines equipped with ec-H2O in freezing temperatures requires special procedures. Check with a TENNANT representative for advice.

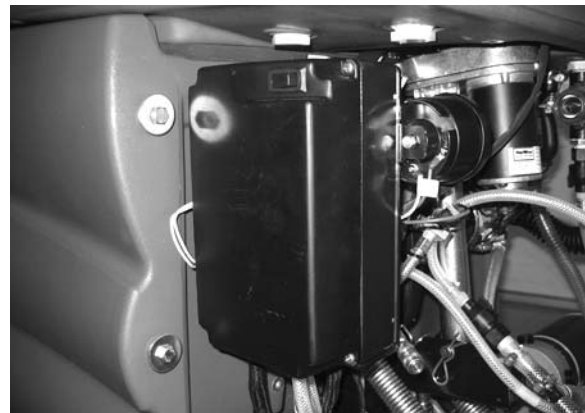

BRUSH AND PAD INFORMATION

For best results, use the appropriate brush or pad for the cleaning application. Listed below are brushes and pads and the applications for which each is best suited.

NOTE: The amount and type of soilage play an important role in determining the type of brush or pad to use. Contact a Tennant representative for specific recommendations.

Polypropylene brush (Cylindrical and Disk) – General purpose polypropylene bristles lift lightly compacted dirt without scuffing high-gloss coated floors.

Nylon brush (Cylindrical and Disk) – Softer nylon bristles are recommended for scrubbing coated floors. Cleans without scuffing.

Super AB brush (Cylindrical and Disk) – Nylon fiber with an abrasive grit to remove stains and compacted dirt. Aggressive action on any surface. Performs well on buildup, grease, or tire marks.

High productivity stripping pad (Black) – For aggressive stripping of heavy finishes or sealers, or for very heavy duty scrubbing. *This pad can only be used with the grip pad driver, not the tufted pad driver.*

Stripping pad (Brown)– For stripping of floor finish to prepare the floor for recoating.

Scrubbing pad (Blue) – For medium to heavy-duty scrubbing. Removes dirt, spills, and scuffs.

Buffing pad (Red) – For light duty scrubbing without removing floor finish.

Polishing pad (White) – For maintaining highly polished or burnished floors.

WHILE OPERATING THE MACHINE

Pick up oversized debris before scrubbing. Pick up wire, string, twine, large pieces of wood, or any other debris that could become wrapped around or tangled in the brushes.

Operate the machine in a straight a path as possible. Avoid bumping into posts or scraping the sides of the machine. Overlap the scrub paths by several centimeters (a few inches).

Avoid turning too sharply when the machine is in motion. The machine is very responsive to sudden movement. Avoid sudden turns, except in emergencies.

Adjust the brush pressure and solution flow as required when scrubbing. Use the lowest brush pressure and solution flow settings for best performance.

If poor cleaning performance is observed, stop cleaning and refer to *MACHINE TROUBLESHOOTING* in this manual.

Operate the machine slowly on inclines. Scrub with the machine up inclines rather than down inclines.

FOR SAFETY: When using machine, go slowly on inclines and slippery surfaces.

Do not operate machine in areas where the ambient temperature is above 43° C (110° F). Do not operate scrubbing functions in areas where the ambient temperature is below freezing 0° C (32° F).

The maximum rated climb and descent incline with empty tanks is 14.1%, with full tanks is 10.5%.

PRE-OPERATION CHECKLIST

Check over this list of items before operating the machine:

- Check the battery charge level.

NOTE: The reading on the battery discharge indicator may not be accurate when the machine is first powered on. Operate the machine a few minutes before reading the charge level of the batteries.

- Check under the machine for leaks.
- Check for wire, string, or twine wrapped around the scrub brushes.
- Check the squeegees for wear or damage.
- Check the squeegee suction hose for obstructions.
- Check the recovery tank cover seals for wear or damage.
- Check that the vacuum fan inlet filter is clean.
- FaST Scrubbing:** Check the FaST PAK (option) concentrate agent level, replace carton as needed. See the INSTALLING THE FaST PAK AGENT section of the manual.
- FaST or ec-H₂O Scrubbing:** Check that all conventional cleaning agents/restorers are drained and rinsed from the solution tank.
- FaST or ec-H₂O Scrubbing:** Check that solution tank is filled with **clear cool water only**.
- Check maintenance records to determine maintenance requirements.

INSTALLING FaST PAK AGENT (OPTION)

FOR SAFETY: Before leaving or servicing machine, stop on level surface, set parking brake (if so equipped), turn off machine, and remove key.

NOTE: Machine must be equipped with the FaST option before the FaST PAK agent can be installed.

1. Remove the perforated knock-outs from the FaST PAK Floor Cleaning Concentrate carton. Do not remove the bag from the carton. Pull out the hose connector on the bottom of the bag and remove the hose cap from the connector.

NOTE: The FaST PAK Floor Cleaning Concentrate is specifically designed for use with the FaST system scrubbing application. NEVER use a substitute, machine damage will result.

FOR SAFETY: When using machine, always follow the handling instructions on chemical container.

2. Empty the solution tank. See the DRAINING AND CLEANING THE TANKS section of the manual.

NOTE: When scrubbing with the FaST system option, use clean water only. Do not add cleaning agents/restorers may cause failure to the FaST solution system.

3. Raise the solution tank and remove the front cover to access the FaST PAK carton.



OPERATION

- Place the FaST PAK carton in the carton holder under the front cover of the machine. Connect the supply hose to the FaST PAK bag.

NOTE: If any dried concentrate is visible on the supply hose connector or the on the FaST PAK connector, soak and clean with warm water.

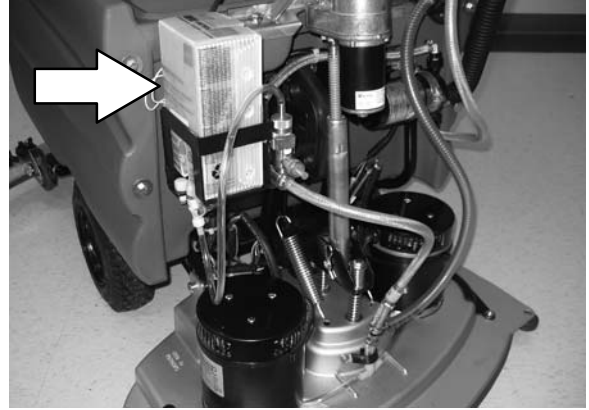

- Make sure to connect the supply hose onto the hose storing plug when the supply hose is not connected to the FaST PAK. This will prevent the FaST solution system from drying out and clogging up the hose.
- When replacing an empty FaST PAK carton, allow the new FaST PAK detergent to gravity feed into the system for several minutes prior to operating the FaST system. If the detergent does not flow out of the FaST PAK, simply squeeze and release the hose several times. If the previous FaST PAK was run dry, it may take up to 3 minutes of operation to remove any air pockets in the system before you achieve maximum foaming.

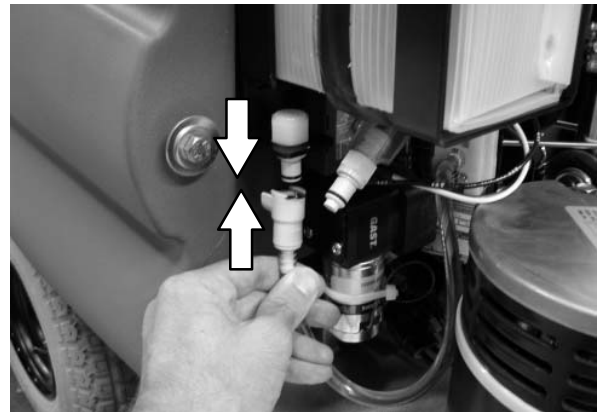

STARTING THE MACHINE

1. Turn the machine power on.



FILLING THE TANKS

1. Start the machine.
2. Drive the machine to the filling site.



3. Turn the machine power off.

FOR SAFETY: Before leaving or servicing machine, stop on level surface, set parking brake (if so equipped), turn off machine, and remove key.



OPERATION

4. CONVENTIONAL SCRUBBING: Open the solution tank cover and partially fill the solution tank with water. Pour the required amount of detergent into the solution tank fill opening. Continue filling the solution tank with water 25 mm (1 in) below the bottom of the solution fill opening channel.

FOR SAFETY: When using machine, follow mixing, handling and disposal instructions on chemical containers.

5. FaST or ec-H₂O SCRUBBING: Open the solution tank cover and fill the solution tank with clear cool water only.



NOTE: When cleaning using the FaST or ec-H₂O option, USE CLEAR COOL WATER ONLY. DO NOT add cleaning agents in solution tank. Conventional cleaning agents/restorers may cause failure to the system.

*NOTE: (For conventional scrubbing)
Floor conditions, water condition, amount of soilage, types of soilage, and brush action all play an important role in determining the type and concentration of detergent used. For specific recommendations, contact your Tennant representative.*

⚠ WARNING: Flammable materials can cause an explosion or fire. Do not use flammable materials in tank(s).

SCRUBBING

1. Start the machine.
2. Drive the machine to the area to be scrubbed.



3. Heavy Scrub Mode only: With the scrub head in the up position, pull out on the scrub head strap, until the scrub head drops into place.

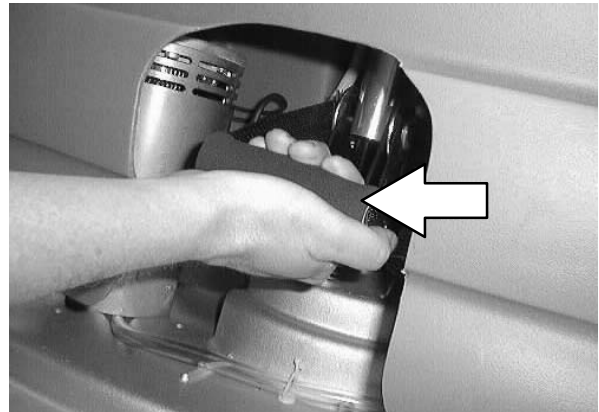

4. FaST SCRUBBING: Press the top of the FaST switch to start the FaST system.

NOTE: Leave the FaST switch in the CONVENTIONAL SCRUBBING position if not using the FaST system.

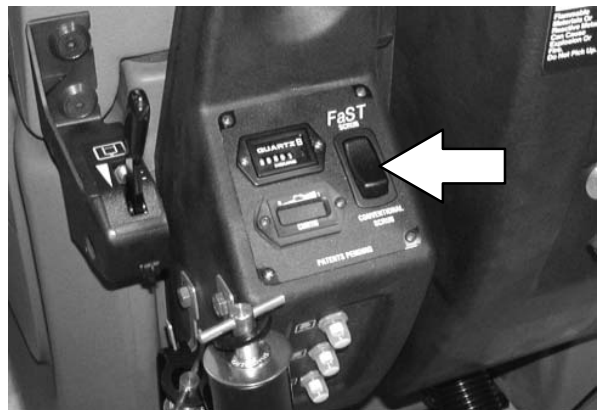

OPERATION

ec-H2O SCRUBBING: Press the top of the *ec-H2O* switch to start the *ec-H2O* system.

NOTE: Leave the *ec-H2O* switch in the **CONVENTIONAL SCRUBBING** position if not using the *ec-H2O* system.

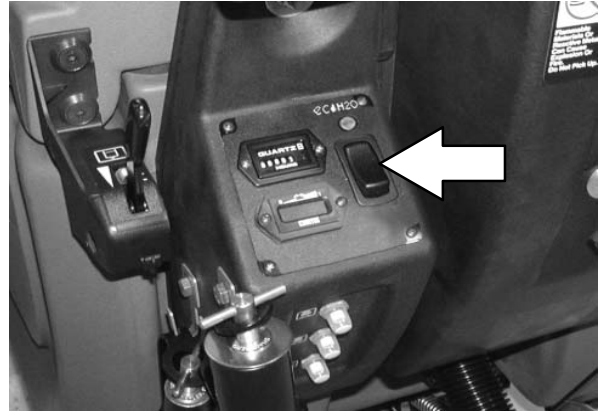

NOTE: The *ec-H2O* system indicator light will not turn on until the machine starts scrubbing.

ec-H2O SCRUBBING: If an alarm sounds and the *ec-H2O* system indicator light begins to blink red, the *ec-H2O* module must be flushed to resume *ec-H2O* operation (See *ec-H2O* MODULE FLUSH PROCEDURE)



NOTE: When the alarm sounds and the light blinks red, the machine will bypass the *ec-H2O* system. To continue scrubbing, turn the *ec-H2O* switch off and change over to conventional scrubbing.

ATTENTION: (*ec-H2O* model) Do not allow solution tank to run dry. *ec-H2O* module failure may result if operated without water for an extended period.

<i>ec-H2O</i> SYSTEM INDICATOR LIGHT CODE	CONDITION
Solid green	Normal operation
Blinking red	Flush <i>ec-H2O</i> module
Solid red	Contact Service Center

5. Press the top of the scrub switch to lower the scrub head and begin scrubbing.

FOR SAFETY: When using machine, go slowly on inclines and slippery surfaces.

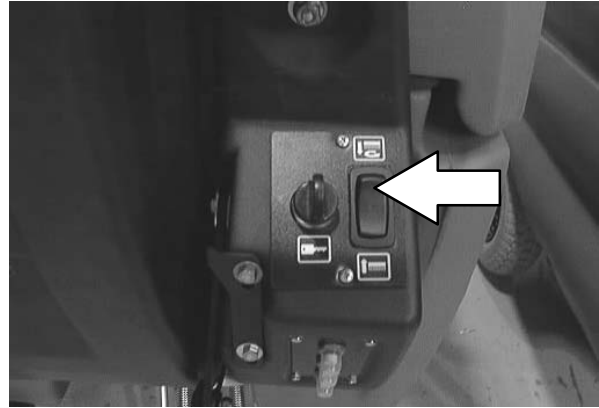

6. Lower the squeegee to the floor with the squeegee lever.

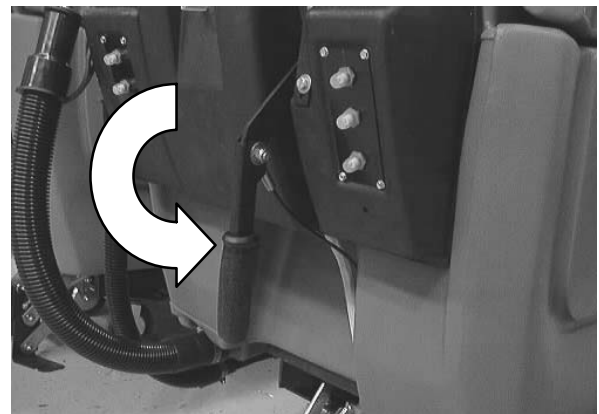

7. Adjust the solution flow to the floor as needed.

NOTE: When using the FaST or ec-H2O system (option), the solution flow lever is nonfunctional. The FaST and ec-H2O system flow rates are pre-set. The ec-H2O module has optional flow rate settings. If solution flow adjustments are required, contact an Authorized Service Center.



8. Drive the machine forward and scrub as required.

! WARNING: Flammable materials or reactive metals can cause an explosion or fire. Do not pickup.



DOUBLE SCRUBBING

Double scrubbing is a method for removing heavy floor accumulations. This is done by making two passes over the area to be cleaned with the machine.

Double scrubbing can be performed using the FaST SCRUBBING SYSTEM (option), ec-H₂O SCRUBBING SYSTEM (option) or CONVENTIONAL SCRUBBING methods.

1. First, make a pass over the area scrubbing with the squeegee up. This dispenses the solution/foam over the area allowing the solution/foam to soak on the floor.

NOTE: When using the FaST or ec-H₂O system (option), the solution flow lever is nonfunctional. The FaST and ec-H₂O system flow rates are pre-set. The ec-H₂O module has optional flow rate settings. If solution flow adjustments are required, contact an Authorized Service Center.

FOR SAFETY: When using machine, go slowly on inclines and slippery surfaces.

2. Lower the squeegee to the floor with the squeegee lever.

! WARNING: Flammable materials or reactive metals can cause an explosion or fire. Do not pickup.

3. Then make a second pass scrubbing with the squeegee down.

NOTE: Double scrubbing is not recommended in areas where the cleaning solution will run under racks or damage products.

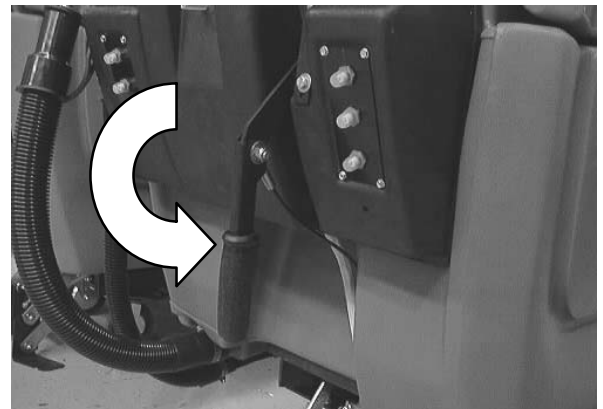
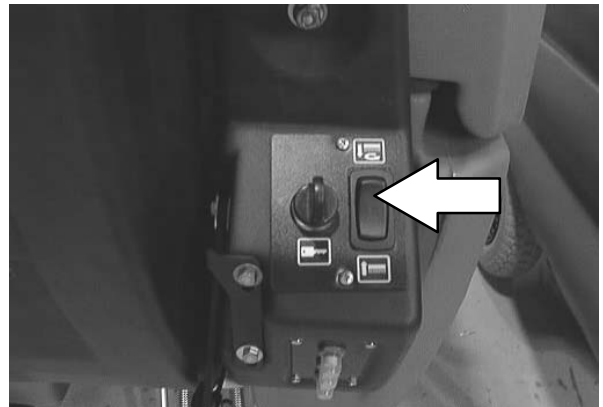

STOP SCRUBBING

1. Release the steering handles.



2. Press the bottom of the scrub switch to stop scrubbing and raise the scrub brushes.

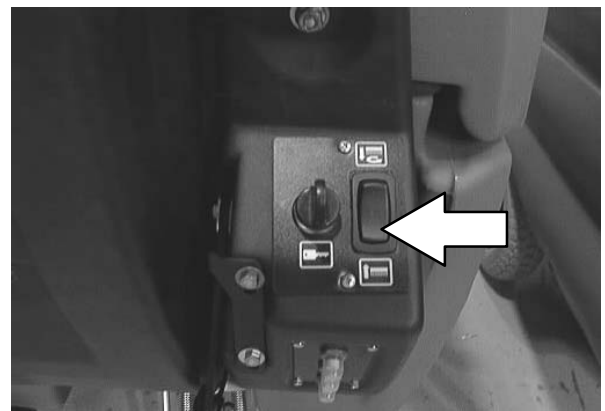

3. Propel the machine forward to pick up any solution left on the floor.

4. Raise the squeegee with the squeegee lever.

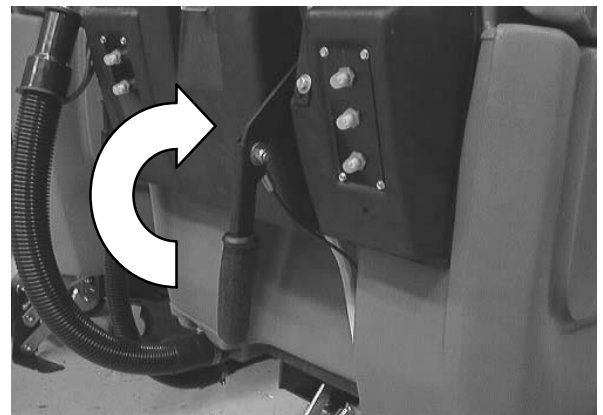

DRAINING AND CLEANING THE TANKS

RECOVERY TANK

When you are finished scrubbing, or when the vacuum fan shuts off, signalling a full recovery tank, the recovery tank should be drained and cleaned. The solution tank then can be filled again for additional scrubbing.

Clean the outside of the tank with vinyl cleaner.

1. Stop scrubbing.
2. Drive the machine next to a floor drain or sink.



3. Turn the machine power off.

FOR SAFETY: Before leaving or servicing machine, stop on level surface, set parking brake (if so equipped), turn off machine, and remove key.



4. Set the machine parking brake.

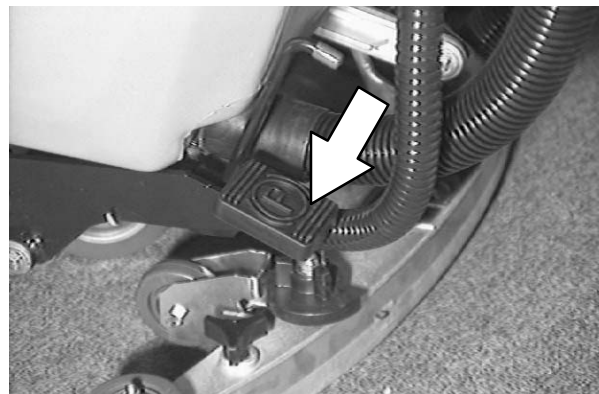

5. Check the solution tank, and empty any remaining solution with the solution tank drain hose.

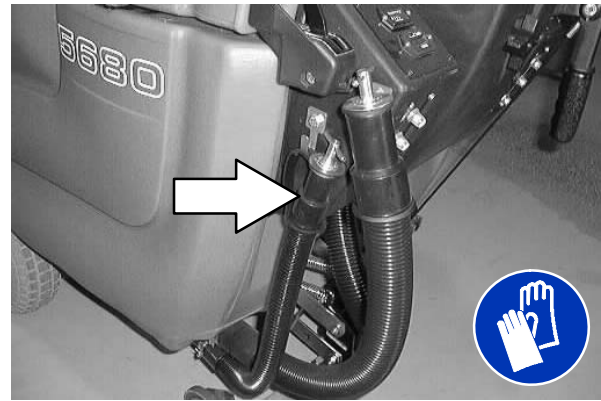

6. Lift the solution tank to reach the recovery tank.



7. Remove the recovery tank drain hose from the mounting clip.



8. Remove the recovery tank drain hose plug while holding the hose up, then slowly lower the drain hose to the floor drain or sink.



OPERATION

9. Flush out the inside of the recovery tank with clean water.

NOTE: DO NOT use steam to clean the tank. Excessive heat can damage the tanks and components.

10. If the machine is equipped with optional recovery tank debris screen, remove and clean it daily.



11. Rinse and wipe off the float sensor on the side of the recovery tank.

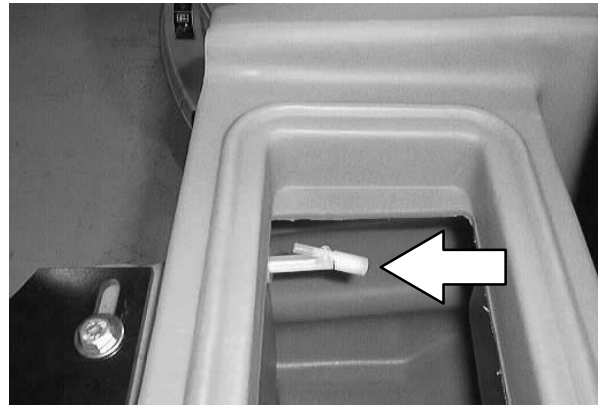

12. Remove and clean the vacuum fan filter located in the recovery tank. Clean by shaking dust or rinsing pleats with low pressure water. Insert the filter back in to the recovery tank when finished.

NOTE: Be sure the vacuum filter is dry before reinstalling it in the machine.



13. When the recovery and solution tanks have been completely drained, replace the drain hose plugs. Place the drain hoses back onto the mounting clips on the machine.



14. Pull up on the support arm and lower the solution tank. Push the stop arm in to completely lower the solution tank.



15. Cylindrical scrub head: Remove and clean the debris trough. Place the trough back in the scrub head.



OPERATION

SOLUTION TANK

FOR SAFETY: Before leaving or servicing machine, stop on level surface, set parking brake (if so equipped), turn off machine, and remove key.

The solution tank stores the cleaning solution. The solution tank does not require regular maintenance. If deposits form on the bottom of the tank, rinse the tank with a strong blast of warm water. The tank can be flushed through the fill opening and top access hole.

Clean the outside of the tank with vinyl cleaner.

1. Remove the solution tank drain hose from the mounting clip.

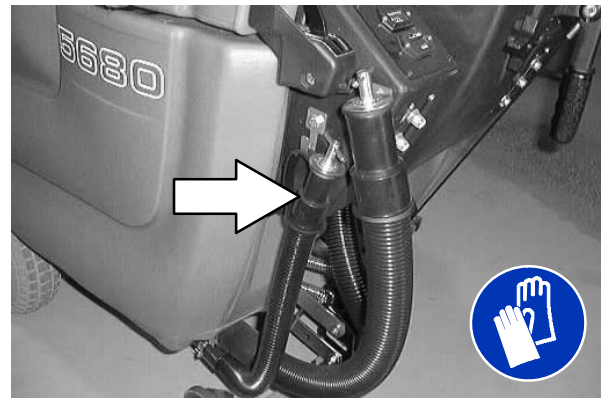

2. Remove the solution tank drain hose plug while holding the hose up, then slowly lower the drain hose to the floor drain or sink.



3. Rinse the tank with a strong blast of warm water. The tank can be flushed through the fill opening and top access hole.
4. When the solution tank has been completely drained, replace the drain hose plug. Place the drain hose back onto the mounting clip on the machine.



The solution tank contains one standard solution line filter. If the filter becomes dirty, the solution flow will be reduced. Check and clean these filters if necessary.

NOTE: DO NOT use steam to clean the tank. Excessive heat can damage the tanks and components.

STOP THE MACHINE

1. Stop scrubbing.
2. Turn the machine power off.

FOR SAFETY: Before leaving or servicing machine, stop on level surface, set parking brake (if so equipped), turn off machine, and remove key.

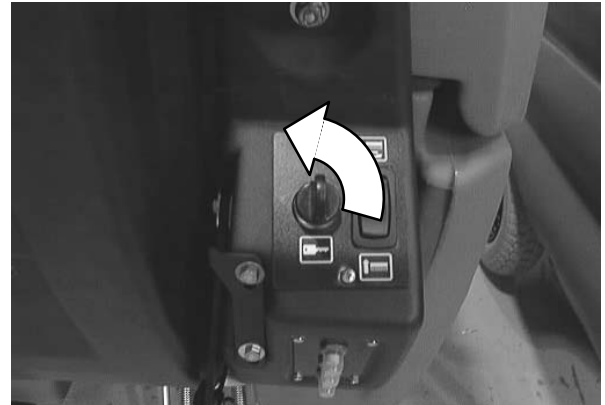

3. Set the machine parking brake.

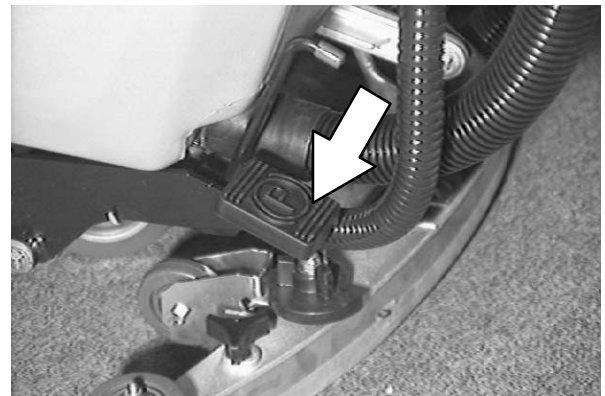

MACHINE TROUBLESHOOTING

Problem	Cause	Remedy	
Trailing water – poor or no water pickup	Worn squeegee blades	Rotate or replace squeegee blades	
	Squeegee out of adjustment	Adjust squeegee	
	Vacuum hose clogged	Flush vacuum hoses	
	Vacuum fan filter dirty	Clean inlet filter	
	Debris caught on squeegee	Remove debris	
	Vacuum hose to squeegee or recovery tank disconnected or damaged	Reconnect or replace vacuum hose	
	Solution tank not completely closed		Check for obstructions
			Heavy duty batteries posts too tall, file down posts
Machine front cover mounted too high, mount cover lower			
	Torn seals on solution tank	Replace seals	
Vacuum fan will not turn on	Recovery tank full	Drain recovery tank	
	Foam filling recovery tank	Empty recovery tank	
		Use less or change detergent	
		Use a defoamer	
	Recovery tank sensor dirty or stuck	Clean or replace	
	Vacuum fan circuit breaker tripped	Reset circuit breaker	
Little or no solution flow to the floor	Solution tank empty	Fill solution tank	
	Solution control cable broken or out of adjustment	Replace and/or adjust cable	
	Solution flow turned off	Turn solution flow on	
	Solution supply lines plugged	Flush solution supply lines	
	Solution supply line filter dirty	Clean filter	
	Solution solenoid clogged or stuck	Clean or replace	
Poor scrubbing performance	Debris caught on scrub brushes or pads	Remove debris	
	Improper detergent, brush, or pad used	Contact Service Center	
	Worn scrub brush(es) or pad(s)	Replace scrub brush(es) or pad(s)	
	Scrub brush motor circuit breaker(s) tripped		Reset circuit breaker(s)
			Reduce scrub brush down pressure
			Uneven brush pressure, level scrub head
			Contact Service Center
	Low battery charge	Charge batteries until the charger automatically turns off	

Problem	Cause	Remedy
Poor propelling traction	Tires slip on oily or waxed floors	Contact Service Center
	Uneven brush down pressure	Level scrub head
FaST System (option) does not operate	FaST switch is set for Conventional scrubbing	Set the FaST switch for FaST system scrubbing
	FaST circuit breaker tripped	Determine cause and reset the 10A circuit breaker button
	Clogged FaST PAK supply hose and/or connectors	Soak connector and hose in warm water and clean
	FaST PAK carton is empty or not connected	Replace FaST PAK carton and/or connect supply hose
	Clogged flow control orifice and/or screen	Remove and clean orifice and/or screen
	Faulty pump or air compressor	Contact Service Center
	Clogged filter screen	Drain solution tank, remove and clean filter screen
ec-H2O Model: ec-H2O system indicator light blinking red	Mineral deposit build-up in module	Flush module (See ec-H2O MODULE FLUSH PROCEDURE)
ec-H2O Model: ec-H2O system indicator light solid red	Defective module	Contact Service Center
ec-H2O Model: ec-H2O system indicator light does not turn on	Defective light or module	Contact Service Center
ec-H2O Model: No water flow	Clogged module	Contact Service Center
	Defective solution pump	Replace solution pump

MAINTENANCE

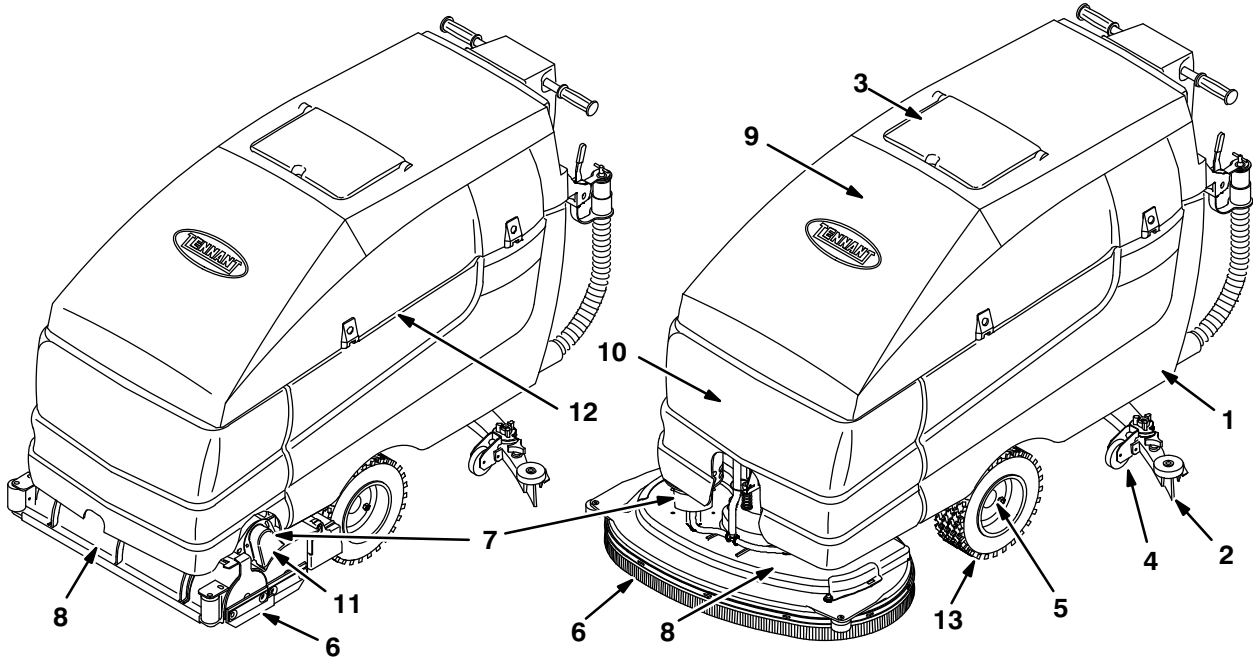

353417

MAINTENANCE CHART

The table below indicates the *Person Responsible* for each procedure.

O = Operator.

T = Trained Personnel.

Interval	Person Resp.	Key	Description	Procedure	Lubricant/ Fluid	No. of Service Points
Daily	O	2	Squeegee	Check for damage and wear	–	1
				Check deflection and leveling	–	1
	O	8	Scrub brushes or pads	Check for damage and wear	–	2
	O	1	Recovery tank	Clean tank	–	1
				Clean float sensor	–	1
				Clean vacuum fan filter	–	1
				Clean debris screen (option)	–	1
	O	3	Solution tank	Clean	–	1
	O	3	Vacuum fan filter	Clean	–	1
	O		Machine	Check for leaks	–	1
	O	6	Disk scrub head skirt	Check for damage and wear	–	1
	O	6	Cylindrical scrub head skirts	Check adjustment	–	4
Check for damage and wear				–	4	
O	10	FaST PAK supply hose and connector (option)	Clean and connect hose to storing plug when not in use	–	1	
Weekly	T	12	Battery cells	Check electrolyte level	DW	Multiple
50 Hours	O	10	FaST Filter screen (option)	Clean	–	1
	T	8	Cylindrical brushes	Check taper and rotate front to rear	–	2

The table below indicates the *Person Responsible* for each procedure.

O = Operator.

T = Trained Personnel.

Interval	Person Resp.	Key	Description	Procedure	Lubricant/ Fluid	No. of Service Points
100 Hours	T	4	Rear casters	Lubricate	SPL	2
	T	11	Cylindrical scrub brush drive belts	Check tension	–	2
200 Hours	T	12	Battery terminals and cables	Check and clean	–	Multiple
500 Hours	T	10	Vacuum fan motor	Check motor brushes	–	1
	O	13	Tires	Check for damage and wear	–	2
1000 Hours	T	10	FaST water and air filters (option)	Replace	–	1
	T	7	Scrub brush motors	Check motor brushes	–	2
	T	5	Propelling motor	Check motor brushes	–	1
	T	5	Transaxle	Check lubricant level	GL	1

LUBRICANT/FLUID

DW . . . Distilled water.

SPL – Special lubricant, Lubriplate EMB grease (TENNANT part no. 01433–1)

GL – SAE 90 weight gear lubricant

NOTE: More frequent maintenance intervals may be required in extremely dusty conditions.

LUBRICATION

FOR SAFETY: Before leaving or servicing machine, stop on level surface, set parking brake (if so equipped), turn off machine, and remove key.

REAR CASTERS

The rear casters each have one grease fitting on the caster swivel. Lubricate the caster with a grease gun containing Lubriplate EMB grease (TENNANT part no. 01433-1) every 100 hours of machine operation.

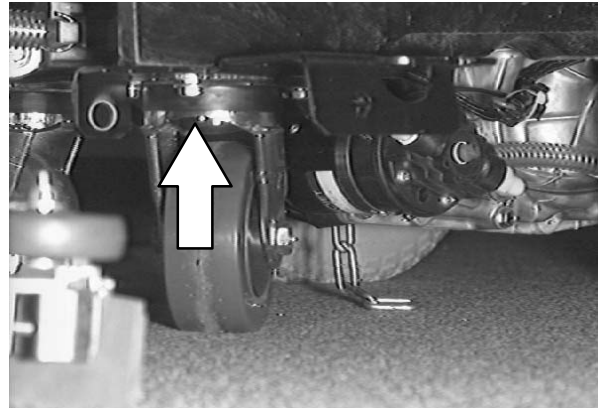

TRANSAXLE

Check the transaxle lubricant level every 1000 hours of operation by removing one of the orange filler plugs. If needed, add SAE 90 weight gear lubricant.

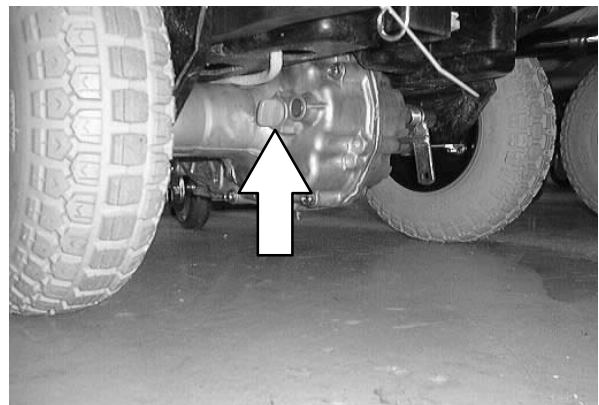

BATTERIES

The lifetime of the batteries is limited to the number of charges the batteries receive. To get the most life from the batteries, only recharge the batteries when the battery discharge indicator is down to the last bar. It is also important to maintain the proper electrolyte levels during the life of the battery.

CHECKING THE ELECTROLYTE LEVEL (WET / LEAD ACID BATTERIES ONLY)

Check the battery electrolyte level weekly for machines equipped with wet/lead acid batteries.

FOR SAFETY: When servicing machine, avoid contact with battery acid.

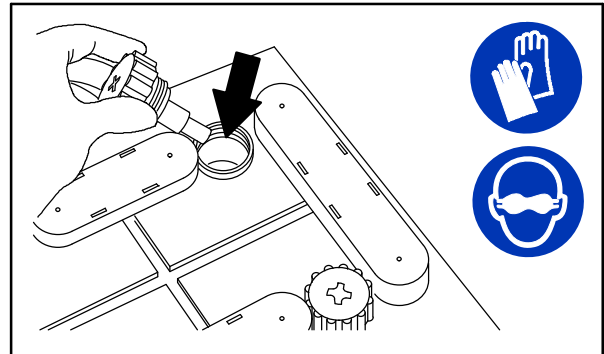

08247

The level should be slightly above the battery plates as shown before charging. Add distilled water if low. **DO NOT OVERFILL.** The electrolyte will expand and may overflow when charging.

NOTE: Make sure the battery caps are in place while charging.

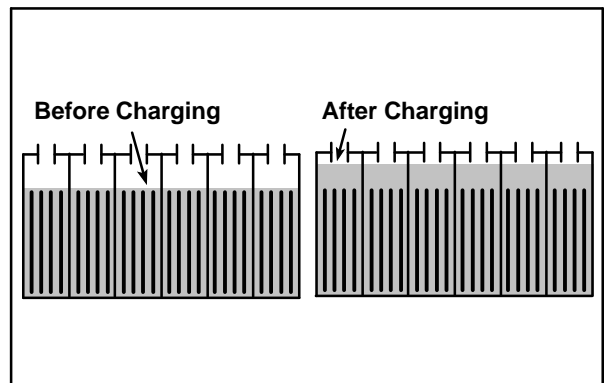

CHECKING CONNECTIONS / CLEANING

After every 200 hours of use check for loose battery connections and clean the surface of the batteries, including terminals and cable clamps, with a strong solution of baking soda and water. Replace any worn or damaged wires. Do not remove battery caps when cleaning batteries.

Objects made of metal can potentially short circuit the batteries. Keep all metallic objects off the batteries.



CHARGING THE BATTERIES

FOR SAFETY: When servicing machine, the use of incompatible battery chargers may damage battery packs and potentially cause a fire hazard. Inspect charger cord regularly for damage.

1. Drive the machine to a flat, dry surface in a well-ventilated area.
2. Turn the machine power off and set the parking brake if your machine has this option.

FOR SAFETY: Before leaving or servicing machine, stop on level surface, set parking brake (if so equipped), turn off machine, and remove key.

3. Lift up the solution tank to get access to the batteries.

NOTE: The solution tank must be empty.



NOTE: Make sure the batteries have the proper electrolyte level before charging. See CHECKING THE ELECTROLYTE LEVEL.

4. Plug the charger connector into the battery connector.

! WARNING: Batteries emit hydrogen gas. Explosion or fire can result. Keep sparks and open flame away. Keep covers open when charging.

5. Plug the battery charger into the wall outlet.

NOTE: If the red "ABNORMAL CYCLE" lamp lights when the TENNANT charger is plugged into a wall outlet, the charger cannot charge the battery and there is something wrong with the battery.

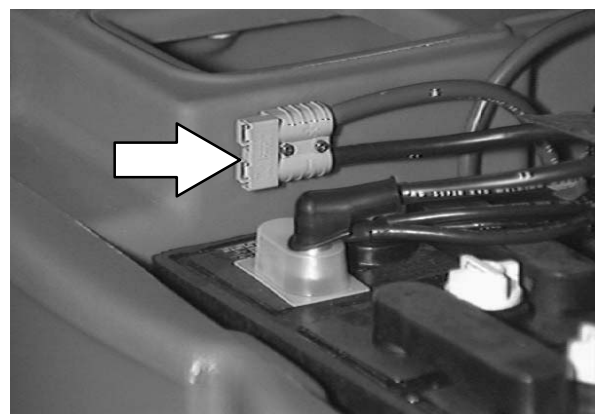

6. The TENNANT charger will start automatically. When the batteries are fully charged, the TENNANT charger will automatically turn off.

- After the charger has turned off, unplug the charger from the wall outlet.

FOR SAFETY: When servicing machine, do not disconnect the charger DC cord from the machine receptacle when the charger is operating. Arcing may result. If the charger must be interrupted during charging, disconnect the AC power supply cord first.

- Unplug the charger connector from the battery connector on the machine.
- Lower the solution tank.
- Pull up on the support arm and rotate the stop arm out of the way to allow the solution tank to close completely.

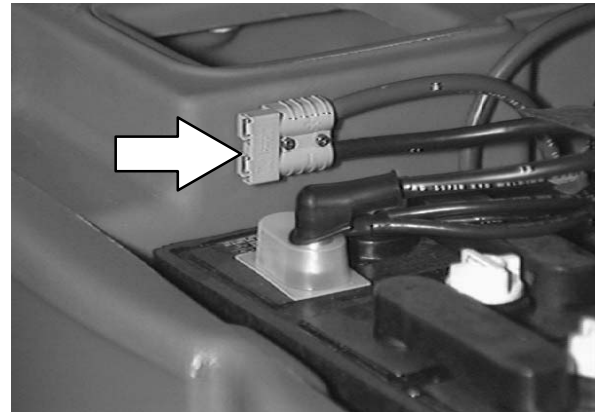

CIRCUIT BREAKERS

The circuit breakers are resettable electrical circuit protection devices. They stop the flow of current in the event of a circuit overload. Once a circuit breaker is tripped, reset manually by pressing the reset button after the breaker has cooled down.

If the overload that caused the circuit breaker to trip is still there, the circuit breaker will continue to stop current flow until the problem is corrected.

The circuit breakers are located on each side of the operator console.

The chart shows the circuit breakers and the electrical components they protect.

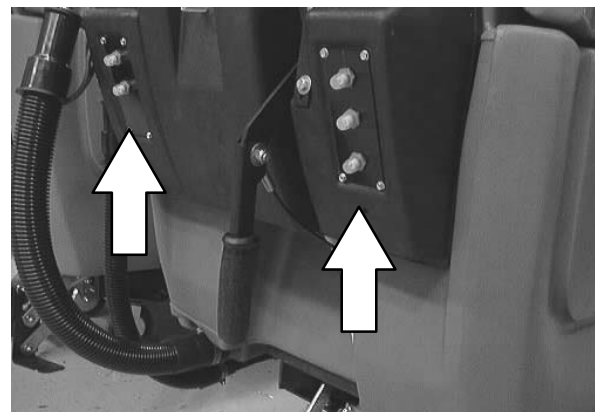

Circuit Breaker	Rating	Circuit Protected
CB1	10 A	Machine power
CB2	25 A	Vacuum fan motor
CB3	25 A	Machine propel
CB4	30 A	Right brush motor
CB5	30 A	Left brush motor
CB6	10 A	FaST (option)
	10 A	ec-H2O (option)

ELECTRIC MOTORS

FOR SAFETY: Before leaving or servicing machine, stop on level surface, set parking brake (if so equipped), turn off machine, and remove key.

The carbon brushes on the vacuum fan motor should be inspected after every 500 hours of machine operation. The carbon brushes on the scrub brush motors and propelling motor should be inspected after every 1000 hours of machine operation.

SCRUB HEAD

The machine is equipped with a disk brush scrub head. The scrub head contains skirts to control over-spray from the scrub brushes.

DISK BRUSH SCRUB HEAD SKIRT

Make sure the scrub head skirt touches the floor all the way around when the scrub head is lowered. Check the skirt for damage or wear daily.

NOTE: Replace the scrub head skirt when it is damaged or no longer is able to touch the floor.

CYLINDRICAL BRUSH SCRUB HEAD SKIRTS

The four head skirts should just touch the floor. Check the skirts for damage or wear daily.

ADJUSTING THE SCRUB HEAD SKIRTS

1. Lower the scrub head on a level floor.
2. Turn the machine power off.

FOR SAFETY: Before leaving or servicing machine, stop on level surface, set parking brake (if so equipped), turn off machine, and remove key.

3. Check to see if the scrub head skirts touch the floor.
4. If any of the skirts needs adjusting, loosen the retainer strip hardware and slide the skirt to the proper adjustment. Tighten the retainer strip hardware.

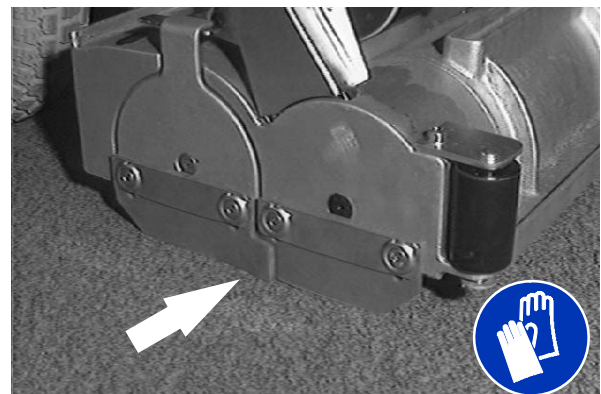

REPLACING THE SCRUB HEAD SKIRTS

1. Raise the scrub head.
2. Turn the machine power off.

FOR SAFETY: Before leaving or servicing machine, stop on level surface, set parking brake (if so equipped), turn off machine, and remove key.

3. Remove the retainer strip and hardware.
4. Replace the old skirt with a new skirt and mount in place with the retainer strip and hardware.

MAINTENANCE

REMOVING OR REPLACING THE SCRUB HEAD

The scrub heads are available in three widths.

NOTE: When you change to a different width scrub head, be sure to install the appropriate width squeegee and machine front cover.

1. Lower the scrub head.
2. Turn the machine power off.

FOR SAFETY: Before leaving or servicing machine, stop on level surface, set parking brake (if so equipped), turn off machine, and remove key.

3. Remove the machine front cover.



4. Disconnect the solution line from the scrub head tee fitting.



5. Disconnect the wire harness from each scrub motor.



6. Disconnect the scrub head from the guide by removing the clevis pin.

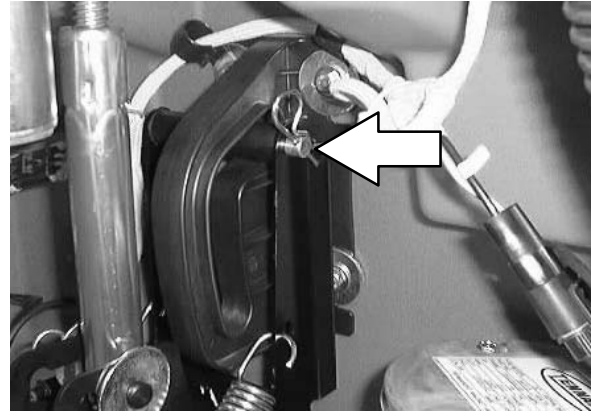

7. Disconnect the lift arms from the scrub head by removing the two clevis pins.

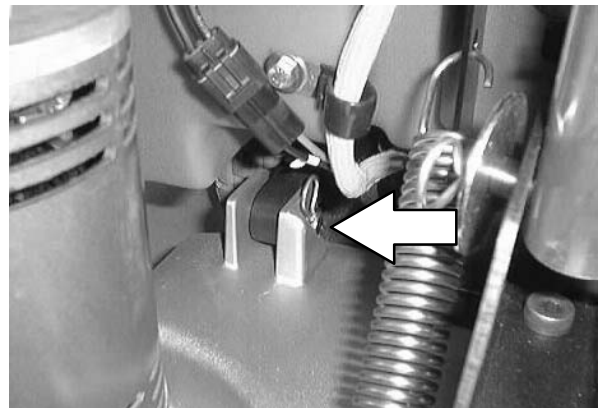

8. Mark the location of the actuator tube on the actuator shaft before disconnecting the actuator. Disconnect the actuator from the scrub head by removing the clevis pin.

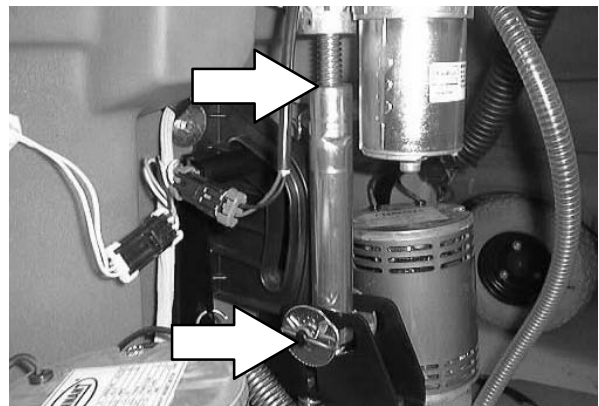

9. To install the scrub head, connect the lift arms to the scrub head with the two clevis pins.
10. Connect the scrub head to the guide with the clevis pin.
11. Make sure the actuator tube lines up with the mark made earlier on the actuator shaft. If not, turn the actuator tube until it does. Connect the actuator to the scrub head with the clevis pin.
12. Connect the wire harness.
13. Connect the solution line to the scrub head tee fitting.

LEVELING THE SCRUB HEAD

1. Make sure the scrub head is lowered to the floor.

FOR SAFETY: Before leaving or servicing machine, stop on level surface, set parking brake (if so equipped), turn off machine, and remove key.

2. Check the level of the scrub head by measuring the distance from the top of the scrub head, to the floor at all four corners. The scrub head should measure the same on all four corners.

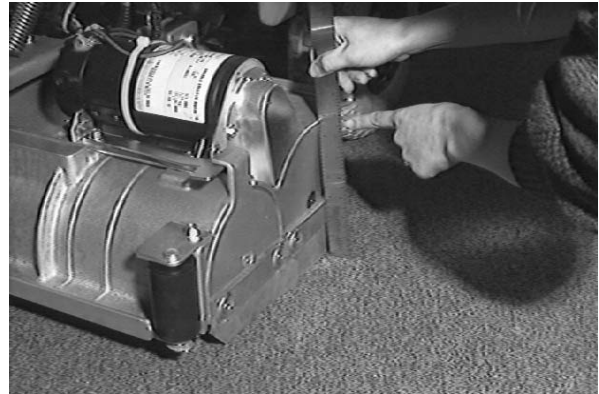

3. If the scrub head is not level at all four corners, loosen the jam nut on the adjustment screw located on the top of the scrub head. Turn the adjustment screw until the scrub head measures level. Tighten the jam nut.
4. Install the machine front cover.
5. Cylindrical scrub head: Check the brush pattern as described in *CHECKING AND ADJUSTING CYLINDRICAL BRUSH PATTERN*.

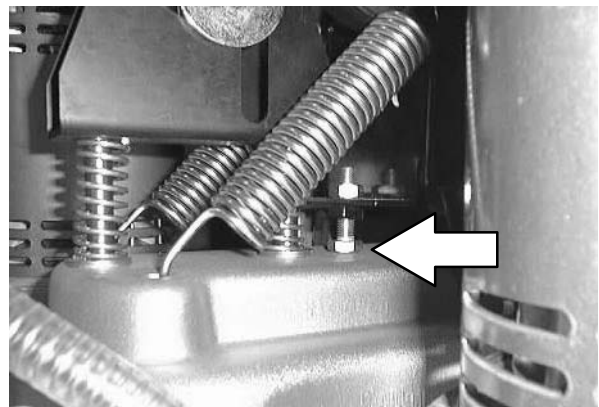

SCRUB BRUSHES AND PADS

The scrub brushes should be checked daily for wire or string tangled around the brush or drive hub. The brushes should also be checked for any damage and wear.

DISK BRUSHES

Replace the brushes or pads when they no longer clean effectively.

Cleaning pads must be placed on pad drives before they are ready to use. The cleaning pad is held in place by a pad holder.

Cleaning pads need to be cleaned immediately after using with soap and water. Do not wash the pads with a pressure washer. Hang dry pads, or lie flat to dry.

NOTE: Be sure to replace brushes and pads in sets. Otherwise one brush or pad will be more aggressive than the other.

REPLACING THE DISK BRUSHES OR PADS

1. Raise the scrub head.
2. Turn the machine power off.

FOR SAFETY: Before leaving or servicing machine, stop on level surface, set parking brake (if so equipped), turn off machine, and remove key.

3. Open the access cover on either corner of the scrub head.



MAINTENANCE

4. Turn the brush/pad driver until you can see the brush spring clip.

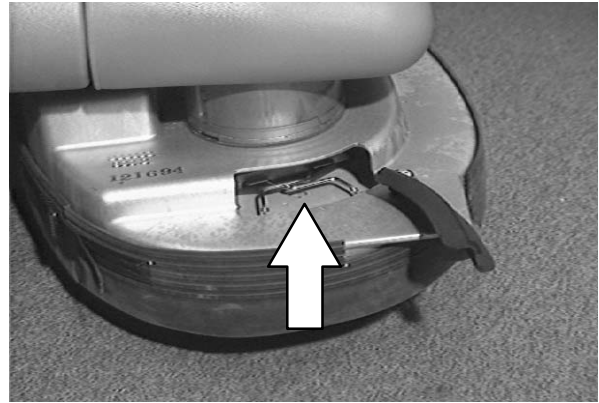

5. Press the spring clip together with your thumb and index finger. The brush/pad driver will drop off the drive hub.



6. Pull the brush/pad driver out from under the scrub head.



7. PAD DRIVER ONLY: Turn the pad driver over to access the spring clip underneath.
8. Press the spring clip together with your thumb and index finger to remove the center disk.



9. Flip or replace the scrub pad, center the scrub pad on the pad driver.

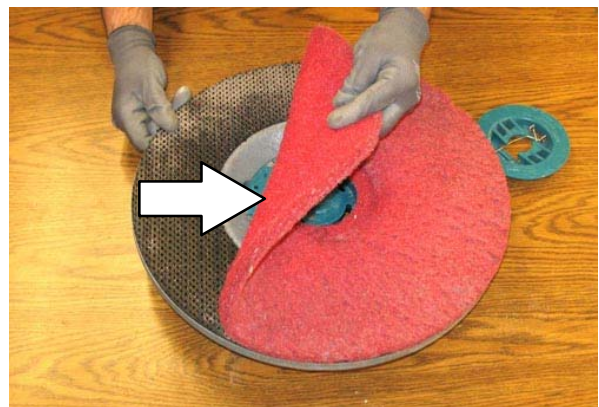

10. Replace the center disk to secure the pad in place on the driver.



MAINTENANCE

11. Place the new scrub brush/pad driver on the floor in front of the scrub head. Push the brush under the scrub head.
12. Line up the drive socket with the drive plug.
13. Lift the scrub brush/pad driver assembly into the drive plug.
14. Check to make sure the brush/pad driver assembly is securely mounted on the brush drive hub.
15. Close the scrub head access cover.
16. Repeat for the other brush/pad driver.



CYLINDRICAL BRUSHES

Check the brush taper and rotate the brushes from front-to-rear every 50 hours of operation, for maximum brush life and best scrubbing performance.

Replace the brushes or pads when they no longer clean effectively.

NOTE: Be sure to replace brushes in sets. Otherwise one brush will be more aggressive than the other.

REPLACING THE CYLINDRICAL BRUSHES

1. Raise the scrub head.
2. Turn the machine power off and set the parking brake if your machine has this option.

FOR SAFETY: Before leaving or servicing machine, stop on level surface, set parking brake (if so equipped), turn off machine, and remove key.

3. Push down on the mounting spring and the idler door, then pull out on the bottom of the door. Push down on the spring until the door releases from the scrub head. Pull the idle plug off the brush.



4. Pull the brush out of the scrub head.
5. With the double row end of the brush towards you, guide the brush onto the drive hub.

NOTE: Use the double rows on the idler end of the brush.



MAINTENANCE

NOTE: Cylindrical scrub brushes must be installed with the herringbone patterns on the brushes pointing towards each other for best debris pick up.

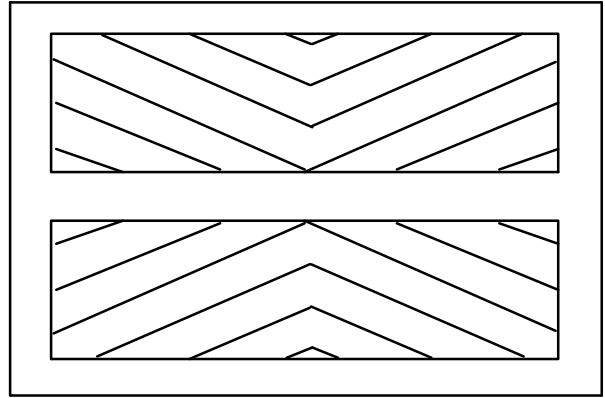

6. Insert the Idler plug of the idler door into the brush.



7. Push down on the door to catch the door in the scrub head, then pull up on the door to latch it in the spring.
8. Repeat for the other brush on the other side of the scrub head.

NOTE: The idler doors have stamped letters that correspond with letters on the scrub head. Make sure the idler doors are placed back on the same side of the scrub head that they were originally removed from.



CHECKING AND ADJUSTING CYLINDRICAL BRUSH PATTERN

NOTE: Check the tires for correct tire pressure and make sure the solution tank is full before checking or adjusting the brush pattern.

1. Apply chalk, or some other material that will not blow easily away, to a smooth, level floor.
2. Raise the scrub head. Position the scrub head over the chalked area.
3. Set the parking brake if your machine has this option.
4. Lower the scrub head for 15 to 20 seconds while keeping the scrub head in one spot in the chalked area.

NOTE: If chalk or other material is not available, allow the brushes to spin on the floor for two minutes. A polish mark will remain on the floor.

5. Raise the scrub head and move the machine away from the chalked area. Turn the machine power off.

FOR SAFETY: Before leaving or servicing machine, stop on level surface, set parking brake (if so equipped), turn off machine, and remove key.

6. Observe the shape of the brush patterns. If the brush patterns have parallel sides, the brushes do not need taper adjustment.

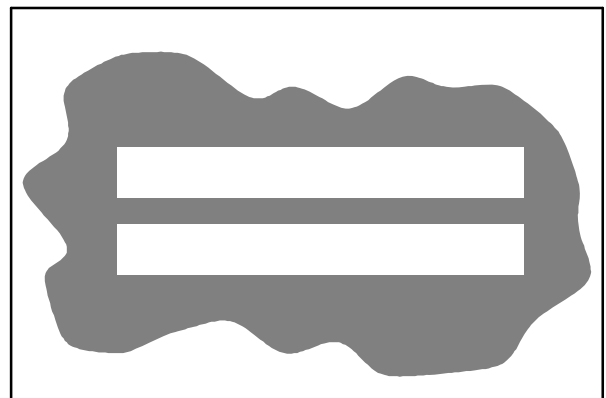

10355

If one or both of the brush patterns are tapered, the brushes will have to be adjusted to straighten the brush pattern.

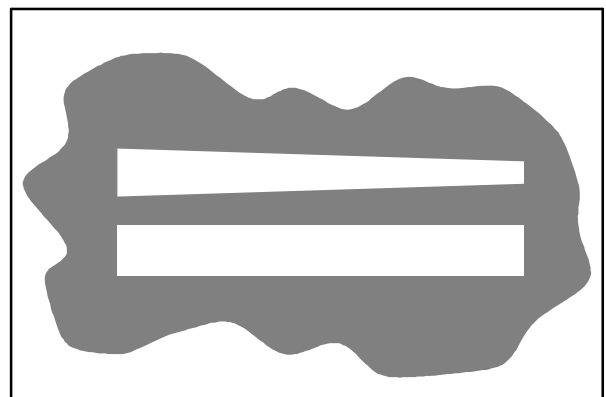

10356

MAINTENANCE

- A. Remove the idler door by pushing down on the mounting spring and the idler door, then pulling out on the bottom of the door. Push down on the spring until the door releases from the scrub head. Pull the idle plug off the brush.



- B. While holding the flat end of the idler shaft with a wrench, loosen the mounting screw on the outside of the idler door.



- C. Turn the idler shaft to raise or lower the end of the brush as needed to straighten the brush pattern. Tighten the mounting screw.

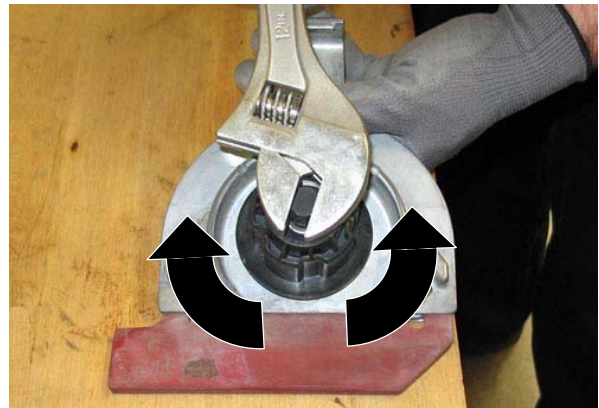

- D. Check the brush patterns again and readjust as necessary.

The brush patterns should be the same width. If one is narrower than the other, loosen the jam nut on the adjustment screw located on the top of the scrub head.

Turn the adjustment screw clockwise to increase the front brush pattern width. Turn the adjustment screw counter-clockwise to increase the back brush pattern width. Check the brush patterns again. Adjust until the front and back patterns are the same width.

Tighten the jam nut.

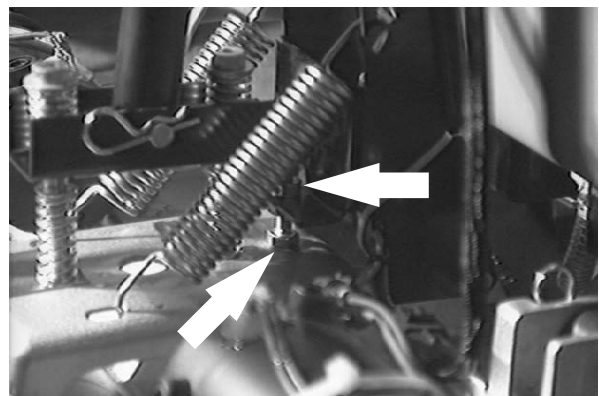

FaST SYSTEM (OPTION)

FaST SYSTEM MAINTENANCE

FOR SAFETY: Before leaving or servicing machine, stop on level surface, set parking brake (if so equipped), turn off machine, and remove key.

Every 1000 hours replace the water filter and air filter located in the FaST detergent injector. Order filter kit p/n 9003009.

To access the detergent injector assembly, lower the scrub head and remove the front cover.

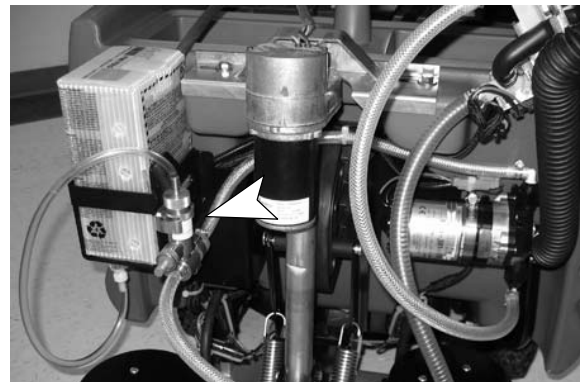

Remove the injector assembly from clamps.



Replace the water and air filter. An 8mm hex wrench required to install new water filter.

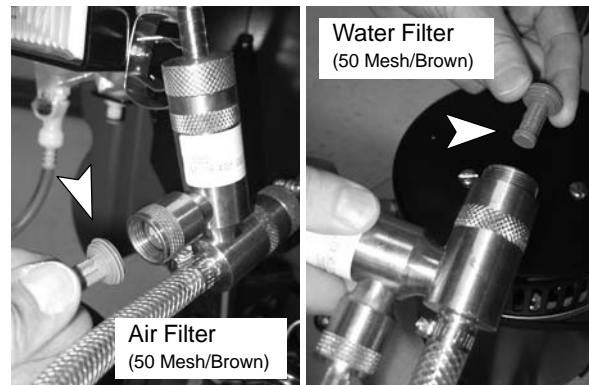

FaST SYSTEM FILTER SCREEN

FOR SAFETY: Before leaving or servicing machine, stop on level surface, set parking brake (if so equipped), turn off machine, and remove key.

The FaST system filter screen is located under the solution tank and filters the water from the solution tank as it flows into the FaST system.

Remove the filter screen bowl and clean the filter screen after every 50 hours of machine operation. Empty the solution tank before removing the filter.



FaST SUPPLY HOSE CONNECTOR

FOR SAFETY: Before leaving or servicing machine, stop on level surface, set parking brake (if so equipped), turn off machine, and remove key.

The FaST supply hose connector is located below the FaST PAK holder. Soak the connector in warm water if detergent buildup is visible. When a FaST PAK carton is not installed, store the supply hose connector on the storing plug to prevent the hose from clogging.



ec-H2O SYSTEM (OPTION)

ec-H2O MODULE FLUSH PROCEDURE

This procedure is only required when an alarm sounds and the *ec-H2O* system indicator light begins to blink red.

FOR SAFETY: Before leaving or servicing machine, stop on level surface, set parking brake (if so equipped), and turn off machine.

1. Drain the solution tank and recovery tank of all water.
2. Pour 2 gallons (8 liters) of white or rice vinegar into the solution tank at full strength. Do not dilute.
(p/n 1050552 – Vinegar, 2.5 gals/10 ltrs)

NOTE: Use **white or rice vinegar** only. The acidity level should be between 4–8%. Do not use other acids for this procedure.

3. Disconnect the black connector fitting at the scrub head and place the hose into a bucket. To access the connector fitting, you may have to remove the front cover from the machine.
4. Turn the key to the on position.

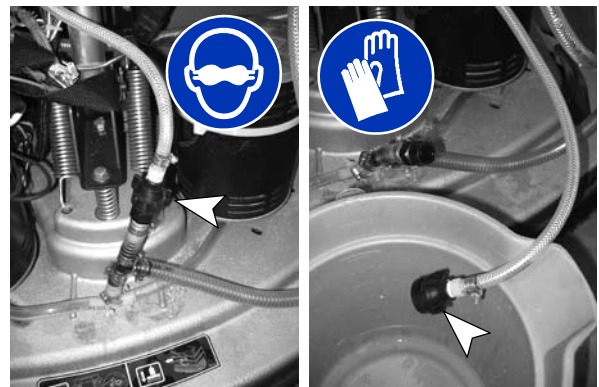

5. Press and release the *ec-H2O* module flush switch to start the flush cycle. The module is located behind the front cover.

NOTE: The module will automatically shut off when the flush cycle is complete (approx. 7 minutes). The module must run the full 7 minute cycle in order to reset the system indicator light and alarm.

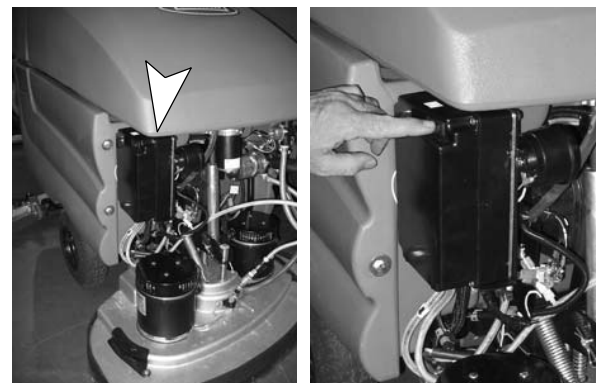

Repeat flush procedure if the *ec-H2O* module does not reset. If module fails to reset, contact an Authorized Service Center.

SQUEEGEE

The squeegee assembly channels water into the vacuum fan suction. The front blade channels the water, and the rear blade wipes the floor.

Check the squeegee blades for damage and wear daily. Rotate or replace either of the squeegee blades if the leading edge is torn or worn half-way through the thickness of the blade.

The squeegee can be adjusted for leveling and deflection. The deflection and leveling of the squeegee blades should be checked daily, or when scrubbing a different type of floor.

The squeegee assembly can be removed from the squeegee pivot to prevent damage during transport of the machine, or when changing to a different squeegee width. The squeegees are available in three widths to be used with the three different model scrub heads; model 700 (700 mm), model 800 (800 mm), and model 900 (900 mm).

REMOVING THE SQUEEGEE ASSEMBLY

1. Raise the squeegee.
2. Turn the machine power off.

FOR SAFETY: Before leaving or servicing machine, stop on level surface, set parking brake (if so equipped), turn off machine, and remove key.

3. Remove the squeegee suction hose from the squeegee.

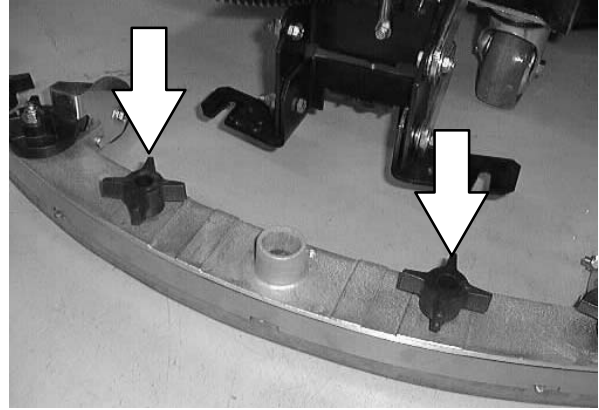

4. Loosen the two mounting knobs.
5. Pull the squeegee off the machine.

**INSTALLING THE SQUEEGEE ASSEMBLY**

1. Make sure the squeegee is raised.
FOR SAFETY: Before leaving or servicing machine, stop on level surface, set parking brake (if so equipped), turn off machine, and remove key.
2. Place the squeegee under the squeegee pivot.
3. Slide the squeegee frame onto the squeegee pivot.
4. Tighten the mounting knobs.
5. Push the squeegee suction hose on the squeegee.

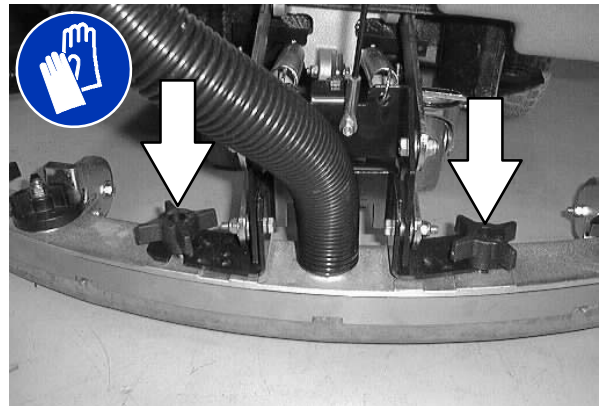

LEVELING THE SQUEEGEE

Leveling of the squeegee assures even contact the length of the squeegee blade with the surface being scrubbed. Make sure this adjustment is done on an even, level floor.

1. Turn the machine power on.
2. Lower the squeegee.
3. Drive the machine forward, then turn the machine power off.

FOR SAFETY: Before leaving or servicing machine, stop on level surface, set parking brake (if so equipped), turn off machine, and remove key.

4. Look at the deflection of the squeegee blade, over the full length of the squeegee blade.

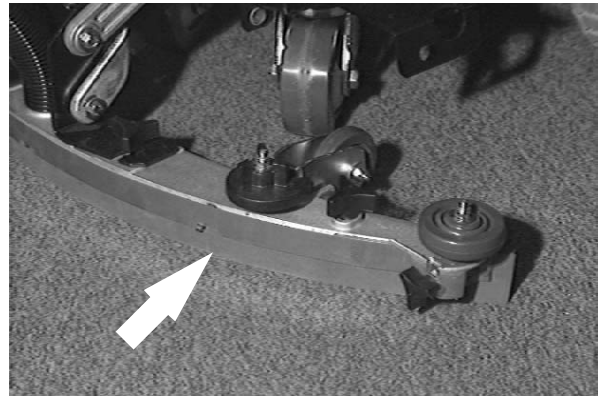

5. If the deflection is not the same over the full length of the blade, turn the squeegee leveling bolt counter-clockwise to increase the deflection at the ends of the squeegee.

Turn the squeegee leveling bolt clockwise to decrease the deflection at the ends of the squeegee blade.

6. Drive the machine forward again with the squeegee down to check the squeegee blade deflection.
7. Readjust the squeegee blade deflection if necessary.

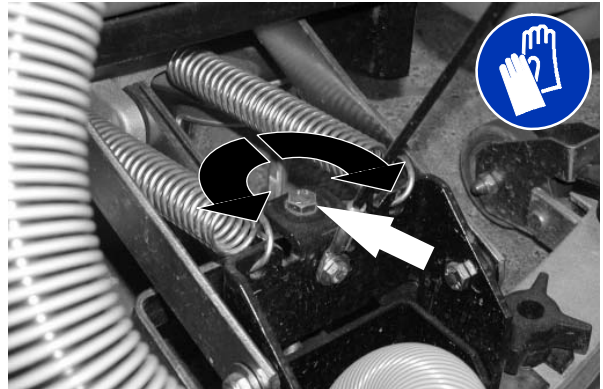

ADJUSTING SQUEEGEE BLADE DEFLECTION

Deflection is the amount of curl the squeegee blade has when the machine moves forward with the squeegee lowered to the floor. The best deflection is when the squeegee wipes the floor just dry with a minimum amount of deflection.

1. Turn the machine power on.
2. Lower the squeegee.
3. Drive the machine forward, and look at the deflection of the squeegee blade. The correct amount of deflection is 12 mm for scrubbing smooth floors and 15 mm for rough floors.

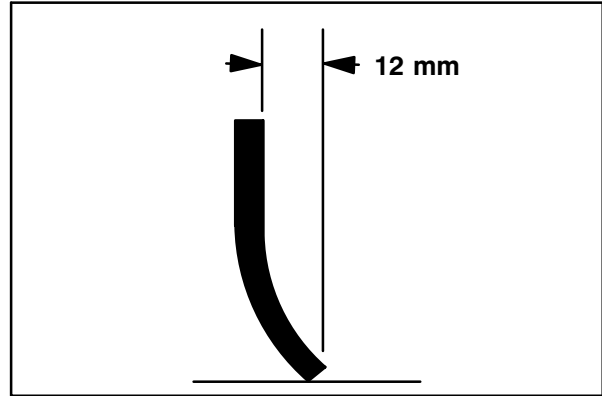

03719

4. Turn the machine power off.

FOR SAFETY: Before leaving or servicing machine, stop on level surface, set parking brake (if so equipped), turn off machine, and remove key.

5. To adjust the amount of deflection, turn the squeegee deflection cams counter-clockwise to decrease the blade deflection.

Turn the squeegee deflection cams clockwise to increase blade deflection.

6. Drive the machine forward again to check the squeegee blade deflection.
7. Readjust the squeegee blade deflection if necessary.

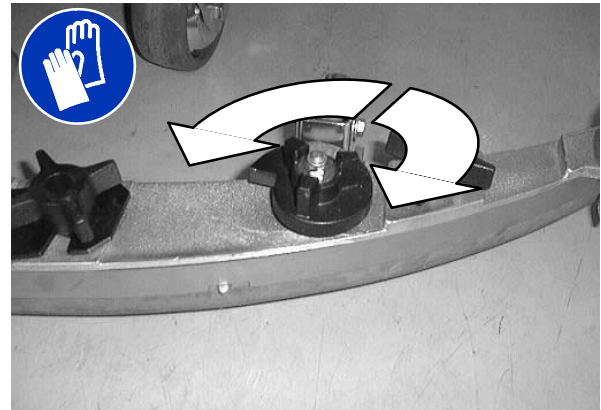

SQUEEGEE BLADES

The squeegee has two squeegee blades, the front and back. Each blade has four wiping edges. To use them all, start with one wiping edge. To use the next wiping edge, rotate the blade end-for-end. To use the next wiping edge, rotate the top edges down, bottom edges up. To use the last edge, rotate the blade end-for-end.

Replace any worn or damaged squeegee blades.

REPLACING OR ROTATING THE REAR SQUEEGEE BLADE

1. Make sure the squeegee is raised off the floor.
2. Turn the machine power off.

FOR SAFETY: Before leaving or servicing machine, stop on level surface, set parking brake (if so equipped), turn off machine, and remove key.

3. Loosen the two retention knobs, one at each end on the squeegee.

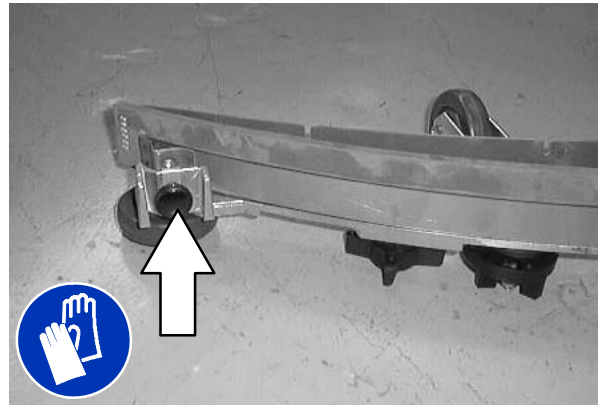

4. Pull off the rear retaining band.



5. Pull off the rear squeegee blade.
6. Insert the rotated or new squeegee blade and then insert the retainer band.
7. Tighten the two retention knobs until the ends of the front and rear squeegee blades touch. Do not over tighten.



REPLACING OR ROTATING THE FRONT SQUEEGEE BLADE

1. Make sure the squeegee is raised off the floor.
2. Turn the machine power off.

FOR SAFETY: Before leaving or servicing machine, stop on level surface, set parking brake (if so equipped), turn off machine, and remove key.

3. Remove the squeegee from the machine. See *REMOVING THE SQUEEGEE ASSEMBLY*.
4. Remove the rear squeegee blade and retainer. See *REPLACING OR ROTATING THE REAR SQUEEGEE BLADE*.
5. Loosen the two remaining knobs on top of the squeegee assembly.
6. Pull the retainer plate back and pull out the front squeegee blade of the squeegee frame.
7. Insert the rotated or new squeegee blade in the squeegee frame, lining up the slots in the blade with the tabs on the retainer plate.



8. Push the retainer plate forward. Tighten the two outside knobs on top of the squeegee assembly.
9. Insert the rear squeegee blade and retainer. Tighten the two rear blade retention knobs until the ends of the front and rear squeegee blades touch. Do not overtighten.
10. Install the squeegee assembly on the squeegee pivot. See *INSTALLING THE SQUEEGEE ASSEMBLY*.
11. Adjust the squeegee blade leveling and deflection as stated in *LEVELING THE SQUEEGEE* and *ADJUSTING SQUEEGEE BLADE DEFLECTION*.

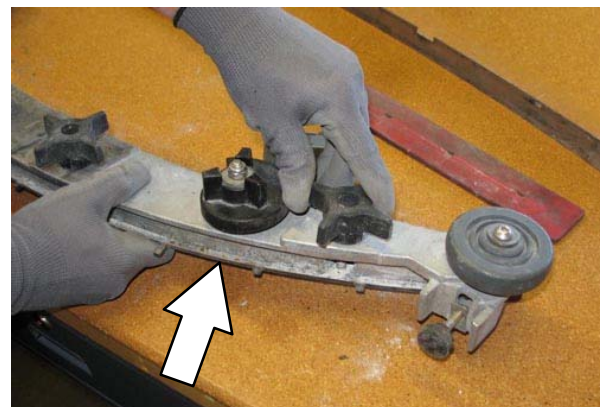

BELTS AND CHAINS

BRUSH DRIVE BELT

FOR SAFETY: Before leaving or servicing machine, stop on level surface, set parking brake (if so equipped), turn off machine, and remove key.

The two brush drive belts are located on the cylindrical brush scrub head. The belts drive the cylindrical brushes. Proper **new** belt tension is a 3 mm (0.1 in) deflection from a force of 1.37 to 1.48 kg (3.0 to 3.26 lb) at the belt midpoint.

When reusing an old belt, measure and record the belt tension before removal, so that the belt can be reinstalled at the same tension.

If the old belt tension was not recorded, the recommended force per old belts is 1.03 to 1.14 kg (2.28 to 2.52 lb) with a deflection of 3 mm (0.1 in).

Check the belt tension and wear every 100 hours of operation.

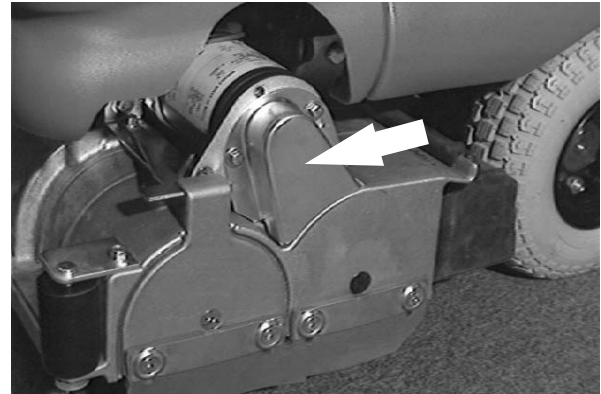

STATIC DRAG CHAIN

A static drag chain prevents the buildup of static electricity in the machine. The chain is attached to the transaxle.

Make sure the chain is always touching the floor.

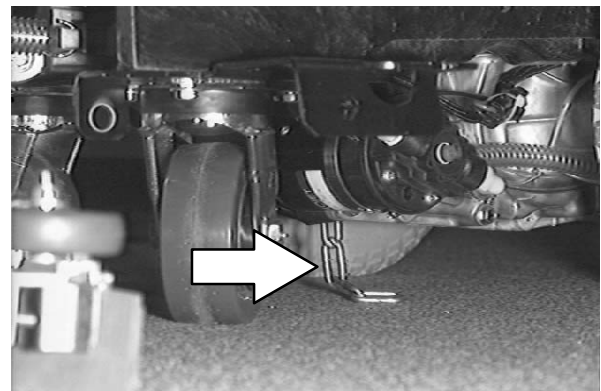

TIRES

FOR SAFETY: Before leaving or servicing machine, stop on level surface, set parking brake (if so equipped), turn off machine, and remove key.

The standard front tires are foam filled. Check tires for damage and wear after every 500 hours of operation.

The front wheel lug nuts should be tightened to 102 to 115 Nm.

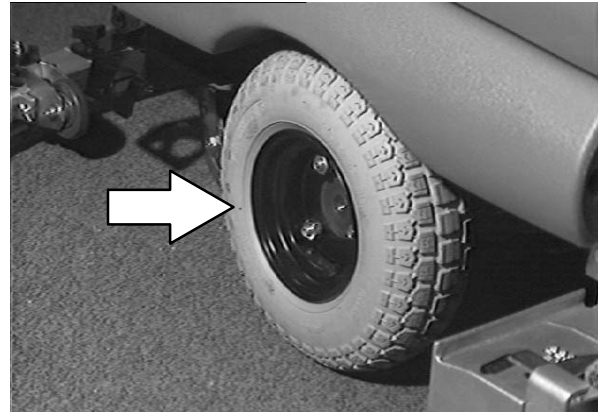

PUSHING AND TRANSPORTING THE MACHINE

PUSHING THE MACHINE

If the machine becomes disabled, it can be pushed if necessary.

Unplug the drive motor from the electrical harness before attempting to push a disabled machine. The machine will become easier to maneuver when it is unplugged.

ATTENTION! Do not push the machine for a long distance and without unplugging the drive motor or damage may occur to the propelling system.

Only push a disabled machine for a *very short distance* and do not exceed 3.2 kp/h. It is NOT intended to be pushed for a long distance or at a high speed.

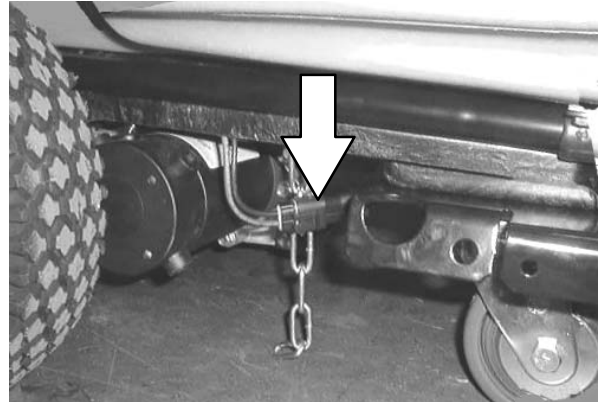

TRANSPORTING THE MACHINE

1. Raise the squeegee, scrub head, and brushes.

FOR SAFETY: When loading/unloading machine onto/off truck or trailer, drain tanks before loading machine.

2. Load the machine using a ramp that can support the machine weight and person loading it.
3. Position the front of machine up against the front of the trailer or truck. Lower the scrub head and squeegee.

FOR SAFETY: When loading/unloading machine onto/off truck or trailer, lower scrub head and squeegee before tying down machine.

4. Set the parking brake, if equipped, and place a block behind each wheel to prevent the machine from rolling.

FOR SAFETY: When loading/unloading machine onto/off truck or trailer, use a ramp that can support the weight of the machine and operator. Block machine tires. Tie machine down to truck or trailer.

5. Secure the tie-down straps to the tie-down brackets as shown and then route the tie-down straps diagonally over the top of the machine. It may be necessary to install tie-down brackets to trailer or truck.

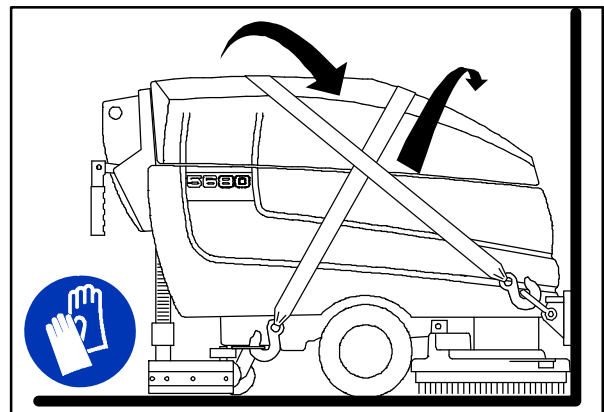

Secure the tie-down straps to the rear tie-down locations on both sides of the machine frame by the rear casters.

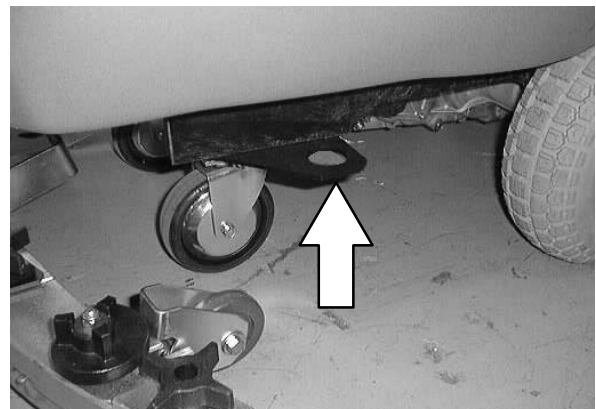

MACHINE JACKING

FOR SAFETY: Before leaving or servicing machine, stop on level surface, set parking brake (if so equipped), turn off machine, and remove key.

Check that both the solution and recovery tanks are empty before attempting to jack up the machine.

You can jack up the machine for service anywhere under the recovery tank. Use a piece of wood to distribute the machine weight load.

Always stop the machine on a flat level surface and block the machine tires before jacking up the machine.

FOR SAFETY: When servicing machine, block machine tires before jacking machine up. Use a hoist or jack that will support the weight of the machine. Jack machine up at designated locations only. Support machine with jack stands.

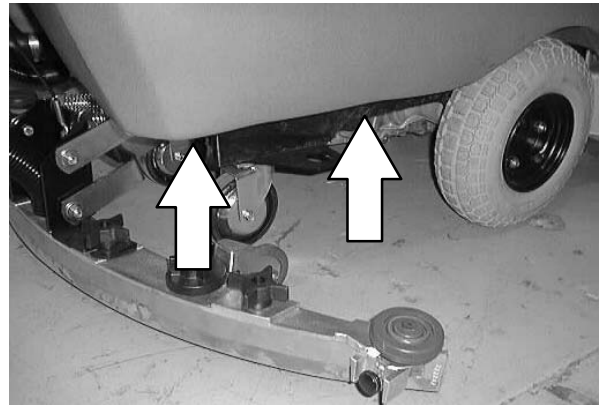

STORAGE INFORMATION

The following steps should be taken when storing the machine for extended periods of time.

1. Drain and clean the solution and recovery tanks.
2. Park the machine in a cool, dry area.
3. Remove the batteries, or charge them after every three months.

FREEZE PROTECTION

FOR SAFETY: Before leaving or servicing machine, stop on level surface, set parking brake (if so equipped), and turn off machine.

1. Drain the solution tank and recovery tank of all water.
2. Pour 2 gallons (8 liters) of recreational vehicle (RV) antifreeze into the solution tank at full strength. Do not dilute.
3. Turn the machine power on and operate the solution flow system. Turn the machine off when the red RV antifreeze is visible.

Continue with the freeze protection procedure if machine is equipped with the *ec-H2O* system.

***ec-H2O* Model:**

FOR SAFETY: Before leaving or servicing machine, stop on level surface, set parking brake (if so equipped), and turn off machine.

4. Press and release the flush switch on the *ec-H2O* module to cycle the antifreeze through *ec-H2O* system. When the antifreeze is visible, press the switch again to turn off the module. The module is located behind the front cover.

IMPORTANT: Before operating machine, the antifreeze must be flushed from the module as described below.

If the antifreeze is not properly flushed from the *ec-H2O* system, the *ec-H2O* module may detect an error and not function (*ec-H2O* switch indicator light will turn red). If this occurs, reset key and repeat the flush procedure as described below.

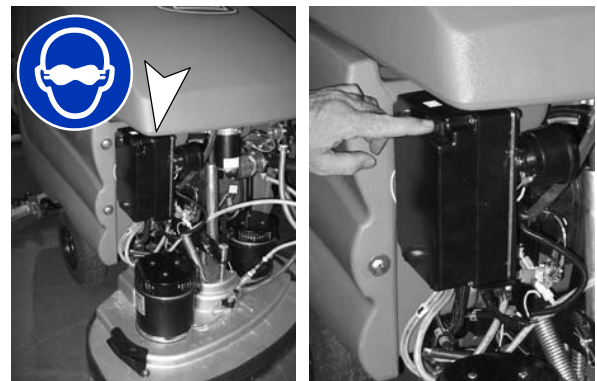

MAINTENANCE

FLUSHING ANTIFREEZE FROM *ec-H2O* MODULE

FOR SAFETY: Before leaving or servicing machine, stop on level surface, set parking brake (if so equipped), and turn off machine.

1. Drain the antifreeze from the solution tank into a bucket.
2. Fill the solution tank with cool water until full (See FILLING SOLUTION TANK).
3. Disconnect the black connector fitting at the scrub head and place the hose into a bucket. To access the connector fitting, you may have to remove the front cover from the machine.
4. Press and release the *ec-H2O* module flush switch to start the flush cycle. The module is located behind the front cover.

When the water turns clear, press the module switch again to stop the flush cycle.

Dispose the antifreeze in an environmentally safe way according to local waste disposal regulations.

5. The machine is now ready for scrubbing.

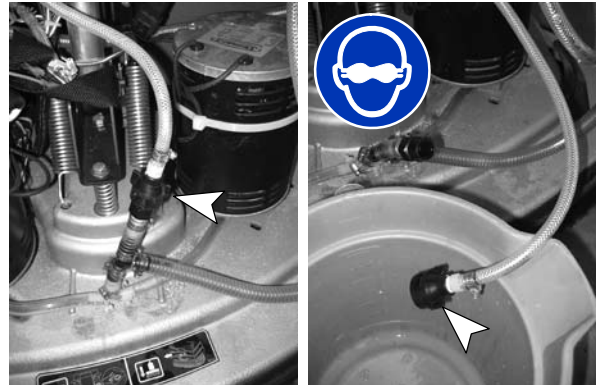

SPECIFICATIONS

GENERAL MACHINE DIMENSIONS/CAPACITIES

Item	Dimension/capacity
Length with cylindrical scrub head	1.600 mm
Length with 700 mm disk scrub head	1.625 mm
Length with 800 mm disk scrub head	1.660 mm
Length with 900 mm disk scrub head	1.690 mm
Width (less squeegee and scrub head)	720 mm
Height	1.090 mm
Disk brush diameter for 700 mm scrub head	355 mm
Disk brush diameter for 800 mm scrub head	405 mm
Disk brush diameter for 900 mm scrub head	455 mm
Cylindrical brush diameter	150 mm
Cylindrical brush length for 700 mm scrub head	695 mm
Cylindrical brush length for 800 mm scrub head	795 mm
Cylindrical brush length for 900 mm scrub head	900 mm
Squeegee width for 700 mm scrub head	950 mm
Squeegee width for 800 mm scrub head	1.065 mm
Squeegee width for 900 mm scrub head	1.155 mm
Scrubbing path width for 700 mm scrub head	700 mm
Scrubbing path width for 800 mm scrub head	800 mm
Scrubbing path width for 900 mm scrub head	900 mm
Solution tank capacity (recommended usage)	114 L
Solution tank capacity (maximum)	133 L
Recovery tank capacity to full sensor	114 L
Recovery tank capacity to top of tank	152 L
Transaxle 90 weight gear lubricant capacity	1,42 L
GVWR	690 kg

Values determined as per EN 60335-2-72	Measure
Sound pressure level L_{pA}	66 dB(A)
Sound uncertainty K_{pA}	3 dB(A)
Sound power level L_{WA} + Uncertainty K_{WA}	84 dB(A)
Vibration – Hand–arm	<2.5 m/s^2

SPECIFICATIONS

GENERAL MACHINE PERFORMANCE

Item	Measure
Aisle turnaround width with 700 mm scrub head	1.685 mm
Aisle turnaround width with 800 mm scrub head	1.700 mm
Aisle turnaround width with 900 mm scrub head	1.715 mm
Maximum rated climb and descent angle with empty tanks	14.1%
Maximum rated climb and descent angle with full tanks	10.5%

FaST SYSTEM (OPTION)

Item	Measure
Solution pump	36 Volt DC, 5A, 5,7 LPM (1,5 GPM) open flow, 45 psi bypass setting
Solution flow rate	0,83 LPM (0,22 GPM)
Detergent pump	36 Volt DC
Concentrate flow rate	0,9 CC/Minute (0,03 Ounces/Minute)
Concentrate to water dilution ratio	1:1000
Air pump	24 Volt DC, 0,6 Maximum Amp draw
Air pump flow rate	8,7 LPM (0,3 CFM) open flow

ec-H2O SYSTEM (OPTION)

Item	Measure
Solution pump	36 Volt DC, 5A, 5,7 LPM (1,5 GPM) open flow, 45 psi bypass setting
Solution flow rate* – Disk 700 mm	0,83 L/min / 0,22 gpm (standard)
	1,25 L/min / 0,33 gpm (optional)
	1,66 L/min / 0,44 gpm (optional)
Solution flow rate* – Disk 800 mm	0,83 L/min / 0,22 gpm (standard)
	1,25 L/min / 0,33 gpm (optional)
	1,66 L/min / 0,44 gpm (optional)
Solution flow rate* – Disk 900 mm	1,10 L/min / 0,30 gpm (standard)
	1,66 L/min / 0,44 gpm (optional)
	2,00 L/min / 0,53 gpm (optional)
Solution flow rate* – Cylindrical 700 mm	1,25 L/min / 0,33 gpm (standard)
	1,66 L/min / 0,44 gpm (optional)
Solution flow rate* – Cylindrical 800 mm	1,25 L/min / 0,33 gpm (standard)
	1,66 L/min / 0,44 gpm (optional)
Solution flow rate* – Cylindrical 900 mm	1,66 L/min / 0,44 gpm (standard)
	2,00 L/min / 0,53 gpm (optional)

* If the optional solution flow rates are required, contact an Authorized Service Center.

POWER TYPE

Type	Quantity	Volts	Ah Rating	Weight
Batteries	6	6	235 @ 20 hr rate	30 kg
	6	6	335 @ 20 hr rate	47 kg

Type	Use	VDC	Kw
Electric Motors	Scrub brush (disk)	36	0,56
	Scrub brush (cylindrical)	36	0,56
	Vacuum fan	36	0,63
	Propelling	36	0,37

Type	VDC	amp	Hz	Phase	VAC
Chargers (Smart)	36	20	60	1	115
	36	30	60	1	115

TIRES

Location	Type	Size
Front (2)	Foam filled, non-marking	4,10/3,5 – 6
Rear, casters (2)	Solid, non-marking	127 mm x 35 mm

SPECIFICATIONS

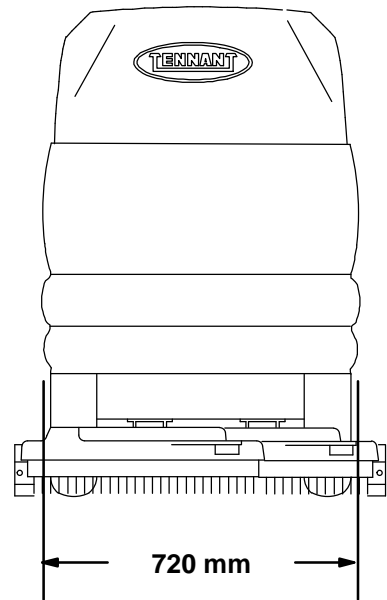
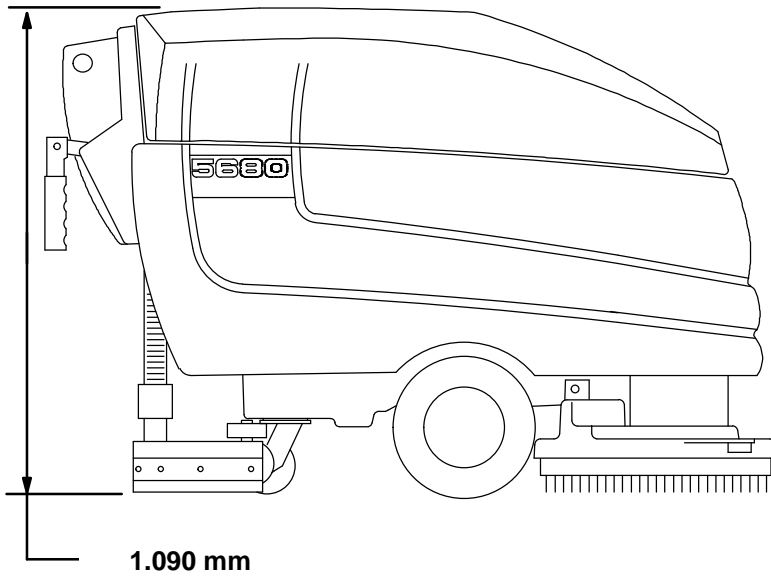
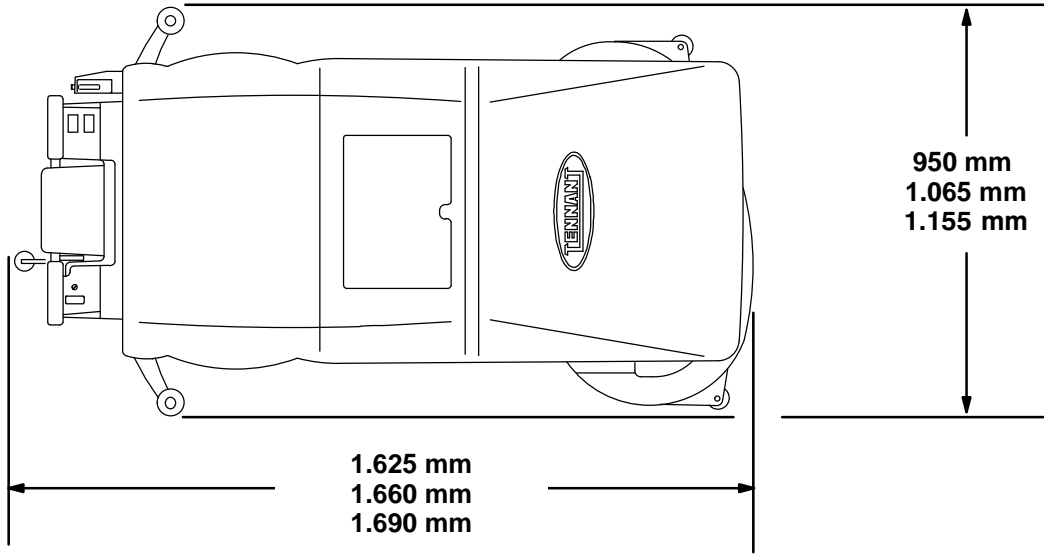

353416

MACHINE DIMENSIONS