

Dealer Service Instructions for:

## **Safety Recall No. 957 -- Owner's Manual Addendum**

NOTE: Safety Recall 957 is for release in the United States to satisfy a non-compliance issue regarding Federal Motor Vehicle Safety Standard (FMVSS) 225, Child Restraint Anchorage System **instructions** in the Owner's Manual. International vehicles are not involved in this Recall. The Owner's Manual Addendum's for the models listed below can be found on ITIL CD (February 2001 Series) by document number 957 for International owner's who request this information.

### **Models**

<b>2000-2001</b>	<b>(PL)</b>	<b>Dodge and Plymouth Neon Built From July 9, 1999 Through October 25, 2000 (MDH 0709XX through 102508)</b>
<b>2000</b>	<b>(JA)</b>	<b>Chrysler Cirrus, Dodge Stratus and Plymouth Breeze</b>
<b>2001</b>	<b>(JR)</b>	<b>Chrysler Sebring Sedan and Dodge Stratus Sedan Built Through October 25, 2000 (MDH 102516)</b>
<b>2000-2001</b>	<b>(LH)</b>	<b>Chrysler Concorde, LHS and 300M; and Dodge Intrepid Built Through October 28, 2000 (MDH 102800)</b>
<b>2000-2001</b>	<b>(PR)</b>	<b>Plymouth Prowler Built Through October 18, 2000 (MDH 101813)</b>
<b>2000-2001</b>	<b>(SR)</b>	<b>Dodge Viper Built Through October 19, 2000 (MDH 101900)</b>
<b>2001</b>	<b>(PT)</b>	<b>Chrysler PT Cruiser Built From July 10, 2000 Through October 27, 2000 (MDH 0710XX through 102707)</b>
<b>2001</b>	<b>(AB)</b>	<b>Dodge Ram Vans/Wagons Built Through October 27, 2000 (MDH 102713)</b>
<b>2001</b>	<b>(AN)</b>	<b>Dodge Dakota Built Through October 26, 2000 (MDH 102605)</b>

**Models (Continued)**

- 2001 (BR/BE) Dodge Ram Trucks Built at the:**
- **Warren Assembly Plant (“S” in the 11<sup>th</sup> VIN Position) From June 27, 2000 Through October 26, 2000 (MDH 0627XX through 102605)**
  - **St. Louis North Assembly Plant (“J” in the 11<sup>th</sup> VIN Position) From June 27, 2000 Through October 27, 2000 (MDH 0627XX through 102710)**
  - **Lago Alberto Assembly Plant (“M” in the 11<sup>th</sup> VIN Position) From July 25, 2000 Through October 29, 2000 (MDH 0725XX through 102900)**
  - **Saltillo Assembly Plant (“G” in the 11<sup>th</sup> VIN Position) From July 25, 2000 Through October 29, 2000 (MDH 0725XX through 102900)**
- 2001 (DN) Dodge Durango Built Through October 25, 2000 (MDH 102521)**
- 2001 (TJ) Jeep Wrangler Built Through October 20, 2000 (MDH 102012)**
- 2001 (XJ) Jeep Cherokee Built Through October 24, 2000 (MDH 102411)**
- 2001 (WJ) Jeep Grand Cherokee Built Through October 20, 2000 (MDH 102000)**

**IMPORTANT:** Some of the involved vehicles may be in Dealer new vehicle inventory. **Federal law requires you to stop sale and complete this recall service on these vehicles before retail delivery.** Dealers should also consider this requirement to apply to used vehicle inventory and should perform this recall on vehicles in for service. Involved vehicles can be determined by using the DIAL VIP System.

**Subject**

The owner’s manual supplied with about 1,210,000 of the above vehicles may have omitted certain information required under United States Federal Motor Vehicle Safety Standard (FMVSS) No. 225, which relates to child restraint anchorage systems. Federal regulations require that some specific instructions be provided in the owner’s manual to ensure that a child restraint system tether strap is properly attached and to identify the seat positions that have tether anchorages.

## Repair

Owner’s manual addendum cards are being mailed directly to all owners known to DaimlerChrysler with the owner notification letter. The owners are requested to insert the card into their owner’s manual. **Dealers must insert a copy of the correct addendum card into each affected unsold vehicle in Dealer inventory before retail delivery.**

## Parts Information

**Each Dealer** to whom vehicles in the recall were invoiced (or the current Dealer at the same street address) will receive enough Owner’s Manual Addendum Cards to service 100% of their UNSOLD vehicles.

Dealers should determine which addendum card is required for each vehicle by:

- **Using the part code in the third column of the VIN list along with the following table (involved Dealers);**
- **Using the VIN and part number list electronically transmitted to DIAL System Function 53 (involved Dealers); or**
- **Entering the VIN into the DIAL VIP system (body model information) along with the following table (all Dealers):**

Body Model	Part Code	Part Number
PR, SR	1	05072771AA
PL, JA, JR, LH, DN	2	05072774AA
XJ, WJ	3	05072777AA
TJ	4	05072779AA
PT	5	05072780AA
AN	6	05072781AA
BR, BE	7	05072783AA
AB	8	05072784AA

**Service Procedure**

1. Locate the Owner’s Manual in the vehicle’s glove box or in the storage compartment.
2. Insert the addendum card into the owner’s manual.
3. Place the Owner’s Manual back into the glove box or storage compartment.

**Completion Reporting and Reimbursement**

Claims for vehicles that have been serviced must be submitted on the DIAL System. **Claims submitted will be used by DaimlerChrysler to record recall service completions and provide Dealer payments.**

Use the following labor operation number and time allowance:

	<b>Labor Operation Number</b>	<b>Time Allowance</b>
Insert addendum card in owner’s manual	23-95-71-82	<b>NO CHARGE</b>

**FOR UNSOLD VEHICLES: Enter “ADDENDUM” in the part number section of your claim with a quantity of one (1). Enter \$5.00 WITH NO MARK UP for addendum card handling reimbursement.**

NOTE: See the Warranty Administration Manual, Recall Claim Processing Section, for complete recall claim processing instructions.

**Parts Return**

Not applicable.

**Dealer Notification and Vehicle List**

**All United States Dealers will receive an electronic list of involved vehicles.** The Vehicle List is arranged by Dealer code and in Vehicle Identification Number (VIN) sequence. The lists are for Dealer reference in arranging for service of involved vehicles.

**DIAL System Functions 53 and VIP**

All involved vehicles have been entered to DIAL System Functions 53 and VIP for Dealer inquiry as needed.

Function 53 provides involved Dealers with an updated VIN list of their incomplete vehicles. Completed vehicles are removed from Function 53 within several days of repair claim submission. To use this system, type “53” at the “ENTER FUNCTION” prompt, then type “ORD957”.

**Owner Notification and Service Scheduling**

All involved vehicle owners should be notified of the service requirement by their Dealer. Owners are requested to schedule appointments for this service. A sample copy of the owner notification letter is attached.

**Vehicle Not Available**

If a vehicle is not available for service for a known reason, let us know by describing the reason on a postcard and mail to:

DaimlerChrysler Corporation  
CIMS 482-00-85  
800 Chrysler Drive East  
Auburn Hills, Michigan 48326-2757

Please include the VIN number, campaign number and current owner information, if available.

Following the above procedures will expedite the processing of your claim.

**Additional Information**

If you have any questions or need assistance in completing this action, please contact your International Service and Parts manager.

International Service and Parts  
DaimlerChrysler Corporation

# DAIMLERCHRYSLER

## ***IMPORTANT CHILD RESTRAINT SYSTEM SAFETY INFORMATION***

Dear DaimlerChrysler Vehicle Owner:

DaimlerChrysler Corporation (USA) has determined that the owner's manual accompanying your 2000 or 2001 model year Dodge, Chrysler, Plymouth or Jeep® vehicle omitted certain information required under United States Federal Motor Vehicle Safety Standard (FMVSS) No. 225, which relates to child restraint anchorage systems. Federal regulations require that some specific instructions be provided in the owner's manual in order to ensure that you properly attach a child restraint system tether strap and to identify the seat positions that have tether anchorages. These specific instructions may have been omitted from the owner's manual supplied with your vehicle (identified on the enclosed form).

To ensure that you understand the proper way to attach a child restraint system tether strap and that you know which seat positions have tether anchorages, DaimlerChrysler is sending you the enclosed owner's manual addendum card. Please take the time to review the instructions and then place the card in the vehicle's glove box or storage compartment with your owner's manual. This will keep the card available for reference by you or future owners, if your vehicle is sold.

If you have any questions or concerns about this matter, please contact the DaimlerChrysler Customer Assistance Center at 1-800-853-1403. A representative will assist you.

We apologize for any inconvenience, but we are sincerely concerned about your safety. Thank you for your attention to this important matter.

International Service and Parts  
DaimlerChrysler Corporation

***Buckle up  
For  
Safety***

### OWNER'S MANUAL ADDENDUM

#### THIS ADDENDUM IS AN ADDITION TO THE CHILD RESTRAINT SECTION OF YOUR OWNER'S MANUAL

Child restraints having tether straps and hooks for connection to tether anchors have been available for some time. In fact, many child restraint manufacturers will provide add-on tether strap kits for certain of their older products. There is a tether strap anchor behind the passenger seat back. To attach the tether strap to the anchor, move the seat back fully forward. Pass the child restraint tether strap hook through the opening under the head restraint. Attach the hook to the anchor loop, recline the seat back full rearward and move the seat to its most rearward position. Install the child restraint according to the manufacturer's directions. Return the seat back to an upright position. Remove the slack from the tether strap according to the child restraint manufacturer's directions.

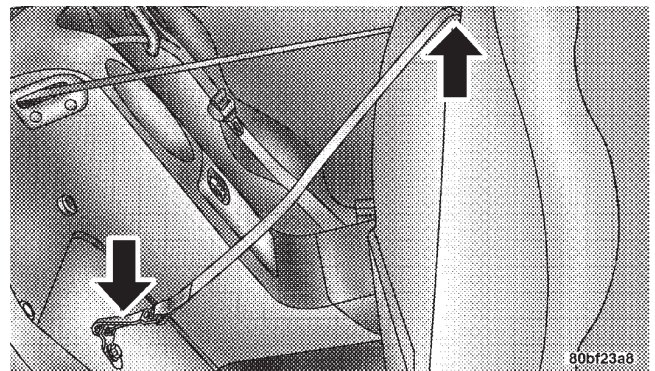
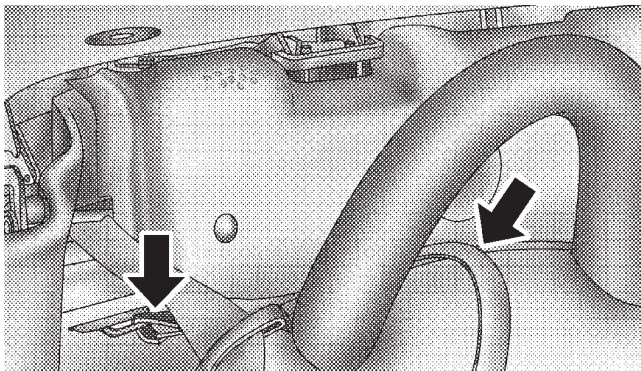

Illustration for Viper Only



**Illustration for Prowler Only**

**WARNING!**

**An incorrectly anchored tether strap could lead to increased head motion and possible injury to the child. Use only the anchor position directly behind the child seat to secure a child restraint top tether strap.**



**OWNER'S MANUAL ADDENDUM**

**THIS ADDENDUM IS AN ADDITION TO THE CHILD RESTRAINT SECTION OF YOUR OWNER'S MANUAL**

**To attach a child restraint tether strap:**

1) Lift the cover, if so equipped, over the anchor directly behind the seat where you are placing the child restraint.

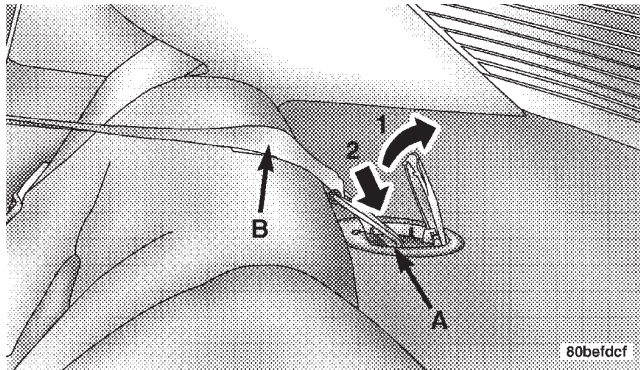

**Illustration applies to Sedans only**

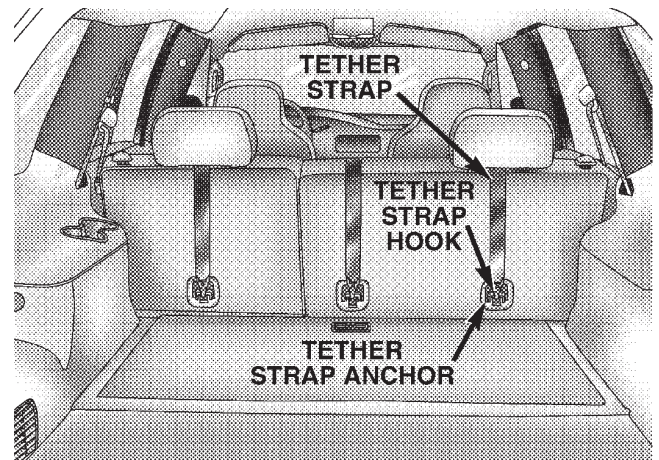

**Durango 5/6 Passenger Second Row**

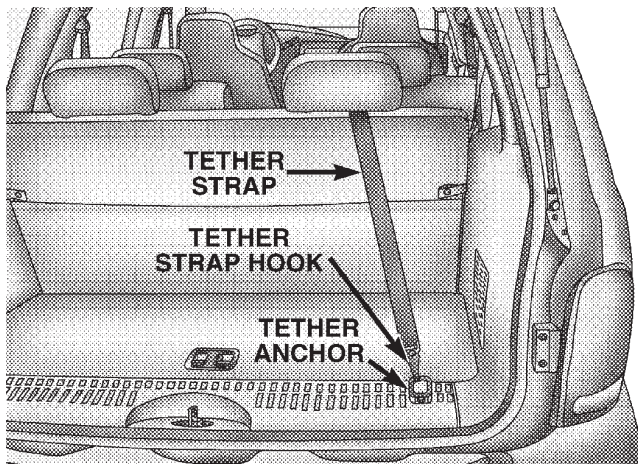

**Durango 7/8 Passenger Second and Third Row (Typical)**

2) Route the tether strap to provide the most direct path for the strap between the anchor and the child seat. If your vehicle is equipped with adjustable rear head restraints, raise the head restraint and, where possible, route the tether strap under the head restraint and between the two posts. If not possible, lower the head restraint and pass the tether strap around the outboard side of the head restraint.

3) Attach the tether strap hook (A) of the child restraint to the anchor (B) and remove slack in the tether strap according to the child restraint manufacturer's instructions.



DaimlerChrysler Corporation

05072774AA

81-026-1027B  
81-026-0027A  
81-026-1002B  
81-126-0002A  
81-026-1025B  
81-026-0025A  
81-226-1001B  
81-226-0001B  
81-026-1005B  
81-016-0005B  
81-326-1035C  
81-026-1003C  
81-226-1030D  
81-026-0003A  
81-226-0031A  
81-026-0030A  
81-026-1038A  
81-026-1039A

## OWNER'S MANUAL ADDENDUM

**THIS ADDENDUM PROVIDES INFORMATION TO BE ADDED TO THE CHILD RESTRAINT SECTION OF YOUR OWNER'S MANUAL.**

### **Child Restraint Tether Anchor**

To attach a child restraint tether strap hook to the anchor loop, first place the child restraint on the desired seat and adjust the strap length so that it will reach the anchor directly behind that seat. The anchors are above the rear liftgate and behind all rear seats in the Cherokee and behind the outboard rear seats in the Grand Cherokee. Raise the head restraint and route the tether strap under the head restraint and between the two posts. Pull down the anchor cover, if so equipped, and attach the hook to the anchor. Install the child restraint according to the manufacturers instructions, and tighten the vehicle seat belt. Remove the slack from the tether strap according to the child seat manufacturers instructions.

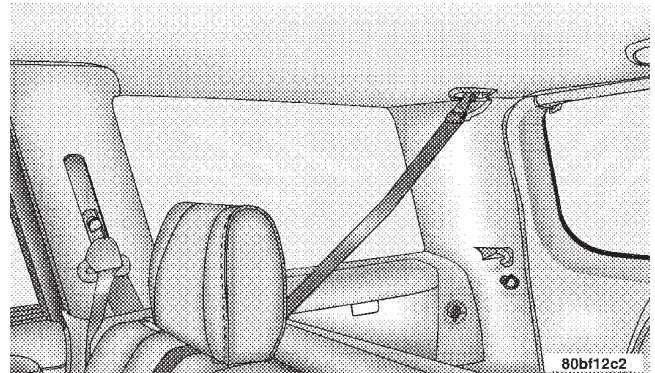

80bf12c2

**WARNING!**

**An incorrectly anchored tether strap could lead to increased head motion and possible injury to the child. Use only the anchor positions directly behind the child seat to secure a child restraint top tether strap.**

## OWNER'S MANUAL ADDENDUM

**THIS ADDENDUM PROVIDES INFORMATION TO BE ADDED TO THE CHILD RESTRAINT SECTION OF YOUR OWNER'S MANUAL.**

### Child Restraint Tether Anchor

Child restraints having tether straps and hooks for connection to tether anchors have been available for some time. In fact, many child restraint manufacturers will provide add-on tether strap kits for certain of their older products. There are tether anchors on the floor behind each rear outboard seating position.

To attach a child restraint tether strap hook to the anchor loop, first place the child restraint on the desired seat and adjust the strap length so that it will reach the anchor. Attach the hook to the anchor. If the "Add-A-Trunk" option is present in the vehicle, attach the hook to the anchor and route the tether strap over the "Add-A-Trunk" feature. Install the child restraint according to the manufacturers instructions, and tighten the vehicle seat belt. Remove the slack from the tether strap according to the child seat manufacturers instructions.

If there is no rear seat, the tether strap of a child restraint installed in the front passenger seat may be attached to the right hand tether anchor.

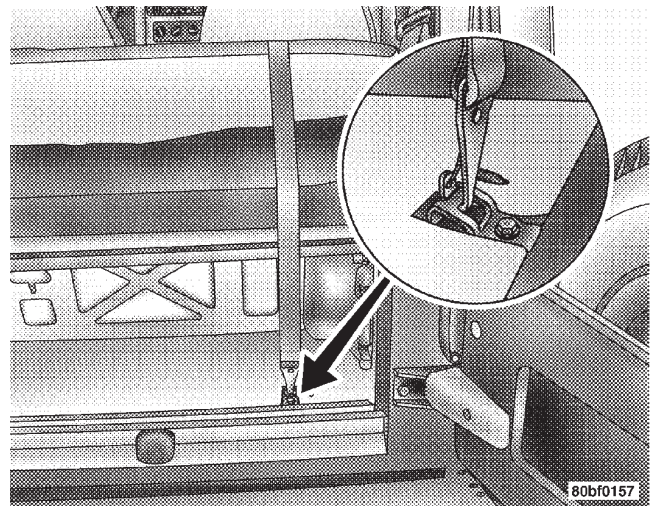

**WARNING!**

**An incorrectly anchored tether strap could lead to increased head motion and possible injury to the child. Use only the anchor positions directly behind the child seat to secure a child restraint top tether strap.**



## OWNER'S MANUAL ADDENDUM

This addendum replaces the Lower Anchors and Tether for CHildren (LATCH) information in the Child Restraint section of your owner manual.

### Lower Anchors and Tether for CHildren (LATCH)

Your vehicle is equipped with the child restraint anchorage system called LATCH, which stands for Lower Anchors and Tether for CHildren. The LATCH system provides for the installation of the child restraint without using the vehicle seat belt. All three rear seating positions have exclusive lower anchorages located at the rear of the seat cushion. They are round bars, part of the seat and body structure, and are readily visible. In addition, there are tether strap anchorages behind each rear seating position, located in the rear surface of the seat back.

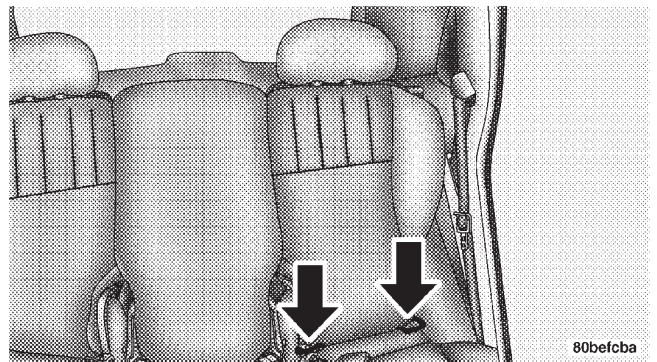

Child restraints systems having attachments designed to connect to the lower anchorages are now available. Child restraints having tether straps and hooks for connection to the top tether anchorage have been available for some time. In fact, many child restraint manufacturers will provide add-on tether strap kits for some of their older products. Tether anchorage kits are also available for most older vehicles.

Because the lower anchorages are to be introduced to passenger carrying vehicles over a period of years, child restraint systems having attachments for those anchorages will continue to have features for installation in vehicles using the lap or lap/shoulder belt. They will also have tether straps, and you are urged to take advantage of all of the available attachments provided with your child restraint in any vehicle.

### Installing the Child Restraint System

While there are LATCH anchorages at all three rear seating positions, do not install child restraints at all three positions at the same time. The anchorages are not designed to restrain three child restraints at one time. Instead, you may install one child restraint at the center position, or two child restraints at the right and left positions.

#### **WARNING!**

**Do not install child restraint systems equipped with LATCH attachments at all three rear seating positions at one time. The LATCH anchorages are designed to restrain no more than two child restraints at a time in the event of a collision.**

We urge that you carefully follow the directions of the manufacturer when installing your child restraint. Many, but not all, restraint systems will be equipped with separate straps on each side, with each having a hook or connector and a means for adjusting the tension in the strap. Forward-facing toddler restraints and some rearward-facing infant restraints will also be equipped with a tether strap with a hook and means for adjusting the tension in the strap.

In general, you will first loosen the adjusters on the lower and tether straps so that you can more easily attach the hook or connector to the lower and tether anchorages. The tether strap should be routed under the center of the head restraint and attached to the tether anchor on the rear of the seat back. Then tighten all three straps as you push the child restraint rearward and downward into the seat.

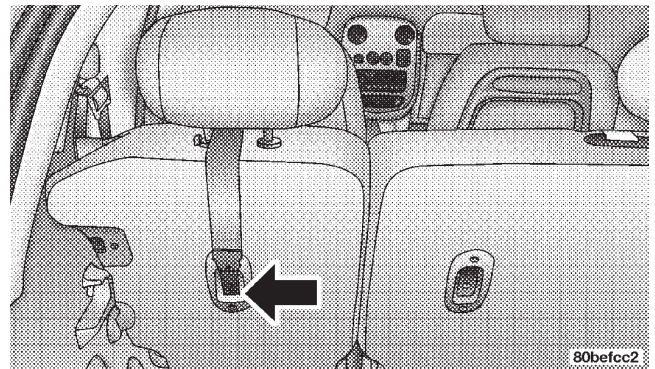

Not all child restraint systems will be installed as we have described here. Again, carefully follow the instructions that come with the child restraint system.

**WARNING!**

**An incorrectly anchored tether strap could lead to increased head motion and possible injury to the child. Use only the anchor position directly behind the child seat to secure a child restraint top tether strap.**

## OWNER'S MANUAL ADDENDUM

This addendum is an addition to the Child restraint section of your Owner's Manual.

### Child Restraint Tether Anchors

Child restraints having tether straps and hooks for connection to tether anchors have been available for some time. In fact, many child restraint manufacturers will provide add-on tether strap kits for certain of their older products. Regular Cab models of Dakota have two tether anchorages, one each behind the front center and right seats. Club Cab and Quad Cab models have three anchorages, one behind each of the rear seats.

### Tether Straps at the Right Front Seat (Regular Cab - All Seats)

1. Place the child restraint on the seat and adjust the tether strap so that it will reach over the seat back to the tether anchor directly behind the seat and over to the anchor behind the center seat.
2. Pass the tether strap hook through either the anchor outer or inner loop (with metal ring).

3. Route the tether strap across to the anchor installed directly behind the center seat, and attach the hook to the anchor metal ring.
4. Install the child restraint and remove the slack in the tether strap according to the manufacturer's instructions.

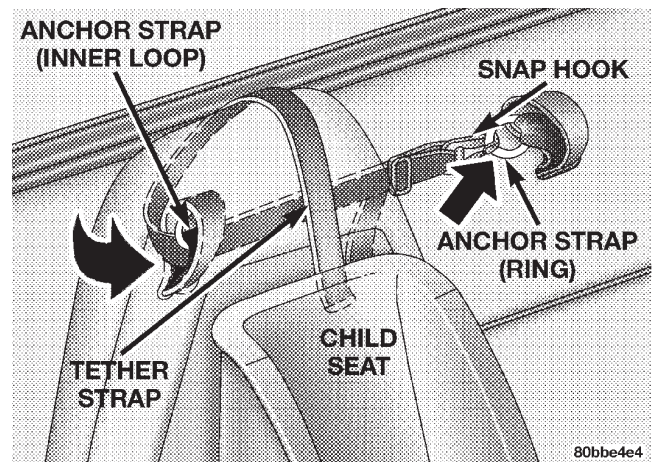

Regular Cab - All Seats

### **Tether Straps at the Front Center Seat (Regular Cab with Any Bench Seat)**

1. Place the child restraint on the seat and adjust the tether strap so that it will reach over the seat back to the tether anchor directly behind the seat and over to the anchor behind the right seat.
2. Pass the tether strap hook through the either the anchor outer or inner loop (with metal ring).
3. Route the tether strap across to the anchor installed directly behind the right seat, and attach the hook to the anchor metal ring.
4. Install the child restraint and remove the slack in the tether strap according to the manufacturer's instructions.

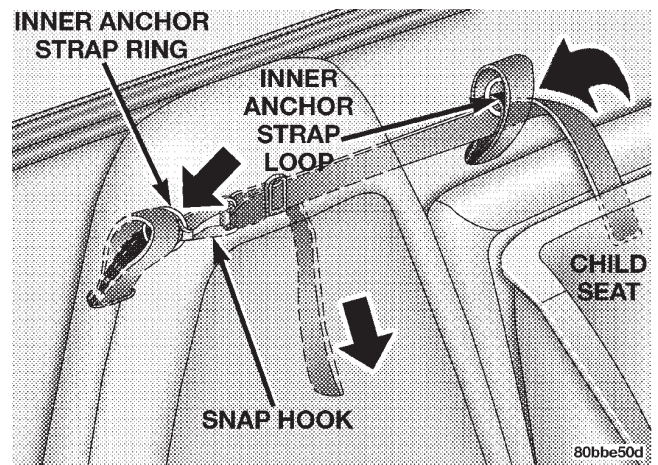

**Regular Cab with Any Bench Seat**

### **Tether Straps at any Rear Seat (Club Cab and Quad Cab Rear Seats)**

1. Place the child restraint on the seat and adjust the tether strap so that it will reach the tether anchor directly behind the seat and over to the next anchor.
2. Pass the tether strap hook through either the anchor outer or inner loop (with metal ring).
3. Route the tether strap across to the nearest anchor, and attach the hook to the anchor metal ring.
4. Install the child restraint and remove the slack in the tether strap according to the manufacturer's instructions.

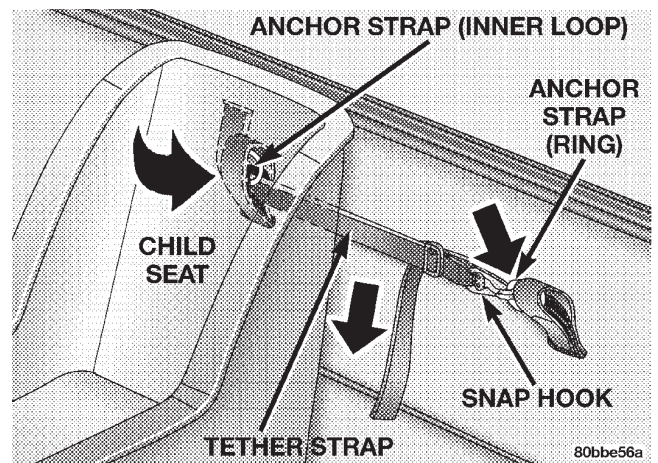

**Club Cab and Quad Cab Rear Seats**

### **Multiple Child Restraint Installation Sequence - Rear Seats (Club and Quad Cabs)**

1. Place a child restraint on each outboard rear seat and adjust the tether strap so that it will reach the tether anchor directly behind the seat and to the anchor directly behind the center rear seat.
2. Pass each tether strap hook through either the anchor outer or inner loop (with metal ring).
3. Route each tether strap to the anchor behind the center seat, and attach the hooks to the metal ring.

4. Place a child restraint on the center rear seat and adjust the tether strap so that it will reach the tether anchor directly behind the seat and to the anchor directly behind the right seat.

5. Install each child restraint and remove the slack in the tether strap according to the manufacturer's instructions.

**NOTE:** Two anchors must be used for each of the three seating positions.



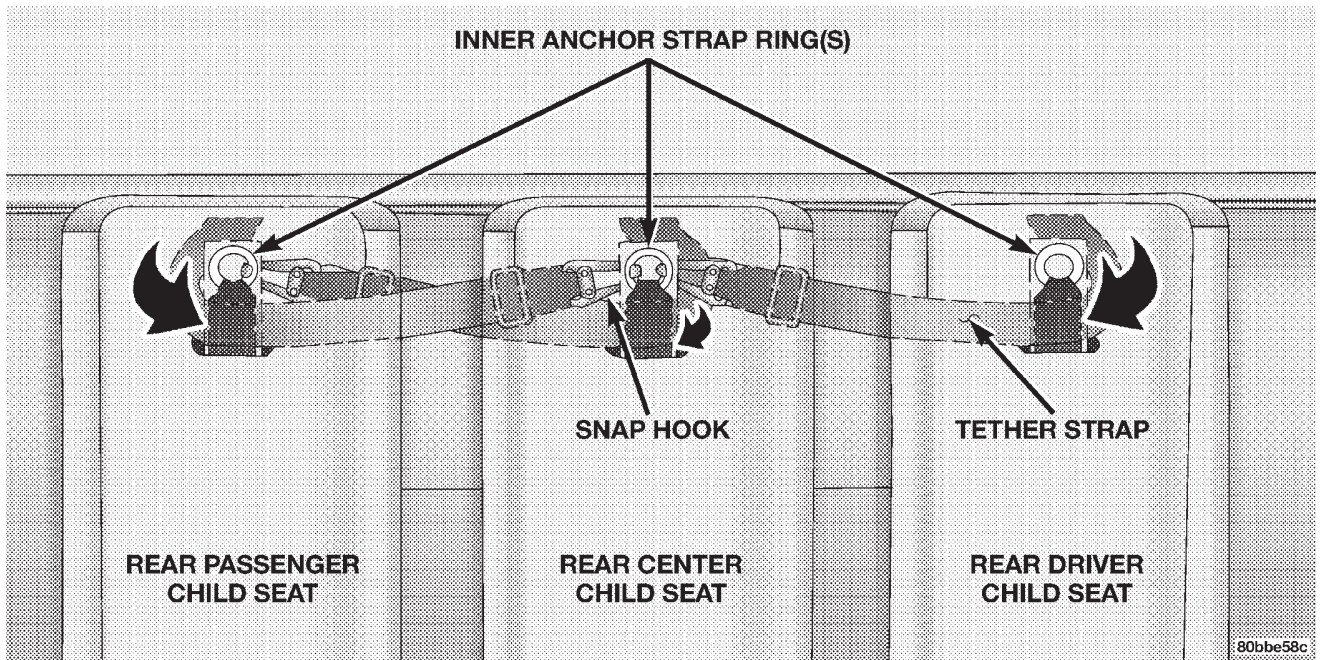

Multiple Child Restraint Installation Sequence

DaimlerChrysler Corporation

05072781AA

81-326-1034B

## OWNER'S MANUAL ADDENDUM

This addendum is an addition to the Child restraint section of your Owner's Manual.

### Child Restraint Tether Anchors

Child restraints having tether straps and hooks for connection to tether anchors have been available for some time. In fact, many child restraint manufacturers will provide add-on tether strap kits for certain of their older products. Regular Cab models of Ram Pickups have two tether anchorages, one each behind the front center and right seats. Quad Cab models have three anchorages, one behind each of the rear seats.

The Quad Cab Ram Pickup without a rear seat (rear seat delete option) has an anchor on the rear panel of the cab behind the center front seat, and another on the inboard seat adjuster.

### Tether Straps at the Right Front Seat (Regular Cab - All Seats)

1. Place the child restraint on the seat and adjust the tether strap so that it will reach over the seat back to the tether anchor directly behind the seat.

2. Lift the cover (if so equipped), and attach the hook to the anchor.
3. Install the child restraint and remove the slack in the tether strap according to the manufacturer's instructions.

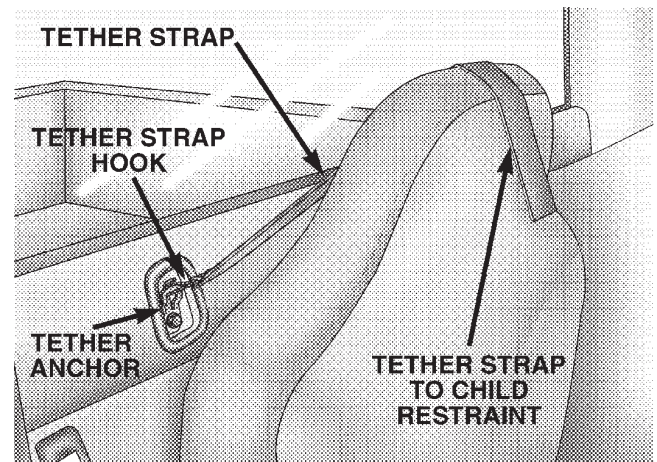

Regular Cab - All Seats

### **Tether Straps at the Right Front Seat (Quad Cab)**

1. Place the child restraint on the seat and adjust the tether strap so that it will reach over the seat back to the tether anchor located at the bottom rear of the seat on the inboard seat adjuster.

2. Attach the hook to the anchor.

3. Install the child restraint and remove the slack in the tether strap according to the manufacturer's instructions.

### **Tether Straps at the Front Center Seat (Regular Cab with Any Bench Seat)**

1. Place the child restraint on the seat and adjust the tether strap so that it will reach over the seat back to the tether anchor directly behind the seat.

2. Lift the cover (if so equipped), and attach the hook to the anchor.

3. Install the child restraint and remove the slack in the tether strap according to the manufacturer's instructions.

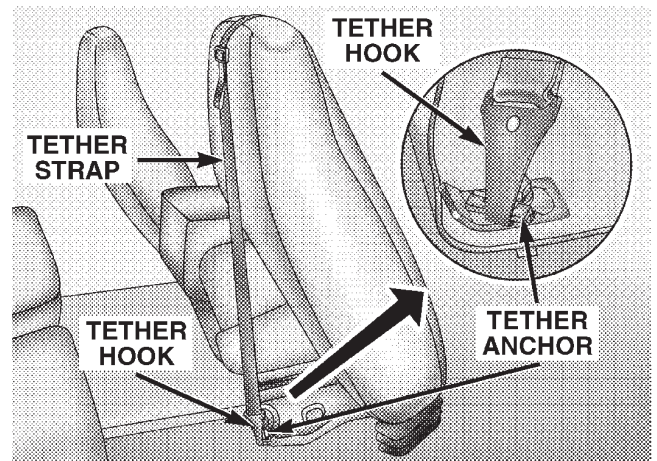

**Front Right Passenger Seat (Quad Cab)**

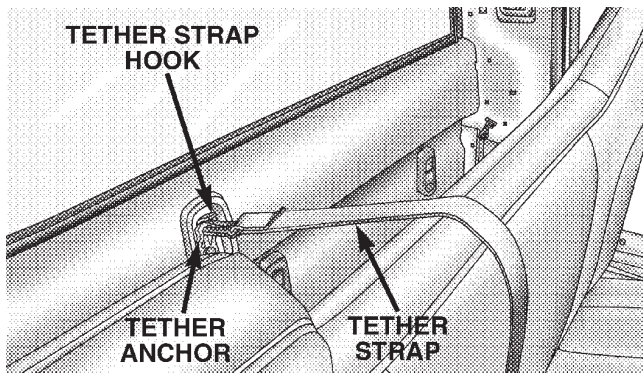

**Front Center Seat (Regular Cab with Any Bench Seat)  
Tether Straps at the Front Center Seat (Quad Cab without Rear Seat)**

1. Place the child restraint on the seat and adjust the tether strap so that it will reach over the seat back to the tether anchor on the rear cab wall directly behind the seat.

2. Lift the cover (if so equipped), and attach the hook to the anchor.

3. Install the child restraint and remove the slack in the tether strap according to the manufacturer's instructions.

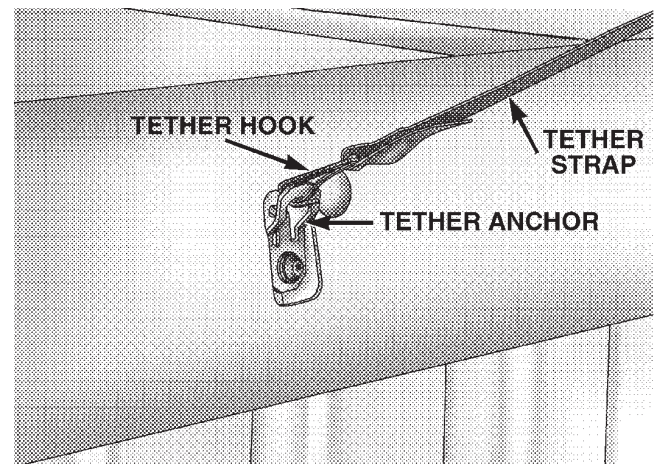

**Front Center Seat (Quad Cab without Rear Seat)**

### Tether Straps at any Rear Seat (Quad Cab Rear Seats)

1. Place the child restraint on the seat and adjust the tether strap so that it will reach the tether anchor directly behind the seat and to the next anchor.
2. Pass the tether strap hook through either the anchor outer or inner loop (with metal ring).
3. Route the tether strap across to the nearest anchor, and attach the hook to the anchor metal ring.
4. Install the child restraint and remove the slack in the tether strap according to the manufacturer's instructions.

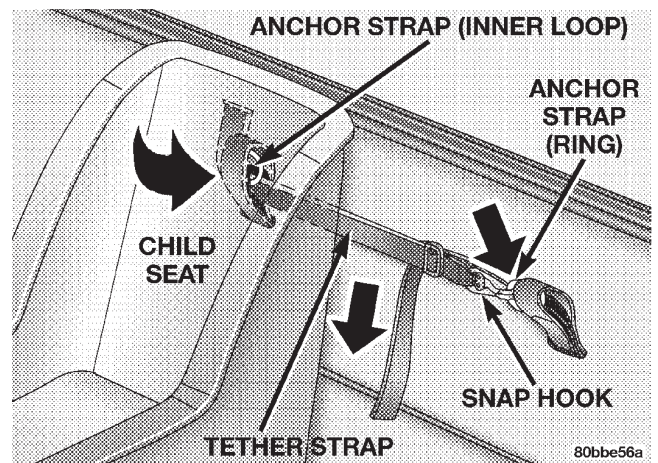

Quad Cab Rear Seats

**Multiple Child Restraint Installation Sequence -  
(Quad Cab Rear Seats)**

1. Place a child restraint on each outboard rear seat and adjust the tether strap so that it will reach the tether anchor directly behind the seat and to the anchor directly behind the center rear seat.
2. Pass each tether strap hook through either the anchor outer or inner loop (with metal ring).

3. Route each tether strap to the anchor behind the center seat, and attach the hooks to the metal ring.
4. Place a child restraint on the center rear seat and adjust the tether strap so that it will reach the tether anchor directly behind the seat and to the anchor directly behind the right seat.
5. Install each child restraint and remove the slack in the tether strap according to the manufacturer's instructions.

**NOTE:** Two Anchors must be used for each of the three seating positions.



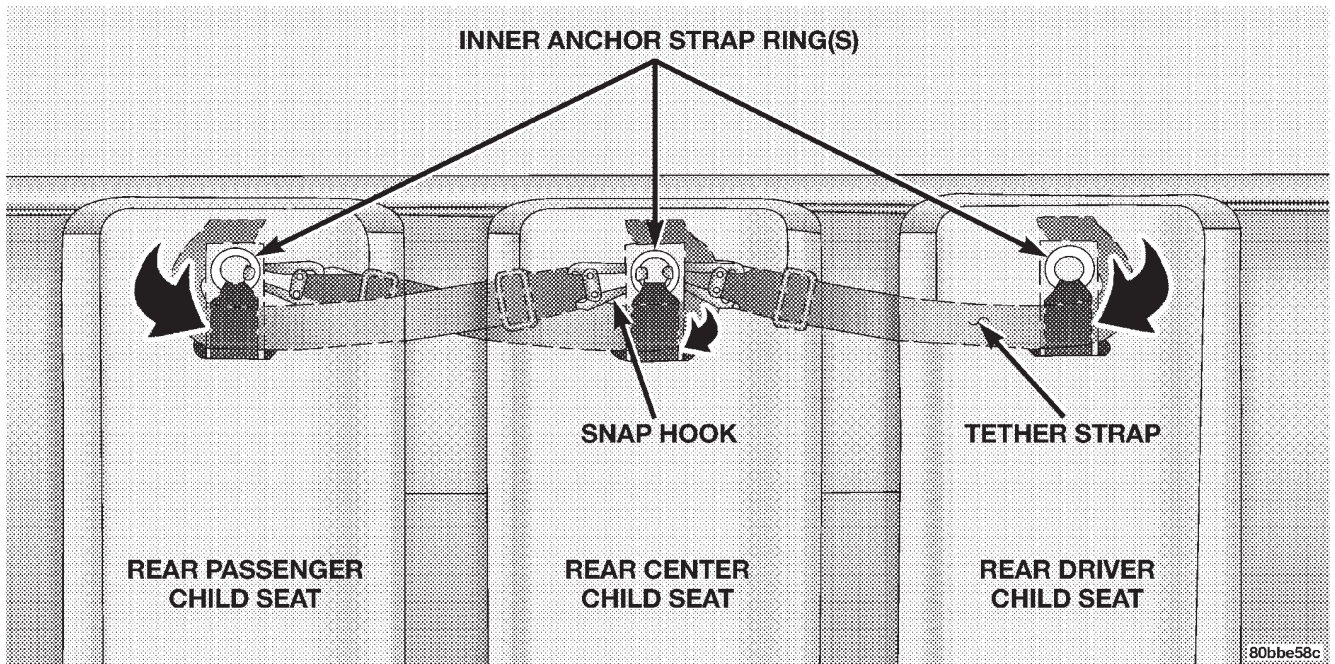

Multiple Child Restraint Installation Sequence



## OWNER'S MANUAL ADDENDUM

**This addendum is an addition to the Child restraint section of your Owner's Manual.**

There are tether anchors in your vehicle, however, they are at different positions in the Front Seat than in the Rear Seats.

Ram Van Front Passenger Seat - A tether anchor is located at the bottom of the passenger seat back in the seat base.

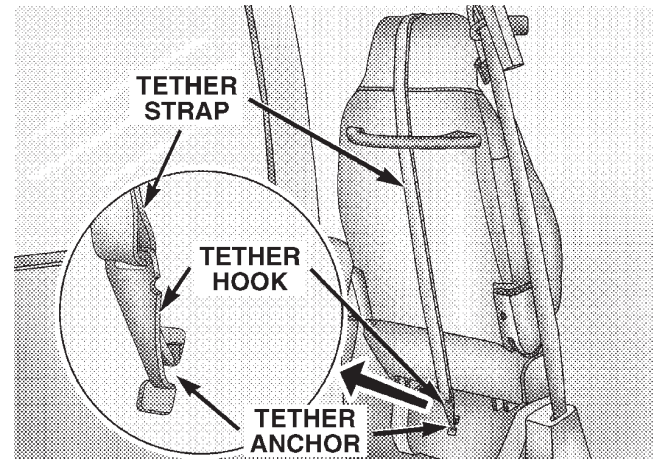

**Ram Van Front Passenger Seat**

Ram Wagon - Tether anchors, steel loops, are at the bottom of the seat back behind the center and right hand seats in the three passenger bench seats in nine, twelve, and fifteen passenger Wagons.

<b>WARNING!</b>
<b>An incorrectly anchored tether strap could lead to increased head motion and possible injury to the child. Use only the anchor positions directly behind the child seat to secure a child restraint top tether strap.</b>

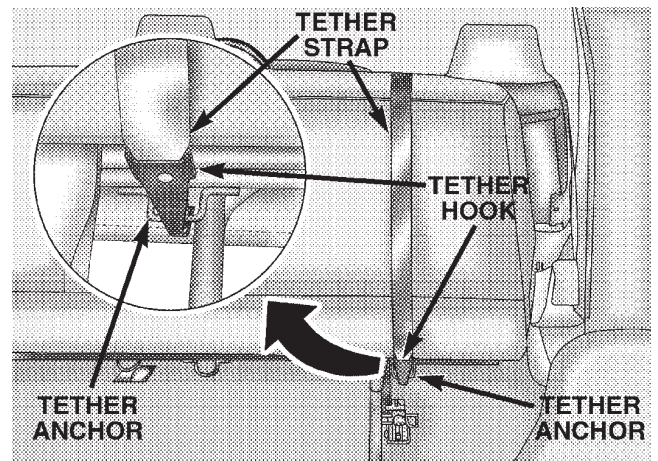

Ram Wagon Rear Passenger seat(s) (Typical)

To attach the tether strap hook to an anchor, place the child restraint on one of the seats above for either the Van or Wagon, and adjust the length of the tether strap so that it will reach over the seat back to the anchor directly behind the seat. Attach the strap hook to the anchor. Install the child restraint according to the manufacturer's

instructions, and tighten the vehicle seat belt. Remove the slack from the tether strap according to the manufacturer's instructions.

DaimlerChrysler Corporation

05072784AA

81-326-1025B