

SKF ConCentra ball bearing units

True concentric locking, for fast and reliable mounting





The SKF® brand now stands for more than ever before, and means more to you as a valued customer.

While SKF maintains its leadership as the hallmark of quality bearings throughout the world, new dimensions in technical advances, product support and services have evolved SKF into a truly solutions-oriented supplier, creating greater value for customers.

These solutions encompass ways to bring greater productivity to customers, not only with breakthrough application-specific products, but also through leading-edge design simulation tools and consultancy services, plant asset efficiency maintenance programmes, and the industry's most advanced supply management techniques.

The SKF brand still stands for the very best in rolling bearings, but it now stands for much more.

SKF – the knowledge engineering company

Contents

A Product information

- 3 **SKF ConCentra ball bearing units**
- 4 **SKF ConCentra – a truly innovative concentric locking technology**
 - 4 The plummer (pillow) block housing
 - 5 The deep groove ball bearing
 - 5 The ConCentra stepped sleeve
- 6 **Applications**

B Recommendations

- 8 **Selection of a bearing unit size**
- 10 **Design of bearing unit arrangements**
- 12 **Lubrication and maintenance**
- 14 **Mounting and dismounting**
 - 14 Mounting
 - 15 Dismounting

C Product data

- 16 **Product data – general**
- 18 **Product tables**
 - SKF ConCentra ball bearing units with plummer block housing
 - 18 for metric shafts
 - 20 for inch shafts

D Additional information

- 22 **Other SKF bearing units**
- 24 **SKF – the knowledge engineering company**

SKF ConCentra ball bearing units

SKF has added ConCentra ball bearing units to its extensive line of ready-to-install mounted products. These ball bearing units complement existing products lines like

- ball bearing and Y-bearing units
- collar mounted roller bearing units
- ConCentra roller bearing units.

The new SKF ConCentra ball bearing unit, with its true concentric location on the shaft, enables full utilization of the insert bearing's speed capability and is suitable for applications where there are relatively high speeds and moderate loads and where vibration, low noise, and minimal maintenance are key operational parameters. Typical applications include ventilation systems where even though commercial shafting is used; there is still a need to run continuously and quietly for long periods of time under harsh operating conditions.

When compared to standard ball bearing units, the SKF ConCentra ball bearing unit can provide a number of advantages including

- longer service life
- higher operational reliability
- quicker mounting
- less maintenance
- simplified replacement
- worldwide availability to benefit manufacturers and end users alike.

SKF ConCentra ball bearing units are available from stock as plummer block units for 25 to 60 mm diameter metric shafts and for 1 to 2 ¹⁵/₁₆ inch diameter shafts. For other housing designs, such as flanged units, please contact the SKF application engineering service.



SKF ConCentra – a truly innovative concentric locking technology

SKF ConCentra ball bearing units are based on

- the reliable, proven design of the SKF SY series plummer block housing
- a 62 series deep groove ball bearing
- a completely new ConCentra stepped sleeve developed by SKF.

The stepped sleeve is characterized by its highly efficient, low cross section design.

SKF ConCentra ball bearing units are filled with a premium bearing grease and are maintenance-free under normal operating conditions. These units are provided with a grease nipple so that bearing units operating under severe conditions can be relubricated.

The housings are coated with epoxy paint, providing very good corrosion resistance. A solventless rust inhibitor protects blank surfaces.

Fig. 1



The plummer (pillow) block housing

SKF ConCentra ball bearing units are based on SKF's proven plummer block housings (→ fig. 1) in

- the SY 5(00) M series for metric shafts
- the SY 5(00) U/AH series for inch shafts.

The housings are made from grey cast iron. They have a concave sphered bore and can, together with the incorporated bearing, accommodate initial misalignment.

The attachment holes cast in the base are oblong to easily and accurately align the bearing units and shaft.

Housings in the SY 5(00) U/AH series for inch shafts feature a solid base.

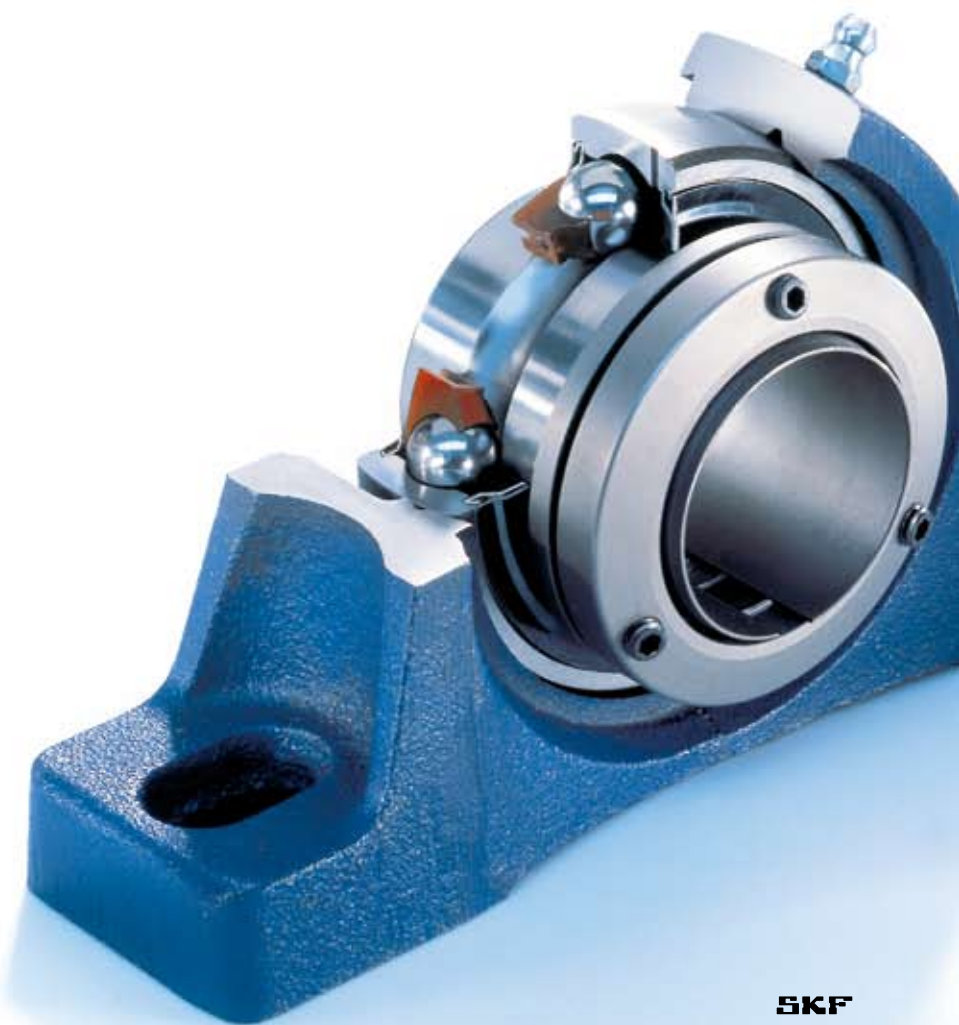

The deep groove ball bearing

The bearings used in SKF ConCentra ball bearing units are based on deep groove ball bearings in the 62 series. These bearings have a convex sphered outside surface. The inner ring is extended on both sides and has a multi-tapered bore (→ fig. 2).

The bearing is sealed on both sides with the highly-efficient SKF "Superagriseal", which is complemented by flingers to considerably enhance the sealing effect without increasing friction. It is filled with a premium grease with a lithium-calcium thickener that fills between 25 and 35 % of the free space in the bearing. If necessary, the bearing unit can be relubricated via a grease nipple in the housing.

The ConCentra stepped sleeve

The ConCentra stepped sleeve, a masterpiece of locking technology, is the real innovation behind the SKF ConCentra bearing unit (→ fig. 3). The locking concept is based on two mating surfaces with precision-engineered inclined serrations on their contact surfaces. These mating surfaces respond to axial displacement by expanding and contracting evenly around the entire circumference of the shaft. The stepped sleeve is equipped with a mounting and pressure ring (→ fig. 4).

By tightening the grub (set) screws in the mounting ring, using the hexagonal key (allen wrench) supplied with each unit, the pressure ring forces the inner ring up the inclined planes of the stepped sleeve to provide a true concentric tight fit on the shaft (→ fig. 5).

SKF ConCentra locking technology enables a bearing to operate with maximum reliability – improving both function and service life.



Fig. 2



Fig. 3

Prior to installation

The two mating surfaces with precision-engineered serrations in the bearing bore and on the sleeve outside diameter are positioned to provide clearance around the shaft

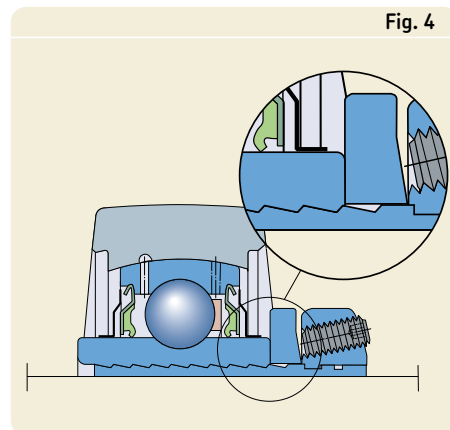

Fig. 4

During installation

The mating surfaces are axially displaced by tightening the grub screws, which forces the bearing ring to expand and the sleeve to contract, providing a true concentric, tight friction joint with the shaft

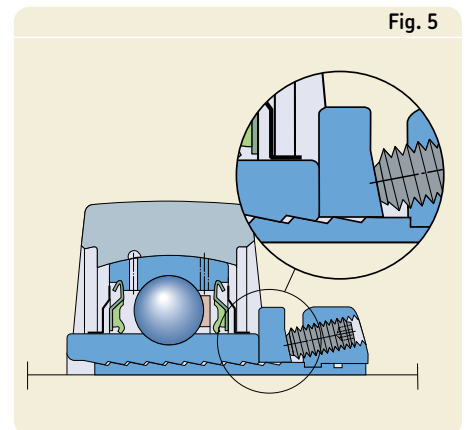

Fig. 5

Applications

Appropriate for a wealth of applications

- Conveyor systems
- Agricultural machinery
- Forestry machinery
- Air-handling equipment
- Handling systems
- Process fans
- Pumps
- Textile machines
- Food processing machines
- Printing and packaging machines

Fulfil all requirements

- Ready-to-mount and ready-to-operate
- High load carrying capacity
- Full exploitation of the insert bearing's speed capability
- High operational reliability
- Low noise and vibration levels
- Simple mounting
- Minimum maintenance
- Extremely long service life
- Worldwide availability
- Application engineering service

The brand new SKF solution:

The SKF ConCentra ball bearing unit



Refined technology

SKF ConCentra ball bearing units are part of SKF's commitment to the "Total Shaft Solutions" programme to provide a wide range of innovative bearing products to the air handling, conveyor equipment, fluid machinery, agricultural and forestry industries.

SKF ConCentra ball bearing units, with their true concentric locking mechanism, are friction assemblies that will provide optimum performance in applications where there is a need for reduced vibration levels because of relatively high rotational speeds. There is no comparable bearing unit available on the market that can be mounted or dismounted as fast as the SKF ConCentra technology allows. Where bearing units with eccentric locking technology had been used before, SKF ConCentra ball bearing units will provide superior performance.



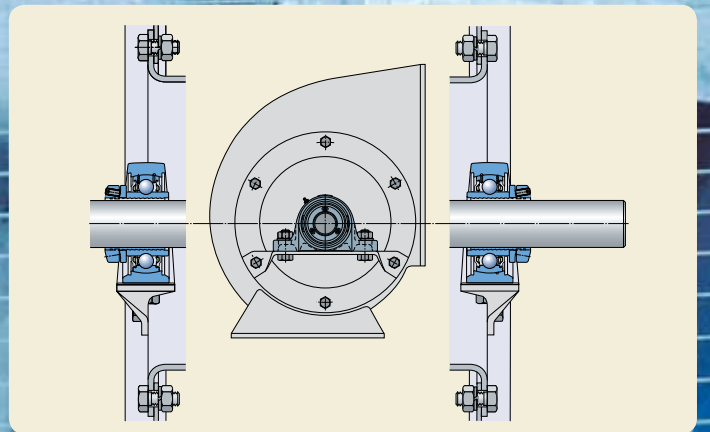
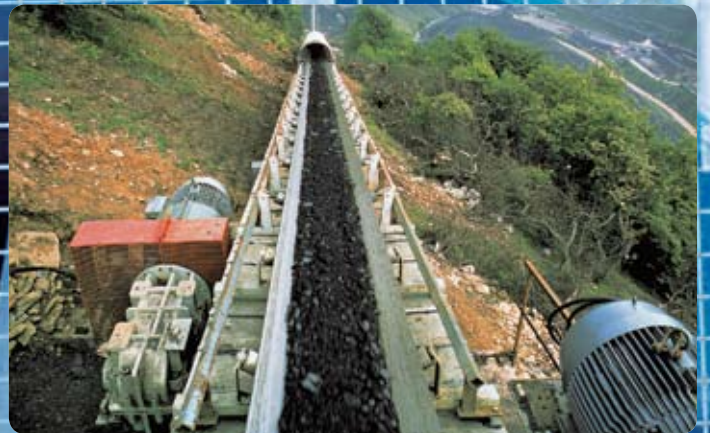

Selection of a bearing unit size

The size of an SKF ConCentra ball bearing unit is initially selected on the basis of the loads within the application, the bearing load carrying ability, its calculated life and reliability. The load carrying ability is expressed by the basic dynamic and basic static load ratings. The basic dynamic load ratings are determined in accordance with the methods described by ISO 281:1990 while the basic static load ratings are in accordance with ISO 76:1987.

The simplest method to calculate bearing life is to use the ISO 281:1990 equation for basic rating life, which is

$$L_{10} = \left(\frac{C}{P} \right)^3$$

For ball bearing units operating at constant rotational speed, it may be more convenient to deal with basic rating life expressed in operating hours, using the equation

$$L_{10h} = \frac{1\,000\,000}{60\,n} \left(\frac{C}{P} \right)^3$$

The life-extending improvements embodied in SKF ConCentra ball bearing units can best be understood by using the SKF rating life equation

$$L_{nm} = a_1 a_{SKF} \left(\frac{C}{P} \right)^3$$

or

$$L_{nmh} = a_1 a_{SKF} \frac{1\,000\,000}{60\,n} \left(\frac{C}{P} \right)^3$$

where

- L_{nm} = SKF rating life (at $100 - n^1$ % reliability), millions of revolutions
- L_{nmh} = SKF rating life (at $100 - n^1$ % reliability), operating hours
- L_{10} = basic rating life (at 90 % reliability), millions of revolutions
- L_{10h} = basic rating life (at 90 % reliability), operating hours
- a_1 = life adjustment factor for reliability (→ **table 1**)
- a_{SKF} = SKF life modification factor (→ **diagram 1**)
- C = basic dynamic load rating, kN
- P = equivalent dynamic bearing load, kN (→ **page 17**)
- n = rotational speed, r/min

This calculation method, which is in accordance with ISO 281:1990/Amd 2:2000 is better able to predict bearing service life. The a_{SKF} factor represents a very complex relationship between various influencing factors: the fatigue load limit P_u by the ratio P_u/P , the contamination level by the factor η_c and the lubrication conditions by the viscosity ratio κ .

More detailed information about

- selection of a bearing unit size
- the fatigue load limit P_u
- the contamination level η_c
- determining the viscosity ratio κ
- allocating a value for the SKF life modification factor a_{SKF}

can be found in the SKF General Catalogue or the "SKF Interactive Engineering Catalogue", available on CD-ROM or online at www.skf.com.

Values for the fatigue load limit P_u are provided in the product tables.

¹⁾ The factor n represents the failure probability, i.e. the difference between the requisite reliability and 100 %

SKF life modification factor a_{SKF}

Values of a_{SKF} can be obtained from **diagram 1** for different values of $\eta_c (P_u/P)$ and viscosity ratio κ . **Diagram 1** has been drawn up for a safety factor commonly used in fatigue life considerations. Values for a_{SKF} can also be obtained by using the calculation programs provided in the “SKF Interactive Engineering Catalogue” on CD-ROM or online at www.skf.com.

Contamination – the factor η_c for contamination level

It is not possible to allocate precise values to η_c that have general validity for SKF ConCentra ball bearing units. However, since SKF ConCentra ball bearing units are protected by very efficient seals, guideline values for the contamination factor η_c between 0,5 and 0,8 can be used to determine the a_{SKF} factor.

Lubrication conditions – the viscosity ratio κ

For SKF ConCentra ball bearing units, the viscosity ratio κ is calculated as the ratio between the actual operating viscosity ν to the rated viscosity ν_1 for adequate lubrication. To determine the operating viscosity use the kinematic base oil viscosity of 165 mm²/s at 40 °C and 15 mm²/s at 100 °C.

Table 1

Values for life adjustment factor a_1

Reliability %	Failure probability n %	SKF rating life L_{nm}	Factor a_1
90	10	L_{10m}	1
95	5	L_{5m}	0,62
96	4	L_{4m}	0,53
97	3	L_{3m}	0,44
98	2	L_{2m}	0,33
99	1	L_{1m}	0,21

Diagram 1

Factor a_{SKF} for radial ball bearing units

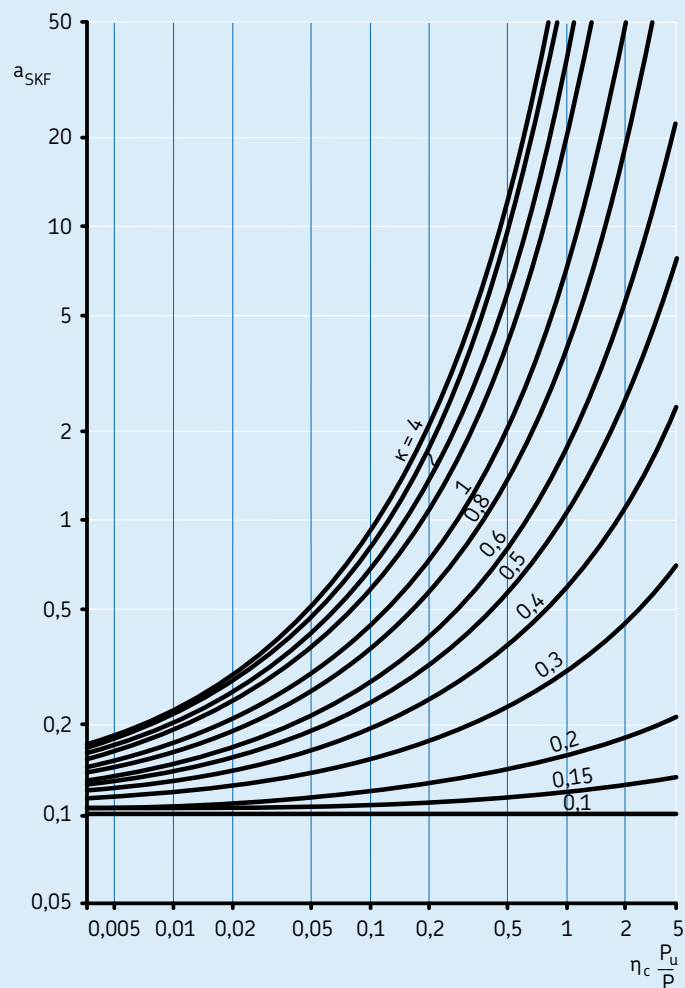

If $\kappa > 4$, use curve for $\kappa = 4$

As the value of $\eta_c (P_u/P)$ tends to zero, a_{SKF} tends to 0,1 for all values of κ

Design of bearing unit arrangements

Axial displacement

SKF ConCentra ball bearing units can accommodate only limited axial displacements resulting from thermal expansion of the shaft. The distance between unit positions should therefore be short. The units could be supported by resilient sheet metal support surfaces or walls to prevent them from being subjected to excessive stresses as a result of thermal elongation of the shaft.

Permissible initial misalignment

SKF ConCentra ball bearing units accommodate initial misalignment between the support surfaces

- up to 5° when relubrication is not required
- up to 2° when relubrication is required.

Additionally, they tolerate operational shaft deflections up to 3 minutes of arc.

Shaft tolerances

SKF ConCentra ball bearing units can be used with solid or hollow commercial grade shafts. The diameter tolerances must be kept within the limits listed in **table 1**. However shafts or seatings machined to tolerance h9 and having a cylindricity tolerance to IT5 will be satisfactory.

Support surfaces

To maximize the service life of an SKF ConCentra ball bearing unit, SKF recommends finishing support surfaces to a roughness of $R_a \leq 12,5 \mu\text{m}$ and a flatness that meets IT7 specifications. For moderate demands IT8 may be satisfactory.

SKF ConCentra ball bearing units are designed for loads acting vertically to the housing base support. If they are subjected to moderate or heavy loads acting parallel to the base support, a stop should be provided, or the units should be pinned to their support surface. The appropriate positions for these dowel pins are indicated by dimples in the housing base of SKF ConCentra units for metric shafts and are listed in **table 2**.

To attach SKF ConCentra plummer block units to their base, SKF recommends using hexagonal socket head cap screws according to EN ISO 4762:1998 with washers to EN ISO 7089:2000 or EN ISO 7090:2000. The combination of a hexagonal socket head cap screw and a flat washer provides improved seating on the base support. The screw itself has to be located by a spring washer placed between the hexagonal socket head cap screw and a flat washer (→ **fig. 1**).

Fig. 1

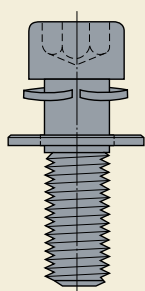

A hexagonal socket head cap screw combined with a flat washer and a spring washer provide improved attachment

Table 1

Permissible tolerances of the shaft diameter

Shaft diameter				Shaft tolerances	
over	incl.	over	incl.	high	low
mm		in		µm/in	
-	50	-	$1 \frac{15}{16}$	0	-76/-0.003
50	60	$1 \frac{15}{16}$	$2 \frac{15}{16}$	0	-102/-0.004

Table 2

Position and size of dowel pin holes for metric SKF ConCentra ball bearing units

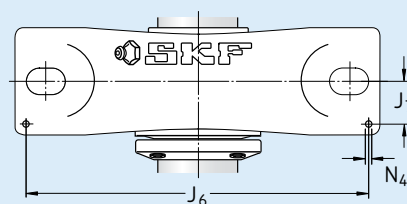

Bearing unit Designation	Dimensions		
	J ₆	J ₇	N ₄
-	mm		
SY 25 PF	120	13	2
SY 30 PF	142	14	2
SY 35 PF	146	15,5	4
SY 40 PF	161	17	4
SY 45 PF	173	17	4
SY 50 PF	187	19	5
SY 55 PF	201	21	5
SY 60 PF	222	21	5

Lubrication and maintenance

SKF ConCentra ball bearing units are filled with a premium, long life grease with a lithium-calcium thickener that has a NLGI class 2 consistency. This grease has good corrosion inhibiting properties, excellent water resistance and will provide long service life under normal operating conditions. The technical specifications for this standard grease are listed in **table 1** and enable maintenance-free operation, provided

- vibration levels are low
- the loads and speeds are moderate
- the normal operating temperature is between +40 and +55 °C.

Under more difficult operating conditions, SKF ConCentra ball bearing units may need to be relubricated in order to realize maximum service life. Therefore, all units are provided as standard with a grease nipple. The relubrication intervals depend on many related factors and can be estimated using the information provided in the following section.

Relubrication intervals

The relubrication intervals t_r for SKF ConCentra ball bearing units can be obtained from **diagram 1** as a function of

- the operating temperature, °C
- the rotational speed n , r/min
- the mean diameter of the insert bearing d_m , mm (→ **table 2**).

The relubrication intervals t_r are estimated values, valid for bearing units

- on horizontal shafts
- in stationary machines
- in a clean environment
- when the load ratio $C/P \geq 15$.

The relubrication interval is defined as the time period, at the end of which 90 % of the bearing units are still reliably lubricated. This represents the L_{10} grease life. When the L_{10} grease life is equivalent to or higher than the rating life of the SKF ConCentra ball bearing unit, the unit is considered to be lubricated for life and relubrication is not required.

The relubrication intervals obtained from **diagram 1** should be reduced accordingly if any of the following conditions exist

- on vertical shafts by 50 %
- at heavier loads, e.g. at load ratio $C/P = 8$, by roughly 50 %.

In severe, very dirty or damp environments more frequent relubrication might be necessary.

Vibrations have an influence on grease life but their effects can not be quantified exactly, except when there is a noticeable increase in operating temperature.

The grease life, obtained from **diagram 1**, shows an exponential correlation with temperatures ranging from +55 to +100 °C. Within that interval, when the temperature increases by 15 °C, grease life is reduced by approximately a factor of 2. Above +100 °C the grease life is reduced more dramatically, and in an uncontrolled way. Below +40 °C

Diagram 1

Service life of the grease fill in SKF ConCentra ball bearing units

as a function of

- the operating temperature, °C
- the rotational speed n , r/min
- the bearing mean diameter d_m , mm (→ **table 2**)

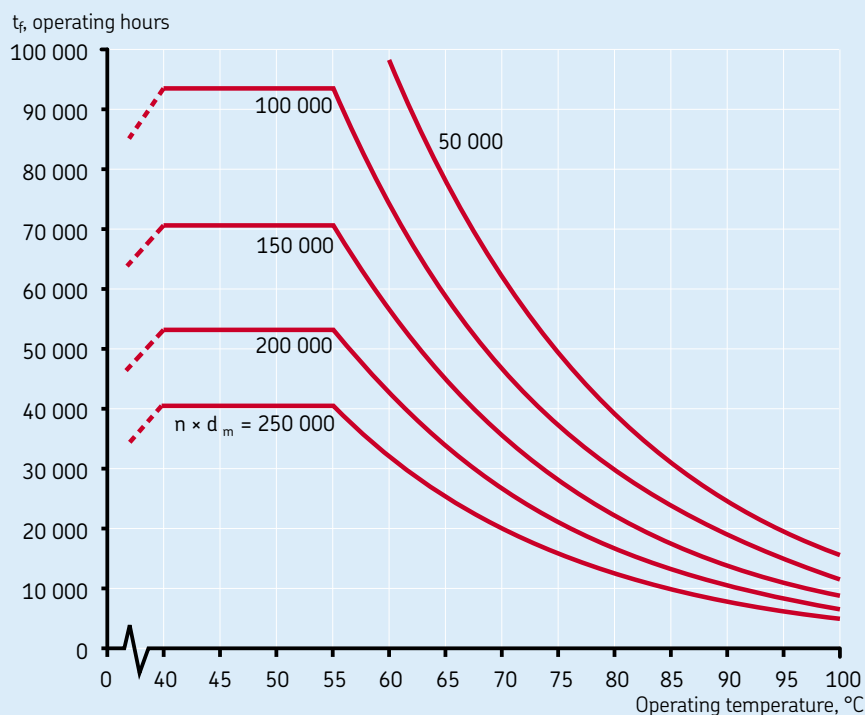

grease life drops gradually because of its diminished oil bleeding capabilities at lower temperatures. The correction factors for adverse operating conditions are only approximate. For additional information, contact the SKF application engineering service.

Relubrication procedure

When relubricating, grease should be applied while the bearing is rotating slowly until fresh grease escapes through the seals. Excessive pressure should be avoided, otherwise the seals may be damaged.

Greases for relubrication

To relubricate ConCentra ball bearing units, SKF recommends using its LGWA 2 grease, which is fully compatible with the original grease. SKF's multipurpose LGMT 2 and LGMT 3 greases can also be used for relubrication as they are also fully compatible with the original grease.

Storing SKF ConCentra ball bearing units

Because they are treated with a rust preventive compound, SKF ConCentra ball bearing units can be stored in their original unbroken package for a number of years provided the relative humidity of the storeroom does not exceed 60 % and there are no great fluctuations in temperature. When stored for an extended period, these ball bearing units may have a higher initial torque than a newer unit.

If not stored in their original packaging, SKF ConCentra ball bearing units should be well protected against corrosion and contamination.

Table 1

Grease fill of SKF ConCentra ball bearing units	
Properties	Technical specifications
Thickener	Lithium-calcium soap
Base oil	Mineral oil
NLGI class	2
Temperature range, °C ¹⁾	-20 to +120
Kinematic viscosity, mm ² /s at +40 °C	165
at +100 °C	15

¹⁾ The safe bearing operating temperature according to "The SKF traffic light concept", where the grease will function reliably, lies within +40 to +120 °C

Table 2

Mean diameter of the insert bearing, d _m		
SKF ConCentra ball bearing units for		Mean diameter
metric shafts	inch shafts	d _m
-		mm
SY 25 PF	SY 1. PF/AH	38,5
SY 30 PF	SY 1.3/16 PF/AH	46
SY 35 PF	SY 1.1/4 PF/AH	53,5
-	SY 1.3/8 PF/AH	53,5
-	SY 1.7/16 PF/AH	53,5
SY 40 PF	SY 1.1/2 PF/AH	60
SY 45 PF	SY 1.11/16 PF/AH	65
SY 50 PF	SY 1.15/16 PF/AH	70
SY 55 PF	SY 2.3/16 PF/AH	77,5
SY 60 PF	SY 2.7/16 PF/AH	85
-	SY 2.11/16 PF/AH	97,5
-	SY 2.15/16 PF/AH	102,5

Mounting and dismounting

To realize maximum performance and help prevent premature bearing damage, a clean work environment is essential. In addition, SKF recommends leaving the ConCentra ball bearing unit in its original package until immediately before mounting so that it will not be exposed to contaminants unnecessarily.

For convenience, a specially designed hexagonal key with a torque indicator is supplied with each SKF ConCentra unit so that the grub (set) screws are not under or over-tightened (→ **fig. 1**).

The following instructions are valid for SKF ConCentra ball bearing units with a plummer block housing that will be installed on commercial shafts.

Mounting

SKF ConCentra ball bearing units with a plummer (pillow) block housing

1. Remove any burrs on the shaft with emery cloth or a fine file (→ **step 1**). Wipe the shaft clean with a lint free cloth and check the shaft diameter (→ **table 1, page 11**).

2. Lubricate the shaft with a thin coat of light oil (→ **step 2**).
3. Mount any necessary components on the shaft, between the unit positions.
4. Clean the base of the unit and the support surface (→ **step 3**). Be sure the support surface is flat. If the unit elevation must be adjusted with shims, the shims must extend the full length and width of the base of the unit.
5. Slide the unit onto the shaft and into position – with the mounting side facing outward (→ **step 4**). Bolt the unit securely to the support.
6. Position the mounting collar so that a grub (set) screw is directly opposite the split in the adapter.
7. Hold the short end of the hexagonal key and tighten the screws a 1/2 turn each according to the mounting pattern (→ **fig. 2**). Continue to tighten the screws to finger tightness (→ **step 5**).
8. Turn the hexagonal key and start to tighten the grub screws by using the long end of the key point. Tighten a 1/4 turn on each screw according to the mounting pattern until the hexagonal key starts to flex.

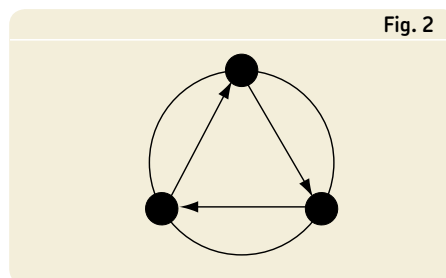

Fig. 2

9. Mount the supplied red torque indicator on the short end of the hexagonal key and tighten the screws until the hexagonal key comes in contact with the torque indicator (→ **step 6**). If another torque wrench is used, apply the recommended tightening torque listed in **table 1**.
10. Mount another unit at the opposite end of the shaft and repeat the procedures described under points 4 to 9.

Note: Do not use auxiliary equipment such as a hammer or a pipe to tighten the grub screws.

Reaching the recommended torque value for one of the grub (set) screws in the mounting collar

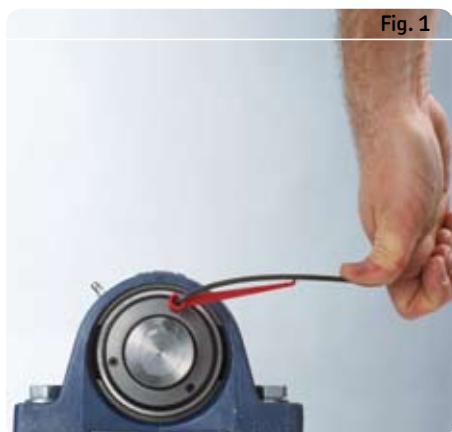
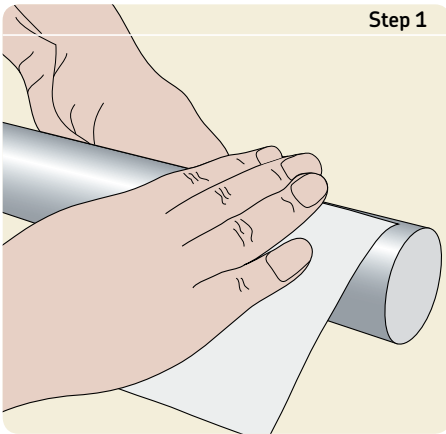
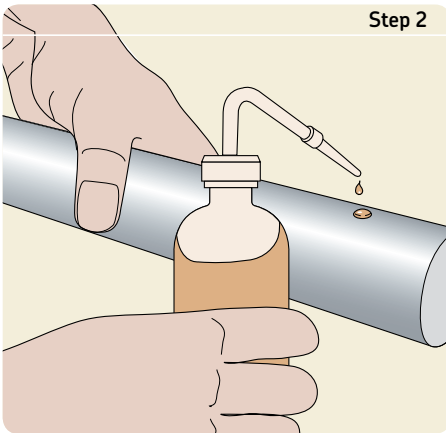

Fig. 1

Recommended tightening torque						
Shaft diameter				Screw size	Recommended tightening torque	
over	incl.	over	incl.		Nm	in.lbf
mm		in				
–	30	–	1 3/16	M 5	4,2	37
30	60	1 3/16	2 15/16	M 6	7,4	66



Step 1



Step 2

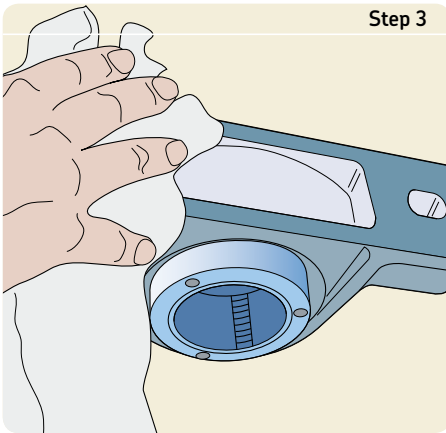

Step 3

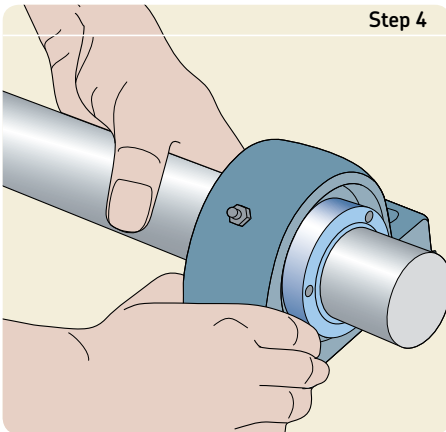

Step 4

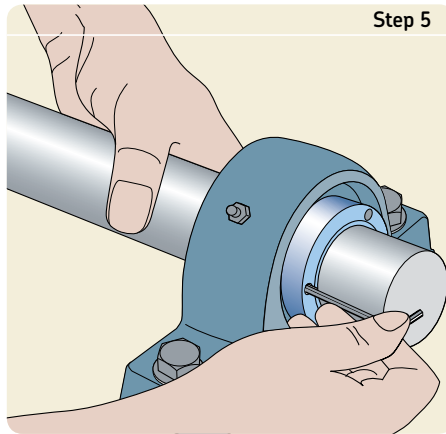

Step 5

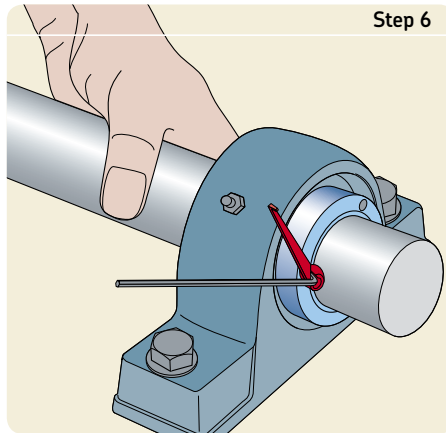

Step 6

Dismounting

1. It may be necessary to clean the shaft extensions with emery cloth to remove rust or repair surface damage.
2. Loosen the screws in the mounting ring on the first unit properly.
3. Loosen the attachment bolts on the second unit.
4. Lightly tap the mounting collar side of the first unit until the stepped sleeve releases the shaft.
5. Remove the attachment bolts of the first unit.
6. Withdraw the first unit from the shaft.
7. Retighten the attachment bolts of the second unit.
8. Loosen the screws in the mounting ring on the second unit properly.
9. Lightly tap the mounting collar side of the second unit until the stepped sleeve releases the shaft.
10. Remove the attachment bolts of the second unit.
11. Withdraw the second unit from the shaft.

Product data – general

Dimensions

The boundary dimensions of SKF ConCentra ball bearing units with plummer block housings conform to ISO 3228:1993, ANSI/ABMA 14-1995 and JIS B 1557-1995, where appropriate.

The units are dimensionally interchangeable with Y-bearing plummer block units in the SY series.

Tolerances

The tolerances for the shaft centre height H_1 (→ fig. 1) above the support surface are

- $\pm 0,25$ mm for metric units with a bore diameter up to and including 40 mm and for all inch size units
- $\pm 0,30$ mm for larger metric units.

The tolerance for the shaft centre height corresponds to the values specified in ISO 3228:1993.

For metric SKF ConCentra ball bearing units, the tolerances of the bearing outside diameter and the housing bore seating have been selected so that the bearing can not move (wander) in its seating, but can compensate for initial misalignment.

Bearings for inch shafts are mounted with a clearance fit in the housing. To prevent movement of the bearing in its seating (wandering) the outer ring is equipped with an anti-rotation pin (→ fig. 2).

Internal clearance

SKF ConCentra ball bearing units are produced as standard with radial internal clearance to Group 3 according to ISO 9628:1992. The clearance values are provided in **table 1** and are valid for unmounted bearing units under zero measuring load.

Speeds

SKF ConCentra ball bearing units are designed for applications with relatively high speeds. The speed ratings are only limited by the permissible circumferential speed of the seal lip on its counter surface. The limiting speeds are listed in the product tables.

Seals

SKF ConCentra ball bearing units are equipped, as standard, with two robust “Superagriseals”, each is inserted in a recess in the outer ring on both sides of the bearing. These seals consist of a pressed sheet steel washer with a acrylonitrile-butadiene rubber (NBR) lip vulcanized onto its inner surface. The steel washer forms a narrow gap with the cylindrical surface of the inner ring shoulder to provide efficient protection against coarse contaminants. To enhance the sealing effect without increasing friction, plain steel flingers are added outside the integral “Superagriseal” (→ fig. 3).

The seals are suitable for operating temperatures ranging from -40 to $+100$ °C and will withstand brief temperature peaks of up to $+120$ °C. However, the latter will have a detrimental effect on the service life of the grease fill.

Shaft centre height

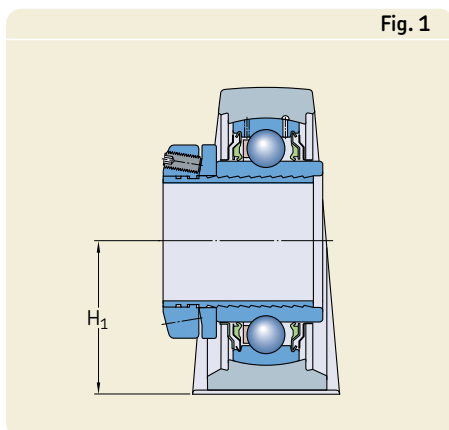

Fig. 1

Anti-rotation pin

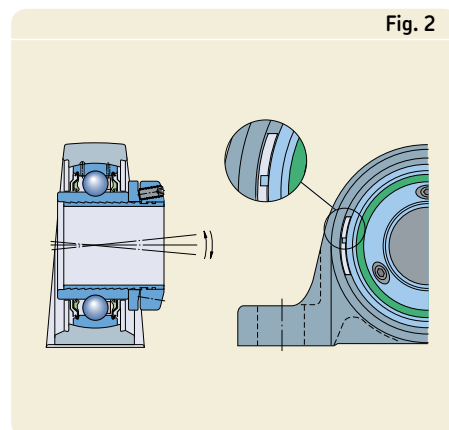

Fig. 2

Seal design

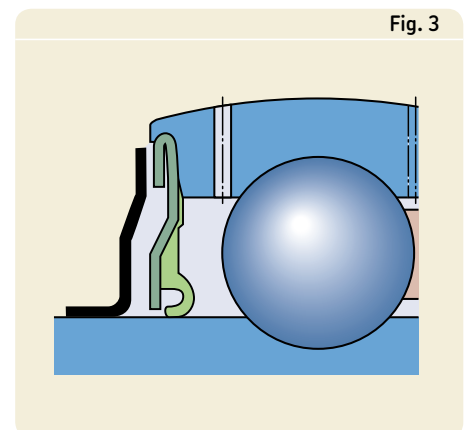

Fig. 3

Load carrying ability of the housings

The housings are made of grey cast iron EN-GJL HB195 according to EN 1561:1997 and can withstand the same dynamic and static loads as the SKF ConCentra insert bearing.

Equivalent loads

The loads acting on SKF ConCentra ball bearing units can be calculated according to the laws of mechanics. If the load F fulfils the requirements for the basic dynamic or static load ratings, i.e. the load is constant in magnitude and direction and acts radially, then $P = F$ and the load may be inserted directly in the equations. In all other cases equivalent bearing loads must be calculated.

Equivalent dynamic load

$$P = F_r \quad \text{when } F_a/F_r \leq e$$

$$P = 0,46 F_r + Y F_a \quad \text{when } F_a/F_r > e$$

where

P = equivalent dynamic bearing load, kN

F_r = actual radial bearing load, kN

F_a = actual axial bearing load, kN

Y = axial load factor for the bearing

e = limiting value for F_a/F_r

The factor Y and the limiting value e required to calculate the equivalent bearing load for SKF ConCentra ball bearing units depend on the relationship $f_0 F_a/C_0$, where f_0 is a calculation factor; in the case of SKF ConCentra units $f_0 = 14$ (→ table 2).

Equivalent static load

$$P_0 = 0,6 F_r + 0,5 F_a$$

If $P_0 < F_r$, $P_0 = F_r$ should be used.

Designations

The complete designation for an SKF ConCentra ball bearing unit consists of

- housing series identification
- size identification
- supplementary designations, identifying design, seal and other features.

Table 3 describes each part of the designation in the order that it appears.

Table 1

Radial internal clearance					
Bore diameter				Radial internal clearance	
d over	d incl.	d over	d incl.	min	max
mm	in	mm	in	µm	
–	30	–	1 3/16	23	41
30	40	1 3/16	1 1/2	28	46
40	50	1 1/2	2	30	51
50	–	2	2 7/16	38	61
–	–	2 7/16	2 15/16	46	71

Table 2

Calculation factors for SKF ConCentra ball bearing units		
Relative axial load	Calculation factors	
14 F_a/C_0	e	Y
0,31	0,31	1,75
0,48	0,33	1,62
0,86	0,36	1,46
1,6	0,41	1,3
3,1	0,46	1,14
6,2	0,54	1

Table 3

Designation scheme of SKF ConCentra ball bearing units				
Examples	SY 60 PF	60	PF	
	SY 1.3/4 PF/AH	1.3/4	PF	AH
Identification of housing and material				
SY	Plummer block housing according to ISO 3228:1993			
–	Grey cast iron			
Identification of size				
25	Bearing units for metric shafts: uncoded in millimetres			
	25 mm bore diameter			
	to			
60	60 mm bore diameter			
	Bearing units for inch shafts: uncoded in fractional inches			
1.	1 in = 25,400 mm bore diameter			
	to			
2.15/16	2 15/16 in = 74,612 mm bore diameter			
Identification of inserted bearing				
P	Ball bearing with SKF ConCentra stepped sleeve			
F	Ball bearing with Superagriseals and additional plain flingers on both sides			
Other features				
AH	Anti-rotation pin, solid feet and loose alignment torque			

SKF ConCentra ball bearing units with plummer block housing, for metric shafts
d 25 – 60 mm

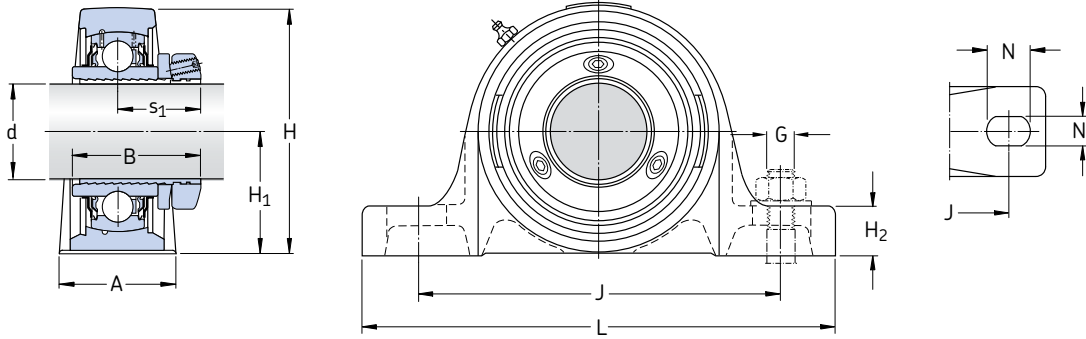

Shaft diameter d	Bearing unit Dimensions											Mass kg	Designation
	A	B	H	H ₁	H ₂	J	L	N	N ₁	G	s ₁		
mm	mm												-
25	36	41	70,5	36,5	16	102	130	19,5	11,5	10	29	0,85	SY 25 PF
30	40	45	82,5	42,9	17	117,5	152	23,5	14	12	31	1,20	SY 30 PF
35	45	47	93	47,6	19	126	160	21	14	12	32	1,55	SY 35 PF
40	48	51	99	49,2	19	135,5	175	24,5	14	12	34	2,05	SY 40 PF
45	48	52	107,5	54	21	143,5	187	22,5	14	12	35	2,25	SY 45 PF
50	54	54	114,4	57,2	22	157	203	26	18	16	36	2,70	SY 50 PF
55	60	57	126	63,5	24	171,5	219	27,5	18	16	37	3,85	SY 55 PF
60	60	59	138	69,9	26,5	190,5	240	29,5	18	16	38	5,00	SY 60 PF

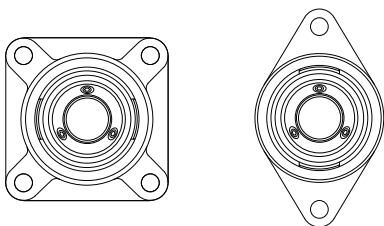

Flange units also available – please contact SKF for more information

Designations Complete unit	Components ¹⁾ Housing	Bearing	Basic load ratings dynamic static		Fatigue load limit P _u	Limiting speed	Grub screws	
			C	C ₀			Size	Tightening torque max
–			kN		kN	r/min	–	Nm
SY 25 PF	SY 505 M	YSP 205-2F	14	7,8	0,335	7 000	M 5	4,2
SY 30 PF	SY 506 M	YSP 206-2F	19,5	11,2	0,475	6 300	M 5	4,2
SY 35 PF	SY 507 M	YSP 207-2F	25,5	15,3	0,655	5 300	M 6	7,4
SY 40 PF	SY 508 M	YSP 208-2F	30,7	19	0,8	4 800	M 6	7,4
SY 45 PF	SY 509 M	YSP 209-2F	33,2	21,6	0,915	4 300	M 6	7,4
SY 50 PF	SY 510 M	YSP 210-2F	35,1	23,2	0,98	4 000	M 6	7,4
SY 55 PF	SY 511 M	YSP 211-2F	43,6	29	1,25	3 600	M 6	7,4
SY 60 PF	SY 512 M	YSP 212-2F	52,7	36	1,53	3 400	M 6	7,4

¹⁾ Only available as complete units

SKF ConCentra ball bearing units with plummer block housing, for inch shafts

d 1 – 2 15/16 in

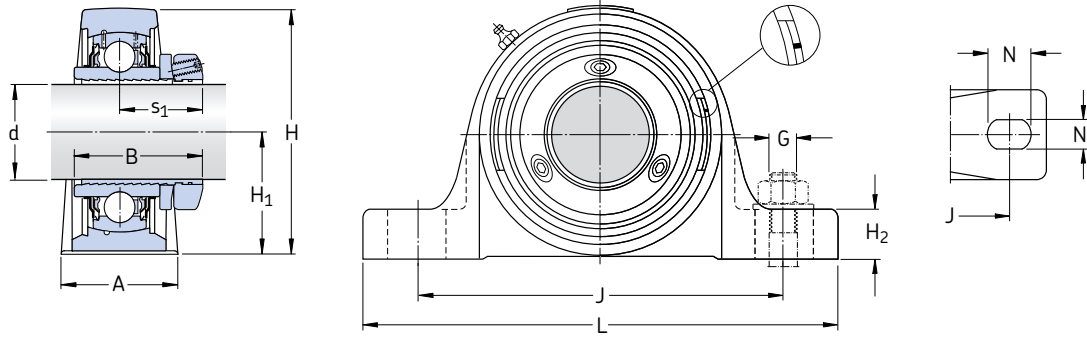

Shaft diameter d	Bearing unit Dimensions			H ₁	H ₂	J	L	N	N ₁	G	s ₁	Mass kg	Designation
	A	B	H										
in/mm	in/mm												
1 25,400	1 13/32 35,7	1 5/8 41,3	2 3/4 70	1 7/16 36,5	5/8 16	4 101,6	5 1/8 130,2	49/64 19,5	29/64 11,5	3/8 10	1 1/8 28,6	0,77	SY 1. PF/AH
1 3/16 30,1625	1 9/16 39,7	1 3/4 44,5	3 7/32 81,8	1 11/16 42,9	21/32 16,5	4 5/8 117,5	6 152,4	59/64 23,5	35/64 14	1/2 12	1 3/16 30,2	1,30	SY 1.3/16 PF/AH
1 1/4 31,750	1 25/32 45,2	1 7/8 47,6	3 21/32 93	1 7/8 47,6	3/4 19	5 127	6 5/16 160,3	53/64 21	35/64 14	1/2 12	1 1/4 31,8	1,65	SY 1.1/4 PF/AH
1 3/8 34,925	1 25/32 45,2	1 7/8 47,6	3 21/32 93	1 7/8 47,6	3/4 19	5 127	6 5/16 160,3	53/64 21	35/64 14	1/2 12	1 1/4 31,8	1,60	SY 1.3/8 PF/AH
1 7/16 36,5125	1 25/32 45,2	1 7/8 47,6	3 21/32 93	1 7/8 47,6	3/4 19	5 127	6 5/16 160,3	53/64 21	35/64 14	1/2 12	1 1/4 31,8	1,55	SY 1.7/16 PF/AH
1 1/2 38,100	1 57/64 48	2 1/16 52,4	3 29/32 99,2	1 15/16 49,2	3/4 19	5 11/32 135,7	6 57/64 175	31/32 24,5	35/64 14	1/2 12	1 5/16 33,3	1,95	SY 1.1/2 PF/AH
1 11/16 42,8625	1 29/32 48,4	2 50,8	4 7/32 107	2 1/8 54	13/16 20,6	5 21/32 143,6	7 3/8 187,3	57/64 22,7	35/64 14	1/2 12	1 3/8 34,9	2,40	SY 1.11/16 PF/AH
1 15/16 49,2125	2 1/8 54	2 1/8 54	4 1/2 114,3	2 1/4 57,2	7/8 22,2	6 3/16 157,2	8 203,2	1 25,4	45/64 18	5/8 16	1 3/8 34,9	2,85	SY 1.15/16 PF/AH
2 3/16 55,5625	2 3/8 60,3	2 1/4 57,2	5 127	2 1/2 63,5	15/16 23,8	6 3/4 171,5	8 5/8 219	1 3/32 27,5	45/64 18	5/8 16	1 7/16 36,5	3,65	SY 2.3/16 PF/AH
2 7/16 61,9125	2 23/64 60	2 5/16 58,7	5 1/2 139,7	2 3/4 69,9	1 1/32 26	7 1/2 190,5	9 7/16 240	1 1/8 28,6	45/64 18	5/8 16	1 1/2 38,1	5,00	SY 2.7/16 PF/AH
2 11/16 68,2625	2 9/16 65	2 3/8 60,3	5 7/8 149,2	3 76,2	1 1/8 28,6	8 203,2	10 15/64 260	1 3/8 35	7/8 22,2	3/4 20	1 1/2 38,1	6,10	SY 2.11/16 PF/AH
2 15/16 74,6125	2 13/16 71,4	2 1/2 63,5	6 17/32 166	3 1/4 82,6	1 9/32 32,5	8 1/2 215,9	10 63/64 279	1 3/8 35	7/8 22,2	3/4 20	1 5/8 41,3	7,25	SY 2.15/16 PF/AH

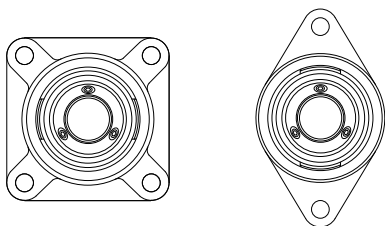

Flange units also available – please contact SKF for more information

Designations Complete unit	Components ¹⁾ Housing	Bearing	Basic load ratings		Fatigue load limit P _u	Limiting speed	Grub screws	
			dynamic C	static C ₀			Size	Tightening torque max
–			kN		kN	r/min	–	Nm
SY 1. PF/AH	SY 505 U/AH	YSP 205-100-2F/AH	14	7,8	0,335	7 000	M 5	4,2
SY 1.3/16 PF/AH	SY 506 U/AH	YSP 206-103-2F/AH	19,5	11,2	0,475	6 300	M 5	4,2
SY 1.1/4 PF/AH	SY 507 U/AH	YSP 207-104-2F/AH	25,5	15,3	0,655	5 300	M 6	7,4
SY 1.3/8 PF/AH	SY 507 U/AH	YSP 207-106-2F/AH	25,5	15,3	0,655	5 300	M 6	7,4
SY 1.7/16 PF/AH	SY 507 U/AH	YSP 207-107-2F/AH	25,5	15,3	0,655	5 300	M 6	7,4
SY 1.1/2 PF/AH	SY 508 U/AH	YSP 208-108-2F/AH	30,7	19	0,8	4 800	M 6	7,4
SY 1.11/16 PF/AH	SY 509 U/AH	YSP 209-111-2F/AH	33,2	21,6	0,915	4 300	M 6	7,4
SY 1.15/16 PF/AH	SY 510 U/AH	YSP 210-115-2F/AH	35,1	23,2	0,98	4 000	M 6	7,4
SY 2.3/16 PF/AH	SY 511 U/AH	YSP 211-203-2F/AH	43,6	29	1,25	3 600	M 6	7,4
SY 2.7/16 PF/AH	SY 512 U/AH	YSP 212-207-2F/AH	57	40	1,7	3 400	M 6	7,4
SY 2.11/16 PF/AH	SY 514 U/AH	YSP 214-211-2F/AH	62,4	45	1,86	3 000	M 6	7,4
SY 2.15/16 PF/AH	SY 515 U/AH	YSP 215-215-2F/AH	66,5	49	2,04	2 600	M 6	7,4

¹⁾ Only available as complete units

Other SKF bearing units

In addition to the SKF ConCentra ball bearing units listed in this brochure, the comprehensive SKF range includes additional ready-to-mount bearing units. These units are available as

- SKF ConCentra roller bearing units
- collar mounted bearing units
- ball bearing units/Y-bearing units
- two-bearing units.

SKF ConCentra roller bearing units

SKF ConCentra roller bearing units are based on SKF Explorer spherical roller bearings in the 222 series. The SYT plummer block units are available from stock for metric shafts from 35 to 75 mm. As standard, all plummer (pillow) block units are available for either the locating or non-locating position, either with contact or labyrinth seals.

As a complement to the standard metric line of products SKF ConCentra plummer block units and take-up units are available for 1 7/16 to 4 inch diameter shafts.

Collar mounted roller bearing units

SKF collar mounted roller bearing units are ready-to-mount, greased and sealed units that can accommodate shaft misalignment with respect to the housing. They consist of a bearing housing and a spherical roller bearing based on the 222 series. The bearing can be secured to the shaft with a grub (set) screw locking collar.

SKF collar mounted roller bearing units are available as plummer (pillow) block bearing units, flanged bearing units and take-up bearing units for 1 7/16 to 4 inch diameter shafts.

Ball bearing units/ Y-bearing units

Standard SKF ball bearing units are referred to as Y-bearing units. These ready-to-mount units can accommodate initial misalignment. The unit consists of a single row deep groove ball bearing with a convex sphered outside diameter and a bearing housing, with a correspondingly sphered but concave bore. Bearings and housings can be ordered separately.

SKF Y-bearing units are available as

- Y-bearing plummer (pillow) block units
- Y-bearing flanged units
- Y-bearing take-up units
- rubber cartridges.



A variety of housing materials including composites, grey cast iron, sheet steel and rubber cartridges are available. There is also a choice of bearing-to-shaft locking methods

- grub screw locking
- eccentric collar locking
- adapter sleeve locking.

Two-bearings units

SKF two-bearing units were originally designed for use on fan shafts with an overhung impeller. However, they are also used in other applications, e.g. centrifugal pumps, circular saws and grinding spindles. The advantages of two-bearing units are

- compact design
- high running accuracy
- quiet operation
- easy installation.

Several series with different bearing arrangements are available to meet different application requirements. The standard two-bearing unit contains two deep groove ball bearings.

Bearing housings

If standard SKF bearing units cannot meet the needs of your application regarding loads or sealing requirements, ask about other solutions. SKF has the most comprehensive assortment of standard bearing housings in the world. One of these housings, or a customized version of these housings together with the appropriate bearing is sure to meet your needs.

Detailed information about the products described above can be found in the

- “SKF Interactive Engineering Catalogue”, available on CD-ROM or online at www.skf.com
- product brochure 6103 “SKF ConCentra roller bearing units – true concentric locking, for fast and reliable mounting”
- catalogue 6001 “Y-bearings and Y-bearing units”
- brochure 5086 “Two-bearing units for fans – for economy and reliability”.



SKF – the knowledge engineering company

From the company that invented the self-aligning ball bearing 100 years ago, SKF has evolved into a knowledge engineering company that is able to draw on five platforms to create unique solutions for its customers. These platforms include bearings, bearing units and seals, of course, but extend to other areas including: lubricants and lubrication systems, critical for long bearing life in many applications; mechatronics that combine mechanical and electronics knowledge into systems for more effective linear motion and sensorized solutions; and a full range of services, from design and logistics support to conditioning monitoring and reliability systems.

Though the scope has broadened, SKF continues to maintain the world's leadership in the design, manufacture and marketing of rolling bearings, as well as complementary products such as radial seals. SKF also holds an increasingly important position in the market for linear motion products, high-precision aerospace bearings, machine tool spindles and plant maintenance services.

The SKF Group is globally certified both to ISO 14001, the international standard for environmental management, as well as OHSAS 18001, the health and safety management standard. Individual divisions have been approved for quality certification in accordance with either ISO 9000 or QS 9000.

With some 100 manufacturing sites worldwide and sales companies in 70 countries, SKF is a truly international corporation. In addition, our distributors and dealers in some 15 000 locations around the world, an e-business marketplace and a global distribution system put SKF close to customers for the supply of both products and services. In essence, SKF solutions are available wherever and whenever customers need them. Overall, the SKF brand and the corporation are stronger than ever. As the knowledge engineering company, we stand ready to serve you with world-class product competencies, intellectual resources, and the vision to help you succeed.



© Airbus – photo: efm company, H. Goussé

Evolving by-wire technology

SKF has a unique expertise in fast-growing by-wire technology, from fly-by-wire, to drive-by-wire, to work-by-wire. SKF pioneered practical fly-by-wire technology and is a close working partner with all aerospace industry leaders. As an example, virtually all aircraft of the Airbus design use SKF by-wire systems for cockpit flight control.

SKF is also a leader in automotive by-wire technology, and has partnered with automotive engineers to develop two concept cars, which employ SKF mechatronics for steering and braking. Further by-wire development has led SKF to produce an all-electric forklift truck, which uses mechatronics rather than hydraulics for all controls.

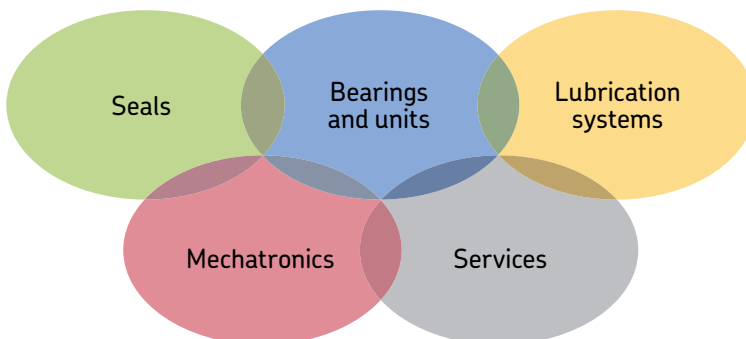



Harnessing wind power

The growing industry of wind-generated electric power provides a source of clean, green electricity. SKF is working closely with global industry leaders to develop efficient and trouble-free turbines, providing a wide range of large, highly specialized bearings and condition monitoring systems to extend equipment life of wind farms located in even the most remote and inhospitable environments.



Working in extreme environments

In frigid winters, especially in northern countries, extreme sub-zero temperatures can cause bearings in railway axleboxes to seize due to lubrication starvation. SKF created a new family of synthetic lubricants formulated to retain their lubrication viscosity even at these extreme temperatures. SKF knowledge enables manufacturers and end user customers to overcome the performance issues resulting from extreme temperatures, whether hot or cold. For example, SKF products are at work in diverse environments such as baking ovens and instant freezing in food processing plants.



Developing a cleaner cleaner

The electric motor and its bearings are the heart of many household appliances. SKF works closely with appliance manufacturers to improve their products' performance, cut costs, reduce weight, and reduce energy consumption. A recent example of this cooperation is a new generation of vacuum cleaners with substantially more suction. SKF knowledge in the area of small bearing technology is also applied to manufacturers of power tools and office equipment.



Maintaining a 350 km/h R&D lab

In addition to SKF's renowned research and development facilities in Europe and the United States, Formula One car racing provides a unique environment for SKF to push the limits of bearing technology. For over 50 years, SKF products, engineering and knowledge have helped make Scuderia Ferrari a formidable force in F1 racing. (The average racing Ferrari utilizes more than 150 SKF components.) Lessons learned here are applied to the products we provide to auto-makers and the aftermarket worldwide.



Delivering Asset Efficiency Optimization

Through SKF Reliability Systems, SKF provides a comprehensive range of asset efficiency products and services, from condition monitoring hardware and software to maintenance strategies, engineering assistance and machine reliability programs. To optimize efficiency and boost productivity, some industrial facilities opt for an Integrated Maintenance Solution, in which SKF delivers all services under one fixed-fee, performance-based contract.



Planning for sustainable growth

By their very nature, bearings make a positive contribution to the natural environment, enabling machinery to operate more efficiently, consume less power, and require less lubrication. By raising the performance bar for our own products, SKF is enabling a new generation of high-efficiency products and equipment. With an eye to the future and the world we will leave to our children, the SKF Group policy on environment, health and safety, as well as the manufacturing techniques, are planned and implemented to help protect and preserve the earth's limited natural resources. We remain committed to sustainable, environmentally responsible growth.



SKF is a registered trademark of the SKF Group.

© SKF Group 2006

The contents of this publication are the copyright of the publisher and may not be reproduced (even extracts) unless permission is granted. Every care has been taken to ensure the accuracy of the information contained in this publication but no liability can be accepted for any loss or damage whether direct, indirect or consequential arising out of the use of the information contained herein.

Publication **6107/I EN** · June 2006

Printed in Sweden on environmentally friendly paper.

skf.com