

# POWERBUILT®

COMPONENTS  
COMPOSANTS  
COMPONENTES  
#691598  
#691589

**6 IN. BENCH GRINDER INSTRUCTION MANUAL**

**6 IN. BENCH GRINDER WITH WORKLIGHT INSTRUCTION MANUAL**

**MANUEL DE L'UTILISATEUR POUR MEULEUSE D'ETABLI DE 6 PO**

**MANUEL DE L'UTILISATEUR POUR MEULEUSE D'ETABLI DE 6 PO AVEC LAMPE DE TRAVAIL**

**MANUAL DE INSTRUCCIONES PARA LA ESMERILADORA DE BANCO DE 6 PULG.**

**MANUAL DE INSTRUCCIONES PARA LA ESMERILADORA DE BANCO DE 6 PULG. CON LUZ DE TRABAJO**



691598



691589

THIS MANUAL CONTAINS IMPORTANT INFORMATION REGARDING SAFETY, OPERATION, MAINTENANCE AND STORAGE OF THIS PRODUCT. BEFORE USE, READ CAREFULLY AND UNDERSTAND ALL CAUTIONS, WARNINGS, INSTRUCTIONS AND PRODUCT LABELS. FAILURE TO DO SO COULD RESULT IN SERIOUS PERSONAL INJURY AND/OR PROPERTY DAMAGE.

CE MANUEL CONTIENT DES INFORMATIONS IMPORTANTES CONCERNANT LA SÉCURITÉ, LE FONCTIONNEMENT ET LE REMISAGE DE CE PRODUIT. LIRE, ÉTUDIER ET VEILLER À BIEN COMPRENDRE TOUTES LES MISES EN GARDE ET INSTRUCTIONS ET AUTOCOLLANTS APPOSÉS SUR LE PRODUIT AVANT DE L'UTILISER. NE PAS RESPECTER CES INSTRUCTIONS POURRAIT ENTRAÎNER DES BLESSURES ET/OU DES DOMMAGES MATÉRIELS.

ESTE MANUAL CONTIENE INFORMACIÓN IMPORTANTE SOBRE LA SEGURIDAD, OPERACIÓN, MANTENIMIENTO Y ALMACENAMIENTO DE ESTE PRODUCTO. ANTES DE USARLO, LEA Y COMPRENDA TODAS LAS PRECAUCIONES, ADVERTENCIAS, INSTRUCCIONES Y ETIQUETAS DEL PRODUCTO. DE LO CONTRARIO PODRÍA SUFRIR LESIONES GRAVES O CAUSAR DAÑOS MATERIALES.

IF YOU SHOULD HAVE ANY QUESTIONS OR EXPERIENCE A PROBLEM WITH YOUR ALLTRADE PRODUCT, DO NOT RETURN THIS PRODUCT TO THE STORE. PLEASE CALL OUR CUSTOMER SERVICE DEPARTMENT AT **1-800-423-3598**. BEFORE YOU CALL, HAVE THE FOLLOWING INFORMATION AVAILABLE: MODEL No., DATE PURCHASED AND STORE LOCATION. AN ALLTRADE REPRESENTATIVE CAN RESOLVE YOUR PROBLEM OVER THE PHONE. IF YOU WOULD LIKE TO MAKE A SUGGESTION OR COMMENT, GIVE US A CALL OR EMAIL US AT: [INFO@ALLTRADETOOLS.COM](mailto:INFO@ALLTRADETOOLS.COM). YOUR FEEDBACK IS VITAL TO US.

POUR TOUTE QUESTION OU EN CAS DE PROBLÈME AVEC LE PRODUIT ALLTRADE, NE PAS LE RETOURNER AU MAGASIN OÙ IL A ÉTÉ ACHETÉ. APPELER LE SERVICE APRÈS-VENTE AU **1-800-423-3598**. AVANT D'APPELER, VEILLER À SE PROCURER LES INFORMATIONS SUIVANTES : No. DE MODÈLE, DATE DE L'ACHAT ET ADRESSE DU MAGASIN. UN REPRÉSENTANT D'ALLTRADE PEUT RÉSOUDRE VOTRE PROBLÈME PAR TÉLÉPHONE. POUR TOUT COMMENTAIRE OU SUGGESTION, N'HÉSITÉZ PAS À NOUS APPELER OU NOUS CONTACTER PAR COURRIEL À L'ADRESSE : [INFO@ALLTRADETOOLS.COM](mailto:INFO@ALLTRADETOOLS.COM). VOS COMMENTAIRES NOUS SONT EXTRÊMEMENT PRÉCIEUX.

SI TIENE DUDAS O SURGEN PROBLEMAS CON SU PRODUCTO ALLTRADE, NO LO DEVUELVA A LA TIENDA LLAME A NUESTRO DEPARTAMENTO DE SERVICIO AL CLIENTE AL **1-800-423-3598**. ANTES DE LLAMAR, TENGA A MANO LA SIGUIENTE INFORMACIÓN: No. DE MODELO, FECHA DE COMPRA Y DIRECCIÓN DE LA TIENDA. UN REPRESENTANTE DE ALLTRADE PUEDE RESOLVER SU PROBLEMA POR TELÉFONO. SI DESEA HACER ALGUNA SUGERENCIA O COMENTARIO, LLÁMENOS O ENVÍENOS UN MENSAJE DE CORREO ELECTRÓNICO A: [INFO@ALLTRADETOOLS.COM](mailto:INFO@ALLTRADETOOLS.COM). SUS COMENTARIOS SON FUNDAMENTALES PARA NOSOTROS.

**POWERBUILT®**  
Serious Tools For Serious Work®

1431 Via Plata  
Long Beach, CA 90810-1462 USA  
Made in China/Fabriqu  en Chine/  
Impreso en China

 2009, Alltrade Tools LLC  
[www.alltradetools.com](http://www.alltradetools.com)

## TABLE OF CONTENTS

<b>CONGRATULATIONS!</b>	2
<b>INTENDED USE</b>	2
<b>SECTION ONE</b>	
GENERAL SAFETY RULES – FOR ALL ELECTRIC POWER TOOLS	2-6
RECOGNIZE SAFETY SYMBOLS, WORDS AND LABELS	2-3
IMPORTANT SAFEGUARDS	3
WORK AREA	4
ELECTRICAL SAFETY	4
PERSONAL SAFETY	5
TOOL USE AND CARE	5-6
SERVICE	6
<b>SECTION TWO</b>	
SAFETY RULES FOR BENCH GRINDERS	6-10
GROUNDING INSTRUCTIONS	9-10
EXTENSION CORD STORAGE	10
SYMBOLS	10
<b>SECTION THREE</b>	
FUNCTIONAL DESCRIPTION	11
ASSEMBLY INSTRUCTIONS	12-14
INSTALLING THE TOOL RESTS	12-14
INSTALLING THE SPARK DEFLECTORS	14
INSTALLING THE EYE SHIELDS	14
OPERATING THE BENCH GRINDER	15-16
OPERATING THE ON/OFF SWITCH	15
GRINDER OPERATIONS	15-16
<b>SECTION FOUR</b>	
MAINTENANCE AND CLEANING	16-19
ACCESSORIES	19-20
SPECIFICATIONS	20
OTHER CONSUMER DO-IT-YOURSELF (DIY) TOOLS	20
<b>SECTION FIVE</b>	
1 YEAR LIMITED WARRANTY	21-22

## CONGRATULATIONS!

Thanks for choosing this product. At Alltrade, our aim is to provide you with quality products at an affordable price, and we want you to be totally satisfied with your product and our Customer Service. If any help and advice is needed, please contact us at 1-800-423-3598. Properly cared for, this tool will give you many years of satisfaction.

## INTENDED USE

This tool is intended for consumer use only. This tool is not designed for professional use. The power cord should only be used in approved electrical outlets as described in this manual.

## GENERAL SAFETY RULES – FOR ALL ELECTRIC POWER TOOLS

**⚠ WARNING** READ AND UNDERSTAND ALL INSTRUCTIONS. Failure to follow all instructions listed below may result in electric shock, fire and/or serious personal injury.

## SAVE THESE INSTRUCTIONS FOR FUTURE REFERENCE.

## RECOGNIZE SAFETY SYMBOLS, WORDS AND LABELS

The safety instructions provided in this manual are not intended to cover all possible conditions and practices that may occur when operating, maintaining and cleaning power tools.

Always use common sense and pay particular attention to all the **DANGER**, **WARNING**, **CAUTION** and **NOTE** statements of this manual.



This is the safety alert symbol. It is used to alert you to potential personal injury hazards. Obey all safety messages that follow this symbol to avoid possible injury or death.

**⚠ DANGER**

**DANGER** indicates an imminently hazardous situation which, if not avoided, will result in death or serious injury.

**⚠ WARNING**

**WARNING** indicates a potentially hazardous situation which, if not avoided, could result in death or serious injury.

**⚠ CAUTION**

**CAUTION** indicates a potentially hazardous situation which, if not avoided, may result in minor or moderate injury.

**CAUTION**

**CAUTION** used without the safety alert symbol indicates a potentially hazardous situation which, if not avoided, may result in property damage.

**NOTE**

**NOTE** provides additional information that is useful for proper use and maintenance of this tool. If a NOTE is indicated make sure it is fully understood.

**IMPORTANT SAFEGUARDS**

**⚠ DANGER**

People with electronic devices, such as pacemakers, should consult their physician(s) before using this product. Operation of electrical equipment in close proximity to a heart pacemaker could cause interference or failure of the pacemaker.

**WARNING:** Some dust created by power sanding, sawing, grinding, drilling and other construction activities contains chemicals known to the State of California to cause cancer, birth defects or other reproductive harm.

Some examples of these chemicals are:

- Lead from lead-based paints.
- Crystalline silica from bricks and cement and other masonry products, and arsenic and chromium from chemically-treated lumber.

Your risk from these exposures varies, depending on how often you do this type of work. To reduce your exposure to these chemicals: work in a well ventilated area, and work with approved safety equipment, such as dust masks that are specially designed to filter out microscopic particles.

**WARNING:** This product contains chemicals known to the State of California to cause cancer and birth defects or other reproductive harm.

**WORK AREA**

**⚠ WARNING**

**Keep your work area clean and well lit.** Cluttered work benches and dark work areas may cause accidents or injury.

**Do not operate power tools in explosive areas, such as in the presence of flammable liquids, gases or dust.** Power tools create sparks which may ignite the dust or fumes.

**Keep bystanders, children and visitors away while operating a power tool.** Distractions can cause you to lose control.

**ELECTRICAL SAFETY**

**⚠ WARNING**

**Grounded tools must be plugged into an outlet properly installed and grounded in accordance with all codes and ordinances. Never remove the grounding prong or modify the plug in any way. Do not use any adaptor plugs. Check with a qualified electrician if you are in doubt as to whether the outlet is properly grounded. If the tools should electrically malfunction or break down, grounding provides a low resistance path to carry electricity away from the user.**

**Avoid body contact with grounded surfaces such as pipes, radiators, ranges and refrigerators.** There is an increased risk of electric shock if your body is grounded.

**Do not expose power tools to rain or wet conditions.** Water entering a power tool will increase the risk of electric shock.

**Do not abuse the cord. Never use the cord to carry the tool or pull the plug from an outlet. Keep the cord away from heat, oil, sharp edges, or moving parts. Replace damaged cords immediately.** Damaged cords increase the risk of electric shock.

**When operating the power tool outside, use an outdoor extension cord marked "W-A" or "W."** These cords are rated for outdoor use and reduce the risk of electric shock.

**Make sure the extension cord being used is in good condition.** If there are any cut or nicks (no matter how deep) in the insulation, **DO NOT** use that cord. Also, make sure the extension cord is heavy enough to carry the current needed by the saw (see ELECTRICAL REQUIREMENTS). **DO NOT** use small "around-the-house" lamp extension cords. These cords can easily overheat and/or catch fire when used with power tools.

## PERSONAL SAFETY

### WARNING

**Stay alert, watch what you are doing, and use common sense when operating a power tool. Do not use tool while tired or under the influence of drugs, alcohol or medication.** A moment of inattention while operating power tools may result in serious personal injury.

**Make workshop kid proof with padlocks, master switches, or by removing starter keys.**

**Dress properly. Do not wear loose clothing or jewelry. Contain long hair. Keep your hair, clothing, and gloves away from moving parts.** Loose clothes, jewelry or long hair can be caught in moving parts.

**Avoid accidental starting. Be sure switch is off before plugging in.** Carrying tools with your finger on the switch or plugging in tools that have the switch on invites accidents.

**Never tool running unattended. Turn power Off.**

**Remove adjusting keys or wrenches before turning the tool "ON".** A wrench or a key that is left attached to a rotating part of the tool may result in personal injury.

**Do not overreach. Keep proper footing and balance at all times.** Proper footing and balance enable better control of the tool in unexpected situations.

**Use safety equipment. Always wear eye protection. Everyday eyeglasses only have impact resistant lenses, they are NOT safety glasses.** Dust mask, non-skid safety shoes, hard hat, or hearing protection must be used for appropriate conditions.

## TOOL USE AND CARE

### CAUTION

**Use clamps or other practical ways to secure and support the workpiece to a stable platform.** Holding the work by hand or against your body is unstable and may lead to loss of control.

**Never stand on tool.** Serious injury could occur if the tool is tipped or if the cutting tool is unintentionally contacted.

**Do not force tool. Use the correct tool for your application.** The correct tool will do the job better and safer at the rate for which it is designed.

**Do not use tool if the power switch does not turn it "ON" or "OFF".** Any tool that cannot be controlled with the power switch is dangerous and must be replaced.

### CAUTION

**Disconnect the power cord plug from the power source before making any adjustments, changing accessories or storing the tool.** Such preventive safety measures reduce the risk of starting the tool accidentally.

**Store idle tools out of reach of children and other untrained persons.** Tools are dangerous in the hands of untrained users.

**Maintain tools with care. Keep cutting tools sharp and clean.** Properly maintained tools with a sharp cutting edge are less likely to bind and are easier to control. Follow instructions for changing accessories.

**Check for misalignment or binding of moving parts, breakage of parts, and any other condition that may affect the tool's operation. If damaged, have the tool serviced before using.** Many accidents are caused by poorly maintained tools.

**Use only accessories that are recommended by the manufacturer for your model.** Accessories that may be suitable for one tool may become hazardous when used on another tool. Consult the owner's manual for recommended accessories.

## SERVICE

### CAUTION

**Tool service must be performed only by qualified repair personnel.** Service or maintenance by unqualified personnel could result in a risk of injury.

**When servicing a tool, use only identical replacement parts. Follow instructions in the Maintenance section of this manual.** Use of unauthorized parts or failure to follow Maintenance Instructions may create a risk of shock or injury.

## IMPORTANT SAFETY RULES FOR BENCH GRINDERS

### WARNING

**Always wear protective eyewear and/or appropriate dust filters and respirator when using this tool.**

**Keep guards in place and in working order.**

**Frequently clean grinding dust from beneath grinder.**

**DO NOT operate this bench grinder until it is completely assembled according to the instructions in this manual.** Failure to adhere to these instructions could result in serious and/or permanent injury.

**Obtain advice from a qualified individual if you are not completely sure how to use the bench grinder.**

**⚠ WARNING**

**Follow all wiring codes.** Use only properly grounded three-hole grounded receptacles. DO NOT cut the third prong off the power cord. When using an extension cord, use only UL Listed extension cords with minimum 16 AWG wiring and a maximum length of 25 feet. See ELECTRICAL SAFETY section in this manual.

**Keep bystanders, children, and visitors at a safe distance from the bench grinder while it is in operation.** Distractions can cause inadvertent misuse resulting in possible injury to the bystanders or to the operator.

**Always use the provided wheel flanges to mount grinding wheels on the grinder shaft to prevent wheel damage or separation.** Separation can result in fragments flying off the wheel at high speeds possibly causing severe injuries.

**Use only grinding wheels and metal brushes that are designed for the speed of this grinder.** Unsuitable grinding wheels can separate throwing fragments outward at high speeds possibly causing severe injuries.

**Never attempt to use a grinding wheel or metal brush with an arbor hole different from the motor shaft on the grinder.**

**Do not overtighten the arbor nut.** Excessive tightening can cause the wheel to fracture and possibly break apart during use and throw pieces outward at high speeds.

**Do not use a grinding wheel that vibrates.** Visually inspect the grinding wheels and dress them as necessary or replace them immediately. If the vibration still exists, check the bearings on the motor shaft and repair or replace them as soon as possible. EXCESSIVE VIBRATION can cause wheel separation.

**Replace a cracked wheel immediately.**

**Adjust the eye shields so they are close to the wheels.** Re-adjust the shields as the wheel wears down. Flying sparks are dangerous and cause fires and/or explosions if they come in contact with flammable materials or liquids.

**Make sure the eye shields are in place and properly adjusted and secured at all times the grinder is in use.**

**Adjust the tool rests before each use.** Adjust distance between wheel and Tool Rest to maintain 1/8 inch or less separation. The amount of separation is to be recommended by the manufacturer, but shall not be more than 1/8 inch (3.18 mm).. The tool rests should always be tightened to prevent shifting in positions. They should be re-adjusted, as needed, as the grinding wheel wears down. If not properly adjusted, the work piece can be inadvertently drawn into the grinding wheel causing damage to it or possible severe injury to the operator.

**⚠ WARNING**

**DO NOT stand directly in front of the grinder when it is first turned on.** Loose fragments could fly off at high speeds possibly causing injury.

**NEVER engage a work piece to a cold grinding stone.** A cold grinding stone has a tendency to chip. Allow the grinder to run for an entire minute before applying the work piece to the grinding stone.

**NEVER start the bench grinder with the work piece against the grinding wheel.** The work piece can be drawn into the grinding wheel causing it to fragment resulting in damage to the grinder and/or serious injury to the operator.

**Thoroughly clean the grinder before changing types of work pieces.** Combining wood and metal dust can result in an explosion or fire. DO NOT GRIND OR POLISH WORK PIECES MADE OF MAGNESIUM. The magnesium could ignite resulting in a very intense fire that could cause severe burns to the operator and/or seriously damage the bench grinder.

**NEVER perform grinding operations near flammable gas or liquids.** The resulting fire and/or explosion could cause permanent serious injuries to the operator and damage to the grinder and surrounding work area.

**Avoid awkward positions for both hands and work pieces. A sudden slip could draw fingers into the grinding wheel causing injury.** Always keep hands, arms and fingers away from the grind wheel surface. Severe injury could result.

**Hold the piece firmly against the grinding wheel.** A loose grip can cause loss of control of the work piece resulting in severe injuries or damage to the bench grinder.

**Always make contact with the face of the grinding stones.** Grinding objects on the side of the grinding stones can cause the stones to fragment resulting in fragments being thrown from the wheel at high speeds. Serious injury could result.

**Never apply a coolant directly to the work piece while it is in contact with the grinding stone.** Coolant can weaken the makeup of the grinding stones causing them to fail. Dip the work piece in water to cool it.

**DO NOT touch the ground portion of the work piece until it has properly cooled.** Touching HOT surfaces can cause injury.

**NEVER perform layout or assembly to work pieces in front of the grinder while it is still running.** A sudden slip could bring hands in contact with the moving parts of the bench grinder resulting in injury to the operator.

**⚠ WARNING**

Turn the ON/OFF switch on the grinder to the “OFF” position and unplug the power cord from the electrical receptacle when the grinding operations are finished. Thoroughly clean the area surrounding the bench grinder making it ready for the next use.

Secure the electrical power cord to prevent unauthorized use of the bench grinder and/or to prevent children from accidentally turning it on.

Additional information about the proper use of bench grinders is available from the Power Tool Institute, 1300 Sumner Avenue, Cleveland, OH 44115-2851 ([www.powertoolinstitute.com](http://www.powertoolinstitute.com)). Information is also available from the National Safety Council, 1121 Spring Lake Drive, Itasca, IL 60143-3201. Additionally, you can refer to the American National Standards Institute (ANSI) 01.1 Safety Requirements for Woodworking Machines and the U.S. Department of Labor OSHA 1910.213 Regulations.

**GROUNDING INSTRUCTIONS**

The electrical power source for this bench grinder MUST be grounded in order prevent possible electric shock or even death should the tool malfunction or breakdown. Grounding provides a path of least resistance for electric current thus reducing the risk of electrical shock. The power source must also use a minimum 20A service and not used if other power tools on the same circuit are in use.

This bench grinder is equipped with a grounded 3-wire power cord with a 3-prong plug. If the power cord will not fit into the wall plug, an approved adapter can be used as long as it is connected to the center screw in the wall plate. **Never modify the electrical plug** by cutting off the grounding prong so it will fit into unapproved, un-grounded electrical receptacles. See Figure 1.

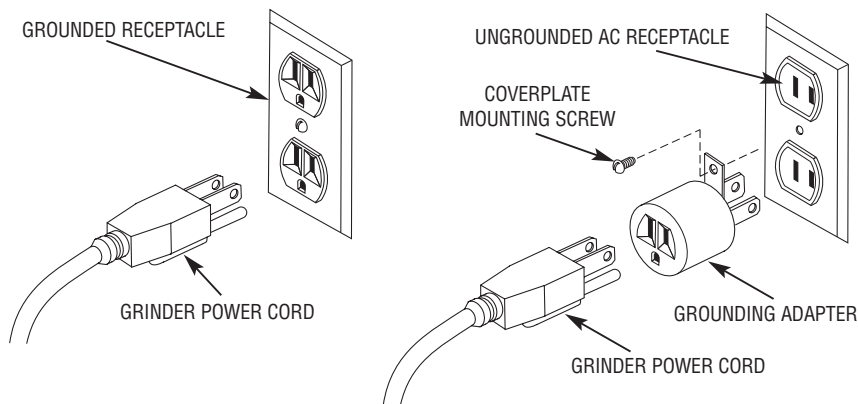

FIGURE 1. CONNECTING THE BENCH GRINDER TO THE AC POWER RECEPTACLE

If you have questions about hooking up the bench grinder, contact a certified electrical contractor to install the proper circuitry acceptable for this and other power tools you use. Repair or replace any damaged electrical wiring **IMMEDIATELY**.

**EXTENSION CORD USAGE**

Extension cords are not recommended for use with this bench grinder. Extension cords, if used, must be properly grounded with a 3-prong plug on one and a 3-hole receptacle on the other. **DO NOT use grounding adapters with an extension cord.** Extension cords must be UL listed and use a minimum of 16 A.W.G. wiring. Extension cords should never exceed 25 feet in length. Extension cords, that are too long, cause a voltage drop over the extra distance causing the grinder motor to run slower with the possibility of causing damage to the motor. Using extension cords with smaller than the recommended wire gauge run the risk of getting too hot, melting, and/or causing fires. See table, “**Extension Cord Specifications**”, on page 20.

**SYMBOLS**

**IMPORTANT:** Some of the following symbols may be used on your tool. Please study them and learn their meaning. Proper interpretation of these symbols will allow you to operate the tool better and safer.

SYMBOL	NAME	EXPLANATION
V	Volts	Voltage (Potential)
A	Amperes	Current
Hz	Hertz	Frequency (Cycles per Second)
W	Watt	Power
Kg	Kilograms	Weight
~	Alternating Current	Type of Current
≡	Direct Current	Type of Current
⎓	Alternating or Direct Current	Type of Current
⊕	Earthing Terminal	Grounding Terminal
⊞	Class II Construction	Denotes Double Insulation
min	Minutes	Time
s	Seconds	Time
φ	Diameter	Size of Drill Bits, Grinding Wheels, etc.
$n_0$	No load speed	No-load Rotational Speed
.../min	Revolutions per Minute	Revolutions, Surface Speed, Strokes, etc. per Minute
1,2,3, ...	Ring Selector Settings	Speed, Torque or Position Settings

## FUNCTIONAL DESCRIPTION

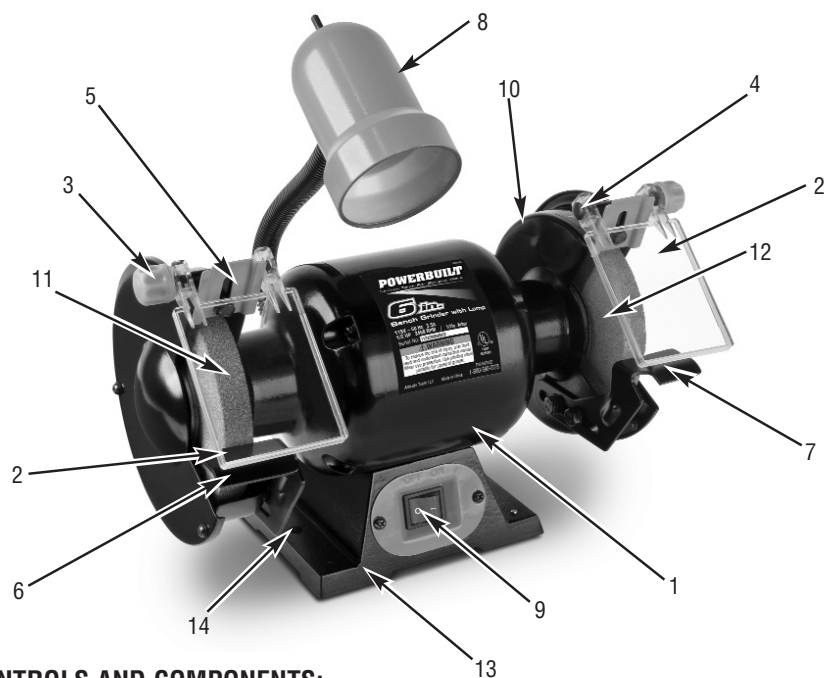

### CONTROLS AND COMPONENTS:

1. Grinder Motor Housing
2. Eye Shield (2)
3. Eye Shield Locking Knob(2)
4. Eye Shield Mounting Bolt and Washer (2)
5. Spark Deflector (2)
6. Left Side Tool Rest
7. Right Side Tool Rest with V-groove
8. Flexible Work Light (691589 only)
9. On/Off Switch
10. Wheel Guard (2)
11. Grinding Wheel (36 Grit)
12. Grinding Wheel (60 Grit)
13. Base
14. Mounting Holes

## ASSEMBLY INSTRUCTIONS

**⚠ WARNING** Disconnect the power plug from the AC power source before any assembly, adjustments, or adding/removing accessories. Following this preventative step reduces the risk of the drill coming on accidentally and the risk of damage to the work piece and injury to the operator.

**INSPECTION:** Carefully inspect each individual part of the bench grinder to ensure there are no cracked, broken, or bent components needed for a safe installation.

1. Carefully choose a location for the bench grinder. If mounted on a workbench, ensure there is adequate room all around the grinder for safe operation. The area must be level and clear of other power tools and/or power tool cords that could interfere with operation of the bench grinder.
2. If the bench grinder is installed on a universal tool stand (available at larger hardware stores), ensure there is plenty of unobstructed space around the grinder as not to interfere with safe operation on the tool.
3. The bench grinder should be installed in a place that is away from outside elements and close to an approved power receptacle so that an extension cord will not be needed. Should an extension cord be needed, refer to Page 20 in this manual for choosing the proper length and wire gauge needed for safe operation of the bench grinder.
4. Do not assemble and/or use the grinder in an area that may be contaminated with oily rags. Keep flammable materials such as gasoline, paint thinner or solvents. Sparks from normal grinding operations can ignite these compounds resulting in moderate to severe burns to the operator.
5. Carefully inspect the grinding wheels to ensure they were not damaged during shipment. Fractured grinding wheels can shatter during grinding operations and throw off pieces at high speeds. **Failure to adhere to these cautions can cause severe injury including blindness or even death to the operator.**

### INSTALLING THE TOOL RESTS

**⚠ WARNING** To reduce the risk of injury, never use a bench grinder on which the tool rest has not been fitted or where the tool rest has not been correctly adjusted.

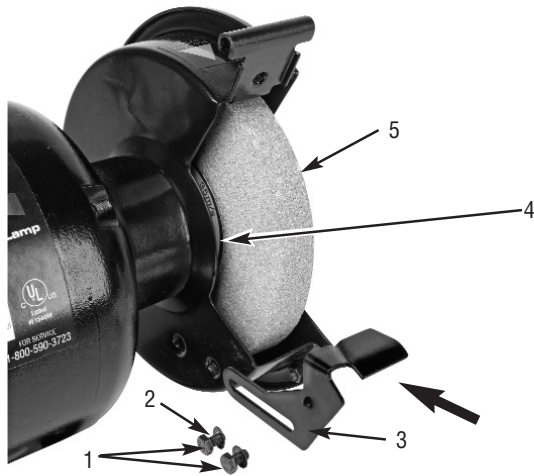

FIGURE 2. INSTALLING THE R/H TOOL REST

When installing the Tool Rests on the bench grinder, NOTE there is a Left Tool Rest and a Right Tool Rest. The tool rest shelf ALWAYS points away from the motor and the two different tool rests cannot be installed on the wrong side. See Figure 2.

1. Remove the two mounting bolts (1) and washers (2) from the parts bag.
2. Install the Tool Rests (3) to the wheel guards as shown in Figure 2.
3. Insert the mounting bolts and washers through the slotted hole at the bottom of the Tool Rest and reattach them to the grinding stone guard (4).
4. Position the Tool Rest no more than 1/8 in. away from the Grinding Stone (5).
5. Tighten the two mounting bolts securely, using the appropriate size metric combination wrench, to prevent the Tool Rest from moving during usage of the bench grinder.

**NOTE** As the grinding stones wear down, adjust the tool rest inward maintaining the 1/8 in. gap.

6. Repeat the assembly operation for the second Tool Rest.

**WARNING** To reduce the risk of injury, never connect plug to power source outlet until all assembly steps are completed.

**CAUTION** Prior to fitting the eye shields and spark deflectors, ensure the grinder is turned off and the power plug is removed from the socket.

**NOTE** Always check to ensure the eye shields are correctly fitted and the eye shield spark deflectors are correctly adjusted each time the grinder is used. Eye shields and spark deflectors must be fitted over each grinding wheel.

### INSTALLING THE SPARK DEFLECTORS

1. Remove the two Spark Deflectors (3) and the two smaller bolts and washers (6) from the parts bag.
2. Install the Spark Deflectors to the Wheel Guards (5) as shown in Figure 3. Adjust them to within 1/8 in. of the Grinding Wheel.

### INSTALLING THE EYE SHIELDS

1. Remove the bolt, washer (2) and Eye Shield Locking Knob (4) from the top of the Eye Shield (1).
2. Position the Eye Shield to the Eye Shield Bracket as shown in Figure 3.
3. Reinsert the bolt through the Eye Shield Bracket and Eye Shield, followed by the washer and Eye Shield Locking Knob.
4. Tighten to secure the Eye Shield to the Eye Shield Bracket.
5. Repeat (mirror) for the opposite side.

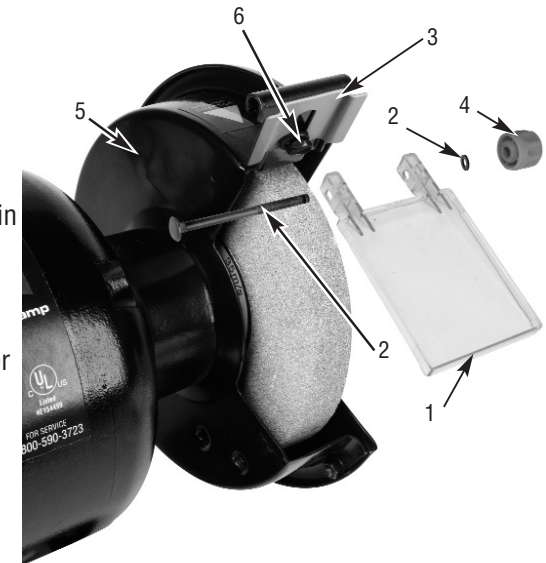

FIGURE 3. INSTALLING THE EYE SHIELD



## OPERATING THE BENCH GRINDER

### CAUTION

Ensure the “ON/OFF” switch is in the “OFF” position before plugging the power cord into the AC power source. Ensure there are no tools or work pieces in contact with the grinding wheels when the grinder is turned “ON.” Failure to observe these procedures could result in damage to the bench grinder, tools, work pieces, or serious personal injury to the operator or bystanders.

## OPERATING THE ON/OFF SWITCH

The bench grinder “ON/OFF” switch is located on the front of the grinder base. To turn the grinder “ON,” move the rocker-style switch to the **right** to the “ON” position. To turn the grinder “OFF,” move the rocker-style switch to the **left** to the “OFF” position.

## GRINDER OPERATIONS

### CAUTION

When sharpening tools on a grinder, avoid letting the tool stay in one place until it becomes “RED HOT.” You will notice area will change color, possibly to a bluish tint, when the tool cools. This change in color and the exposure to high heat can alter the tempering of the metal making it more brittle and subject to frequent surface damage.

- Before starting any grinding operation, check the grinding wheels are properly dressed and have no rounded edges, gouges, or grooves. Refer to the section, “**Maintenance and Cleaning**” (pages 16-19) for procedures on dressing the grinding wheels.
- Ensure the tool rests are securely tightened and the eye shields are in place and properly tightened.
- Allow the grinder to run for at least **one minute** to warm up the grinding wheels. **NEVER place a work piece against a “COLD” grinding wheel.**
- The bench grinder is equipped with two aluminum oxide grinding wheels - one 36 grit (coarse) and one 60 grit (medium).
- Place the work piece on the tool rest and apply even pressure as contact is made with the abrasive stones.
- If the grinder is being used to sharpen heavy tools such as axes or lawnmower blades, start by using the coarse grinding wheel. This wheel removes a greater amount of surface. Then repeat the procedure using the medium wheel to give the

tools a finished sharpening. **NOTE: The finished edges on heavy tools such as axes or lawnmower blades need not be ground to a fine edge like that of a pocket knife or scissor. The edge needs to be free of nicks and uneven edges for maximum performance. A fine edge will only become damaged easier requiring more frequent sharpening.**

- When sharpening tools, start on one end of the tool and slide its surface across the grinding stone in a firm even speed and pressure. Reverse the direction for the other side.

### ⚠ WARNING

**DO NOT attempt to “grind” work pieces made of WOOD or MAGNESIUM. Using wood with a bench grinder could easily start a fire or cause severe irreversible damage to the work piece. Grinding work pieces made of magnesium or magnesium alloys can ignite causing sudden very intense fires. Magnesium fires cannot be easily extinguished. ABSOLUTELY DO NOT THROW WATER ON A MAGNESIUM FIRE. USE ONLY A FIRE EXTINGUISHER RATED FOR SUCH FIRES OR CALL FOR ASSISTANCE (9-1-1). When water is introduced to a magnesium fire, the sudden temperature change could cause the metal to explode sending very hot pieces throughout the work area possibly igniting other fires.**

- Use optional accessories such as wire wheels and buffing wheels to create finishing touches to your work piece.
- **WIRE WHEELS** should never be used on work pieces that are polished or have a textured surface. The wheel will deface these surfaces. Like grinding stones, work pieces can be held too long against the wire wheels resulting in high temperatures and possible damage to the work piece.

Consult with Alltrade Customer Service at **1-800-423-3598 (toll free)** for assistance in choosing the proper grinding wheels and accessories for your grinder.

## MAINTENANCE AND CLEANING

During normal use, the abrasive grinding wheels may become cracked, grooved, develop rounded corners on the edges, chipped, loaded with foreign material or worn from the original shape and will need to be replaced. **Grinding wheels that are chipped or cracked should be replaced IMMEDIATELY.**

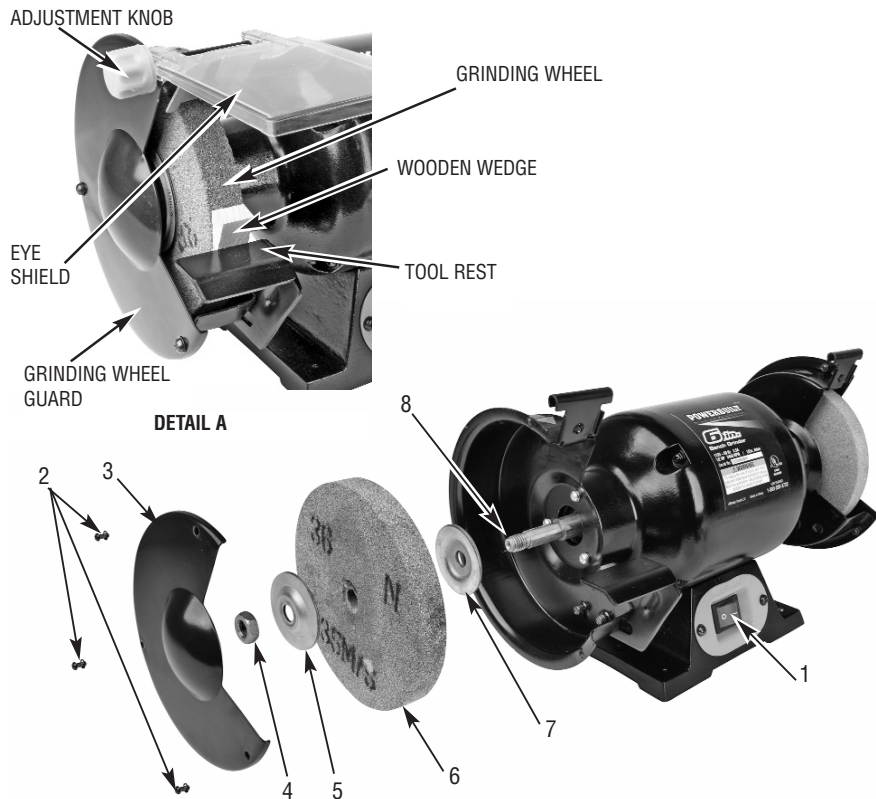

FIGURE 4. REPLACING GRINDING WHEEL

## REPLACING GRINDING WHEELS

When replacing grinding wheels, make sure the replacement wheel has a speed rating at or above the speed of the grinder. The speed rating is listed on the nameplate of the grinder. Replacement grinding wheels should have a 1/2 in. arbor hole and a maximum width of 3/4 in. See Figure 4.

1. Ensure the **POWER SWITCH** (1) is set to the “OFF” position and the electrical power cord is removed from the power source before changing grinding wheels.
2. Loosen the Adjustment Knob and lift the Eye Shields to the UP position. The Eye Shield and Adjustment Knob are shown in Detail A, above.
3. Remove the three screws (2) and remove the outer cover of the Grinding Stone Guard (3).
4. Remove the rear bolt attaching the Tool Rest to the Grinding Wheel Guard.

5. Loosen the front bolt on the Tool Rest. Move the Tool Rest forward as far from the Grinding Shield Guard as possible and re-tighten.
6. Wedge a small piece of wood between the Tool Rest and the Grinding Stone to prevent it from turning.
7. Using a wrench, loosen and remove the Arbor Nut (4) from the Motor Spindle (8).

**CAUTION** The Motor Spindle has left-hand threads on the left side and right-hand threads on the right side. Left-hand threads **LOOSEN** by turning them clockwise where as right hand threads loosen by turning them counter-clockwise. This prevents the spindle nuts from becoming loose during grinder operations.

8. Remove the Outer Arbor Flange (5) and the old grinding wheel.
9. Slide the **NEW** Grinding Stone onto the Motor Spindle and ensure it seats with the Inner Arbor Flange (7). Install the Outer Arbor Flange (5) and the Arbor Nut (4).
10. Wedge a small piece of wood between the Tool Rest and the Grinding Stone to prevent it from turning. The Tool Rest is pictured in Detail A on page 17.
11. Using a wrench, tighten the Arbor Nut (4) to 8 Lbs-Ft.
12. Place the outer cover of the Grinding Stone Guard and secure it with the three screws (2) that were removed in Step 3, above.
13. Remove the wedge and reposition the Tool Rest no more than 1/8 in. away from the Grinding Stone and fasten all hardware.

## DRESSING THE GRINDING WHEELS

After using the grinding for a period of time, the wheel surface could become grooved and the edges rounded. Re-surfacing the grinding wheel is called “dressing the wheel.” Use a suitable silicone carbide, stick-type dresser or the wheel dresser provided with the grinder. An uneven grinding wheel can cause poor results upon grinding items that use the entire surface of the wheel. Follow the steps below to dress the grinding wheel.

1. Turn on the grinder.
2. Set the dresser on the tool rest and move it forward against the moving wheel until it touches the high point.
3. Dress the grinding wheel by moving the dresser back and forth.
4. Repeat this operation until the surface of the grinding wheel is clean and free of grooves or gouges and the wheel edges are square to the wheel surface.
5. Repeat this operation on both grinding stones.

## CLEANING THE BENCH GRINDER

- The bench grinder should only be cleaned after the power cord is removed from the power source and the Power Switch is turned to “OFF.” Clean any dust buildup from around moving parts or near electrical connections. This dust can possibly contain metallic shavings that could cause electricity to be conducted from the grinder parts to a grounded object. Use a clean rag, brush, or compressed air source to remove excessive dust buildup.
- **NEVER** use flammable materials to clean the grinder.
- **NO LUBRICATION** is required. The grinder motor uses sealed lubrication bearings installed at the factory.

## FLEXIBLE WORK LIGHT (691589)

**⚠ WARNING** To reduce the risk of fire, **NEVER** use a bulb with a wattage higher than 40 watts. Use only type “A” bulb, 40 watt (max), 120V.

The Work Light features a flexible arm with a light attached.

1. Turn the Power Switch to the “OFF” position and unplug the power cord from the electrical power source.
2. Make sure the Bench Grinder has a chance to cool down to avoid personal injury when replacing light bulb (bulb not included).
3. To remove the bulb, turn counterclockwise. To install new bulb, turn clockwise.

## ACCESSORIES

**⚠ WARNING** Only use accessories that are designed to fit your particular grinder. These accessories should be specifically labeled to match the speed and arbor size of the grinder. Failure to use the proper accessories could result in property damage, damage to the grinder, and serious personal injury to the operator.

Optional accessories for the bench grinder can include wire-brush wheels that can be used for cleaning and layered cloth wheels that can be used for polishing and buffing. Contact ALLTRADE Customer Service at **1-800-423-3598** (toll free) to find out what accessories are available for the bench grinder.

**Always attach grounded (3-prong) extension cords to grounded (3-hole) outlets. If the grinder must be used outside, use an extension cord labeled “W-A” or “W.”** These extension cords are rated for outdoor use and reduce the chances of electrical shock.

**If you must use an extension cord, be sure that the gauge is large enough to carry the amount of current necessary for your power tool.** If not, your tool may experience a loss of power, excessive voltage drop or overheating. The smaller the gauge number, the heavier the cord (see table below).

## RECOMMENDED SIZES OF EXTENSION CORDS 120 VOLT AC 60 HZ TOOLS

TOOL CURRENT RATING	CONDUCTOR SIZE IN A.W.G				
	AMPERE	10FT.	25FT.	50FT.	100FT.
3-6	16	16	16	16	16
6-8	16	16	16	16	16
8-10	16	16	16	16	14
10-12	16	16	14	14	14
12-16	14	12	12	12	-
16-20	12	12	12	12	-

## SPECIFICATIONS

### SPECIFICATIONS

Voltage	120V  60 Hz
Rated Current	3.5 A
No-Load Speed	3450 RPM
Grinding Wheel Size	6 in. x 3/4 in. x 1/2 in.
Light Bulb (691589)	Type “A”, 40 watt(max), 120V

## OTHER CONSUMER DO-IT-YOURSELF (DIY) TOOLS

Alltrade offers a full range of Alltrade tools that make DIY jobs easy. If you would like further information on the following products, please contact Alltrade Customer Service Department at 1-800-423-3598.

Cordless Drills/Screwdrivers	Reciprocating Saws
Impact Wrenches	Routers
Sanders	Rotary Tools
Jigsaws	Corded and Cordless Multi-Purpose Tools
Circular Saws	Wide Range of Accessories and more
Angle Grinders	

## 1 YEAR LIMITED HOME USE WARRANTY

### Express and Exclusive Limited Home Use Warranty to Original Retail Buyer

Alltrade Tools LLC (hereinafter "Alltrade") expressly warrants to the original retail purchaser of the accompanying ALLTRADE portable power tool and no one else all parts of the product (except those parts referred to below which are specifically excluded from such warranty (see Exclusions)) to be free from defects in materials and workmanship for a period of one year from original date of purchase.

**SPECIAL WARRANTY NOTE TO CONTRACTORS AND COMMERCIAL USERS:** This Alltrade portable power tool is offered as a home use tool and carries a **HOME USE WARRANTY**. This tool is made for home use in the execution of projects and repairs in and around the home. Use of the tool for **COMMERCIAL PURPOSES OR ON A JOBSITE** is not covered under this warranty.

The date of purchase shall be the date of shipment to the original purchaser, or the date the original purchaser took possession, custody or control of the product, whichever occurred first. This warranty shall be null and void if the product or any component thereof is modified, altered or used for any commercial purpose or on a jobsite. This warranty does not apply to any other product and/or component thereof manufactured or distributed by Alltrade, and does not apply to products and/or components thereof designed, manufactured and/or assembled by others, for which Alltrade makes no warranties whatsoever. **THERE ARE NO WARRANTIES WHICH EXTEND BEYOND THE DESCRIPTION ON THE FACE HEREOF.**

### Warranty Performance

By purchasing the product, purchaser expressly acknowledges and agrees that their sole and exclusive remedy under this warranty shall be strictly limited to the repair or replacement of any covered nonconforming items or parts thereof provided that any such nonconforming item and/or part is promptly returned to Alltrade's facility postage pre-paid and insured (address: ALLTRADE Warranty Claims & Repair, 1431 Via Plata, Long Beach, CA 90810, Attn: Customer Service #1-800-423-3598) within the applicable warranty period, with a written request by purchaser that Alltrade repair and/or replace the nonconforming item and/or part. We recommend that you keep the original product packaging in the event you need to ship the unit. We suggest the package be insured against loss or in transit damage. When sending your product include your name, address, phone number, dated proof of purchase (or copy), and a statement about the nature of problem. Warranty coverage is conditioned upon purchaser furnishing Alltrade with adequate written proof that they are the original purchaser and of the original purchase date. Parts returned, freight prepaid and insured, to Alltrade's facility (see above address) will be inspected and, at Alltrade's option, repaired and/or replaced free of charge if found to be defective and subject to warranty. Alltrade retains the sole discretion to determine whether any item or part is nonconforming and, if so, whether the

item and/or part will be repaired and/or replaced. If the unit is repaired, new or reconditioned replacement parts may be used. If Alltrade chooses to replace the product, it may replace it with a new or reconditioned one of the same or comparable design. The repaired or replaced unit will be warranted under the terms of the remainder of the warranty period. Typically, a defective product that is returned within the first 30 days after the purchase date will be replaced; for items returned after the first 30 days and within the warranty period, covered defective parts not subject to normal wear and tear or other exclusions will be repaired or replaced, at Alltrade's option. During the warranty period, Alltrade will be responsible for the return shipping charges. Alltrade's repair and/or replacement of any non-conforming item and/or part thereof shall constitute fulfillment of all obligations to the purchaser. Alltrade shall not be responsible or liable for any expense, including freight charges, or repairs made outside Alltrade's facility, unless expressly agreed to by Alltrade in writing. Under no circumstances shall Alltrade bear any responsibility for loss of the unit, loss of time or rental, inconvenience, commercial loss or consequential damages.

### Exclusions

This warranty does not cover parts damaged due to normal wear, abnormal conditions, misapplication, misuse, abuse, accidents, operation at other than recommended pressures or temperatures, improper storage or freight damage. Parts damaged or worn by operation in dusty environments are not warranted. Failure to follow recommended operating and maintenance procedures also voids warranty.

This limited warranty does not apply to accessory items such as drill bits, screwdriving bits, circular saw blades, jigsaw blades, grinding wheels, sanding sheets and other related items.

**DAMAGE TO THE PRODUCT RESULTING FROM TAMPERING, ACCIDENT, ABUSE, NEGLIGENCE, FAILURE TO FOLLOW INSTRUCTIONS, UNAUTHORIZED REPAIRS OR ALTERATIONS, DAMAGE WHILE IN TRANSIT TO OUR SERVICE FACILITY, USE OF UNAPPROVED OR IMPROPER ATTACHMENTS OR ACCESSORIES, COMMERCIAL AND RENTAL APPLICATIONS OR OTHER CAUSES UNRELATED TO PROBLEMS WITH MATERIAL OR WORKMANSHIP ARE NOT COVERED BY THIS WARRANTY.**

Alltrade will not be liable for the following: labor charges, loss or damage resulting from improper operation, maintenance or repairs made by other persons; pre-delivery services such as assembly, oil or lubricants, and adjustment; maintenance services that are normally required to maintain the product.

The use of other than genuine Alltrade Repair Parts will void warranty.

**Warranty Disclaimers**

EXCLUSION AND DISCLAIMER OF ALL OTHER EXPRESS WARRANTIES, GUARANTIES AND/OR REPRESENTATIONS. EXCEPT FOR THE LIMITED WARRANTY PROVIDED ABOVE, ALL OTHER EXPRESS WARRANTIES, GUARANTIES AND/OR REPRESENTATIONS BY ALLTRADE AND/OR ITS REPRESENTATIVE(S) REGARDING THE DESIGN, MANUFACTURE, PURCHASE, USE AND/OR OPERATION OF THE PRODUCT OR ANY COMPONENT THEREOF SOLD HEREUNDER, REGARDLESS OF WHETHER ANY SUCH WARRANTY, GUARANTY AND/OR REPRESENTATION, WRITTEN OR ORAL, ARISES BY OPERATION OF LAW AND/OR EQUITY AND/OR BY ANY ACT OR OMISSION OF ALLTRADE AND/OR ITS REPRESENTATIVE(S), OR THE BUYER, ARE HEREBY EXPRESSLY EXCLUDED AND DISCLAIMED BY ALLTRADE AND/OR ITS REPRESENTATIVES. PURCHASER KNOWINGLY AND WILLINGLY WAIVES ANY AND ALL SUCH WARRANTIES AND RIGHTS, CLAIMS AND/OR CAUSES OF ACTION ARISING THEREFROM OR BASED THEREON. PURCHASER'S SOLE AND EXCLUSIVE REMEDY IS AS STATED ABOVE.

EXCLUSION AND DISCLAIMER OF ALL IMPLIED WARRANTIES, INCLUDING THE IMPLIED WARRANTIES OF MERCHANTABILITY AND FITNESS FOR A PARTICULAR PURPOSE. NO WARRANTY, ORAL OR WRITTEN, OTHER THAN THE ABOVE WARRANTY IS MADE WITH REGARD TO THIS PRODUCT. ALL EXPRESS AND/OR IMPLIED WARRANTIES, GUARANTIES AND/OR REPRESENTATIONS BY ALLTRADE AND/OR ITS REPRESENTATIVE(S) REGARDING THE DESIGN, MANUFACTURE, PURCHASE, USE AND/OR OPERATION OF THE PRODUCT OR ANY COMPONENT THEREOF SOLD HEREUNDER, REGARDLESS OF WHETHER ANY SUCH WARRANTY, GUARANTY AND/OR REPRESENTATION, WRITTEN OR ORAL, ARISES BY OPERATION OF LAW AND/OR EQUITY AND/OR BY ANY ACT OR OMISSION OF ALLTRADE AND/OR ITS REPRESENTATIVE(S), OR THE PURCHASER, INCLUDING BUT NOT LIMITED TO THE IMPLIED WARRANTY OF MERCHANTABILITY AND THE WARRANTY OF FITNESS FOR A PARTICULAR PURPOSE, ARE HEREBY EXPRESSLY EXCLUDED AND DISCLAIMED BY ALLTRADE AND/OR ITS REPRESENTATIVES. PURCHASER KNOWINGLY AND WILLINGLY WAIVES ANY AND ALL SUCH WARRANTIES AND RIGHTS, CLAIMS AND/OR CAUSES OF ACTION ARISING THEREFROM OR BASED THEREON. PURCHASER'S SOLE AND EXCLUSIVE REMEDY IS AS STATED ABOVE.

**Limitation Of Liability**

IN NO EVENT SHALL ALLTRADE AND/OR ITS REPRESENTATIVE(S) BE LIABLE FOR INDIRECT, INCIDENTAL, SPECIAL AND/OR CONSEQUENTIAL DAMAGES OF ANY KIND ARISING OUT OF OR RELATED TO, DIRECTLY OR INDIRECTLY, ANY BREACH OF ANY PROVISION OF ANY AGREEMENT BETWEEN ALLTRADE AND/OR ITS REPRESENTATIVE(S) AND PURCHASER, ANY WARRANTY HEREUNDER, AND/OR THE EXISTENCE, DESIGN, MANUFACTURE, PURCHASE, USE AND/OR OPERATION OF ANY ITEM(S) SOLD HEREUNDER EVEN IF ALLTRADE AND/OR ITS

REPRESENTATIVE(S) HAS BEEN ADVISED OF THE POSSIBILITY OF ANY SUCH DAMAGES. IN NO EVENT, WHETHER AS A RESULT OF A BREACH OF CONTRACT, WARRANTY, TORT (INCLUDING NEGLIGENCE) OR OTHERWISE, SHALL ALLTRADE'S AND/OR ITS REPRESENTATIVE(S)' LIABILITY EXCEED THE PRICE OF THE PRODUCT. ANY AND ALL LIABILITY CONNECTED WITH THE USE OF THIS PRODUCT SHALL TERMINATE UPON THE EXPIRATION OF THE WARRANTY PERIODS SPECIFIED ABOVE.

**Limitations on Warranty Disclaimers**

Some states do not allow limitations on how long an implied warranty lasts and some states do not allow the exclusion or limitation of the incidental or consequential damages, so part or all of the above limitations or exclusions may not apply to you. This warranty gives you specific legal rights, and you may also have other rights which vary from state to state.

If your product is not covered by this warranty, please call our Customer Service Department toll free at 1-800-423-3598 for general repair information and charges.