

7.4 Volumes of Cones

Essential Question How can you remember the formulas for surface area and volume?

You discovered that the volume of a pyramid is one-third the volume of a prism that has the same base and same height. You can use a similar activity to discover that the volume of a cone is one-third the volume of a cylinder that has the same base and height.

$$\text{Volume of a Cone} = \frac{1}{3}(\text{Area of Base}) \times (\text{Height})$$

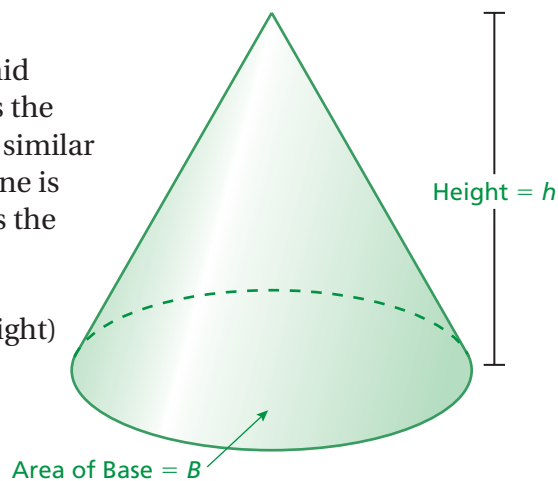

1 ACTIVITY: Summarizing Volume Formulas

Work with a partner. You can remember the volume formulas for all of the solids shown with just two concepts.

Volumes of Prisms and Cylinders

$$\text{Volume} = (\text{Area of Base}) \times (\text{Height})$$

Volumes of Pyramids and Cones

$$\text{Volume} = \frac{1}{3} (\text{Volume of Prism or Cylinder with same base and height})$$

Make a list of all the formulas you need to remember to find the area of a base. Talk about strategies for remembering these formulas.

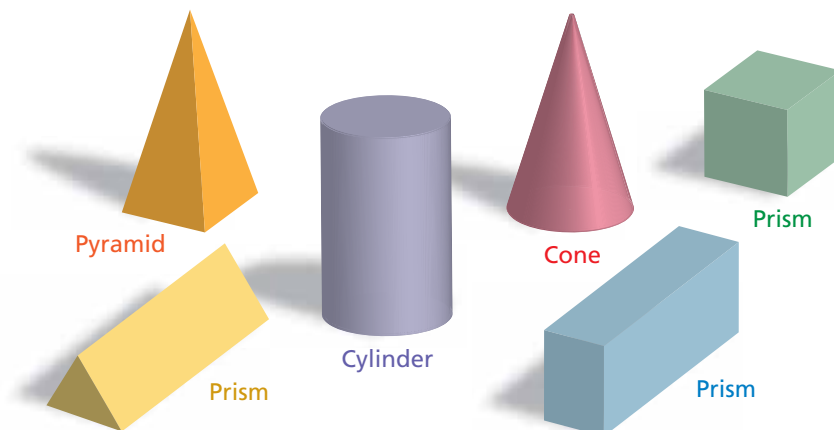

2 ACTIVITY: Volumes of Oblique Solids

Work with a partner. Think of a stack of paper. If you adjust the stack so that the sides are oblique (slanted), do you change the volume of the stack? If the volume of the stack does not change, then the formulas for volumes of right solids also apply to oblique solids.

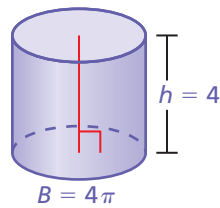

Right cylinder

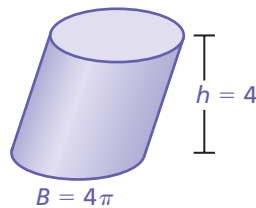

Oblique cylinder

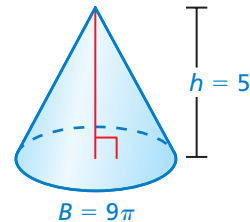

Right cone

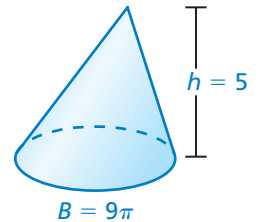

Oblique cone

3 ACTIVITY: Summarizing Surface Area Formulas

Work with a partner. Make a list of the formulas for surface area that you studied in Chapter 6. Organize these formulas in a way similar to what you did in Activity 1.

Surface Area of a Right Prism =

Surface Area of a Right Pyramid =

Surface Area of a Right Cylinder =

Surface Area of a Right Cone =

What Is Your Answer?

4. **IN YOUR OWN WORDS** How can you remember the formulas for surface area and volume? Write all of the surface area and volume formulas on a summary sheet. Make the list short so that you do not have to memorize many formulas.

Practice

Use what you learned about the volumes of cones to complete Exercises 4–6 on page 320.

Key Idea
Volume of a Cone

Words The volume V of a cone is one-third the product of the area of the base and the height of the cone.

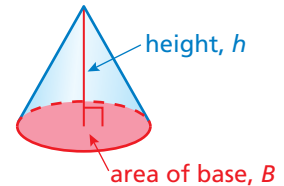

Algebra $V = \frac{1}{3}Bh$

Area of base

Height of cone

EXAMPLE 1 Finding the Volume of a Cone**Study Tip**

Because $B = \pi r^2$, you can use $V = \frac{1}{3}\pi r^2 h$ to find the volume of a cone.

Find the volume of the cone. Round your answer to the nearest tenth.

The diameter is 4 meters. So, the radius is 2 meters.

$$V = \frac{1}{3}Bh \quad \text{Write formula.}$$

$$= \frac{1}{3}\pi(2)^2(6) \quad \text{Substitute.}$$

$$= 8\pi \approx 25.1 \quad \text{Simplify.}$$

••• The volume is about 25.1 cubic meters.

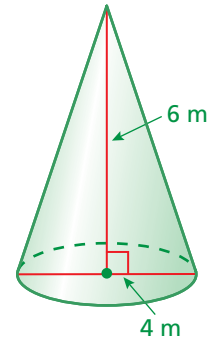
**EXAMPLE 2** Finding the Height of a Cone

Find the height of the cone. Round your answer to the nearest tenth.

$$V = \frac{1}{3}Bh \quad \text{Write formula.}$$

$$956 = \frac{1}{3}\pi(9)^2(h) \quad \text{Substitute.}$$

$$956 = 27\pi h \quad \text{Simplify.}$$

$$11.3 \approx h \quad \text{Divide each side by } 27\pi.$$

••• The height is about 11.3 feet.

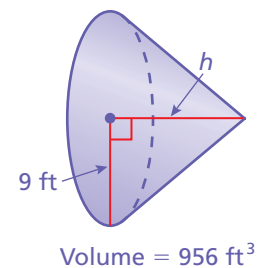

Volume = 956 ft^3

On Your Own

Find the volume V or height h of the cone. Round your answer to the nearest tenth.

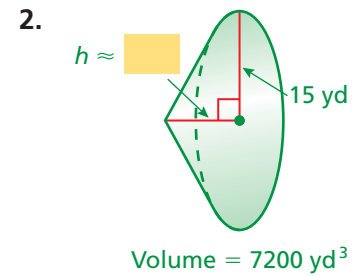
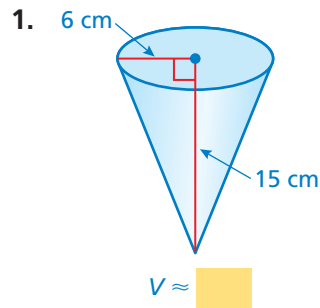

EXAMPLE 3 Real-Life Application

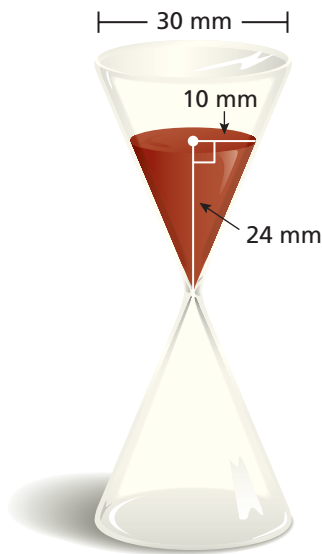

You must answer a trivia question before the sand in the timer falls to the bottom. The sand falls at a rate of 50 cubic millimeters per second. How much time do you have to answer the question?

Use the formula for the volume of a cone to find the volume of the sand in the timer.

$$V = \frac{1}{3}Bh \quad \text{Write formula.}$$

$$= \frac{1}{3}\pi(10)^2(24) \quad \text{Substitute.}$$

$$= 800\pi \approx 2512 \quad \text{Simplify.}$$

The volume of the sand is about 2512 cubic millimeters. To find the amount of time you have to answer the question, multiply the volume by the rate at which the sand falls.

$$2512 \text{ mm}^3 \times \frac{1 \text{ sec}}{50 \text{ mm}^3} = 50.24 \text{ sec}$$

∴ You have about 50 seconds to answer the question.

On Your Own

- WHAT IF?** In Example 3, the sand falls at a rate of 60 cubic millimeters per second. How much time do you have to answer the question?
- WHAT IF?** In Example 3, the height of the sand in the timer is 12 millimeters and the radius is 5 millimeters. How much time do you have to answer the question?

Vocabulary and Concept Check

- VOCABULARY** Describe the height of a cone.
- WRITING** Compare and contrast the formulas for the volume of a pyramid and the volume of a cone.
- REASONING** You know the volume of a cylinder. How can you find the volume of a cone with the same base and height?

Practice and Problem Solving

Find the volume of the cone. Round your answer to the nearest tenth.

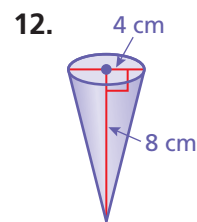
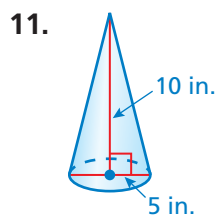
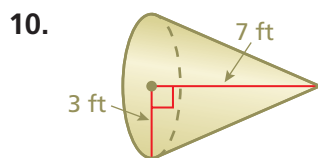
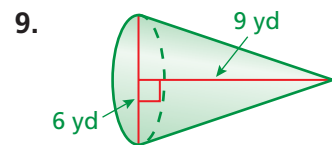
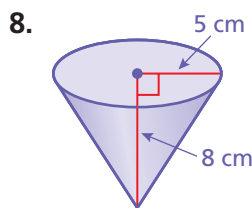
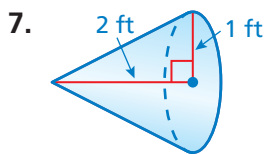
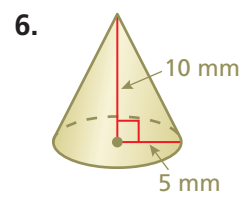
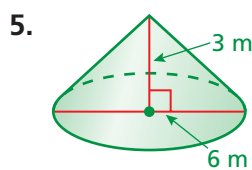
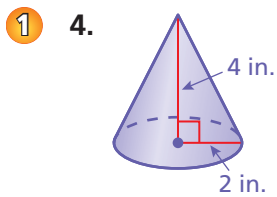

13. **ERROR ANALYSIS** Describe and correct the error in finding the volume of the cone.

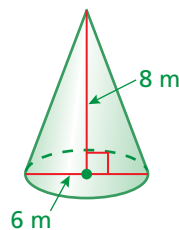

X

$$V = \frac{1}{3}Bh$$

$$= \frac{1}{3}(\pi)(6)^2(8)$$

$$= 96\pi \text{ m}^3$$

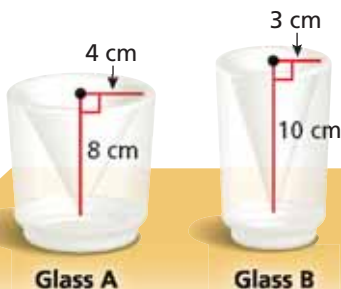

14. **GLASS** The inside of each glass is shaped like a cone. Which glass can hold more liquid? How much more?

Find the height of the cone. Round your answer to the nearest tenth.

2 15. Volume = $\frac{1}{18}\pi \text{ ft}^3$

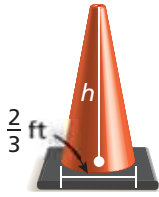

16. Volume = 225 cm^3

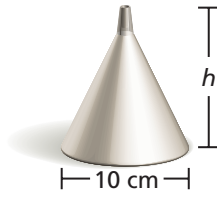

17. Volume = 3.6 in.^3

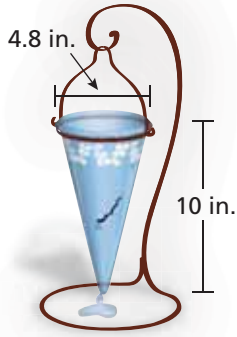
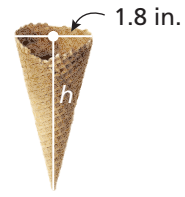

18. **REASONING** The volume of a cone is 20π cubic meters. What is the volume of a cylinder having the same base and same height?

19. **VASE** Water leaks from a crack in a vase at a rate of 0.5 cubic inch per minute. How long does it take for 20% of the water to leak from a full vase?

20. **LEMONADE STAND** You have 10 gallons of lemonade to sell. (1 gal $\approx 3785 \text{ cm}^3$)

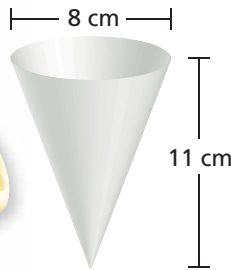

- Each customer uses one paper cup. How many paper cups will you need?
- The cups are sold in packages of 50. How many packages should you buy?
- How many cups will be left over if you sell 80% of the lemonade?

21. **REASONING** The cylinder and the cone have the same volume. What is the height of the cone?

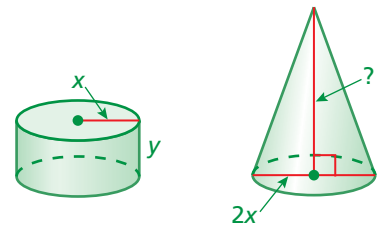

22. **Critical Thinking** Cone A has the same height but twice the radius of Cone B. What is the ratio of the volume of Cone A to the volume of Cone B?



Fair Game Review What you learned in previous grades & lessons

Find the volume of the solid.

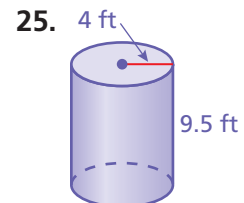
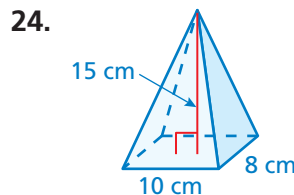
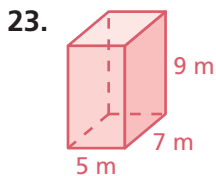

26. **MULTIPLE CHOICE** Which scale has a scale factor of 3 : 1?

- (A) 1 in. : 2 ft (B) 3 cm : 1 mm (C) 5 ft : 15 yd (D) 0.5 ft : 2 in.