



MOTOROLA

ASTRO[®] Spectra[®] and Digital Spectra[®]
FM Two-Way Mobile Radios
Installation Manual

Foreword

The information contained in this manual relates to all Spectra® and ASTRO® Digital Spectra® mobile radios unless otherwise specified. This manual provides information for installation of a Spectra or ASTRO Digital Spectra mobile radio.

Safety Information

Before operating a Spectra or ASTRO Digital Spectra mobile radio, please read the Motorola “Product Safety and RF Energy Exposure Booklet for Mobile Two-Way Radios Installed in Vehicles or as Fixed Site Control Stations.”

Manual Revisions

Changes which occur after this manual is printed are described in “FMRs.” These FMRs provide complete information on changes including pertinent parts listing data.

Computer Software Copyrights

The Motorola products described in this manual may include copyrighted Motorola computer programs stored in semiconductor memories or other media. Laws in the United States and other countries preserve for Motorola certain exclusive rights for copyrighted computer programs, including, but not limited to, the exclusive right to copy or reproduce in any form the copyrighted computer program. Accordingly, any copyrighted Motorola computer programs contained in the Motorola products described in this manual may not be copied, reproduced, modified, reverse-engineered, or distributed in any manner without the express written permission of Motorola. Furthermore, the purchase of Motorola products shall not be deemed to grant either directly or by implication, estoppel, or otherwise, any license under the copyrights, patents or patent applications of Motorola, except for the normal non-exclusive license to use that arises by operation of law in the sale of a product.

Installation Requirements for Compliance with Radio Frequency (RF) Energy Exposure Safety Standards

ATTENTION!

This radio is intended for use in occupational/controlled conditions, where users have full knowledge of their exposure and can exercise control over their exposure to meet FCC limits. This radio device is NOT authorized for general population, consumer, or any other use.

To ensure compliance to RF Energy Safety Standards:

- Install only Motorola approved antennas and accessories.
- Be sure that antenna installation is per Antenna Installation on page 3-8 of this manual.
- Be sure that Product Safety and RF Safety Booklet enclosed with this radio is available to the end user upon completion of the installation of this radio.

Before using this product, the operator must be familiar with the RF energy awareness information and operating instructions in the Product Safety and RF Exposure booklet enclosed with each radio (Motorola publication part number 6881095C99_) to ensure compliance with Radio Frequency (RF) energy exposure limits.



WARNING

For radios installed in vehicles fuelled by liquefied petroleum gas, refer to the (U.S.) National Fire Protection Association standard, NFPA58, for storage, handling, and/or container information.

This radio has a transmitter Time-out Timer that disables the transmitter during a transmission after a predefined time period, which by default is set to 60 seconds.



Caution

It is recommended NOT to change the default 60 seconds time period for the Time-out Timer as the radio is intended for intermittent duty cycle operation.

For a list of Motorola-approved antennas and other accessories, visit the following web site, which lists approved accessories for your radio model:

<http://www.motorola.com/governmentandenterprise>

Notes

Table of Contents

1 - Description	1
Introduction	1
Radio Model, Control Head, and Version Identification	1
Radio Dimensions	2
Base/Control Stations	2
2 - Installation	4
Planning the Installation	4
Speaker Installation	4
Microphone Hang-up Clip Installation	8
Handheld Hang-up Box Installation (A3 Model Control Head)	8
Low-/Mid-Power Radio Power Cable Installation	8
High-Power Radio Power Cable Installation	8
Remote Radio Control Cable Installation	9
Dash Mount Radio Installation	10
Locking Kit Installation (Optional)	10
Remote Mount Low-/Mid-Power Radio Installation	10
Remote Mount High-Power Radio Installation	11
Remote A4, A5, A7, and A9 Model Control Head Installation	12
Remote A3 Model Control Head Installation	13
Transmit/Receive Control Cable Installation (A4, A5, A7, and A9 Remote Control Heads)	14
Transmitter Control Power Lead (Orange)	16
Receiver Control Power Lead (Green)	17
Ignition Cable (for Remote A3 Control Heads and Dash Mount Radios)	17
Alternator Whine Suppressor Installation	17
Antenna Installation	17
Selecting an Antenna Site/Location on a Metal Body Vehicle	17
Antenna Installation Procedure	18
Antenna Connection	19
Phone Button Key Installation	19
Options and Accessories Installation for A4, A5, A7, and A9 Model Control Heads	20
VIP Output Connections	20
VIP Input Connections	20
Emergency Pushbutton, Footswitch, Horn Relay, and Light Relay Installation	21
Emergency Pushbutton or Footswitch Installation	21
Horn (External Alarm) Relay Installation	21
Lights (External Alarm) Relay Installation	21
Options and Accessories Installation	21
MDC Emergency Pushbutton or Footswitch Installation	22
Horn and Lights (External Alarms) Relays	22
Connecting Cables	24
Replacement Parts Ordering	inside rear cover

A, Motorola, ASTRO, and Spectra are trademarks of Motorola Inc.

List of Figures

Figure 1	Example of a Base/Control Station Configuration	3
Figure 2	High-Power Radio Installation (Remote) Using A4, A5, A7 or A9 Control Heads	5
Figure 3	High-Power Radio Installation (Remote) Using A3 Control Heads	5
Figure 4	Low-/Mid-Power Radio Installation (Dash Mount) Using A4, A5, or A7 Control Heads.	6
Figure 5	Low-/Mid-Power Radio Installation (Remote) Using A4, A5, A7 or A9 Control Heads	6
Figure 6	Low-/Mid-Power Radio Installation (Dash Mount) Using A3 Control Heads.	7
Figure 7	Low-/Mid-Power Radio Installation (Remote) Using A3 Control Heads	7
Figure 8	Cabling Interconnect Diagram.	8
Figure 9	High-Power Main Fuse Assembly (40-Amp)	9
Figure 10	A4, A5, and A7 Control Head Installation Exploded View	13
Figure 11	A4, A5, and A7 Control Head Rear View	13
Figure 12	A9 Control Head Installation Exploded View	14
Figure 13	Alternator Whine Suppressor Isolation Detail.	15
Figure 14	Fuseholder Assembly and Parts List for Orange and Green Control Cables.	16
Figure 15	Antenna connections on the back of the radio.	18
Figure 16	Mini-UHF Connection.	19
Figure 17	Installing the Phone Button Key on A4, A5, and A7 Model Control Heads.	20
Figure 18	VIP Connector Detail	21
Figure 19	Emergency Switch Wiring Diagram	22
Figure 20	Horn/Light Wiring Diagram.	23

List of Tables

Table 1	Radio Functions Connections	15
---------	---------------------------------------	----

Related Publications

Spectra Detailed Service Manual	68P80102W61
ASTRO Spectra Motorcycle Radios Supplemental Installation Manual	68P80103W01
ASTRO Digital Spectra Hand-Held Control Head (Model W3) User's Guide	68P81073C25
Spectra VHF VCO Section Detailed Service Manual Supplement	68P81074C48
ASTRO Digital Spectra (Models W4, W5, W7, and W9) User's Guide	68P81074C80
ASTRO Digital Spectra Mobile Radios Basic Service Manual	68P81076C20
ASTRO Digital Spectra Mobile Radios Detailed Service Manual.	68P81076C25
Spectra High-Power Power Amplifier Detailed Service Manual Supplement	68P81077C25
Spectra Systems 9000 Control Unit Detailed Service Manual Supplement	68P81077C30
Spectra "E" Mobile Radios Detailed Service Manual	68P81077C40
Spectra A5 and A7 Control Head Instruction Manual.	68P81109C33
Spectra A4 Control Head Detailed Instruction Manual.	68P81109C34

Radio Dimensions

The Spectra and ASTRO Spectra Radios have the following dimensions (H x W x D):

15-watt – 2.0" x 7.1" x 7.5"

20- to 35-watt and 40-watt – 2.0" x 7.1" x 8.6"

Base/Control Stations

Model charts for the different versions are found in the basic service manual. "Versions" are identified by the model number "suffix." Although the charts are very similar, there are subtle but very important differences. Determine from the radio's identification label, which model control head and version is yours. Keep this information handy for future references. Determine the model and version of the radio as follows:



Caution

For outdoor antenna installations, proper site grounding and lightning protection are vitally important. Failure to provide proper lightning protection may result in permanent damage to the radio equipment. Refer to Motorola Quality Standards Fixed Network Equipment Installation Manual R56 (6881089E50), for complete information regarding lightning protection.

- The antenna should be mounted outside the building on the roof or a tower if at all possible and the antenna cable should be earth grounded.
- The radio chassis must be earth grounded and a lightning surge protector should be used in line with the radio connector and the outdoor antenna. The lightning surge protector should be earth grounded and located at the point where the antenna cable enters the building.
- The line voltage power supply must have a proper ground connection.
- As with all fixed site antenna installations, it is the responsibility of the licensee to manage the site in accordance with applicable regulatory requirements. Also, additional compliance actions such as site survey measurements, signage, and site access restrictions may be required in order to ensure that exposure limits are not exceeded.

Figure 1 shows a typical setup of a Base/Control Station configuration.

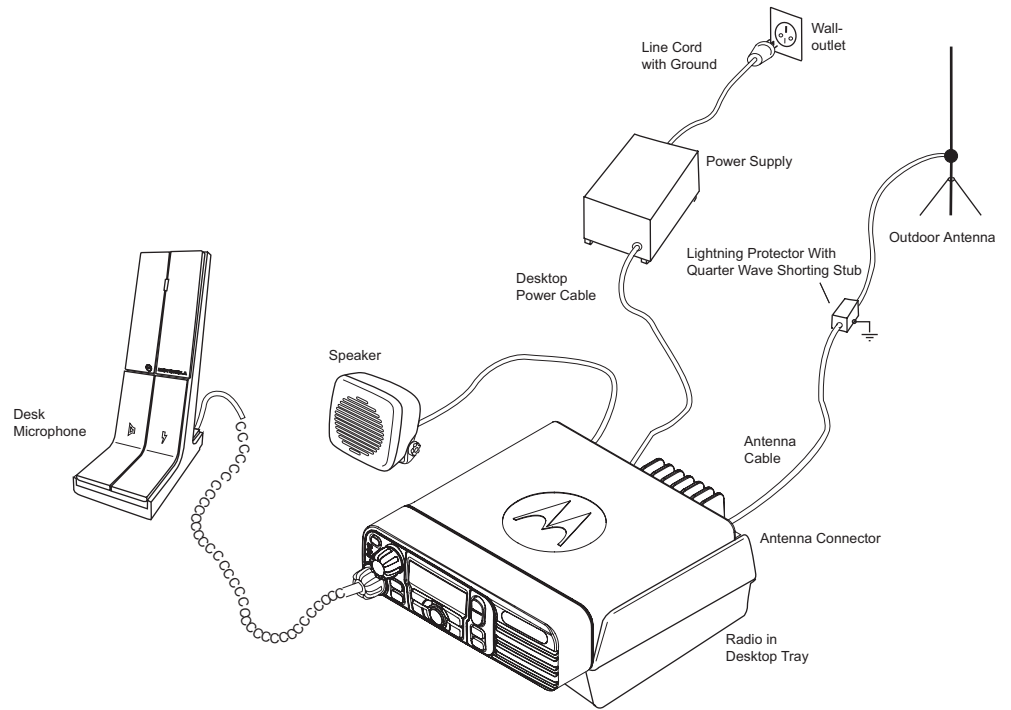

Figure 1 Example of a Base/Control Station Configuration

Installation

2

NOTE: In this manual, all information relating to a specific control-head model (A3, A4, A5, A7, or A9) will be applicable to a similar control head in the ASTRO Digital Spectra and Spectra radio families. Examples, A4 control head installation is also applicable to control heads B4, E4, and W4 control heads; A7 control head installation is also applicable to control heads B7, E7, and W7.

Planning the Installation

Figures 2 through 7 show all the possible configurations. The title under each figure identifies which power radio and which model control head is being shown and whether the radio can be remote or dash mounted (only low-/mid-power radios can be dash mounted). Identify which of the first six figures shows the configuration being installed and use the diagram when planning the installation.

The Spectra radio should operate only in negative ground electrical systems. Check the ground polarity of the vehicle before starting the radio installation making sure the polarity is correct. Accidentally reversing the polarity will not damage the radio, but will cause the cable fuses to blow.

Speaker Installation



Caution

DO NOT ground the radio's speaker leads. This system has a floating speaker output (dc voltage on both leads); damage to the audio circuit will result if either lead is grounded or if they are shorted together.

The speaker kit includes a trunnion bracket that allows the speaker to be mounted in a variety of ways. With the trunnion bracket, the speaker can mount permanently on the dashboard or in accessible firewall areas. The trunnion allows the speaker to tilt for best operation. Mount the speaker out of the way so that it will not be kicked or knocked around by the vehicle occupants. Mount the speaker as follows:

1. Use the speaker mounting bracket as a template to mark the mounting hole locations.
2. Use the self-drilling screws provided to fasten the trunnion.
3. Attach the speaker and fasten to the trunnion with two wing screws.
4. Route the speaker wires under the carpet or floor covering, or behind the kick panels. Be sure the wires are out of the way and will not be snagged and broken by the occupants of the vehicle.

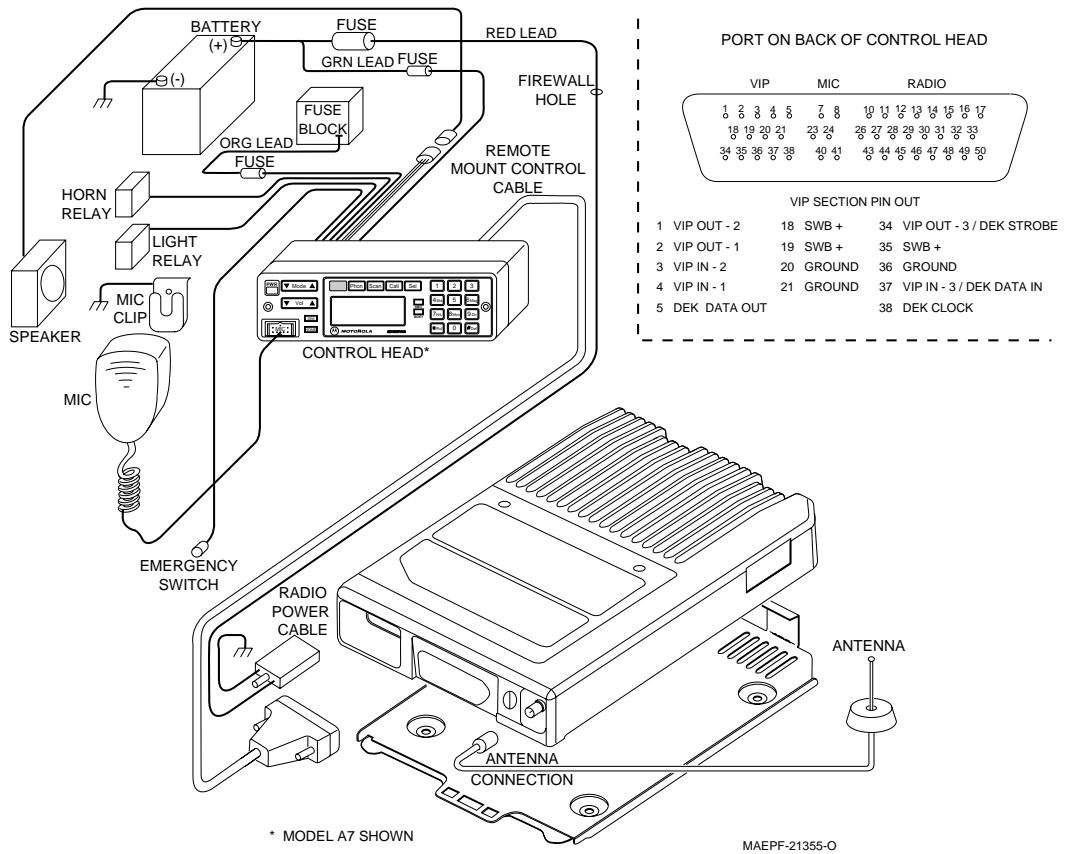

Figure 2 High-Power Radio Installation (Remote) Using A4, A5, A7 or A9 Control Heads

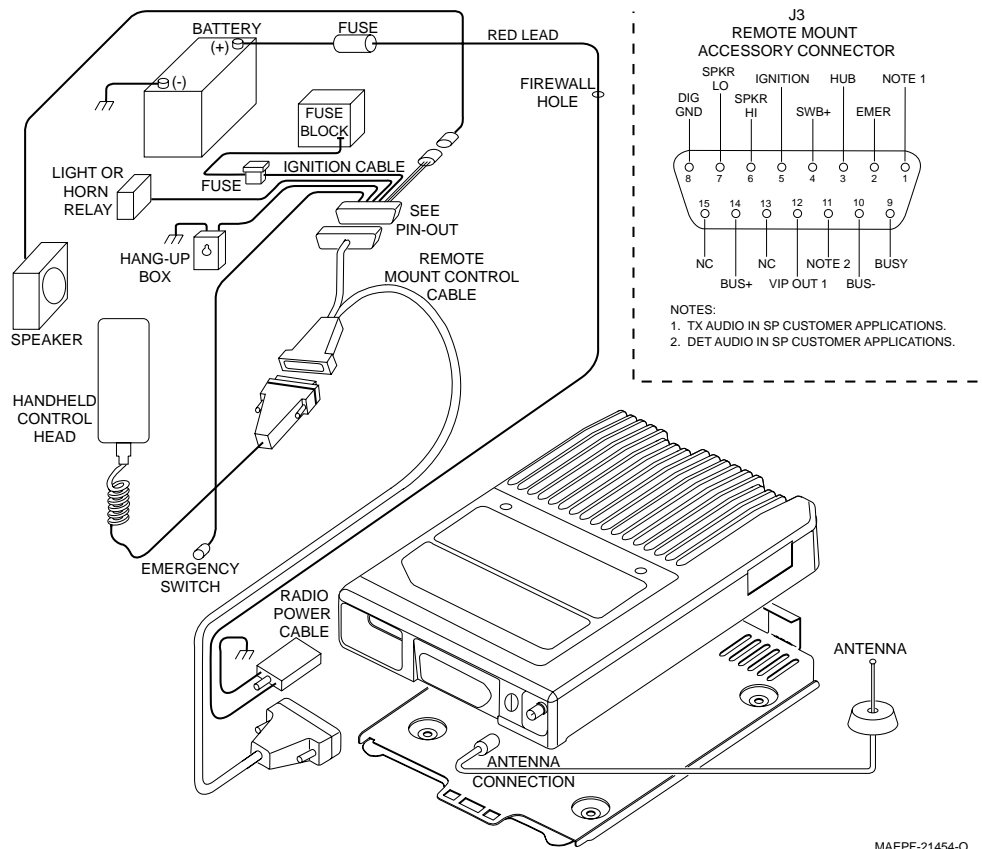

Figure 3 High-Power Radio Installation (Remote) Using A3 Control Heads

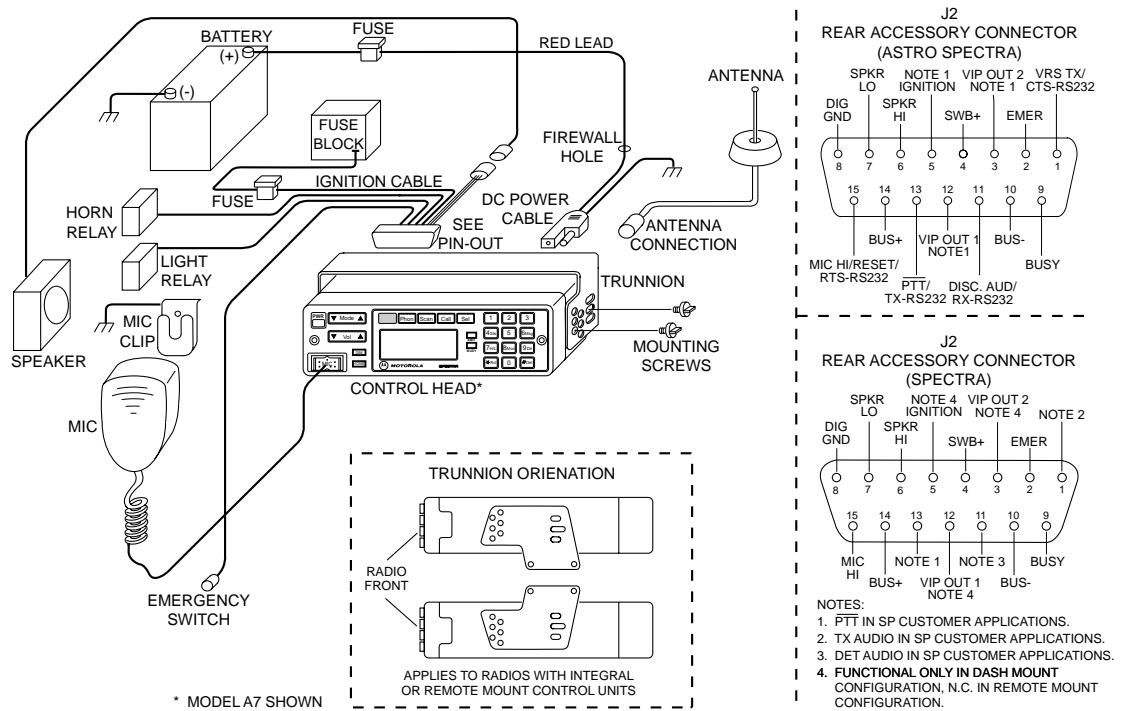

Figure 4 Low-/Mid-Power Radio Installation (Dash Mount) Using A4, A5, or A7 Control Heads

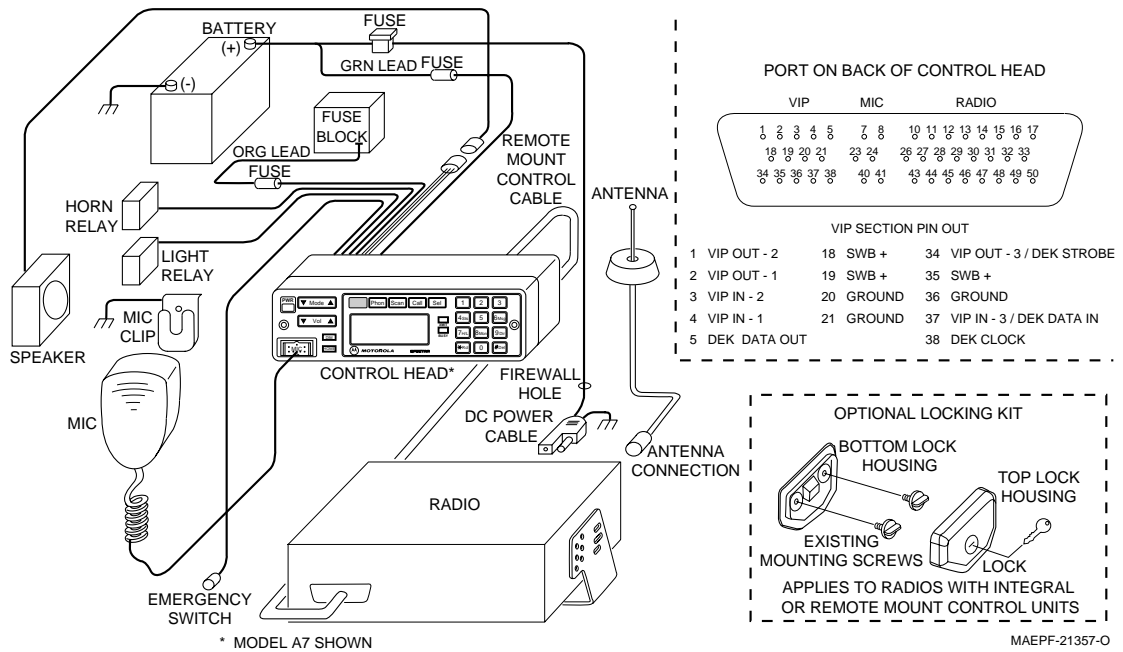

Figure 5 Low-/Mid-Power Radio Installation (Remote) Using A4, A5, A7 or A9 Control Heads

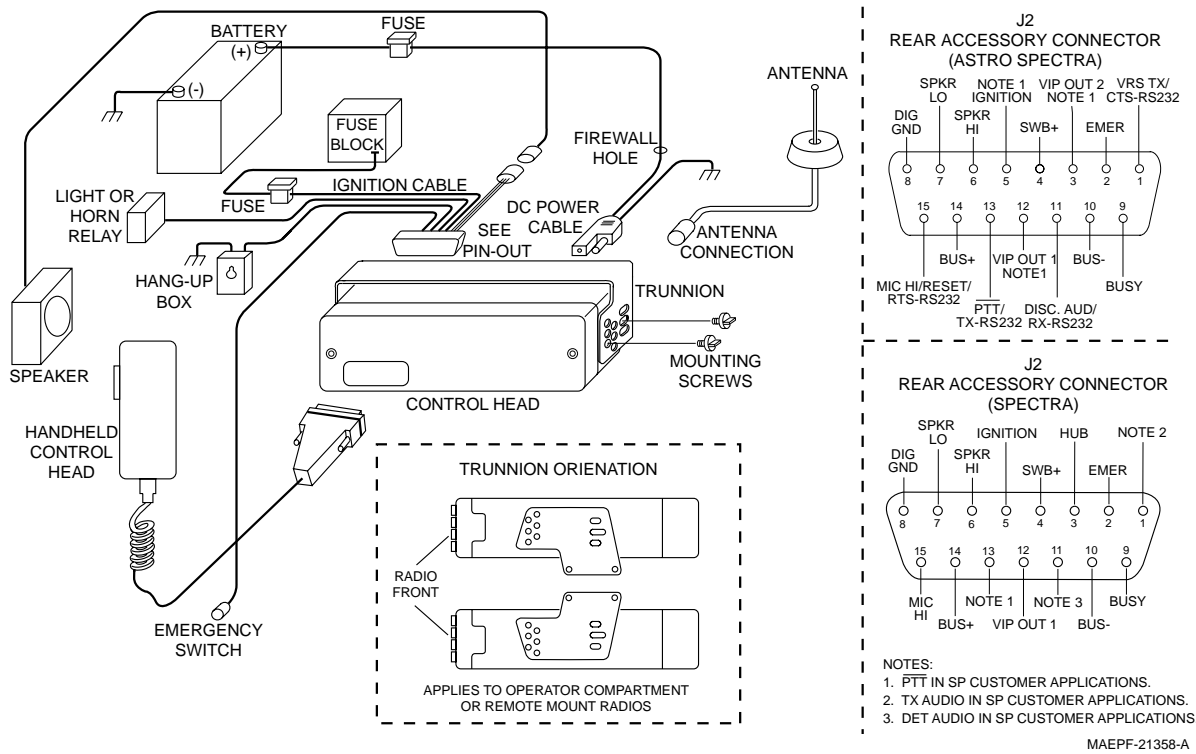

Figure 6 Low-/Mid-Power Radio Installation (Dash Mount) Using A3 Control Heads

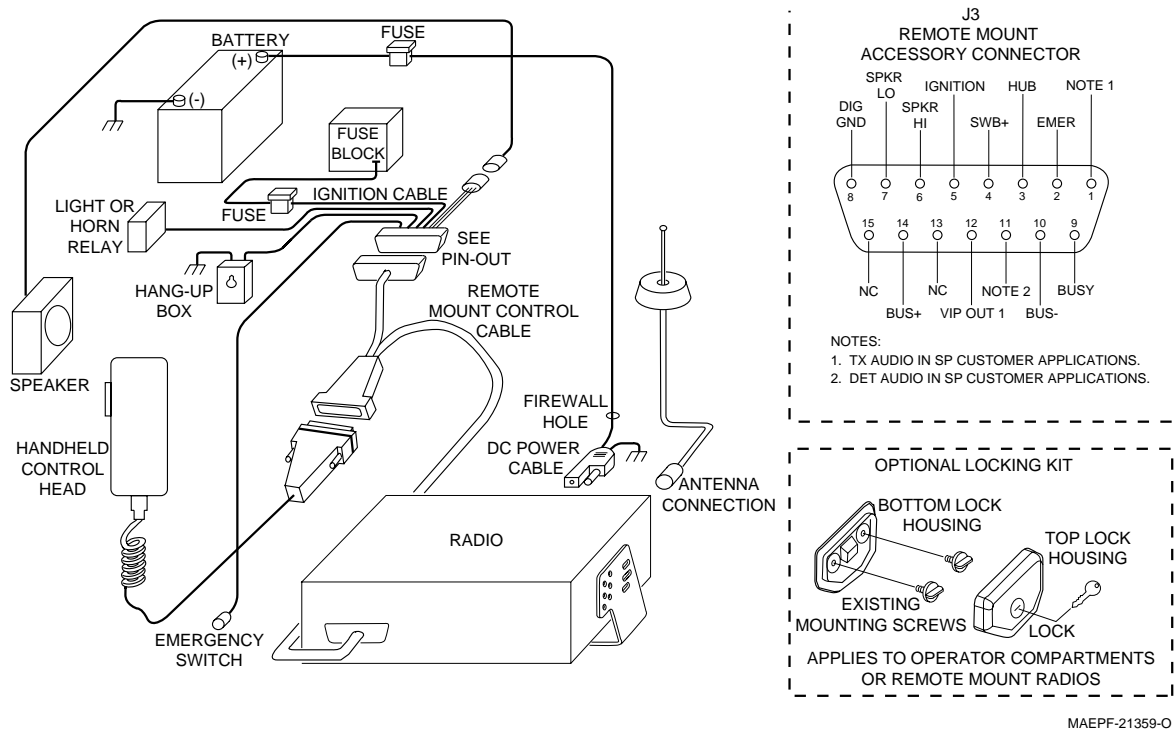

Figure 7 Low-/Mid-Power Radio Installation (Remote) Using A3 Control Heads

Microphone Hang-up Clip Installation

The hang-up clip must be within reach of the operator(s). Measure this distance before actually mounting the bracket. Since the bracket has a positive-detent action, the microphone can mount in any position. The microphone hang-up clip must be grounded.

Use the hang-up clip as a template to locate the mounting holes. To avoid interference when removing the microphone, install the flathead screw in the top clip hole.

Handheld Hang-up Box Installation (A3 Model Control Head)

Use the hang-up box (HUB) as a template to locate the mounting holes. Be sure the HUB will be within easy reach of the operator. Route the control wire with the male pin to the accessory cable connector at the rear of the radio or cable harness as shown in Figures 6 and 7. Open the accessory cable connector and connect the HUB control wire to location 3 of the accessory connector. Connect the other control wire from the HUB to a convenient solid chassis ground point.

Low-/Mid-Power Radio Power Cable Installation

Route the red radio power cable from the radio to the vehicle's battery compartment, using accepted industry methods and standards. Be sure to grommet the firewall hole to protect the cable. Remove the 15-amp (P/N 6580283E06) fuse from the fuseholder and connect the red lead of the radio power cable to the positive battery terminal using the hardware provided as shown in 8. Connect the black lead to a convenient solid chassis ground point. **DO NOT** connect the black lead directly to the battery's negative terminal.

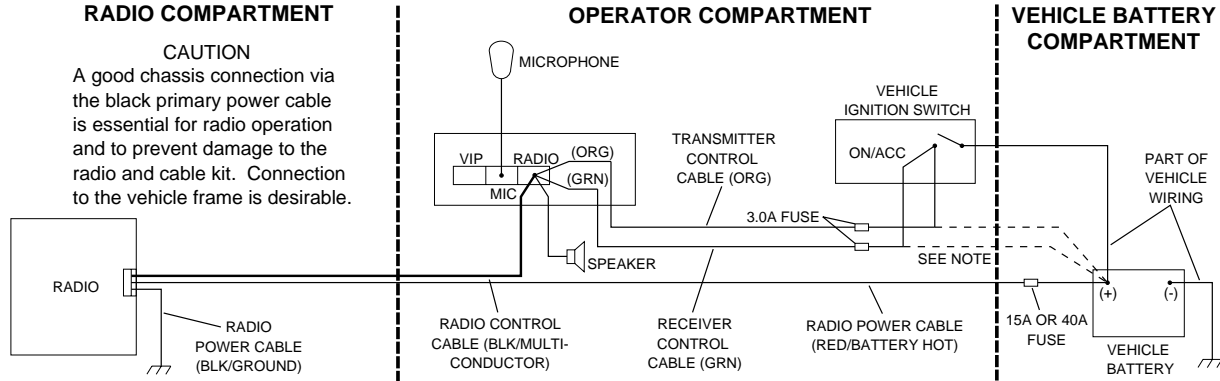

NOTE:

The orange and green power cables connect to either the vehicle battery or the ignition switch. Connect the green cable directly to the battery. The receiver operates when the control head is on. Connect the orange cable to the ignition switch. The transmitter operates only when the ignition switch is on. Alternate connections-Connecting both green and orange cables to the battery allows the control head to turn the receiver and transmitter on or off. Connecting both green and orange cables to the ignition switch allows the ignition switch to turn the receiver and transmitter on or off. (Alternator whine and other noise problems may occur. Isolate the green cable with a Motorola relay, part #59-00813674.)

Figure 8 Cabling Interconnect Diagram

High-Power Radio Power Cable Installation

As shown in Figure 8, route the bare end of the red radio power cable from the radio to the vehicle's battery compartment, using accepted industry procedures and standards. Be sure to grommet the firewall hole to protect the cable. After the long cable has been routed to the battery compartment, decide on a location for the fuse retainer. When choosing this location, consider ease of checking and replacing fuses. This location should also be as close to the battery as possible for better protection of the radio and cabling.

Remove the fuse from the fuseholder and connect the short red cable with the fuse connection to the positive battery terminal. Cut the long red radio power cable to the proper length and strip the red insulation back 3/4" from the end. Slide the heat-shrink tubing provided with the equipment over the cable. Insert the stripped end into the fuse receptacle (assembly shown in Figure 9), and solder it for a good electrical connection. After soldering has been completed, slide the heat-shrink tubing over the solder joint and apply heat. **DO NOT** install the fuse until instructed to do so.

Connect the red cable from the fuseholder to the positive battery terminal. Connect the black radio power lead, from the radio, to a good ground connection on the vehicle chassis. **DO NOT** connect the black radio power lead directly to the battery's negative terminal.

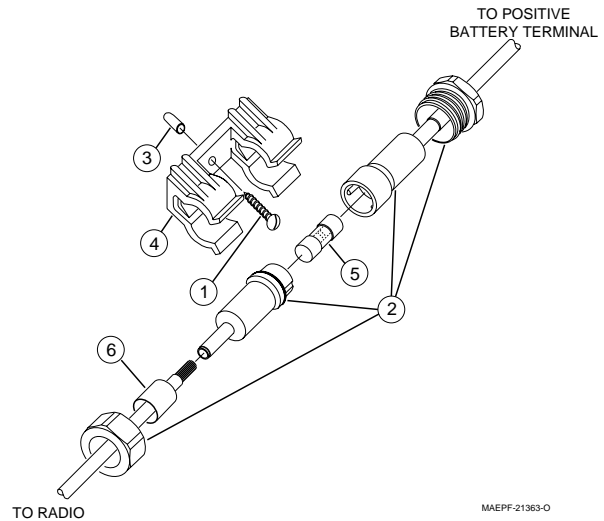

Figure 9 High-Power Main Fuse Assembly (40-Amp)

**Exploded View Parts List
Fuse Assembly for High-Power Main Fuse (40-Amp)**

REFERENCE SYMBOL	MOTOROLAP ART NO.	DESCRIPTION
1	0300139931	SCREW
2	0984277B02	RECEPTACLE, Fuse
3	3884383D02	CAP, Protective
4	4284275B01	FUSE, Retainer
5	6584161B01	FUSE, 40-Amp (5AG)
6	3700134371	TUBING, Heat-Shrink

Remote Radio Control Cable Installation

The radio control cable should go from the rear of the control head to the radio. Route the cables in the vehicle's wiring troughs (where available) or route the cables where they are protected from pinching, sharp edges, or crushing. One suggested route is along one side of the driveshaft hump under the carpet. Use grommets in any holes where the cable passes through metal panels. Figure 8 shows how the cables and components are connected.



Caution

To ensure a proper water seal, the jackscrews on the radio cable connector must be tight. If the accessory port on a remote mounted radio is not used, the cover gasket assembly (HLN6233_) must be installed and torqued to 6 to 8 inch-pounds.

Dash Mount Radio Installation



Caution

DO NOT mount the radio on a plastic dashboard without first reinforcing the dashboard; the weight of the radio may crack or break the dashboard.

DO NOT mount the radio on a flat or concave surface where the radio could be partially submersed in water. This is especially important if the cab area of the vehicle is cleaned by spraying with water. If the radio sits in water for a length of time, moisture will seep inside the radio and damage the electronic components.

DO NOT allow water to stand in recessed areas of vertically mounted radios. Remove any moisture immediately to prevent it from seeping down into the radio.

The mounting location must be accessible and visible. Select a location that will permit routing the RF antenna cable as directly as possible. See Figures 4 and 6 for typical dash mount radio installations.

NOTE: For optimum radio performance, orient the mounting trunnion as shown in Figures 4 and 6.

Use the radio's mounting trunnion as a template to mark the mounting hole locations. Fasten the trunnion to the dash (or on the transmission hump) using the self-drilling screws provided.

Locking Kit Installation (Optional)

If a locking kit is used (shown in Figures 5 and 7) position the lock bottom housing on the trunnion before installing the radio mounting screws. Then slip the top lock housing on and remove the key. You can install the lock on either side of the radio, and by rotating it 180°, you can also install it on dash installations.

Complete the installation by mounting the radio in its trunnion, connecting the speaker and power wires, and plugging in the microphone cable/handheld control unit.

Remote Mount Low-/Mid-Power Radio Installation



Caution

DO NOT mount the radio on a plastic dashboard without first reinforcing the dashboard; the weight of the radio may crack or break the dashboard.

DO NOT mount the radio on a flat or concave surface where the radio could be partially submersed in water. This is especially important if the cab area of the vehicle is cleaned by spraying with water. If the radio sits in water for a length of time, moisture will seep inside the radio and damage the electronic components.



DO NOT allow water to stand in recessed areas of vertically mounted radios. Remove any moisture immediately to prevent it from seeping down into the radio.

Caution

For radios equipped with optional remote mount control heads, see Figure 5. For radios equipped with remote handheld control heads, see Figure 7. Choose a mounting location for the radio, considering accessibility, and control and antenna cable lengths.

NOTE: For optimum performance, orient the mounting trunnion as shown in Figures 5 and 7. Also, if an optional locking kit is used, position the lock bottom housing on the trunnion before installing the radio mounting screws. Then slip the top lock housing on and remove the key. You can install the lock on either side of the radio.

Use the radio's mounting trunnion as a template to mark the mounting hole locations. Use the self-drilling screws provided to fasten the trunnion. Install the radio and fasten it to the trunnion with the wing screws provided.

Remote Mount High-Power Radio Installation



Caution

DO NOT mount the radio on a plastic dashboard without first reinforcing the dashboard; the weight of the radio may crack or break the dashboard.

DO NOT mount the radio on a flat or concave surface where the radio could be partially submersed in water. This is especially important if the cab area of the vehicle is cleaned by spraying with water. If the radio sits in water for a length of time, moisture will seep inside the radio and damage the electronic components.

DO NOT allow water to stand in recessed areas of vertically mounted radios. Remove any moisture immediately to prevent it from seeping down into the radio.

Choose a mounting location for the radio, considering accessibility, and control and antenna cable lengths. With the radio appropriately located, use the radio mounting tray as a template to mark the mounting hole locations.

NOTE: For optimum performance, orient the mounting tray and radio as shown in Figures 2 and 3.

Use the self-drilling screws provided to fasten the mounting tray. Install the radio and fasten it to the tray by aligning the radio to the tray with the handle to the front (see Figures 2 and 3). Insert the key into the lock and turn it clockwise to release the handle. Apply a downward force at the front sides of the radio while sliding the radio back into the tray.

When the radio is in place, it can be locked into position by lifting the handle into the upright position. The lock should "click" when the handle is caught by the lock. Ensure proper locking engagement by attempting to lift the radio out of position.

Remote A4, A5, A7, and A9 Model Control Head Installation

The recommended mounting surfaces for the control unit are under the dashboard, on the transmission hump, or on the center console. Figure 10 shows an example of the A4, A5, and A7 control heads. Figure 12 shows how the bracket, control head, and cables should be installed for the A9 model control head.

NOTE: *For Control Head Models A4, A5, and A7 only:* To seal the control head and meet U. S. MIL-STD-810D environmental specifications, covers are supplied for protection of the control head's rear connector pins. These covers are in the bag that is fastened to the remote control head's mounting trunnion.

If the VIP connector is not being used to connect options, the VIP protective cover should be installed as shown in Figure 11. If the microphone is connected to the front of the control head, the MIC protective cover should be installed as shown in Figure 11. Alternately, the microphone can be connected to the rear connector in place of the cover, and the control head will still be environmentally sealed.

An adjustable trunnion, which allows a number of mounting positions, is supplied for mounting the control unit. The installation must not interfere with the operation of the vehicle or its accessories, nor disturb passenger seating or leg room. The control head must be within convenient reach and viewing of the user(s).

Although the trunnion can be mounted on a plastic dashboard, all four mounting screws should penetrate the dashboard's supporting metal frame. If that is not possible, use a metal backing plate (not supplied) to strengthen the installation. Install the control unit as follows:

1. Use the control unit trunnion as a template to mark the mounting holes; drill 5/32" holes. If mounting on a plastic surface, use a metal backing plate.
2. Attach the trunnion bracket using all four 10–16" x 5/8" self-tapping screws provided.

NOTE: When the control unit is installed, it must not wobble or feel "spongy" when you press the buttons. Use all four mounting screws and be sure they are tightly screwed into metal – either a dashboard support bracket or a backing plate.

3. Temporarily install the control head (adjusting for proper viewing angle) and fasten it to the trunnion with two wing screws. Test the installation to be sure the unit does not wobble or feel "spongy" when you press the buttons.



Caution

Care must be taken to shield the control head (front and back) from a direct exposure of pressurized water. The pressurized water from a hose, in most cases, is more severe than the stated test and conditions in typical environments.

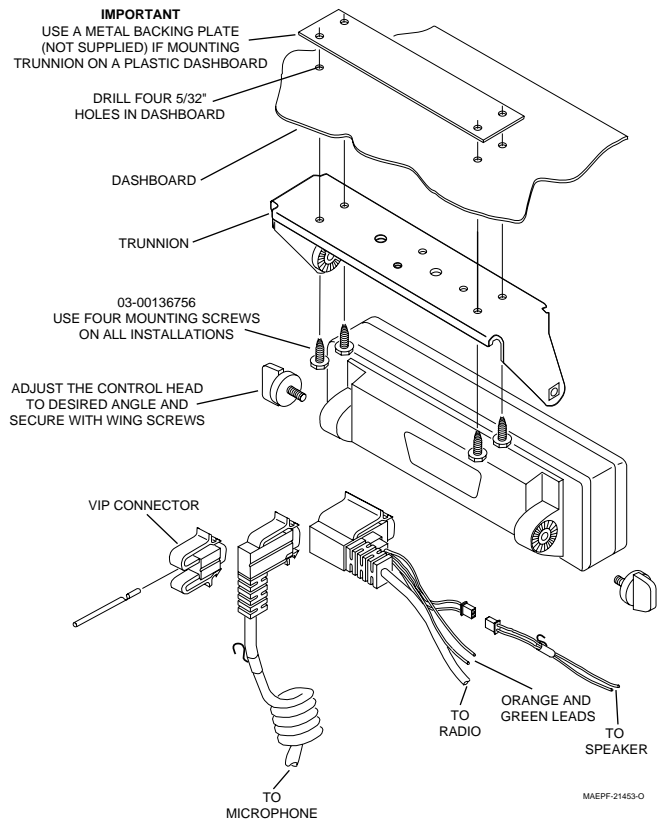

Figure 10 A4, A5, and A7 Control Head Installation Exploded View

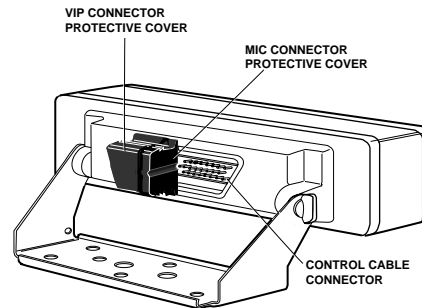

Figure 11 A4, A5, and A7 Control Head Rear View

Remote A3 Model Control Head Installation

For the remote handheld control unit, mount the control cable with the screws provided. Connect the control cable as shown in Figure 7. Connect the speaker to the accessory cable harness.

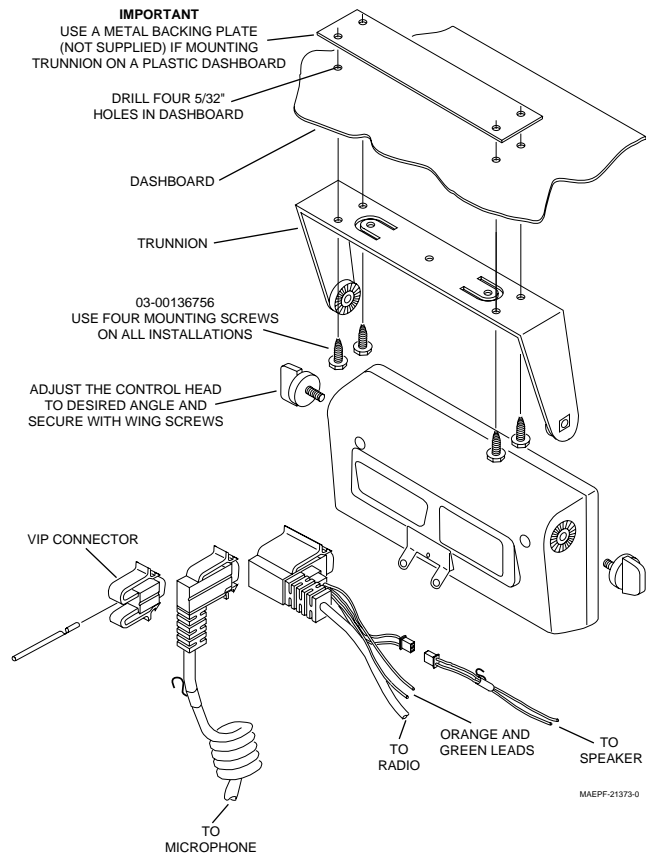

Figure 12 A9 Control Head Installation Exploded View

Transmit/Receive Control Cable Installation (A4, A5, A7, and A9 Remote Control Heads)

The radio system includes two separate wires, one orange (66") and one green (106"). The HLH4952A Fuse Kit contains crimp-on ring tongue lugs and crimp-on spade lugs. The spade lugs allow connection to hot leads at the fuse block of the vehicle, and the ring tongue lugs permit attachment to screw terminals. Determine from Table 1 which radio functions are to be switched through the vehicle ignition switch.

A typical system allows the receiver to operate with the radio switched on while the ignition switch is in the off position, but the transmitter will not operate unless the ignition switch is in the on position. In this case, connect the orange wire to the accessory terminal of the ignition switch and the green wire to the ungrounded terminal of the battery or starter solenoid.



Caution

DO NOT connect either lead to the ungrounded terminal of the battery at this time.

Table 1 Radio Functions Connections

Conductor	Green	Orange	Green	Orange	Green	Orange
Connected to battery	X	X	X			
Connected to ignition switch				X	See Note	X
Ignition switch controls	No ignition switch control		Transmitter ignition switch controlled		Complete radio ignition switch controlled	
In any application, trim and strip wires. Crimp on ring lug for battery connections. For ignition switch connections, crimp on ring or spade lug (whichever is required).						

Note: In cases where alternator whine or interference is a problem, isolate the green lead with a relay (Motorola Part No. 5900813674) (see Figure 13).

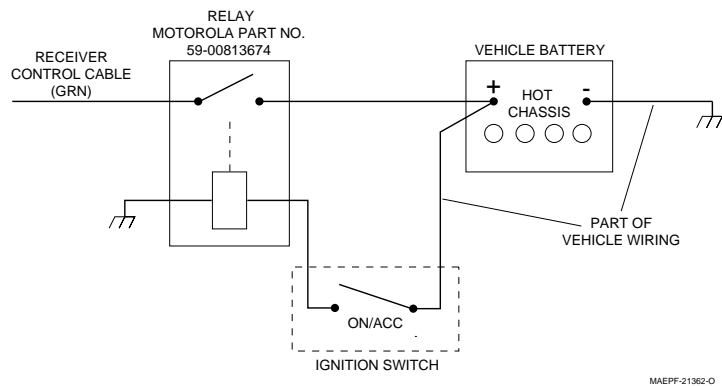

Figure 13 Alternator Whine Suppressor Isolation Detail

If either wire is to be connected in the vehicle's battery compartment, pass the end of the wire through the same firewall hole that the red radio power cable uses. At this point, install a fuseholder assembly in both wires (shown in Figure 14); the following procedures apply to both green and orange wires:

- A fuse will need to be placed in-line for both the orange and green wires; consideration should be taken when deciding where to place the fuses so that they are easy to inspect. However, they should also be placed as close as possible to the battery or the vehicle's ignition switch terminal.
- After choosing the fuse locations, the fuse receptacles need to be installed. This is done by cutting the wire at the chosen location and stripping 1/8-inch of insulation on all loose ends. Make sure the wire will reach its intended destination.
- On the end still connected to the cable kit, slide the plastic insulator fuseholder over the wire as shown in Figure 9. Insert the stripped end of that wire into one of the metal fuse clips, and crimp it closed onto the exposed wire. Solder it for a better electrical contact.
- On the end of the loose wire, repeat the above crimping and soldering process with the remaining metal fuse clip.

- Temporarily, install the fuse (both are 3-amp), into the fuse clips onto both sides of the fuse. Slide the spring over the remaining loose end of the wire. The spring should be followed by the plastic insulator fuseholder oriented as shown in Figure 10. Slide the plastic insulator fuse holder together, by first making sure the spring slips inside the plastic insulator fuseholder cap. Now, twist the fuseholders until they lock together. After assembly proves successful, remove the fuses until instructed to install them later.

With the spring and plastic insulator fuseholder cap still in place on the loose portion of the wires (orange and green), insert the stripped end of the wire into the spade or ring tongue lug. Crimp and solder the lug as was done on the metal fuse clips above.

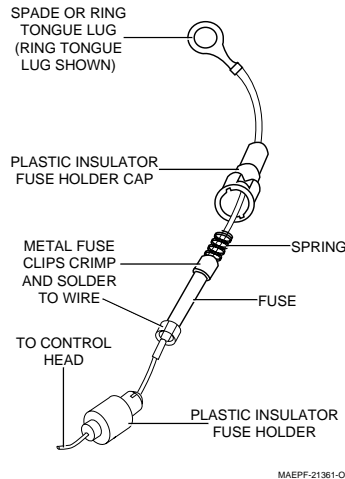

Figure 14 Fuseholder Assembly and Parts List for Orange and Green Control Cables

Parts List

Fuse Assembly for Orange and Green Leads

MOTOROLA PART NO.	DESCRIPTION
1482882A01	INSULATOR, Fuseholder Body
1482883A01	INSULATOR, Fuseholder Cap
2900136968	LUG
2900824456	LUG, Ring Tongue
2900865065	LUG, Ring Tongue
4182885A01	SPRING, Compression; Fuse
4282884Q01	CLIP, Fuse
6500020404	FUSE, 3-Amp 250V (Qty. 2)

Transmitter Control Power Lead (Orange)

Connect the orange lead to the ignition switch (recommended) or directly to the battery hot supply (see Figure 8).

Receiver Control Power Lead (Green)

Connect the green lead to the positive battery terminal (recommended) or the ignition switch (see Figure 8). When alternator whine or interference is a problem, Figure 13 shows an alternate power control isolation method of wiring the green lead.

Ignition Cable (for Remote A3 Control Heads and Dash Mount Radios)

For radio ON/OFF control independent of the ignition switch, connect the red ignition switch (pin 5 of accessory connector) to “battery hot” at the vehicle fuse block.

For radio ON/OFF control via the ignition switch, connect the red ignition cable to “ignition” at the fuse block.

For other considerations when connecting the ignition cable, see the service manual.

Alternator Whine Suppressor Installation

Occasionally, an installation may have an objectionable high level of alternator whine. This may be due to the age and condition of the vehicle’s battery, alternator, or wiring. Filters, switching relays and special cables are available to reduce the problem. Figure 13 shows an alternate power control isolation method of wiring the green lead (used when alternator whine or interference is a problem).

Antenna Installation

IMPORTANT NOTE: To assure optimum performance and compliance with RF Energy Safety standards, these antenna installation guidelines and instructions are limited to metal-body vehicles with appropriate ground planes and take into account the potential exposure of back seat passengers and bystanders outside the vehicle.

NOTE: For mobile radios with rated power of 7 watts or less, the only installation restrictions are to use only Motorola approved antennas and install the antenna externally on metal body vehicles. For mobile radios with rated power greater than 7 Watts, always adhere to all the guidelines and restrictions in the section below.

Selecting an Antenna Site/Location on a Metal Body Vehicle

1. External Installation—Check the requirements of the antenna supplier and install the vehicle antenna external to a metal body vehicle in accordance with those requirements.
2. Roof Top—For optimum performance and compliance with RF Energy Safety Standards, mount the antenna in the center of the roof.
3. Trunk Lid—On some vehicles with clearly defined, flat trunk lids, the antennas of some radio models (see restrictions below) can also be mounted on the center area of the trunk lid. For vehicles without clearly defined, flat trunk lids (such as hatchback autos, sport utility vehicles, and pick-up trucks), mount the antenna in the center of the roof.

BEFORE INSTALLING AN ANTENNA ON THE TRUNK LID,

- Be sure that the distance from the antenna location on the trunk lid will be at least 85 cm (33 inches) from the front surface of the rear seat-back to assure compliance with RF Energy Safety standards.
- Ensure that the trunk lid is grounded by connecting grounding straps between the trunk lid and the vehicle chassis.

NOTE: If these conditions cannot be satisfied, then mount the antenna on the roof top.

4. Ensure the antenna cable can be easily routed to the radio. Route the antenna cable as far away as possible from the vehicle electronic control units and associated wiring.
5. Check the antenna location for any electrical interference.
6. Make sure the mobile radio antenna is installed at least 30 centimeters (1 foot) away from any other antenna on the vehicle.
7. For XPR Series Mobile Radio models with GPS using a GPS only or a combined RF/GPS antenna, ensure that the antenna has a clear view of the sky and that the antenna base with the GPS receiver is not covered by any metallic or radio frequency absorbing material. Any non-glass-mount GPS antenna should be positioned next to the RF antenna. Any other mobile radio antenna should be at least 30 centimeters (1 foot) away from the RF antenna.

NOTE: Any two metal pieces rubbing against each other (such as seat springs, shift levers, trunk and hood lids, exhaust pipes, etc.) in close proximity to the antenna can cause severe receiver interference.

Antenna Installation Procedure

1. Mount the antenna according to the instructions provided with the antenna kit. Run the coaxial cable to the radio mounting location. If necessary, cut off the excess cable and install the cable connector.
2. Connect the antenna cable connector to the radio antenna connector on the rear of the radio.
3. In case of a GPS model, connect the GPS antenna to the GPS antenna connector on the rear of the radio.

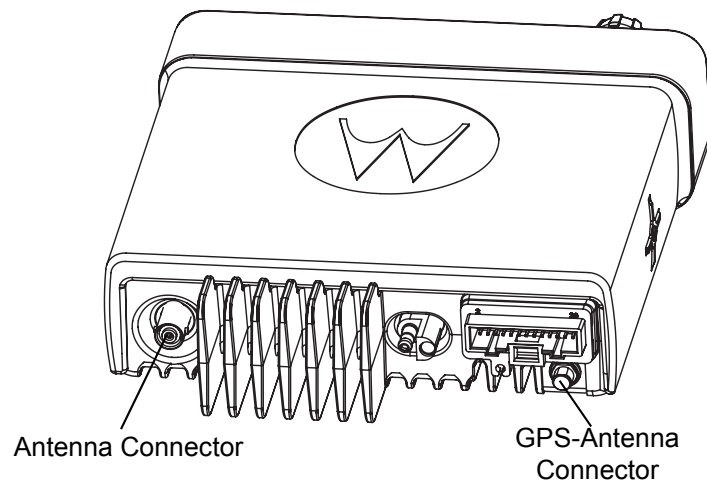

Figure 15 Antenna connections on the back of the radio

Antenna Connection

To ensure a secure connection of an antenna cable's mini-UHF plug to a radio's mini-UHF jack, their interlocking features must be properly engaged. If they are not properly engaged, the system will loosen.

NOTE: Applying excessive force with a tool can cause damage to the antenna or the connector (e.g., stripping threads, deforming the collar or connector, or causing the connector to twist in the housing opening and break).

Motorola recommends the following sequence to ensure proper attachment of the system (see Figure 3-10):

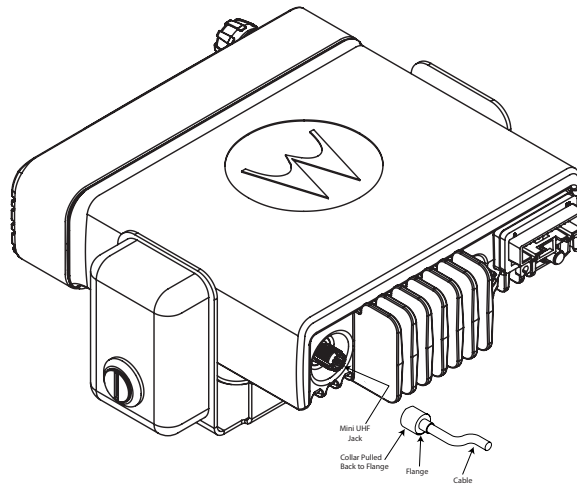

Figure 16 Mini-UHF Connection

1. Make sure that there is sufficient slack in the antenna cable.
2. Make sure that the collar of the antenna cable plug is loose and does not bind.
3. Slide the collar back against the flange. Insert the antenna cable plug's pin fully into the radio jack, but do not engage the threads.
4. Ensure that the plug's and jack's interlocking features are fully seated. Check this by grasping the crimp on the cable jack, rotating the cable, and noting any movement. If the features are seated correctly, there should be NO movement.
5. Finger-tighten the antenna cable plug's collar onto the radio's jack.
6. Give a final tug, by hand, to the collar, and retighten by hand as firmly as possible.
7. Use the rubber-coated pliers to grip the plug's knurled collar, then turn clockwise to tighten the collar. It should take 1/4 turn or less. Turning counterclockwise loosens the collar.

NOTE: Overtightening the collar can damage the connector and the radio.

Phone Button Key Installation

For radios equipped with telephone interconnect, a "PHON" button is included with the order. If the customer wishes to utilize this feature, pry out the black plug at the control unit position shown in Figure 17, then push the **PHON** button into its place.

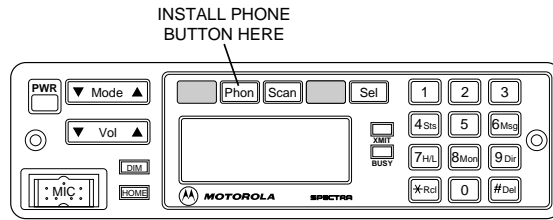

MAEPF-21423-O

Figure 17 Installing the Phone Button Key on A4, A5, and A7 Model Control Heads

Options and Accessories Installation for A4, A5, A7, and A9 Model Control Heads

The vehicle interface port (VIP) allows the control head to operate outside circuits and to receive inputs from outside the control head. There are three VIP outputs which are used for relay control. There are also three VIP inputs which accept inputs from switches. See the cable kit section for typical connections of VIP input switches and VIP output relays.

VIP Output Connections

The VIP output pins are on the back of the control head. The pin information is shown in Figures 2, 4, and 5. Use these connections to wire control relays. One end of the relay should connect to switched B+ voltage, while the other side connects to a software controlled **ON/OFF** switch inside the control head. The relay can be normally on or normally off depending on the configuration of the VIP outputs. The control head has three VIP output connections shown as follows:

Output Number	SW B+ Pin Number	On/Off Switched Pin Number
1	18	2
2	19	21
3	35	34

The function of these VIP outputs can be field programmed in the control head. Typical applications for VIP outputs are external horn/lights alarm and horn ring transfer relay control. For further information on VIP outputs, see the control head programming manual.

VIP Input Connections

The VIP input pins are on the back of the control head. These connections control inputs from switches. One side of the switch connects to ground while the other side connects to a buffered input to the control head. The switch can be normally closed (NC) or normally open (NO) depending on the configuration of the VIP inputs. The control head has three VIP input connections shown as follows:

Input Number	Ground Pin Number	On/Off Switched Pin Number
1	20	4
2	21	3
3	36	37

Emergency Pushbutton, Footswitch, Horn Relay, and Light Relay Installation

Perform the following installation procedure:

1. Select an appropriate place to mount the option or accessory hardware.
2. Connect male-pin control leads (wires) to the VIP connector in the appropriate location (see Output/Input Connections tables above). Figure 18 shows how wires are plugged into the connector and how to use an extraction tool to remove wires.
3. Route the accessory-to-control head cables under floor coverings or behind panels so that the vehicle occupants do not snag or break the wires.

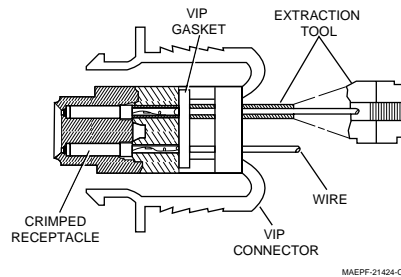

Figure 18 VIP Connector Detail

Emergency Pushbutton or Footswitch Installation

Mount the switch using the hardware that comes with the kit. Connect the emergency switch wires to a ground pin and a VIP IN pin on the VIP connector.

Horn (External Alarm) Relay Installation

Mount the horn relay in a suitable location (normally under the dash). Connect the relay contacts across the horn ring switch, typically found in the steering column. Connect the two control wires to a SW B+ pin and a VIP OUT pin on the VIP connector.

Lights (External Alarm) Relay Installation

Mount the light relay in a suitable location (normally under the dash). Connect the relay contacts across the headlamp ON/OFF switch. Connect the two control wires to a SW B+ pin and a VIP OUT pin on the VIP connector.

Options and Accessories Installation

ASTRO Digital Spectra radios and Spectra radios equipped with the following features are capable of transmitting automatically, even if the radio is turned off:

- MDC Status/Message
- MDC Emergency
- Trunking Products
- Automatic Vehicle Location
- Other Special Data Products



Caution

All ASTRO Digital Spectra radios and Spectra radios have accessory connector pins 2 and 8 connected together to allow the radio to power down. Opening this connection by REMOVING the accessory connector, or otherwise failing to maintain a normally closed path, could, if left unchecked, drain the vehicle battery, and possibly cause transmissions to occur.

To install an option or accessory perform the following installation procedure:

1. Select an appropriate place to mount the option or accessory hardware.
2. Connect male pin control leads (wires) to the accessory cable connector in the appropriate location.
3. Route accessory-to-control head cables under floor coverings or behind panels so that the vehicle occupants do not snag and break the wires.

For A3 model control heads, pin information is included in Figures 3, 6, and 7.

MDC Emergency Pushbutton or Footswitch Installation

Mount the footswitch using the hardware that comes with the kit. Open the accessory cable connector housing; remove the jumper wire. Connect the emergency switch wires to pins 2 and 8 (see Figure 19). Close the connector housing; route the finished cable from the switch location to the control head location.

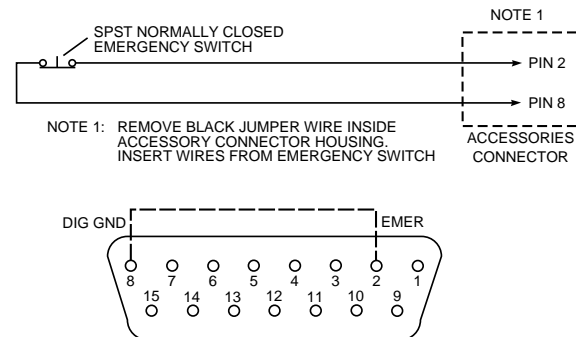

Figure 19 Emergency Switch Wiring Diagram

Horn and Lights (External Alarms) Relays

For installations that use the horn/lights option, select a suitable location for mounting (normally under the dash) and, referring to Figure 20, perform the following procedure:

NOTE: The handheld control head can have a horn or light option, but not both. Control wires for either option should be connected to pins 12 and 4 of the accessory connector.

1. Horn Relay—Connect the relay contacts across the horn ring switch, typically found in the steering column. Open the accessory cable connector and connect the two control wires (male pins) into locations 12 and 4 of the connector.

2. Lights Relay—Connect the relay across the headlamp ON/OFF switch, typically found in the steering column. Open the accessory cable connector and connect the two control wires (male pins) into locations 3 and 4 of the accessory connector.

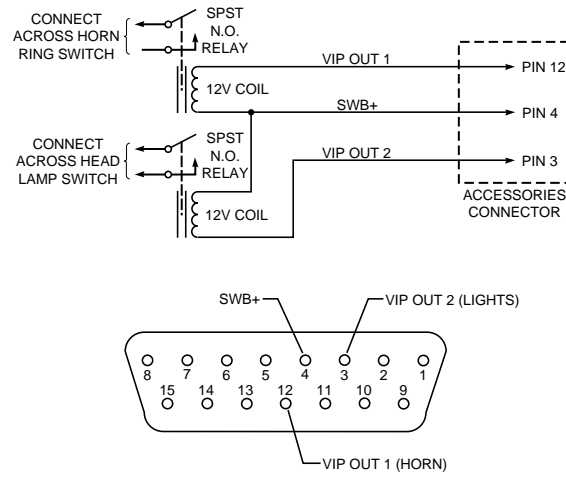

Figure 20 Horn/Light Wiring Diagram

Connecting Cables

Perform the following if it has not been previously done:

1. For all models except A3, remove the control head from its mounting trunnion. Plug the radio's control cable into the proper location on the back of the control head. (See Figures 10 and 12.) The connectors "click" when snapped into place. A4, A5, and A7 control head models can have the microphone plugged into either the lower left corner of the control head front panel or in the middle section of the connector on the rear of the control head. A9 control head models have only the rear connection on the control head available. Connect the microphone cable S-hook into the hole in the cable strain relief bracket on the back of the control head (A9 model) or on the mounting trunnion (A4, A5, and A7 models).
2. Connect the plug from the speaker lead to the mating connector coming out of the control cable connector or accessory cable harness (A3 model).
3. Plug the VIP connector into the remaining location on the back of the control head.
4. Connect the control cable to the radio and tighten the connector by tightening the jack screws.



Caution

To ensure a proper water seal, the jackscrews on the radio cable connector must be tight. If the accessory port on a remote-mounted radio is not used, the cover gasket assembly (HLN6233_) must be installed and torqued to 6 to 8 inch-pounds.

5. Be sure the control head and microphone PTT switches are OFF. Install the fuse (15-amp for low/mid power and 40-amp for high power) in the radio power cable fuseholder and the 3-amp fuse(s) in the ignition cable fuseholder(s).
6. Turn the radio ON at the control head and verify proper operation of all controls and indicators. Radio operation in some installations require turning on the ignition. Perform a complete operational check of the radio.
7. Dress the control and power cables out of the way to prevent damage (pull any excess cable into the trunk area) securing with clamps and tie wraps where necessary.

REPLACEMENT PARTS ORDERING

ORDERING INFORMATION

When ordering replacement parts or equipment information, the complete identification number should be included. This applies to all components, kits, and chassis. If the component part number is not known, the order should include the number of the chassis or kit of which it is a part, and sufficient description of the desired component to identify it.

Crystal orders should specify the crystal type number, crystal and carrier frequency, and the model number in which the part is used.

MAIL ORDERS

Send written orders to the following addresses:

Replacement Parts/
Test Equipment/Manuals/
Crystal Service Items:

Motorola Inc.
United States and Canada
Accessories and Aftermarket
Division
Attention: Order Processing
1313 E. Algonquin Road
Schaumburg, IL 60196

Federal Government Orders:

Motorola Inc.
United States and Canada
Accessories and Aftermarket
Division
Attention: Order Processing
7230 Parkway Drive
Landover, MD 21076

International Orders:

Motorola Inc.
United States and Canada
Accessories and Aftermarket
Division
Attention: International Order
Processing
1313 E. Algonquin Road
Schaumburg, IL 60196

TELEPHONE ORDERS

United States and Canada Accessories and Aftermarket Division:
Call: 1-800-422-4210
1-800-826-1913 (For Federal Government Orders)
1-847-538-8023 (International Orders)

Servicers Training (VHS Video Tapes):
Call: 847-576-2828

FAX ORDERS

United States and Canada Accessories and Aftermarket Division:
FAX: 847-538-8198 (Domestic)
847-576-3023 (International)
Parts ID: 847-538-8194

Federal Government Orders:
FAX: 410-712-4991
International: 410-712-6200

PARTS CUSTOMER SERVICE

United States and Canada Accessories and
Aftermarket Division:
Call: 1-800-422-4210
Parts Identification:
Call: 847-538-0021

PRODUCT CUSTOMER SERVICE

Customer Response Center
(Sales and Service Assistance):
Call: 1-800-247-2346
FAX: 1-800-232-9272

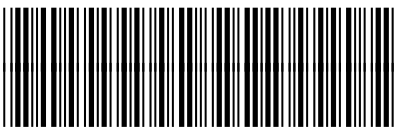

68P81070C85-D

Motorola
8000 West Sunrise Boulevard
Fort Lauderdale, Florida 33322