

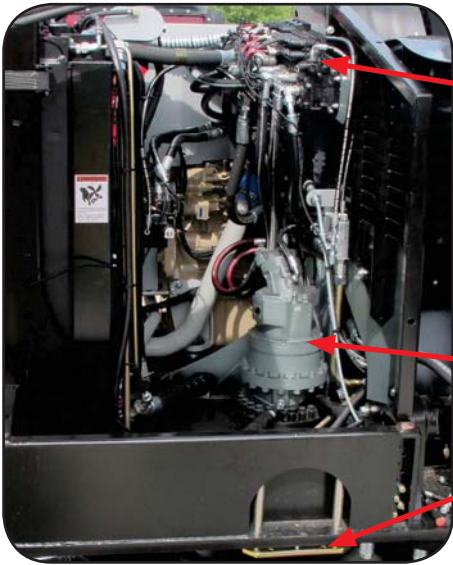

725-C
735-C
745-C





Better Access to Critical Components

Better Access to Control Valve

Isolated Electrical Compartment for ease of Service and added protection.

Better Access to Swing Motor

Retractable Front Step for Service



Rubber Belting Protection Added to Boom and Gullwing to Reduce Debris in Engine and Hydraulic Compartments.

High Temperature Wrap on Exhaust and Heat Shields on Manifolds

Energy Recovering Hydrostatic Swing Pump

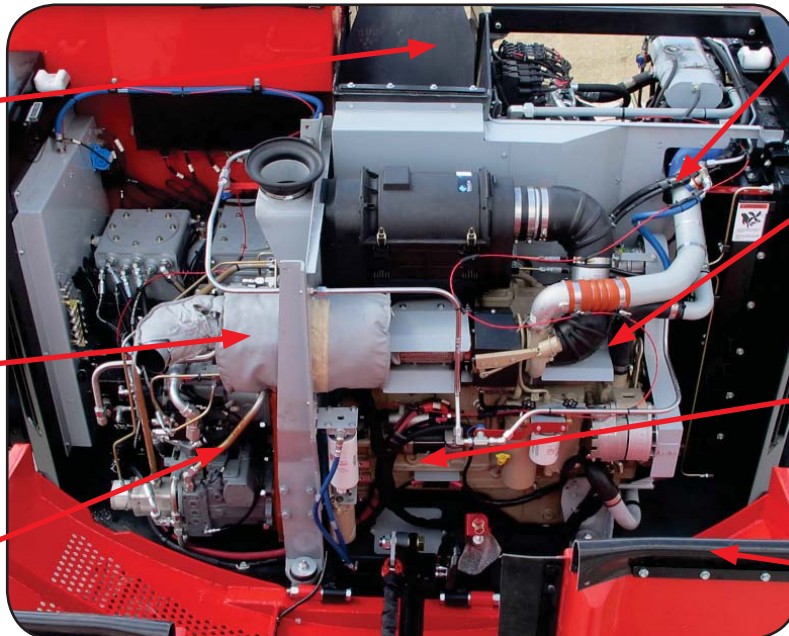

LVS Liquid Fire Suppression Std.

1800 RPM MAX Engine Speed to Increase Fuel Efficiency.

Easy Access to Major Components. (Starter, Alternator, Filters)

Gullwing Rear Door Provides Platform for Service.



Fully Customizable IQAN MD4 HD Touch Screen Control System.

Integrated Cup holder, Cellphone Pocket, and 12v Power Source.

Cabin Skylight and Emergency Escape.

High Output LED Lights

Sliding Side Window For Ventilation.

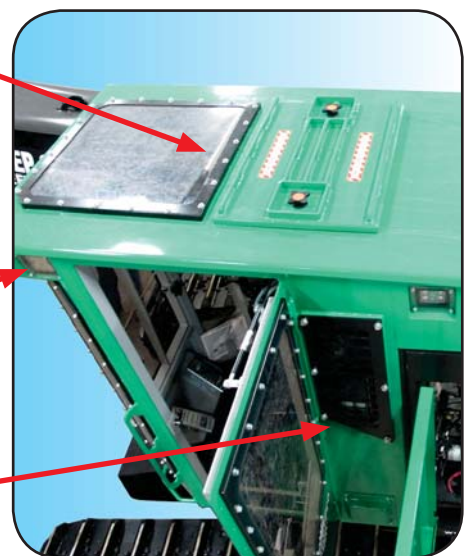

TL - Leveling

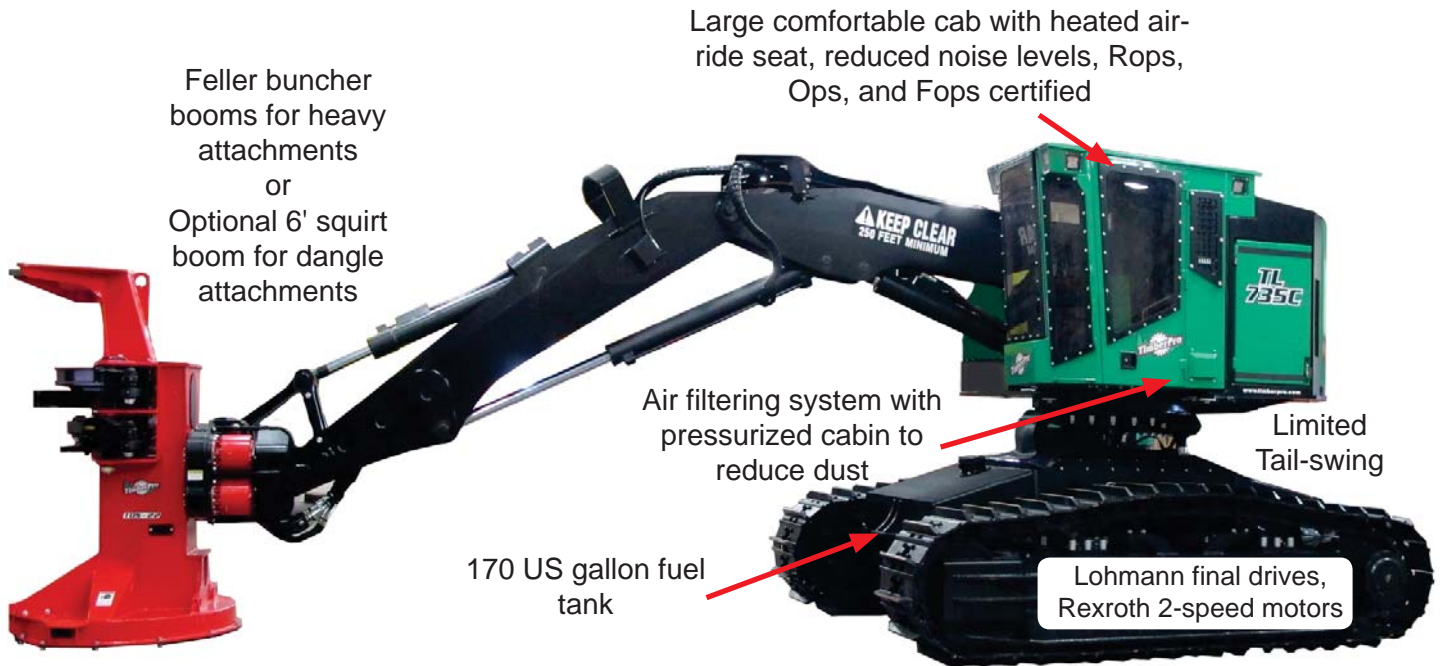

Pictured with TDS22 TimberPro Disc Saw. TBS32 Bar Saw or other attachments available.

735C/745C - Caterpillar D7 size track frames with double flanged rollers

TN - Non Leveling



725C - Caterpillar D6 size track frames with double flanged rollers

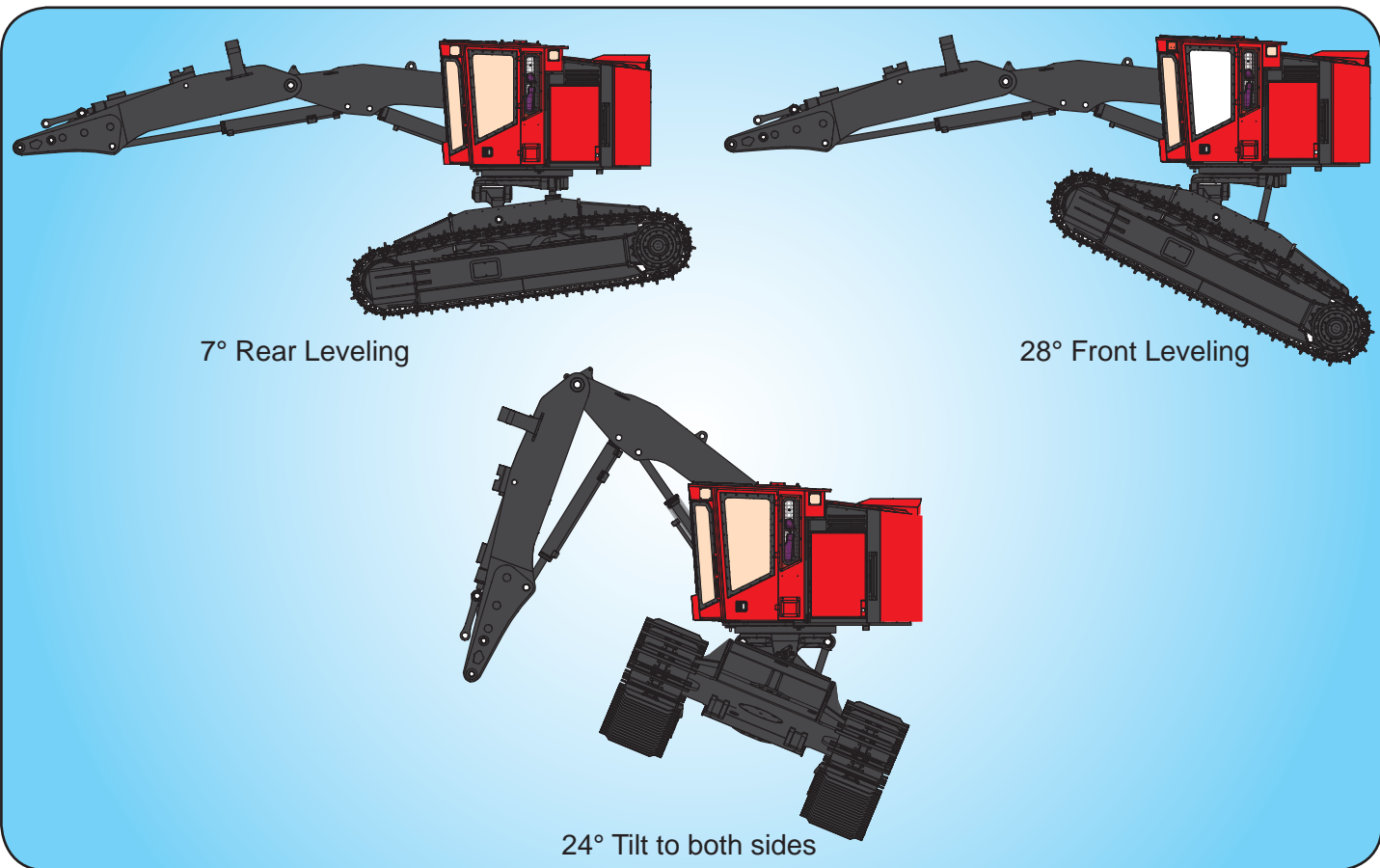

Strongest & simplest 4-way leveling in the industry.



Larger pin and Improved pin retention system.
Providing longer life, better reliability and
easier service.



Smooth under-body, with recessed 1" spring-loaded panel allowing easy access for maintenance.



Built-in auxiliary hydraulic oil storage tank and easy to access lower fuel pump and filter.

Hydraulics	725	735	745
Parker control valves	S	S	S
IQAN MD4 HD control system	S	S	S
Rexroth axial piston pumps	S	S	S
55 gallon hyd oil reservoir	S	S	S
Drive pump gear box cooler	O	O	O
Hyd tank vacuum pump system	S	S	S
Electric hyd oil fill pump	S	S	S
Charge relief heater - Hydraulic oil	S	S	S
Hydrostatic closed loop drive circuits	S	S	S
Continuous rotation swing	S	S	S
Dedicated hydrostatic swing pump	S	S	S
Auto-Leveling Feature	O	O	O
Operator's Cab	725	735	745
Fully certified for ROPS/FOPS/OPS	S	S	S
Three escape routes	S	S	S
½" lexan windows	S	S	S
1½" lexan in front window	O	O	O
Fresh air filtered & Pressurized cab	S	S	S
AM/FM/WB - Bluetooth radio - USB	S	S	S
Standard Seat - Air ride & Heated	S	S	S
Deluxe Seat - Air ride, Heat & Lumbar	O	O	O
Vented side window	S	S	S
High-powered LED lighting	S	S	S
Rear camera system	O	O	O
Your choice of available colors	S	S	S

S = STANDARD ~ O = OPTIONAL ~ NA = NOT AVAILABLE

Safety Features	725	735	745
ANSUL LVS Fire Suppression (WET)	S	S	S
10 lb fire extinguisher	S	S	S
30 lb "water" fire extinguisher	O	O	O
Engine	725	735	745
Volvo TAD873VE Tier4f - 320 HP	O	O	O
Cummins QSC 8.3 - 300 HP	S	S	S
24 volt electrical system w/ 100 amps	S	S	S
Auto reversing - Variable speed fan	S	S	S
Espar Pre-heater with timer	O	O	O
120v AC Pre-heaters	O	O	O
Carbody & Track Options	725	735	745
9'5" (2.86m) TN (Non-Leveling) - Narrow w/24" (600 mm) Shoes	O	O	NA
9'8" (2.86m) TL (Leveling) - Narrow w/24" (600 mm) Shoes	O	O	NA
10' 4" (3.15m) TL or TN - Wide w/24" (600 mm) Shoes	S	S	O
11' 2" (3.4m) TL (Leveling) - Wide w/24" (600 mm) Shoes	O	O	S
24" Single or Double (600 mm)	S	S	S
28" Single or Double (700 mm)	O	O	O
34" Triple (850 mm) 10.4" or 11'2" only	O	O	O
Auto track brakes	S	S	S
Variable track speed control	S	S	S
L & S forestry final drives and motors	S	S	S
Top star rollers	O	O	O
Track mounted counterweights	O	O	O
Fuel tank mounted counterweight	O	O	O

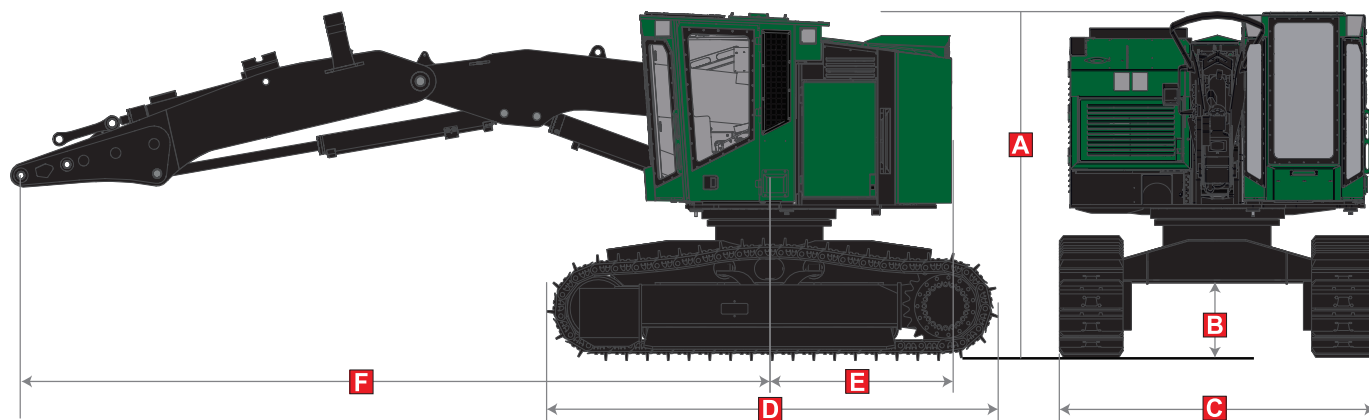

SPECIFICATIONS: TN725C - 49,800 lbs (22,589 kg)*

A	10'9" (3.27 m)
B	27" (68.5 cm)
C	9'5" (2.86 m)

D	15' 4" (4.67 m)
E	5' 9" (1.76 m)
F	23' 9" (7.23 m)

SPECIFICATIONS: TN735C - 54,250 lbs (24,607 kg)*

A	11' 2" (3.76 m)
B	32" (82 cm)
C	10'4" (3.15 m)

D	15' 4" (4.67 m)
E	5' 9" (1.76 m)
F	23' 9" (7.23 m)

*Machine weights are approximate "woods ready" without attachment

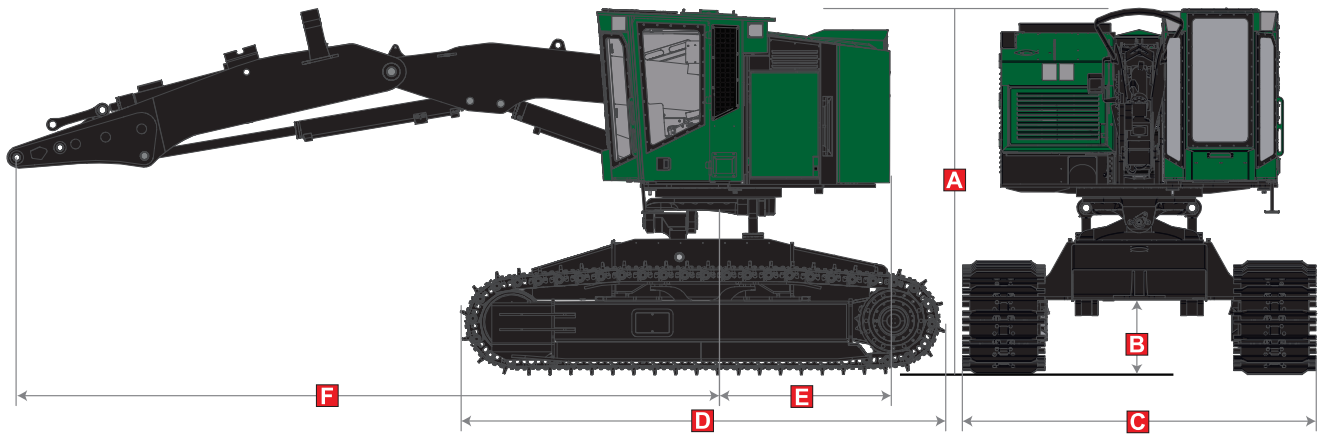

SPECIFICATIONS: TL725C - 55,650 lbs (25,242 kg)*

A	12' (3.66 m)	D	15' 4" (4.67 m)
B	28.5" (72.4 cm)	E	5' 9" (1.76 m)
C	10' 4" (3.15 m)	F	23' 9" (7.23 m)

SPECIFICATIONS: TL735C - 60,080 lbs (27,252 kg)*

A	12' 5" (3.78 m)	D	15' 4" (4.67 m)
B	30.3" (77 cm)	E	5' 9" (1.76 m)
C	10' 4" (3.15 m)	F	23' 9" (7.23 m)

SPECIFICATIONS: TL745C - 65,600 lbs (29,756 kg)*

A	12' 5" (3.78 m)	D	16' 5" (5 m)
B	30.3" (77 cm)	E	5' 9" (1.76 m)
C	11' 2" (3.4 m)	F	23' 9" (7.23 m)

*Machine weights are approximate "woods ready" without attachment

Feller Buncher Lift Capacity:

(7.2 m) 23.5'	9,220 lbs (4,182 kg)
(6.1 m) 20'	12,800 lbs (5,806 kg)
(4.6 m) 15'	17,340 lbs (7,865 kg)
(3.0 m) 10'	25,580 lbs (11,603 kg)

Squirt Boom Lift Capacity:

(9.1 m) 30'	6,300 lbs (2,858kg)
(7.9 m) 25'	8,000 lbs (3,629kg)
(6.1 m) 20'	14,160 lbs (6,423kg)
(4.6 m) 15'	18,000 lbs (8,165kg)
(3.0 m) 10'	24,300 lbs (11,022kg)

Ground Pressure - no attachment

- TN725C - 6.4 PSI w/24" shoes
- TL725C - 6.6 psi w/24" shoes
- TL735C - 7.1 psi w/24" shoes
- TL735C - 4.94 psi w/35" shoes

Tractive Effort - no attachment

- TN725C - 68,629 lbs (1.38:1 power to weight ratio)
- TL725C - 68,629 lbs (1.24:1 power to weight ratio)
- TL735C - 80,066 lbs (1.34:1 power to weight ratio)

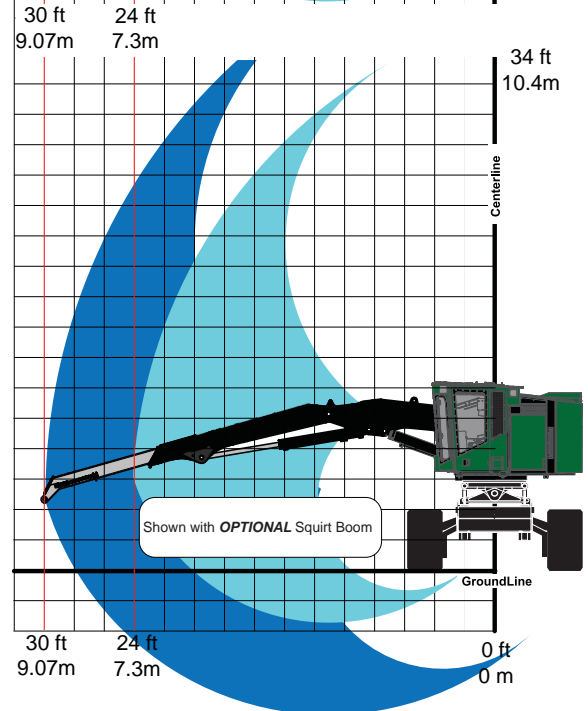
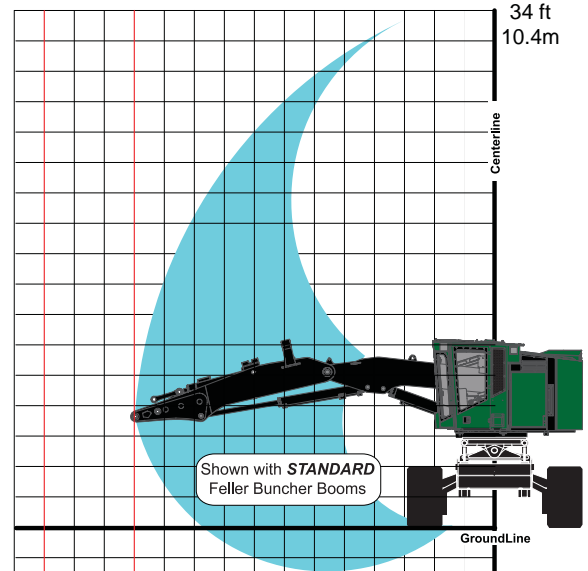

TimberPro Inc reserves the right to change specifications without notice or obligation. Product illustrations may be equipped with non-standard equipment.

TimberPro Inc.
1407 Industrial Dr.
Po Box 415
Shawano WI 54166 USA

Tel: 715-524-7899
Fax: 715-524-7898
E-Mail: info@timberpro.com
www.timberpro.com

