

MICROCOPY RESOLUTION TEST CHART
NATIONAL BUREAU OF STANDARDS-1963-A

DLA



AD-A164 790

AD NO. _____
FUNDING PROJECT NO. 1L161101A91A
TECOM PROJECT (TRMS) NO. 7-CO-I86-AP0-001
REPORT NO. USACSTA-6340



US ARMY
MATERIEL COMMAND

PARTIAL REPORT
ILIR TASK
OF
MECHANICAL GAUGE FOR PEAK CHAMBER PRESSURE
MEASUREMENTS IN LARGE CALIBER GUNS
(CATASTROPHIC FAILURE BACKUP GAUGE)

J. G. FALLER
ENGINEERING DIRECTORATE

U.S. ARMY COMBAT SYSTEMS TEST ACTIVITY
ABERDEEN PROVING GROUND, MD 21005-5059

FEBRUARY 1986

Period Covered:
13 November 1984 to 30 September 1985

Prepared for:
U.S. ARMY TEST AND EVALUATION COMMAND
ABERDEEN PROVING GROUND, MD 21005-5055 DISTRIBUTION UNLIMITED

DTIC
ELECTE
FEB 27 1986
S
D
E

86 2 27 041

DTIC FILE COPY

DISPOSITION INSTRUCTIONS

Destroy this report when no longer needed. Do not return to the originator.

DISCLAIMER STATEMENT

The views, opinions, and/or findings in this report are those of the author(s) and should not be construed as an official Department of th Army position, unless so designated by other official documentation.

Unclassified

SECURITY CLASSIFICATION OF THIS PAGE (When Data Entered)

REPORT DOCUMENTATION PAGE		READ INSTRUCTIONS BEFORE COMPLETING FORM
1. REPORT NUMBER TECOM Project 7-CO-186-AP0-001	2. GOVT ACCESSION NO. ADA 164790	3. RECIPIENT'S CATALOG NUMBER
4. TITLE (and Subtitle) ILIR TASK OF MECHANICAL GAUGE FOR PEAK CHAMBER PRESSURE MEASUREMENTS IN LARGE CALIBER GUNS (CATASTROPHIC FAILURE BACKUP GAUGE)	5. TYPE OF REPORT & PERIOD COVERED Partial, 13 November 1984 to 30 September 1985	
	6. PERFORMING ORG. REPORT NUMBER USACSTA-6340	
7. AUTHOR(s) J. G. Faller	8. CONTRACT OR GRANT NUMBER(s) Not available	
9. PERFORMING ORGANIZATION NAME AND ADDRESS U.S. Army Combat Systems Test Activity ATTN: STECS-EN-P Aberdeen Proving Ground, MD 21005-5059	10. PROGRAM ELEMENT, PROJECT, TASK AREA & WORK UNIT NUMBER Not available	
11. CONTROLLING OFFICE NAME AND ADDRESS Commander, TECOM ATTN: AMSTE-TC-M Aberdeen Proving Ground, MD 21005-5055	12. REPORT DATE February 1986	
	13. NUMBER OF PAGES	
14. MONITORING AGENCY NAME & ADDRESS (if different from Controlling Office) None	15. SECURITY CLASS. (of this report) Unclassified	
	15a. DECLASSIFICATION/DOWNGRADING SCHEDULE None	
16. DISTRIBUTION STATEMENT (of this Report) Distribution unlimited.		
17. DISTRIBUTION STATEMENT (of the abstract entered in Block 20, if different from Report) None		
18. SUPPLEMENTARY NOTES None		
19. KEY WORDS (Continue on reverse side if necessary and identify by block number) Pressure gauge Chamber pressure measurements Catastrophic failure backup gauge Mechanical pressure gauge		
20. ABSTRACT (Continue on reverse side if necessary and identify by block number) A new pressure gauge based on the shearing of circular plugs in metals is being investigated for use in large caliber guns when chamber pressures may exceed 120 kpsi. The proposed shear gauge can in principle be made to measure peak chamber pressures up to and greater than 300 kpsi. A prototype model of the gauge has been designed and fabricated, but not yet tested. The design of the shear gauge involves the shearing of a uniformly loaded circular plate at its circumferential support. Stresses due to bending and shear were analyzed to choose the proper hole radius-to-thickness ratio that ensures a shearing		

DD FORM 1 JAN 73 1473 EDITION OF 1 NOV 65 IS OBSOLETE

Unclassified

SECURITY CLASSIFICATION OF THIS PAGE (When Data Entered)



DEPARTMENT OF THE ARMY
U. S. ARMY COMBAT SYSTEMS TEST ACTIVITY Mr. Faller/mr/298-4461
ABERDEEN PROVING GROUND, MARYLAND 21885-8888

REPLY TO
ATTENTION OF

STECS-EN-P

10 February 1986

SUBJECT: Partial Report on ILIR Task of Mechanical Gauge for Peak Chamber Pressure Measurements in Large Caliber Guns (Catastrophic Failure Backup Gauge), TECOM Project No. 7-CO-186-APO-001, Report No. USACSTA-6340

Commander
U.S. Army Test and Evaluation Command
ATTN: AMSTE-TC-M

1. REFERENCES

- a. Timoshenko, S., and Woinowsky-Krieger, S., Theory of Plates and Shells, McGraw-Hill, New York, 1959.
- b. Aluminum Standards and Data, the Aluminum Association, Inc., Washington, 1982.
- c. Structural Alloys Handbook, Volume 1, Mechanical Properties Data Center, Belfour Stulen, Inc., Traverse City, MI, 1977.

2. BACKGROUND

a. In the recent past a number of failure incidents involving large caliber guns have taken place at Aberdeen Proving Ground. In these cases, no accurate data of the pressures reached in the guns before tube failure were obtained, in spite of the presence of both mechanical crusher gauges and piezoelectric transducers on the guns. It was apparent in these failures that the gauges used had neither the range to measure the high chamber pressures nor the capability to survive the shock and impact damage associated with a catastrophic event. The upper range of the crusher gauges used was 100 kpsi and that of the piezo transducers, 108 kpsi. With the crusher gauge one relies on fine dimensional measurements on a copper sphere for determining pressure; any slight damage to this sphere destroys the usefulness of the gauge. The piezo transducer, on the other hand, is even more easily incapacitated by the destruction of wires and terminal connections. In addition, its piezo crystal may respond unpredictably if the hole into which it fits in the gun tube wall becomes deformed.

A gauge has been designed to address the need for measurement of chamber pressures above the range of the crusher gauge, although pressures above 120 kpsi are presently outside the normal functioning of guns. The report presents the theory behind the shear pressure gauge and the design of the prototype model awaiting experimental testing.

b. The investigation began on 5 November 1984 and ended on 30 September 1985.

3. TEST OBJECTIVE

The objective was to develop a mechanical pressure gauge with the capacity to measure pressure above 120 kpsi.

4. SUMMARY OF PROCEDURES

a. The theory of the gauge was developed.

b. A prototype model of the gauge was designed and fabricated along with a test fixture for testing the gauge in a pressure generator. Detailed part drawings were prepared using the computer aided design system (CAD) mounted on the IBM 4341 computer.

5. SUMMARY OF RESULTS

a. Theory of the shear pressure gauge. The design of the pressure gauge involves the shearing of a uniformly loaded circular plate at its circumferential support. To ensure shearing and not a bending failure, which would be uninterpretable, it was necessary to choose the proper hole diameter-to-plate thickness ratio. This was done by solving simultaneously the equations for bending and shear failure (ref 1a). Bending failure will occur at the pressure predicted by the following equation:

$$P_b = 4\sigma_y (t/r)^{2/3}$$

where:

P_b = pressure to initiate tensile yield at the support
 σ_y = tensile yield strength of the plate material
 t = thickness of the plate
 r = radius of the hole under the plate.

The pressure which will cause shearing is given by the following equation:

$$P_s = 2\tau_u (t/r)$$

where:

P_s = pressure to cause shear failure at the support
 τ_u = ultimate shear strength of the plate material
 t = thickness of the plate
 r = radius of the hole under the plate.

5 (Cont'd)

The above equations can be developed simultaneously by setting P_b equal to P_s , resulting in the derivation of the critical hole radius to thickness ratio $(r/t)_{cr}$, for a shear failure. The relationship is given by $(r/t)_{cr} = 2\sigma_y/3\tau_u$ and the corresponding critical pressure, P_{cr} , by $P_{cr} = 3\tau_u^2/\sigma_y$.

The preceding equations are summarized and illustrated in Figures 1 and 2 of Enclosure 1. In Figure 2 (encl 1) it is seen that P_{cr} is the pressure which will cause a simultaneous failure in shear and initiation of tensile yield at the support. Above P_{cr} shear failure is assured and below it only bending failure is possible.

The mechanical properties of a large number of aluminum and steel materials were examined to find the pressure range in which they could be used as circular plate material in the pressure gauge (ref 1b and 1c). A partial list of these properties is shown in Enclosure 2. The properties indicate that the shear gauge has a range from 20 kpsi to 350 kpsi. Critical radius-to-plate-thickness ratios for the materials listed are between 0.36 and 1.15.

b. Prototype model. A prototype model of the shear pressure gauge was designed and manufactured. The assembly drawing of the gauge is shown in Figure 3 (encl 1), and the detailed drawings for the various parts are shown in Figures 4 through 7 of Enclosure 1. The gauge is also designed to be accommodated in a cartridge as shown in Figure 8 (encl 1).

The basecap, the housing, and the top cap were all designed with a hexagonal geometry for easy assembly. The gauge has outside dimensions of 1.5 by 1.4 inch and can accommodate a 0.1 inch thick wafer plate. Copper covers applied at both ends are intended to prevent damage to the gun tube interior.

Initially the gauge was made with two holes for ease of fabrication, although in principle the gauge can be made with several holes as long as it is not structurally weakened. The two holes of the prototype are 0.100 and 0.200 inch in diameter. The components for the shear gauge with the exception of the wafer plate are made of AISI 4140 steel hardened to Rockwell C 36-40. All mating surfaces were machined to a fine finish to assure a good pressure seal without which the gauge as designed cannot be expected to function accurately.

The materials that will initially be used for the wafer plate will be those highlighted in Enclosure 2 by an arrow; they include 1060-H16, 3004-H32, and 5052-H38 aluminum alloys. With the first of these materials the large hole should result in a failure of the wafer plate at 20 kpsi and the smaller hole, at 40 kpsi. With the last of these materials the corresponding pressures are 47 and 94 kpsi.

c. Planned testing. The shear gauge will be tested statically and dynamically in hydraulic test machines having respective capabilities of 80 and 100 kpsi. If the gauge performs satisfactorily at these pressures, it will be tested dynamically at pressures up to 150 kpsi using a closed bomb apparatus. A test fixture for the gauge which is suitable for the static pressure generator is shown in Figures 9 and 10 (encl 1).

6. ANALYSIS

a. The principal features of the shear pressure gauge are a small size, the lack of temperature and pressure limitations, the absence of any moving parts, and the low manufacturing cost, assuming that all components with the exception of the wafer plate are reusable. The disadvantage of the gauge is the discrete nature of the measurement, which does not give a precise reading but an upper and lower limit within a given tolerance.

b. The theoretical analysis shows that the concept of the gauge is a sound one. It remains to be determined from testing, if the performance of the gauge as designed can equal the expectations raised by the theoretical development.

c. Looking beyond the successful testing of the prototype, it will be necessary to modify the current design to obtain a gauge having greater pressure resolution through the introduction of additional holes and smaller overall dimensions. To achieve such a goal finite element analysis of alternative designs will be required.

7. CONCLUSION

It is concluded that the shear failure of a circular plate over a hole represents a workable idea for a pressure gauge which can be used in the chambers of large caliber guns as a catastrophic backup gauge.

8. RECOMMENDATION

It is recommended that the work on the shear pressure gauge be continued.

FOR THE COMMANDER:



DONALD RESCH
Technical Director

- 3 Encl
1. Figures
2. Pertinent Shear Gauge Data
3. Distribution List

FIGURES

FAILURE STRESS ANALYSIS

1. STRESS DUE TO BENDING - σ_y

$$M = \frac{p r^2}{8} \quad \text{AT SUPPORT}$$

$$\sigma_{\max} = \frac{MC}{I} = \frac{M(t/2)}{\frac{1}{12}(t)^3} = \frac{6M}{t^2}$$

$$\sigma_{\max} = \frac{3}{4} \frac{p r^2}{t^2}$$

FOR $\sigma_{\max} = \sigma_y$, PRESSURE IS p_b

$$p_b = \frac{4 \sigma_y t^2}{3 r^2} \quad (1)$$

2. STRESS DUE TO SHEAR - τ_u

$$p (\pi r^2) = \tau (2 \pi r t)$$

$$p = \frac{2 \tau t}{r}$$

FOR $\tau = \tau_u$, PRESSURE IS p_s

$$p_s = \frac{2 \tau_u t}{r} \quad (2)$$

3. SIMULTANEOUS DEVELOPMENT OF σ_y AND τ_u AT SUPPORT

$$p_b = p_s \quad \therefore \quad \left(\frac{r}{t} \right)_{cr} = \frac{2 \sigma_y}{3 \tau_u} \quad \& \quad \tau_{cr} = \frac{3 \tau_u^2}{\sigma_y}$$

$$\left(\frac{r}{t} \right)_{cr} < 1 \quad \text{IN GENERAL}$$

→ FOR $\frac{r}{t} < \left(\frac{r}{t} \right)_{cr}$: ULTIMATE SHEAR τ_u DEVELOPS BEFORE σ_y

→ FOR $\frac{r}{t} > \left(\frac{r}{t} \right)_{cr}$: σ_y DUE TO BENDING DEVELOPS PRIOR TO τ_u

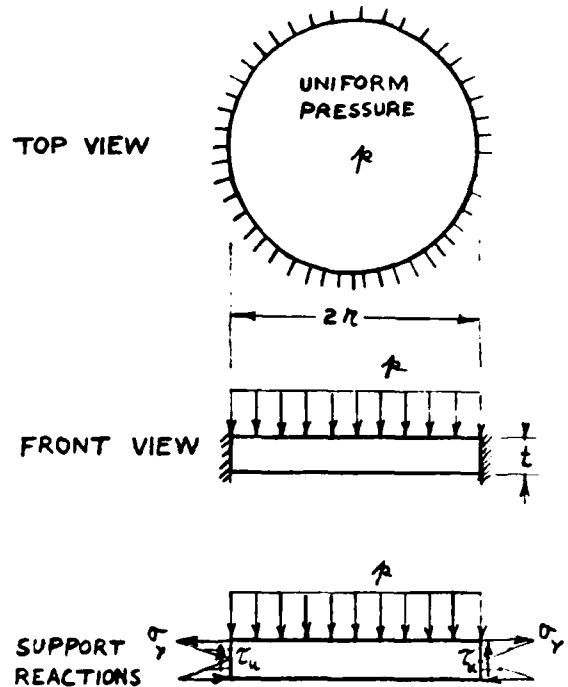

UNIFORMLY LOADED PLATE SHEAR

Figure 1. Development of equations for uniformly loaded plate in shear.

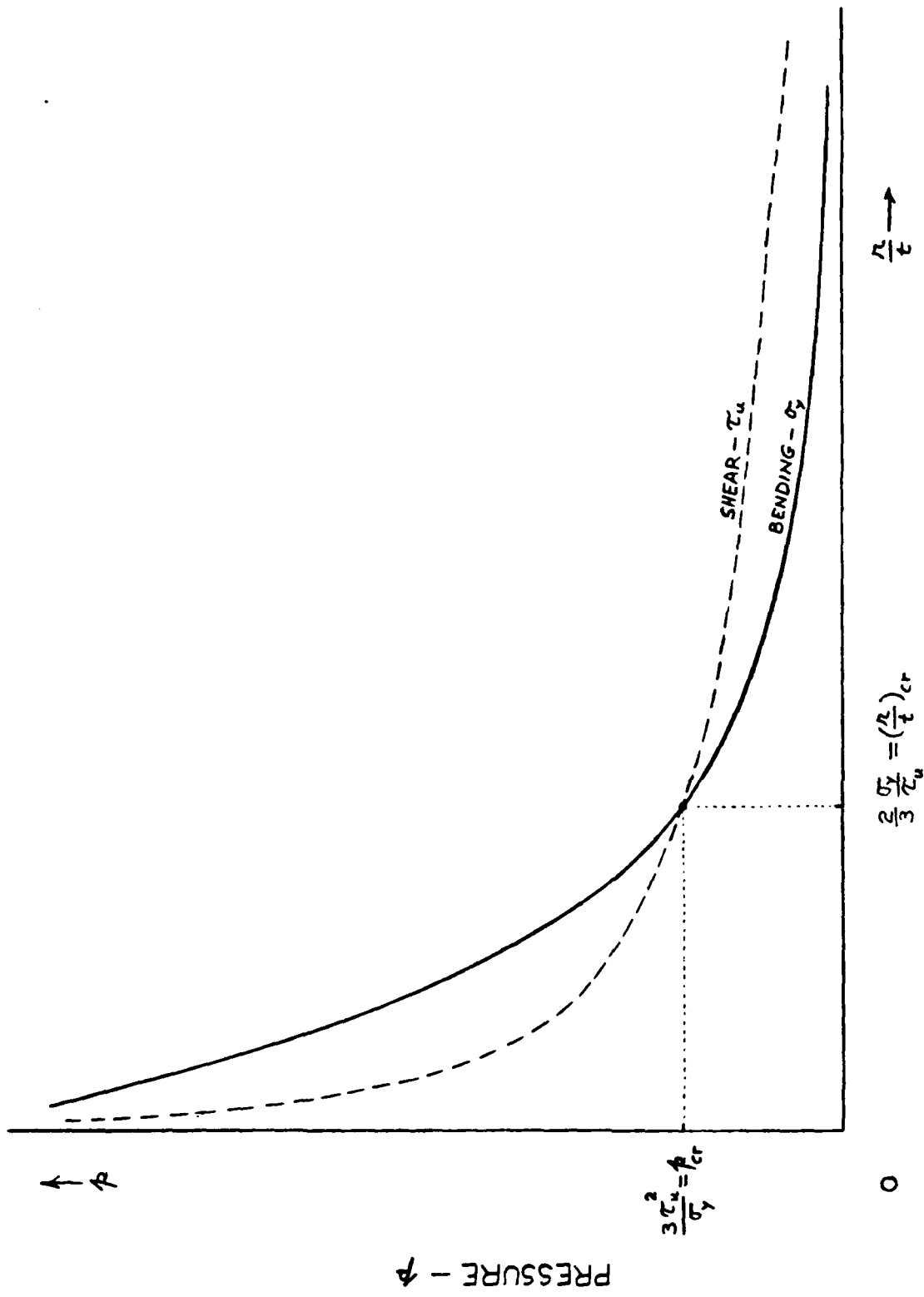

PRESSURE VS. RADIUS OVER THICKNESS RATIO

Figure 2. Curve illustrating the relationship between pressure and the radius-over-thickness ratio for the uniformly loaded plate in shear.

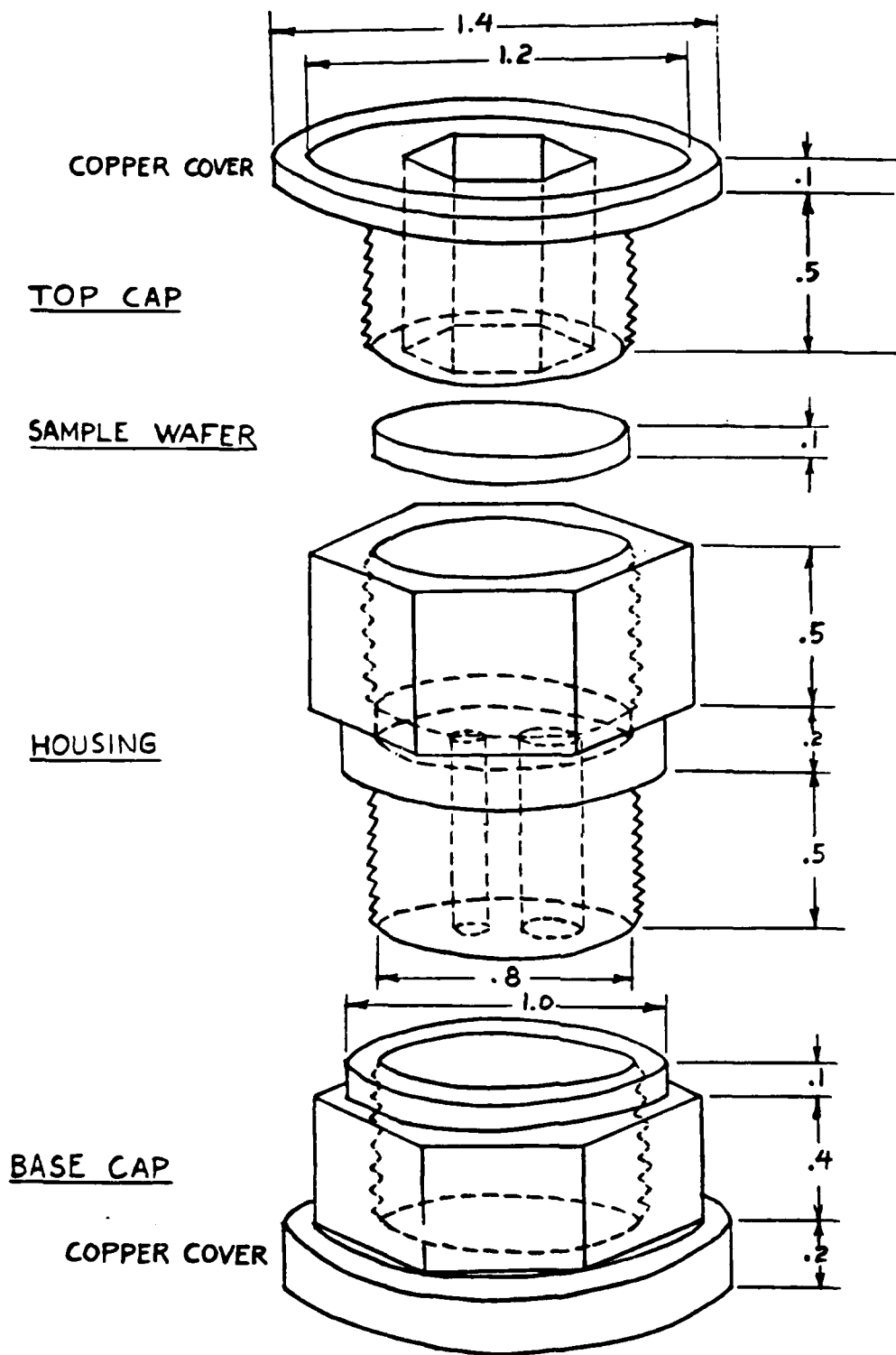

SHEAR GAGE (ASSEMBLY)

Figure 3. Assembly drawing of the prototype shear pressure gauge.

TOP CAP

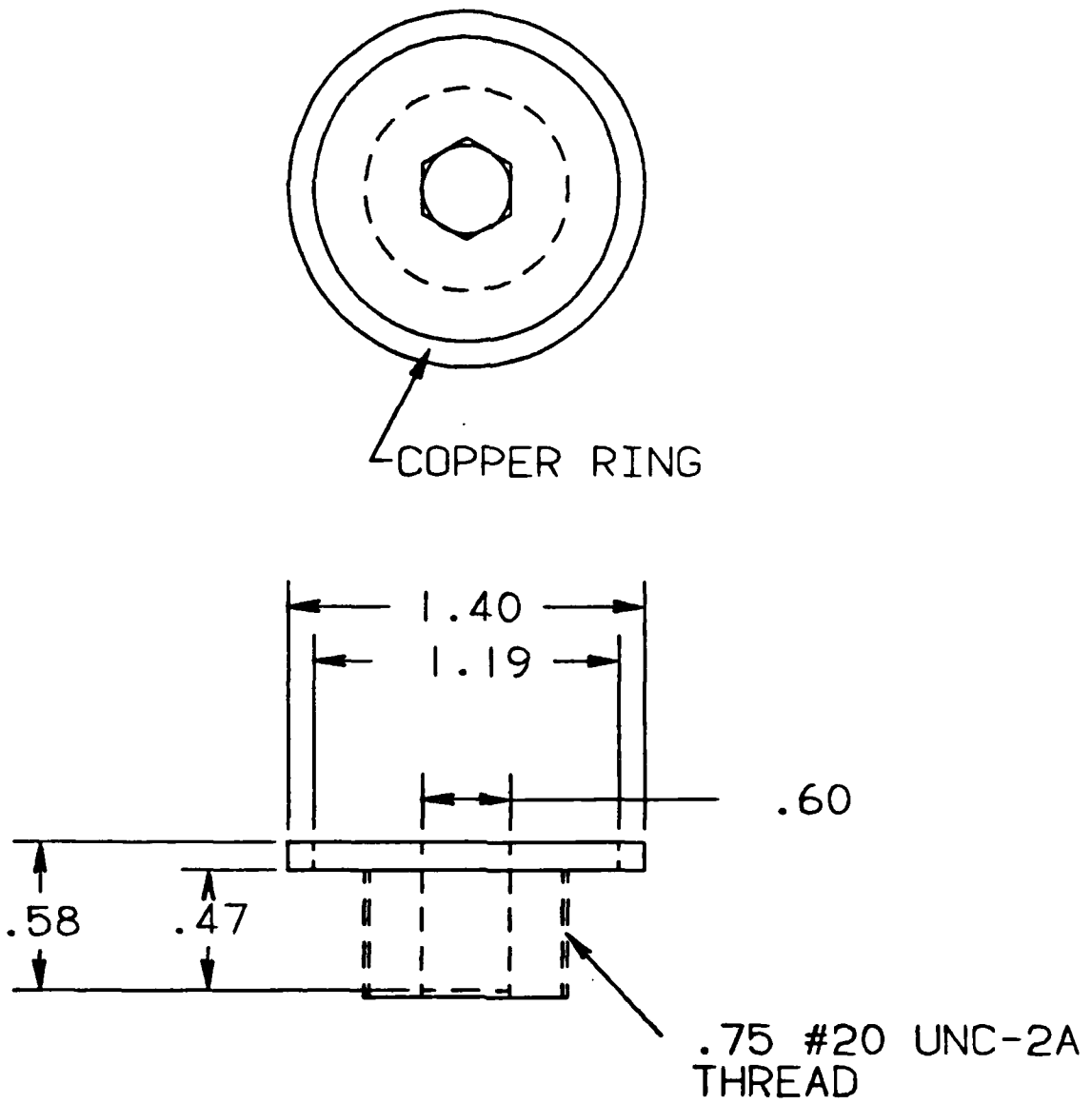

Figure 4. Top cap of the prototype shear pressure gauge.

WAFER

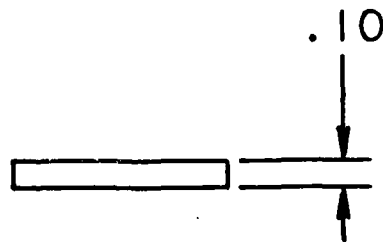
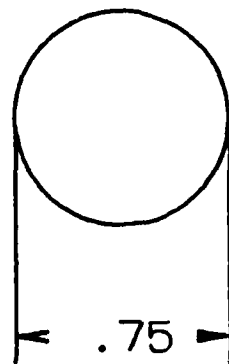

Figure 5. Wafer plate of the prototype shear pressure gauge.

HOUSING

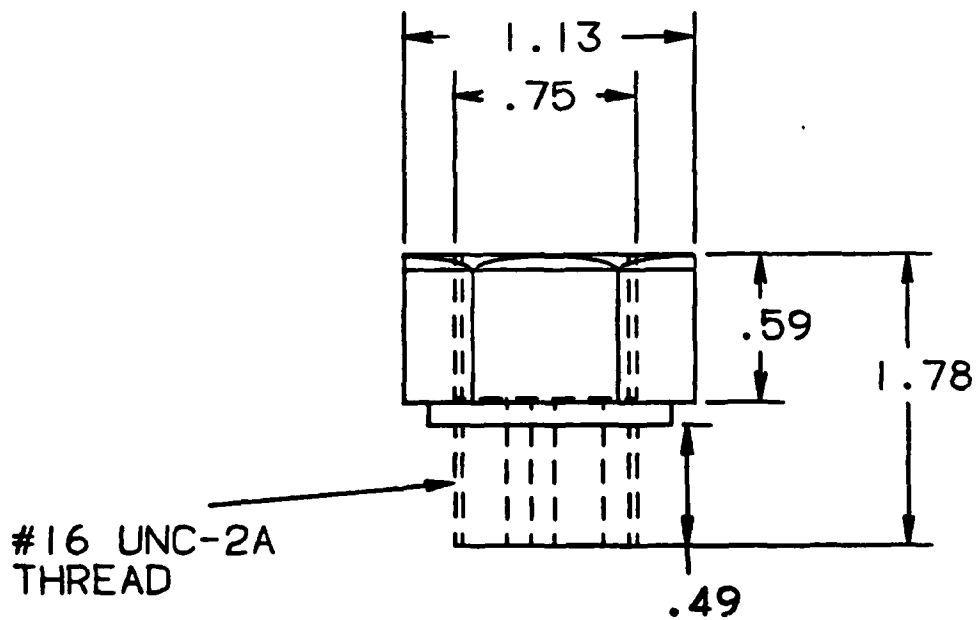
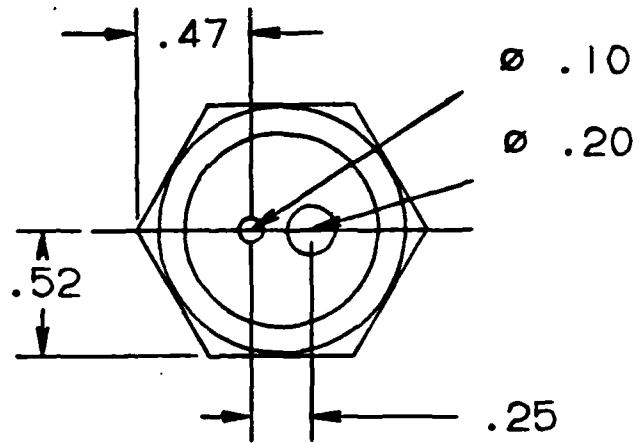

Figure 6. Housing of the prototype shear pressure gauge.

BASE CAP

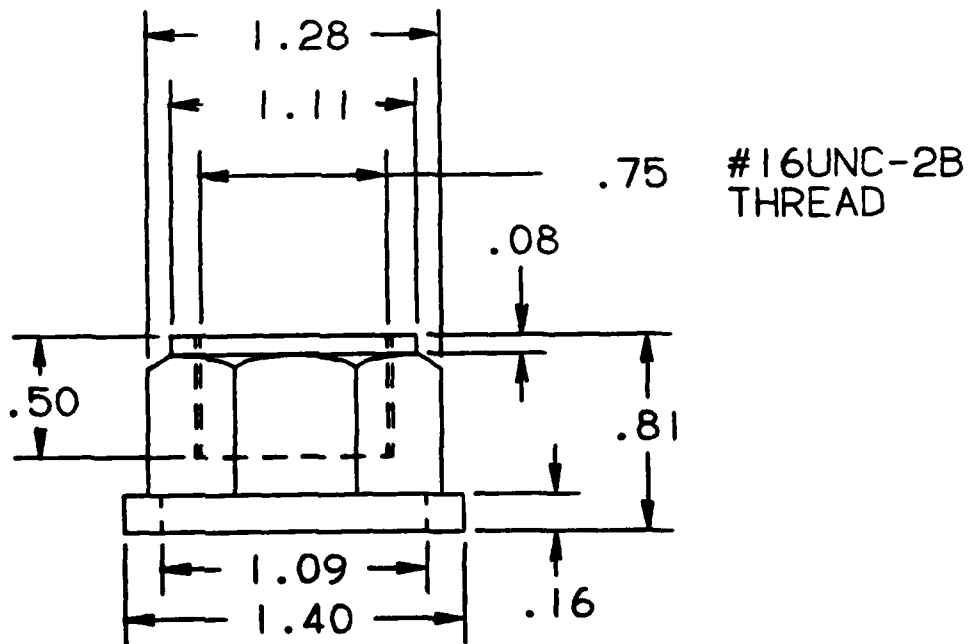
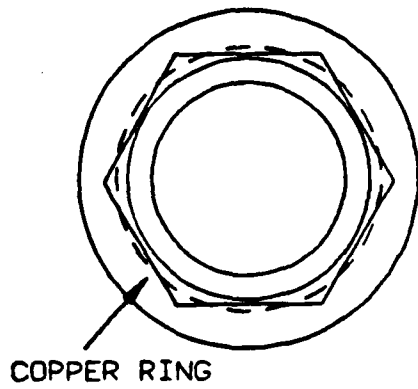

Figure 7. Base cap of the prototype shear pressure gauge.

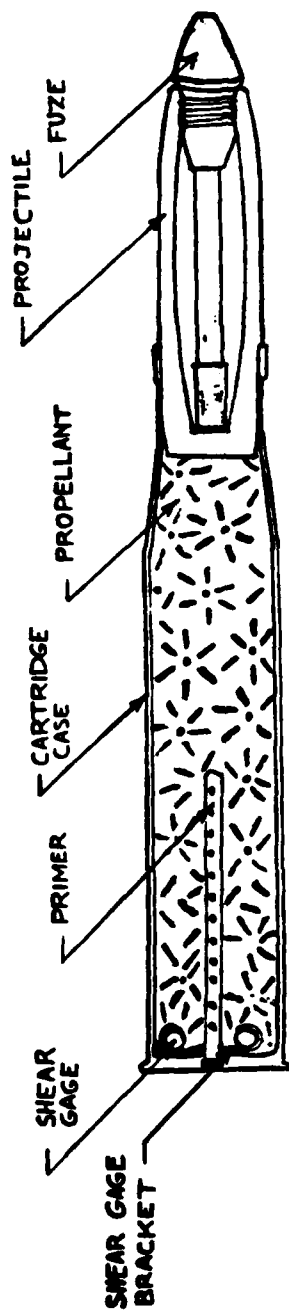

FIG.3 - SHEAR GAGE INSIDE A CARTRIDGE

Figure 8. Location of the shear pressure gauge inside a cartridge case.

TEST FIXTURE
PART A

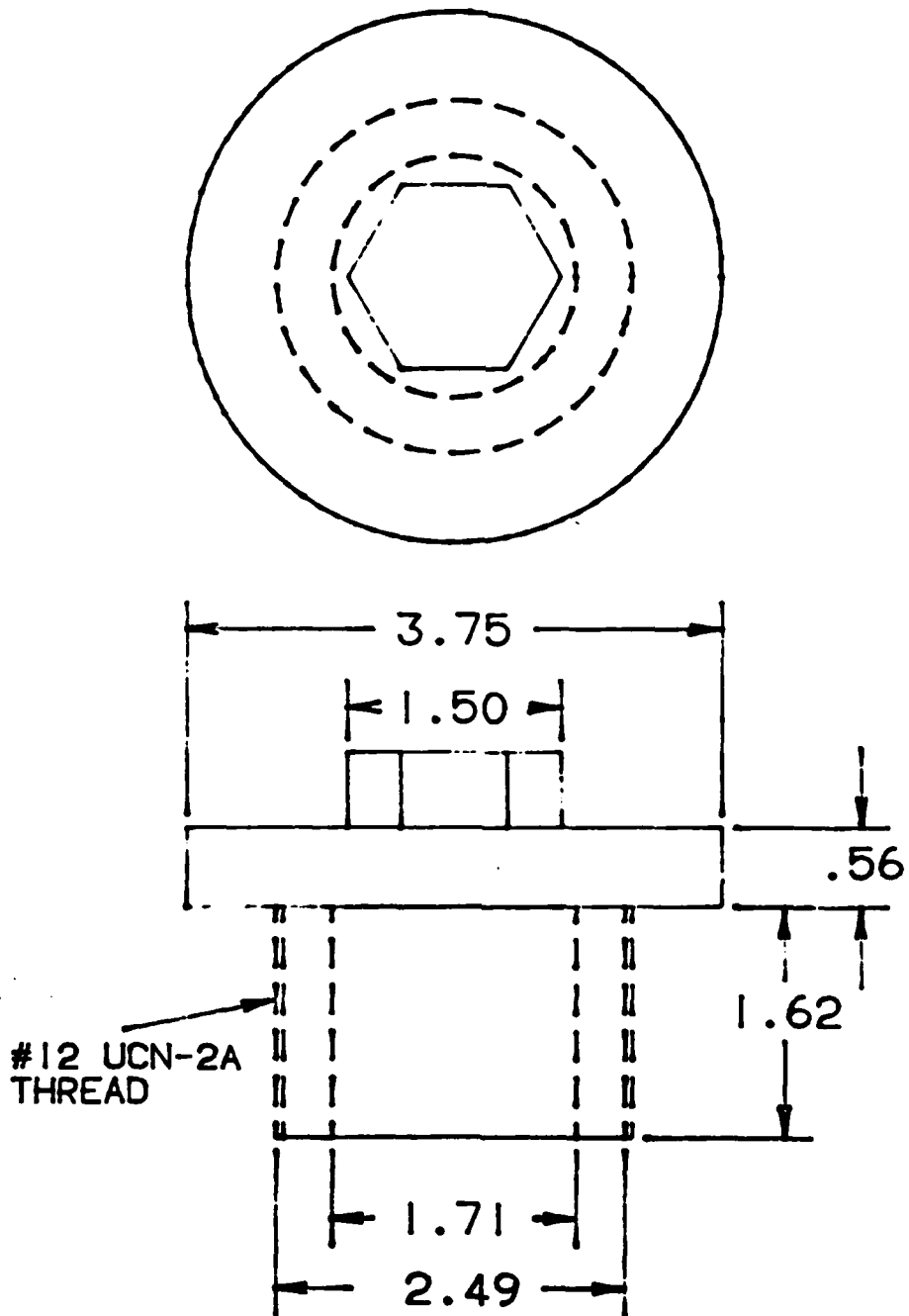

Figure 9. Test Fixture, Part A.

TEST FIXTURE
PART B

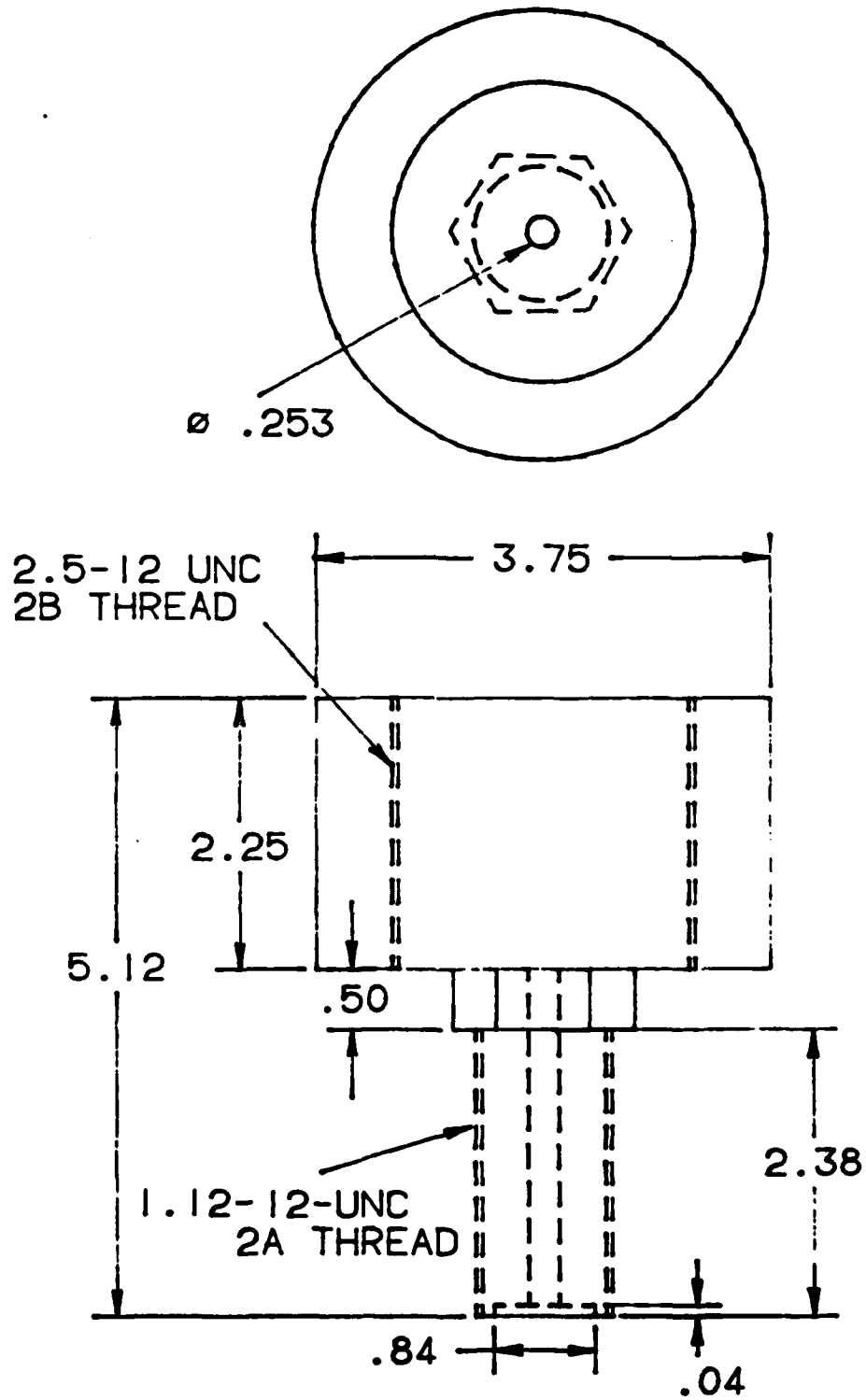

Figure 10. Test Fixture, Part B.

PERTINENT SHEAR GAUGE DATA

PERTINENT SHEAR GAUGE DATA FOR SOME STEEL AND ALUMINUM METALS

Metal	Tensile Yield Stress, σ_y (kpsi)	Ultimate Shear Stress, τ_u (kpsi)	Chamber Pressure P_{cr} (kpsi)	Radius to Thickness Ratio $(r/t)_{cr}$
Steel 1020 Norm	50	54.2	176.26	0.615
" 1030 Annealed	50	51.4	158.52	0.649
" 1095 "	55	63	216.49	0.582
" 4140 OQ+1200F	95	55	95.53	1.152
" 4140 OQ+1000F	143	100	209.79	0.953
" 8630 Norm	62	85	349.60	0.486
→ Aluminum 1060-H16	15	10	20.00	1.000
" 1060-H18	18	11	20.17	1.091
" 2011-T3	43	32	71.44	0.896
" 2014-0	14	18	69.43	0.519
→ " 3004-H32	25	17	34.68	0.980
" 5005-0	6	11	60.50	0.364
" 5005-H12	19	14	30.95	0.905
→ " 5052-H38	37	24	46.70	1.028
" 6262-T9	55	35	66.82	1.048
" 6463-T6	31	22	46.84	0.939

DISTRIBUTION LIST

TECOM Project No. 7-CO-186-APO-001

<u>Addressee</u>	<u>No. of Copies</u>
Commander U.S. Army Test and Evaluation Command ATTN: AMSTE-TC-M AMSTE-TE-F Aberdeen Proving Ground, MD 21005-5055	3 1
Commander U.S. Army Armament Research and Development Command Dover, NJ 07801	1
Commander Watervliet Arsenal ATTN: SMCWV-RDS-AE, Mr. H. Powis SMCWV-RDR-BMM, Dr. T. Davison Watervliet, NY 12189-5000	1 1
Commander U.S. Army Materials Technology Laboratory ATTN: AMXMR-MN, Mr. H. Hatch Watertown, MA 02172-0001	1
Commander U.S. Army Yuma Proving Ground Yuma, AZ 85304-9102	1
Commander U.S. Army Jefferson Proving Ground Madison, IN 47251-5100	1
Commander U.S. Army White Sands Missile Range ATTN: STEWS-TE-P New Mexico 88002-5076	1
Director U.S. Army Ballistic Research Laboratory ATTN: SLCBR-BLT, Dr. F. I. Grace SLCBB-DD-T (STINFO) Aberdeen Proving Ground, MD 21005-5066	2 2

DISTRIBUTION LIST

TECOM Project No. 7-CO-186-APO-001

<u>Addressee</u>	<u>No. of Copies</u>
Commander U.S. Army Test and Evaluation Command ATTN: AMSTE-TC-M AMSTE-TE-F Aberdeen Proving Ground, MD 21005-5055	3 1
Commander U.S. Army Armament Research and Development Command Dover, NJ 07801	1
Commander Watervliet Arsenal ATTN: SMCWV-RDS-AE, Mr. H. Powis SMCWV-RDR-BMM, Dr. T. Davison Watervliet, NY 12189-5000	1 1
Commander U.S. Army Materials Technology Laboratory ATTN: AMXMR-MN, Mr. H. Hatch Watertown, MA 02172-0001	1
Commander U.S. Army Yuma Proving Ground Yuma, AZ 85304-9102	1
Commander U.S. Army Jefferson Proving Ground Madison, IN 47251-5100	1
Commander U.S. Army White Sands Missile Range ATTN: STEWS-TE-P New Mexico 88002-5076	1
Director U.S. Army Ballistic Research Laboratory ATTN: SLCBR-BLT, Dr. F. I. Grace SLCBB-DD-T (STINFO) Aberdeen Proving Ground, MD 21005-5066	2 2

END

FILMED

4-88

DTIC