

# CHUCK JAW CATALOG

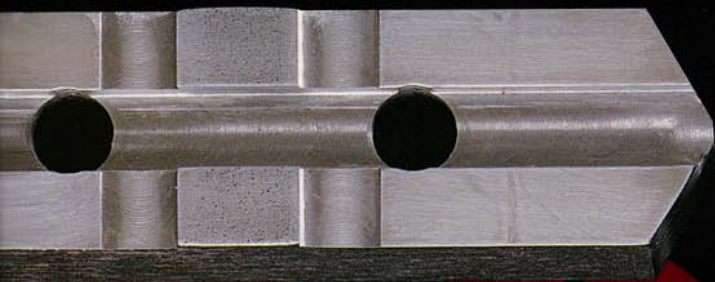

**ROVI**®

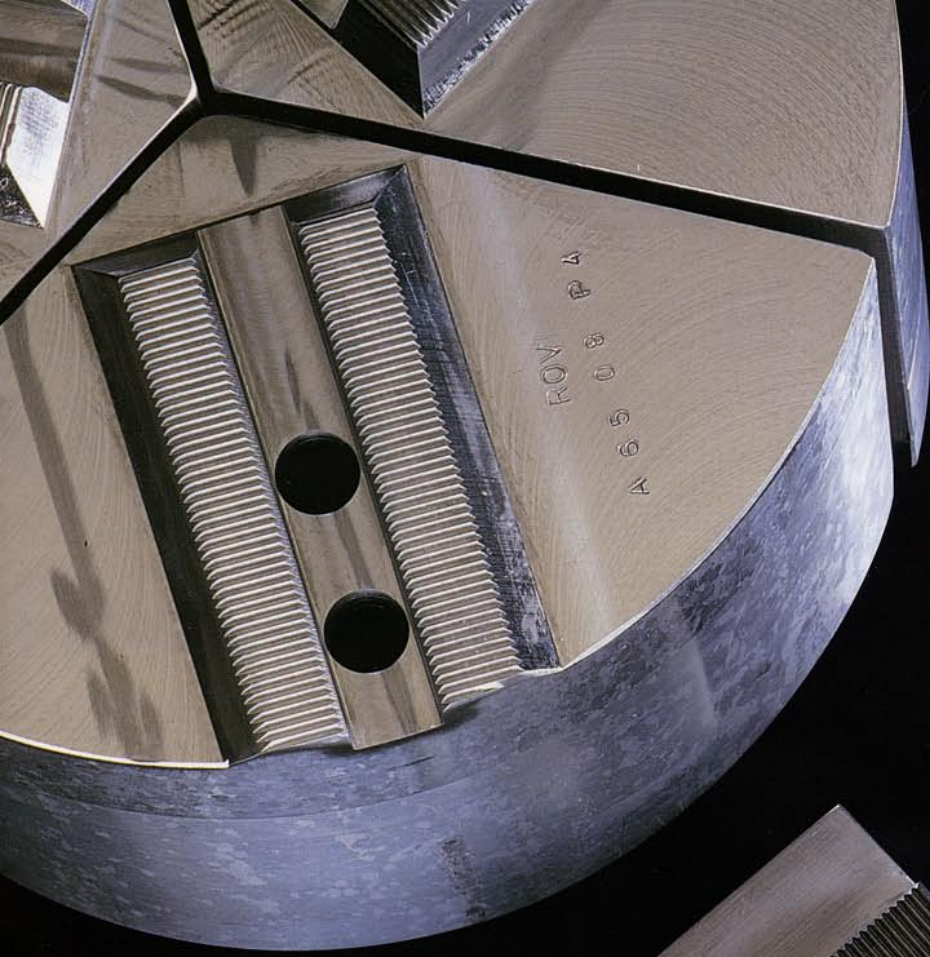

## The Jaws You Need, When You Need Them

For your convenience, ROVI manufactures and stocks Chuck Jaws in Metric and English Serrated, as well as American Standard Tongue & Groove styles. Most jaws are available for chuck diameters from 6" to 15"... In addition, they are versatile, they are available in both 1018 Steel and 6061-T6 Aluminum. Our inventory is expanding continuously to keep pace with your needs. If you don't see what you are looking for in your catalog, please ask!

## Quality You Can Depend On

You can depend on all ROVI chuck jaws to be manufactured to the highest standards to ensure durability, accuracy, ease of use and to maximize the productivity on your job. Our **Full Circle Jaws**, for example, are innovatively engineered and then produced from **solid, not cast**, 6061-T6 Aluminum. This assures you of quality tooling and at an affordable price tool. With every set of ROVI Chuck Jaws you'll find the same craftsmanship and attention to detail that has for over thirty years made the ROVI line of **Internal Expanding Collets** famous as one of the **most trusted brands** of workholding products in the industry.

## The Guarantee Is In The Name

Like every product which bears the ROVI name, our chuck jaws come with an unconditional guarantee of quality and satisfaction. **"If, for any reason, you are not satisfied, simply return all unused product for a full, prompt and courteous refund."**

## At Your Service

You'll like working with us. Whether you need to order or gain technical advice, you'll **always** receive helpful, friendly and knowledgeable service. **That is, always has been, and always will be our commitment to you, our customer...** and just like our service, our quality and prices will give you something to smile about, too. That's the way we want it. We guarantee, you'll like it too!

## Take Stock In ROVI

Our warehouse is stocked around your workholding needs. You'll order with confidence, knowing the chuck jaws you need will be there when you need them. Dependable delivery will give you one less thing to worry about. To meet your production scheduling requirements, all in-stock products are available for same day shipment, when orders are received before 3PM.

©1997 Rovi Products Incorporated, Simi Valley, California. All Rights Reserved.  
In our effort to meet customers changing needs and continuously improve our products, we reserve the right to make changes in specifications without notice.

## Chuck Jaw Catalog Table of Contents

	Page
<b>Standard Metric Serrated Soft Jaws, Steel and Aluminum – 1.5mm x 60° Serrations</b> For: Howa, Kitagawa, MMK, Matsumoto and others.....	1
<b>Metric Serrated Full Circle Aluminum Jaws – 1.5mm x 60° Serrations</b> For: Howa, Kitagawa, MMK, Matsumoto and others.....	2
<b>Standard Metric Serrated Soft Jaws, Steel and Aluminum – 3mm x 60° Serrations</b> For: Howa, Kitagawa, MMK, Matsumoto and others.....	3
<b>Metric Serrated Full Circle Aluminum Jaws – 3mm x 60° Serrations</b> For: Howa, Kitagawa, MMK, Matsumoto and others.....	3
<b>Standard Metric Serrated Soft Jaws, Steel and Aluminum – 1.5mm x 60° Serrations (15" Chuck has a 3mm Serrations)</b> For: Hitachi Seiki Chucks .....	4
<b>Metric Serrated Full Circle Aluminum – 1.5mm x 60° Serrations (15" Chuck has a 3mm Serrations)</b> For: Hitachi Seiki Chucks .....	4
<b>Standard English Serrated Soft Jaws, Steel and Aluminum – .065 x 90° Serrations</b> For: Gamet, Power Hold Rohm and others.....	5
<b>Standard English Serrated Soft Jaws, Steel and Aluminum – .065 x 90° Serrations</b> For: SMW and Autoblock .....	5
<b>English Serrated Full Circle Aluminum Jaws – .065 x 90° Serrations</b> For: Gamet, Power Hold Rohm and others.....	6
<b>English Serrated Full Circle Aluminum Jaws – .065 x 90° Serrations</b> For: SMW and Autoblock .....	6
<b>American Standard Medium Duty Tongue &amp; Groove Jaws – Steel &amp; Aluminum.....</b>	7
<b>American Standard Medium Duty Tongue &amp; Groove – Full Circle Jaws – Steel &amp; Aluminum .....</b>	8
<b>American Standard Heavy Duty Tongue &amp; Groove Jaws – Steel &amp; Aluminum .....</b>	9
<b>American Standard Heavy Duty Tongue &amp; Groove – Full Circle Jaws – Steel &amp; Aluminum.....</b>	9

# STANDARD CHUCK JAWS

1.5mm x 60° Serrations

## Standard Metric Serrated Soft Jaws, Steel and Aluminum

- **Howa**
- **Kitagawa**
- **MMK**
- **Matsumoto**
- **and others**

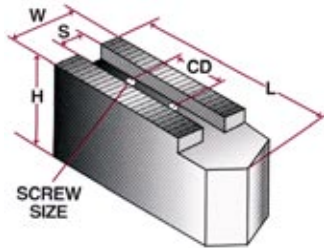

Chuck Diameter	Length	Height	Width	Slt Width	CD	Screw Size	Order # Steel	Order # Alum
4	2	1-1/8	7/8	0.394	0.552	8mm	65-04-SP	A65-04-SP
	2	1-1/8	7/8				65-04-SF	A65-04-SF
	2	2	7/8				65-04-HP	A65-04-HP
	2	2	7/8				65-04-HF	A65-04-HF
5	2-1/2	1-1/8	7/8	0.394	0.748	8mm	65-05-SP	A65-05-SP
	2-1/2	1-1/8	7/8				65-05-SF	A65-05-SF
	2-1/2	2	7/8				65-05-HP	A65-05-HP
	2-1/2	2	7/8				65-05-HF	A65-05-HF
	2-1/2	1-1/8	7/8	0.394	0.713	8mm	651-05-SP	A651-05-SP
	2-1/2	1-1/8	7/8				651-05-SF	A651-05-SF
	2-1/2	2	7/8				651-05-HP	A651-05-HP
	2-1/2	2	7/8				651-05-HF	A651-05-HF
6	3	1-1/2	1-1/8	0.434	0.985	8mm	65-06-SP	A65-06-SP
	3	1-1/2	1-1/8				65-06-SF	A65-06-SF
	3	3	1-1/8				65-06-HP	A65-06-HP
	3	3	1-1/8				65-06-HF	A65-06-HF
	3	1-1/2	1-1/8	0.473	0.787	10mm	651-06-SP	A651-06-SP
	3	1-1/2	1-1/8				651-06-SF	A651-06-SF
	3	3	1-1/8				651-06-HP	A651-06-HP
	3	3	1-1/8				651-06-HF	A651-06-HF
8	4	2	1-1/2	0.552	0.985	12mm	65-08-SP	A65-08-SP
	4	2	1-1/2				65-08-SF	A65-08-SF
	4	3	1-1/2				65-08-MP	A65-08-MP
	4	3	1-1/2				65-08-MF	A65-08-MF
	4	4	1-1/2				65-08-HP	A65-08-HP
	4	4	1-1/2	65-08-HF	A65-08-HF			
	4	2	1-1/2	0.630	0.985	12mm	650-08-SP	A650-08-SP
	4	2	1-1/2				650-08-SF	A650-08-SF
	4	4	1-1/2				650-08-HP	A650-08-HP
	4	4	1-1/2				650-08-HP	A650-08-HP
4	4	1-1/2	650-08-HF				A650-08-HF	
10	4-1/2	2	1-1/2	0.631	1.181	12mm	65-10-SP	A65-10-SP
	4-1/2	2	1-1/2				65-10-SF	A65-10-SF
	4-1/2	3	1-1/2				65-10-MP	A65-10-MP
	4-1/2	3	1-1/2				65-10-MF	A65-10-MF
	4-1/2	4	1-1/2				65-10-HP	A65-10-HP
	4-1/2	4	1-1/2				65-10-HF	A65-10-HF
10 HD-11	5	2	1-3/4	0.631	1.181	12mm	65-11-SP	A65-11-SP
	5	2	1-3/4				65-11-SF	A65-11-SF
	5	4	1-3/4				65-11-HP	A65-11-HP
	5	4	1-3/4				65-11-HF	A65-11-HF
12	5-1/2	2-1/2	2	0.710	1.181	14mm	65-12-SP	A65-12-SP
	5-1/2	2-1/2	2				65-12-SF	A65-12-SF
	5-1/2	4	2				65-12-HP	A65-12-HP
	5-1/2	4	2				65-12-HF	A65-12-HF
	5-1/2	2-1/2	2	0.826	1.181	16mm	65B-12-SP	A65B-12-SP
	5-1/2	2-1/2	2				65B-12-SF	A65B-12-SF
	5-1/2	4	2				65B-12-HP	A65B-12-HP
	5-1/2	4	2				65B-12-HF	A65B-12-HF
15	7	3	2-1/2	0.866	1.69	20mm	651-15-SP	A651-15-SP
	7	3	2-1/2				651-15-SF	A651-15-SF
	7	5	2-1/2				651-15-HP	A651-15-HP
	7	5	2-1/2				651-15-HF	A651-15-HF

**S P** – Standard Pointed  
**S F** – Standard Flat  
**H P** – High Pointed  
**H F** – High Flat

Steel Chuck Jaws made from 1018 Steel.

Aluminum Chuck Jaws made from 6061-T6

## Metric Serrated Full Circle Aluminum Jaws

- **Howa**
- **Kitagawa**
- **MMK**
- **Matsumoto**
- **and others**

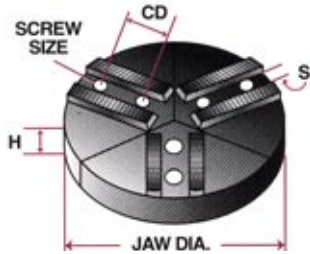

Chuck Diameter	Jaw Diameter	Height	Width	CD	Screw Size	Order # Alum
5	6"	2	0.394	0.748	8mm	A65-05-6P2
	6"	4				A65-05-6P4
	6"	2	0.394	0.713	8mm	A651-05-6P2
	6"	4				A651-05-6P4
6	6"	2	0.434	0.985	8mm	A65-06-P2
	6"	4				A65-06-P4
	8"	2				A65-06-8P2
	8"	4				A65-06-8P4
	6"	2	0.473	0.790	10mm	A651-06-P2
	6"	4				A651-06-P4
	8"	2				A651-06-8P2
	8"	4				A651-06-8P4
8	8"	2	0.552	0.985	12mm	A65-08-P2
	8"	4				A65-08-P4
	10"	2				A65-08-10P2
	10"	4				A65-08-10P4
	8"	2	0.630	0.985	12mm	A650-08-P2
	8"	4				A650-08-P4
	10"	2				A650-08-10P2
	10"	4				A650-08-10P4
10	10"	2	0.631	1.181	12mm	A65-10-P2
	10"	4				A65-10-P4
	12"	2-1/2				A65-10-12P2.5
	12"	4				A65-10-12P4
12	12"	2-1/2	0.710	1.181	14mm	A65-12-P2.5
	12"	4				A65-12-P4
	15"	2-1/2				A65-12-15P2.5
	15"	4				A65-12-15P4
	12"	2-1/2	0.826	1.181	16mm	A65B-12-P2.5
	12"	4				A65B-12-P4
	15"	2-1/2				A65B-12-15P2.5
	15"	4				A65B-12-15P4
15	15"	2-1/2	0.866	1.690	20mm	A651-15-P2.5
	15"	4				A651-15-P4
	18"	2.5				A651-15-18P2.5
	18"	4				A651-15-18P4

Aluminum Chuck Jaws and Full Circle Jaws made from 6061-T6

# STANDARD CHUCK JAWS

3mm x 60° Serrations

## Standard Metric Serrated Soft Jaws, Steel and Aluminum

Chuck Diameter	Length	Height	Width	Slit Width	CD	Screw Size	Order # Steel	Order # Alum
8	4	1-3/4	1-1/2	0.552	0.985	12mm	73-08-SP	A73-08-SP
	4	1-3/4	1-1/2				73-08-SF	A73-08-SF
	4	3-1/2	1-1/2				73-08-HP	A73-08-HP
	4	3-1/2	1-1/2				73-08-HF	A73-08-HF
10	4-1/2	2	1-1/2	0.631	1.181	12mm	73-10-SP	A73-10-SP
	4-1/2	2	1-1/2				73-10-SF	A73-10-SF
	4-1/2	4	1-1/2				73-10-HP	A73-10-HP
	4-1/2	4	1-1/2				73-10-HF	A73-10-HF
12	5-1/2	2-1/2	2	0.710	1.181	14mm	73-12-SP	A73-12-SP
	5-1/2	2-1/2	2				73-12-SF	A73-12-SF
	5-1/2	4	2				73-12-HP	A73-12-HP
	5-1/2	4	2				73-12-HF	A73-12-HF
15	7	3	2-1/2	0.867	1.968	20mm	73-15-SP	A73-15-S0
	7	3	2-1/2				73-15-SF	A73-15-SF
	7	5	2-1/2				73-15-HP	A73-15-HP
	7	5	2-1/2				73-15-HF	A73-15-HF
18	7-1/2	3	2-1/2	0.985	2.362	20mm	73-18-SP	A73-18-SP
	7-1/2	3	2-1/2				73-18-SF	A73-18-SF
	7-1/2	5	2-1/2				73-18-HP	A73-18-HP
	7-1/2	5	2-1/2				73-18-HF	A73-18-HF

- Howa
- Kitagawa
- MMK
- Matsumoto
- and others

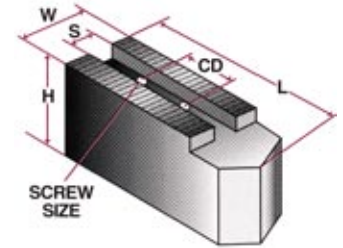

SP – Standard Pointed  
 SF – Standard Flat  
 HP – High Pointed  
 HF – High Flat

## Metric Serrated Full Circle Aluminum Jaws

Chuck Diameter	Jaw Diameter	Height	Slit Width	CD	Screw Size	Order # Alum
8	8"	2	0.552	0.985	12mm	A73-08-P2
	8"	4				A73-08-P4
	10"	2				A73-08-10P2
	10"	4				A73-08-10P4
10	10"	2	0.631	1.181	12mm	A73-10-P2
	10"	4				A73-10-P4
	12"	2-1/2				A73-10-12P2.5
	12"	4				A73-10-12P4
12	12"	2-1/2	0.710	1.181	14mm	A73-12-P2.5
	12"	4				A73-12-P4
	15"	2-1/2				A73-12-15P2.5
	15"	4				A73-12-15P4
15	15"	3	0.867	1.968	20mm	A73-15-P3
	15"	4				A73-15-P4
	18"	3				A73-15-18P3
	18"	4				A73-15-18P4
18	18"	3	0.985	2.362	20mm	A73-18-P3
	18"	4				A73-18-P4
	24"	4				A73-18-24P4

- Howa
- Kitagawa
- MMK
- Matsumoto
- and others

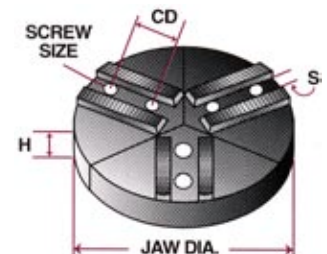

Steel Chuck Jaws made from 1018 Steel.

Aluminum Chuck Jaws and Full Circle Jaws made from 6061-T6

# STANDARD CHUCK JAWS

1.5mm x 60° Serrations  
(15" Chuck has a 3mm Serration)

## Standard Metric Serrated Soft Jaws, Steel and Aluminum

### Hitachi Seiki Chucks

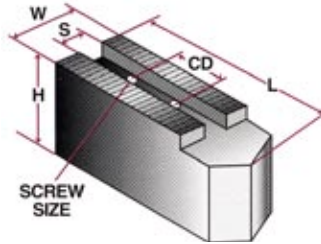

**S P** – Standard Pointed  
**S F** – Standard Flat  
**H P** – High Pointed  
**H F** – High Flat

Chuck Diameter	Length	Height	Width	Slt Width	CD	Screw Size	Order # Steel	Order # Alum
6	3	1-1/2	1-1/8	0.434	0.985	8mm	65-06-SP	A65-06-SP
	3	1-1/2	1-1/8				65-06-SF	A65-06-SF
	3	3	1-1/8				65-06-HP	A65-06-HP
	3	3	1-1/8				65-06-HF	A65-06-HF
10	4-1/2	2	1-1/2	.631	1.26	12mm	85-10-SP	A85-10-SP
	4-1/2	2	1-1/2				85-10-SF	A85-10-SF
	4-1/2	4	1-1/2				85-10-HP	A85-10-HP
	4-1/2	4	1-1/2				85-10-HF	A85-10-HF
12	5-1/2	2-1/2	2	0.710	1.26	14mm	85-12-SP	A85-12-SP
	5-1/2	2-1/2	2				85-12-SF	A85-12-SF
	5-1/2	4	2				85-12-HP	A85-12-HP
	5-1/2	4	2				85-12-HF	A85-12-HF
15	7	3	2-1/2	0.867	1.968	20mm	85-15-SP	A85-15-SP
	7	3	2-1/2				85-15-SF	A85-15-SF
	7	5	2-1/2				85-15-HP	A85-15-HP
	7	5	2-1/2				85-15-HF	A85-15-HF

## Metric Serrated Full Circle Aluminum Jaws

### Hitachi Seiki Chucks

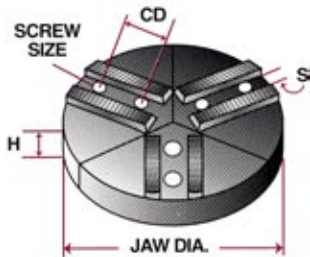

Chuck Diameter	Jaw Diameter	Height	Slt Width	CD	Screw Size	Order # Alum
6	6"	2	0.434	0.985	8mm	A65-06-P2
	6"	4				A65-06-P4
	8"	2				A65-06-8P2
	8"	4				A65-06-8P4
10	10"	2	0.631	1.26	12mm	A85-10-P2
	10"	4				A85-10-P4
	12"	2-1/2				A85-10-12P2.5
	12"	4				A85-10-12P4
12	12"	2-1/2	0.710	1.26	14mm	A85-12-P2.5
	12"	4				A85-12-P4
	15"	2-1/2				A85-12-15P2.5
	15"	4				A85-12-15P4
15	15"	2-1/2	0.867	1.968	20mm	A85-15-P2.5
	15"	4				A85-15-P4
	18"	2-1/2				A85-15-18P3
	18"	4				A85-15-18P4

Steel Chuck Jaws made from 1018 Steel.

Aluminum Chuck Jaws and Full Circle Jaws made from 6061-T6

# STANDARD CHUCK JAWS

.0625 x 90° Serrations

## Standard English Serrated Soft Jaws

Chuck Diameter	Length	Height	Width	Slit Width	CD	Screw Size	Order # Steel	Order # Alum
5	2-1/2	1-1/8	1	0.433	0.710	5/16"	50-05-SP	A50-050SP
	2-1/2	1-1/8	1				50-05-SF	A50-05-SF
	2-1/2	2	1				50-05-HP	A50-05-HP
	2-1/2	2	1				50-05-HF	A50-05-HF
6	3	1-1/2	1-1/8	0.433	0.790	5/16"	50-06-SP	A50-06-SP
	3	1-1/2	1-1/8				50-06-SF	A50-06-SF
	3	3	1-1/8				50-06-HP	A50-06-HP
	3	3	1-1/8				50-06-HF	A50-06-HF
	3	1-1/2	1-1/8	0.551	0.710	3/8"	501-06-SP	A501-06-SP
	3	1-1/2	1-1/8				501-06-SF	A501-06-SF
	3	3	1-1/8				501-06-HP	A501-06-HP
	3	3	1-1/8				501-06-HF	A501-06-HF
8-10	4	1-3/4	1-1/2	0.551	0.870	3/8"	50-08-SP	A50-08-SP
	4	1-3/4	1-1/2				50-08-SF	A50-08-SF
	4	3-1/2	1-1/2				50-08-HP	A50-08-HP
	4	3-1/2	1-1/2				50-08-HF	A50-08-HF
	4-1/2	2	1-1/2				50-09-SP	A50-09-SP
	4-1/2	2	1-1/2				50-09-SF	A50-09-SF
	4-1/2	4	1-1/2				50-09-HP	A50-09-HP
	4-1/2	4	1-1/2				50-09-HF	A50-09-HF
10 HD	4-1/2	2	1-3/4	0.788	1.180	1/2"	50-10-SP	A50-10SP
	4-1/2	2	1-3/4				50-10-SF	A50-10-SF
	4-1/2	4	1-3/4				50-10-HP	A50-10-HP
	4-1/2	4	1-3/4				50-10-HF	A50-10-HF
11 and 12	5-1/2	2	2	0.788	1.180	1/2"	50-12-SP	A50-12-SP
	5-1/2	2	2				50-12-SF	A50-12-SF
	5-1/2	4	2				50-12-HP	A50-12-HP
	5-1/2	4	2				50-12-HF	A50-12-HF

- Gamet
- Power Hold
- Rohm
- and others

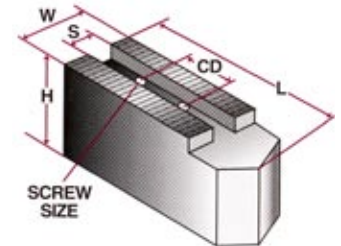

## Standard English Serrated Soft Jaws, Steel and Aluminum

Chuck Diameter	Length	Height	Width	Slit Width	CD	Screw Size	Order # Steel	Order # Alum
6	3	1-1/2	1/4	0.552	0.875	5/16"	40-06-SP	A40-06-SP
	3	1-1/2	1/4				40-06-SF	A40-06-SF
	3	3	1/4				40-06-HP	A40-06-HP
	3	3	1/4				40-06-HF	A40-06-HF
8	4	1-3/4	1-1/2	0.669	0.875	1/2"	40-08-SP	A40-08-SP
	4	1-3/4	1-1/2				40-08-SF	A40-08-SF
	4	3-1/2	1-1/2				40-08-HP	A40-08-HP
	4	3-1/2	1-1/2				40-08-HF	A40-08-HF
10	4-1/2	2-1/4	1-3/4	0.827	1.187	1/2"	40-10-SP	A40-10-SP
	4-1/2	2-1/4	1-3/4				40-10-SF	A40-10-SF
	4-1/2	4	1-3/4				40-10-HP	A40-10-HP
	4-1/2	4	1-3/4				40-10-HF	A40-10-HF
12	5-1/2	2-1/2	1-3/4	0.827	1.187	1/2"	40-12-SP	A40-12-SP
	5-1/2	2-1/2	1-3/4				40-12-SF	A40-12-SF
	5-1/2	4	1-3/4				40-12-HP	A40-12-HP
	5-1/2	4	1-3/4				40-12-HF	A40-12-HF

- SMW
- Autoblock

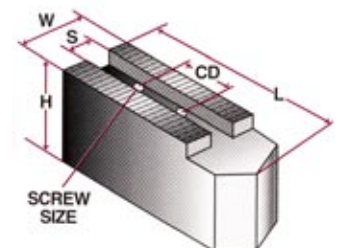

- SP – Standard Pointed
- SF – Standard Flat
- HP – High Pointed
- HF – High Flat

Steel Chuck Jaws made from 1018 Steel.

Aluminum Chuck Jaws made from 6061-T6

- Gamet
- Power Hold
- Rohm
- and others

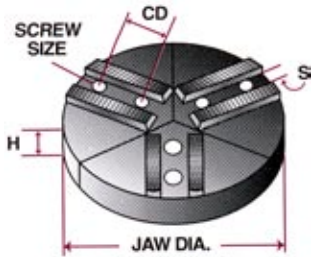

## English Serrated Full Circle Aluminum Jaws

Chuck Diameter	Jaw Diameter	Height	Slit Width	CD	Screw Size	Order # Alum
5	6"	2	0.433	0.710	5/16"	A50-05-6P2
	6"	4				A50-05-6P4
6	6"	2	0.433	0.790	5/16"	A50-06-P2
	6"	4				A50-06-P4
	8"	2				A50-06-8P2
	8"	4				A50-06-8P4
	6"	2	0.551	0.710	3/8"	A501-06-P2
	6"	4				A501-06-P4
8"	2	A501-06-8P2				
8"	4	A501-06-8P4				
8-10 1/2	8"	2	0.551	0.870	3/8"	A50-08-P2
	8"	4				A50-08-P4
	10	2				A50-08-10-P2
	10	4				A50-08-10P4
10 HD	10"	2	.788	1.180	1/2"	A50-10-P2
	10"	4				A50-10-P4
	12"	2-1/2				A50-10-12P2.5
	12"	2-1/4				A50-12-P4
11 and 12	12"	2-1/2	.788	1.180	1/2"	A50-12-P2.5
	12"	4				A50-12-P4
	15"	2-1/2				A50-12-15P2.5
	15"	4				A50-12-15P4

## English Serrated Full Circle Aluminum Jaws

- SMW
- Autoblock

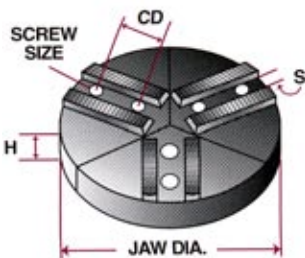

Chuck Diameter	Jaw Diameter	Height	Slit Width	CD	Screw Size	Order # Alum
6	6"	2	.552	.875	5/16"	A40-06-P2
	6"	4				A40-06-P4
	8"	2				A40-06-8P2
	8"	4				A40-06-8P4
8	8"	2	.669	.875	1/2"	A40-08-P2
	8"	4				A40-08-P4
	10"	2				A40-08-10P2
	10"	4				A40-08-10P4
10 and 12	10"	2	.827	1.187	1/2"	A40-10-P2
	10"	4				A40-10-P4
	12"	2-1/2				A40-10-12P2.5
	12"	4				A40-10-12P4

Aluminum Chuck Jaws and Full Circle Jaws made from 6061-T6



# AMERICAN STANDARD TONGUE & GROOVE JAWS

## American Standard Medium Duty Tongue & Groove Jaws

Chuck Diameter	Length	Height	Width	Slit Width	CD	Tongue Size	Screw Size	Order # Steel	Order # Alum
6	3	1-1/2	1	.738	1-11/16	.377	5/16	7-06-SP	A7-06-SP
	3	1-1/2	1					7-06-SF	A7-06-SF
	3	3	1					7-06-HP	A7-06-HP
	3	3	1					7-06-HF	A7-06-HF
	3	1-1/2	1	.312	1-1/2	1/2	3/8	1-06-SP	A1-06-SP
	3	1-1/2	1					1-06-SF	A1-06-SF
	3	3	1					1-06-HP	A1-06-HP
	3	3	1					1-06-HF	A1-06-HF
8	3-3/4	2	1-1/2	.312	1-3/4	1/2	3/8	1-08-SP	A1-08-SP
	3-3/4	2	1-1/2					1-08-SF	A1-08-SF
	3-3/4	4	1-1/2					1-08-HP	A1-08-HP
	3-3/4	4	1-1/2					1-08-HF	A1-08-HF
10	4-1/2	2	1-1/2	.500	2-1/8	3/4	1/2	1-10-SP	A1-10-SP
	4-1/2	2	1-1/2					1-10-SF	A1-10-SF
	4-1/2	4	1-1/2					1-10-HP	A1-10-HP
	4-1/2	4	1-1/2					1-10-HF	A1-10-HF
	4-1/2	2	2					1-10-SP2	A1-10-SP2
	4-1/2	2	2					1-10-SF2	A1-10-SF2
	4-1/2	4	2					1-10-HP2	A1-10-HP2
	4-1/2	4	2					1-10-HF2	A1-10-HF2
12	5-1/4	2	2	.500	2-1/2	3/4	1/2	1-12-SP	A1-12-SP
	5-1/4	2	2					1-12-SF	A1-12-SF
	5-1/4	4	2					1-12-HP	A1-12-HP
	5-1/4	4	2					1-12-HF	A1-12-HF

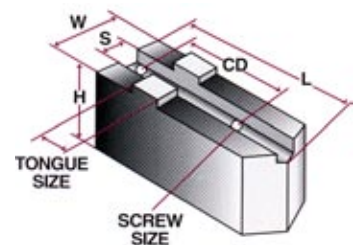
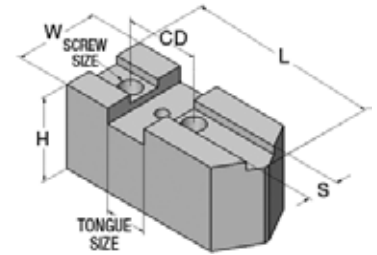

EXPANDING COLLETS	WORK HOLDING	SPECIAL TOOLING
<p>For 5C, 16C, and 3J Spindles .065" - .250"</p> <p>Mini Expanding Collets</p>	<p>Wide Variety of Sizes</p> <p>Tool Holders</p>	<p>Twister Speed Lathes</p> <p>AccuTapper</p>
<p>For 5C, 16C, and 3J Spindles .250" - 6"</p> <p>Heavy Duty Expanding Collets</p>	<p>For 5C and 16C Spindles</p> <p>Collets</p>	<p>Tapping &amp; Chasing Threads</p> <p>Bar Pullers</p>

**S P** – Standard Pointed  
**S F** – Standard Flat  
**H P** – High Pointed  
**H F** – High Flat

Steel Chuck Jaws made from 1018 Steel.

Aluminum Chuck Jaws made from 6061-T6

# AMERICAN STANDARD TONGUE & GROOVE JAWS

## American Standard Medium Duty Tongue & Groove Full Circle Jaws

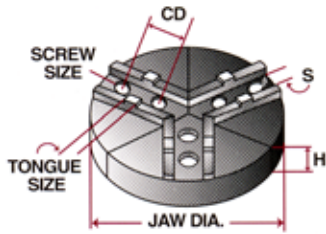

Chuck Diameter	Jaw Diameter	Height	Slit	CD	Tongue Size	Screw Size	Order # Alum	
6	6	2	0.738	1-11/16	.377	5/16	A7-06-P2	
	6	4				5/16	A7-06-P4	
	8	2				5/16	A7-06-8P2	
	8	4				5/16	A7-06-8P4	
	6	2	0.312			1-1/2	3/8	A1-06-P2
	6	4					3/8	A1-06-P4
	8	2					3/8	A1-06-8P2
	8	4					3/8	A1-06-8P4
8	8	2	0.312	1-3/4	1/2	3/8	A1-08-P2	
	8	4				3/8	A1-08-P4	
	10	2				3/8	A1-08-10P2	
	10	4				3/8	A1-08-10P4	
10	10	2	.500	2-1/8	3/4	1/2	A1-10-P2	
	10	4				1/2	A1-10-P4	
	12	2-1/2				1/2	A1-10-12P2.5	
	12	4				1/2	A1-10-12P4	
12	12	2-1/2	.500	2-1/2	3/4	1/2	A1-12-P2.5	
	12	4				1/2	A1-12-P4	
	15	2-1/2				1/2	A1-12-15P2.5	
	15	4				1/2	A1-12-15P4	

Aluminum Chuck Jaws and Full Circle Jaws made from 6061-T6

# ROVI

High Quality Machine Tool Products

Designed to Meet Your Specifications

Service That Exceeds Your Expectations

## Look to ROVI for all your Machine Tool Needs including:

- Chuck Jaws
- Expanding Collets
- Collets
- Chucks and Collet Chucks
- Cutting Tools
- Bushing and Tool Holders
- Special Tooling
- Speed Lathes

1. Rigid One Piece Key Pin. Assures accuracy, minimizes wear for long lasting use.
2. Hardened and Ground Sleeves with Nylon Pins for 5C, 16C and 3J Spindles — Assures an exact fit and repeatable accuracy every time.
3. Expanding Collet Taper. Locks solidly with sleeve — for rigidity plus fast and accurate set-ups.
4. Available Sizes from .065" to 6" Diameter. Holds linear dimensions plus meets all your production size requirements.
5. Exclusive Three Part System. Assures long term economy and value.
6. Operator Friendly Fast, Easy & Save to Use. ROVI Expanding Collets will rapidly become your machinist's favorite.
7. Holds Accurate Dimensional Tolerances. .005" T.I.R. or better!
8. Machinable Steel. Holds memory for assured repeatability.
9. Warrantied. The ROVI Warranty will assure your satisfaction.
10. Complete Inventory. Assures rapid response with friendly service.

# STANDARD CHUCK JAWS

## American Standard Heavy Duty Tongue & Groove Jaws

Chuck Diameter	Length	Height	Width	Slt Width	CD	Tongue Size	Screw Size	Order # Steel	Order # Alum
6	3	1-1/2	1	.312	1-1/2	1/2	7/16	3-06-SP	A3-06-SP
	3	1-1/2	1					3-06-SF	A3-06-SF
	3	3	1					3-06-HP	A3-06-HP
	3	3	1					3-06-HF	A3-06-HF
8	3-3/4	2	1-1/2	.312	1-3/4	1/2	1/2	3-08-SP	A3-08-SP
	3-3/4	2	1-1/2					3-08-SF	A3-08-SF
	3-3/4	4	1-1/2					3-08-HP	A3-08-HP
	3-3/4	4	1-1/2					3-08-HF	A3-08-HF
10	4-1/2	2	2	.500	2-1/8	3/4	5/8	3-10-SP	A3-10-SP
	4-1/2	2	2					3-10-SF	A3-10-SF
	4-1/2	4	2					3-10-HP	A3-10-HP
	4-1/2	4	2					3-10-HF	A3-10-HF
12	5-1/4	2	2	.500	2-1/2	3/4	5/8	3-12-SP	A3-12-SP
	5-1/4	2	2					3-12-SF	A3-12-SF
	5-1/4	4	2					3-12-HP	A3-12-HP
	5-1/4	4	2					3-12-HF	A3-12-HF

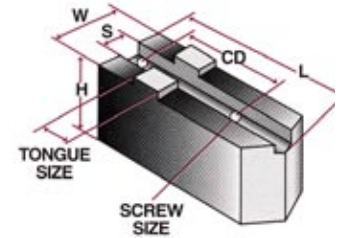

**S P** – Standard Pointed  
**S F** – Standard Flat  
**H P** – High Pointed  
**H F** – High Flat

## American Standard Heavy Duty Tongue & Groove Full Circle Jaws

Chuck Diameter	Jaw Diameter	Height	Slt	CD	Tongue Size	Screw Size	Order # Steel	Order # Alum
6	6	2	.312	1-1/2	1/2	7/16	A3-06-P2	
	6	4					A3-06-P4	
	8	2					A3-06-8P2	
	8	4					A3-06-8P4	
8	8	2	.312	1-3/4	1/2	1/2	A3-08-P2	
	8	4					A3-08-P4	
	10	2					A3-08-10P2	
	10	4					A3-08-10P4	
10	10	2	.500	2-1/8	3/4	5/8	A3-10-P2	
	10	4					A3-10-P4	
	12	2-1/2					A3-10-12P2.5	
	12	4					A3-10-12P4	
12	12	2-1/2	.500	2-1/2	3/4	5/8	A3-12-P2.5	
	12	4					A3-12-P4	
	15	2-1/2					A3-12-15P2.5	
	15	4					A3-12-15P4	

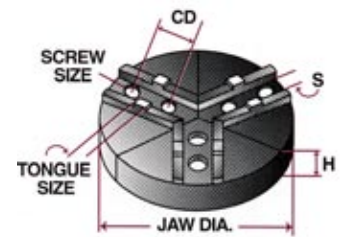

Steel Chuck Jaws made from 1018 Steel.

Aluminum Chuck Jaws made from 6061-T6

## CUTTING TOOLS

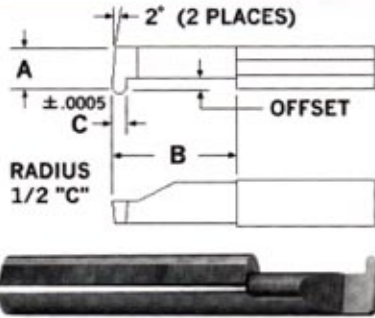

**Groove Tools**

## WORK HOLDING

Wide Variety of Sizes & Styles



**Collet Chucks**

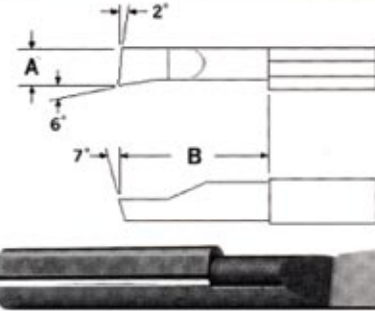

**Boring Bars**



**Bar Pullers**

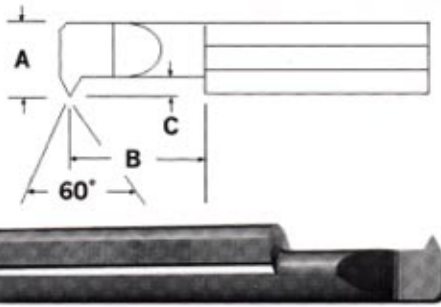

**Threading Tools**

Power and Manual



**Power Chucks**

# ROVI<sup>®</sup>

PRODUCTS  
INCORPORATED  
MACHINE TOOLS  
SPECIALTIES

4648 Runway Street  
Simi Valley, CA 93063-3450  
800-423-5145  
Tel. 805-582-0165 Fax 805-582-1530  
www.roviproducts.com  
Email: info@roviproducts.com