



MERCER VALVE CO., INC.®
"AUTO SEAT TECHNOLOGY"®

9100 SERIES Flanged



THINK...MERCER FIRST®



MERCER VALVE



9100 Series Product Overview

The Mercer Valve 9100 Series Pressure Relief Valve is "State of the Art" in soft seat, high flow rate, pressure relieving devices. The 9100 Series is a continuation of the 8100 Series incorporating our patented "Auto Seat Technology"® into its design.

Mercer Valve's "Auto Seat Technology"® has made the 9100 Series an industry leader with its reliable, repeatable set pressures.

The patented soft seat design and fully guided disk allow the valve to continually outlast the competition. The soft seat 9100 Series has a field-proven lip seal design, which allows for a tighter seal up to set pressure. This tight seal reduces leaks and limits product loss. The 9100 Series is manufactured in accordance with the requirements of ASME Boiler and Pressure Vessel Code, Section VIII, Division 1 for Air/Gas and Liquid service. The 9100 Series is well suited for specialty gases, compressors, separators, transmission, gathering lines and other production processes.



9100 Series Features

- **Designed with "Auto Seat Technology"®.**
- **Consistent Set Pressures allowing repeatable uses without repair or resetting.**
- **Open, Close, Seat and Seal™.**
- **Fully guided disk keeps the disk properly aligned, opening and closing, helping to reset the valve.**
- **Mechanical Stop prevents wear on parts and controls valve lift.**
- **Low rated and fully guided spring allows for more consistent set pressures from pop to pop.**
- **Pop Action relief allows valve to go to full lift at set pressure. Helps with DOT regulated applications.**
- **Built in accordance with the requirements of ASME Boiler and Pressure Vessel Code. Sec. VIII Div 1.**
- **Non-rising stems allowing valves to be installed in small areas.**



9100 Series Flanged Specifications

Orifice Letter	C	D	E	F	G	H	J	K	L	M
Standard Inlet Sizes	3/4" 1"	3/4" 1" 1 1/2"	1" 1 1/2"	1" 1 1/2"	1 1/2" 2"	1 1/2" 2"	2" 3"	3"	3" 4"	4"
Inlet and Outlet Connection Types Available	RF x RF , RTJ x RF , RTJ x RTJ									
Actual Orifice Diameter (in)	.281	.394	.520	.655	.775	1.050	1.350	1.625	2.020	2.280
Actual Orifice Area (in²)	.062	.122	.212	.337	.472	.865	1.430	2.074	3.205	4.080
API Orifice Area (in²)	---	.110	.196	.307	.503	.785	1.287	1.838	2.853	3.600
Pressure Ranges (psi)	15 to 2999	15 to 2999	15 to 2400	15 to 2400	15 to 2000	15 to 2000	15 to 1800	15 to 1500	15 to 1250	15 to 1000
Standard Temperature Range (°F)	-20 to 400	-20 to 400	-20 to 400	-20 to 400	-20 to 400	-20 to 400	-20 to 400	-20 to 400	-20 to 400	-20 to 400
ASME Flow Coefficient, K_d (Gas)	.818	.818	.818	.818	.818	.818	.818	.818	.818	.818
ASME Flow Coefficient, K_d (Liquid)	.707	.707	.707	.707	.707	.707	.707	.707	.707	.707

NOTE: Mercer Valve reserves the right to change product designs and specifications without notice.

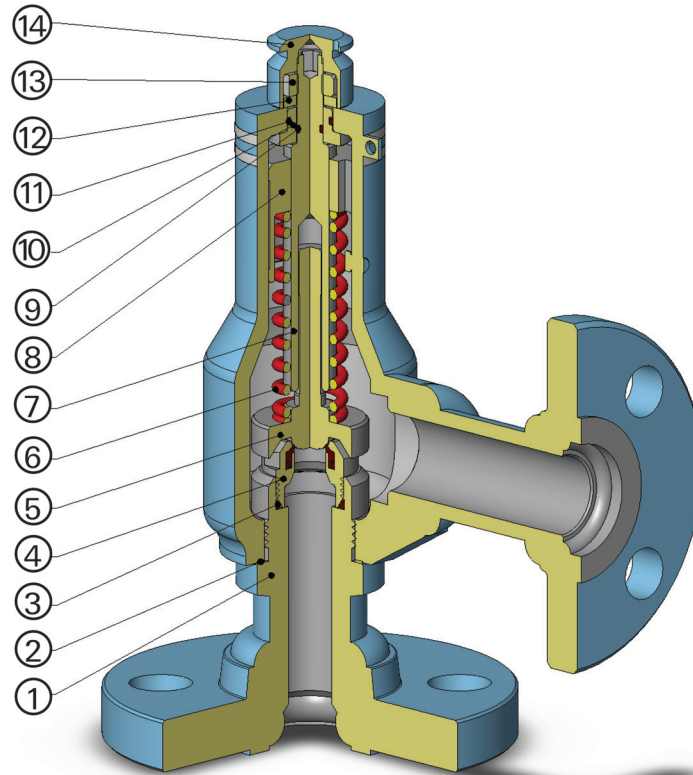

9100 SERIES FLANGED C , D , & E ORIFICES

ITEM NO	PART NAME	STANDARD MATERIALS
1	BODY SUBASSEMBLY	CARBON STEEL
2	BASE SEAL	SOFT STEEL
3	NOZZLE O-RING	FLUOROCARBON (FKM)
4	NOZZLE SUBASSEMBLY	STAINLESS STEEL WITH SOFT SEAT
5	DISK SUBASSEMBLY	STAINLESS STEEL
6	SET SPRING	STAINLESS STEEL
7	ADJUSTMENT SCREW	STAINLESS STEEL
8	ADJUSTMENT BUSHING	STAINLESS STEEL
9	ADJUSTMENT SCREW O-RING	BUNA N
10	CENTER BUSHING	STAINLESS STEEL
11	CENTER BUSHING O-RING	BUNA N
12	WASHER	CARBON STEEL
13	LOCKNUT	CARBON STEEL
14	CLOSED CAP	ALUMINUM ALLOY

NOTE: Mercer Valve reserves the right to change product designs and specifications without notice.

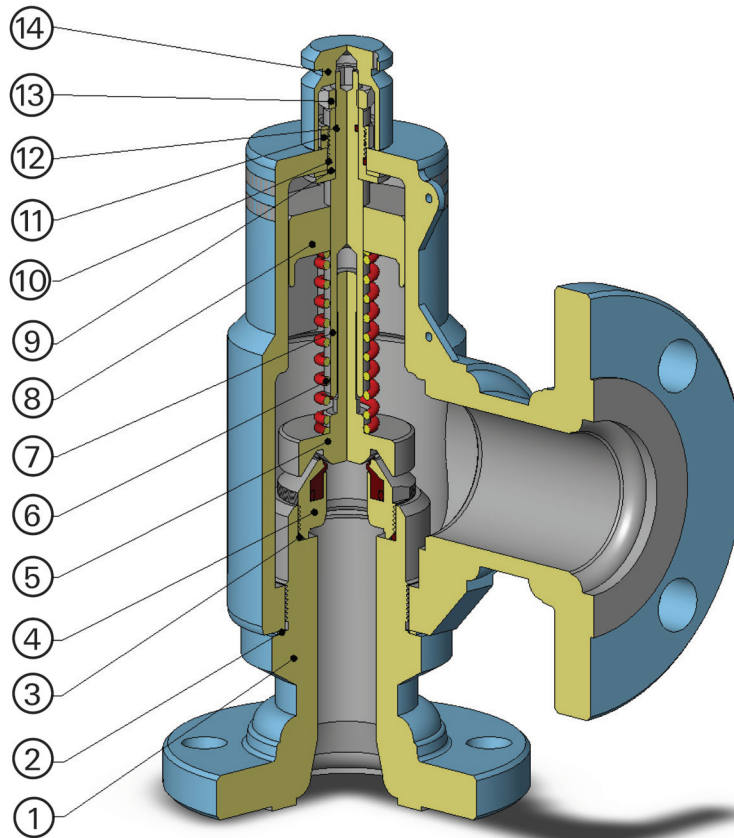

9100 SERIES FLANGED F & G ORIFICES

ITEM NO	PART NAME	STANDARD MATERIALS
1	BODY SUBASSEMBLY	CARBON STEEL
2	BASE SEAL	SOFT STEEL
3	NOZZLE O-RING	FLUOROCARBON (FKM)
4	NOZZLE SUBASSEMBLY	STAINLESS STEEL WITH SOFT SEAT
5	DISK SUBASSEMBLY	STAINLESS STEEL
6	SET SPRING	STAINLESS STEEL
7	ADJUSTMENT SCREW	STAINLESS STEEL
8	ADJUSTMENT BUSHING	STAINLESS STEEL
9	CENTER BUSHING	STAINLESS STEEL
10	CENTER BUSHING O-RING	BUNA N
11	CENTER NUT	CARBON STEEL
12	ADJUSTMENT SCREW O-RING	BUNA N
13	LOCKNUT	CARBON STEEL
14	CLOSED CAP	ALUMINUM ALLOY

NOTE: Mercer Valve reserves the right to change product designs and specifications without notice.

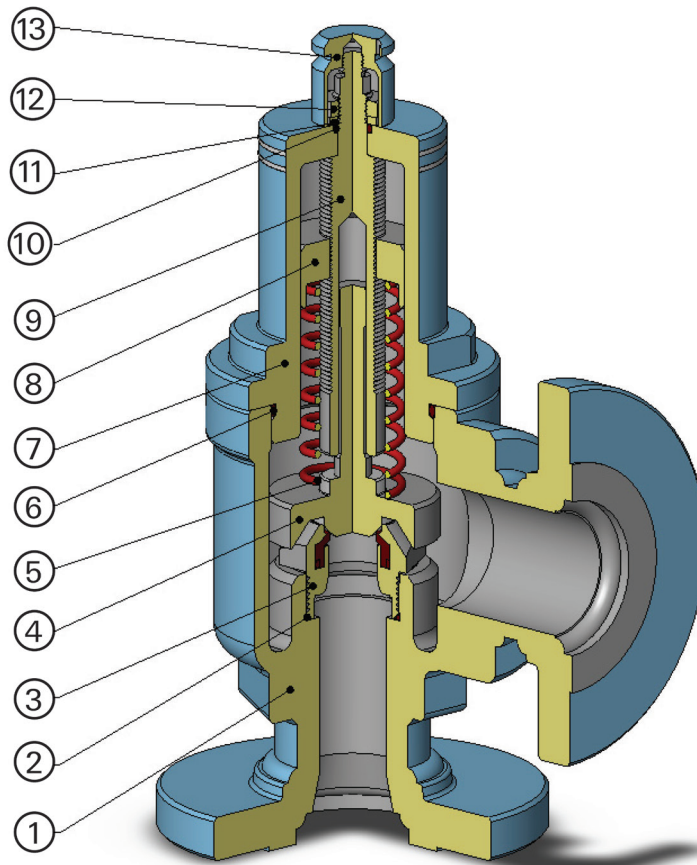

9100 SERIES FLANGED H ORIFICE

ITEM NO	PART NAME	STANDARD MATERIALS
1	BODY SUBASSEMBLY	CARBON STEEL
2	NOZZLE O-RING	FLUOROCARBON (FKM)
3	NOZZLE SUBASSEMBLY	STAINLESS STEEL WITH SOFT SEAT
4	DISK SUBASSEMBLY	STAINLESS STEEL
5	SET SPRING	STAINLESS STEEL
6	BONNET O-RING	BUNA N
7	BONNET	CARBON STEEL
8	ADJUSTMENT BUSHING	STAINLESS STEEL
9	ADJUSTMENT SCREW	STAINLESS STEEL
10	ADJUSTMENT SCREW O-RING	BUNA N
11	WASHER	CARBON STEEL
12	LOCKNUT	CARBON STEEL
13	CLOSED CAP	ALUMINUM ALLOY

NOTE: Mercer Valve reserves the right to change product designs and specifications without notice.

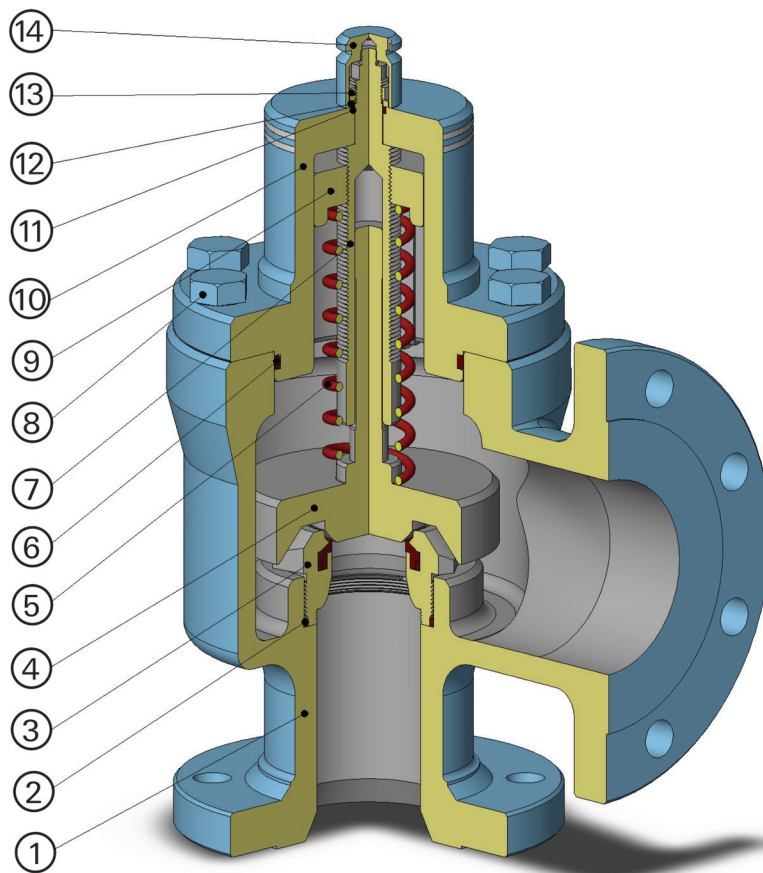

9100 SERIES FLANGED J, K, L, & M ORIFICES

ITEM NO	PART NAME	STANDARD MATERIALS
1	BODY SUBASSEMBLY	CARBON STEEL
2	NOZZLE O-RING	FLUOROCARBON (FKM)
3	NOZZLE SUBASSEMBLY	STAINLESS STEEL WITH SOFT SEAT
4	DISK SUBASSEMBLY	STAINLESS STEEL
5	SET SPRING	STAINLESS STEEL
6	BONNET O-RING	BUNA N
7	ADJUSTMENT SCREW	STAINLESS STEEL
8	BONNET BOLTS	ALLOY STEEL
9	ADJUSTMENT BUSHING	STAINLESS STEEL
10	BONNET SUBASSEMBLY	CARBON STEEL
11	ADJUSTMENT SCREW O-RING	BUNA N
12	WASHER	CARBON STEEL
13	LOCKNUT	CARBON STEEL
14	CLOSED CAP	ALUMINUM ALLOY

NOTE: Mercer Valve reserves the right to change product designs and specifications without notice.



INLET-OUTLET CODE	VALVE SIZE AND FLANGE RATING INLET X OUTLET	AVAILABLE ORIFICE SIZE	PRESSURE RANGE (psig) C.S. @100° F	CENTER TO FACE DIMENSIONS (IN.) +/- 1/16 INLET X OUTLET X HT. "A" X "B" X "C"	APPROX. WEIGHT (lbs.)
11	3/4" 150 X 1" 150	C,D	15-285	4 1/8 X 4 1/2 X 9	9
12	3/4" 300 X 1" 150	C,D	286-740	4 1/8 X 4 1/2 X 9	10
13	3/4" 600 X 1" 150	C,D	741-1480	4 1/8 X 4 1/2 X 9	11
14	3/4" 900 X 1" 300	C,D	1481-2220	4 1/8 X 4 1/2 X 9	14
15	3/4" 1500 X 1" 300	C,D	2221-2999	4 1/8 X 4 1/2 X 9	14
16	1" 150 X 1" 150	C,D,E	15-285	4 1/8 X 4 1/2 X 9	9
17	1" 300 X 1" 150	C,D,E	286-740	4 1/8 X 4 1/2 X 9	11
18	1" 600 X 1" 150	C,D,E	741-1480	4 1/8 X 4 1/2 X 9	11
19	1" 900 X 1" 300	C,D	1481-2220	4 1/8 X 4 1/2 X 9	16
21	1" 1500 X 1" 300	C,D	2221-2999	4 1/8 X 4 1/2 X 9	16
22	1" 150 X 1 1/2" 150	D,E	15-285	4 1/8 X 4 1/2 X 9	11
23	1" 300 X 1 1/2" 150	D,E	286-740	4 1/8 X 4 1/2 X 9	13
24	1" 600 X 1 1/2" 150	D,E	741-1480	4 7/8 X 4 1/2 X 10 1/2	13
25	1" 900 X 1 1/2" 300	D,E	1481-2220	5 7/8 X 5 1/2 X 11 1/2	27
26	1" 1500 X 1 1/2" 300	D,E	2221-2400	5 7/8 X 5 1/2 X 11 1/2	27
22	1" 150 X 1 1/2" 150	F	15-285	4 1/8 X 4 3/4 X 9 3/4	18
23	1" 300 X 1 1/2" 150	F	286-740	4 1/2 X 4 3/4 X 10 1/8	19
24	1" 600 X 1 1/2" 150	F	741-1480	5 1/4 X 4 3/4 X 10 7/8	20
27	1" 150 X 2" 150	D*,E*	15-285	4 1/8 X 4 1/2 X 9	14
28	1" 300 X 2" 150	D*,E*	286-740	4 1/8 X 4 1/2 X 9	15
29	1" 600 X 2" 150	D*	741-1480	4 1/8 X 4 1/2 X 9	15
29	1" 600 X 2" 150	E	741-1480	5 1/4 X 4 1/2 X 10 7/8	21
31	1" 900 X 2" 300	D,E	1481-2220	5 1/4 X 5 1/2 X 10 7/8	28
32	1" 1500 X 2" 300	D	2221-2999	5 1/4 X 5 1/2 X 10 7/8	28
32	1" 1500 X 2" 300	E	2221-2400	5 1/4 X 5 1/2 X 10 7/8	28
33	1 1/2" 150 X 2" 150	F*,G	15-285	4 7/8 X 4 3/4 X 10 1/2	22
34	1 1/2" 300 X 2" 150	F*,G	286-740	4 7/8 X 6 X 10 1/2	25
35	1 1/2" 600 X 2" 150	F*,G	741-1480	4 7/8 X 6 X 10 1/2	26
36	1 1/2" 900 X 2" 300	F,G	1481-2220	5 7/8 X 6 X 11 1/2	34
36	1 1/2" 900 X 2" 300	D*,E*	1481-2220	4 1/8 X 5 1/2 X 9 3/4	31
92	1 1/2" 1500 X 2" 300	D*	2221-2999	4 1/8 X 5 1/2 X 9 3/4	31
92	1 1/2" 1500 X 2" 300	E*	2221-2400	4 1/8 X 5 1/2 X 9 3/4	31
33	1 1/2" 150 X 2" 150	H	15-285	4 7/8 X 4 3/4 X 12 5/8	35
34	1 1/2" 300 X 2" 150	H	286-740	4 7/8 X 4 3/4 X 12 5/8	37
35	1 1/2" 600 X 2" 150	H	741-850	4 7/8 X 4 3/4 X 12 5/8	38
55	1 1/2" 150 X 3" 150	G*	15-285	4 7/8 X 4 3/4 X 10 1/2	27
56	1 1/2" 300 X 3" 150	G*	286-740	4 7/8 X 6 X 10 1/2	32
74	1 1/2" 600 X 3" 150	G*	741-1480	4 7/8 X 6 X 10 1/2	33
75	1 1/2" 900 X 3" 300	F*,G*	1481-2220	4 7/8 X 6 1/2 X 10 1/2	44
94	1 1/2" 1500 X 3" 300	F*	2221-2400	4 7/8 X 6 1/2 X 10 1/2	44
55	1 1/2" 150 X 3" 150	H*	15-285	5 1/8 X 4 7/8 X 12 7/8	38
56	1 1/2" 300 X 3" 150	H*	286-740	5 1/8 X 4 7/8 X 12 7/8	42
42	2" 150 X 2" 150	G	15-285	4 7/8 X 4 3/4 X 10 1/2	24
43	2" 300 X 2" 150	G	286-740	4 7/8 X 4 3/4 X 10 1/2	26
44	2" 600 X 2" 150	G	741-1480	5 3/8 X 6 X 11	29
45	2" 900 X 2" 300	G	1481-2000	6 1/16 X 6 X 11 11/16	46
42	2" 150 X 2" 150	H	15-285	4 7/8 X 4 3/4 X 12 5/8	36
43	2" 300 X 2" 150	H	286-740	4 7/8 X 4 3/4 X 12 5/8	39
44	2" 600 X 2" 150	H	741-850	4 7/8 X 6 X 12 5/8	40

NOTE: Mercer Valve reserves the right to change product designs and specifications without notice.

INLET-OUTLET CODE	VALVE SIZE AND FLANGE RATING INLET X OUTLET	AVAILABLE ORIFICE SIZE	PRESSURE RANGE (psig) C.S. @100° F	CENTER TO FACE DIMENSIONS (IN.) +/- 1/16 INLET X OUTLET X HT. "A" X "B" X "C"	APPROX. WEIGHT (lbs.)
46	2" 150 X 2 1/2" 150	H	15-285	4 7/8 X 4 3/4 X 12 5/8	39
47	2" 300 X 2 1/2" 150	H	286-740	4 7/8 X 4 3/4 X 12 5/8	41
48	2" 600 X 2 1/2" 150	H	741-850	4 7/8 X 6 X 12 5/8	43
48	2" 600 X 2 1/2" 150	H	851-1480	4 7/8 X 6 X 15 3/16	48
89	2" 900 X 2 1/2" 150	H	1481-2000	6 1/16 X 6 X 16 3/8	60
51	2" 150 X 3" 150	G	15-285	4 7/8 X 5 3/8 X 10 1/2	30
52	2" 300 X 3" 150	G	286-740	4 7/8 X 5 3/8 X 10 1/2	33
53	2" 600 X 3" 150	G	741-1480	6 1/16 X 6 3/8 X 11 11/16	37
54	2" 900 X 3" 300	G	1481-2000	6 1/16 X 6 3/8 X 11 11/16	56
52	2" 300 X 3" 150	H*	286-740	5 1/8 X 4 7/8 X 12 7/8	38
53	2" 600 X 3" 150	H*	741-850	6 1/16 X 6 3/8 X 13 13/16	40
53	2" 600 X 3" 150	H*	851-1480	6 1/16 X 6 3/8 X 16 3/8	45
91	2" 900 X 3" 150	H*	1481-2000	6 1/16 X 6 3/8 X 16 3/8	58
51	2" 150 X 3" 150	J*	15-285	5 3/8 X 4 7/8 X 13 3/8	52
52	2" 300 X 3" 150	J*	285-450	5 3/8 X 4 7/8 X 13 3/8	55
52	2" 300 X 3" 150	J*	451-740	5 3/8 X 4 7/8 X 17 1/16	65
62	3" 150 X 4" 150	K*	15-285	6 1/8 X 6 3/8 X 14 3/16	76
84	3" 300 X 4" 150	J*	286-450	7 1/4 X 7 1/8 X 15 1/4	83
84	3" 300 X 4" 150	J*	451-740	7 1/4 X 7 1/8 X 19	94
64	3" 300 X 4" 150	K*	286-740	6 1/8 X 6 3/8 X 17 7/8	91
85	3" 600 X 4" 150	J*,K*	740- 1480	7 1/4 X 7 1/8 X 19	96
86	3" 900 X 4" 150	J*	1481-1800	7 1/4 X 7 1/8 X 19	107
67	3" 150 X 4" 150	L*	15-285	6 1/8 X 6 1/2 X 15 3/4	97
68	3" 300 X 4" 150	L*	15-285	6 1/8 X 6 1/2 X 15 3/4	100
71	4" 300 X 6" 150	L*	286-300	7 1/16 X 7 1/8 X 17 1/4	140
71	4" 300 X 6" 150	L*	301-600	7 1/16 X 7 1/8 X 20 3/16	160
71	4" 300 X 6" 150	L*	601-740	7 1/16 X 7 1/8 X 24 13/16	180
72	4" 600 X 6" 150	L*	741-1250	7 1/16 X 8 X 24 5/8	195
70	4" 150 X 6" 150	M*	15-250	7 X 7 1/4 X 17 3/16	135
70	4" 150 X 6" 150	M*	251-285	7 X 7 1/4 X 20 1/8	150
71	4" 300 X 6" 150	M*	286-500	7 X 7 1/4 X 20 1/8	160
71	4" 300 X 6" 150	M*	501-740	7 X 7 1/4 X 24 3/4	180
72	4" 600 X 6" 150	M*	741-1000	7 X 8 X 24 3/4	195

NOTES: (1) * Indicates API Flange Size and Dimensions. (2) Consult factory for other size options. (3) Pressure Limit, Weight, & "C" dimension may vary with sour gas options.

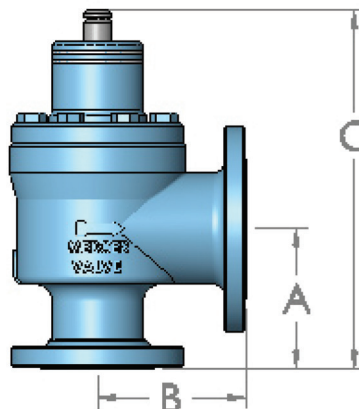

NOTE: Mercer Valve reserves the right to change product designs and specifications without notice.



FLANGE RATINGS

ASME B16.5-2003**ANNEX F****Tables F2-1.1 & F2-2.2 Pressure-Temperature Ratings for Group 1.1 & 2.2 Materials**

	Forging	Castings
Carbon Steel	A105	A216 Gr. WCB
Stainless Steel	A182 Gr. F316	A351 Gr. CF3M

Working Pressures by Classes, psig

Temp. Range (°F)		Material	150lb	300lb	600lb	900lb	1500lb	2500lb
Min	Max							
-20	100	Carbon Steel	285	740	1480	2220	3705	6170
		Stainless Steel	275	720	1440	2160	3600	6000
101	200	Carbon Steel	260	680	1360	2035	3395	5655
		Stainless Steel	235	620	1240	1860	3095	5160
201	300	Carbon Steel	230	655	1310	1965	3270	5450
		Stainless Steel	215	560	1120	1680	2795	4660
301	400	Carbon Steel	200	635	1265	1900	3170	5280
		Stainless Steel	195	515	1025	1540	2570	4280
401	500	Carbon Steel	170	605	1205	1810	3015	5025
		Stainless Steel	170	480	955	1435	2390	3980
501	600	Carbon Steel	140	570	1135	1705	2840	4730
		Stainless Steel	140	450	900	1355	2255	3760



9100 Series Flanged Capacity Charts

CAPACITY IN SCFM OF AIR AT 60°F AND STD ATMOSPHERIC CONDITIONS

Set Pressure (psi)	C 0.062	D 0.122	E 0.212	F 0.337	G 0.472	H 0.865	J 1.43	K 2.074	L 3.205	M 4.08
15	30	60	104	165	231	424	701	1017	1572	2001
20	35	69	120	191	267	489	808	1172	1812	2306
25	40	78	136	216	302	554	916	1328	2052	2612
30	44	87	152	241	338	619	1023	1483	2292	2918
50	65	128	222	352	493	904	1495	2168	3350	4264
75	90	178	309	491	688	1261	2084	3023	4671	5947
100	116	228	396	630	883	1617	2674	3878	5993	7629
125	141	278	484	769	1077	1974	3264	4733	7314	9311
150	167	329	571	908	1272	2331	3853	5589	8636	10994
200	218	429	746	1186	1661	3044	5033	7299	11279	14359
300	320	631	1096	1742	2440	4471	7391	10720	16566	21088
400	423	832	1445	2298	3218	5898	9750	14141	21852	27818
500	525	1033	1795	2854	3997	7324	12109	17562	27138	34548
600	627	1234	2145	3409	4775	8751	14467	20983	32425	41277
700	730	1435	2494	3965	5554	10178	16826	24403	37711	48007
800	832	1637	2844	4521	6332	11605	19185	27824	42998	54737
900	934	1838	3194	5077	7111	13031	21543	31245	48284	61466
1000	1036	2039	3544	5633	7889	14458	23902	34666	53570	68196
1200	1241	2442	4243	6745	9446	17312	28619	41508	64143	
1500	1548	3045	5292	8412	11782	21592	35695	51771		
1800	1854	3649	6341	10080	14118	25872	42771			
2000	2059	4051	7040	11191	15675	28726				
2400	2468	4856	8439	13415						
2600	2673	5259								
2800	2877	5661								
2999	3081	6062								

**CAPACITY IN SCFM OF 0.6 SG NATURAL GAS AT 60°F AND STD ATMOSPHERIC CONDITIONS**

Set Pressure (psi)	C 0.062	D 0.122	E 0.212	F 0.337	G 0.472	H 0.865	J 1.43	K 2.074	L 3.205	M 4.08
15	38	75	130	206	289	529	875	1269	1960	2496
20	44	86	150	238	333	610	1008	1463	2260	2877
25	50	97	169	269	377	691	1142	1657	2560	3259
30	55	109	189	301	421	772	1276	1851	2860	3640
50	81	159	276	439	615	1128	1864	2704	4179	5319
75	113	222	385	613	858	1573	2600	3771	5827	7418
100	145	285	495	786	1101	2018	3336	4838	7476	9517
125	177	347	604	959	1344	2463	4071	5905	9125	11616
150	208	410	713	1133	1587	2908	4807	6972	10773	13715
200	272	536	931	1480	2072	3798	6278	9105	14071	17912
300	400	787	1367	2173	3043	5577	9220	13373	20665	26307
400	527	1038	1803	2866	4015	7357	12163	17640	27260	34702
500	655	1289	2239	3560	4986	9137	15105	21908	33855	43097
600	782	1540	2676	4253	5957	10917	18048	26175	40449	51492
700	910	1791	3112	4947	6928	12697	20990	30443	47044	59887
800	1038	2042	3548	5640	7899	14477	23932	34710	53639	68283
900	1165	2293	3984	6333	8871	16256	26875	38978	60233	76678
1000	1293	2544	4420	7027	9842	18036	29817	43245	66828	85073
1200	1548	3046	5293	8414	11784	21596	35702	51780	80017	
1500	1931	3799	6602	10494	14698	26935	44529	64583		
1800	2313	4552	7910	12574	17611	32275	53356			
2000	2568	5054	8783	13961	19554	35835				
2400	3079	6058	10527	16735						
2600	3334	6560								
2800	3589	7062								
2999	3843	7562								



CAPACITY IN GPM WATER AT 60°F AND STD ATMOSPHERIC CONDITIONS

Set Pressure (psi)	C 0.062	D 0.122	E 0.212	F 0.337	G 0.472	H 0.865	J 1.43	K 2.074	L 3.205	M 4.08
15	7	14	24	38	54	99	163	236	365	465
20	8	16	27	43	61	111	184	267	413	526
25	9	17	30	48	67	123	203	295	456	580
30	10	19	33	52	73	133	221	320	495	630
50	12	24	42	67	94	172	285	413	639	813
75	15	30	52	82	115	211	349	506	782	996
100	17	34	60	95	133	244	403	584	903	1150
125	20	38	67	106	149	272	450	653	1010	1285
150	21	42	73	116	163	299	493	716	1106	1408
200	25	49	84	134	188	345	570	826	1277	1626
300	30	60	103	164	230	422	698	1012	1564	1991
400	35	69	119	190	266	487	806	1169	1806	2299
500	39	77	134	212	297	545	901	1307	2019	2571
600	43	84	146	233	326	597	987	1431	2212	2816
700	46	91	158	251	352	645	1066	1546	2389	3042
800	49	97	169	269	376	689	1140	1653	2554	3252
900	52	103	179	285	399	731	1209	1753	2709	3449
1000	55	109	189	300	421	771	1274	1848	2856	3635
1200	61	119	207	329	461	844	1396	2024	3128	
1500	68	133	231	368	515	944	1561	2263		
1800	74	146	253	403	564	1034	1709			
2000	78	154	267	425	595	1090				
2400	86	168	293	465						
2600	89	175								
2800	92	182								
2999	96	188								



9100 Series Flanged Product Numbering System

91 - 17 D 1 1

VALVE SERIES

91 – 9100 Series

INLET & OUTLET COMBINATION

(See Selection Table pages 8 & 9)

ORIFICE SIZE

C to M

INLET BASE & BODY MATERIAL

- 1 – RF x RF / CARBON STEEL
- 2 – RF x RF / STAINLESS STEEL
- 3 – RTJ x RF / CARBON STEEL
- 4 – RTJ x RF / STAINLESS STEEL
- A – RTJ x RTJ / CARBON STEEL
- B – RTJ x RTJ / STAINLESS STEEL

CAP TYPE

- 1 – CLOSED CAP
- 2 – OPEN LIFT LEVER
- 3 – CLOSED LIFT LEVER
- 4 – CLOSED CAP W/STAINLESS STEEL BONNET (H - M ORIFICE)
- 5 – OPEN LIFT LEVER W/STAINLESS STEEL BONNET (H - M ORIFICE)
- 6 – CLOSED LIFT LEVER W/STAINLESS STEEL BONNET (H - M ORIFICE)

CONSULT FACTORY FOR
ADDITIONAL INFORMATION
AND OPTIONS

NOTE: Mercer Valve reserves the right to change product designs and specifications without notice.



2 - DIGIT "SPECIAL" CODE
(IF APPLICABLE ASSIGNED BY MERCER)

O-RING MATERIAL

1 - STANDARD O-RINGS
(FLUOROCARBON (FKM) & BUNA-N)

TRIM CODES

U - 316 S.S. DISK & NOZZLE (STD GAS SERVICE F,G,H,J,K,L, & M ORIFICES)*

I - 17-4 S.S. DISK & NOZZLE (STD GAS SERVICE D&E ORIFICES)

C - 440C S.S. DISK, 17-4 S.S. NOZZLE (STD GAS SERVICE C ORIFICE AND HIGH PRESSURE F,G,H,J,K & L)*

L - LIQUID SERVICE 316 S.S. DISK & NOZZLE

N - SOUR GAS SERVICE 316 S.S. DISK & NOZZLE

B - SOUR LIQUID SERVICE 316 S.S. DISK & NOZZLE

SPRING CODE
(ASSIGNED BY MERCER)

SEAT MATERIAL

V - FLUOROCARBON (FKM) 90 DURO

T - 15% GLASS FILLED PTFE

P - VIRGIN PEEK

* = U TRIM CODE CHANGES TO C TRIM CODE AT
F > 1399psi, G > 1199psi, H > 1049psi
J > 1124psi, K > 799psi, L > 599psi



CORPORATE HEADQUARTERS

9609 NW 4th STREET
OKLAHOMA CITY, OK 73127
1-800-833-6402
PHONE: (405) 495-6533, FAX: (405) 495-8728

SALES@MERCERVALVE.NET

Please visit our website to learn about our branch locations!

WWW.MERCERVALVE.NET

Mercer Valve Company, Inc.® manufactures pressure relief valves for uses with many different products. Your choice of a valve requires that you, as buyer, determine the valve material is compatible with the intended use of the valve. You are responsible to insure that the correct pressure relief valve is installed for your application and your order of a valve confirms the material compatibility choices.