

9600FL SERIES PANIC BOLT

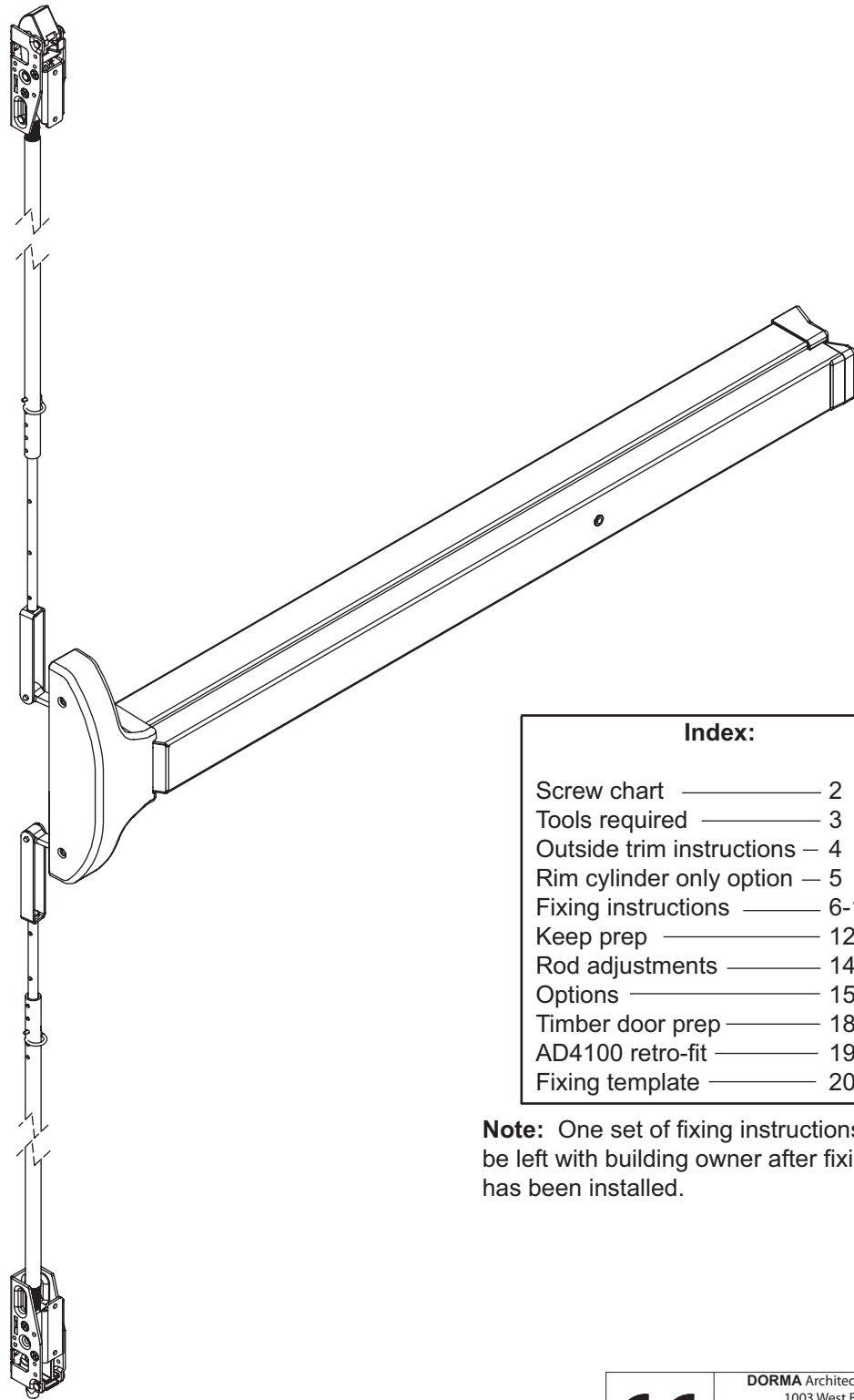

Index:

Screw chart	2
Tools required	3
Outside trim instructions	4
Rim cylinder only option	5
Fixing instructions	6-11
Keep prep	12-13
Rod adjustments	14
Options	15-17
Timber door prep	18
AD4100 retro-fit	19
Fixing template	20

Note: One set of fixing instructions should be left with building owner after fixing of device has been installed.

EN 1125 CLASSIFICATION NUMBER FOR THIS PRODUCT

3	7	6	0	1	3	2	2	B	A
---	---	---	---	---	---	---	---	---	---

CE	DORMA Architectural Hardware
	1003 West Broadway
	Steeleville, IL 62288
	BS EN 1125-2008
9600FL AAA040	European Norm Standard for Panic
2011	Exit Devices Operated By A Horizontal Bar.
	Product Classification 3,7,6,0,1,3,2,2,B,A
	Certification Body Ref Nr : 1121

SCREW CHART

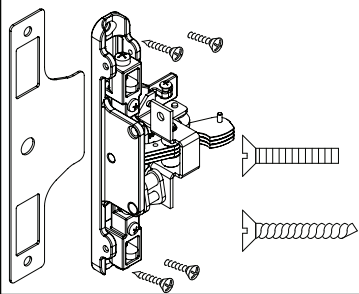

- (2) M5 x 20 F.H.P.M.S. (Metal door metric version) _____ Chassis Mounting
- (2) 12-24 x 1 1/4" F.H.P.M.S. (Trim or Thru Bolts) _____ Chassis Mounting
- (2) #12 x 1 1/4" R.H.P.T.S. (Timber Door) _____ Chassis Mounting

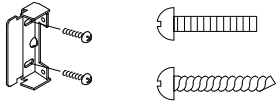

- (2) M5 x 20 R.H.P.M.S. (Metal door metric version) _____ End Cap Bracket
- (2) 12-24 x 1" R.H.P.M.S. (Trim or Thru Bolts) _____ End Cap Bracket
- (2) #12 x 1 1/4" R.H.P.T.S. (Timber Door) _____ End Cap Bracket

Optional "WD" mounting brackets (4)
(wood, steel)

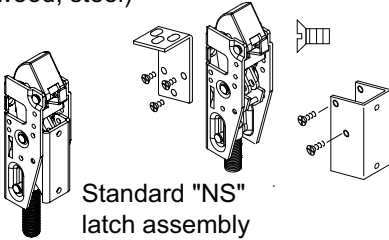

Standard "NS"
latch assembly

- (12) 8-32 x 6mm F.H.P.M.S. _____ Bracket to latch
- Optional: "ALD" Mounting Bracket (2) (8) 8-32 x 6mm F.H.P.M.S. _____ Bracket to latch
(Medium Stile Aluminum Doors)
- (4) 10-32 x 6mm F.H.P.M.S. (Aluminum) _____ Bracket to door

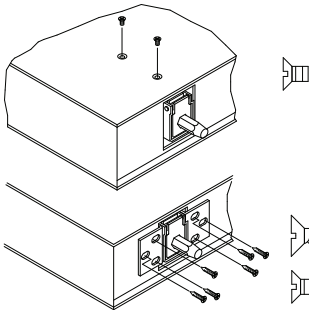

- (4) 10-32 x 6mm F.H.P.M.S. (Aluminum) _____ Bracket to door
- (12) #10 x 25mm F.H.P.T.S. (Timber door) _____ Bracket to door
- (12) M5 x 10mm F.H.P.M.S. (Metal door metric version) _____ Bracket to door

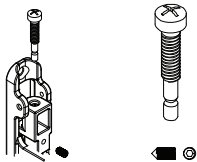

- _____ Adjusting screw
- (2) 3/32 x 10-32 x 13mm Allen Head (wrench supplied) _____ Locking screw



- (2) Rod retaining clips _____ Rod installation



- (2) M5 x 10mm F.H.P.M.S. _____ #AD418 Keep pack

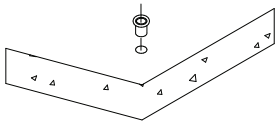

#AD439 Bottom
keep pack
(cement or grout
in place)

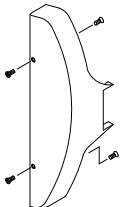

- (4) 8-32 x 6mm F.H.P.M.S. _____ Chassis cover
& end cap

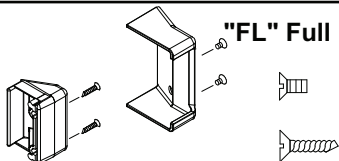

"FL" Full length touch bar & rail series.

- (2) 8-32 x 6mm F.H.P.M.S. _____ End Cap Mounting
- (2) #10 x 25mm F.H.P.T.S. _____ End Cover Mounting

HANDING OF DOOR

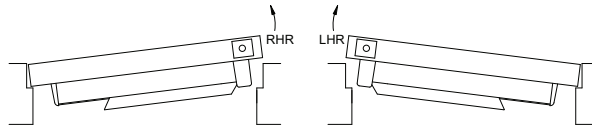
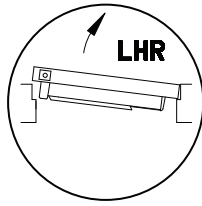
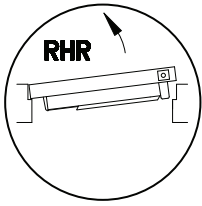

Read the entire instruction sheet prior to installation.
Before Installing Hardware:

1. Verify door width, handing and product with carton label for correct exit device and length. (See Step 9)
2. For hand reversal of chassis see page 7, for outside lever trim see page (4).
3. For less bottom rod device, delete bottom latch installation steps.
4. Device installation and preliminary adjustments should be made prior to hanging door.

Note: Less bottom rod device is not recommended where security is a primary concern.

Note: If device is to be installed over glass lite panels, shim kit may be required, order GK9200.

TYPICAL DEVICE FIXING

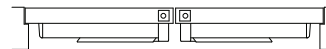
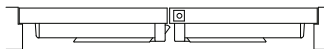
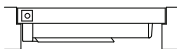
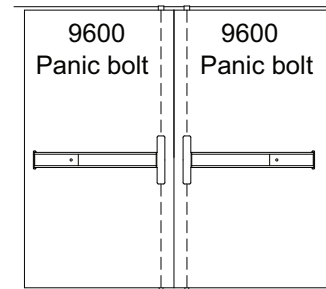
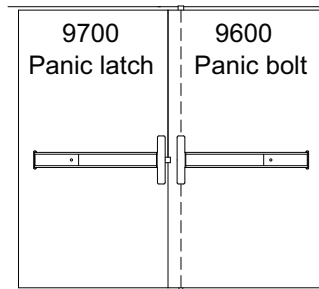
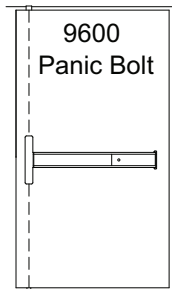

SPECIAL TOOLS FOR FIXING

Centre Punch
M5 - Tap, M6 - Tap
Drill bits: 3.8mm, 4.2mm, 10mm, 13mm, 25mm & 38mm
5/32" Allen wrench for lever trim.
Cross point screw driver
Hack saw
3/32" Allen wrench (supplied)
32mm hole saw

TYPICAL OUTSIDE TRIM INSTRUCTIONS

Note: When used with narrow stiles, consult door manufacturer for compatibility.



LHRB TRIM SHOWN RHRB OPPOSITE

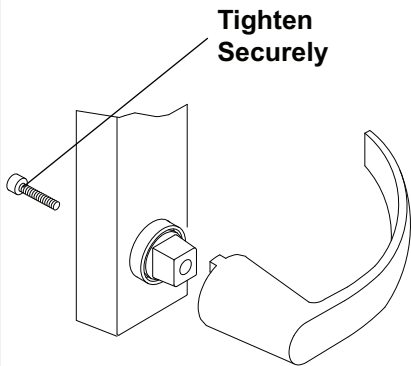
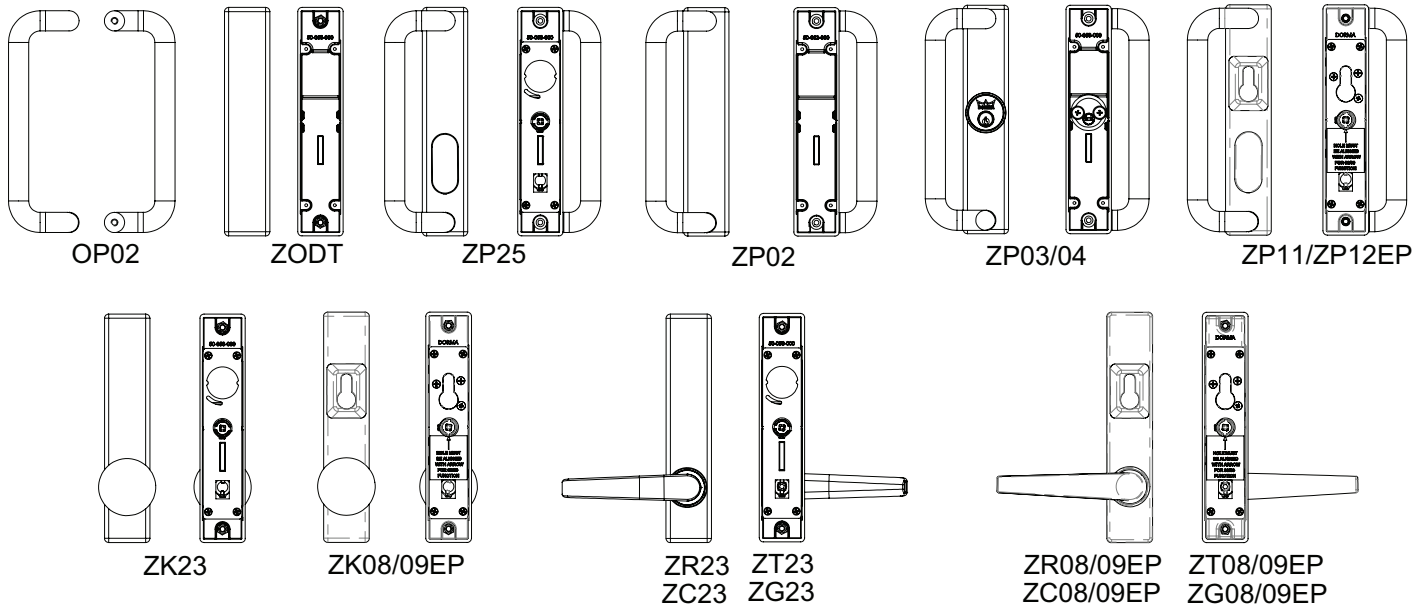

IMPORTANT

Note: All lever handles except for "clutch" are shipped unattached. To install; **Place handle in desired position and attach with allen screw located in back of trim plate. 5/32"** Allen wrench required.
To change hand on "clutch" trim rotate and "break" lever around to desired hand.

All trims are free wheeling.
(Handle will rotate when locked.)

Fixing of "EP" cylinder

Insert "EP" cylinder into adapter, secure with set screw supplied with cylinder. Insert adapter/cylinder assembly thru trim and secure assembly with (2) 8-32 screws as shown. For "09" function (key only removable when locked) insert additional 8-32 screw as shown.

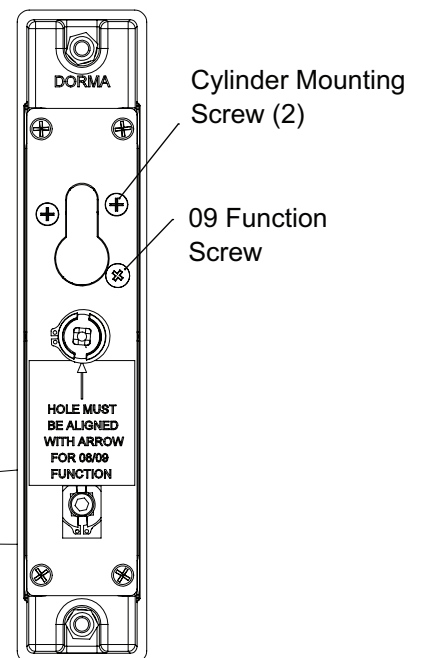
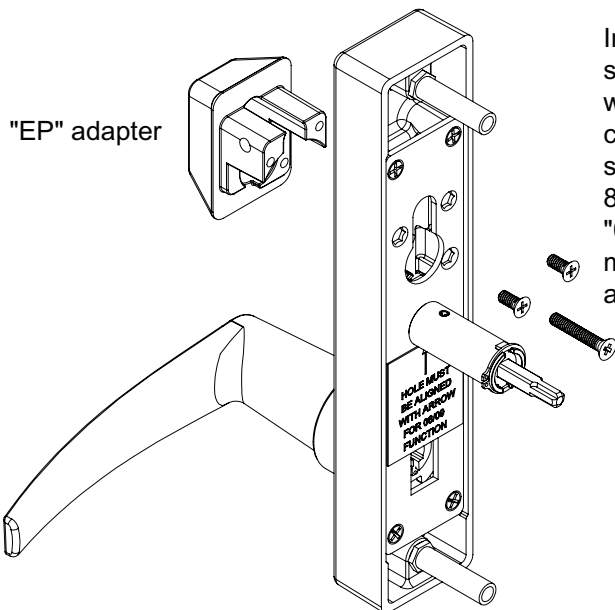

ADDITIONAL DOOR PREP REQUIREMENTS

9600FL

Rim Exit Device

RHR Shown

LHR Opposite

Required for "03" & "04" function on device
with cylinder only and no trim.
(NOT TO SCALE)

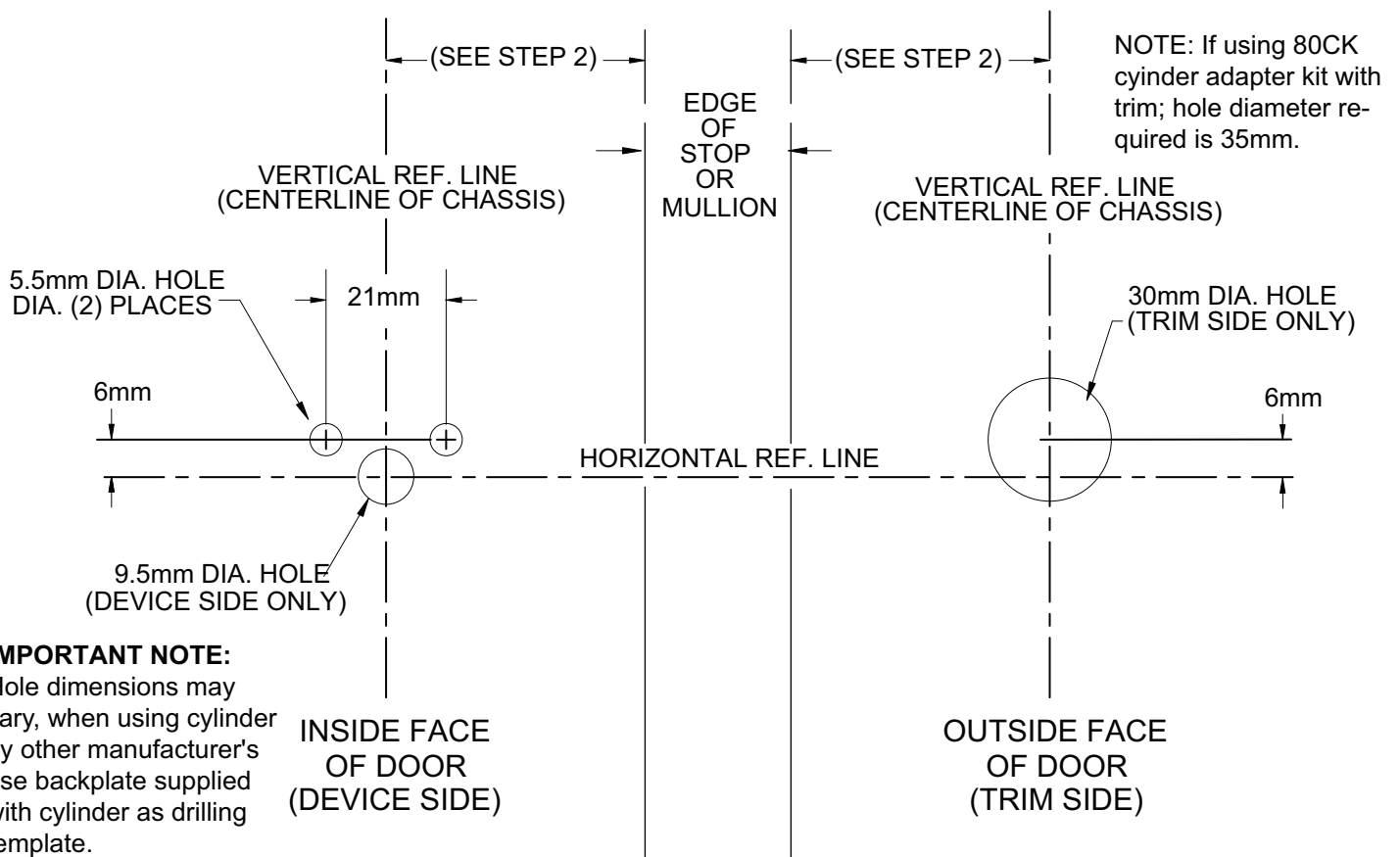

1 With door lying on saw horses, open box, layout all parts and verify prior to starting installation. See page (2) two for parts.

Note: If this is a retro-fit from current AD4100 see page 19 prior to proceeding.

2 Door preparation

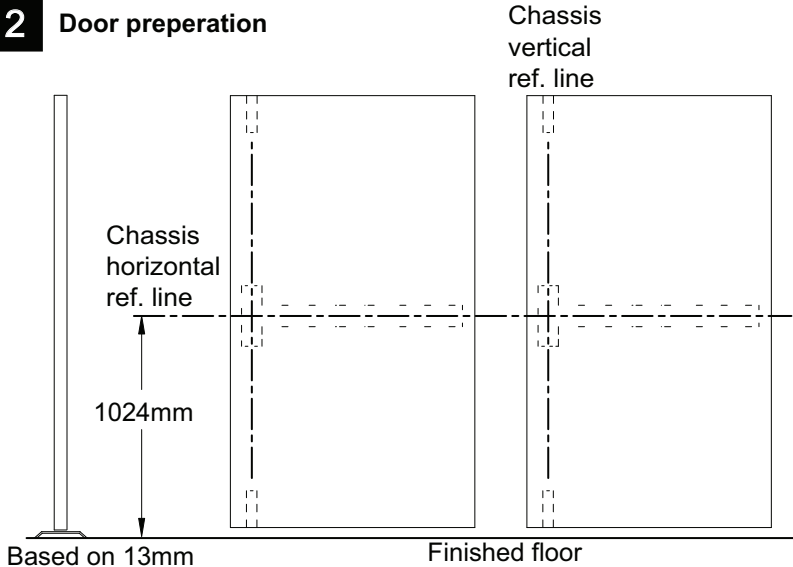

Based on 13mm threshold and 5mm clearance between threshold and door after door is hung.

Finished floor

Chassis template located at rear of booklet. Cut and tape in place. Lay out horizontal and vertical reference lines.

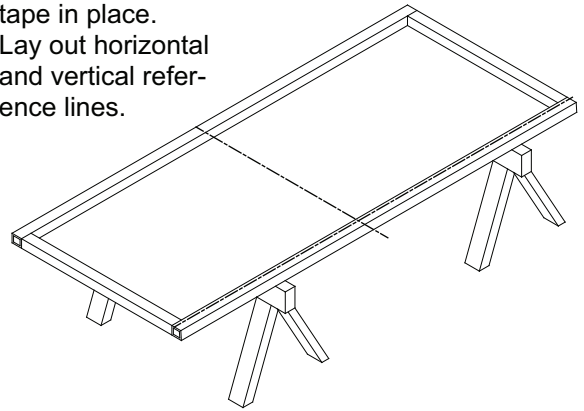

Backset or vertical reference is measured from outer edge of door as shown. Minimum stile is less glass stop.

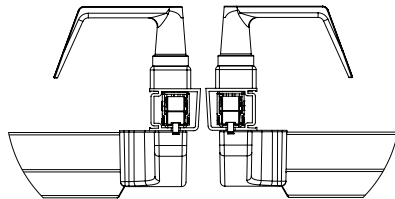
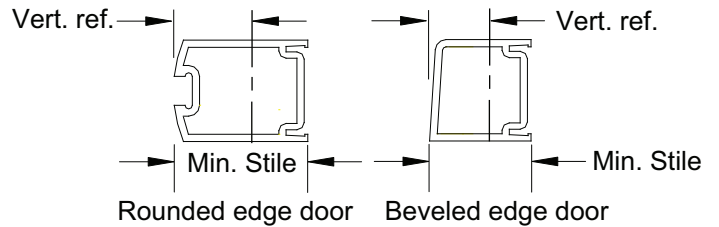

Typical pair of doors

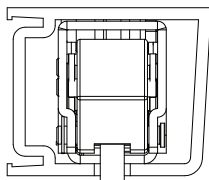

Note: On narrow stile, vertical center line of chassis may not be on same center line as latch.

Type of installation	Minimum vertical ref. of chassis	Minimum Stile	
		Pull only	"Z" trim
Single door 13mm blade stop	32mm	52mm	59mm
Pairs and double egress	32mm	51mm	54mm

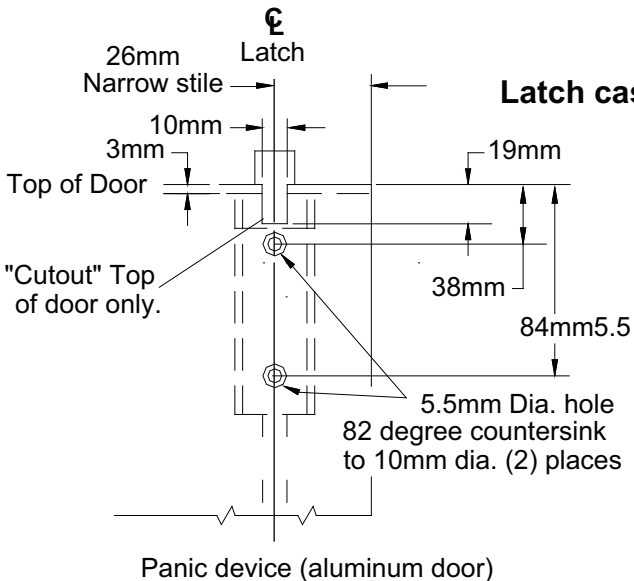

Panic device (aluminum door)

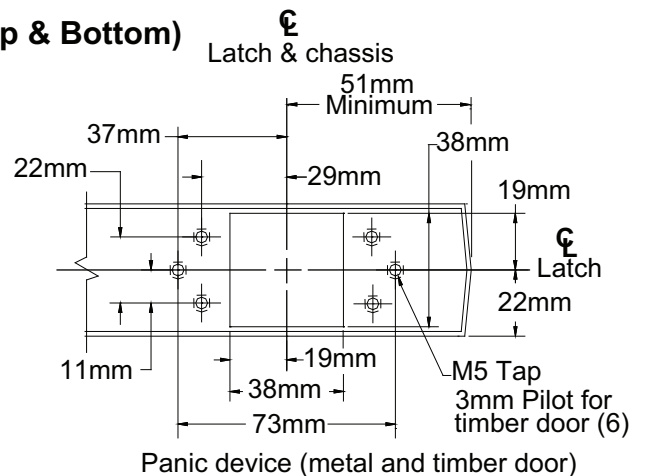

Panic device (metal and timber door)

3 If not done layout device on door using drilling template T9600 located at rear of booklet.
For additional templates contact DORMA at 1-800-523-8483 or www.dorma-usa.com

Refer to carton label for model and trim number prior to drilling.
Prepare mounting holes and cut-outs per template.

VERTICAL REF. LINE
(See Backsets on page 6.)

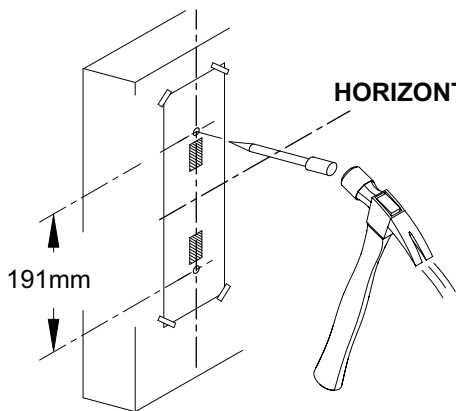

HORIZONTAL REF. LINE

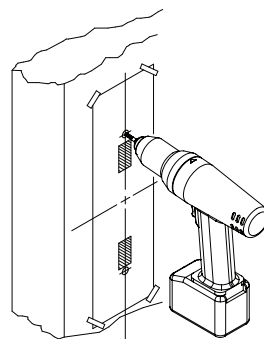

Verify all holes
prior to drilling.

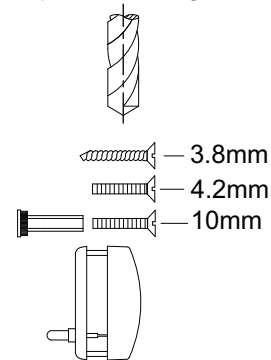

4 Hand reversal of chassis. Follow steps in alphabetical sequence.

DISASSEMBLE
RHR
(Right Hand Reverse)

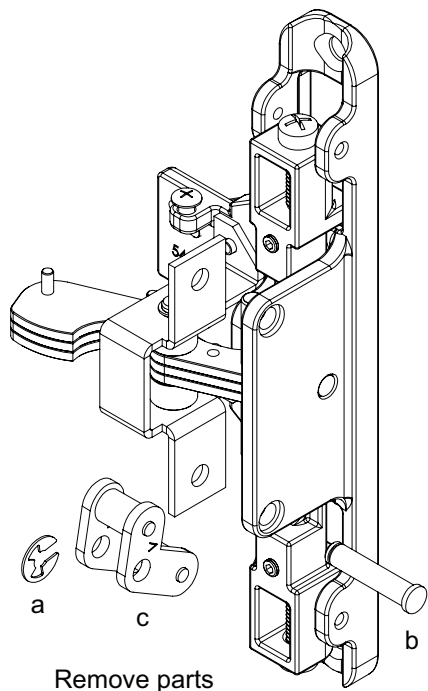

REASSEMBLE
LHR
(Left Hand Reverse)

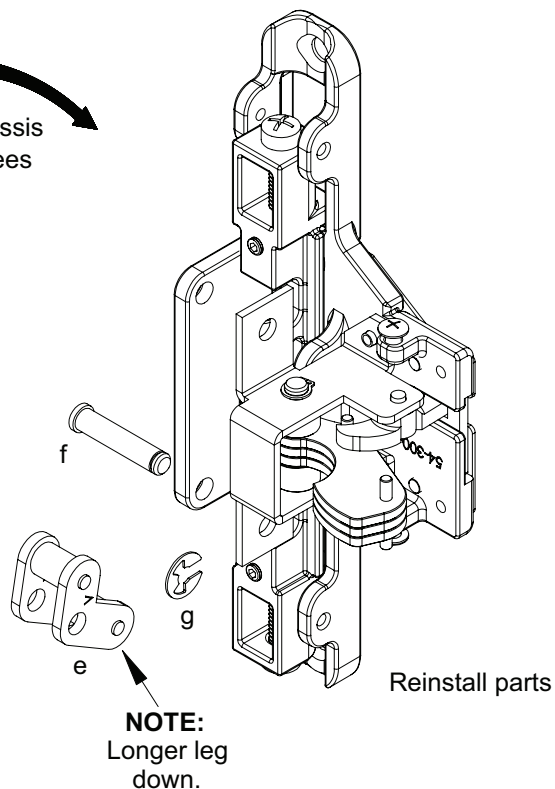

5 Assemble rods, latches and adjust to preliminary length.

Standard (NS) Narrow stile aluminum door mounting bracket (installed at factory).

Adjusting bolt

4th hole for top rod on 2134mm door opening.*

4th hole for top rod on 2134mm door opening.*

Thread on 16mm

Outer rod

13mm

Inner rod assembly

Top and bottom rods and latches are shipped unassembled and are adjustable for door opening heights ranging from 2032mm to 2438mm and will fit up to a 3048mm door opening with the addition of a 610mm top rod extension (ETR). Follow instructions on page to assemble the latch and rod assemblies. **"Standard" (NS) Narrow stile brackets are pre-assembled in the top and bottom latch cases.** Optional: Angle brackets are available for steel and wood door application, install as shown with proper fasteners.

Holes in outer rod are at 13mm intervals and holes in inner rod are at 51mm intervals for door openings under or over 2134mm (instructions are for 2134mm door opening and standard mounting height). **For all other door sizes, see rod adjustment chart.** Slide inner rod assemblies into outer rods, locate proper holes and insert rod retainer clip by; inserting through both rods, rotating it and locking it in place as shown. For "LBR" less bottom rod device skip bottom rod and latch assembly instructions.

Top latch & rod assembly.

Rod retaining clip.
51mm

Insert pin through proper holes, flip over and lock in place.



Optional: "ALD" bracket

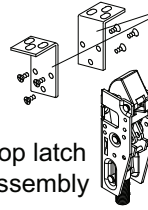

Optional: "WD" "L" shaped mounting brackets for steel and timber door.

Top latch assembly

Inner rod assembly

2nd hole from link on 2134mm door opening.*

Middle hole for bottom outer rod on 2134mm door opening.*

Insert pin through proper holes, flip over and lock in place.

"Use 4th hole using pullman latch".

Outer rod

Bottom latch & rod assembly.

Thread on leave approx. 3mm of thread showing.

Optional: "ALD" bracket



Optional: Pullman latch.



Thread on leave approx. 13mm of thread showing with pullman latch.

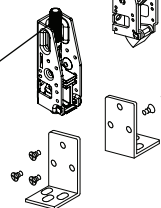

Optional: "WD" "L" shaped mounting brackets for steel and timber door applications.

6 Install rods in door and chassis as shown.

Pivot connecting links down as shown and slide latch assemblies into door.

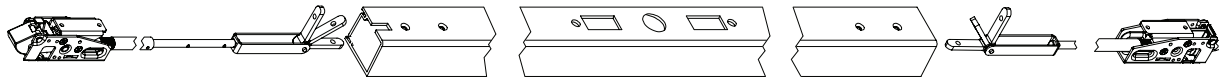

As linkages reach cut outs in door guide them through as shown;

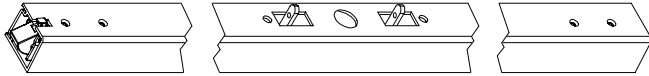

"Loosen only"; (2) two 3/32" Allen head locking screws using Allen wrench supplied, remove two adjusting screws shown.

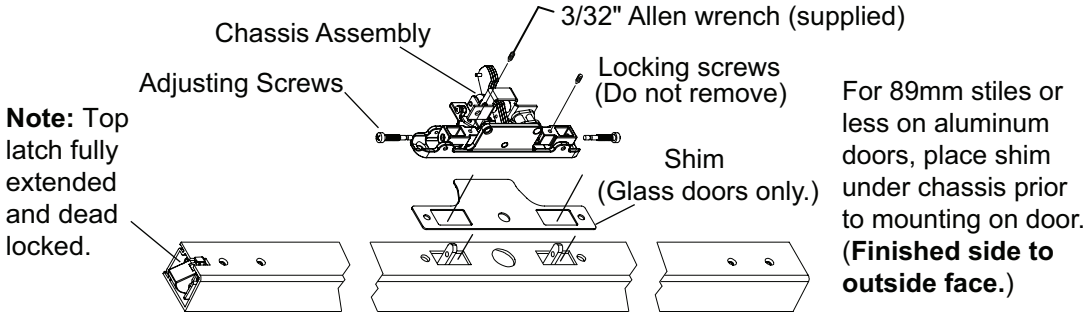

For 89mm stiles or less on aluminum doors, place shim under chassis prior to mounting on door. **(Finished side to outside face.)**

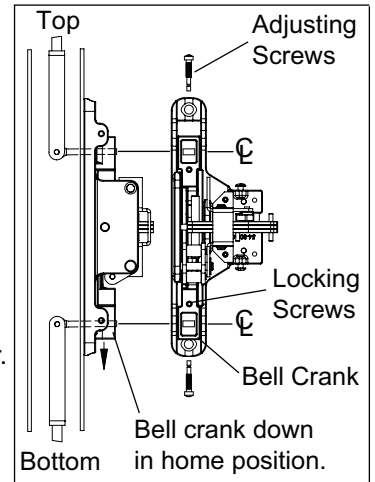

Place shim on door as shown (**polished side facing outside**) aligning holes and cut outs as required with holes and cut outs in door. Then place chassis on door allowing connecting links to extend through shim and into bellcrank of chassis as shown. **NOTE: Connecting link brackets should straddle mounting screws, shaft of thru-bolts, or stand-offs of trim as device is secured to door. See detail to right.**

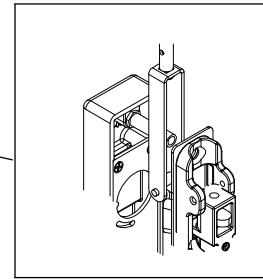

7 Secure chassis and latches to door as shown.

Note: Top latch fully extended and dead locked.

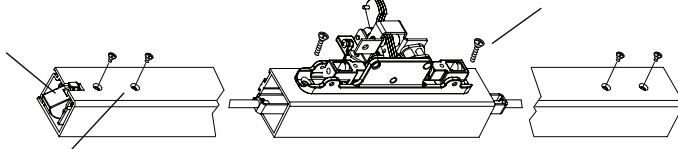

Metal - (2) 12-24 x 38mm F.H.P.M.S.
Timber - (2) #12 x 32mm F.H.P.T.S.
(For other options; trim, thru bolts, etc. see below.)

(4) 10-32 x 6mm F.H.P.H.M.S.
(Do not use any other screw.)

Optional mounting

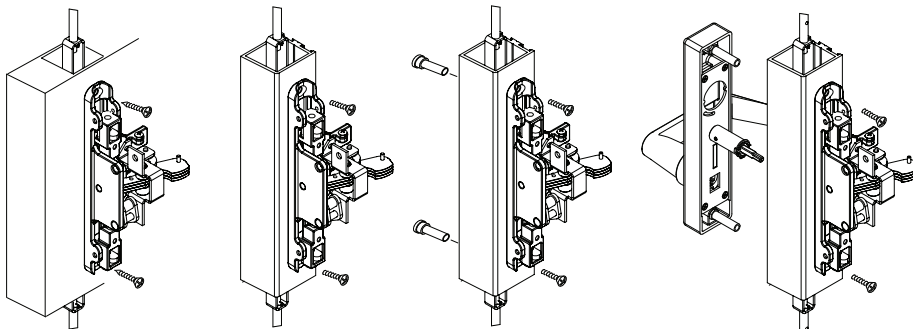

Optional: "WD"
(steel, timber applications).

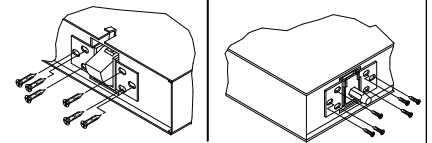

Attached "L" shaped mounting brackets to latch and install in door with proper fasteners as shown.

Steel - (6) 10-32 x 10mm F.H.P.M.S.
Timber - (6) #10 x 25mm F.H.P.T.S.

8 Install adjusting screws and connecting links to chassis.

Top latch bolt should be fully extended and dead locked. Bell crank should be in full down position (home position).

Connecting links should be about in center of cut out in bell crank.

Install top and bottom adjusting screws (b) through both bell crank and connecting link arms; bottom of adjusting screw head should bottom out on bell crank.

Tighten Allen head locking screws with (supplied) 3/32" Allen wrench.

Both top and bottom connecting links should be 90 degrees to chassis.

NOTE: If chassis is being installed with outside trim, ensure spindle of trim engages with cross hairs of cam located in rear of chassis.

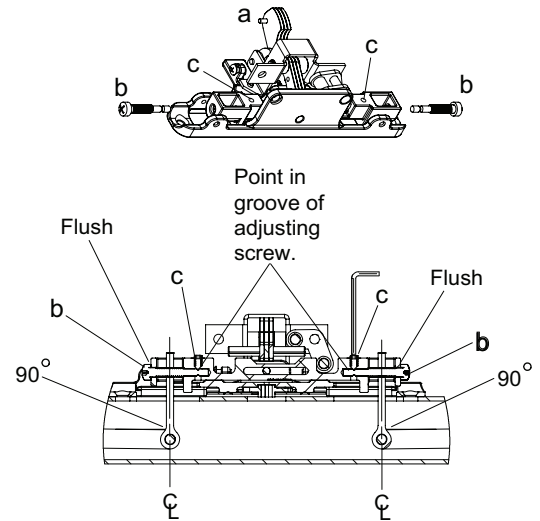
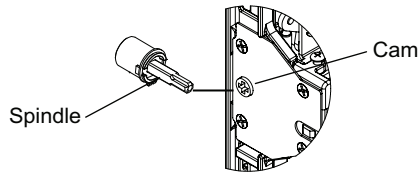

9 Prepare to install touch bar and rail on door.

NOTE: All dimensions are based on 13mm stop height; Verify strikes, stile width, any trim and stop height prior to making any cuts. If cutting is required follow instructions below.

Size AA:

Fits 1220mm door opening without cutting.

Can be cut to fit a 838mm minimum door opening.

Size BB:

Fits 915mm door opening without cutting.

Can be cut to fit a 686mm minimum door opening.

Size CC:

Fits 915 door opening with out cutting.

Using a shorter touch pad then the standard "BB" size allows it to be cut to 610 door opening.

Note: Models with prefix options such as "ES", "DE" etc. may not be cut down to minimums shown to left. Consult factory or catalog for details.

Verify device length with box label; "AA", "BB" or "CC", ie. 9600FL BB

Example:

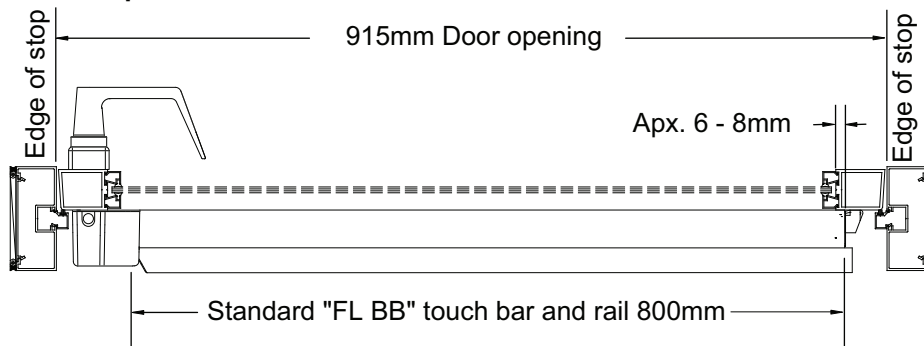

Note: If door opening width is less or stops are different, then standard touch bar will have to be cut down. ie: door opening width 863mm subtract 51mm from rear of rail, depress touch bar as shown, tape and cut to length as shown. Touch bar should be approximately 5mm longer then rail once it is released to upward position.

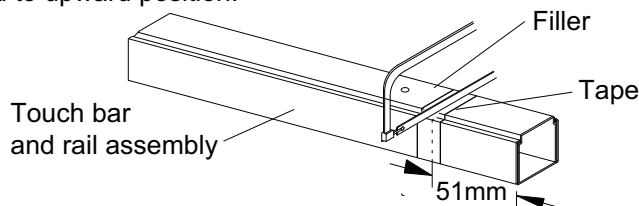

IMPORTANT

Use caution when cutting touchbar and rail to size on models with "ES", "MS", "LM" or "DWA" prefix options. These units contain internal wiring.

For models with prefix options "BPA", "BPAR" or "DE" remove filler containing electronics before cutting.

11 Install "FL" touch bar and rail assembly and end cap to door.

Remove two 8-32 screws from chassis, slide touch bar and rail assembly under rear of chassis. **Note: If device has prefix "ES" ensure that pins in lever bolt align with slots in actuator located inside nose of touch bar.** See instruction sheet IES-7 packed with device. Install (2) two 8-32 x 10mm P.H.P.M.S. to secure touchbar to chassis.

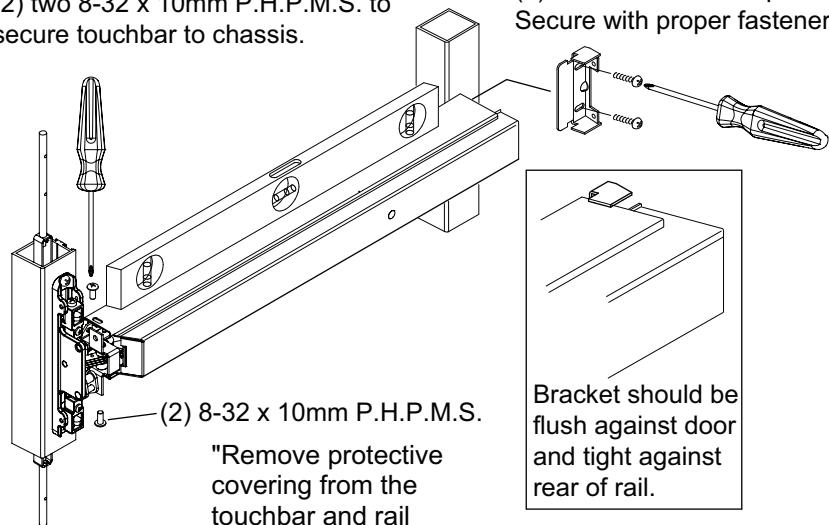

(2) 8-32 x 10mm P.H.P.M.S.

"Remove protective covering from the touchbar and rail assembly prior to installing on door."

Hold rear mounting bracket tightly against door and rear of rail. Mark (2) two holes and drill per chart. Secure with proper fasteners.

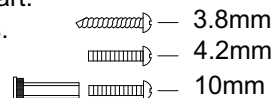

Metal/thru-bolts - (2) 12-24 x 25mm F.H.P.M.S.
Timber - (2) #12 x 32mm F.H.P.T.S.

For the following models prefixes: "ES", "MS", "LM" or "DWA" drill an additional 13mm diameter hole as shown. See options pages at rear for additional information.

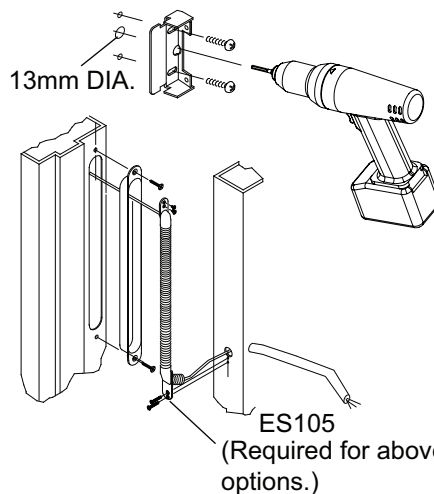

NOTE: If carton label list prefix; "ES", "MS", "LM", "BPA", "BPAR", "DWA", "LM/MS/BP" or "CD" prefix see Options pages at rear.

12 Install top keep in frame.

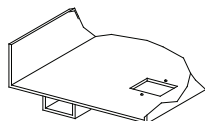

AD#418 Keep

(2) 10-32 x 10mm
F.H.P.M.S.

Optional:
AD#419 Keep (timber jamb) See **"Frame Preparation"** on page 12 for cut out and holes.



(2) #10 x 25mm
F.H.P.T.S.

13 Install bottom keep in floor or threshold.

See page 13 for additional mounting and optional keeps.

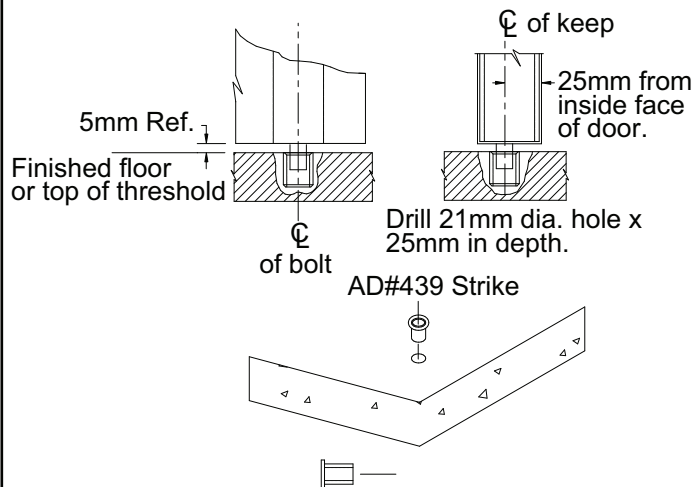

FRAME PREPARATION

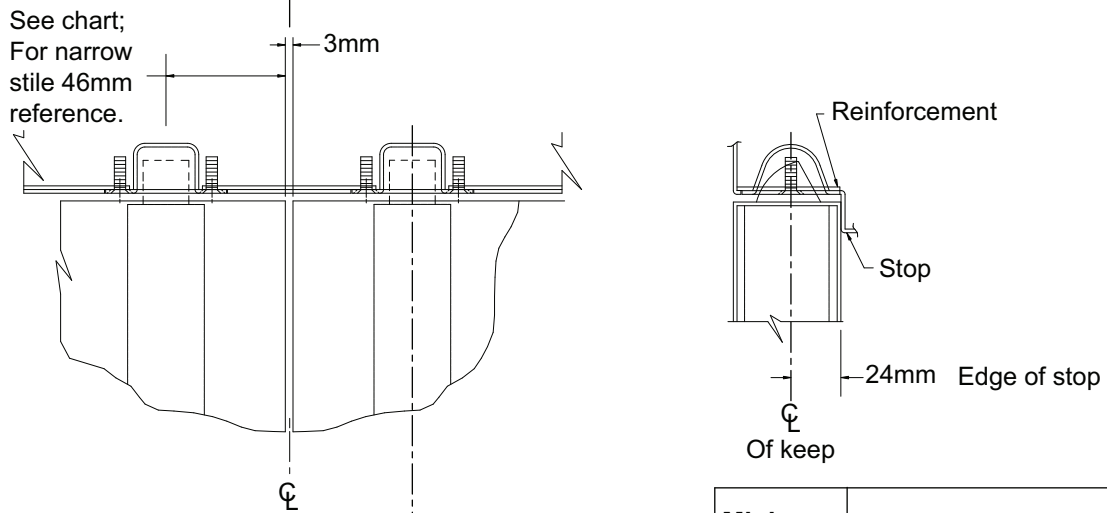
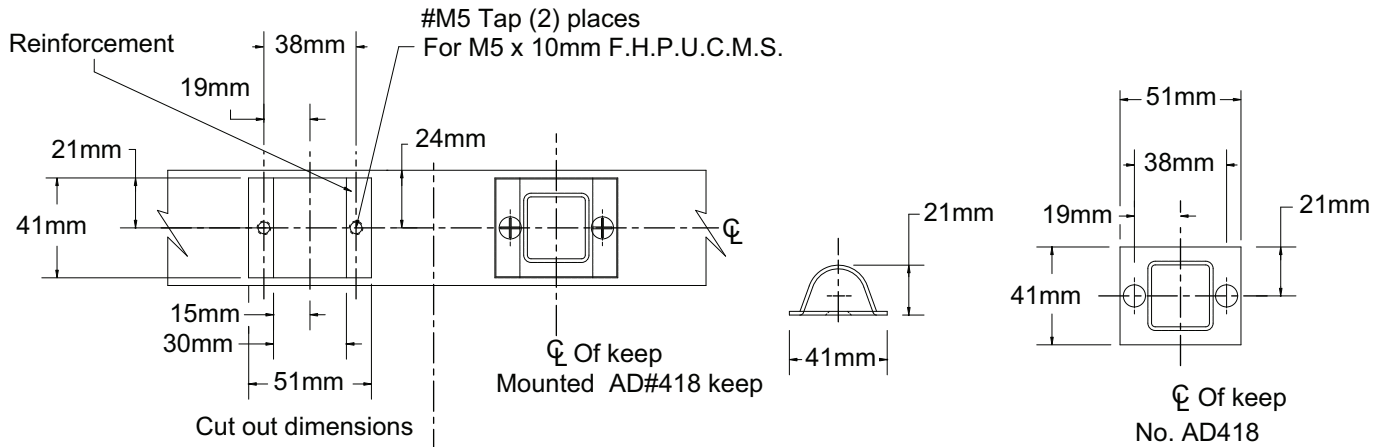

Note: On 51mm stile or less vertical center line of chassis is not on same center line as latch. Refer to page 6 details.

Type of installation	Minimum vertical ref. of chassis	Minimum Stile	
		Pull only	"Z" trim
Single door 13mm blade stop	32mm	52mm	59mm
Pairs and double egress	32mm	51mm	54mm

Optional prep for No. AD419 top keep in timber frame

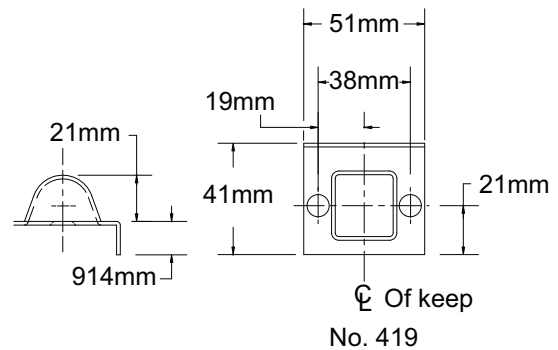
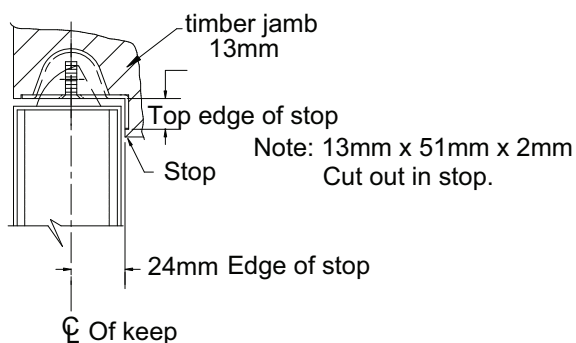

BOTTOM KEEP PREPARATION

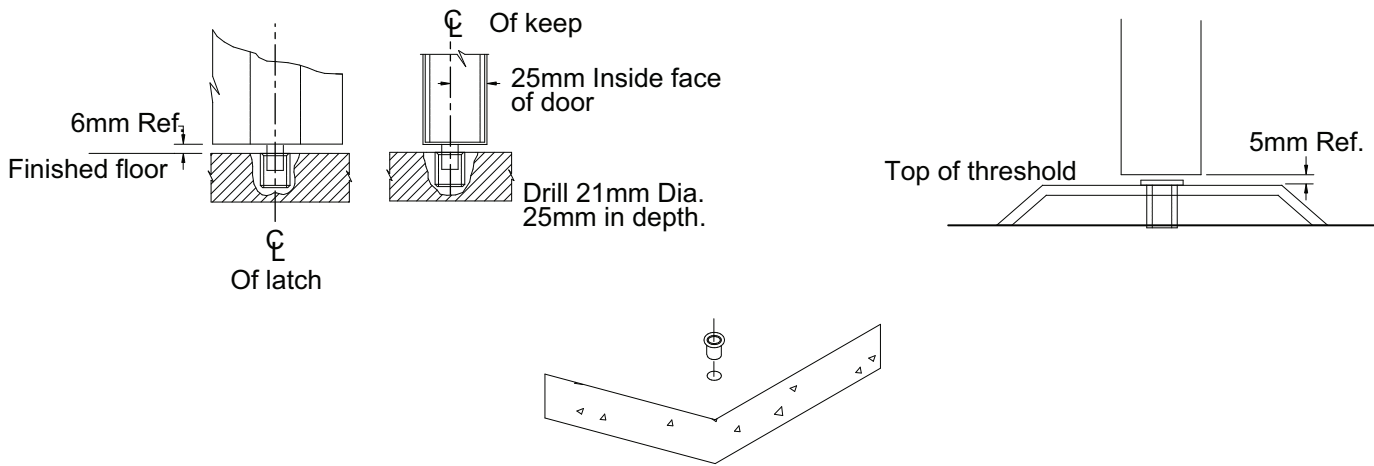

Optional pullman latch No. AD431 keep installation

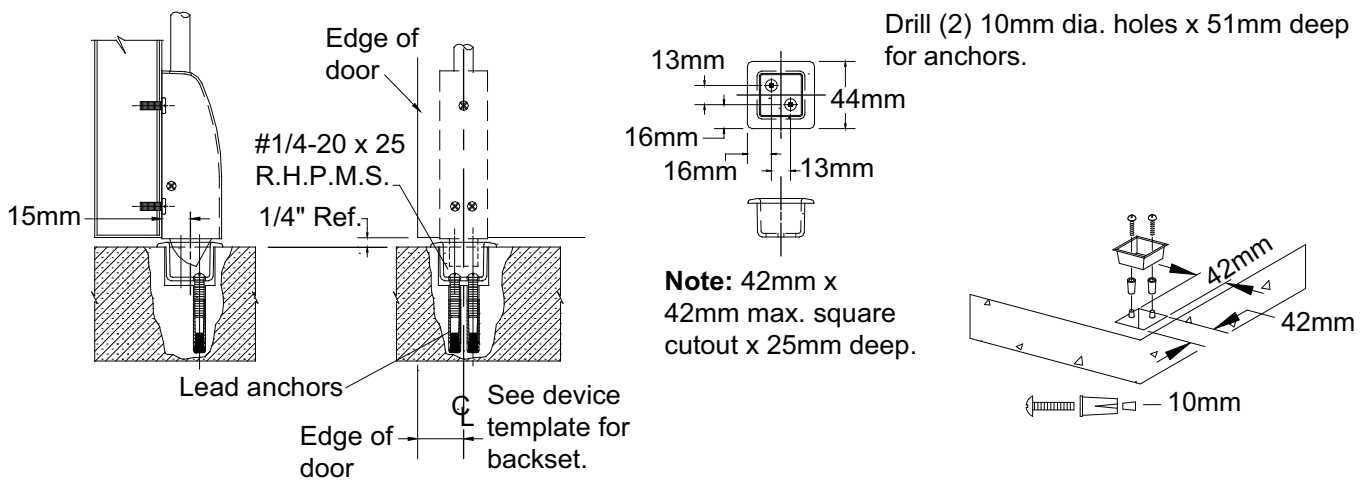

Optional slide bolt No. AD340 keep installation

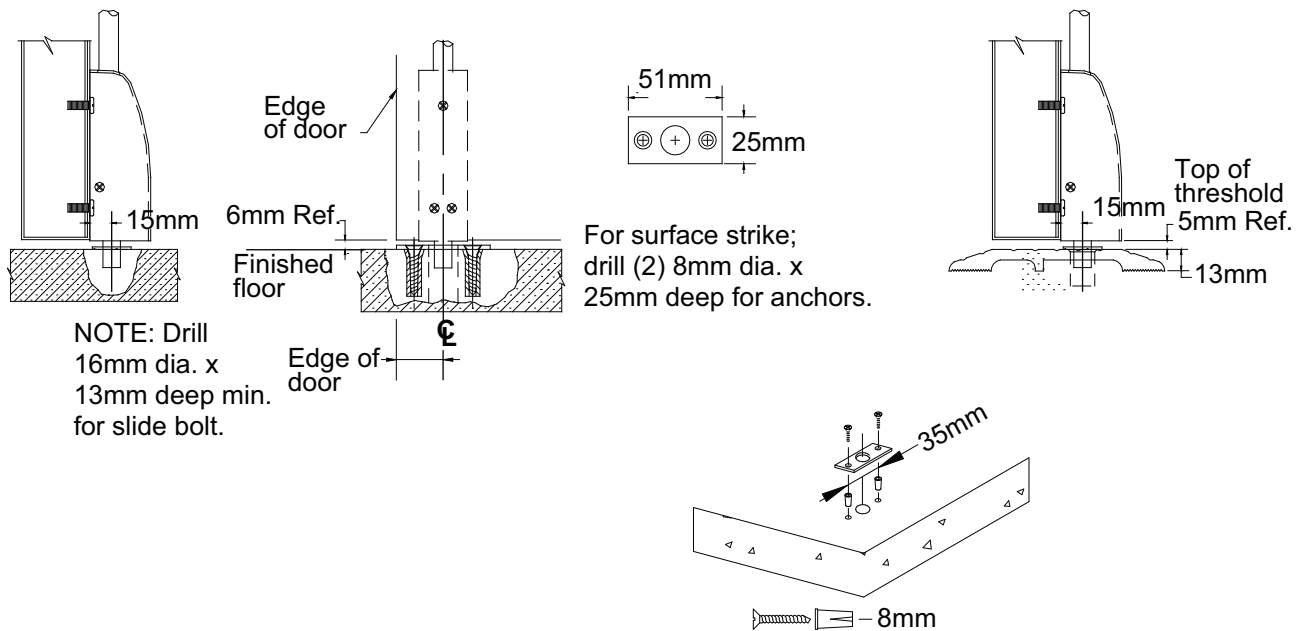

14 Adjustment of rods.

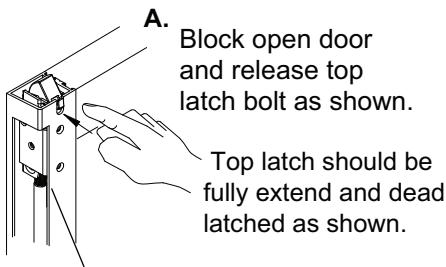

A. Block open door and release top latch bolt as shown. Top latch should be fully extend and dead latched as shown.

Note: "Cutouts" shown for clarity, not required.

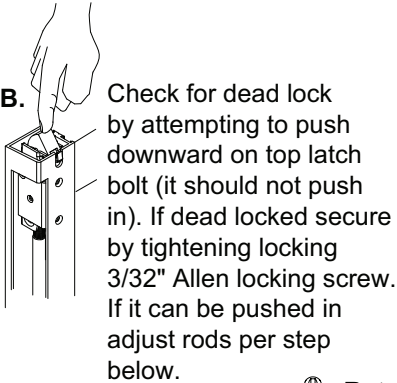

B. Check for dead lock by attempting to push downward on top latch bolt (it should not push in). If dead locked secure by tightening locking 3/32" Allen locking screw. If it can be pushed in adjust rods per step below.

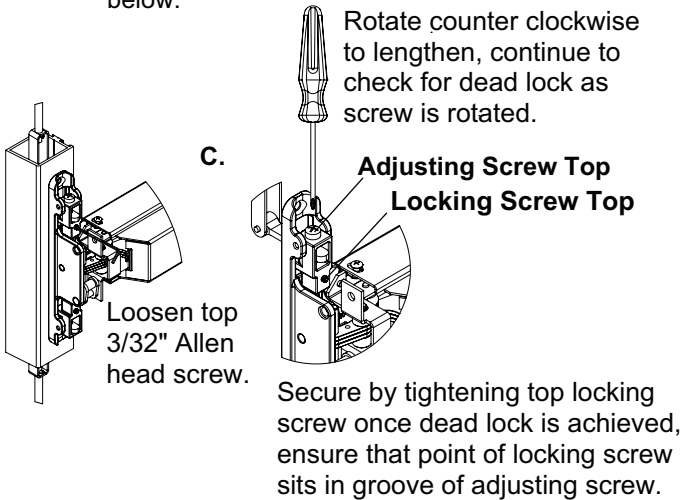

C. Rotate counter clockwise to lengthen, continue to check for dead lock as screw is rotated. **Adjusting Screw Top Locking Screw Top**
Loosen top 3/32" Allen head screw. Secure by tightening top locking screw once dead lock is achieved, ensure that point of locking screw sits in groove of adjusting screw.

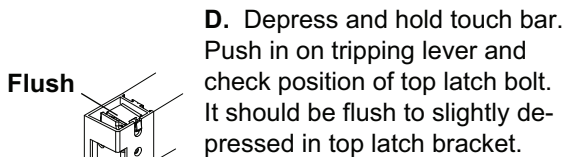

D. Depress and hold touch bar. Push in on tripping lever and check position of top latch bolt. It should be flush to slightly depressed in top latch bracket.

E. Release tripping lever and touch bar, top latch should remain in retracted position

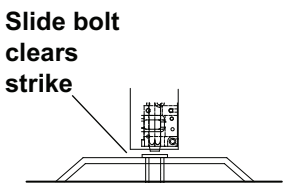

F. With top latch held retracted, adjust bottom rod so slide bolt is flush across bottom of latch bracket and clears threshold, floor and strike. Ensure bottom adjusting screw is flush up against bottom of bell-crank. Held in position by locking screw. Use bottom adjusting screw; follow same steps as above for adjusting top latch bolt. Secure 3/32" Allen screw.

G. Standing on inside, close door and check that top and bottom latch bolts align and engage in top and bottom keeps.

H. After rods are fully adjusted ensure that top and bottom locking screws are tight.

I. Check device operation by opening and closing door several times from **inside**. Check and operate outside trim if installed.

Repeat adjustment procedure if:

Top latch is not held retracted
Bottom slide bolt does not clear strike or floor.
Latches do not work properly with outside trim

J. Install end cap and center case covers. (2) #10 x 25mm F.H.P.T.S.

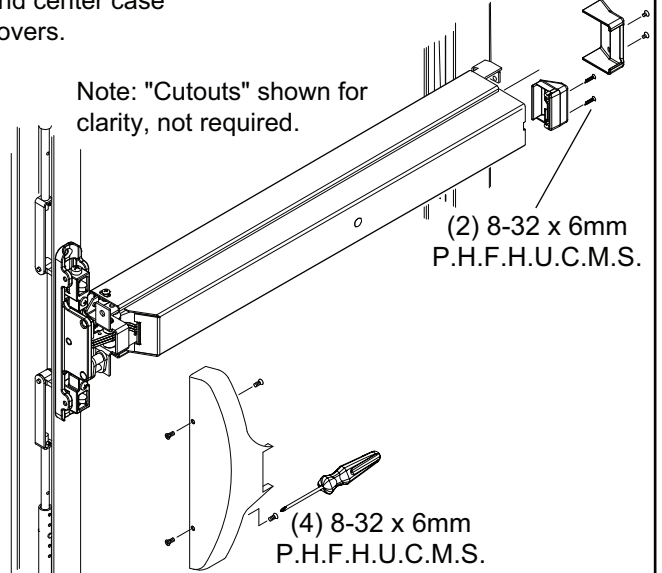

Note: "Cutouts" shown for clarity, not required.

K. Standard hex key dogging, depress touch bar insert supplied hex key and rotate clock wise to dog and counter clock wise to undog.

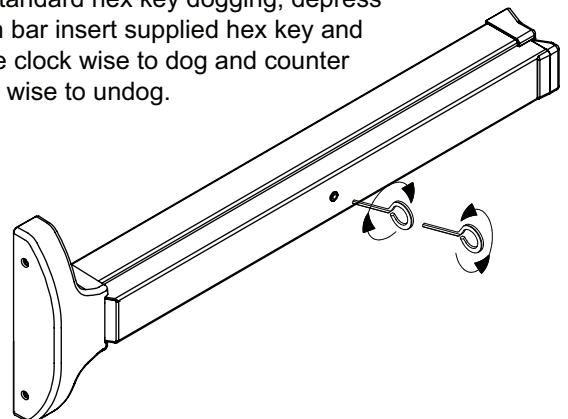

OPTIONS: Cylinder dogging

Cylinder specifications and cams;

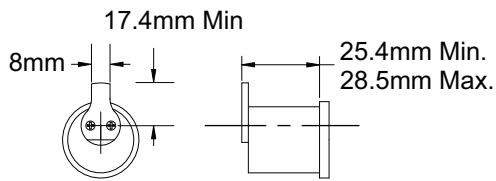

Note: When using IC core cylinders, ensure that cam is in proper position prior to installing the new core.

Useable Cams

Arrow	001	Ilco/Unican	SC1
Assa	Std. (Yale)	Lori	SC1 4200-82-2002 Std.
Best	C136	Sargent	13-0664 or 13-0660
Corbin	A02	Schlage	001
Falcon	12667-3	Yale	2160

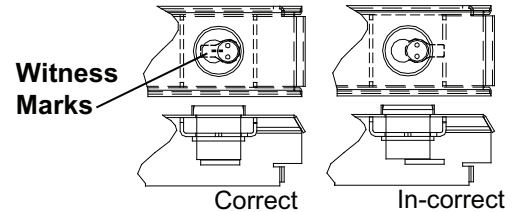

Cylinder dogging option on full length touch bar and rail; (See cam specifications above.)

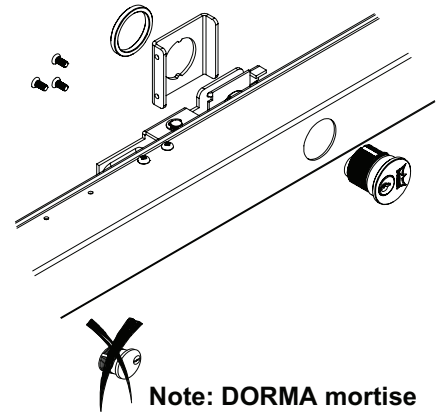
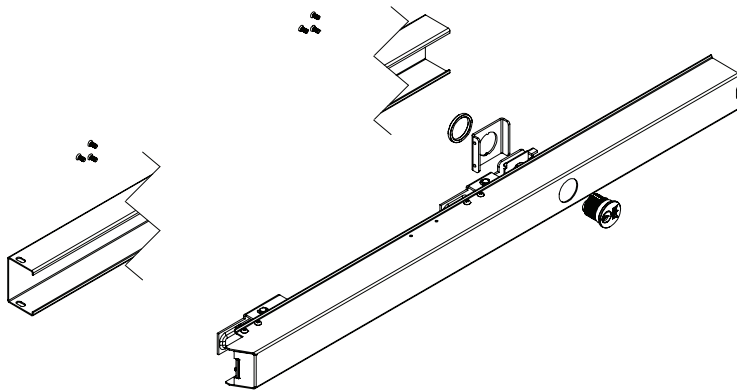

Note: DORMA mortise cylinder supplied. To use other manufacture cylinders, "L" less cylinder is available.

To change cylinder:

1. Remove end cap, end cover & end cap mounting bracket.
2. Remove cover from chassis and two chassis to touch bar mounting screws.
3. Remove (6) touch bar to rail mounting screw from underside of rail.
4. Flip rear arm assembly outward from underside of touch bar.
5. Remove cylinder nut on underside of touch bar.
6. Remove cylinder and mounting plate.
6. Insert new cylinder facing as shown in detail.
7. Install mounting bracket and cylinder nut.
8. Flip rear arm assembly back under touch bar.
9. Re-install touch bar to rail with (6) screws.
10. Install touch bar & rail back on to chassis with (2) screws.
11. Re-install end cap mounting bracket.
12. Re-install end cap, end cover & chassis cover.



OPTIONS

Option: "LM" Latch monitor; monitors movement of latch bolt with or without depressing of touch bar. May be wired either normally open or normally closed.

* **NOTE:** Use caution when cutting touch bar and rail to length. Additional hole required see **step 9**.

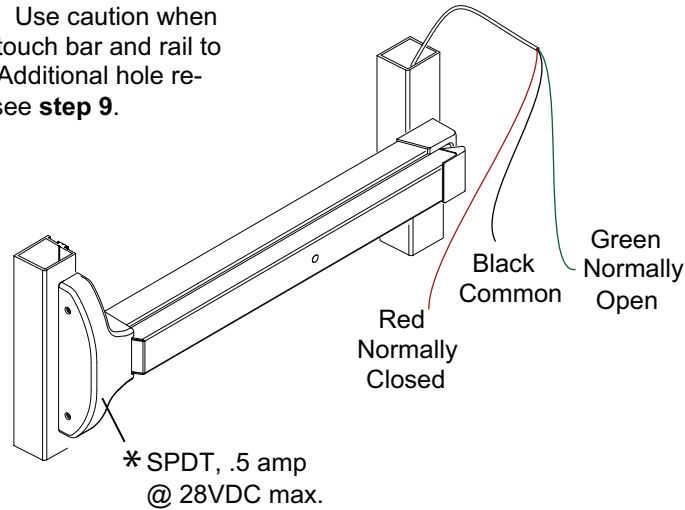

"BPA", "BPAR" & DWA (ALARM) Options; "BPA" Battery powered alarm, sounds continuous until reset. "BPAR" alarm sounds for 4 minutes then will automatically reset. **Alarm mode set at factory.**

Note: On the 9000"FL" version caution must be used when cutting touch bar and rail to length due to the wires running inside of the assembly. A standard **DORMA** cylinder is supplied on both units, to change to a customer supplied cylinder follow steps under "**cylinder dogging**". Refer to additional instruction sheet packed with device for operational instructions etc.

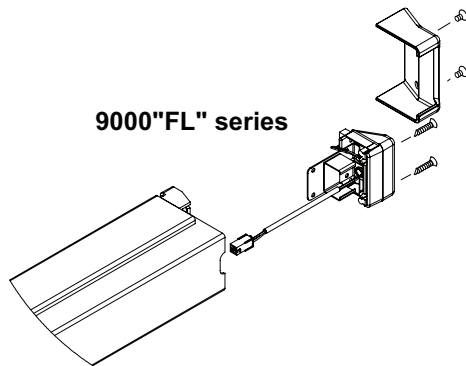

To change battery:

1. Prop open door.
2. Remove (2) end cover mounting screws.
3. Remove (2) end cap screws.
4. Remove end cap & replace battery.
5. Re-install in reverse order.

Size AA:

Fits 1220mm door opening without cutting.
Can be cut to fit a 851mm minimum door opening.

Size BB:

Fits 915mm door opening without cutting.
Can be cut to fit a 699mm minimum door opening.

Size CC:

Fits 915mm door opening with out cutting.
Using a shorter touch pad then the standard "B" size allows it to be cut to 622mm door opening.

"DWA" OPTION:
Battery Eliminator

White
Green
(Non-polarized)

Connected to outside power source; 12-24V AC/DC supply. ie: Dorma ES-100 etc.
Contact Dorma **1-800-523-8483** for other supplies available.

OPTIONS

Option: "ES" Electric latch retraction: Electrically retracts latch bolt(s) when energized by power supply.

Electrically retracts latchbolt(s)
when energized by power supply.

**REQUIRES DORMA ADPS501 POWER SUPPLY
AND ES105 POWER TRANSFER.**

ADPS501 Will operate (2) "ES" 9600 exit devices,
but is capable of powering (2) additional devices
by installing the optional "ES-2" card.

***NOTE:** Use caution when
cutting touch bar and rail to
length. Requires additional
hole see **step 9**.

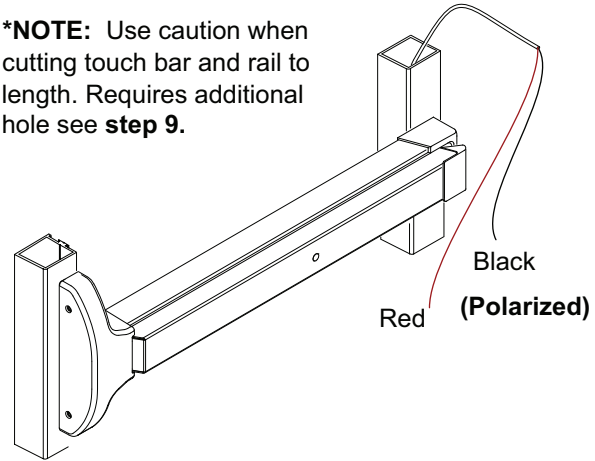

Option: "MS" Monitor Switch: Monitors movement of touch bar, or can be used to signal an external light, horn etc.

Located on the rear arm assembly as shown;
Comes standard with (2) two micro switches.
Both can be wired normally open or normally
closed.

**On the "FL" series it can be added, however
the touch bar must be removed completely
from the rail to install switch assembly.**

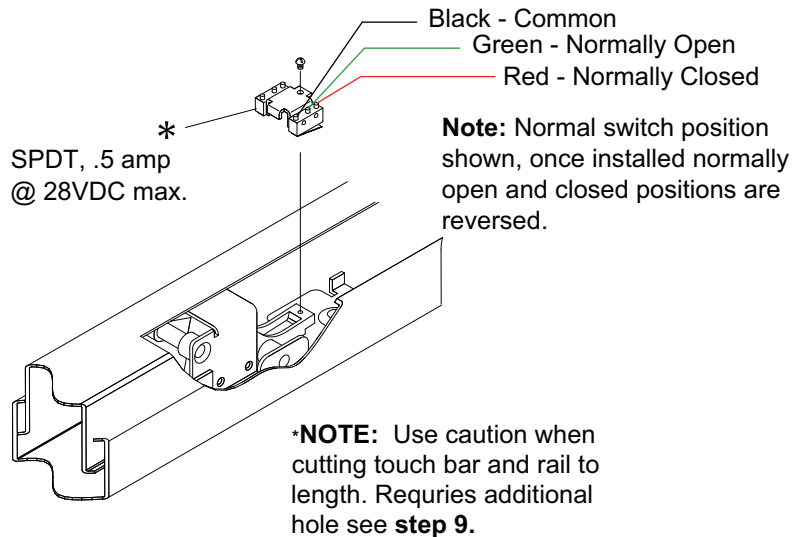

TIMBER DOOR PREP
SEE TEMPLATES FOR ACTUAL PRODUCT ONLINE
AT www.dorma-usa.com

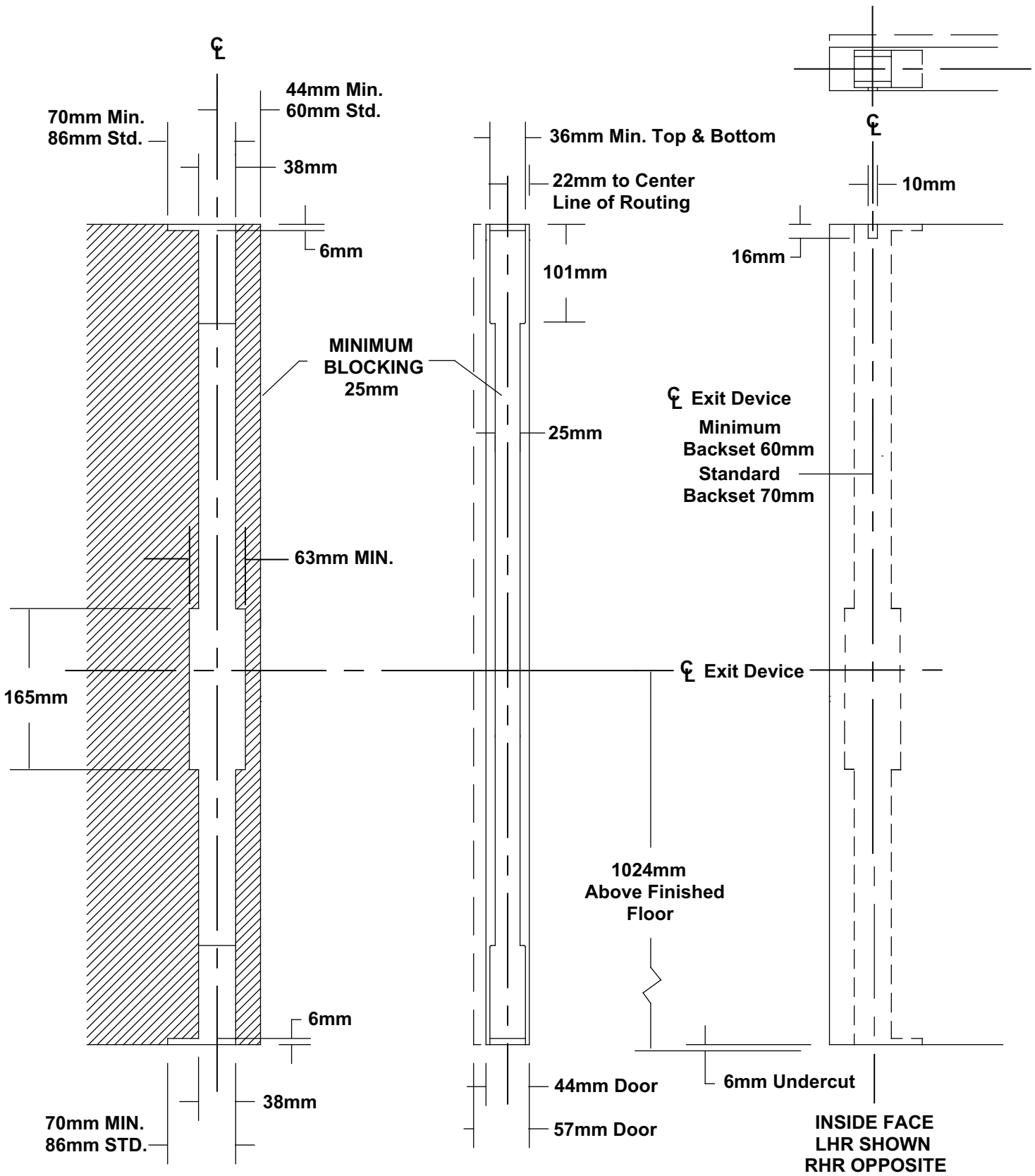

NOT TO SCALE

RETROFIT FROM EXISTING AD4100 TO NEW 9600 MODELS

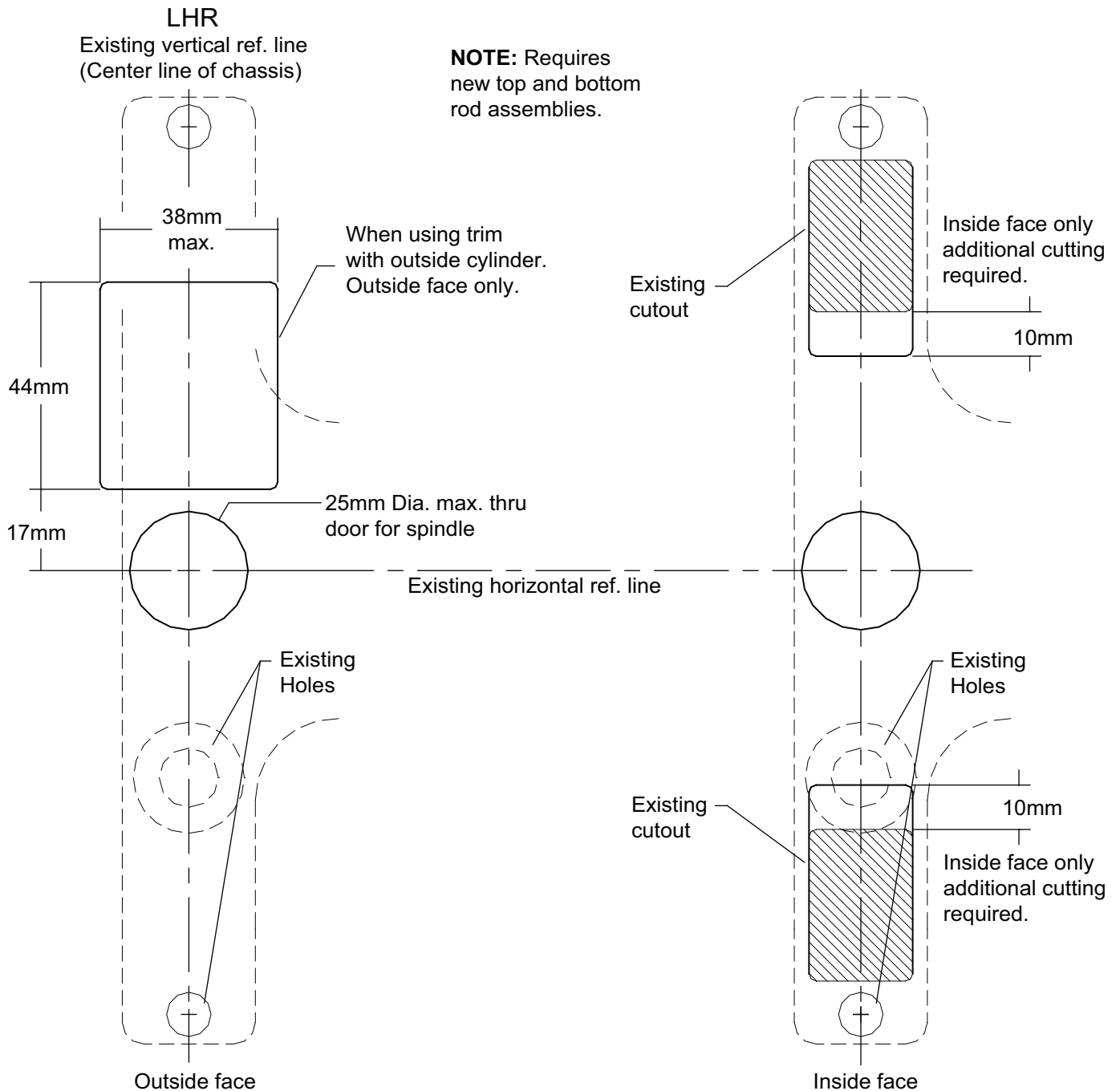

DO NOT SCALE

Additional installation instructions:

Use existing latch and chassis location. **Note: new "Z" trim will be required if trim is used.**

Replace existing rod assemblies with new design. Follow instruction for installing new 9600 series device.

Install chassis assembly to door, install end cap bracket to door, hold touch bar and rail assembly in position aligning screw holes in rail with mounting screw location of chassis, mark a line on rear of rail where front edge of end cap bracket is then cut touch bar and rail assembly to length.

Install touch bar and rail to door then install all covers.

BS EN 1125 : 2008 PANIC EXIT DEVICE ON A SINGLE DOOR
ANNEX A

Installation and Fitting Instructions

A.1 The producer shall specify the appropriate fixing arrangement for the door types for which the exit device is designed.

A.2 Before fitting an exit device to a door, the door should be checked to ensure correct hanging and freedom from blinding.

It is not recommended, for example, that exit devices be fitted to hollow core doors unless specially designed by the producer for this type of door.

It is recommended to verify that the door construction allows the use of the device, i.e. to verify that offset hinges and engaging leaves allow both leaves to be opened simultaneously (See A4), or to verify that the gap between door leaves does not differ from that defined by the exit device producer, or to verify that the opening elements do not interfere, etc.

A.3 Before fitting a panic exit device to a fire/smoke resisting door, the fire certification of the fire door assembly on which the exit device has been tested to prove suitability for use on a fire door should be examined. It is of utmost importance that an exit device is not used on a fire door assembly of a greater fire resistance time than approved for. See Annex B.

A.4 Care should be taken to ensure that any seals or weather-stripping fitted to the complete door assembly, do not inhibit the correct operation of the panic exit device.

A.5 On double doorsets with rebated meeting stiles and where both leaves are fitted with panic exit devices, it is essential to check that either leaf will open when its panic exit device is activated and also that both leaves will open freely when both panic exit devices are operated simultaneously.

A.6 Where panic exit devices are manufactured in more than one size, it is important that the correct size is selected.

A.7 Category 2 (Standard projection) panic exit devices should be used in situations where there is restricted width for escape, or where the doors to be fitted with the panic exit devices are not able to open beyond 90°

A.8 Where a panic exit device is designed to be fitted to a glazed door, it is essential that the glazing is tempered or laminated glass.

A.9 Different fixing can be necessary for fitting panic exit devices to wood, metal or frameless glass doors. For more secure fixing, male and female through-door bolts, reinforcement and rivets can be used.

A.10 Panic exit devices are not intended for use on double action (double swing) doors unless specifically designed by the exit device producer.

A.11 The fixing instructions should be carefully followed during installation. These instructions and any maintenance instructions should be passed on by the installer to the user. See Annex C

A.12 The horizontal bar should normally be installed at a height of between 900mm and 1100mm from the finished floor level, when the door is in the secured position. Where it is known that the majority of the users of the premises will be young children, consideration should be given to reducing the height of the operating bar.

A.13 The horizontal bar should be installed so as to provide the maximum effective length.

A.14 The bolt heads and keepers should be fitted to provide secure engagement. Care should be taken to ensure that no projection of the bolt heads, when in the withdrawn position, can prevent the door swinging freely.

BS EN 1125 : 2008 PANIC EXIT DEVICE ON A SINGLE DOOR
ANNEX A continued

Installation and Fitting Instructions

A.15 Where panic exit devices are to be fitted to double door sets with rebated meeting stiles and self closing devices, a door coordinator device in accordance with EN 1158 (See Bibliography) should be fitted to ensure the correct closing sequence of the doors. This recommendation is particularly important with regard to smoke/fire-resisting door assemblies.

A.16 No devices for securing the door in the closed position should be fitted other than specified in this European Standard. This does not preclude the installation of self-closing devices.

A.17 If a door closing device is to be used to return the door to the closed position, care should be taken not to impair the use of the doorway by the young, elderly and infirm.

A.18 Any keepers or protection plates provided should be fitted in order to ensure compliance with this European Standard.

A.19 A sign which reads "Push Bar to open" or a pictogram should be provided on the inside face of the door immediately above the horizontal bar, or on the bar if it has a sufficient flat face to take the size of lettering required. The surface area of the pictogram should be not less than 8000mm² and its colours should be white on a green background. It should be designed such that the arrow points to the operating element, when installed.

ANNEX C

Maintenance Instructions

The following information shall accompany the product:-

A) Inspect and operate the emergency exit device to ensure that all components are in a satisfactory working condition. Using a force gauge, measure and record the operating forces to release the exit device.

B) Ensure the keeper(s) is (are) free from obstruction.

C) Check that the emergency exit device is lubricated in accordance with the producer's instructions.

D) Check that no additional locking devices have been added to the door since its original installation.

E) Check periodically that all components of the system are still correct in accordance with the list of approved components originally supplied with the system.

F) Check periodically that the operating element is correctly tightened and, using a force gauge, measure the operating forces to release the exit device. Check that the operating forces have not changed significantly from the operating forces recorded when originally installed.

DORMA 9600FL PANIC BOLT

FIXING INSTRUCTIONS

This device is intended for use on single and/ or double outward opening escape route doors.

"This device is not suitable for use on fire doors."

Category of projection = Category 2

Field of door application = Category A

Maximum of 5mm door distortion allowed to ensure safe exit.

Maximum of a 1000N pulling force achieved against the fixing screws.

WARNING

The safety features of this product are essential to its compliance with EN 1125 (2008). No modification of any kind, other than those described in these instructions, is permitted.

Panic devices manufactured in accordance with EN 1125 : 2008) will provide a high degree of safety and reasonable security provided they are fitted to doors and frames of equal quality and in good condition. The doors must be correctly hung and free from binding or any distortion. This device is not recommended for wood hollow core doors.

IMPORTANT

This equipment must be installed by a competent fitter. If these fixing instructions are not followed, then no responsibility for malfunction will be accepted by the manufacturer, and warranty claims may be considered invalid.

These fixing instructions must be passed to the user after installation has been completed.

EN 1125 CLASSIFICATION NUMBER FOR THIS PRODUCT

3	7	6	0	1	3	2	2	B	A
---	---	---	---	---	---	---	---	---	---

DOOR SIZES

This product is suitable for doors up to

Size A 838mm to 1220mm wide, 2500mm high.

Size B 686mm to 915mm wide, 2500mm high.

Size C 610mm to 915mm wide, 2500mm high.

(Doors above 2500mm fall outside the scope of EN 1125)

200Kg door mass maximum.

LHR

VERTICAL REF. LINE
(CENTERLINE OF CHASSIS)

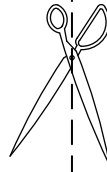

RHR

VERTICAL REF. LINE
(CENTERLINE OF CHASSIS)



EXIT DEVICE
9600FL SERIES

19mm X 41mm
CUTOUT
FOR ROD
CONNECTION
SEE PROPER
OUTSIDE DOOR
TRIM TEMPLATE
FOR TRIM PREP

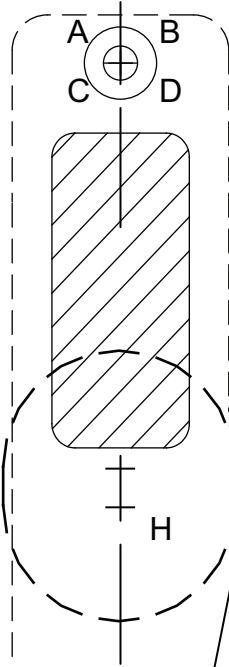

OUTSIDE
FACE ONLY

19mm X 41mm
CUTOUT
FOR ROD
CONNECTION
SEE PROPER
OUTSIDE DOOR
TRIM TEMPLATE
FOR TRIM PREP

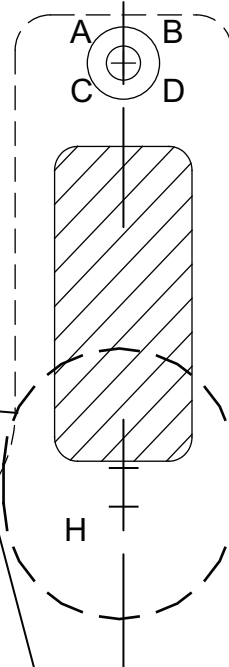

OUTSIDE
FACE ONLY

NOTE: FOR CYLINDER ONLY
FUNCTION SEE PAGE 4
HORIZONTAL REFERENCE LINE

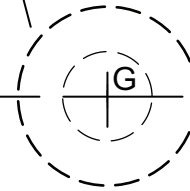
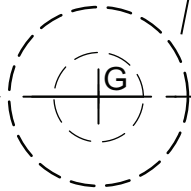

19mm X 41mm
CUTOUT
FOR ROD
CONNECTION
SEE PROPER
OUTSIDE DOOR
TRIM TEMPLATE
FOR TRIM PREP

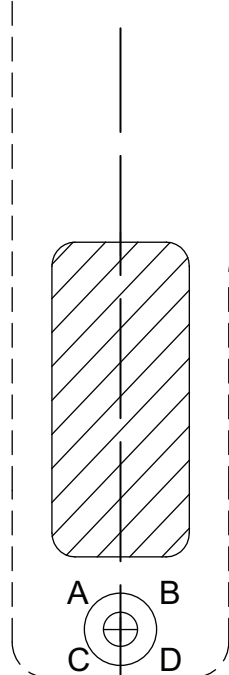

19mm X 41mm
CUTOUT
FOR ROD
CONNECTION
SEE PROPER
OUTSIDE DOOR
TRIM TEMPLATE
FOR TRIM PREP

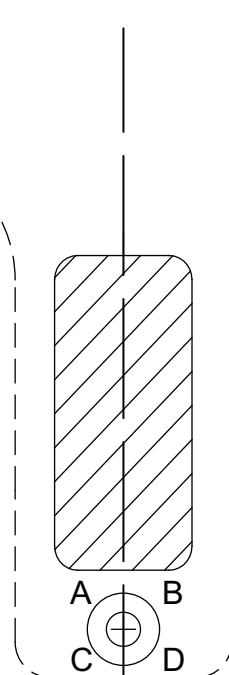

A FOR TIMBER DOOR 3.8 x 25mm DEEP

B FOR METAL DOOR 4.2 x M5 TAP

C FOR SEX BOLT 10mm DIA. HOLE THRU DOOR

D FOR USE WITH TRIM 10mm DIA. HOLE THRU DOOR

G FOR KNOB/LEVER/THUMBTURN 25mm DIA. OUTSIDE FACE
13mm DIA. INSIDE FACE

H FOR KNOB/LEVER/THUMBTURN 25mm DIA. OUTSIDE FACE
38mm DIA. x 44 HIGH FOR CYLINDER CLEARANCE