

Autodesk® Revit® Architecture 2013 Fundamentals



Chapter 2

BIM and Autodesk Revit Architecture

In this chapter you learn about Building Information Modeling (BIM) and how it is used in the Autodesk® Revit® Architecture software. You investigate the software interface and terminology, learn how to start projects, and work with the viewing commands including zoom controls, 3D isometric, and perspective views.

This chapter contains the following topics:

- ✓ **Building Information Modeling**
- ✓ **Overview of the Interface**
- ✓ **Standard Terminology**
- ✓ **Starting Projects**
- ✓ **Viewing Commands**

Learning Objectives

This chapter provides instruction to enable you to do the following:

2.1 Building Information Modeling



Understand the concept of Building Information Modeling and its workflow in relation to the Autodesk Revit software.

2.2 Overview of the Interface



Navigate the graphic user interface.

2.3 Standard Terminology



Use typical terms and concepts found in the software.

2.4 Starting Projects



Start new projects using templates.

2.5 Viewing Commands



Manipulate 2D and 3D views by zooming and panning.



Create 3D Isometric and Perspective views.



Set the Visual Style of a view.

2.1 Building Information Modeling



Understand the concept of Building Information Modeling and its workflow in relation to the Autodesk Revit software.

Building Information Modeling (BIM) is an approach to the entire building life cycle. The BIM process supports the ability to coordinate, update, and share design data with team members throughout the design, construction, and management phases of a building's life.

The Autodesk Revit software is a *Parametric Building Modeler*, and is an important part of the BIM process. *Parametric* means you can establish a relationship between two building elements; when one element changes the other element changes as well. *Building* signifies that this software is designed for working with buildings, as opposed to gears or roads. *Modeler* signifies how a project is built in a single file around the building model (as shown on the left in Figure 2–1). All views, such as plans (as shown on the right in Figure 2–1), elevations, sections, details, schedules, as well as all design sheets printed for construction documents, are automatically generated based on the model.

When a change is made anywhere in the model, all of the views update automatically. For example, if you add an element in a plan view, it displays in the related section view and in schedules (if applicable).

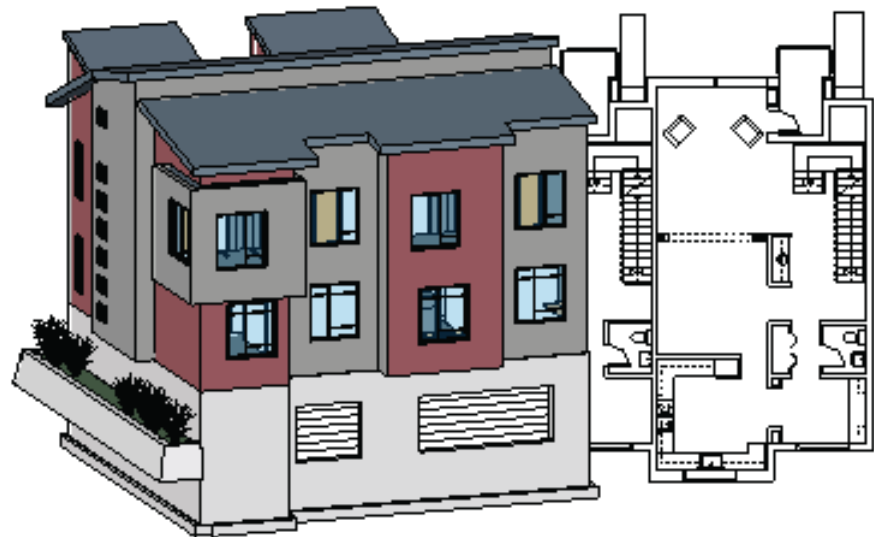

Figure 2–1

- The Autodesk Revit Architecture software coordinates with two other software packages: Autodesk® Revit® MEP (Mechanical, Electrical, and Plumbing) and Autodesk® Revit® Structure. It also enables you to check for interferences between disciplines.

Workflow and BIM

BIM has changed the process of how a building is designed. The Autodesk Revit software is a true BIM product in that it is much more than a drafting software. By creating complete models and associated views of those models, the software takes much of the tediousness out of producing a building design.

In the traditional design process, plans create the basis for the model, from which you then create sections and elevations, as shown in Figure 2–2. Construction Documents (CDs) can then be created. In this workflow, changes are made at the plan level and then coordinated with other documents in the set.

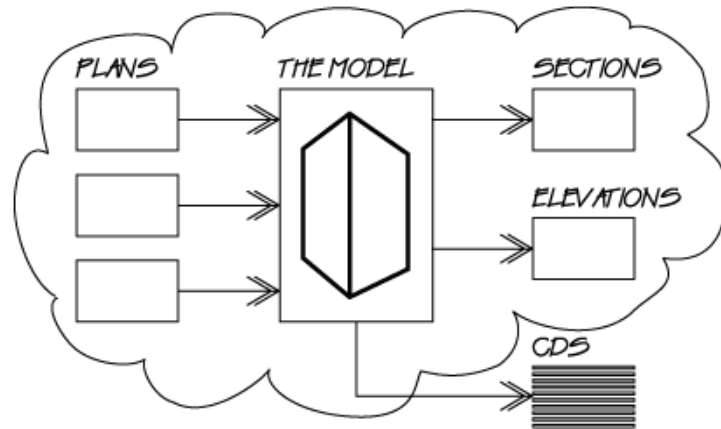

Figure 2–2

In the BIM, the design process revolves around the model, as shown in Figure 2–3. Plans, elevations, and sections are simply 2D versions of the 3D model. Changes made in one view automatically update in all views. Even Construction Documents update automatically with callout tags in sync with the sheet numbers. This is called bidirectional associativity.

*The elements that you create in the software are **smart** elements that know they are walls, windows, doors, or stairs. Because they are smart elements, they display properly in plan, elevation, or 3D views. This ensures that drawings are coordinated across the project because the same model generates all of the necessary views.*

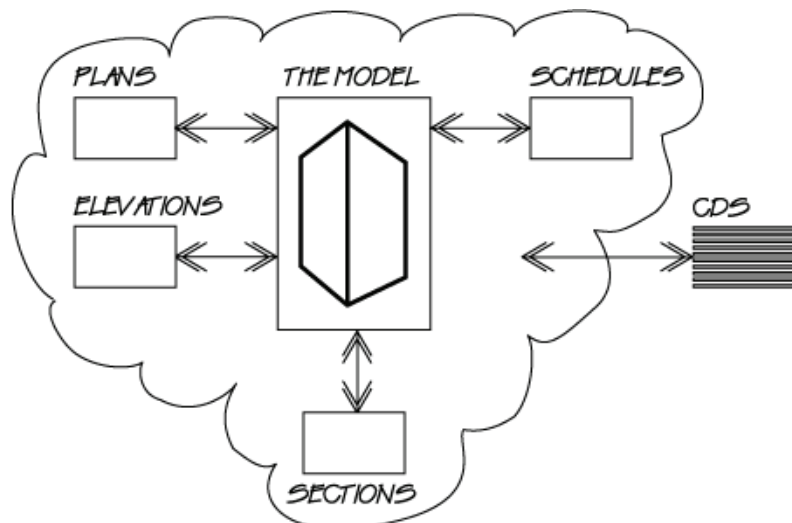

Figure 2–3

Views and Sheets

In the traditional workflow, the most time-consuming part of the project is the construction documents. With BIM, the base views of those documents (i.e., floor plans, ceiling plans, elevations, sections, and schedules) are produced automatically and update as the model is updated, saving hours of work. The views are then placed on sheets that make up the construction document set.

For example, to create a Life Safety Plan, a floor plan is created from the model and then duplicated to create the Life Safety Plan. In the new view, certain categories of elements are turned off (such as grids and section marks), while furniture elements are set to halftone. Annotation is added in regard to exits and room classifications. The plan is then placed on a sheet, as shown in Figure 2–4.

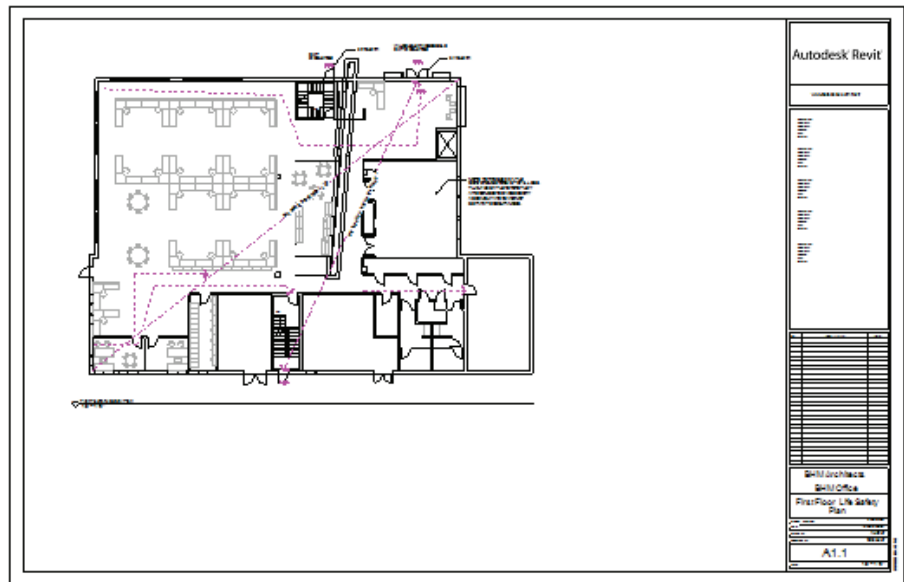

Figure 2–4

- Work can continue on a view and is automatically updated on the sheet.

2.2 Overview of the Interface



Navigate the graphic user interface.

The Autodesk Revit interface is designed for intuitive and efficient access to commands and views. It includes the Ribbon, Quick Access Toolbar, Application Menu, and Status Bar, which are common to the newer versions of all Autodesk® software. It also includes tools that are specific to the Autodesk Revit software, including the Properties palette, Project Browser and View Control Bar. The interface is shown in Figure 2–5.

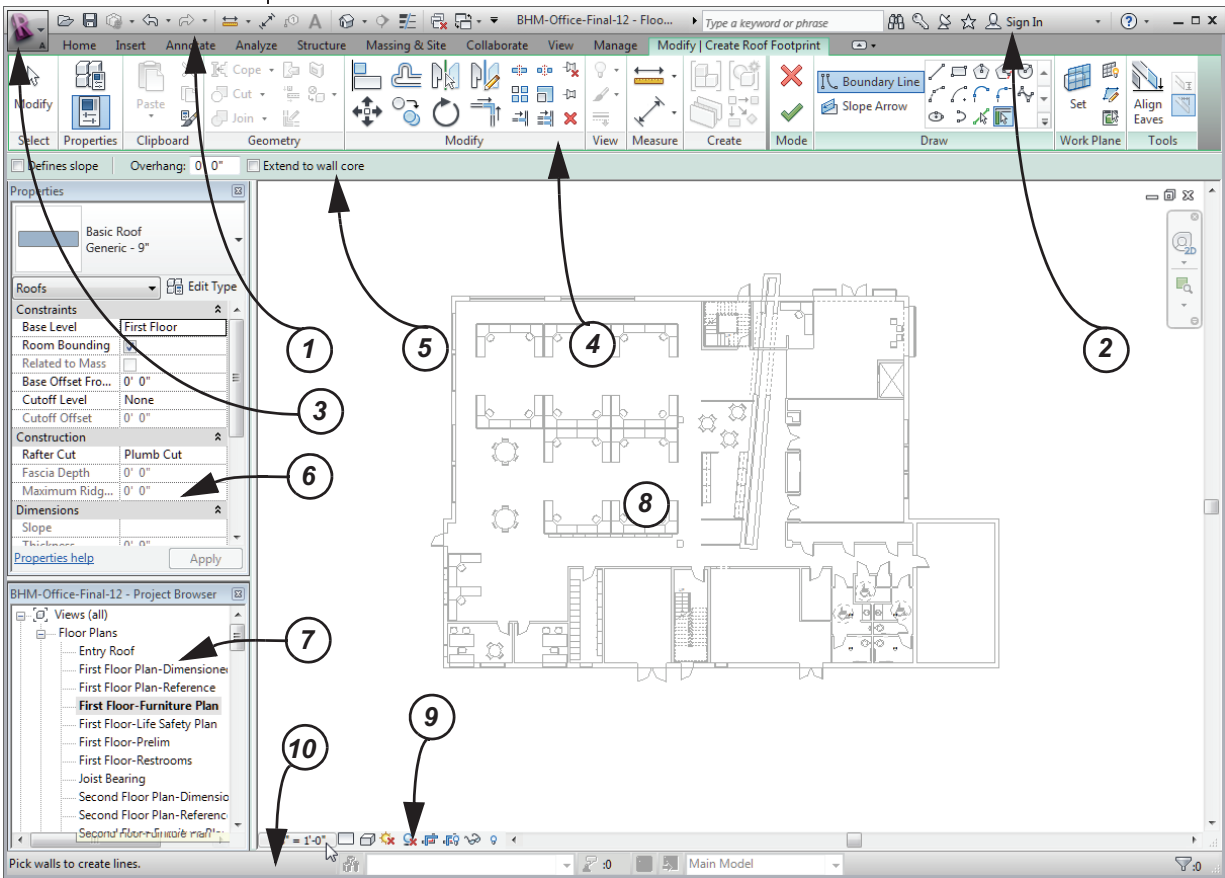

Figure 2–5

- 1. Quick Access Toolbar
- 2. InfoCenter
- 3. Application Menu
- 4. Ribbon
- 5. Options Bar
- 6. Properties Palette
- 7. Project Browser
- 8. Drawing Area
- 9. View Control Bar
- 10. Status Bar

1. Quick Access Toolbar

The Quick Access Toolbar provides access to commonly used commands, such as **Open**, **Save**, **Undo** and **Redo**, **Dimension**, and **3D View**, as shown in Figure 2–6.



Figure 2–6

- The Quick Access Toolbar is easily customizable. Select the arrow at the end of the toolbar. You can choose from the list of commands or click **Customize Quick Access Toolbar** to bring up a dialog box where you can modify the location of the tools on the toolbar as shown in Figure 2–7.

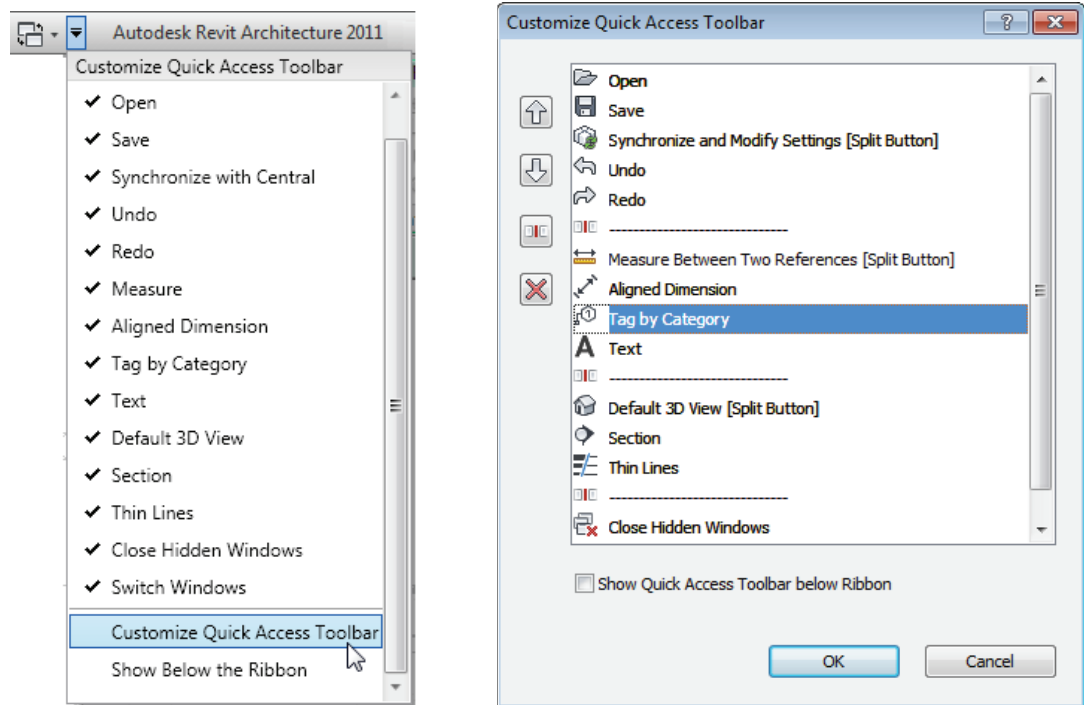

Figure 2–7

- You can also customize it by adding commands from any of the Ribbon tabs. Right-click on the command in the Ribbon and select **Add to Quick Access Toolbar** as shown in Figure 2–8.

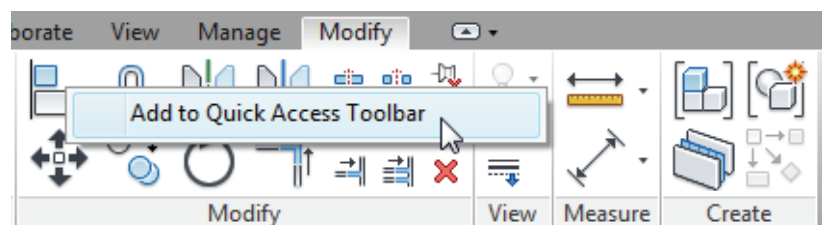

Figure 2–8

2. InfoCenter

The InfoCenter enables you to quickly search for help on the web, as shown in Figure 2–9. You can specify which Help documents to search and collapse or expand the *Search* field to save screen space. You can also sign into Autodesk Online to access additional services and use the Autodesk Exchange Apps website.

You can collapse or expand the Search field to save screen space.



Figure 2–9

3. Application Menu

The Application Menu provides access to file commands, settings, and documents, as shown in Figure 2–10. Hover the cursor over a command to display a list of additional tools.

If you click the primary icon rather than the arrow, it starts the default command.

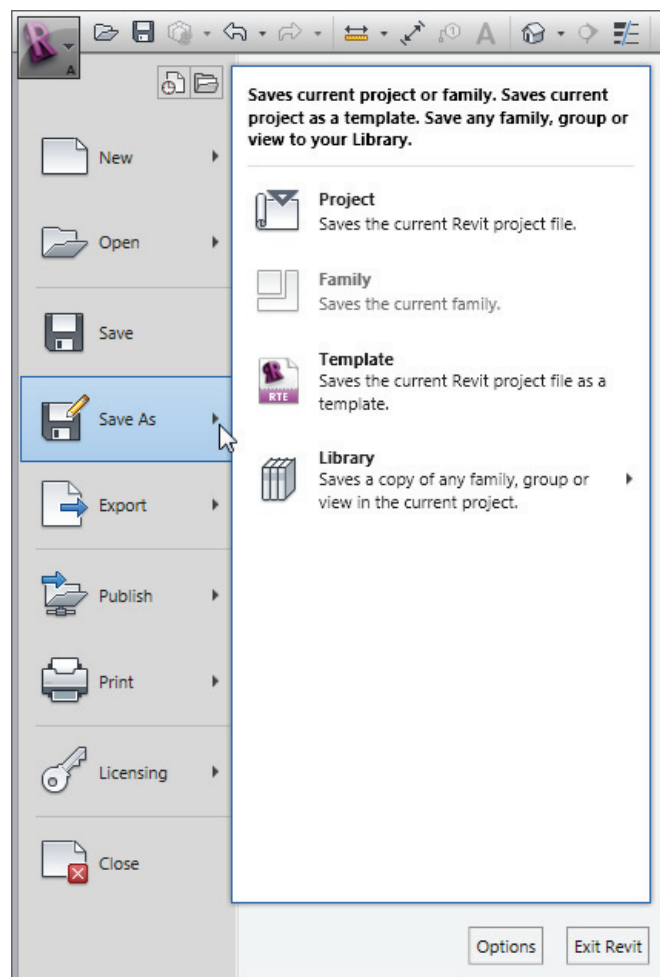



Figure 2–10

- At the bottom of the menu, click **Options** to open the Options dialog box or click **Exit Revit** to exit the program.

Recent Drawings

To display a list of recently used documents click  (Recent Documents) in the Application menu. The documents can be reordered as shown in Figure 2–11.

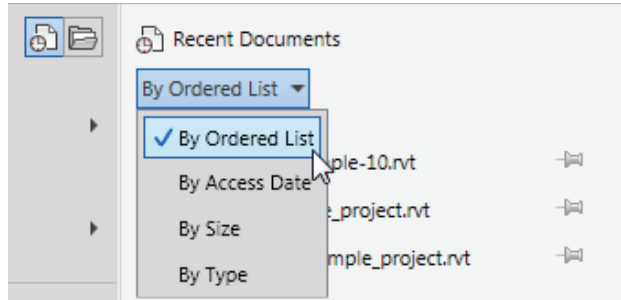





Figure 2–11

- Click  (Pin) next to a document name to keep it available, even if more documents are opened than can be displayed. It displays with the push pin tacked in ().

Open Drawings

To display a list of open documents and views, click  (Open Documents). The list displays the open documents and each view that is open, as shown in Figure 2–12.

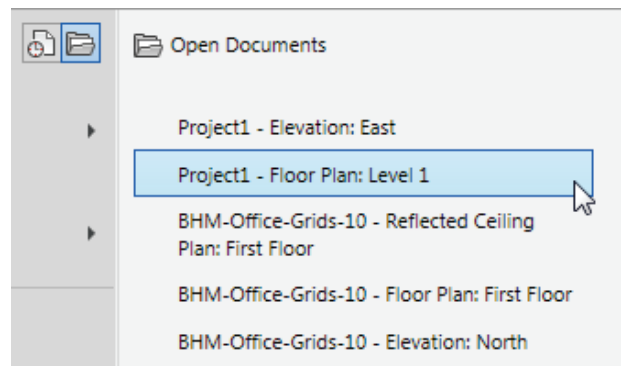





Figure 2–12

- Click  (Close) to close the current project.

You can use the Open Documents list to change between views.

New
in 2013



- When you expand  (Open) there is a new option ( (Sample Files)) that takes you to a folder containing the sample files supplied with the software.

4. Ribbon

The Ribbon contains tools in a series of tabs and panels as shown in Figure 2–13. Selecting a tab displays a group of related panels. The panels contain a variety of tools, grouped by function.

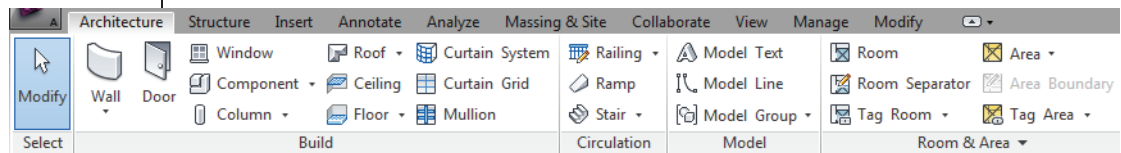

Figure 2–13

When you start a command that creates new elements or you select an element, the Ribbon displays the *Modify* | contextual tab. This contains general editing commands and command specific tools at the end of the tab, as shown in Figure 2–14.

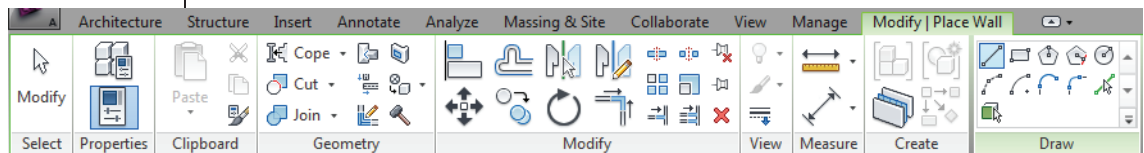

Figure 2–14

- When you hover over a tool on the Ribbon, tooltips display the tool's name and a short description. If you continue hovering over the tool a graphic displays (and sometimes a video) as shown in Figure 2–15.

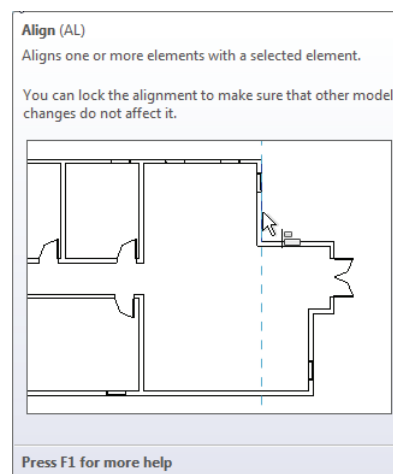

Figure 2–15

- Many commands have shortcut keys. For example, type **AL** for **Align** or **MV** for **Move**. They are listed next to the name of the command in the tooltips. Do not press <Enter> to execute shortcuts.
- The order in which the Ribbon tabs are displayed can be modified. Select the tab, hold down <Ctrl>, and drag it to a new location. The location is remembered when you restart the program.
- Any panel can be dragged by its title into the drawing area to become a floating panel. Click the **Return Panels to Ribbon** button as shown in Figure 2–16 to replace the panel.

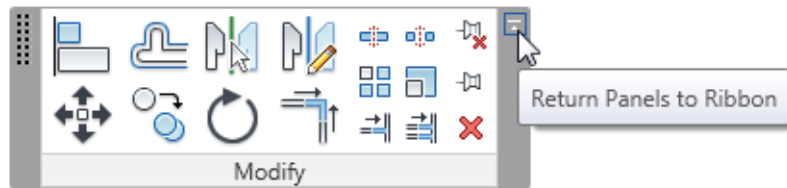



Figure 2–16

Hint: You are always in a command when using the Autodesk Revit software.

When you are finished working with a tool, you typically default back to the **Modify** command. To end a command, use one of the following methods:

- In any Ribbon tab, click  (Modify).
- Press <Esc> once or twice to revert to **Modify**.
- Right-click and select **Cancel...**
- Start another command.

5. Options Bar

The Options Bar displays options that are related to the selected command or element. For example, when the **Rotate** command is active it displays options for rotating the selected elements, as shown at the top of Figure 2–17. When the **Place Dimensions** command is active it displays dimension related options, as shown at the bottom of Figure 2–17.

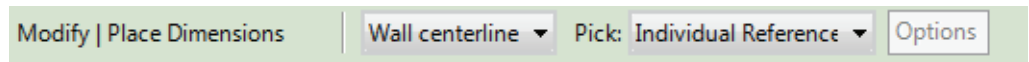
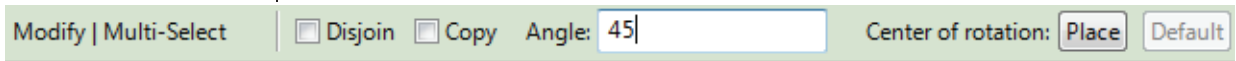

Figure 2–17

6. Properties Palette

In the Properties palette you can make extensive modifications to views and elements. If nothing is selected and you are not in a command, the Properties palette displays options for the current view, as shown on the left in Figure 2–18. If a command or element is selected, it displays options for the associated element, as shown on the right in Figure 2–18.

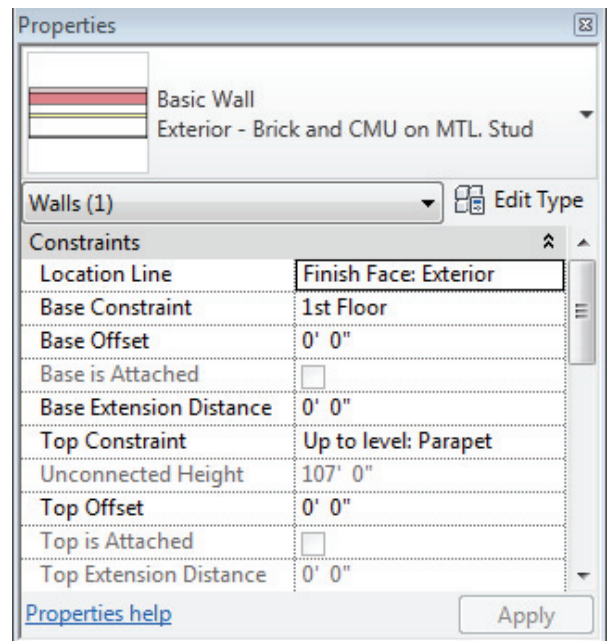
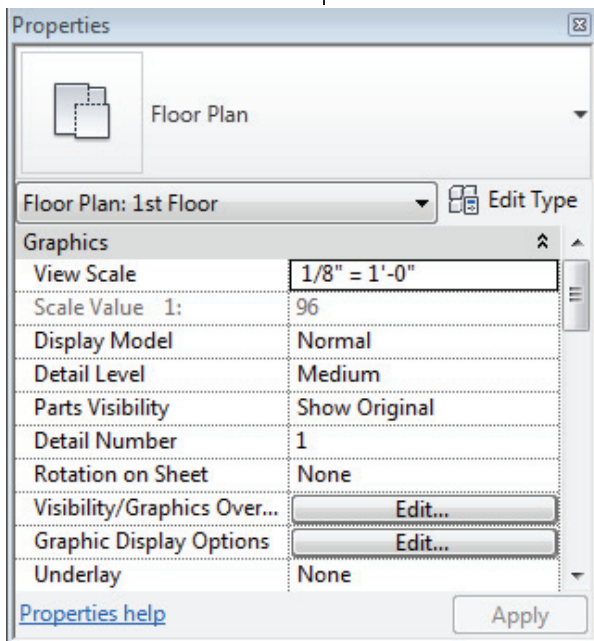



Figure 2–18

- Items that are grayed out are read-only.

- The Properties palette is usually kept open while working on a project to easily permit modifications at any time. It can be placed on a second monitor as well as floated and resized.
- If the Properties palette does not display, click  (Properties) in the *Modify* tab>Properties panel, or type **PP**.
- When multiple elements are selected, you can filter the elements selected in the Properties palette using the drop-down list, as shown in Figure 2–19.

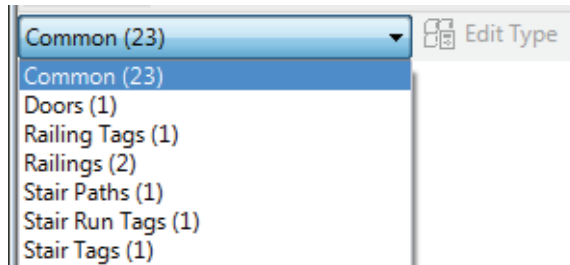

Figure 2–19

- When you start a command or select an element, you can set the element type in the Type Selector as shown in Figure 2–20.

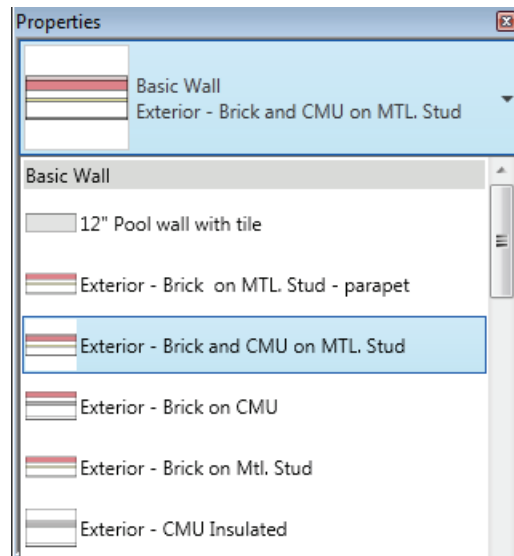



Figure 2–20

Right-click on the Type Selector to add it to the Quick Access Toolbar and/or to the Ribbon Modify tab.

Hint: Type Properties

Type Properties are parameters that are common to all of the elements in a specific family. When a single type of element is selected, click  (Edit Type) in Properties to open the Type Properties dialog box, as shown in Figure 2–21.

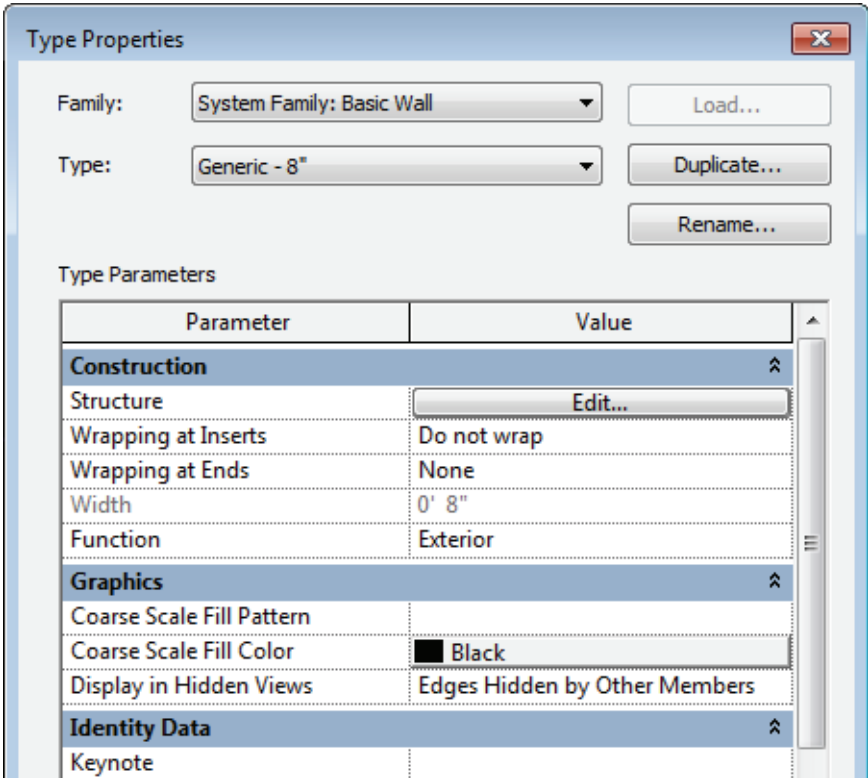

Figure 2–21

7. Project Browser

The Project Browser lists the views that can be opened in the software as shown in Figure 2–22. This includes all views of the model in which you are working and any additional views that you create, such as floor plans, ceiling plans, 3D views, elevations, sections, etc. It also includes views of schedules, legends, sheets (for plotting), families (such as doors and walls), groups, and Revit Links.

The Project Browser displays the name of the active project.

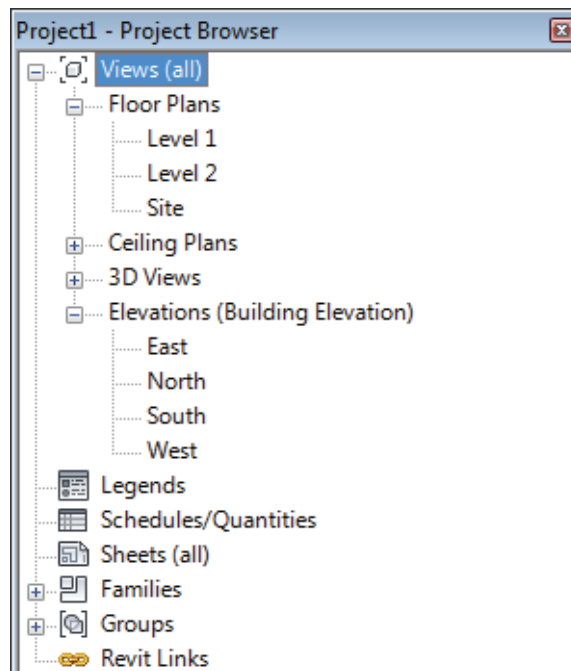



Figure 2–22

- Double-click on an item in the list to open the associated view.
- To display the views associated with a view type, click  (Expand) next to the section name. To hide the views in the section, click  (Contract).
- Right-click on a view and select **Rename** or press <F2> to rename a view in the Project Browser.
- If you no longer need a view, you can remove it. Right-click on its name in the Project Browser and select **Delete**.
- The Project Browser can be floated, resized, and customized.



Search the Project Browser

1. In the Project Browser, right-click on the top level Views node as shown in Figure 2–23.

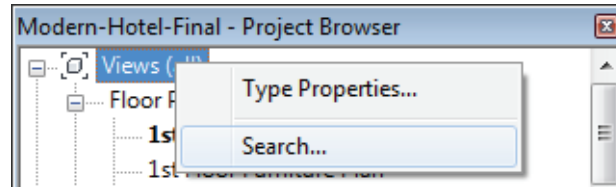
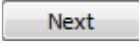

Figure 2–23

2. In the Search in Project Browser dialog box, type the words that you want to find (as shown on the left in Figure 2–24), and click .
3. In the Project Browser, the first instance of that search displays as shown on the right in Figure 2–24.

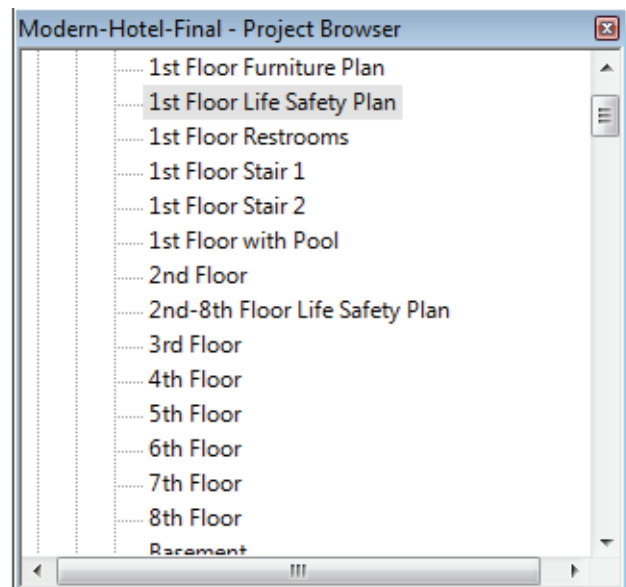
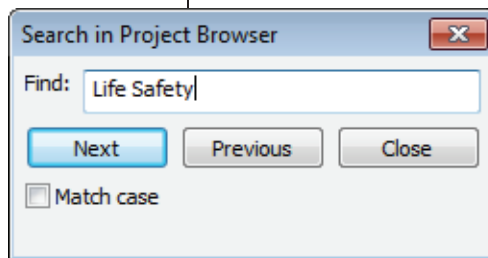
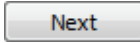
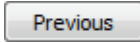
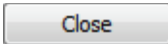

Figure 2–24

4. Continue using  and  to move through the list.
5. Click  when you are done.

8. Drawing Area

Each view of a project opens in its own window, as shown in Figure 2–25. Each view displays a Navigation Bar (for quick access to viewing tools) and the View Control Bar.

In 3D views you can also use the ViewCube to rotate the view.

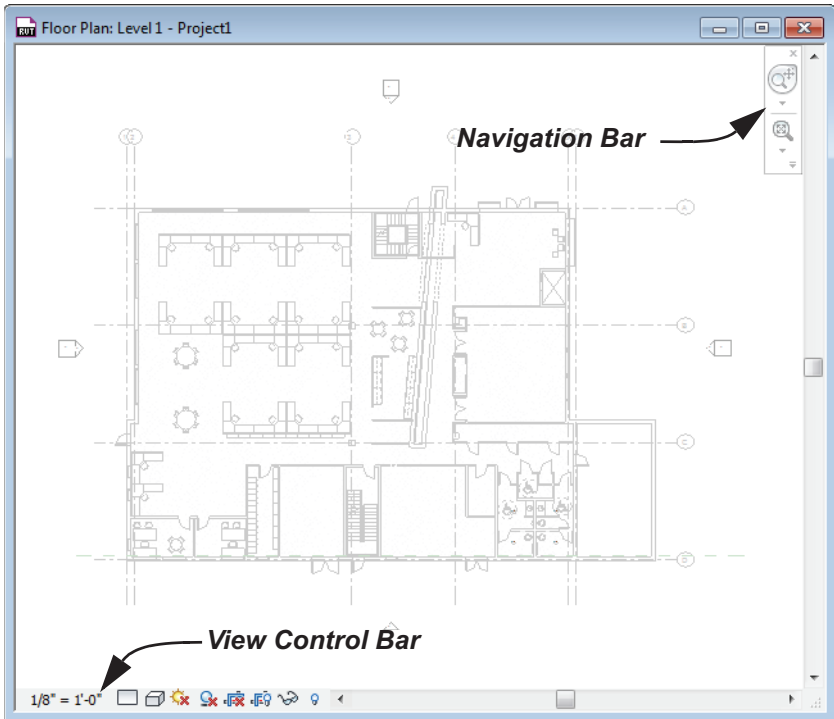





Figure 2–25

- Each view of a project opens in its own window. You can use the Project Browser or press <Ctrl>+<Tab> to cycle through the open views.
- If you have multiple views open you can select a view by name. In the Quick Access Toolbar or *View* tab>*Windows* panel, expand  (Switch Windows) and select from the list.
- If you have more than one view open, click  (Cascade) or  (Tile) in the *View* tab>*Windows* panel to arrange them in the selected order on the screen. You can also use the shortcut keys **WC** for **Cascade** and **WT** for **Tile**.

9. View Control Bar

The View Control Bar (shown in Figure 2–26), displays at the bottom of each view window. It controls aspects of that view, such as the scale and detail level. It also includes tools that display parts of the view and hide or isolate elements in the view.



Figure 2–26

10. Status Bar

The Status Bar provides information about the current process, such as the next step for a command, as shown in Figure 2–27.

Click to enter wall start point.

Enter wall end point. (SZ) to close loop. Space flips orientation.

Figure 2–27

- Other options in the Status Bar are related to Worksets and Design Options (advanced tools) as well as selection methods and filters.

Hint: Right-click Menus

Right-click menus help you to work smoothly and efficiently by enabling you to quickly access the required commands. These menus always provide access to basic viewing commands as well as recently used commands, as shown in Figure 2–28. The other options vary depending on the selected element or command that you are using.

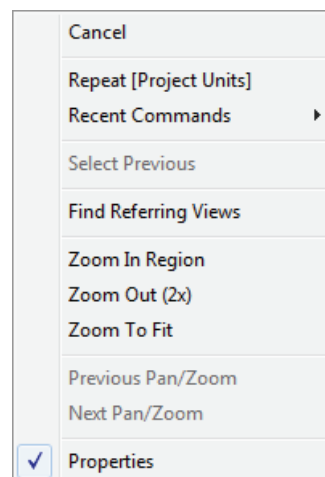

Figure 2–28

 **Certification**

Topic:

- ✓ Elements

Objectives:

- ✓ Modify an element's type parameters

2.3 Standard Terminology



Use typical terms and concepts found in the software.

As you start working with BIM based software, you should know the typical terms used to describe items in the Autodesk Revit software. There are several types of elements, as shown in Figure 2–29, and described in the following table.

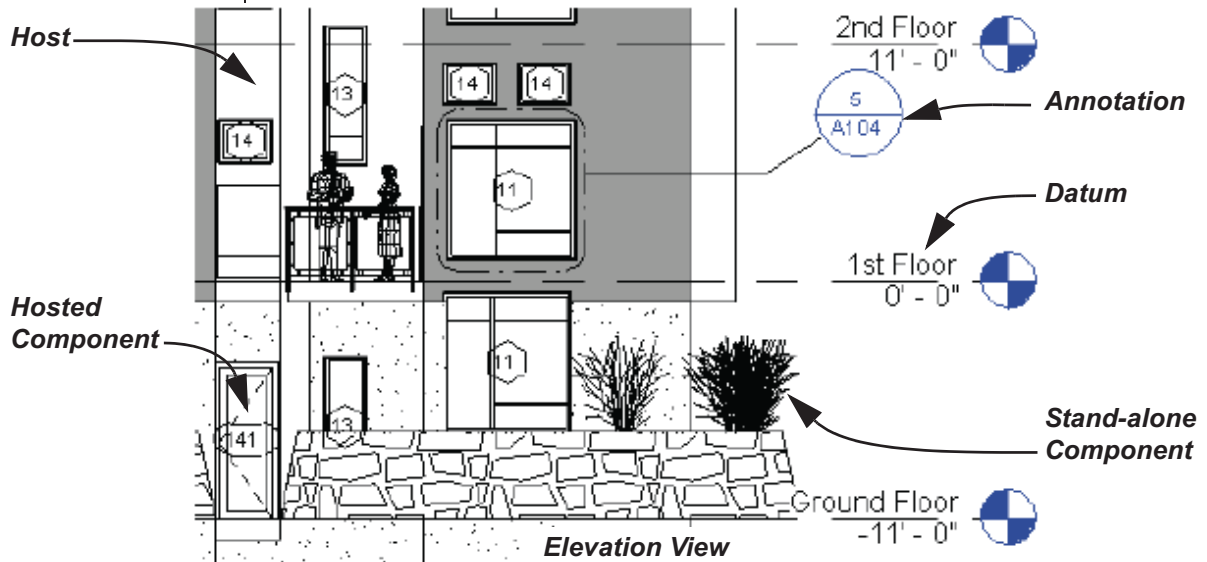

Figure 2–29

Host	<i>Built-in-place</i> construction elements (such as floors, walls, roofs, ceilings, stairs, and ramps). They can stand alone in the project.
Components	Elements that need to be attached to host elements (such as doors, windows, and railings), as well as stand-alone items (such as furniture and equipment).
Views	Enables you to display and manipulate the project. For example, you can view and work in floor plans, ceiling plans, elevations, sections, schedules, and 3D views. You can change a design from any view. All views are stored in the project.
Datum	Elements that define the project context. These include levels for the floors, column grids, and reference planes that help you draw.
Annotation	2D elements that are placed in views to define the information drawn in the project. These include dimensions, text, tags, and symbols. The view scale controls their size.

Property Types

There are two types of properties for most elements in the software:

- **Instance Properties:** Parameters that can be set for the individual element you are drawing or modifying. They display in the Properties palette.
- **Type Properties:** Control options for all elements of the same type. If you modify these parameters, all elements of the selected type change.

Instance properties display in the Properties palette, and can be toggled on/off in the *Modify* tab>Properties panel (as shown in Figure 2–30) or by typing the shortcut **PP**.

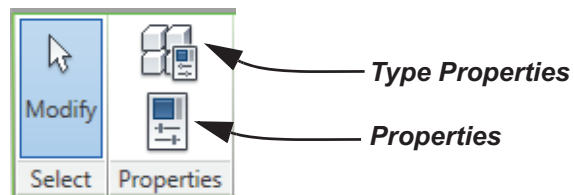



Figure 2–30

- To display the type properties, click  (Edit Type) in Properties to open the Type Properties dialog box, as shown in Figure 2–31. Any changes you make in the Type Properties dialog box impact all instances of the type in the project.

The parameters shown in the dialog boxes vary according to the type of element selected.

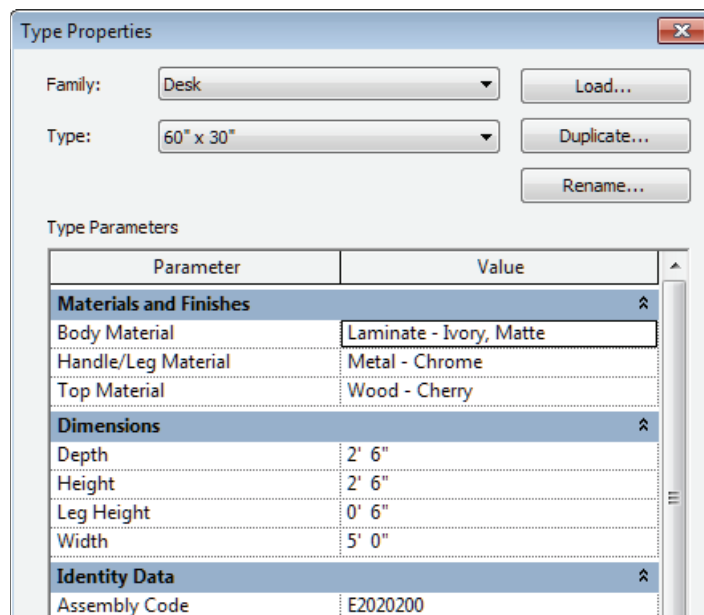

Figure 2–31



Certification

Topic:

✓ Elements

Objectives:

✓ Use Revit family templates

2.4 Starting Projects



Start new projects using templates.

File operations to open existing files, create new files from a template, and save files in the Autodesk Revit software follow standard Windows procedures, as shown in the Open dialog box in Figure 2–32.

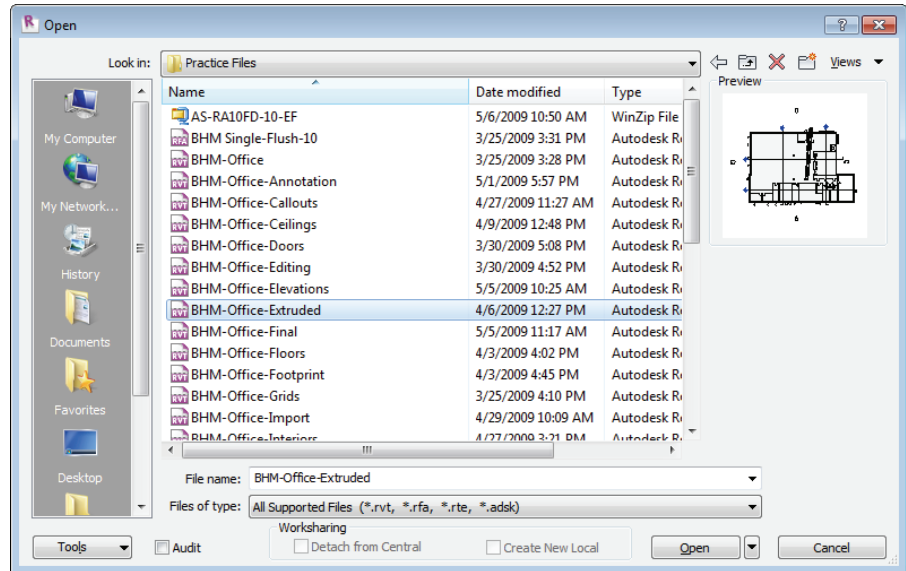

Figure 2–32

There are three main file types:

- **Project files (.rvt):** Your primary drawing files. This is where you do the majority of your work in the building model with views and sheets. They are initially based on template files.
- **Family files (.rfa):** Separate components that can be inserted in a project. For example, the Single Flush and Double Glass door families include a variety of door sizes, and the Desk family includes a number of desk sizes and styles. Title block and Annotation Symbol files are special types of family files.
- **Template files (.rte):** Designed to hold standard information and settings for creating new project files. The software includes several templates for residential, commercial, and structural projects. You can also create custom templates.

When you first open the Autodesk Revit software, the Startup Screen displays, showing lists of recently used project and family files. This screen also displays if you close all projects.

Hint: Opening Workset-Related Files

Worksets are used when the project becomes large enough for multiple people to work on it at the same time. At this point, the project manager creates a central file with multiple worksets (such as element interiors, building shell, and site) that are used by the project team members.

When you open a workset related file it creates a new local file on your computer as shown in Figure 2–33. Do not work in the main central file.

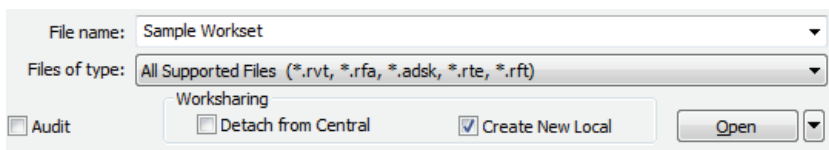



Figure 2–33

Starting New Projects

New projects are based on a template file. The template file includes preset levels, views, and some families, such as wall styles and text styles. Check with your BIM Manager about which template you need to use for your projects. Your company might have more than one based on the types of building you are designing.

How to:

Start a New Project

1. In the Application Menu, expand  (New) and click  (Project), as shown in Figure 2–34.

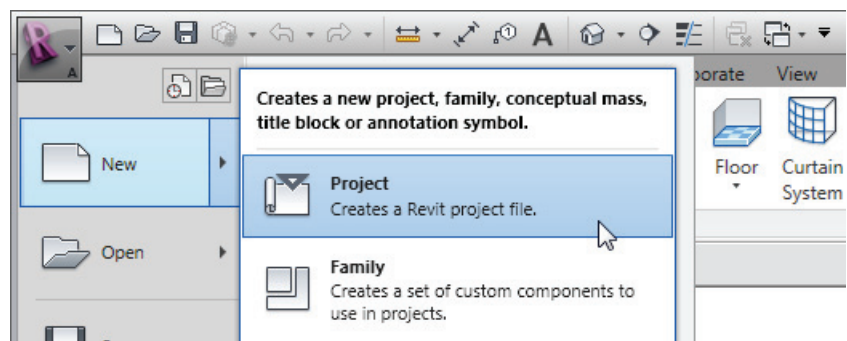
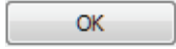

Figure 2–34

New in 2013



The list of Template files is set in the Options dialog box in the File Locations pane. It might vary depending on the installed product and company standards.

- In the New Project dialog box (shown in Figure 2–35), select the template that you want to use and click .

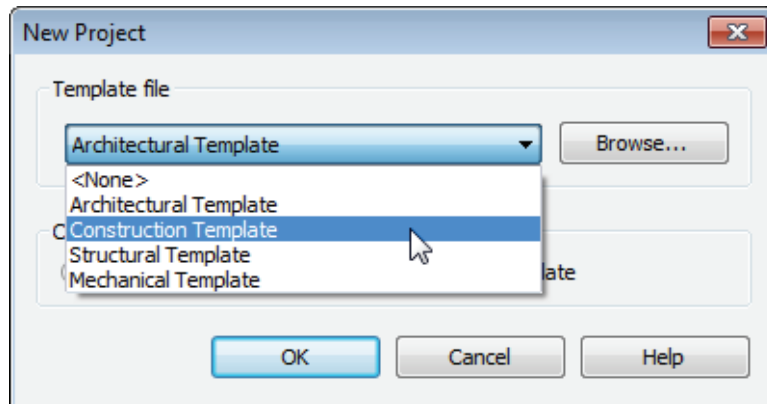



Figure 2–35

- You can select from a list of templates if they have been set up by your BIM Manager.
- You can add  (New) to the Quick Access Toolbar. At the end of the Quick Access Toolbar, click  (Customize Quick Access Toolbar) and select **New**, as shown in Figure 2–36.

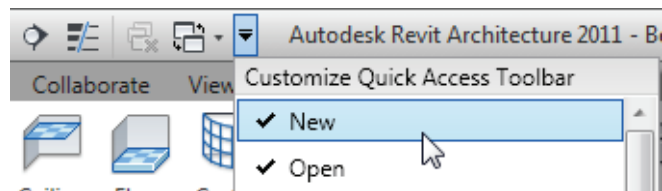





Figure 2–36

Saving Projects

Saving your project frequently is a good idea. Click  (Save) in the Quick Access Toolbar to do this at any time. If the project has not yet been saved, the Save As dialog box opens, where you can specify a file location and name.

- To save an existing project with a new name, in the Application Menu, expand  (Save As) and click  (Project).

- If you have not saved in a set amount of time, the software opens the Project Not Saved Recently alert box, as shown in Figure 2–37. Select **Save the project**. If you want to set reminder intervals or not save at this time, select the other options.

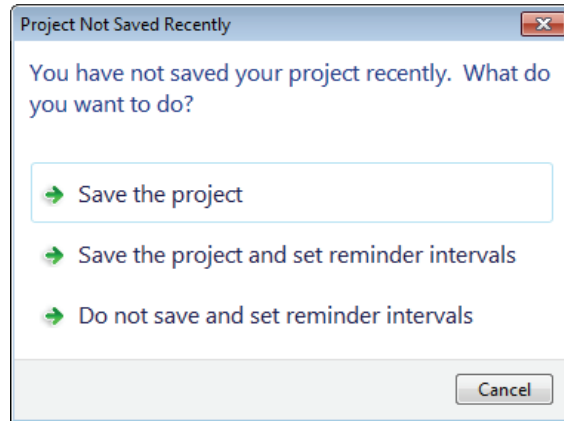



Figure 2–37

- You can set the *Save Reminder interval* to **15 or 30 minutes, 1, 2, or 4 hours**, or to have **No reminders** display. In the Application Menu, click  to open the Options dialog box. In the left pane, select **General** and set the interval as shown in Figure 2–38.

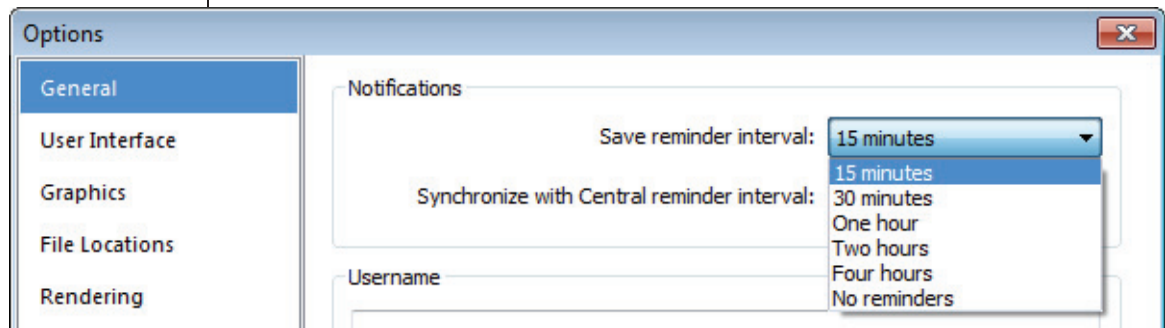
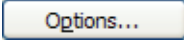

Figure 2–38

Saving Backup Copies

By default, the software saves a backup copy of a project file when you save the project. Backup copies are numbered incrementally (e.g., **My Project.0001.rvt**, **My Project.0002.rvt**, etc.) and are saved in the same folder as the original file. In the

Save As dialog box, click  to control how many backup copies are saved. The default number is three backups. If you exceed this number, the software deletes the oldest backup file.



Hint: Saving Workset-Related Projects

If you use worksets in your project, save locally and to the central file. Save the local file frequently just like any other file.

Then, every hour or so, click  (Synchronize Now) in the Quick Access Toolbar to save your changes back to the main file. After you save to central, save the local file again.

If you use  (Synchronize with Central), you can specify that the local file is saved before or after the synchronization.

2.5 Viewing Commands

-  Manipulate 2D and 3D views by zooming and panning.
-  Create 3D Isometric and Perspective views.
-  Set the Visual Style of a view.

Zoom commands are crucial to working efficiently in most drawing programs and the Autodesk Revit software is no exception. Once in a view, you can use the Zoom controls to navigate within it. You can zoom in and out and pan in any view. There are also special tools for viewing in 3D.

Zooming and Panning

Using Your Mouse to Zoom and Pan

Use your mouse wheel (as shown in Figure 2–39) as the main method of moving around the drawing.

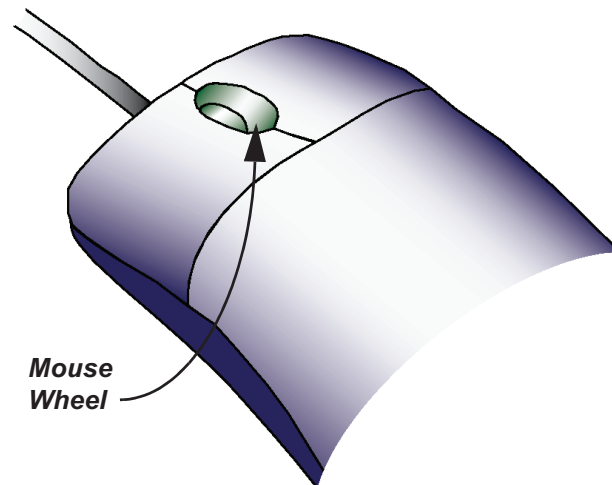

Figure 2–39

- Scroll the wheel on the mouse up to zoom in and down to zoom out.
- Hold down the wheel and move the mouse to pan.
- Double-click on the wheel to zoom to the extents of the drawing.
- In a 3D view, hold down <Shift> and the mouse wheel and move the mouse to rotate around the model.

New
in 2013 

Zoom Controls

A number of additional zoom methods enable you to control the screen display. **Zoom** and **Pan** can be performed at any time while using other commands.

- You can access the **Zoom** commands in the Navigation Bar in the upper right corner of the view (as shown in Figure 2–40). You can also access them from most right-click menus and by typing the shortcut commands.



(2D Wheel)
provides cursor-specific
access to **Zoom** and
Pan.

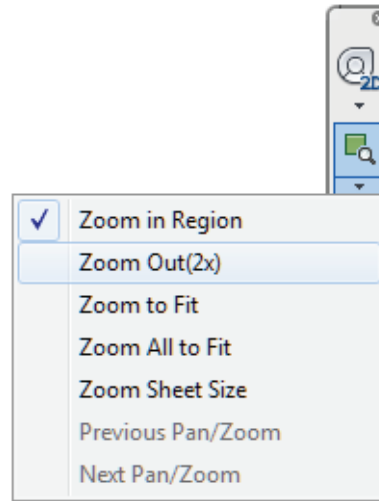







Figure 2–40

Zoom Commands

	Zoom In Region (ZR)	Zooms into a region that you define. Drag the cursor or select two points to define the rectangular area you want to zoom into. This is the default command.
	Zoom Out(2x) (ZO)	Zooms out to half the current magnification around the center of the elements.
	Zoom To Fit (ZF or ZE)	Zooms out so that the entire contents of the project only display on the screen in the current view.
	Zoom All To Fit (ZA)	Zooms out so that the entire contents of the project display on the screen in all open views.
	Zoom Sheet Size (ZS)	Zooms in or out in relation to the sheet size.
	Previous Pan/Zoom (ZP)	Steps back one Zoom command.
	Next Pan/Zoom	Steps forward one Zoom command if you have done a Previous Pan/Zoom .

Viewing in 3D

*There are two types of 3D views: isometric views created by the **3D View** command and perspective views created by the **Camera** command.*

How to:

You can spin the view to a different angle using the mouse wheel or the middle button of a three-button mouse. Hold down <Shift> as you press the wheel or middle button and drag the cursor.

Even if you started a project entirely in plan views, you can quickly create 3D views of the model, as shown in Figure 2–41.

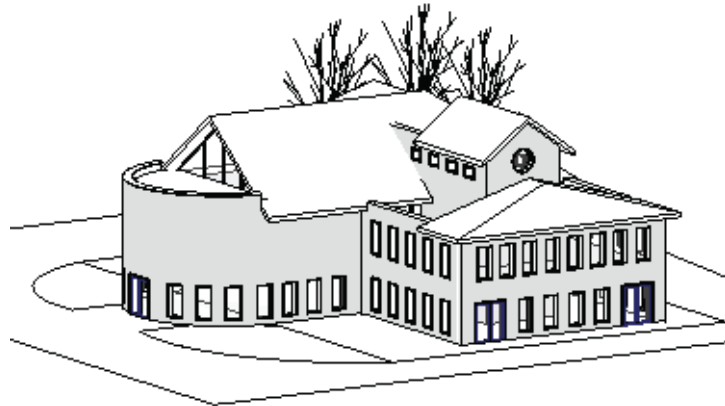



Figure 2–41

Working in 3D views helps you visualize the project and position some of the elements correctly. You can create and modify elements in 3D views just as in plan views.

- Once you have created a 3D view, you can save it and easily return to it.

Create and Save a 3D Isometric View

1. In the Quick Access Toolbar, click  (Default 3D View). The default 3D Southeast isometric view opens, as shown in Figure 2–42.

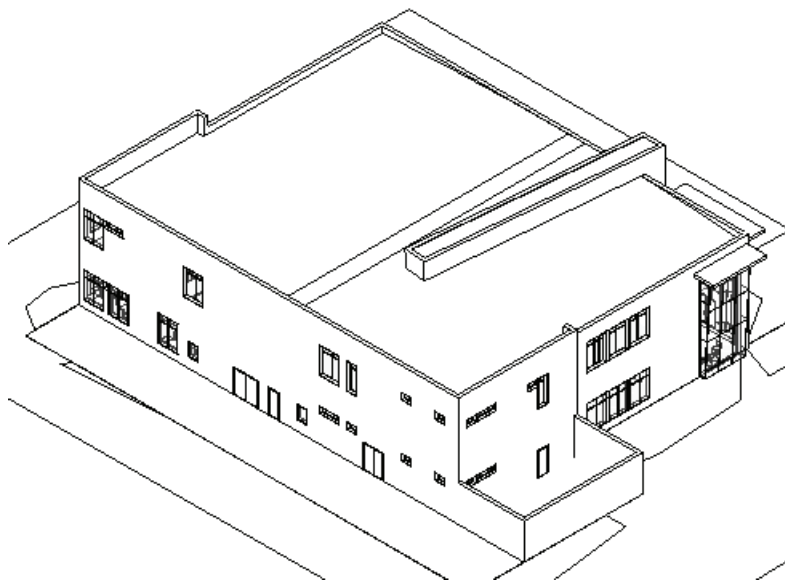
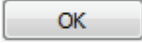

Figure 2–42

2. Modify the view to display the building from other directions.

You can also rename perspective views.

3. In the Project Browser, right-click on the {3D} view and select **Rename...**
4. Type a new name in the Rename View dialog box, as shown in Figure 2–43, and click .

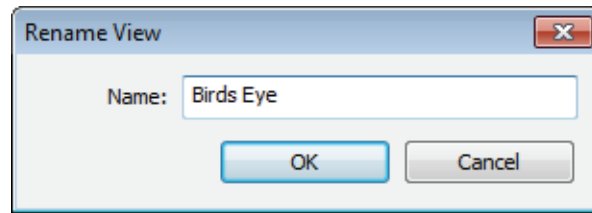



Figure 2–43

- When changes to the default 3D view are saved and you start another default 3D view, it displays the Southeast isometric view once again. If you modified the default 3D view but did not save it to a new name, the **Default 3D View** command opens the view in the last orientation you specified.

How to:

Create a Perspective View

1. Switch to a Floor Plan view.
2. In the Quick Access Toolbar or *View* tab>Create panel, expand  (Default 3D View) and click  (Camera).
3. Place the camera on the view.
4. Point the camera in the direction in which you want it to shoot by placing the target on the view, as shown in Figure 2–44.

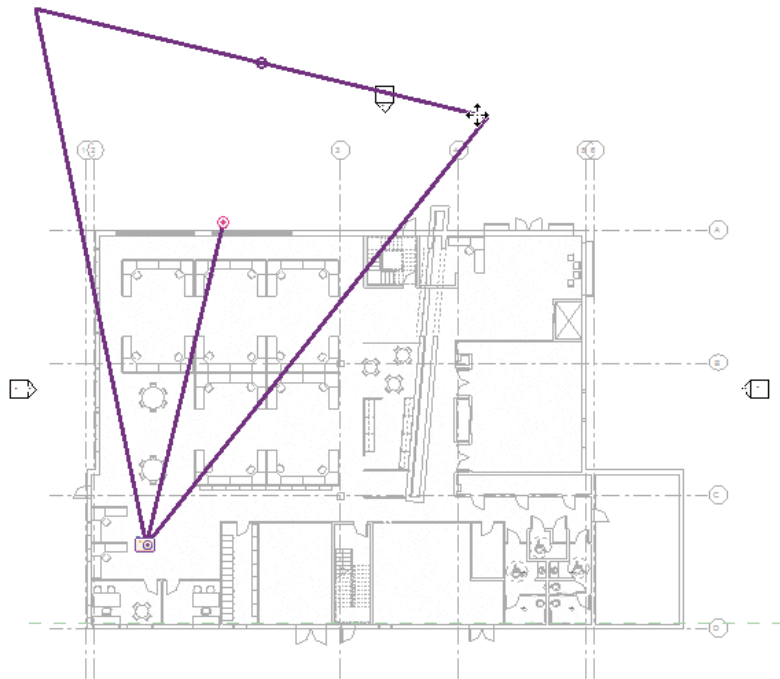

Figure 2–44

Use the round controls to modify the display size of the view and press <Shift> + the mouse wheel to change the view.

A new view is displayed, as shown in Figure 2–45.

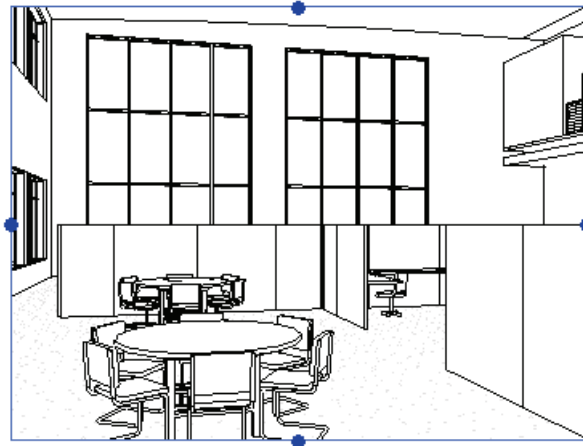

Figure 2–45

Visual Styles

Any view can have a visual style applied. The **Visual Style** options found in the View Control Bar (shown in Figure 2–46), specify the shading of the building model. These options apply to plan, elevation, section, and 3D views.

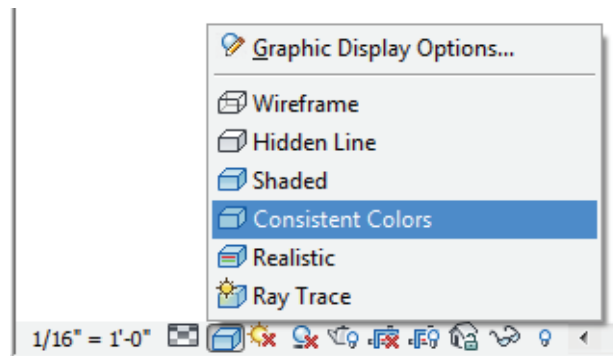

Figure 2–46

The **Shaded** and **Consistent Colors** visual styles give you a sense of the materials, including transparent glass, as shown in Figure 2–47.

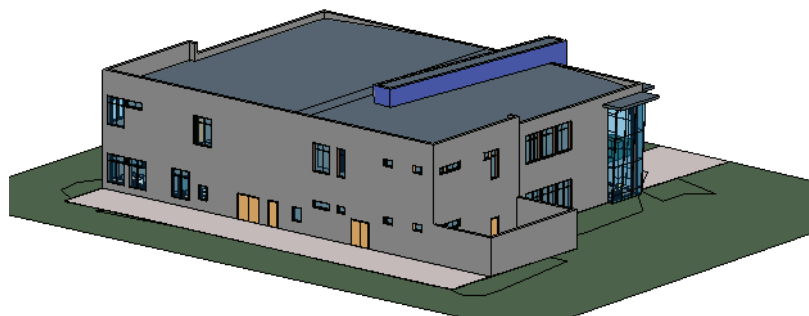

Figure 2–47



- The **Realistic** visual style displays what is displayed when you render the view. It takes a lot of computer power to execute this visual style; therefore, it is better to use the other visual styles most of the time as you are working.
- The **Ray Trace** visual style is useful if you have created a 3D view that you want to render. It gradually moves from draft resolution to photorealistic. You can stop the process at any time.

Hint: Using the ViewCube

The ViewCube provides visual clues as to where you are in a 3D view. It helps you move around the model with quick access to specific views (such as top, front, and right), as well as corner and directional views, as shown in Figure 2–48.

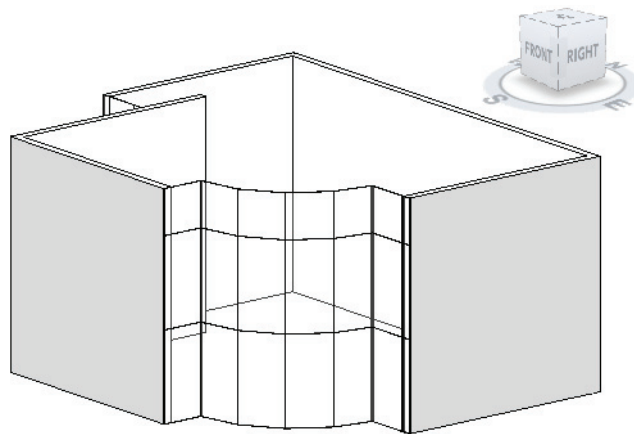



Figure 2–48

Move the cursor over any face of the ViewCube to highlight it. Once a face is highlighted, you can select it to reorient the model. You can also click and drag on the ViewCube to rotate the box, which rotates the model.

-  (Home) displays when you roll your cursor over the ViewCube. Click it to return to the view defined as **Home**. To change the Home view, set the view as you want it, right-click on the ViewCube, and select **Set Current View as Home**.
- The ViewCube is available in isometric and perspective views.

Practice 2a

Open and Review a Project



Navigate the graphic user interface.



Manipulate 2D and 3D views by zooming and panning.



Create 3D Isometric and Perspective views.



Set the Visual Style of a view.

Estimated time for completion: 15 minutes

In this practice you will open a project file and view each of the various areas in the interface. You will investigate elements, commands, and their options. You will also open views through the Project Browser and view the model in 3D, as shown in Figure 2–49.

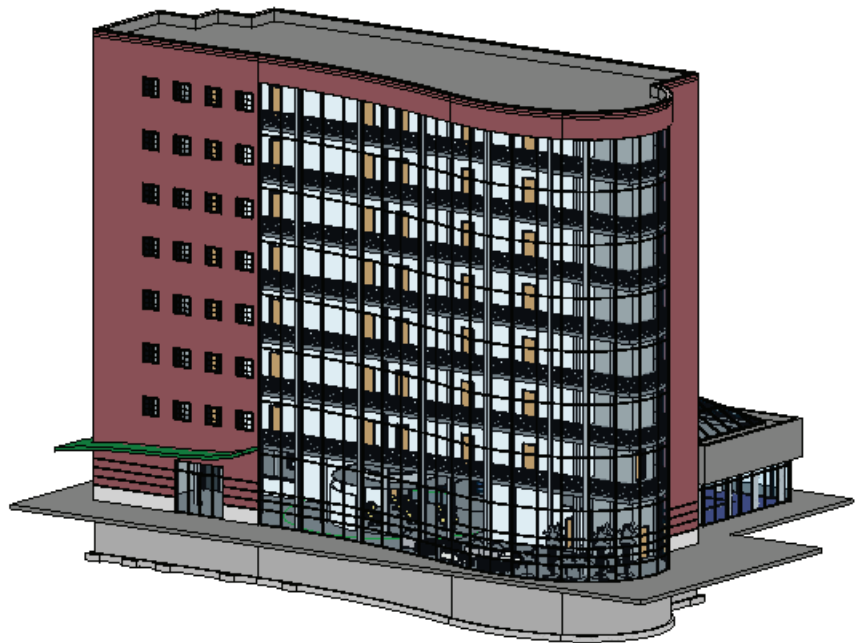

Figure 2–49

Task 1 - Explore the interface.

1. Open the project file **Modern-Hotel-Final.rvt**. It is found in your class directory and is a version of the main project you will work on throughout the course.
2. Take time to review the floor plan to get acquainted with it.

3. Review the various parts of the screen.
4. In the drawing window, hover your cursor over one of the doors. A tooltip displays describing the element, as shown in Figure 2–50.

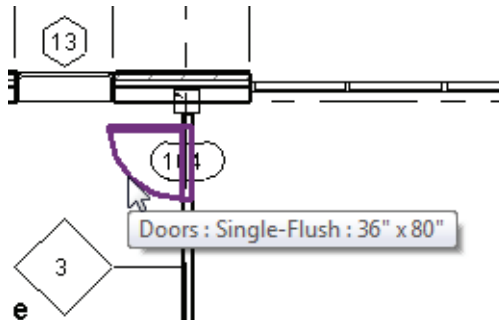





Figure 2–50

5. Hover the cursor over another element to display its description.
6. Select a door. The Ribbon changes to the *Modify | Doors* tab.
7. Click in an empty space to release the selection set.
8. Hold down <Ctrl> and select several elements of different types. The Ribbon changes to the *Modify | Multi-Select* tab.
9. Click in an empty space to release the selection set.
10. In the *Home* tab>*Build* panel, click  (Wall). The Ribbon changes to the *Modify | Place Wall* tab and displays specific tools you can use to create walls at the end of the Ribbon tab. The rest of the Ribbon displays the same tools that are found on the *Modify* tab.
11. In the *Select* panel, click  (Modify) to return to the main Ribbon.
12. In the *Home* tab>*Build* panel, click  (Door). The Ribbon changes to the *Modify | Place Door* tab and displays the options and tools you can use to create doors.

You might need to widen the Project Browser to display the full names of the views.

Task 2 - Look at views.

1. In the Project Browser, expand the *Floor Plans* node. Double-click on the **1st Floor Furniture Plan** view.
2. The basic floor plan displays with the furniture but none of the annotations you saw in the other view. Open the **1st Floor Life Safety Plan** view.
3. The walls and furniture display, but the furniture is grayed out and red lines describing important life safety information display.
4. In the Project Browser, scroll down and expand *Elevations (Building Elevation)*. Double-click on the **East** elevation to open the view.
5. Expand *Sections (Building Section)* and double-click on the **East-West Building Section** to open it.
6. In the View Control Bar, click  (Visual Style) and select **Shaded**. The elements in the section are now easier to read.
7. In the Project Browser, scroll down to the *Sheets (all)* node.
8. View several of the sheets. Some have views already applied, such as the A4.1 Reflected Ceiling Plan shown in Figure 2–51.

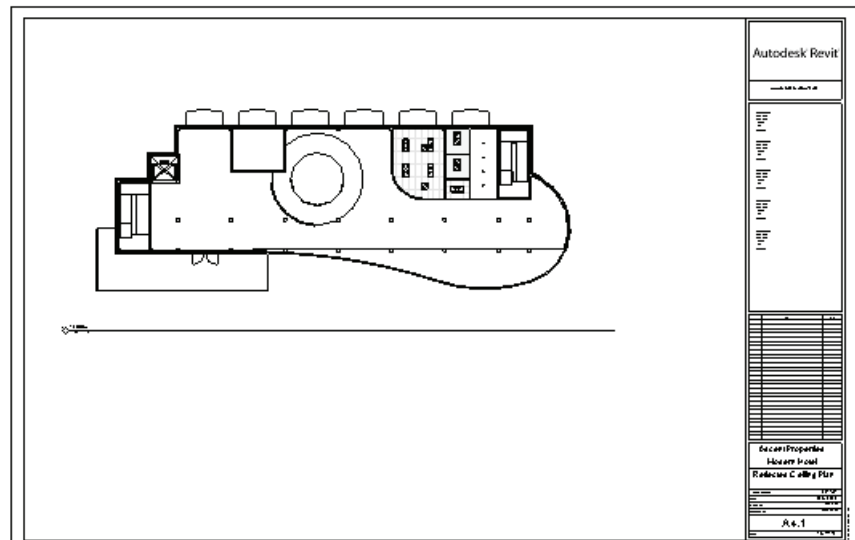



Figure 2–51

9. Which sheet shows the view that you just set to **Shaded**?

Task 3 - Practice viewing tools.

1. Return to the **Floor Plans: 1st Floor** view.
2. In the Navigation Bar, click  and select **Zoom In Region** or type **ZR** at the Command Line. Zoom in on one of the stairs.
3. Pan to another part of the building using the middle mouse button or wheel. Alternatively, you can use the 2D Wheel in the Navigation Bar.
4. Double-click on the mouse wheel to zoom out to fit the extents of the view.
5. In the Quick Access Toolbar, click  (3D View) to open the default 3D view, as shown in Figure 2–52.

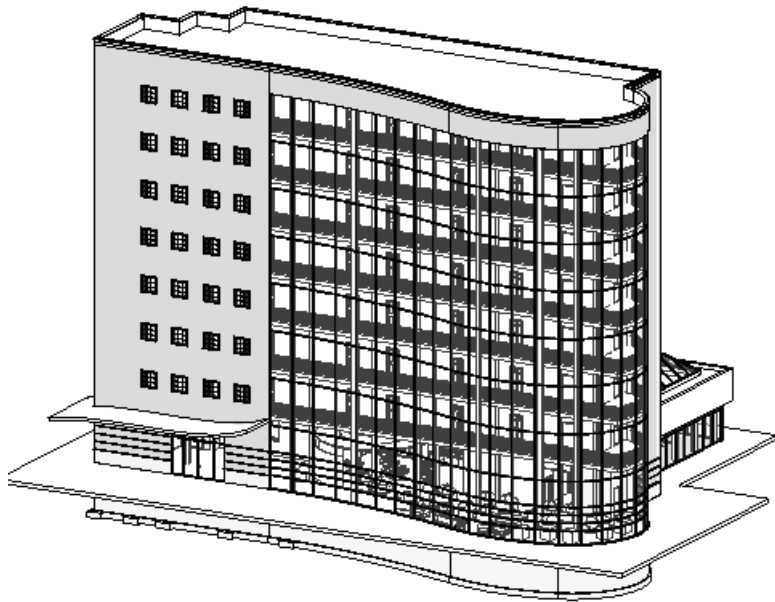





Figure 2–52

6. Hold down <Shift> and use the middle mouse button or wheel to rotate the view.
7. In the View Control Bar, change the *Visual Style* to  (Shaded). Then try  (Consistent Colors). Which one works best when you view the back of the building?
8. Use the ViewCube to find a view that you want to use.
9. In the Project Browser, expand *3D Views* and right-click on the {3D} view. Rename it.

10. Look at the two other 3D views that have already been created.
11. Return to the **Floor Plans: 1st Floor** view.
12. In the Quick Access Toolbar, expand  (Default 3D View) and click  (Camera).
13. Click the first point near the Lobby room name and click the second point outside the building, as shown in Figure 2–53.

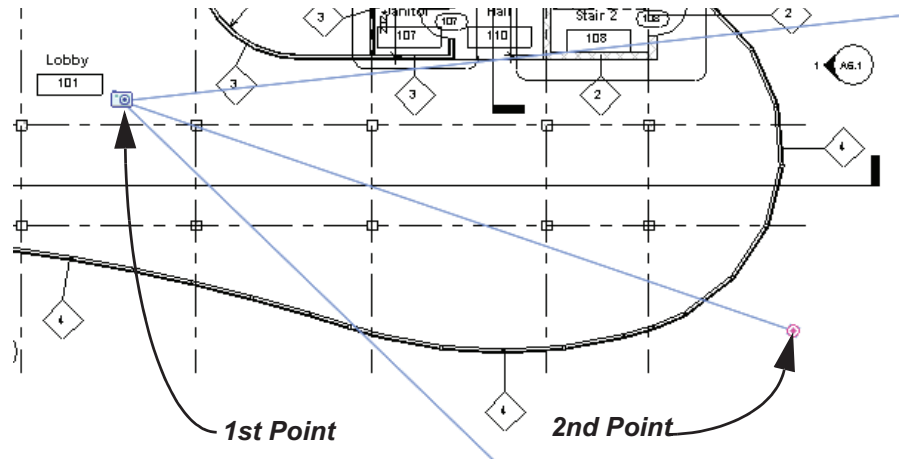





Figure 2–53















14. The furniture and planters display even though they did not display in the floor plan view.
15. Set the *Visual Style* to  (Realistic).
16. Save the view as **Lobby Seating Area**.
17. In the Quick Access Toolbar, click  (Save) to save the project.
18. In the Application Menu, select **Close**. This closes the entire project.







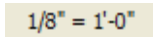

This file is not set up to work with Raytrace.

Chapter Review Questions

1. When you create a project in the Autodesk Revit software, do you draw in 2D or 3D?
2. What is the purpose of the Project Browser?
3. Which part of the interface changes according to the command you are in?
4. When you start a new project, how do you specify the base information in the new file?
5. What is the main difference between  (3D View) and a Camera view?

Command Summary

Button	Command	Location
	3D View	<ul style="list-style-type: none"> ■ Quick Access Toolbar ■ Ribbon: <i>View</i> tab>Create panel
	Camera	<ul style="list-style-type: none"> ■ Ribbon: <i>View</i> tab>Create panel>3D View>Camera
	Consistent Colors	<ul style="list-style-type: none"> ■ View Control Bar: Visual Style>Consistent Colors
	Door	<ul style="list-style-type: none"> ■ Ribbon: <i>Home</i> tab>Build panel ■ Shortcut: DR
	Hidden Line	<ul style="list-style-type: none"> ■ View Control Bar: Visual Style>Hidden Line ■ Shortcut: HL
	Home	<ul style="list-style-type: none"> ■ ViewCube
	Modify	<ul style="list-style-type: none"> ■ Quick Access Toolbar ■ Ribbon: <name of contextual> tab>Select panel ■ Shortcut: MD ■ Contextual Ribbon
	New	<ul style="list-style-type: none"> ■ Quick Access Toolbar (Optional) ■ Application Menu: New>Project ■ Shortcut: <Ctrl>+<N>
	Next Pan/Zoom	<ul style="list-style-type: none"> ■ Navigation Bar ■ Right-click Menu
	Open Documents	<ul style="list-style-type: none"> ■ Application Menu: Open Documents
	Previous Pan/Zoom	<ul style="list-style-type: none"> ■ Navigation Bar ■ Shortcut: ZP
	Ray Trace	<ul style="list-style-type: none"> ■ View Control Bar: Visual Style>Ray Trace
	Realistic	<ul style="list-style-type: none"> ■ View Control Bar: Visual Style>Realistic
	Recent Documents	<ul style="list-style-type: none"> ■ Application Menu: Recent Documents
	Save	<ul style="list-style-type: none"> ■ Quick Access Toolbar ■ Application Menu: Save ■ Shortcut: <Ctrl>+<S>
	Scale	<ul style="list-style-type: none"> ■ View Control Bar
	Synchronize Now/ Synchronize and Modify Settings	<ul style="list-style-type: none"> ■ Quick Access Toolbar

	Shaded	<ul style="list-style-type: none"> ■ View Control Bar: Visual Style> Shaded ■ Shortcut: SD
	Visual Style	<ul style="list-style-type: none"> ■ View Control Bar
	Wall	<ul style="list-style-type: none"> ■ Ribbon: <i>Home</i> tab>Build panel ■ Shortcut: WA
	Wireframe	<ul style="list-style-type: none"> ■ View Control Bar: Visual Style> Wireframe ■ Shortcut: WF
	Zoom All to Fit	<ul style="list-style-type: none"> ■ Navigation Bar ■ Shortcut: ZA
	Zoom In Region	<ul style="list-style-type: none"> ■ Navigation Bar ■ Shortcut: ZR
	Zoom Out 2x	<ul style="list-style-type: none"> ■ Navigation Bar ■ Shortcut: ZO
	Zoom Sheet Size	<ul style="list-style-type: none"> ■ Navigation Bar ■ Shortcut: ZS
	Zoom to Fit	<ul style="list-style-type: none"> ■ Navigation Bar ■ Shortcut: ZF or ZE