

**JUMP-N-CARRY®  
PRO 660**

- The most powerful jump starter on the market
- 1700 peak amps
- Weighs only 18 lbs.

**SUPER  
HOT DEAL!****\$149<sup>00</sup>**

#JNC660 (SLR)

**SOLAR****1/2" IMPACT WRENCH**

- 750 ft. lbs. of quiet power
- 1100ft. lbs. of breakaway torque
- One hand forward/reverse
- Quiet Tech™ exhaust system delivers 82 dBA
- Weighs only 4.3 lbs.

**\$179<sup>00</sup>**

#SX4345 (SUN)

**SUNEX  
TOOLS****New! 7"/9" VARIABLE  
SPEED POLISHER**

- 12.0 amp ball bearing motor
- Heat-treated precision cut gears
- Variable speed trigger to control speed from 0 to dialed maximum setting

**\$229<sup>00</sup>**

#DWP849 (DEW)

**DEWALT**  
High Performance Industrial Tools & Accessories**New! MULTI-PURPOSE  
ANGLE DIE GRINDER**

- Powerful motor delivers 0.25 HP (0.19 kW) at 21,000 rpm free speed
- Durable ball-bearing construction
- Strong aluminum housing
- Tool comes with 1/4" and 6 mm collets and two wrenches

**\$71<sup>50</sup>**

#301B (ING)

**IR** Ingersoll Rand**9000 WATT MOBILE  
GENERATOR W/ELECTRIC  
START**

- Powered by 15HP OHV forced air-cooled, 4 stroke engine
- Runs 8.5 hours @ 1/2 load
- Operating noise 76dB
- Outlets: (2) AC 120V, (1) 120V twist lock, (1) 120/240V twist lock, (1) 12V DC

**\$849<sup>00</sup>**

#GG900E (COL)

**New! PRESSURIZED  
WASTE OIL DRAIN**

- Large 20 gallon capacity
- Large 18" bowl
- Telescopic bowl ranges from 44 - 72"

**LINCOLN****\$525<sup>00</sup>**

#3614 (LIN)

**New! 120V  
PLASMA  
CUTTER W/AIR  
COMPRESSOR**

- 120 volts / 12 amps
- Easily cuts 1/8"
- Severs up to 1/4"
- Duty cycle: 25% @ 12 amps

**\$859<sup>00</sup>**

#00317 (FWP)

**FOTNEY  
INDUSTRIES, INC.****TOOL TALK**



# TABLE OF CONTENTS

A/C Recycling.....	1
Battery.....	4
Brake Lathe.....	20
Cleaning.....	9
Compressors/Air Line.....	7
Diagnostic/Test Equipment.....	10
Lifting.....	13
Lubrication.....	17
Paint & Body.....	21
Power Tools.....	23
Shop.....	29
Shop / Sandblast.....	34
Tire Service.....	20
Tool Storage.....	35
Welding.....	36

**New!**

## ADROIT-PRO DIGITAL BATTERY & SYSTEM TESTER

- 6 and 12 Volt Battery Testing
- Operating Range: 1.5V-15V
- Testing Capacity: 40-2000 CCA
- Tests Against Multiple Rating Systems



**\$255<sup>00</sup>**

#BA44 (SLR)

**SOLAR**

## STOCKING CODE



**= FACTORY SHIP**

Items designated with the icon will be shipped direct from the factory.



## PROFESSIONAL WORKSHOP VISE

- High quality construction for extra durability and full strength performance at any jaw opening
- 360 degree swivel base
- Machined base plate - smooth swivel
- "V" notches for vertical gripping, built in pipe jaws



**\$164<sup>00</sup>**

#64055 (KEN)

**Ken-Tool**

## PLASTIC LOW PROFILE JEEPERS CREEPERS®

- Body-fitting design
- Six, pop-in style 2" urethane wheels
- Low profile, 7/8" clearance
- Super rugged, one piece plastic body
- Resistant to solvents, grease & fuel



**\$75<sup>00</sup>**

#92102-BTB (LIS)

**Lisle**



## Sunex Tools **HOT** Deals!



### 3 TON CAPACITY SERVICE JACK

- A heavy duty jack that features extra wide front wheels
- Round saddle made from stamped steel
- Heavy gauge steel frame
- Heavy duty swivel rear casters



**\$195<sup>00</sup>**

#6603 (SUN)

### 3.5 TON SERVICE JACK w/QUICK LIFT

- 12 strokes or less to high height under load
- Dual piston power unit



**\$249<sup>00</sup>**

#66037 (SUN)

### 22 TON AIR/HYDRAULIC TRUCK JACK

- Low height 9"; raised height 17"
- Chrome plated lift arm
- Self-retracting ram springs
- Push valve lever
- 3 position lock lever



**\$599<sup>00</sup>**

#6622 (SUN)

### TWO-STAGE TELESCOPIC TRANSMISSION JACK

- 1000 lbs. capacity
- Low height 35.5" to high height 79.5"



**\$529<sup>00</sup>**

#7793B (SUN)

©2012 Parts Warehouse, Inc. its subsidiaries and affiliates do not manufacture any of the products listed in the ToolTalk Catalog. PWI disclaims any warranty under the ToolTalk catalog implied warranty of merchantability and fitness for a particular purpose and any responsibility for the content of each manufacturer's warranty. PWI reserves the right to limit quantities and to correct pricing errors and the right to substitute products of equal or greater value. Prices good at participating Bumper to Bumper Auto Parts stores. Errors in prices, descriptions, and/or illustrations of them are not the responsibility of Parts Warehouse, Inc., its agencies or affiliates. Some items may require special order.



## STANDARD SIDE WHEEL MANIFOLD SET

R-12 manifold gauge set with three color coded hoses and fittings

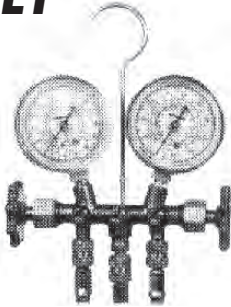

**87<sup>00</sup>**  
with 36" hoses  
#40153 (ROB)

**ROBINAIR**

## R 134A MANIFOLD HOSE KIT

- Brass manifold with easy to-grip handles
- R12/R134a gauges, PSI, and °F temp
- 1/2" ACME bottom ports
- Rear R134A and 1/2" ACME fittings for holding hoses
- 90° manual couplers
- 72" R134A hose set



**170<sup>00</sup>**  
#45111 (ROB)

**ROBINAIR**

## SERVICE COUPLERS FOR R134A

- 18190A - Low side coupler, blue actuator
- 18191A - high side coupler, red actuator



**42<sup>19</sup> ea.**  
#18190A/18191A (ROB)

**ROBINAIR**

## UNIVERSAL REPLACEMENT GAUGES



**Compound Gauge** **Pressure Gauge**  
**23<sup>00</sup>** **23<sup>00</sup>**  
#11794 (ROB) #11795 (ROB)  
Replaces 11692 Replaces 11693

**ROBINAIR**

## THERMOMETERS

- Includes pocket-clip carrying case for protection & easy access
- Easy to read dial faces



**8<sup>45</sup>** **10<sup>35</sup>**  
#10597 - 1" (ROB) #10945 - 1 3/4" (ROB)

**ROBINAIR**

## AIR VAC R12-R134A

- Connect back fitting to compressed air source & front fitting to center hose of a standard manifold set attached to an A/C system
- Compressed air driven - no oil or moving parts



**67<sup>00</sup>**  
#34970 (ROB)

**ROBINAIR**

## VACUUM PUMP & GAUGE SET

- Set includes (1) #6909 3 cfm Vacuum Pump and (1) #6715B R134a Brass Manifold Gauge Set in Box



**179<sup>00</sup>**  
#9281 (FJC)

**FJC**  
Air Conditioning Products

**New**

## 5 CFM VACUUM PUMP

- Two-stage performance using Twin-Port Technology™
- Lightning fast design removes moisture & non-condensable gases
- Lightweight, durable construction for easy handling



**145<sup>00</sup>**  
#6912 (FJC)

**FJC**  
Air Conditioning Products

## SMART-CHARGE R-134a RECHARGE KIT

- Accurately measure & charge R-134a A/C systems
- Built-in temperature sensor
- Easy to read light indicator
- Trigger dispenser



**32<sup>88</sup>**  
#425 (FRE)

**QUEST**

## ELECTRONIC LEAK DETECTOR

- One hand operation
- Audible & visual leak indicators
- Threshold balancing control
- Volume control
- Reliable technology



**212<sup>00</sup>**

#16600 (ROB)

**ROBINAIR**

## HEATED PENTODE® REFRIGERANT DETECTOR

- Heated Pentode® sensor technology
- Tri-color visual leak size indication
- Detects all CFC, HFC, HCFC's including R-12, R-22, R-123, R-134A, R404A, R407A, R408A and R-410A
- Tactile keypad controls
- Rechargeable batteries



**299<sup>00</sup>**

TIFZX (ROB)

**ROBINAIR**

## CORDLESS/RECHARGEABLE TRUE UV LED LIGHT

- 12 LED's produce hi intensity true UV light
- UV enhancing glasses
- Battery charger included



**123<sup>00</sup>**

#16345 (ROB)

**ROBINAIR**

## COMPLETE UV LEAK DETECTION KIT

- Powerful 50 watt/12 volt UV lamp with cord and battery clips
- Injection gun, R-134a hose & R-12 adapter
- 4 universal A/C dye twist-on cartridges (#16351 enough dye for 20 applications)
- UV enhancing glasses w/dye cleaner



**199<sup>00</sup>**

#16350 (ROB)

**ROBINAIR**

## NEW UNIVERSAL A/C DYE

- Four 1 oz. twist-on replacement cartridges
- Enough dye for 20 applications
- OEM-approved and SAE certified dye
- Service stickers included



**58<sup>00/cs</sup>**

#16356 (ROB)

**ROBINAIR**

## DYE INJECTION KIT



- The best kit in UV leak detection.
- Injection gun with R-134a hose and R-12 adapter
- 4 universal A/C dye twist-on cartridge (#16356)... enough dye for 20 applications
- Service stickers

**117<sup>00</sup>**

#16355 (ROB)

**ROBINAIR**

## QUICK CHANGE FILTER

Fits 17400A, 17700A, 34400 & 34700 machines



**69<sup>00</sup>**

#34430 (ROB)

**ROBINAIR**

## SPIN-ON NEW STYLE FILTER

Fits 17700A, 34134A, 34700 1999 machines



**69<sup>00</sup>**

#34724 (ROB)

**ROBINAIR**

## PREMIUM HIGH VACUUM PUMP OILS

Engineered to maintain maximum viscosity at high running temperatures

Quart Bottle-  
**739**

#13203 (ROB)



Gallon Bottle-  
**2350**

#13204 (ROB)



**ROBINAIR**

## FIN STRAIGHTENER

- Handy six-in-one straightener cleans and straightens condenser and evaporator coil fins.
- Straightener sections are clearly marked for fin size.
- 8, 9, 10, 12, 14 and 15 fins per inch



**15<sup>99</sup>**

#18403 (ROB)

**ROBINAIR**

## COOL-TECH RECOVERY, RECYCLING, RECHARGING

- Combines simple operation with superior accuracy
- Recovers, recycles, evacuates, leak tests, & recharges R-134a quickly and accurately
- Semi-automatic function



**2,859<sup>00</sup>**

#34288 (ROB)

**ROBINAIR**

## COOL-TECH RECOVERY, RECYCLING, RECHARGING

- Combines simple operation with superior accuracy
- Recovers, recycles, evacuates, leak tests, & recharges R-134a quickly and accurately
- FULLY automatic function



**3,569<sup>00</sup>**

#34788 (ROB)

**ROBINAIR**

## PREMIUM A/C RECOVERY, RECYCLING, RECHARGING

- Fully-automatic function
- Automatic dye inject
- Automatic oil measure & inject
- A/C system flush
- Save & print before & after service data
- Indicator light & notification alarm



**4,249<sup>00</sup>**

#34988 (ROB)

**ROBINAIR**

## PRO-LOGIX BATTERY MAINTAINERS



**SOLAR**

- Automatic operation
- 6 and 12 Volt charging
- Compatible with multiple battery types including Conventional, AGM, Gel Cell, Spiral Wound, and Deep Cycle Batteries
- Smart Clamp Technology - Outputting current only when a proper battery connection has been made
- Multiple output options - includes clamp set (PLA51) and ring set (PLA52) (12V plug set available - PLA53)

**New** 6/12V, 1.0 amp

**50<sup>00</sup>**

#PL2110 (SLR)

6/12V, 3.5 amp

**71<sup>00</sup>**

#PL2135 (SLR)

## 1 AMP MANUAL PORTABLE CHARGER



- Warms average car battery overnight
- Motorcycle, garden tractor, snowmobile
- 1 amp 6/12 volt slow charge

**31<sup>00</sup>**

#1001 (SLR)

Reg. user \$44.29 **SOLAR**

## ON-BOARD BATTERY CHARGER

- Maintain 12 volt batteries without overcharging
- Fully automatic-LED charge status
- Can be permanently mounted



**37<sup>00</sup>**

#1002 (SLR)

Reg. user \$62.51 **SOLAR**



**New**

## 6/12V, 6/2 AMP SMART CHARGER



- 6 and 12 Volt Operation
- 6 amp high; 2 amp low charge rate
- Automatic operation
- Properly charges multiple battery types
- Smart clamp technology for ease and safety
- Polarity protection
- Soft start mode for deeply discharged batteries
- LED progress bar alert to charging progress
- Unique, lightweight design
- Integrated cable management

**40<sup>00</sup>**

#4506 (SLR)

**SOLAR**

**New**

## 12V, 12/6/2 AMP SMART CHARGER



- 12 Volt Operation
- 12 amp fast; 6 amp medium; 2 amp low charge rate
- Automatic operation
- Properly charges multiple battery types
- Smart clamp technology for ease and safety
- Polarity protection
- Soft start mode for deeply discharged batteries
- Digital display alerts to charging progress
- Unique, lightweight design
- Integrated cable management

**56<sup>00</sup>**

#4512 (SLR)

**SOLAR**

**New**

## 12V, 20/10/2 AMP SMART CHARGER



- 12 Volt Operation
- 20 amp fast; 10 amp medium; 2 amp low charge rate
- Automatic operation
- Properly charges multiple battery types
- Smart clamp technology for ease and safety
- Polarity protection
- Soft start mode for deeply discharged batteries
- Digital display alerts to charging progress
- Unique, lightweight design
- Integrated cable management

**67<sup>00</sup>**

#4520 (SLR)

**SOLAR**

**New**

## PRO-LOGIX BATTERY CHARGERS / MAINTAINERS



- 6 and 12 Volt battery charging
- Fully automatic operation
- Advanced multi-phase charging process
- Properly charges all battery types
- Soft Start Mode for severely depleted batteries
- Recondition Mode rejuvenates distressed batteries
- Enhanced maintenance mode for ideal long term storage
- Temperature compensation for more effective charging
- Reverse Polarity Protection and Battery Fault Detection
- Data rich display provides detailed feedback during charging

10/6/2 AMP

**75<sup>00</sup>**

#PL2310 (SLR)

20/10/2 AMP

**99<sup>00</sup>**

#PL2320 (SLR)

**SOLAR**

## BATTERY TESTER

- 100 amp load tester
- Tests batteries to 1000 CCA



**40<sup>00</sup>**

#1852 (SLR)

Reg. user \$58.29 **SOLAR**

## 10/2/55 MANUAL CHARGER/STARTER

- Powerful 55 amp UL rated engine start
- Color coded, full size ammeter
- 10 amp high, 2 amp low charge
- 10 amp 12 volt moderate charge



**75<sup>00</sup>**

#1050C (SLR)

Reg. user \$110.52 **SOLAR**

## 10/2/55 AUTO CHARGER/STARTER

- Powerful 55 amp UL rated engine start
- Automatic technology 12 volt
- Temperature compensated
- 6/12 volt charging



**99<sup>00</sup>**

#1060C (SLR)

Reg. user \$142.28 **SOLAR**

## 15/2/100 AUTO CHARGER/STARTER

- Powerful 100 amp UL rated engine start
- Automatic technology 12 volt
- 15 amp high, 2 amp low charge
- 6/12 volt charging



**150<sup>00</sup>**

#1160C (SLR)

Reg. user \$227.95 **SOLAR**

**New**

## 6/12V WHEELED BATTERY CHARGER

- 40 Amp 12V fast charge rate
- 20 Amp 12V medium charge rate
- 5 Amp 12V low charge rate
- 40 Amp 6V charge rate
- 200 Amp 12V engine starting assistance



**179<sup>00</sup>**

#4725 (SLR)

**SOLAR**

**New**

## INTELLIGENT WHEELED CHARGER w/ENGINE START

- 6/12 Volt
- 60/40/15/5A charge rates
- 275A of Engine Starting Assistance
- Fully automatic operation
- Properly charges all battery types



**418<sup>00</sup>**

#PL3730 (SLR)

**SOLAR**

**New**

## INTELLIGENT WHEELED CHARGER w/ENGINE START

- 6/12/24 Volt
- 60/40/15/5A charge rates
- 250A of Engine Starting Assistance
- Recondition Mode rejuvenates distressed batteries



**509<sup>00</sup>**

#PL3750 (SLR)

**SOLAR**

## DIGITAL BATTERY TESTER

- Quick 1-second initial results
- 125-1400 CCA range
- Analyze starting/charging system voltages
- Tests 12V batteries
- Temperature and low charge compensation
- Detects and identifies loose leads and bad cells



**159<sup>00</sup>**

#3183 (OTC)

Reg. user \$230.95

**SUPER HOT DEAL!**

**OTC**

## 6/12V DIGITAL VOLTMETER

- Operating range of 4.5-19.9 volts
- Features bright LED display



**26<sup>00</sup>**

#BA1 (SLR)

Reg. user \$36.35

**SOLAR**

## 12V BATTERY TESTER

- Operating range of 7-15 volts
- Capability to test batteries rated between 100-1200 cca
- Provides both a numerical and a pass/fail LED result



**67<sup>00</sup>**

#BA5 (SLR)

**SOLAR**

## 12V BATTERY & SYSTEM TESTER

- Same features as the BA5 with the added convenience of charging and starting system testing

**87<sup>00</sup>**

#BA7 (SLR)

**SOLAR**

**New**

## ADROIT-PRO DIGITAL BATTERY & SYSTEM TESTER

- 6 and 12 Volt Battery Testing
- Operating Range: 1.5V-15V
- Testing Capacity: 40-2000 CCA
- Tests Against Multiple Rating Systems
- 12 Volt Starting and Charging System Testing



**255<sup>00</sup>**

#BA44 (SLR)

**SOLAR**

**New**

## DIGITAL BATTERY & SYSTEM TESTER w/INTEGRATED PRINTER

- Complete testing solution for 6 and 12 Volt batteries and 12 and 24 Volt charging systems
- 1.5-30V Operating range
- 40-2000 CCA Testing capacity
- Integrated printer



**539<sup>00</sup>**

#BA327 (SLR)

**SOLAR**

**New**

## 12 VOLT COMMERCIAL STARTER/CHARGER w/AIR COMPRESSOR

- Automatic 10 Amp battery charger
- Jump starting based on battery installed
- 150 PSI air compressor with automatic shut-off switch
- 5' Retractable Jumper Cable leads
- Requires Group 31 battery (not included)



**SOLAR**

**1,339<sup>00</sup>**

#3001 (SLR)

**New**

## HEAVY TRUCK 12/24 VOLT COMMERCIAL CHARGER/STARTER

- Automatic 10 Amp Battery Charger
- 1400 cold cranking amps in 12 Volt mode
- 800 cold cranking amp in 24 Volt mode
- 10' Jumper Cable Leads
- Ships with (2) Group 31 Batteries



**SOLAR**

**1,699<sup>00</sup>**

#HT1224 (SLR)

## 12-VOLT ULTRA-PORTABLE JUMP STARTER

- Store anywhere, take anywhere unit
- 900 peak amps
- Weighs just 9 lbs.
- Features a flashlight, 12v outlet and full size clamps



**82<sup>00</sup>**

#JNC300XL (SLR)  
Reg. user \$112.50

**SOLAR**

## 12-VOLT BOOSTER PAC

- 900 peak amps
- 17 ampere-hour battery
- 1/2 amp charger included

**149<sup>50</sup>**

#ES2500 (SLR)  
Reg. user \$231.20



## SOLAR HD 12V BOOSTER PAC

- 1500 peak amps
- 1 amp charger included
- Super power Genesis Battery

**199<sup>00</sup>**

#ES5000 (SLR)  
Reg. user \$306.43

## TRUCK PAC HD JUMP STARTER

- 3000 peak amps
- (2) 22 amp hour batteries
- LED battery status indicator
- Automatic recharging
- 54" heavy-duty cable
- Industrial grade, Hot Jaw™ clamps
- DC outlet to power a variety of 12 Volt accessories
- 1 year limited warranty



**349<sup>00</sup>**

#ES6000 (SLR)  
Reg. user \$581.52 **SOLAR**

## JUMP-N-CARRY® 4000

- 1100 peak amps
- High impact ABS plastic case
- Features the Proformer Battery



**159<sup>00</sup>**

#JNC4000 (SLR)  
Reg. user \$229.81

**Jump-N-Carry®**  
The Professional's Choice

## JUMP-N-CARRY® PRO 660

- The most powerful jump starter on the market
- 1700 peak amps
- Weighs only 18 lbs.

**SUPER HOT DEAL!**  
**149<sup>00</sup>**

#JNC660 (SLR)  
Reg. user \$317.77



**Jump-N-Carry®**  
The Professional's Choice

## JUMP-N-CARRY® 1224

- Choice between 12 & 24 volt power
- 3000 peak amps @ 12 volt
- 1700 peak amps @ 24 volt

**569<sup>00</sup>**

#JNC1224 (SLR)  
Reg. user \$842.61



**Jump-N-Carry®**  
The Professional's Choice



## SOLAR OBD II MEMORY SAVER CONNECTOR

- Interface connector between a jump starter and vehicle's OBD II port
- Turns any jump starter with a 12V power port into a memory saver



**16<sup>75</sup>**

#ESA30 (SLR)

**SOLAR**

## SOLAR POWER INVERTERS

Stable, clean and reliable power with high surge capacity for use in powering a wide variety of electronics, appliances and power tools!



#PI1500X (SLR)  
150 Watt

**38<sup>50</sup>**

Reg. user \$54.38



#PI5000X (SLR)  
500 Watt

**84<sup>50</sup>**

Reg. user \$122.48



#PI10000X (SLR)  
1,000 Watt

**175<sup>00</sup>**

Reg. user \$258.89



#PI15000X (SLR)  
1,500 Watt

**299<sup>00</sup>**

Reg. user \$457.38

#PI20000X (SLR)  
2,000 Watt

**339<sup>00</sup>**

Reg. user \$500.84

#PI30000X (SLR)  
3,000 Watt

**595<sup>00</sup>**

Reg. user \$1,190.68



# COMPRESSOR/AIR LINE

## PREMIUM SERIES DIRECT DRIVE, ELECTRIC



**469<sup>00</sup>**

#PP1982012 (COL)

## PREMIUM PLUS SERIES OIL LUBRICATED, BELT DRIVE



**27 Gallon!**

**619<sup>00</sup>**

#IL1982713 (COL)

Model No.	Running HP	Voltage/ Amps	CFM @40 PSI	CFM @90 PSI	Tank Size (gallons)	Tank Style	Working Pressure	No. of Cylinders	Certified	Weight (lbs.)	Limited Warranty
PP1982012	1.9	120/15	7.7	6.0	20 ASME	Horz./Port.	95 -125 PSI	1	UL & CSA	113	1 year
IL1982713	1.9	120/240/15	7.1	5.7	27 ASME	Vert./Port.	100-130 PSI	2	UL & CSA	148	2 years

## CONTRACTOR® SERIES OIL LUBRICATED, BELT DRIVE



- Long lasting twin cylinder pump
- Twin wheelbarrow tank design
- Low profile handle design w/grips

**935<sup>00</sup>**

#CT-5590816.02 (COL)

**With 5.5HP Honda Engine**

**1,159<sup>00</sup>**

#CT-5590816 (COL)



Model No.	Engine HP	Engine Type	CFM @40 PSI	CFM @90 PSI	Tank Size (gallons)	Tank Style	Working Pressure	No. of Cylinders	Weight (lbs.)	Limited Warranty
CT-5590816.02	6.0	Subaru	10.9	8.9	8	Wheelbarrow	100-130 PSI	2	151	2years
CT-5590816	5.5	Honda	10.9	8.9	8	Wheelbarrow	100-130 PSI	2	151	2years

## 10HP 230V 3 PHASE ADVANTAGE

- 120 gallon tank
- 10 HP motor
- 34.8 CFM @ 175 PSIG
- Mounted mag starter
- Auto tank drain
- Air cooled aftercooler
- 5-year warranty



**CHAMPION**  
A Gardner Denver Product

**4,669<sup>00</sup>** **F S**  
#HR10-12 (CAC)



## 5HP 230V 1 PHASE AIR COMPRESSORS

- 80 gallon tank capacity
- 5 HP motor
- 16.5 CFM @ 175 PSIG
- Mounted mag starter
- Available in horizontal or vertical
- 5-year warranty

**2,599<sup>00</sup>**

Horizontal  
#HR5-8 (CAC) **F S**

Vertical - shown  
#VR5-8 (CAC) **F S**

**CHAMPION**  
A Gardner Denver Product

## ELECTRIC DRIVEN AIR COMPRESSOR

- External 5 HP 230V one phase
- 80-Gallon vertical receiver
- Delivers 16.0 CFM @ 175 PSI
- 2-stage, 2 cylinder pump
- Cast iron pump



**CHAMPION**  
A Gardner Denver Product

**1,729<sup>00</sup>** **F S**  
#5V80E1 (CAC)

## 5HP 230V 1 PHASE AIR COMPRESSORS

- 60 Gallon ASME tank
- 5 HP motor @ 3450 RPM
- 16.5 CFM @ 175 PSIG
- Available in vertical or horizontal
- 2-year warranty

**1,699<sup>00</sup>**

Horizontal  
#HRV5-6 (CAC) **F S**

Vertical  
#VRV5-6 (CAC) **F S**

(vertical unit shown)



**CHAMPION**  
A Gardner Denver Product

## 7.5HP 230V 1 PHASE ADVANTAGE

- Mounted mag starter
- 7.5 HP
- 23.5 CFM @ 175 PSI
- Auto tank drain
- Low oil level monitor
- Vibration isolators
- Air cooled aftercooler
- 5-year warranty

**3,069<sup>00</sup>**

#VR7F-8 (CAC) **F S**



**CHAMPION**  
A Gardner Denver Product

## GAS POWERED

- 13HP electric start, Kohler engine
- 23:2 CFM @ 175 PSIG
- 30 gallon ASME horizontal tank



**CHAMPION**  
A Gardner Denver Product

**2,399<sup>00</sup>**  
#HGR7-3K (CAC) (shown)

With 11hp Honda Engine  
**2,699<sup>00</sup>**  
#HGR5-3H (CAC)

## DUPLEX AIR COMPRESSOR

- (2) 5 HP 1 Phase Electric Motors
- (2) Two Stage Pumps
- Mounted on 80 gallon tank
- Total air delivery 33 CFM @ 175 PSI
- Automatic alternation
- 5 Year Warranty on motors & pumps
- Factory assembled - Plug and Play!

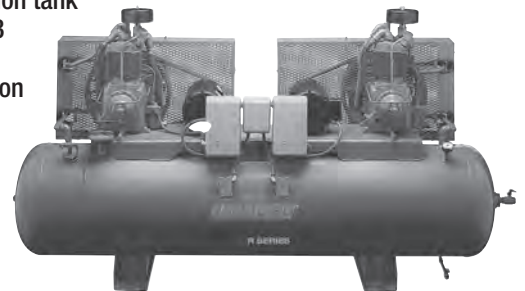

**CHAMPION**  
A Gardner Denver Product

**5,149<sup>00</sup>** **F S**  
#HR5D-8 (CAC)



## SHOP-VAC BULL DOG®

- 4 gallon tank; 2.0 peak HP
- Includes 1-1/4" Dia. x 10' hose, round brush, crevice tool & gulper nozzle tool holder
- Included filters: foam sleeve, reusable disc
- 3-year limited warranty



shop-vac  
The Original wet/dry vac

**61<sup>95</sup>**

#585-03-00 (SHV)

## SHOP-VAC BULL DOG®

- 8 gallon tank; 4.5 peak HP
- Complete with 12' lock-on hose, (2) extension wands, 10" combination nozzle, squeegee insert, round brush, crevice tool, gulper nozzle, cartridge filter
- 3-year limited warranty



shop-vac  
The Original wet/dry vac

**99<sup>95</sup>**

#587-08-00 (SHV)

## SHOP-VAC BULL DOG®

- 12 gallon tank; 6.5 peak HP
- Complete with 12' lock-on hose, (2) extension wands, 12" floor nozzle with brush, squeegee insert, crevice tool, claw utility nozzle, ultra web filter
- 20 ft. cord, tank drain blower feature
- 1-year limited warranty



shop-vac  
The Original wet/dry vac

**154<sup>00</sup>**

#962-12-10 (SHV)

**New**

## 2600 PSI PRESSURE WASHER

- 2.3 GPM
- 160cc Honda GC160 OHV engine
- Dolly style configuration for maneuverability
- 9" pneumatic tires
- 25' x 1/4" high pressure hose



**499<sup>00</sup>**

#PWFC132600.04 (COL)

## 3000 PSI PORTABLE PRESSURE WASHER

- 212CC magna force OHV engine
- 2.8 GPM max water flow
- 25' x 1/4" durable high pressure hose
- Axial style pump with brass manifold
- On-board 1 gallon soap storage tank



**429<sup>00</sup>**

#PWF0123000.01 (COL)

## ELECTRIC MOBILE PRESSURE WASHER



- Stainless steel tank shell
- Float tank with lid
- Stainless steel pump and motor console
- Belt driven triplex oil bath plunger pumps
- Low water burner protection
- Pressure relief valve
- Adjustable soap control
- Four wheel pneumatic tires

Model	Motor	Volt	PSI	GPM
216 RS	2.3 hp	115/1	1600	2.0
420 RS	5.0 hp	230/1	2000	3.8
530 R	10.0 hp	230/3	3000	5.0

**2,629<sup>00</sup>**

#216RS (WHI)  
Reg. user \$3,709.00

**3,399<sup>00</sup>**

#420RS (WHI)  
Reg. user \$4,829.00

**4,899<sup>00</sup>**

#530R (WHI)  
Reg. user \$7,019.00

## FUEL PRESSURE TESTER KIT

- Safely test vehicle fuel pressure systems
- Large, easy-to-read 1-100 PSI scale
- Pressure relief valve for safe, clean testing



**44<sup>00</sup>**

#CP7818 (SNT)  
Reg. user \$56.99

**Sunpro**

## MASTER FUEL INJECTION TEST KIT

- Checks fuel pressure on most PFI and TBI systems
- Adapts to work with test port, end of hose and in-line connections
- Test GM, Ford, Chrysler, Honda and Toyota



**299<sup>00</sup>**

#55700 (LIS)

**Lisle**

## DELUXE NOID LITE SET



- Quickly and easily tests electronic fuel injection systems on GM TBI, Bosch PFI, Ford TBI, GM PFI, Geo TBI & GM SCPI equipped vehicles
- Sturdy blow molded plastic storage case with extra tray

**15<sup>50</sup>**

#W89500 (WIL)

**Performance Tool**

## INDUCTIVE TIMING LIGHT

- On/off touch control
- All metal inductive pickup
- Super bright Xenon flash
- One touch control
- Durable, plated ABS housing
- Heat resistant over molding on battery clips
- One year warranty



**46<sup>00</sup>**

#CP7527 (SNT)  
Reg. user \$58.99

**Sunpro**

## ADVANCE INDUCTIVE TIMING LIGHT

- All of the features of the CP7527 plus adjustable knob measures centrifugal, vacuum and computer advance



**80<sup>00</sup>**

#CP7528 (SNT)  
Reg. user \$102.99

**Sunpro**

## STEM COMPRESSION TESTER

- 0-300 PSI
- 0-2100 Kilopascal scale
- Universal rubber adapter
- Handy push-in design



**20<sup>00</sup>**

#CP7821 (SNT)  
Reg. user \$24.99

**Sunpro**

## COMPRESSION TESTER KIT

- 14mm & 18mm ends fit most opening
- 14" flex hose
- Quick release oil & grease resistant hose



**33<sup>00</sup>**

#CP7827 (SNT)  
Reg. user \$41.99

**Sunpro**

## DIGITAL DIESEL COMPRESSION TEST KIT

**212<sup>00</sup>**

#MV535 (LIN)

**mityvac**

- Stores maximum compression value for up to 12 cylinders
- Backlit LC display
- Uses standard 9V battery
- Rubber boot protects gauge
- Sealed, grease-and oil-resistant gauge face
- Displays values in PSI, Bar and kPa



## DIGITAL MULTITESTER

- Lg. digital display
- Color coded leads
- Battery operated
- Computer safe



**39<sup>00</sup>**

#CP7674 (SNT)  
Reg. user \$48.99

**Sunpro**



## POCKET ELECTRICAL TESTER

- Tests volts, ohms, amps, decibels & batteries
- Analyzes a wide variety of electrical malfunctions
- Fuse protection on all functions & ranges
- Rotary function switch
- Easy-to-read mirrored scale



**17<sup>00</sup>**

#CP7848 (SNT)  
Reg. user \$20.99



**New**

## 2012 TIRE PRESSURE MONITOR MASTER KIT



- Base Kit comes with CD containing all reset procedure manuals
- Master Kit - same as base kit w/digital tire pressure gauge, 4-way valve tool, valve core torque driver & TPM electronic torque wrench

Base Kit

**469<sup>00</sup>**

#3833B12 (OTC)



Master Kit

**609<sup>00</sup>**

#3833M12 (OTC)

## LEAK TAMER PLUS EVAP

- Helps technicians diagnose EVAP trouble codes
- Uses UltraTraceUV™ technology
- Works with nitrogen, or shop air



**939<sup>00</sup>**

#6521 (OTC)



## CODESCOUT™ 2500 BILINGUAL OBD I & OBD II READER

- OBD I/OBD II code reader
- Software updateable via internet (software sold separately)
- Retain the most recently scanned vehicle's data and configuration
- OBD II code library built-in
- Dual language tool... English and Spanish
- Export data to a PC (software sold separately)
- Battery powered



**199<sup>95</sup>**

#2500 (AUX)



## OBD II POCKETSCAN®

- Compatible with 1996 and newer import & domestic vehicles as well as '94 & '95 OBD II compliant vehicles
- Reads/Erases codes
- Displays emissions & MIL status
- Indicates number of codes pulled
- OBD II cable (attached), & manual included



**75<sup>00</sup>**

#CP9125 (SNT)  
Reg. user \$135.99



## POCKETSCAN® PLUS

- Read and erase codes
- Display OBD II code definitions on screen
- Compatible w/all 1996 & newer vehicles
- Backlit display
- Provides visual indication when the tool is trying to communicate & retrieve data from an OBD II vehicle



**98<sup>00</sup>**

#CP9550 (SNT)  
Reg. user \$124.99



## OBD II AUTOSCANNER

- Read & display live data
- Display OBD II enhanced code definitions
- Display generic trouble code definitions
- Compatible w/all 1996 & newer vehicles (OBD II)
- Read & display MIL status, I/M monitors, freeze frame data
- Tri-lingual
- USB updateable



**145<sup>00</sup>**

#CP9575 (SNT)  
Reg. user \$186.99



**New**

## OBD II AUTOSCANNER PLUS

- Code assist - 4.3 million fixes
- Display, record & playback LIVE datastream
- LIVE real-time data
- ABS code read/erase
- Display enhanced code definitions
- Read & display VIN, CVN, Cal ID, IPT
- Optional battery power
- Asian ABS



**258<sup>00</sup>**

#CP9580A (SNT)



## ELITE AUTOSCANNER PRO

- OBD II enhanced codes (1996 and newer domestic vehicles) DTC Lookup Services for further help
- Graph data (1996 and newer)
- Multilingual menu & options
- Read, record & playback live sensor data
- OBD I functionality – cables included for '84 -'95 Ford, '84 -'95 GM and '89 -'95 Chrysler vehicles



**399<sup>00</sup>**

#CP9190 (SNT)  
Reg. user \$848.99



## GENISYS EVO® USA 2011 DELUXE w/HEAVY DUTY STANDARD KIT

- Includes Genisys EVO® featuring the New System 5.0 with Code-Assist™ experienced-based Confirmed Fixes™ from Identifix®, NEW USA 2011 Domestic/Asian with ABS and European 2010 software including Pathfinder, Repair-Trac®, Fast Fixes™ information, Heavy-Duty Standard software with cables, InfoTech Component Information software, Automated System Test™, OBD II Smart Cable, USA Domestic OEM vehicle cables (for GM, Ford, Chrysler, Jeep, Saturn), manuals, & carrying case.



**2,799<sup>00</sup>**  
#3874HD (OTC)

**GENISYS EVO® USA 2011 KIT w/DOMESTIC & ABS/AIR BAG CABLES**  
**2,099<sup>00</sup>**  
#3874 (OTC)



**GENISYS EVO® USA 2011 KIT w/TIRE PRESSURE RESET TOOL**  
**2,379<sup>00</sup>**  
#3874TPR (OTC)

## GENISYS SYSTEM 5.0 MEMORY EXPANSION KIT

- The memory card is pre-loaded for your convenience with all Genisys application software.



**239<sup>00</sup>**  
#3421-138 (OTC)



## GENISYS HEAVY DUTY STANDARD STARTER KIT

**619<sup>00</sup>**  
#3421-79 (OTC)  
Reg. user \$995.95



## GENISYS EVO® USA 2011 OBD II KIT

- Includes Genisys EVO® featuring the NEW System 5.0 with Code-Assist™ experienced-based Confirmed Fixes™ from Identifix®, NEW USA 2011 Domestic/Asian with ABS and European 2010 software including Pathfinder, Repair-Trac®, Fast Fixes™ information, InfoTech Component Information software, Automated System Test™, OBD II Smart Cable, manuals, and carrying case.



**1,449<sup>00</sup>**  
#3875 (OTC)

## USA 2011 DOMESTIC/ASIAN w/ABS SOFTWARE BUNDLE KIT

- NEW Domestic 2011 model coverage for GM, Ford, Chrysler, Jeep & Saturn with Asian coverage for Toyota, Honda, Nissan, Mazda, Mitsubishi & more!



System 4.0, 4GB Card Required to Install, see 3421-138.

**629<sup>00</sup>**  
#3421-135 (OTC)



**775<sup>00</sup>**  
#3421-136 (OTC)

Same as 3421-135 above with System 4.0 4GB Memory Card

## GENISYS 2011 SUPER BUNDLE PRODUCTIVITY KIT

- This powerful kit maximizes technician productivity with the 4 most popular Genisys™ options at a value price

**979<sup>00</sup>**  
#3421-137 (OTC)



## PEGISYS DIAGNOSTIC SYSTEM TRADE-IN KIT

### Handset Version

- USA Domestic/Asian vehicle subscription (6 months)
- Scan diagnostic (Pathfinder), scope diagnostic (InfoTech), Repair-Trac Experienced-Based information
- Direct-hit technician 90 day test drive subscription (3825-54)
- J2534 reprogramming 3825-08 kit
- OBDII cable, USA Domestic OEM OBSI cables, USA/Asian OEM OBD I cables, USB cable
- Scope accessory kit
- Carrying case, OEM OBD I cable
- AirBridge™ wireless kit
- 100-240 volt power supply



Comes with coupon for 6-Month Extension to Domestic/Asian software updates and 3825-01 Euro Starter Kit with trade-in of any professional diagnostic scan tool!

**4,299<sup>00</sup>**  
#3825JT (OTC)  
Reg. user \$9999.99



## HEAVY DUTY READER

- Class 4-8 truck coverage
- HD J1587/J1708 & J1939 CAN, engine, transmission ABS coverage and more for diagnostic trouble codes
- Read and clear diagnostic trouble codes
- Internet update capable

**469<sup>00</sup>**  
#3418 (OTC)





## 5-DRAWER ROAD CHEST

- Neoprene seal
- Powder coat black paint
- Full length drawer
- Heavy duty slides



**579<sup>00</sup>**

ZRT2605BK (INT)

Dimensions:

Overall	Width	Depth	Height
	26"	17 1/2"	22"
3 Drawers	23"	16"	25"
2 Drawers	23"	16"	41"

## METAL TOOL STORAGE

- Full length piano hinge
- Full size tray
- HD latches & handles
- Powder coat paint



**77<sup>00</sup>**

HBP2103 (INT)

3 Drawer

21"W x 8 3/4"D x 12"H



**63<sup>00</sup>**

HBB2100 (INT)

21"W x 8 3/4"D x 9"H



**39<sup>00</sup>**

HBB1900 (INT)

19"W x 6"D x 6 1/2"H



**79<sup>00</sup>**

HBB2600 (INT)

26"W x 8 3/4"D x 9"H

## ECONOMY 5 DRAWER TOP CHEST

**259<sup>00</sup>**

EFT2605 (INT)

## ECONOMY 3 DRAWER ROLLER CABINET

**299<sup>00</sup>**

EFT2703 (INT)



Available in Red

- Great starter tool storage system
- Powder coat paint
- 3"x1" casters

	Width	Depth	Height
EFT2605	26"	12"	14 1/2"
ETB2703	27"	17 1/4"	30"

## 10 DRAWER TOP CHEST

**329<sup>00</sup>**

CFT2610 (INT)

## 5 DRAWER ROLLER CABINET

**425<sup>00</sup>**

CFB2705 (INT)



Available in Red Only

- Holds up to 150 lbs. per drawer
- Powder coat paint
- Heavy duty 5"x1 1/4" casters
- 1600 lb. capacity

	Width	Depth	Height
CFT2610	26"	12"	18 7/8"
CFB2705	27"	18 3/4"	35 5/8"

## 20" DIAMOND BACK TOOL BOX

- Heavy-Duty
- Removable inner tray
- Strong double latch with padlock eyehole



**33<sup>50</sup>**

W54020 (WIL)



**26"  
40<sup>50</sup>**

W54026 (WIL)



## 11 DRAWER TOP CHEST

**639<sup>00</sup>**

CFT4211 (INT)

## 16 DRAWER ROLLER CABINET

**949<sup>00</sup>**

CFB4216 (INT)



Available in Red

- Holds up to 150 lbs. per drawer
- Powder coat paint
- Heavy duty 5"x2" casters
- 2000 lb. capacity

	Width	Depth	Height
CFT4211	40 1/2"	17 7/8"	20 1/2"
CFB4216	41 1/2"	18 3/4"	42 3/8"

## 2 POST ASYMMETRIC LIFT

- Surface mounted, frame contact lift
- Electro-hydraulic operation



**3,849<sup>00</sup>**



10,000 LB. CAPACITY

Please Call for  
Cost of Installation

#SPOA10 (ROT)

Reg. user \$5619.00

**revolution**

## 10,000 LB. CAPACITY LIFT

- Overhead padded switch bar
- Position vehicle doors in front or behind
- Top-mounted pull design hydraulic cylinder



**2,950<sup>00</sup>**



10,000 LB. CAPACITY

Please Call for  
Cost of Installation

#RTP10 (ROT)

Reg. user \$4598.00

**revolution**

## DELUXE HI-LIFT JACK

- Use as a winch, heavy equipment jack, fence stretcher and many more uses.



**89<sup>00</sup>**

#HL485 (HIL)

Reg. user \$139.95

**HI-LIFT**

## 1 TON CHAIN HOIST

- HD construction
- Heat treated bushings & bearings
- 8 ft. lift range



**83<sup>00</sup>**

W4005DB (WIL)

**Performance Tool**

## 1 TON POWER PULL

- 18:1 leverage
- 12 ft. lift
- 3/16" galvanized aircraft cable

**28<sup>00</sup>**

#18500 (AG)

## 2 TON POWER PULL (Not Shown)

- 36:1 leverage
- 6 ft. lift
- 3/16" galvanized aircraft cable

**32<sup>00</sup>**

#18600 (AG)

**AMERICAN POWER PULL**

## 1000 LB. ENGINE STAND

- 4-wheel design
- Rotates 360° & locks in 6 positions
- HD reinforced mounting head



**87<sup>00</sup>**

W41025 (WIL)

**Performance Tool**

## 750 LB. ENGINE STAND

- Sturdy tubular steel construction
- Multi-position locking mount
- T-shape design for added stability
- 4-wheel design



**107<sup>00</sup>**

#8750 (SUN)

Reg. user \$179.98

**SUNEX TOOLS**

## 20 TON CAPACITY TRUCK RAMPS (PR)



- Accepts tire widths up to 16"
- Designed to elevate front or rear of truck to gain access to frame
- Rubber surface base prevents slippage

**665<sup>00</sup>**

#1520 (SUN)

Reg. user \$1165.91

**SUNEX TOOLS**



## 20 TON SHORT BOTTLE JACK

- Low height 6.62"
- High height 11.87"
- Ductile iron base
- Electrostatic paint for rust prevention
- Hydraulic bypass system prevents over-extension of ram

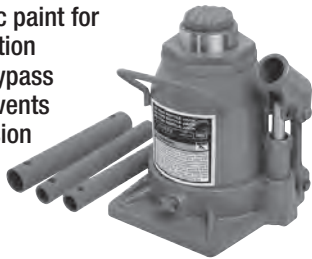

**91<sup>00</sup>**

#4923A (SUN)  
Reg. user \$146.04



## HYDRAULIC BOTTLE JACKS

- Electrostatically painted to prevent corrosion
- HD saddle for secure lifts
- Heat-treated, large diameter extension screw
- Hydraulic bypass prevents over-travel of ram
- Ductile steel base

### 2-T JACK

**23<sup>00</sup>**  
#4902A (SUN)  
Reg. user \$31.71

### 4-T JACK

**30<sup>69</sup>**  
#4904A (SUN)  
Reg. user \$41.65

### 8-T JACK

**50<sup>00</sup>**  
#4908A (SUN)  
Reg. user \$71.43

### 12-T JACK

**53<sup>50</sup>**  
#4912A (SUN)  
Reg. user \$85.71

### 6-T JACK

**36<sup>85</sup>**  
#4906A (SUN)  
Reg. user \$50.00

### 20-T JACK

**91<sup>00</sup>**  
#4920A (SUN)  
Reg. user \$145.82



## 20 TON AIR BOTTLE JACK

- Operates either manually or pneumatically
- Air hose swivels in any direction
- Safety valve prevents over-loading
- Raised height is 20.1"



**297<sup>00</sup>**

#4920CAH (SUN)  
Reg. user \$472.53



## 2 TON FOLDING ENGINE CRANE

- 4000 lb. capacity
- Adjustable boom with chain & hook
- Legs fold for easy storage
- Patented design



**289<sup>00</sup>**

#W41029 (WIL)



## 2 TON FOLDABLE ENGINE CRANE

- Fast rising
- 4.25" base provides easy access for low ground clearance
- Legs & boom can be folded to save space
- Chain & swivel hook
- Meets ASME PALD safety standards



**499<sup>00</sup>**

#5218 (SUN)  
Reg. user \$876.01



## RATCHETING JACK STANDS

- Square based frame
- Ductile steel column posts
- Self-lock ratchet stud

**3 TON**  
**42<sup>00</sup>** Pair

#1003 (SUN)  
Reg. user \$67.91

**6 TON**  
**67<sup>00</sup>** Pair

#1006 (SUN)  
Reg. user \$106.92



## 12 TON CAPACITY JACK STANDS

- Ductile steel column posts
- Self-lock ratchet stud
- Heavy duty welded base
- Saddle provides maximum load control

**169<sup>00</sup>**

#1012 (SUN)  
Reg. user \$269.69



## 22 TON CAPACITY JACK STANDS

- Flat base with telescopic tubes
- Modified V shaped saddle
- 22 ton capacity
- Low height 11.8"
- High height 19.7"

**177<sup>00</sup>**

#1522 (SUN)  
Reg. user \$288.90



## 1.5 TON SCISSOR JACK

- Lift range 4-15"
- Oversize base for stability and support
- Sturdy steel construction
- Meets or exceeds ASME PALD-2009 standards



**22<sup>00</sup>**

#W1600 (WIL)



## 3/4 TON ATV/MOTORCYCLE LIFT

- Foot activated pump & release pedals for hands free operation
- Meter control release pedal
- Non slip rubber pads protect vehicle frame
- Automatically adjusts to different lift heights
- 2 nylon tie downs included



**219<sup>00</sup>**

#6616 (SUN)

Reg. user \$357.03



## 1.5 TON RAPID LIFT ALUMINUM FLOOR JACK

- 3-5/8" to 17-1/2" lift range
- 47-3/4" cushion grip handle
- 3 pumps to maximum height
- 360° Swivel saddle with rubber cushion



**259<sup>00</sup>**

W1630 (WIL)



## 2 TON SERVICE JACK w/QUICK LIFT

- Lowest profile service jack in its class
- 12 strokes or less to high height when under load
- Dual piston power unit
- Safety overload system
- Foam handle bumper



**224<sup>00</sup>**

#6613A (SUN)

Reg. User \$378.79



## 2 TON LOW PROFILE JACK

- Great for cars & light duty trucks
- 2-3/4" to 20" lift range
- Dual pumps for faster lift
- Extended side flange
- Swivel casters
- Rubber saddle pad



**149<sup>00</sup>**

#W1642 (WIL)



## 3 TON CAPACITY SERVICE JACK

- A heavy duty jack that features extra wide front wheels
- Round saddle made from stamped steel
- Heavy gauge steel frame
- Heavy duty swivel rear casters



**195<sup>00</sup>**

#6603 (SUN)

Reg. User \$344.10



## 2 TON SERVICE JACK

- One piece handle
- Flanged side plates for increased strength
- U-joint release mechanism for precise load control
- Sealed hydraulic pump
- Pressure relief valve prevents overloading



**349<sup>00</sup>**

#HW93642 (HW)



## 3 TON SERVICE JACK

- Heavy duty frame for rugged applications
- Longer chassis ideal for Trucks and SUV's
- Breather plug assembly
- Sealed hydraulic pump
- Full swivel rear casters



**499<sup>00</sup>**

#HW93652 (HW)



## 3.5 TON SERVICE JACK w/QUICK LIFT

- 12 strokes or less to high height under load
- Dual piston power unit



**249<sup>00</sup>**

#66037 (SUN)

Reg. user \$491.03





## 5 TON SERVICE JACK

- Full swivel ball bearing rear casters
- Safety overload system
- Foot pedal operation
- Uniweld constructed hydraulic assembly
- Low lift 5"; High 22"



**719<sup>00</sup>**

#6604 (SUN)  
Reg. user \$1,231.76



## 10 TON SERVICE JACK

- Full swivel ball bearing rear casters
- Safety overload system
- Foot pedal operation
- Uniweld constructed hydraulic assembly
- Low lift 6.25"; High 22.5"



**959<sup>00</sup>**

#6609 (SUN)  
Reg. user \$1,651.82



## 22 TON AIR/HYDRAULIC TRUCK JACK

- Low height 9"; raised height 17"
- Chrome plated lift arm
- Self-retracting ram springs
- Push valve lever
- 3 position lock lever



**599<sup>00</sup>**

#6622 (SUN)  
Reg. user \$1,197.89



## 20 TON AIR/HYDRAULIC TRUCK JACK

- 20 ton @ 100 psi
- Low height 8.661"; raised height w/adaptor 23.35"
- Narrow chassis design
- 5" diameter composite wheels
- Self-retracting ram



**476<sup>00</sup>**

#6623 (SUN)  
Reg. user \$810.70



## 1200 LB. CAPACITY TRANSMISSION JACK

- Low lift 5-3/4" height
- Versatile saddle design allows for total adjustments in every direction
- 360 degree rotation of handle

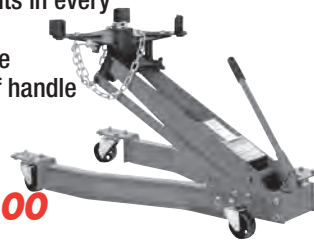

**429<sup>00</sup>**

#7750B (SUN)  
Reg. user \$724.51



## 1.5 TON CAPACITY TRANSMISSION JACK

- Used for removal, installation & moving of HD diesel truck transmissions
- Low height 8.62"; raised height 36.62"
- Wide chassis for load distribution
- Slow controlled lowering of load



**1,199<sup>00</sup>**

#7752C (SUN)  
Reg. user \$2,143.36



## TWO-STAGE TELESCOPIC TRANSMISSION JACK

- 1000 lbs. capacity
- Handles all passenger car, van, and light truck automotive transmissions, FWD transaxles and any air-cooled VW engines
- Greater lift range
- Low height 35.5" to high height 79.5"
- NEW-Slow release valve



**529<sup>00</sup>**

#7793B (SUN)  
Reg. user \$969.33

## 1000 LBS. CAPACITY AIR & HYDRAULIC TELESCOPIC TRANSMISSION JACK

- Low height 35.5"; raised height 75"
- Foot pedal operation
- Lowered telescopic rams
- Air activated first stage ram and hydraulic hand pump second stage ram



**979<sup>00</sup>**

#7796 (SUN)  
Reg. user \$1,663.36



## FUEL TANK ADAPTER

Use with Sunex #7793B & #7796

- Holds fuel tanks up to a 40 gallon capacity
- Unique saddle adapter fits most transmission jacks



**212<sup>00</sup>**

#7704 (SUN)  
Reg. user \$337.25

## 18V CORDLESS GREASE GUN



- Two speed switch for high pressure or high volume delivery
- Cycle indicator pin to monitor grease output
- "Smart" charging system delivers reliable power
- Includes 2 batteries, charger and case

1 BATTERY UNIT

**295<sup>00</sup>** **256<sup>00</sup>**  
#1844 (LIN) 1842 (LIN)

18V FIELD CHARGER

**45<sup>00</sup>**

#1815A (LIN)

POWERLUBER CHARGER

**46<sup>00</sup>**

#1410 (LIN)

18V SPARE BATTERY

**79<sup>00</sup>**

#1801 (LIN)

## 12V CORDLESS GREASE GUN

- Powerful 12v motor
- 3-way loading
- Includes 2 batteries, charger and case

**209<sup>00</sup>**

#1244 (LIN)



POWERLUBER FIELD CHARGER

**38<sup>50</sup>**

#1215 (LIN)

SPARE BATTERY

**74<sup>00</sup>**

#1201 (LIN)

## LEVER GREASE GUN

- Jam-proof toggle prevents binding or accidental bending of plunger
- Cast iron pump head for strength and durability
- Handy three-way loading by suction, filler pump or cartridge



**24<sup>50</sup>**

#1142 (LIN)

Reg. user \$30.35



## DELUXE LEVER GREASE GUN

- Same as #1142, with grip handle & vent valve

**32<sup>50</sup>**

#1148 (LIN)

Reg. user \$36.95



## LEVER GREASE GUN

- Same features as #1142
- 18" whip hose & coupler
- Flip-over follower set for cartridge use



**31<sup>50</sup>**

#1147 (LIN)

Reg. user \$38.65



## PISTOL GRIP GREASE GUN

- Fast, one-handed operation
- 18" whip hose and coupler
- Features & benefits of Lincoln lever type grease guns



**42<sup>00</sup>**

#1134 (LIN)

Reg. user \$50.20



## GUARDIAN GREASE GUNS

### STANDARD, LEVER-ACTION GREASE GUN

**13<sup>95</sup>**

#G100 (LIN)

### "THE BULLDOG", PREMIUM LEVER-ACTION GREASE GUN

**22<sup>95</sup>**

#G102 (LIN)

### MINI PISTOL GRIP GREASE GUN

**14<sup>50</sup>**

#G110 (LIN)

### HEAVY DUTY PISTOL GRIP GREASE GUN w/4" RIGID PIPE EXTENSION

**20<sup>69</sup>**

#G112 (LIN)

### HEAVY DUTY PISTOL GRIP GREASE GUN w/18" FLEX HOSE

**21<sup>95</sup>**

#G113 (LIN)

### SUCTION GUN

**12<sup>75</sup>**

#G150 (LIN)



## FULLY AUTOMATIC PNEUMATIC GREASE GUN

- Fully automatic, continuous operation
- Variable speed trigger
- Accessible check valve assembly
- 30" high pressure hose w/coupler and attachment clip
- Pump ratio: 40:1 at 150 PSI



**85<sup>00</sup>**

#1162 (LIN)





**New**



## 18V LITHIUM ION POWER LUBER

**The Most Advanced Grease Gun on the Market!**

The revolutionary 18-Volt PowerLuber features an LCD display that indicates grease dispensed cartridge level, charge level and more.

**SINGLE BATTERY**  
**366<sup>00</sup>**  
#1862 (LIN)

**DUAL BATTERY**  
**450<sup>00</sup>**  
#1864 (LIN)

**18-VOLT LITHIUM ION BATTERY**  
**132<sup>00</sup>**  
#1861 (LIN)

**HIGH OUTPUT ONE-HOUR CHARGER**  
**64<sup>00</sup>**  
#1850 (LIN)



## IMPACT FITTING CLEANER

- Clears hardened grease from fittings and joints
- Eliminates the need to disassemble joints or replace fittings
- Includes steel drive cylinder, hardened piston, safety shield, high pressure hose, spare drive seals, #5852 coupler



**34<sup>55</sup>**  
#5805 (LIN)



## 55 GALLON OIL PUMP

- 3 to 1
- 6 gallons per minute
- Works on motor oil, ATF and gear lube



**945<sup>00</sup>**  
#2424 (LIN)



## HD PORTABLE GREASE PUMP

- 50 to 1
- Air operated, double acting
- 7' heavy duty hose
- Includes follower plate



**769<sup>00</sup>**  
#6917 (LIN)



## GREASE PUMP

- 40 to 1
- Clamps to 25-50 lb. pail
- 7' connecting hose
- Includes follower plate



**545<sup>00</sup>**  
#4489 (LIN)



## HD GREASE PUMP

- 50 to 1
- Clamps to any 25-50 refinery container
- Carrying handle
- Rust-proofed cover



**879<sup>00</sup>**  
#989 (LIN)



## HD CHASSIS GREASE PUMP

- 50 to 1
- Will dispense 45 ounces or 80 cubic inches of NLGI 0-2 grease per minute at 150 psig
- Assures positive prime at lowest temperature



**969<sup>00</sup>**  
#917 (LIN)



## LEVER ACTION BUCKET PUMP

- Fits 25-50 lb. buckets
- Includes pump, drum cover & 4' delivery hose
- 18" drum cover



**36<sup>50</sup>**  
#G400 (LIN)



## HD GREASE CONTROL VALVE

- 7500 PSI maximum operating pressure
- All steel handle, body and guard bracket provides durability & longevity



**115<sup>00</sup>**  
#740 (LIN)



## 12V STANDARD DUTY DC PUMP

- 2" NPT, no tank adapter needed
- Delivers up to 13 GPM/49 LPM
- Includes hose & nozzle



**UL Listed!**

**309<sup>00</sup>**

#SD1202 (FIL)

**FILL-RITE**

## 12V BARREL PUMP

- 12 volt with 15 ft. battery cables
- Telescoping suction pipe
- 15 GPM
- Includes hose & nozzle



**UL Listed!**

**359<sup>00</sup>**

#FR1210C (FIL)

**FILL-RITE**

## 12V HIGH FLOW PUMP

- High flow rate of 20 GPM (76 LPM)
- Low 22 amp draw
- 1/4 HP, 12 volt DC motor
- Includes hose & nozzle



**UL Listed!**

**449<sup>00</sup>**

#FR4210D (FIL)

**FILL-RITE**

## 110V TRANSFER PUMP

- Up to 20 gallons per minute

**UL Listed!**



**539<sup>00</sup>**

#FR700 (FIL) **FILL-RITE**

## BARREL PUMP

- Vacuum breaker
- Bung adapter
- 3/4" outlet
- 100 strokes per 20 gallon
- 8 ft. hose and nozzle included



**169<sup>00</sup>**

#FR152 (FIL) **FILL-RITE**

## HD LEVER ACTION BARREL PUMP

- Fits 30-55 gallon drums
- Pump delivers 10 oz. per stroke
- Corrosive-resistant finish prevents rusting
- Curved metal spout features threads to fit all garden hoses



**31<sup>95</sup>**

#G401 (LIN)

**LINCOLN GUARDIAN**

## ROTARY BARREL PUMP

- Cast iron pump head for transferring petroleum-based, non-corrosive fluids
- Delivers approximately 1 gal. per 18 revolutions of handle
- Great for commercial, automotive & industrial use



**63<sup>95</sup>**

#G402 (LIN)

**LINCOLN GUARDIAN**

## OIL & GREASE HOSE REELS

See Page 35 for Air & Water Hose Reels

Made in USA!

1/4"x50' Grease Hose

**569<sup>00</sup>**

#94552 (LIN)

1/2"x50' Oil Hose

**569<sup>00</sup>**

#94354 (LIN)



**LINCOLN**

## 18 GAL. USED FLUID RECEIVER

- 18 gallon tank
- Large 14"/2.5 gal. bowl
- Uses standard shop air
- Excellent mobility, easy bowl positioning, simple pressurized evacuation



**LINCOLN**

**215<sup>00</sup>**

#3601 (LIN)

**New**

## PRESSURIZED WASTE OIL DRAIN

- Large 20 gallon capacity
- Large 18" bowl
- Telescopic bowl ranges from 44 - 72"



**LINCOLN**

**525<sup>00</sup>**

#3614 (LIN)



## DEF HAND LEVER PUMP

- 11 oz. per stroke
- Bung adaptor included
- Telescoping suction pipe included
- Poly propylene construction



**FILL-RITE**

**75<sup>00</sup>**

#FRHP32V (FIL)

### DISCHARGE HOSE KIT

**36<sup>50</sup>**

#KITHA32V (FIL)

**New**

## 5 GAL. OIL LIFT DRAIN

- Telescopic tube adjusts to desired height from 40.5" to 60" with 13.5" diameter funnel
- Comes complete with HD 5 gallon container, telescopic tube & sturdy funnel



**Performance Tool**

**67<sup>00</sup>**

#W54282 (WIL)

## PROFESSIONAL ROTARY DRUM PUMP

- Fluid types-oil, diesel, kerosene, coolant and ATF
- Approximately 1 gallon per 12 strokes
- Fits 16-55 gal. drums with 2" bung



**188<sup>00</sup>**

#1385H (LIN)

**LINCOLN**

## HD RIVETER

- Sets 1/4" rivets
- Self adjusting two-piece jaws
- Extra long handles
- Includes four screw-in nosepieces



**55<sup>00</sup>**

#26500 (AES)

**AES**

## DELUXE MASKER

- Sharp anodized blades for clean cutting
- Comfort grip handles
- Four tape reels for double side taping



**99<sup>00</sup>**

#200 (AES)

**AES**

## 4 & 10 TON PORT-A-JACK KITS



**4 TON**  
**209<sup>00</sup>**

#4940A (SUN)

Reg. user \$356.81

**SUNEX TOOLS**



**10 TON**  
**329<sup>00</sup>**

#4910A (SUN)

Reg. user \$520.55

## SLIDE HAMMER PULLER SET

- Eases removal of flange-type axles, oil seals, bearings
- Jaws can be set for 2 or 3 internal or external pulling
- Heavy duty steel carrying case

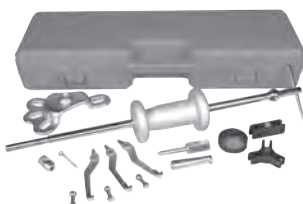

**80<sup>00</sup>**

#3911 (SUN)

Reg. user \$137.24

**SUNEX TOOLS**

## 7 PC AUTO BODY REPAIR KIT

- For pounding auto sheet metal before finishing
- Use on flat & curved surfaces
- Includes 3 hammers & 4 dollies



**26<sup>00</sup>**

#W1007DB (WIL)

**Performance Tool**

## 2 PC HLVP SPRAY GUN KIT

- Includes 1.5 mm spray gun and 1.2 mm touch up gun
- Fully adjustable spray pattern
- Fine adjustment knob for air flow



**62<sup>00</sup>**

#M503 (WIL)

**Performance Tool**

## GRAVITY FEED SPRAY GUN

- Superior performance- #2000 gold air cap produces an extremely fine finish with all materials
- Produces a high gloss finish and minimizes orange peel
- 32 oz. aluminum cup



**447<sup>00</sup>**

#GTI-620-G (DEV)  
Reg. user \$499.00

**DEVILBISS**  
The Right Way To Finish

## HVLP GRAVITY FEED SPRAY GUN

- For base coat, clear coat waterborne & high solids
- Includes .75 liter aluminum cup



**445<sup>00</sup>**

#M1-G (BIN)

**BINKS**

## PROFESSIONAL SPRAY GUN w/DRIPLESS CUP

- Designed for HD automotive spraying of all refinishing materials including urethanes, enamels, lacquers, primers, stains, acrylics and varnishes



**59<sup>00</sup>**

#102 (AES)

**AES**

## TOUCH-UP GUN & CUP

- Lightweight, compact design
- Overhead trigger for fine control
- Attachable siphon cup



**34<sup>50</sup>**

#SX10A (SUN)  
Reg. user \$52.79

**SUNEX**  
TOOLS

## DUAL SET-UP HVLP SPRAY GUN SET

- Set includes two production spray guns containing a 1.3 mm & 1.5 mm needle and nozzle set
- Locking regulator w/gauge
- 1000 ml aluminum paint cups
- Spray pattern control knob on side of guns



**77<sup>50</sup>**

#M706 (WIL)

**Performance Tool**

## TRIPLE SET-UP HVLP SPRAY GUN SET

- Set includes three production spray guns containing a 1.3 mm, 1.5 mm & 1.7 mm needle and nozzle set
- Locking regulator w gauge
- 1000 ml aluminum paint cups
- Spray pattern control knob on side of guns



**122<sup>00</sup>**

#M707 (WIL)

**Performance Tool**

## HVLP SPRAY GUN

- Economical, all purpose gun
- Sprays primers, base coats, sealers & clear coats
- 20 oz., drip free paint cup reservoir with filter screen
- Lightweight, comfortable grip



**45<sup>00</sup>**

#M4710 (WIL)

**Performance Tool**

## FULL SIZE GRAVITY FEED SPRAY GUN & CUP

- Gravity feed action uses less air and offers increased control over atomization and fluid output
- Fluid orifice-1.4 mm



**51<sup>00</sup>**

#9004A (SUN)  
Reg. user \$79.23

**SUNEX**  
TOOLS

## SPRAY GUN & CUP

- Chrome plated head and air nozzle
- External breather tube cup
- Dual action trigger



**42<sup>00</sup>**

#SX70C (SUN)  
Reg. user \$64.35

**SUNEX**  
TOOLS



## COMBINATION BENCH LATHE



**7,460<sup>00</sup>**   
#4000B (AMM)

**WITH FREE**  
#2500 Bench & #6E Kit

- Twin cutter tools and quick drum-to-rotor changeover
- Adjustable spindle speeds (if desired) allow for quick rough cut / finish cut settings
- Infinitely adjustable spindle-feed gear box
- User friendly ergonomics
- Supports drums or rotors up to 100 lbs using the standard one inch (25.4 mm) arbor, or up to 200 lbs. using the optional 1.875 inch (47.63 mm) arbor



**Ammco "B" Series Lathes Require The Purchase of One Of The Following Adapter Kits:**

**ADAPTER KIT 1A**

**850<sup>00</sup>**   
#900001 (AMM)

**ADAPTER KIT 2B**

**1,049<sup>00</sup>**   
#900002 (AMM)

**ADAPTER KIT 7F**

**2,199<sup>00</sup>**   
#900007 (AMM)

**ADAPTER KIT 3C**

**1,779<sup>00</sup>**   
#900003 (AMM)

**ADAPTER KIT 6E**

**1,635<sup>00</sup>**   
#900006 (AMM)



## HIGH VOLUME WHEEL BALANCER

- 1.5 HP direct-drive motor and 16 bit microprocessor
- 8 separate balancing modes
- Tire dia. up to 40"
- Rim width 2"-19.9"



**3,159<sup>00</sup>**   
#1000 (COA) **coats®**

## COMPUTER WHEEL BALANCER

- Low to medium volume
- Auto A&D data entry
- Direct tape-a-weight placement
- Balance wheels up to 130 lbs.
- 40mm arbor or shaft



**3,669<sup>00</sup>**   
#875 (COA) **coats®**

## ELECTRIC TIRE CHANGER, VALUE SERIES

- For alloy & steel wheels
- Air powered side bead loosener
- Rim diameter: 12"-19" external; 15"-22" internal
- Max tire width: 10"
- Max tire diameter: 40"
- Electric drive: 110v
- Required air source: 110-175 PSI
- 6 month parts warranty



**3,000<sup>00</sup>**   
#5035E (COA) **coats®**

## ELECTRIC TIRE CHANGER, VALUE SERIES w/CABINET

- For alloy & steel wheels
- Air powered side bead loosener
- Rim diameter: 10"-21" external; 12"-24" internal
- Max tire width: 10.5"
- Max tire diameter: 50"
- Electric drive: 110v
- Required air source: 110-175 PSI
- Full Rim Clamp® warranty



**3,315<sup>00</sup>**   
#5045E (COA) **coats®**

## HEAVY DUTY STRAIGHT LINE SANDER

- 3000 reciprocating strokes per minute
- Quick action paper clamps
- Smooth, reliable



**136<sup>00</sup>**

#315 (ING)  
Reg. user \$181.00



## 6" QUIET DUAL ACTION SANDER

- Ball bearing construction for vibration-free performance
- Built-in regulator for positive speed control
- Motor insulated housing allows quiet operation



**69<sup>00</sup>**

#SX203N (SUN)  
Reg. user \$107.73



## HEAVY DUTY DUAL-ACTION QUIET SANDER

- Vibration-free
- Dependable performance
- Positive speed control



**73<sup>00</sup>**

#311A (ING)  
Reg. user \$96.00



## HEAVY DUTY 8" GEARED ORBITAL SANDER

- Dual-action pad motion
- Vibration-free
- Balanced ball bearing construction



**154<sup>00</sup>**

#328B (ING)  
Reg. user \$205.00



**New**

## 6" RANDON ORBITAL PALM SANDER

- Tackles the toughest sanding
- Better balance and control
- Easy recognition of different sanders for specific needs
- Industry's lowest rating for vibration



**151<sup>00</sup>**

#SX7650 (SUN)



## ULTRA DUTY RANDON ORBITAL SANDER

- 12,000 rpm free speed for swirl-free finishes
- Lightweight
- Interchangeable grip rings available to match hand sizes



**175<sup>00</sup>**

#4151 (ING)  
Reg. user \$231.00



**New**

## 7" HORIZONTAL SANDER

- Tackles the toughest sanding
- Make changing the backing pad quick and easy
- Lowest vibration in it's class for hours of comfortable operation



**210<sup>00</sup>**

#SX7870 (SUN)



## 10" RANDOM ORBITAL POLISHER/BUFFER

- 0.92 amp 3000 rpm motor
- Light-weight 6 lb. design
- Large comfortable double handles
- Includes one terry cloth and one polishing bonnet



**32<sup>25</sup>**

#W50054 (WIL)



**New**

## 7" HORIZONTAL POLISHER

- Tackles the toughest sanding
- Makes changing the backing pad quick and easy
- Lowest vibration in it's class for hours of comfortable operation



**223<sup>00</sup>**

#SX7770 (SUN)



**New**

## 7"/9" VARIABLE SPEED POLISHER

- 12.0 amp ball bearing motor
- Heat-treated precision cut gears
- Variable speed trigger to control speed from 0 to dialed maximum setting



Powerful 12 AMP Motor

**229<sup>00</sup>**

#DWP849 (DEW)



## 4" HEAVY DUTY ANGLE GRINDER

- High torque motor for heavy duty performance
- Safety lever throttle
- Compact design for ease of handling
- Grinding wheel standard



**199<sup>00</sup>**

#SX211A (SUN)  
Reg. user \$315.49



## 4.5" ANGLE GRINDER

- 1.3 HP motor makes it strongest in its class
- 11,000 RPM
- Adjustable exhaust
- Spindle lock button
- Adjustable side handle



**209<sup>00</sup>**

#SX5245 (SUN)





## 4 1/2" HEAVY DUTY ANGLE GRINDERS



w/7 amp motor:

**84<sup>00</sup>**

#D28110 (DEW)

w/10 amp motor:

**124<sup>00</sup>**

#D28112 (DEW)



## 4 1/2" SMALL ANGLE GRINDER

- 10 AMP AC/DC 11,000 RPM Motor
- Dust Ejection System™
- Quick Change™ wheel release allows tool free wheel removal
- Paddle switch with safety lock off prevents accidental start up



**124<sup>00</sup>**

#D28402 (DEW)



## 7"/9" HEAVY DUTY LG. ANGLE GRINDER

- 15 amp, 8000 rpm motor
- 120V, AC/DC capacity



7" wheel  
**209<sup>00</sup>**

#D28474W (DEW)

Reg. user \$286.90

9" wheel

**255<sup>00</sup>**

#D28494N (DEW)

Reg. user \$345.53



## 1/4" AIR DIE GRINDER



**58<sup>00</sup>**

SX230B (SUN)

Reg. user \$84.06

## 1/4" MINI DIE GRINDER

**33<sup>00</sup>**

SX231B (SUN)

Reg. user \$42.74



**New**

## AIR STRAIGHT DIE GRINDER



- Powerful motor delivers 0.33 HP (0.25 kW) and 25,000 rpm free speed
- Lightweight, durable
- Complete with 1/4" and 6 mm collets and two wrenches

**97<sup>00</sup>**

#308B (ING)



Reg. user \$132.00

## 1/4" ANGLE DIE GRINDER

- 90° angle head for restricted areas
- Rear exhaust directs air away from work



**71<sup>00</sup>**

#SX232B (SUN)

Reg. user \$107.73



## MINI ANGLE DIE GRINDER

- Compact, lightweight
- 90 degree angle head
- Complete with 1/4" and 6mm collet



**69<sup>00</sup>**

#CP875 (CPT)



**New**

## MULTI-PURPOSE ANGLE DIE GRINDER

**71<sup>50</sup>**

#301B (ING)

Reg. user \$95.00



**New**

## HD ANGLE DIE GRINDER

**117<sup>00</sup>**

#302B (ING)

Reg. user \$156.00



## SHORT AIR HAMMER

- 3 pc. chisel set included



**41<sup>00</sup>**

#SX235KTB (SUN)



## GENERAL DUTY AIR HAMMER

- An excellent general purpose hammer
- Accepts .401" Parker taper chisels



**41<sup>00</sup>**

#SX275B (SUN)



## STANDARD DUTY AIR HAMMER

- Up to 3500 blows per minute
- Handles a range of cutting applications
- Long-life alloyed steel barrel & heat-treated piston



**59<sup>00</sup>**

#116 (ING)

Reg. user \$78.00



## SUPER DUTY AIR HAMMER

- Professional touch trigger for total control
- Long-life tool with a tough one piece alloy barrel



**122<sup>00</sup>**

#121 (ING)

Reg. user \$162.00



**New**

## LONG BARREL AIR HAMMER KIT

- Anti-vibration feature; 30% less
- 15% increase force over standard air hammers
- Quick-change retainer allows for faster chisel changeovers

**158<sup>00</sup>**

#118MAXK (ING)



**New**

## SHORT BARREL AIR HAMMER KIT

- Both Kits Include:
- Air hammer
  - Quick change retainer
  - 5 piece chisel set
  - Carrying case

**158<sup>00</sup>**

#122MAXK (ING)



## HD XRP™ 1/2" 18V CORDLESS DRILL/DRIVER KIT

- Delivers 450 unit watts of maximum power
- XRP™ extended run-time batteries
- 3-speed, all metal transmission
- Metal, ratcheting clutch

**349<sup>00</sup>**

#DCD940KX (DEW)

Reg. user \$516.74



## 3/8" HEAVY DUTY DRILL

- 6.0 Amp, 0-2500 rpm
- Variable Speed, Reversing
- 100% Ball Bearings
- Built-in 2 Way Level
- Includes Chuck Key & Holder

**Electric**

**89<sup>00</sup>**

#D21002 (DEW)

Reg. user \$110.51



## HEAVY DUTY VSR 1/2" DRILL

**Electric**



**139<sup>00</sup>** 850 rpm

#DW235G (DEW)

Reg. user \$185.76



**159<sup>00</sup>** 1200 rpm

#DWD210G (DEW)



## 12V, 3/8" CORDLESS COMPACT DRILL/DRIVER KIT

- Compact size for tight spaces
- Lightweight, 3.8 lbs.
- 3/8" ratcheting chuck
- Dual speed range 0-400/0-1450 rpm
- High performance frameless motor
- LED worklight



**187<sup>00</sup>**

#DC742KA (DEW)

## 3/8" REVERSIBLE AIR DRILL w/CHUCK

- Planetary gearing for heavy duty use
- Reversible
- One finger forward/reverse lever
- Jacobs chuck



**60<sup>00</sup>**

#SX223 (SUN)

Reg. user \$89.24



## 1/2" REVERSIBLE AIR DRILL w/CHUCK

- Heavy duty side handle for added control
- Jacobs chuck



**143<sup>00</sup>**

#SX221B (SUN)

Reg. user \$223.38



## 1/2" HEAVY DUTY REVERSIBLE DRILL

- Variable speed throttle
- Auxiliary side handle
- Quick reverse lever



**254<sup>00</sup>**

#7803RA (ING)

Reg. user \$341.00



## STANDARD DUTY 3/8" ANGLE REVERSIBLE DRILL

- Durable Jacobs multi-craft chuck
- Reversible, convenient control
- Comfortable lever throttle



**120<sup>00</sup>**

#7807R (ING)

Reg. user \$159.00



## HEAVY DUTY AIR CUT OFF TOOL

- Fast, quiet, 2-78" diameter
- Contoured lever throttle
- 360° rotatable chrome-plated spark guard



**73<sup>00</sup>**

#326 (ING)

Reg. user \$97.00





## UTILITY CUT-OFF TOOL

- Metal guard for added safety
- Built-in regulator
- Safety lever throttle



**52<sup>00</sup>**

#SX233A (SUN)  
Reg. user \$78.95



## HD AIR RECIPROCATING SAW

- Includes 6 high speed steel cutting blades & two hex wrenches
- Cut on flat or curved surfaces



**117<sup>00</sup>**

#429 (ING)  
Reg. user \$155.00



## HD XRP™ 18V CORDLESS RECIPROCATING SAW

- 1-1/8" stroke length
- 0-3000 spm
- 4-position blade clamp
- XRP™ extended run battery
- Variable speed



**297<sup>00</sup>**

#DC385K (DEW)  
Reg. user \$375.23



## 1/4" MINI AIR RATCHET WRENCH

- Ball & needle bearing construction for long life
- Lever throttle for positive speed control



**76<sup>00</sup>**

#SX106B (SUN)  
Reg. user \$110.03



## 105 SERIES AIR RATCHET

- 25 ft. lb. max torque and 250 rpm free speed
- Unique head construction provides improved durability and more consistent performance



**120<sup>00</sup>**

#105-D2 (ING)  
Reg. user \$165.00



## 1/4" DRIVE AIR RATCHET

- Max torque 30 ft. lbs.
- Working torque 5-30 ft. lbs.
- QuietTech™ exhaust system delivers 84 dBA
- Dura-life™ head design brings
- Durability and slip resistance



**129<sup>00</sup>**

#SX3825 (SUN)



## 3/8" DRIVE PALM IMPACT WRENCH

- Ring retainer for positive socket retention
- Butterfly throttle for directional control



**69<sup>00</sup>**

#SX111 (SUN)  
Reg. user \$99.56



## 3/8" AIR RATCHET WRENCH

- Ball detent socket retainer
- 45 ft. lbs. torque
- 150 rpm for quick rundown
- Ball & needle bearing construction



**52<sup>00</sup>**

#SX113 (SUN)  
Reg. user \$79.53



## 3/8" HEAVY DUTY RATCHET

- Up to 50 ft. lbs. torque
- Variable speed throttle
- Ball & needle bearing



**118<sup>00</sup>**

#107XPA (ING)  
Reg. user \$159.00



## 3/8" SUPER DUTY RATCHET

- 360° adjustable exhaust
- Push button throttle
- Durable, high power design



**187<sup>00</sup>**

#109XPA (ING)  
Reg. user \$248.00



## 1/2" HEAVY DUTY RATCHET

- 360° adjustable exhaust
- Variable speed throttle
- Up to 50 ft. lbs. torque



**144<sup>00</sup>**

#1077XPA (ING)  
Reg. user \$191.00



## 3/8" PISTOL GRIP IMPACT WRENCH

- Ring socket retainer for rapid socket changes
- Front bumper for added protection



**77<sup>00</sup>**

#SX821A (SUN)  
Reg. user \$120.21



## SUPER DUTY AIR IMPACT WRENCH

- Power up to 180 ft. lbs.
- Unaffected by air pressure changes
- More torque and less vibration
- Pistol-style, yet compact



**199<sup>00</sup>**

#212 (ING)  
Reg. user \$267.00



## HAMMERHEAD LOW-PROFILE IMPACTOOL™

- MAX Power - 180 ft. lbs., 7000 rpm
- MAX Control - feather touch trigger, two position forward power regulator & conveniently located forward/reverse ring
- MAX Access - under 2" head height and reactionless torque allows for safe use in tight spaces



3/8" **319<sup>00</sup>**

#2015MAX (ING)

## 3/8" IMPACT WRENCH

- 300 ft. lbs. of quiet power
- One hand forward/reverse
- Quiet Tech™ exhaust system delivers 79 dBA
- Weighs only 2.75 lbs.



**199<sup>00</sup>**

#SX4335 (SUN)  
Reg. user \$331.49



## 1/2" HD AIR IMPACT WRENCH

- High-powered pin clutch delivers over 450 ft. lbs. of max. torque
- Working torque range 25-350 ft. lbs.
- Rear knob regulator and variable speed trigger
- Cushion grip design



**96<sup>00</sup>**

#SX959A (SUN)



## 1/2" 18V CORDLESS XRP™ IMPACT WRENCH KIT

- 300 ft. lbs. of max torque
- Comfort grip provides max comfort
- Preferred rocker switch design for fast & easy forward & reverse



**435<sup>00</sup>**

#DW059K2 (DEW) 

## HEAVY DUTY 1/2" IMPACT WRENCH

- 325 ft. lbs. torque
- Hog-ring style
- AC/DC forward/reverse switch
- 7.5 amp, 2100 rpm, 2700 bpm
- Ball-bearing construction



Electric

**225<sup>00</sup>**

#DW293 (DEW)   
Reg. user \$323.84

## 1/2" HEAVY DUTY IMPACT WRENCH

- 375 ft. lbs. of max torque
- Handle exhaust
- Full power in reverse; adjustable power in forward



**129<sup>00</sup>**

#236 (ING)  
Reg. user \$178.00



## 1/2" IMPACT WRENCH

- 750 ft. lbs. of quiet power
- 1100ft. lbs. of breakaway torque
- One hand forward/reverse
- Quiet Tech™ exhaust system delivers 82 dBA
- Weighs only 4.3 lbs.



**179<sup>00</sup>**

#SX4345 (SUN)  
Reg. user \$340.13



## 1/2" IMPACT WRENCH w/2" EXT. ANVIL

- Gives the same performance & benefits of the SX4345, but with a 2" extended anvil



**208<sup>00</sup>**

#SX4345-2 (SUN)  
Reg. user \$352.65



## 1/2" SUPER DUTY IMPACT WRENCH

- Durable twin hammer impact mechanism
- Pressure-feed lubrication
- Variable speed



**159<sup>00</sup>**

#231C (ING)  
Reg. user \$244.00



## IQv SERIES 1/2" CORDLESS IMPACT WRENCH



- 360 ft. lbs. max torque

**229<sup>00</sup>**

#W360 (ING)

Required Accessories:

Lithium ION Battery

Battery Charger

**166<sup>00</sup> 105<sup>00</sup>**

#BL192 (ING) #BC20 (ING)



## 1/2" SUPER DUTY IMPACT WRENCH

- 450 ft. lbs. max torque
- Pressure-feed lubrication
- Variable power control in forward & reverse
- Quieter operation



**159<sup>00</sup>**

#231HA (ING)  
Reg. user \$244.00



## 1/2" SUPER DUTY EXTENDED ANVIL

- The standard of 1/2" tire tools gives you the same performance advantages of the classic 231, but with a 2" extended anvil



**195<sup>00</sup>**

#231HA-2 (ING)  
Reg. user \$281.00



## 1/2" SUPER DUTY IMPACT WRENCH

- Powerful, with smooth balanced blows
- Variable speed trigger
- Pressure feed lubrication system



**299<sup>00</sup>**

#244A (ING)  
Reg. user \$401.00



## 1/2" TITANIUM DUTY AIR IMPACTOOL™

- 780 ft. lbs.
- Light/compact... weighs only 3.95 lbs.
- Push button forward/reverse controls for one hand operation
- Enhanced controls



**329<sup>00</sup>**

#2135TiMAX (ING)  
Reg. user \$499.00



## 3/4" IMPACT WRENCH

- 1400 ft. lbs. of quiet power
- One hand forward/reverse
- Quiet Tech™ exhaust system delivers 90 dBA
- Weighs only 7.55lbs.



**469<sup>00</sup>**

#SX4355 (SUN)  
Reg. user \$801.89



## 3/4" IMPACTOOL™

- Delivers 1050 ft. lbs. of max torque
- Two power settings in forward & reverse
- Variable speed trigger
- Handle-vented exhaust



**395<sup>00</sup>**

#259 (ING)  
Reg. user \$578.00



## 3/4" SUPER DUTY AIR IMPACT WRENCH

- Smoothest operating 3/4" impact on the market
- One hand push button forward reverse power regulator
- Handle exhaust
- Comfortable contoured handle grip
- Ultimate Torque: 1000 ft. lbs.



**499<sup>00</sup>**

#CP772H (CPT)



## 3/4" SUPER DUTY IMPACT WRENCH

- Jumbo hammer mechanism
- Up to 1100 ft. lbs. of torque
- Handle exhaust



**539<sup>00</sup>**

#261 (ING)  
Reg. user \$782.00



## 3/4" DRIVE MAX SERIES IMPACTOOL™

- MAX 1350 ft. lb. torque
- 2 year limited warranty
- Weight 7.4 lbs.
- 16% more efficient motor than predecessor



**595<sup>00</sup>**

#2145QIMAX (ING)



## 1" IMPACT WRENCH w/6" ANVIL

- 1600 ft. lbs. of torque
- Weighs only 24.5 lbs.
- 3 forward & 3 reverse speeds
- Pinless clutch for lower vibration & long last operation



**329<sup>00</sup>**

#SX556 (SUN)



## 1" SUPER DUTY IMPACT WRENCH

- Impressive power to size ratio
- Up to 1100 ft. lbs. of torque
- Dead handle improves operator control



**625<sup>00</sup>**

#271 (ING)  
Reg. user \$904.00



## 1" HEAVY DUTY EXTENDED ANVIL

- 1450 ft. lbs. of max torque
- High efficiency 6-vane motor
- 3-position power regulator
- 6" extended anvil



**619<sup>00</sup>**

#285B-6 (ING)  
Reg. user \$899.00



## 5000 WATT GENERATOR

- Manual Start
- Powermate OHV engine-6.5 gallon
- 2 year warranty
- Voltage: 120V/240V AC 12 volts DC
- 6250 peak amps
- 180 lbs.



**659<sup>00</sup>**

#PM0105007 (COL)

## 9000 WATT MOBILE GENERATOR w/ELECTRIC START

- Powered by 15HP OHV forced air-cooled, 4 stroke engine
- Runs 8.5 hours @ 1/2 load
- Operating noise 76dB
- Outlets: (2) AC 120V, (1) 120V twist lock (1) 120/240V twist lock (1) 12V DC



**849<sup>00</sup>**

#GG900E (COL)

## ATF REFILL SYSTEM

- Provides complete system for servicing sealed automatic transmissions
- Allows operator to fill or top off transmissions with up to 1 gal. of fluid between refills
- Pressurized operation frees the operator from continual pumping



**269<sup>00</sup>**

#MV6410 (LIN)

**mityvac**  
VACUUM PUMP

## AUTOMOTIVE TEST & BLEED KIT

- Features newly updated Selectline hand vacuum pumps
- Performs numerous engine diagnostic & mechanical tests



**36<sup>50</sup>**

#MV8000 (LIN)  
Reg. user \$47.55

**mityvac**  
VACUUM PUMP

## SILVERLINE ELITE AUTOMOTIVE KIT

- Silverline Elite vacuum pump
- Brake bleeding accessories
- Master cylinder refill kit
- User's manual
- Custom molded case



**68<sup>00</sup>**

#MV8500 (LIN)  
Reg. user \$85.05

**mityvac**  
VACUUM PUMP

## UNIVERSAL STRETCH-FIT® INSTALLATION TOOL

- One tool for any job
- Available separately applications where a tool must be used
- More economical than disposable versions
- Includes a re-usable universal tool & mounting bolt



**10<sup>50</sup>**

#91030 (GAT)  
Reg. user \$25.99

**Gates**

## VACUUM BRAKE BLEEDER/ EVACUATOR

- Large capacity reservoir
- Bleeds up to 2 quarts/minute
- Variable thumb throttle holds desired flow rate
- Swivel air inlet
- Bench mountable
- Automatic shut-off valve



**154<sup>00</sup>**

#MV6830 (LIN)  
Reg. user \$203.20

**mityvac**  
VACUUM PUMP

## 14" CHOP SAW

- 15 amps
- 3800 rpm no load speed
- 4 Horsepower
- Quick lock vise
- 5" max capacity (round)



**229<sup>00</sup>**

#D28710 (DEW)  
Reg. user \$315.00

**DEWALT**  
High Performance Industrial Type

## COOLING SYSTEM PRESSURE TEST KIT

- Quickly reveals external cooling system leaks
- Detects internal leaks caused by blown head gasket, or cracked block or head
- Includes pressure pump w/2' hose
- (4) adapters
- Adapter wrench



**165<sup>00</sup>**

#MV4530 (LIN)

**mityvac**  
VACUUM PUMP

## AIR OPERATED FLUID EVACUATOR

- Evacuates and dispenses most automotive liquids and chemicals, including transmission fluid, coolant, brake fluid, gear and engine oil
- Large capacity 8.8 liter fluid reservoir
- No electrical or compressed air required



**110<sup>00</sup>**

#MV7300 (LIN)

**mityvac**  
VACUUM PUMP



## FUEL & TRANSMISSION LINE DISCONNECT TOOL SET

- Fuel line disconnect tools sizes 1/4", 5/16", 3/8" and 1/2"
- Oil cooler line disconnect tool
- Fuel line coupling tool
- Ford & Mercury oil cooler line disconnect tool
- Ford & GM quick disconnect tool



**46<sup>00</sup>**

#W89330 (WIL)



## 20 GALLON PARTS WASHER & STAND

- 20 gallon capacity
- Durable powder coat finish
- Removable shelf for versatility
- Flexible chrome plated nozzle
- Circulates 50 gallons per hour



**159<sup>00</sup>**

#W54040 (WIL)



## 42" PADDED LOW PROFILE STEEL CREEPER

- HD vinyl
- 2" ball bearing wheels



**86<sup>00</sup>**

#96302 (LIS)

Reg. user \$85.95



## PLASTIC LOW PROFILE JEEPERS CREEPERS®

- Body-fitting design
- Six, pop-in style 2" urethane wheels
- Low profile, 7/8" clearance
- Super rugged, one piece plastic body
- Resistant to solvents, grease & fuel
- Optional light holder & tool tray available



**75<sup>00</sup>**

#92102-BTB (LIS)



## 4 CASTER CREEPER

- Length-36"
- Powder coated black frame
- Cushioned red vinyl cover



**49<sup>95</sup>**

#8504 (SUN)



## 6 CASTER CREEPER

- Length-40"
- Powder coated black frame
- Cushioned red vinyl cover with adjustable head rest



**69<sup>95</sup>**

#8505 (SUN)



## LISLE NEW, IMPROVED PLASTIC CREEPERS



Low Profile Red Low Profile Blue

**84<sup>00</sup>**

#92102 (LIS)

**84<sup>00</sup>**

#94102 (LIS)

## CREEPER SEAT

- Powder coated black frame
- Includes convenient parts storage tray



**36<sup>95</sup>**

#8507 (SUN)



## EZ SET PROFESSIONAL SHOP SEAT

- Easy height adjustment
- (5) 2 1/2" casters
- Large 15 1/4" diameter tool tray



**56<sup>00</sup>**

#8509 (SUN)



## TRACTOR SEAT

- Air cylinder for easy height adjustment
- (5) 3 1/2" heavy duty, chrome finish casters with rubber tread
- Large, reinforced 17" diam. 1" deep tool tray



**107<sup>00</sup>**

#8514 (SUN)



## BENCH TOP DRILL PRESS

- 5 speed, 1/4 hp
- Drills metal, plastic & wood
- 1/2" spring-loaded chuck w/guard & 2 1/2" vise
- Adjustable table tilts 45° left & right



**119<sup>00</sup>**

#W50005 (WIL)



## 16 SPEED DRILL PRESS

- HD 3/4" hp motor
- Convenient belt tension lever
- Table rotates 360° and pivots
- Replaceable 5/8" chuck & key available



**449<sup>00</sup>**

#5000A (SUN)



## 2 SPEED ELECTRIC HOT AIR GUN

- Powerful heated airflow
- Dual temperature control
- 300°C & 500°C heat settings



**19<sup>50</sup>**

#W50076 (WIL)



## 1600 WATT HEAVY DUTY HEAT GUN

- Temp range between 1000 and 1100°F
- UL listed
- Detachable 3 position steel base
- Die cast housing



**75<sup>00</sup>**

#W50078 (WIL)



## PROFESSIONAL WORKSHOP VISE

**Ken-Tool**



**5 1/2" 164<sup>00</sup>**

#64055 (KEN)

**6 1/2" 206<sup>00</sup>**

#64065 (KEN)

**5" VISE 78<sup>00</sup>**

#MV-5 (WIL)



**6" VISE 112<sup>00</sup>**

#MV-6 (WIL)

**New**

## FUEL CADDY

- 25 gallon steel tank
- 2-way rotary pump dispenses or extracts fuel at one gallon per 12 revolutions
- 2-way filter system removes particulates during use
- Sight glass clearly indicates fuel volume in tank



**549<sup>00</sup>**

#3677 (LIN)



## SOLDERING GUN KIT

- UL listed
- Pistol grip style
- Instant heat, 85 watts
- Includes extra tip



**19<sup>50</sup>**

#W2019A (WIL)



## 6" BENCH GRINDER w/LIGHT

- Bright, flexible work light
- 1/2 hp, 3.5 amp motor
- Protective spark guard and eye shield



**136<sup>00</sup>**

#5001A (SUN)

8" Model with 3/4 hp, 5 amp motor

**154<sup>00</sup>**

#5002A (SUN)



## HALOGEN PROJECT WORK LIGHT

**500 Watt**

- Tempered glass lens
- Foam grip, "S" type
- Polarized plug
- Powder coat finish



**16<sup>95</sup>**

#524200 (PSL)



## CONVERTIBLE HALOGEN TRIPOD

**1000 Watt**

- Tempered glass lens
- Telescoping tripod w/adjustable leg



**59<sup>95</sup>**

#524206 (PSL)





## TORQUE WRENCHES

- 25-250 ft. lb.
- 3/8" drive

**55<sup>50</sup>**  
#M197 (WIL)

- 10-100 ft. lb.
- 3/8" drive

**55<sup>50</sup>**  
#M198 (WIL)

- 30-250 ft. lb.
- 1/2" drive

**79<sup>00</sup>**  
#M199 (WIL)



## 1/2" CLICK TORQUE WRENCH

**24<sup>00</sup>**

#M200DB (WIL)



## 1/4" DRIVE 250 IN./LB. TORQUE WRENCH

- Patented torque adjusting lock unlock collar
- High grade spring steel torque mechanism
- Heavy duty case



**49<sup>00</sup>**

M196 (WIL)



## 20 TON HYDRAULIC PRESS

- All welded steel construction
- Heavy duty return springs for fast ram retraction
- Hydraulic power unit included



**815<sup>00</sup>**

#5220 (SUN)

Reg. user \$1,394.51



## STAINLESS STEEL DIAL CALIPER

- Measures outside, inside, step and depth
- Features adjustable dial & thumb wheel fine adjustment
- 0-6" Range, .001" (.02mm) graduations; .100" (2.0mm) range/revolution



**30<sup>00</sup>**

W80151 (WIL)



## STAINLESS STEEL DIGITAL CALIPER

- Measures outside, inside, step and depth
- Large, easy to read LCD display
- 0-6" Range (0-150mm) with SAE to metric conversion
- Battery included



**20<sup>00</sup>**

W80152 (WIL)



## SERVICE CART w/LOCKING TOP & LOCKING DRAWER

- Load capacity of 350 lbs.
- Chrome 16 gauge steel frame
- 3" deep shelves
- Roller bearing slides



**198<sup>00</sup>**

#8013A (SUN)

Reg. user \$330.98

w/o Drawer

**117<sup>00</sup>**

#8005SC (SUN)



## SLIDE TOP UTILITY CART

- 450 lbs. rated capacity
- Oversized 5" wheels and casters
- Compact
- Locking slide top and drawers
- Grooved rubber mats on work surface



**299<sup>00</sup>**

#8035 (SUN)

Reg. user \$512.95



## PROFESSIONAL DUTY 5 DRAWER SERVICE CART

- 75% assembled making it quick and easy to put together
- Flip top locking lid, 5 drawers (three 1.5" deep, one 3" deep and one 5" deep) all preassembled and keyed the same, plus a screwdriver/prybar holder and side work shelf
- EVA foam drawer liners included
- Large 5" wheels: 2 locking and 2 standard
- Chrome 16 gauge steel frame
- Durable powder coated finish



**439<sup>00</sup>**

#8045 (SUN)



## PORTABLE EVAPORATIVE COOLING UNITS

### JETSTREAM 2400

- Air Delivery CFM: 7500
- Total Amps: 5.0 amp
- 48 gallon water capacity
- Dimensions:  
54.5"W x 28"D x 71.75"H
- Cooling capacity: 2000 sq. ft.

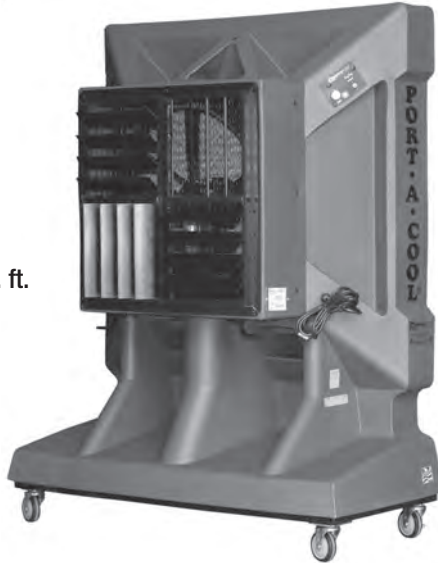

**1,949<sup>00</sup>**

#PACJS2400 (PTC)

### 16" HEAVY DUTY COOLER

- Air Delivery CFM:  
2500/3300/3900
- 42 gallon water capacity
- Total Amps: 5.1 amp
- Dimensions:  
59"H x 37.5"W x 23"D
- Cooling capacity 900 sq. ft.



**1,199<sup>00</sup>**

#PAC163SVT (PTC)

### CYCLONE 2000 COOLER

- Air Delivery CFM: 2000
- 8 gallon water capacity
- Dimensions:  
24"W x 25"D x 31"H
- Cooling capacity: 500 sq. ft.



**515<sup>00</sup>**

#PAC2KCYCO2 (PTC)

### CYCLONE 3000 COOLER

- Air Delivery CFM: 3000
- Total Amps: 5.6 amp
- 16 gallon water capacity
- Dimensions:  
29"W x 25"D x 38"H
- Cooling capacity: 700 sq. ft.



**699<sup>00</sup>**

#PAC2KCYCO1 (PTC)

### 36" THREE SPEED COOLER

- Air Delivery CFM: 4800/6600/9600
- 32 gallon water capacity
- Total Amps: 11.5 amp
- Dimensions: 67"H x 62"W x 32"D
- Cooling Capacity: 2500 sq. ft.



**2,350<sup>00</sup>**

#PAC2K363S (PTC)



### NON-CONTACT INFRARED THERMOMETER

- Measures surface temperature without making contact, Fahrenheit or Celsius
- Laser pointer for accuracy
- Easy to read digital display



**59<sup>00</sup>**

#W89720 (WIL)





## 600 LB. HAND TRUCK

- 600 lb. capacity
- Loop handle
- 10" pneumatic tires
- Weight 22 lbs.



**67<sup>00</sup>**

#34001 (AG)

Reg. user \$89.00

## 2 PC. SPRING COMPRESSOR

- Ideal for removal and installation of auto & light truck coil springs
- Strong steel jaws securely hook into coil springs
- Use on or off vehicle



**30<sup>50</sup>**

#3903 (SUN)



## VARIABLE SPEED PORTABLE AIR BLOWER

- Moves up to 300 cubic ft. per minute
- Built-in carry handle
- Dries wet surfaces fast

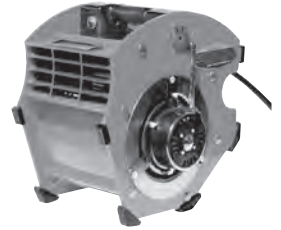

**78<sup>50</sup>**

#W50061 (WIL)



## RETRACTABLE AIR or WATER HOSE REELS

- HD 50' rubber air hose
- 1-year limited warranty

**3/8"**  
**137<sup>00</sup>**

#83753 (LIN)

**1/2"**  
**154<sup>00</sup>**

#83754 (LIN)



LINCOLN

See Page 20 for  
Oil & Grease Reels!

## AIR HOSE REEL

- Provides a large 10" diameter reel to prevent tight coils in the air hose
- Two built-in tool hangers keep air chuck, blow gun, or other air tools close at hand

(hose not included)



**62<sup>00</sup>**

#50350 (LIS)



## PORTABLE AIR TANK

- 125 PSI maximum
- Safety pressure by-pass valve
- On/off air adjustment dial
- Industrial grade hose & chuck

**5 Gallon**  
**40<sup>00</sup>**

W10005 (WIL)

**11 Gallon**  
**57<sup>00</sup>**

W10011 (WIL)



## PNEUMATIC SPARK PLUG CLEANER

- Internally controlled abrasive blasting
- Uses ordinary air line pressure
- External 2 position lever
- Blasting material included

**37<sup>50</sup>**

#18500 (AES)



**AES**

## ABRASIVE BLASTING MATERIAL

- 4 ounce

**4<sup>49</sup>**

#18501 (AES)  
Reg. user \$4.50

## PRESSURIZED SAND BLASTER

- 10 gallon
- Includes pressure gauge, air filter, nozzle and shut-off valve
- 4 ceramic nozzles
- 9 ft. hose, filling funnel, and canvas hood

**249<sup>00</sup>**

#1000 (AES)



**AES**

## SHOP FLAME II TORCH KIT

- Welds up to 1/2" and cuts up to 6"
- Features built-in reverse flow check valves
- Complete with 20' hose
- Medium duty oxygen-acetylene unit



**226<sup>00</sup>**

Forney INDUSTRIES, Inc.

#01705 (FWP)  
Reg. user \$429.00

## COMMANDER HD TORCH KIT

- Heavy duty oxygen-acetylene unit
- Welds up to 1/2" and cuts up to 8"
- 1/4"x25' twin hoses



**409<sup>00</sup>**

Forney INDUSTRIES, Inc.

#01711 (FWP)  
Reg. user \$529.00

**New**

## 120V PLASMA CUTTER W/AIR COMPRESSOR

- 120 volts / 12 amps
- Easily cuts 1/8"
- Severs up to 1/4"
- Duty cycle: 25% @ 12 amps



**859<sup>00</sup>**

#00317 (FWP)

Forney INDUSTRIES, Inc.

## 95 FI FLUX CORE WELDER

- 120V/90A
- Simple to operate
- Welds all types of carbon steel with 1/8" max metal thickness
- Welds with .030" or .035" wire
- Two power settings
- Electronic wire speed control with Tweco® type torch



**349<sup>00</sup>**

#00304 (FWP)

Forney INDUSTRIES, Inc.

## 130 FI FLUX CORE/MIG WIRE WELDER

- 120V/130A
- Welds mild steel, aluminum, stainless steel and cast iron (requires correct wire and gas)
- Welds up to 3/16" in a single pass with .023", .030" or .035" wire
- Multiple power settings
- Tweco® type torch with full ON OFF safety control



**459<sup>00</sup>**

#00306 (FWP)

Forney INDUSTRIES, Inc.

## 180 FI FLUX CORE/MIG WIRE WELDER

- 230V/180A
- Welds mild steel, aluminum, stainless steel and cast iron (requires correct wire and gas)
- Welds up to 1/4" (3/16" in a single pass) with .023", .030" or .035" wire
- Multiple voltage settings for accurate heat control
- Tweco® type torch with full ON/OFF safety control



**569<sup>00</sup>**

#00308 (FWP)

Forney INDUSTRIES, Inc.

**New**

## INSTA-SHADE WELDING HELMETS

- Auto-Darkening #9 - #13 variable shade
- 1/30,000 second switching speed
- Large 3.86" x 2.17" viewing area
- Four optical sensors
- Outside mounted shade selector knob & sensitivity adjustment
- Solar cells w/built-in replaceable 3V Lithium Batteries
- Meets ANSI Z87.1 Safety Standards



Glory  
**115<sup>00</sup>**

#55654 (FWP)

Anarchy  
**115<sup>00</sup>**

#55655 (FWP)

Forney INDUSTRIES, Inc.



## HALOGEN PROJECT WORK LIGHT

**500 Watt**

- Tempered glass lens
- Foam grip, "S" type
- Polarized plug
- Powder coat finish



**\$16<sup>95</sup>**

#524200 (PSL)



## HD RIVETER

- Sets 1/4" rivets
- Self adjusting two-piece jaws
- Extra long handles
- Includes four screw-in nosepieces



**\$55<sup>00</sup>**

#26500 (AES)

## 12V HIGH FLOW PUMP

- High flow rate of 20 GPM (76 LPM)
- Low 22 amp draw
- 1/4 HP, 12 volt DC motor
- Includes hose & nozzle



**\$449<sup>00</sup>**

#FR4210D (FIL) **FILL-RITE**

## **New!** SOLAR POWER INVERTER

- 3,000 Watts
- Stable, clean and reliable power with high surge capacity for use in powering a wide variety of electronics, appliances and power tools

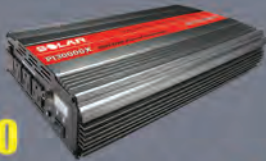

**\$595<sup>00</sup>**

#PI3000X (SLR)

**SOLAR**

## HVLP SPRAY GUN

- Economical, all purpose gun
- Sprays primers, base coats, sealers & clear coats
- 20 oz., drip free paint cup reservoir with filter screen
- Lightweight, comfortable grip



**\$45<sup>00</sup>**

#M4710 (WIL)



## 1" Impact Wrench w/6" Anvil

- 1600 ft. lbs. of torque
- Weighs only 24.5 lbs.
- 3 forward & 3 reverse speeds
- Pinless clutch for lower vibration & long last operation



**\$329<sup>00</sup>**

#SX556 (SUN)



## LEASING INFORMATION

*Affordable payments...potential decreased tax liabilities...preservation of bank credit lines...easy add-ons and/or upgrades...and improved cash flow. Benefits like these cause most businesses to use lease financing to acquire capital equipment required to compete and grow without impacting cash flow or bank credit lines.*

- Leasing allows you to use the equipment while generating the revenue to make the agreed-upon payment
- Lease payments may be fully deductible as a business expense
- You may be able to include other expenses associated with equipment use as installation, software, etc.
- Leasing doesn't tie-up your existing line of credit...keeps your cash and credit line available to take advantage of other business opportunities.
- Flexible payment options from 12-60 months with end of lease purchase or renewal options.

*It's really simple to do! Contact your local Bumper to Bumper Auto Parts store for lease applications.*

## STOCKING CODE



**= FACTORY SHIP**

Items designated with the  icon will be shipped direct from the factory.

©2012 Parts Warehouse, Inc. its subsidiaries and affiliates do not manufacture any of the products listed in the ToolTalk Catalog. PWI disclaims any warranty under the ToolTalk catalog implied warranty of merchantability and fitness for a particular purpose and any responsibility for the content of each manufacturer's warranty. PWI reserves the right to limit quantities and to correct pricing errors and the right to substitute products of equal or greater value. Prices good at participating Bumper to Bumper Auto Parts stores. Errors in prices, descriptions, and/or illustrations of them are not the responsibility of Parts Warehouse, Inc., its agencies or affiliates. Some items may require special order.



**New!**

## INSTA-SHADE WELDING HELMETS

- Auto-Darkening #9 - #13 variable shade
- 1/30,000 second switching speed
- Large 3.86" x 2.17" viewing area
- Four optical sensors
- Outside mounted shade selector knob & sensitivity adjustment
- Solar cells w/built-in replaceable 3V Lithium Batteries



**FORNEY INDUSTRIES, INC.**

Glory  
**\$115<sup>00</sup>**

#55654 (FWP)

Anarchy  
**\$115<sup>00</sup>**

#55655 (FWP)

PRST STD  
U.S. Postage  
**PAID**  
America  
Direct

# TOOLTALK

P.O. Box 15717  
Little Rock, AR  
72231-5717

**BUMPER TO BUMPER**  
Auto Parts Specialists

**New!**

## 2600 PSI PRESSURE WASHER

- 2.3 GPM
- 160cc Honda GC160 OHV engine
- Dolly style configuration for maneuverability
- 9" pneumatic tires
- 25' x 1/4" high pressure hose



**\$499<sup>00</sup>**

#PWFC132600.04 (COL)

## ECONOMY 5 DRAWER TOP CHEST

**\$259<sup>00</sup>**

EFT2605 (INT)

## ECONOMY 3 DRAWER ROLLER CABINET

**\$299<sup>00</sup>**

ETB2703 (INT)

- Great starter tool storage system
- Powder coat paint
- 3"x1" casters



	Width	Depth	Height
EFT2605	26"	12"	14 1/2"
ETB2703	27"	17 1/4"	30"

**New!**

## SUPER SOLAR SPECIALS

**New!**

### DIGITAL BATTERY & SYSTEM TESTER WITH INTEGRATED PRINTER

- Complete testing solution for 6 and 12 Volt batteries and 12 and 24 Volt charging systems
- 1.5-30V Operating range



**\$539<sup>00</sup>**

#BA327 (SLR)

### 6/12V WHEELED BATTERY CHARGER

- 40 Amp 12V fast charge rate
- 20 Amp 12V medium charge rate
- 5 Amp 12V low charge rate
- 40 Amp 6V charge rate
- 200 Amp 12V engine starting assistance



**\$179<sup>00</sup>**

#4725 (SLR)

### INTELLIGENT WHEELED CHARGER w/ENGINE START

- 6/12 Volt
- 60/40/15/5A charge rates
- 275A of Engine Starting Assistance
- Fully automatic operation



**\$418<sup>00</sup>**

#PL3730 (SLR)