

A Decision Support System for Earth Moving Planning at the Bidding Stage

by

Chen Sun

A thesis submitted in partial fulfillment of the requirements for the degree of

Master of Science

in

Construction Engineering and Management

Department of Civil and Environmental Engineering  
University of Alberta

© Chen Sun, 2015

## **Abstract**

Earth moving projects are commonly involved in the construction industry for tasks such as road construction, pipeline installation, surface mining, and so on. All the operations in earth moving projects are completed by a fleet of different construction equipment. Since earth moving projects take place in exposed fields, the circumstance associated make these projects full of uncertainties. Through interviews with engineers from construction companies, it was found that traditional planning methods lack sufficient assessment of risks in earth moving projects, which increases the probability of cost or duration overrun. Therefore, this thesis research aimed to develop a decision support system for earth moving planning at the bidding stage. Using artificial neural networks and simulation as the main research tools, the developed decision support system can analyze the impacts of potential risks in earth moving projects. It can help construction companies understand the effects of risks in earth moving projects to aid in decision making at the bidding stage and improvement of companies' risk management. A new earth moving template that is convenient for industrial practitioners to do estimation and risk analysis is also developed.

## Table of Contents

Chapter 1: Introduction.....	1
1.1 Background.....	1
1.2 Problem Statement.....	2
1.3 Research Objective.....	4
1.4 Thesis Organization.....	5
Chapter 2: Literature Review.....	7
2.1 Introduction.....	7
2.2 Earth Moving Operations Planning Methodologies.....	8
2.2.1 Industrial Practice.....	8
2.2.2 Previous Research in Supporting Earth Moving Planning.....	9
2.3 Risk Analysis in Construction Engineering.....	15
2.4 Monte Carlo Simulation.....	16
2.5 Summary.....	17
Chapter 3: Research Methodology.....	18
3.1 Introduction.....	18
3.2 Components in Decision Support System.....	18
3.3 Research Tools.....	20
3.3.1 Artificial Neural Network (ANN).....	20

3.3.2 Symphony General and Special Purpose Template .....	23
Chapter 4: Risk Identification and Assessment .....	25
4.1 Risk Identification.....	25
4.2 Inclement Weather Conditions .....	32
4.2.1 Stochastic Weather Generation Model .....	33
4.2.2 Validation and Modification of Stochastic Weather Generation Model.....	45
4.2.3 Weather Effects on Production and Speed.....	53
4.3 Tire Early Failure .....	69
4.3.1 Model Testing and Validation .....	75
4.3.2 Summary .....	82
4.4 Haul Road .....	83
4.4.1 Introduction.....	83
4.4.2 Haul Road Structure.....	85
4.4.3 Road Maintenance .....	86
4.4.4 Proposed Research Method by Neural Network and Simulation .....	91
4.4.5 Neural Network Testing and Validation .....	96
4.4.6 Simulation Model.....	103
4.4.6 Model Testing and Validation .....	105
4.4.7 Summary .....	108

Chapter 5: Case Study.....	110
5.1 Introduction.....	110
5.2 Project Description and Modeling .....	111
5.3 Testing and Validation.....	114
Chapter 6: Earth Moving Template .....	120
6.1 Introduction.....	120
6.2 Elements.....	121
6.2.1 Source Element .....	121
6.2.2 Placement Element.....	126
6.2.3 Road Element.....	128
6.2.4 Intersection Element .....	129
6.2.5 Cost Parameter Element.....	129
6.3 Inputs and Algorithm .....	130
Chapter 7: Conclusion and Recommendation.....	132
7.1 Conclusion .....	132
7.2 Recommendations.....	133
References.....	135

## List of Figures

Figure 1: Decision Support System .....	20
Figure 2: Example of Artificial Neural Network (Hajjar 1998) .....	22
Figure 3: Example of Neuron (Hajjar 1998).....	22
Figure 4: Excavator Bucket Fill Factor (Caterpillar 1998).....	27
Figure 5: Cycle Time of Different Types of Excavators (Caterpillar 1998).....	28
Figure 6: Truck Performance Diagram (Caterpillar 1998) .....	30
Figure 7: Two-State Markov Chain .....	34
Figure 8: Plot of Actual Means and Periodic Means for Dry Days .....	37
Figure 9: Plot of Actual Standard Deviation and Smoothened Values.....	38
Figure 10: Plot of Maximum Temperature in 1990 and Its Periodic Mean for Dry and Wet Days .....	39
Figure 11: Plot of Periodic Standard Deviation for Wet and Dry Days in 1990 ..	40
Figure 12: Stochastic Weather Generation Model (Wales 1994) .....	44
Figure 13: Modified Probability and Precipitation Distribution.....	47
Figure 14: Comparison between GRNN and 3-Layer Neural Network .....	48

Figure 15: Comparison between GRNN and 3-Layer Neural Network of Standard Deviation.....	49
Figure 16: Weather Generation Test Model .....	50
Figure 17: Mean Values of Predicted Maximum Temperature vs. Historical Values .....	52
Figure 18: Mean Values of Predicted Minimum Temperature vs. Historical Values .....	53
Figure 19: Neural Network for Predicting Production and Speed .....	59
Figure 20: Excavator EX1200 Production Distributions .....	63
Figure 21: Truck 785D Empty Speed Distributions .....	64
Figure 22: Truck 785D Loaded Speed Distributions .....	65
Figure 23: Plot of Actual Production vs. Network Prediction Value .....	65
Figure 24: Plot of Actual Empty Speed vs. Network Prediction Value.....	66
Figure 25: Plot of Actual Loaded Speed vs. Network Prediction Value .....	66
Figure 26: Plot of Minimum Temperature vs. Network Loaded Speed .....	67
Figure 27: Plot of Maximum Temperature vs. Network Loaded Speed.....	68

Figure 28: Plot of Precipitation vs. Network Loaded Speed .....	68
Figure 29: Flowchart of Tire Usage Simulation .....	75
Figure 30: General Symphony Model of Project.....	78
Figure 31: Scenario 1—Project Results With Tire Usage .....	79
Figure 32: Scenario 2—Project Results Without Tire Usage .....	80
Figure 33: Scenario 3—Project Results Without Tire Early Failure .....	81
Figure 34: Influence Diagram of Haul Road .....	84
Figure 35: Cross Section of Haul Road (Tannant and Regensburg 2001).....	85
Figure 36: Plot of Relationship between Maintenance Frequency and Maintenance Cost (Thompson 2003) .....	88
Figure 37: Variables for the LDRDI (Thompson 2003) .....	90
Figure 38: Sample of 3-Layer Artificial Neural Network Used in Haul Road Analysis.....	97
Figure 39: Cost per Maintenance in 1 <sup>st</sup> Neural Network .....	98
Figure 40: Road Deterioration Rate in 1 <sup>st</sup> Neural Network .....	98



Figure 41: Increment of Road Condition after Maintenance in 1 <sup>st</sup> Neural Network .....	99
Figure 42: Fuel Consumption per Truck Load in 2 <sup>nd</sup> Neural Network.....	99
Figure 43: Truck Speed in 3 <sup>rd</sup> Neural Network .....	100
Figure 44: Symphony General Purpose Model for Haul Road.....	105
Figure 45: Continuous Model in General Purpose Simulation Model .....	106
Figure 46: Haul Road Simulation Process in Earth Moving Model .....	109
Figure 47: General Symphony Model for Case Study.....	113
Figure 48: Stochastic Simulation Results .....	117
Figure 49: Simulation Results for 1 Excavator and 7 Trucks.....	119
Figure 50: New Earth Moving Template Elements .....	120
Figure 51: Sample Model of Earth Moving Operations .....	121
Figure 52: Collection of Truck .....	126

### List of Tables

Table 1: Monthly Wet Probability—Historical vs. Predicted.....	51
Table 2: Inputs and Outputs of Neural Network for Excavator Production .....	55
Table 3: Inputs and Outputs of Neural Network for Truck Speed.....	56
Table 4: Fitted Results by @Risk .....	60
Table 5: Errors between Actual Value and Predicted Value .....	62
Table 6: Equipment Properties.....	76
Table 7: Input and Output for 1 <sup>st</sup> Neural Network in Haul Road Simulation Process .....	92
Table 8: Input and Output for 2 <sup>nd</sup> Neural Network in Haul Road Simulation Process .....	94
Table 9: Input and Output of 3 <sup>rd</sup> Neural Network in Haul Road Simulation Process .....	96
Table 10: Sensitivity Analysis of Maintenance Interval.....	101
Table 11: Sensitivity Analysis of Truck Speed.....	102
Table 12: Sensitivity Analysis of Road Condition .....	102
Table 13: Sensitivity Analysis of Precipitation versus Fuel Consumption .....	102

Table 14: Sensitivity Analysis of Precipitation versus Speed .....	103
Table 15: Effects of Maintenance Interval.....	108
Table 16: Soil Type and Quantity .....	111
Table 17: Equipment Performance .....	112
Table 18: Comparison between Traditional Method and Symphony Model.....	114
Table 19: Comparison between Different Types of Bids .....	115
Table 20: General Input of Source Site Element in Earth Moving Template.....	123
Table 21: Collection of Equipment Property in Source Site Element .....	125
Table 22: Input of Placement Element.....	127
Table 23: Input of Road Element.....	128
Table 24: Input of Intersection Element .....	129
Table 25: Input in Cost Parameter Element.....	130

## **Chapter 1: Introduction**

### **1.1 Background**

Earthwork operations are the excavation and movement of different types of soil or rocks to do construction. The earth may be moved and dumped to a predetermined location, or formed into a desired shape for a special purpose, such as the construction of an embankment. Earthwork is one of the main operations of the construction industry. It is involved in most commercial, residential, and industrial construction projects, such as the constructions of building foundations, roads construction, open-pit surface mining, tunnel construction, and dam construction. Especially in road construction and surface mining, earthworks play an important role in project cost and schedule. In road construction, earthworks account for about 25% of the total construction cost (Warren 2011). In surface mining, earth moving operations allocate more than half of the total mining cost (Lashgari 2010). Therefore, for the past few decades, research on earth moving has been ongoing. The main objectives of previous research are to find the best way of modeling the earth moving process, estimating the project duration and cost accurately, and optimizing earth moving operations, which means selecting the most suitable equipment types and equipment combinations for specific projects. In this thesis, research focuses on earth moving operations for surface operations like open-cut excavations and open-pit mining.

## **1.2 Problem Statement**

Real-world earth moving operations are not as simple as they are in theory. Since all earth moving projects are operated in the field, and site conditions and environments are complex, earth moving operations may be greatly affected by the performance of equipment and laborers. Thus, the planning of earth moving projects at the bidding stage is very important. Once companies win the bid and sign the contract, it is difficult to change the plan. The quality of planning will determine whether companies will profit or lose money. Therefore, many methods to assist planning of earth moving projects have been developed through research, such as queuing theory, genetic algorithms, fuzzy logic, and simulation. However, because of the complexity of earth moving projects, and the requirement of related professional knowledge base, many methods for planning earth moving projects are still in the theoretical stage. Most construction companies have relied on spreadsheets for planning and estimating earth moving projects. When planning earth moving projects, companies usually check site conditions like soil profile and topography of construction sites first. Then, based on the projects conditions and requirements, equipment availability, and the companies' bidding strategies, engineers select equipment types and quantities, and estimate the cost and duration of projects. The engineers will also consider inclement weather conditions by adding a few days delay into the estimate.

Both industrial practice and previous research methods lack further research and analysis on the effects of potential risks in earth moving projects, such as inclement weather conditions, early tire failure, haul road conditions, and other potential risks.

For the potential risks of weather conditions, companies only consider severe weather conditions for which all work in the field must be shut down, such as storms, serious fog, and extreme high or low temperatures. In actuality, even if weather conditions are not severe enough to cause site shutdown, they will reduce the performance of construction equipment. Furthermore, the work efficiency of laborers will inevitably decrease if the temperature is too high or too low. Based on those delays, the total delay may be more than what the companies predicted.

The effects of potential risks are mainly reflected in equipment production. For example, excavator production may vary from 1000 BCM/hour to 1500 BCM/hour, based on the combined effects of all potential risks. According to discussions with a professional engineer employed by one of the largest construction companies in Alberta, which is an expert in earthwork, companies just choose a value between 1000 and 1500 as the excavator production, based on engineers' experience and intuition. Even the most experienced engineers in earth moving projects cannot ensure that they will never make a wrong decision, because of a lack of sufficient understanding of risks in the earth moving projects.

Sometimes, construction companies underestimate effects at the bidding stage and this can result in cost or duration overrun.

### **1.3 Research Objective**

Because of the uncertainty of potential risks, they cannot be totally avoided. The only way to try to avoid overruns is to clearly understand the effects of those risks on the equipment performance and the whole project, and for construction companies to realize the probability that they can complete the project within the estimated time. Then, companies can adjust their plan, and make a proper decision at the bidding stage based on their risk tolerance and bidding strategies. Therefore, the objective of this research is to create a decision support tool for earth moving planning at the bidding stage using two useful tools, Symphony.NET and artificial neural network, to model the earth moving operations, and analyze the effects of the main risks identified in most earth moving projects. The main risks are weather conditions, early tire failure, and haul road conditions. The proposed decision support system aims to provide a guideline for construction companies to analyze project risks based on their own data. Then, companies can quickly and precisely plan earth moving projects and decide the bid price based on the risk analysis, market state, financial statements, and the companies' own bidding.

## 1.4 Thesis Organization

This thesis is divided into seven chapters to discuss the research methods and outcomes in detail, and finally provide some suggestions for future research. The following is a brief introduction of each chapter.

**Chapter 1:** briefly introduces the background of earthworks, states the problems currently encountered by construction companies, and outlines the research.

**Chapter 2:** provides a literature review of earthwork operations. It first introduces the research history of earthworks: methodologies and objectives of past research. Then, the risks analysis methodologies used in the construction industry are introduced. Finally, Monte Carlo simulation, which has been used in both earthworks operation research and risk analysis, is discussed.

**Chapter 3:** introduces the research methodologies in detail. Artificial neural network and Symphony.NET will be discussed.

**Chapter 4:** outlines risk analysis in earthwork operations. First, the chapter identifies what risks exist in earth moving operations and what risks are important and need to be analyzed, based on the historical data and the methodologies used. Then, artificial neural network and Symphony.NET are used to try to quantify the effects of those risks on the equipment performance and the whole project.



**Chapter 5:** introduces the methods of modeling the earth moving process and doing risk analysis using Symphony general purpose template. A case study is presented to explain the risk analysis method.

**Chapter 6:** introduces the earth moving template, which can help industry people model different earth moving scenarios and provide the simulation results of total project duration and direct cost. The earth moving template is a Symphony special purpose template, which is much more user friendly than the general purpose template. The validation of the earth moving template is done by comparing it to the general template.

**Chapter 7:** summarizes the research and provides some recommendations on future research on earthworks.

## **Chapter 2: Literature Review**

### **2.1 Introduction**

Earthwork operations are complex to plan, due to their nature and working environment, especially for large projects like surface mining, dam construction, and road construction. Quality planning of earthwork operations at the bidding stage can help the contractor manage crews in the construction process, and make sure the project finishes within budget. Thus, during the past few decades, many researchers have investigated a good method of planning earthwork operations to minimize cost and ensure the production required. Generally, the procedures of planning an earthwork project can be summarized as 4 steps. First, excavated and dumped earth volumes must be calculated. Second, dump locations must be selected. Third, based on the earth volumes, dump locations, and proposed finished date, earth moving equipment is selected. Finally, the estimated duration and cost are calculated according to the properties of the selected equipment. During the planning process, the key procedure is selecting equipment, as it determines the productivity of the project. Therefore, most of the previous research is focused on finding the best equipment types and combinations, which will optimize the whole earthwork operation.

## 2.2 Earth Moving Operations Planning Methodologies

### 2.2.1 Industrial Practice

Currently, industrial companies use spreadsheets incorporated with integer programming and match factors to plan earth moving operations (Fayyad 2012). Engineers in construction companies use equipment manufacturer standard tables and charts to find equipment types and their related properties such as speed, production, and capacities, which are used to estimate duration and cost of the operation. Since the equipment properties from the manufacturer are estimated under ideal situations, the real values usually have a few differences. In order to make sure the estimated results more closely reflect real situations, sometimes companies will use their collected historical data. Integer programming is a mathematical optimization program in which some or all of the variables are restricted to integers. In earthwork planning, the variables in the integer programming are restricted by project duration, budget, and so on. Match factor is a method used to measure how well the loading equipment and hauling equipment match. It was proposed by Morgan and Peterson (1968). The match factor is calculated by the following equation:

$$\text{Match Factor} = \frac{\text{Number of Trucks} \times \text{Excavator Cycle Time}}{\text{Number of Excavators} \times \text{Trucks' Cycle Time}}$$

Theoretically, the excavators and trucks are perfectly matched if the match factor equals 1. When the match factor is smaller than 1, it means that more trucks are

needed. When the match factor is larger than 1, it means that the idleness of the trucks increases.

Industrial practice in earth moving planning requires engineers to combine methods with their own work experience in earth moving operations. This method has some defects. For example, when calculating the truck cycle time, the truck waiting time is usually not considered.

### **2.2.2 Previous Research in Supporting Earth Moving Planning**

Since many uncertainties affect the earthwork operation, which increases the complexity of planning, many researches have investigated ways of supporting earth moving planning. The main objective of previous research is to optimize earth moving operations. In the past decades, many methods have been applied in selecting equipment types and equipment combinations, which aim to maximize the productivity, and minimize the cost. The methods that are mainly used in earth moving research are linear regression, AHP, fuzzy logic, expert system, genetic algorithms, queuing theory, and simulation.

#### ***2.2.2.1 Linear Regression***

Morgan and Peterson (1968) recognized that the bunching factor will affect the accuracy of earth moving productivity estimation while they worked on shovel-truck productivity estimation at Caterpillar. In order to solve the problem of accurate estimation of earth moving productivity, Smith (1999) developed a

deterministic model. By investigating the results obtained from over 140 separate earth moving operations taken from four different highway construction projects, Smith found that there was a strong linear relationship between operating conditions and productivity. Finally, he derived a multiple linear regression model for determining the actual productivity. However, the linear regression model is not suitable for all situations. It is restricted for only one loader, and it may overestimate productivity for operations that are particularly over-resourced or under-resourced (Smith 1999).

#### ***2.2.2.2 AHP & Fuzzy Logic***

AHP, analytical hierarchy process, was first introduced by Saaty in 1980. It is a good method for dealing with complex economic, technological and sociopolitical problems. The main advantage of AHP is its inherent capability to deal with a large amount of intangible and non-quantifiable variables. Fuzzy logic has similar capabilities to AHP. It can easily handle linguistic variables. Therefore, in recent years, some researches have applied AHP and fuzzy logic to large earth moving operations, such as surface mining, for equipment selection. In 2005, Shapira presented an equipment selection model based on AHP, which is a multi-attribute decision analysis method. It resulted in solving two issues: the systematic evaluation of soft factors (i.e. qualitative, intangible, informal), and the weighting of soft benefits in comparison with costs (Shapira 2005). Bazzazi developed a fuzzy multi criteria decision making model for open pit mine equipment selection

(2011). Use of both AHP and fuzzy logic requires experts in earth moving operations. The experience of experts will greatly affect the results. Therefore, AHP and fuzzy logic are not reliable for practical use.

### ***2.2.2.3 Artificial Intelligence Techniques***

As computer technologies are quickly developing, computer-aided technologies have been developed for optimization of earth moving operations. Artificial intelligence is one of those computer-based technologies. There are three commonly used artificial intelligence techniques: genetic algorithms, neural network, and expert system.

Expert system is most commonly used to select equipment types and quantities in surface mining. Inference engine and knowledge base are the main parts of an expert system. The explanation unit, user interface, and knowledge acquisition are the rest of the parts. A prototype computer program called ESEMPS was developed by Alkass (1988). It is an expert system for earth moving equipment selection in road construction. In 2009, another expert system was developed by Kirmanli and Ercelebi within KappaPC shell. This expert system supports object-oriented technology for MS Windows environment. It aimed to select hydraulic excavators and trucks for surface mining. Some other expert systems have been developed for specific objectives. Expert system is a powerful tool, but it still has some shortages. The disadvantage of expert system is that development of the knowledge base is time consuming. Further, some parts of the knowledge base are

constructed based on the experience of professional engineers in earth moving operations. Different engineers will have different opinions when dealing with similar issues according to their experience, so it is difficult to unify all opinions in the knowledge base to fit all situations.

Genetic algorithm is another artificial intelligence method used in earth moving optimization. Genetic algorithms are adaptive heuristic search algorithms based on the evolutionary ideas of natural selection and genetics. The nature of genetic algorithms provides them the capability of solving optimization problems. It is usually combined with other methodologies to perform two functions, namely, earth moving equipment selection and cost optimization. In 1999, Haidar and his partners developed a decision support system XpertRule for the selection of opencast mining equipment (XSOME), which was designed using a hybrid knowledge-based system and genetic algorithms. In 2002, Marzouk and Moselhi applied genetic algorithms, working together with a simulation engine (EMSP), to optimize the total cost of earth moving operations, accounting for the equipment models available to contractors. Genetic algorithm is a good optimization tool, but it requires users to have in-depth related knowledge. Therefore, it is not practical for construction companies to use.

Neural network is not commonly used in earth moving research. In 1996, Kartam tried to use neural network to select dozer/scrapper combinations. He used the simulation model to generate the training data for the neural network. However,

training neural networks requires a large amount of data, and the accuracy of training data will affect the accuracy of the trained neural network. Therefore, developing a neural network to directly predict optimized equipment combinations is not a good option.

#### ***2.2.2.4 Queuing Theory***

In selecting near optimal equipment fleets, most of the above methodologies have a similar defect, which is ignoring the uncertainty of duration of activity times in earth moving. There are two methods that can take the variation of durations into consideration and model the construction process closer to reality. Queuing theory is one of those. In 2002, a computer module called FLSELECTOR, representing FLEET SELECTOR, was developed for selecting a fleet of equipment with the minimum cost, maximum production, or minimum duration (EI-Moslmani and Alkass 2002). It applies queuing theory, and focuses on selecting a multi-loader and multi-truck fleet. However, there are also some limitations of FLEET SELECTOR. First, the number of loaders is limited to three. Second, the system assumes that no queuing will occur at the dumping point, so that haulers have to wait at the loading system (EI-Moslmani and Alkass 2002).

#### ***2.2.2.5 Simulation***

Simulation is another method that can imitate the operations of a real-world process over time. It is widely used in scientific research. Construction simulation



is unique because of the complicated systems involving very complex components, a large number of tasks and resources, and uncertainties (Shi and AbouRizk 1994). Discrete event simulation has been proven to be a useful tool for modeling construction operations including earth moving operations. In the 1960s, a simulation language, GPSS was introduced for simulation application in the construction area, which gave a new approach for generality and convenience of direct modeling by providing a set of predefined concepts. Then in the 1970s and 1980s, many other simulation languages were created based on GPSS such as SIMSCRIPT, GPSS/H, SLAM, and SLMAN (Oloufa 1993).

The major advancement of construction simulation began after the development of CYCLONE (Halpin 1977; 1990). CYCLONE simplifies and facilitates the use of simulation in construction (AbouRizk and Hajjar 1998). In the following years, many other simulation tools were developed based on the advancement that CYCLONE introduced. Symphony is one of those successful simulation tools, developed by Hajjar and AbouRizk (1999).

Earth moving simulation is a major research area in construction simulation, which leads to the concept of special purpose simulation. General purpose simulations, such as CYCLONE, require industry practitioners to spend a lot of time building the model with a program language that is not familiar for them. On the contrary, special purpose simulation is designed for the practitioners who have knowledge related to the construction area, but not to simulation, to model a

project conveniently (AbouRizk and Hajjar 1998). Some special purpose simulation tools have been developed for modeling and optimizing earth moving operations. AbouRizk and Shi (1995) developed an automated earth moving simulation model, AP2\_EARTH. The simulation model can be automatically built based on the project and resource information input by users. In 2002, a framework called SimEarth was developed for planning and optimizing earth moving operations (Marzouk 2003). It was designed as a special purpose simulation tool in the Microsoft environment.

Sometimes researchers combine simulation with other methods for better estimations and optimization. SimEarth uses genetic algorithms, in cooperation with a simulation engine, for multi-objective optimization of earth moving operations (Marzouk and Moselhi 2004). Xu (2001) integrated 3D-CAD and simulation modelling to provide real-time analysis and improve the accuracy of discrete event simulation modelling. Simulation is still the main tool used in earth moving research.

### **2.3 Risk Analysis in Construction Engineering**

“No construction project is risk free. Risk can be managed, minimized, shared, transferred, or accepted. It cannot be ignored” (Latham 1994). Many potential risks, such as weather conditions, or early tire failure, are present during earth moving operations. These risks affect final project costs and durations. Risk

analysis is the main objective in this research. In order to achieve this research objective, literature was reviewed to find a suitable method for analysis.

Risk analysis is one of the main research topics in construction management, and has existed for a long time. It started in the 1950s with the development of program evaluation and review technique (PERT) for tackling uncertainties in project duration (Taroun 2013). Many tools and theories have been created and used in risk assessment and management, such as probability theory, Monte Carlo Simulation, fuzzy set theory, influence diagram, AHP, utility theory, and cognitive argument.

#### **2.4 Monte Carlo Simulation**

Monte Carlo simulation was first developed by a group of scientists involved in the Manhattan Project, which was nuclear weapon research that took place in Los Alamos Scientific National Laboratory in the 1940s (Metropolis and Ulam 1949). It is a computerized mathematical technique that allows people to account for risk in quantitative analysis and decision making. It is widely used in finance, energy, manufacturing, project management, insurance, transportation and so on. Monte Carlo simulation based risk analysis in construction management was first employed in the 1970s (Edwards and Bowen, 1998). Since the probability and impact of each risk in the earthmoving projects is difficult to assess, Monte Carlo simulation becomes a useful method in analyzing the risks' impact on the project by calculating the project completion probability.

## **2.5 Summary**

Through literature review it was found that many useful methods have been developed, such as queuing theory, expert system, fuzzy logic, and simulation. All of the methods that are used in previous research aim to model the earth moving process well, estimate the project duration accurately, and optimize earth moving operations. Little research has been done to discuss the risk effects in earth moving operations. Since Simphony general purpose template and special purpose template can both model the earth moving process, and handle the Monte Carlo simulation, it was chosen as one tool to achieve the research objective in this thesis.

## **Chapter 3: Research Methodology**

### **3.1 Introduction**

The research objective of this thesis is to develop a decision support system for planning earth moving operations at the bid stage, which can accurately model the earth moving process, estimate the total direct cost, and analyze the effects of risk in earth moving operations. The components of the decision support system and the research tools used are introduced here.

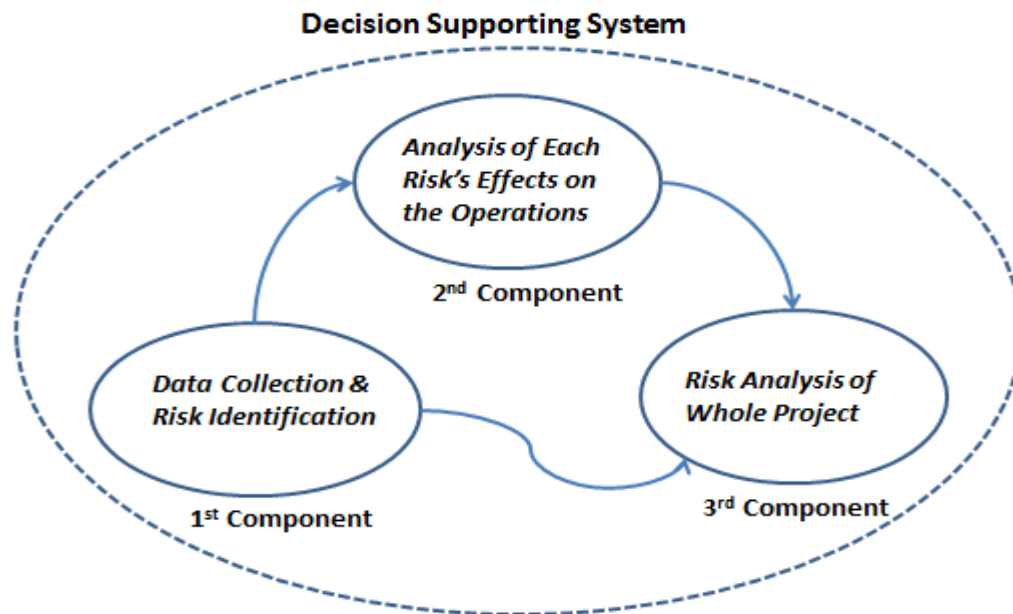
### **3.2 Components in Decision Support System**

The decision support system is shown in Figure 1. There are three components interacting with each other in the decision support system.

The first component of the support system is risk identification and data collection. Before doing any risk analysis, the risks that may exist in the earth moving projects should be identified. Then, based on the identified risks, the data that need to be used in risk analysis should be collected.

The second component of the support system is assessment of identified risks. Most risk will affect equipment performance, and therefore, the whole project duration and cost. Artificial neural network and Symphony general purpose template are used to do the risk assessment in the second component.

The third component of the support system is risk analysis of the whole project. The risks existing in the earth moving operation will affect the project duration. Monte Carlo simulation is used to generate the project completion probability. In combination with the risk assessment results in the second component, the effects of each risk on the whole project duration and cost can be analyzed. The Symphony general purpose template will be the most important research tool for the third component. Symphony general purpose template can handle discrete event simulation, which is a good tool to model the earth moving process. In addition, the general purpose template can do Monte Carlo simulation. The stochastic input of operation production can be directly generated from the historical data sets from the first component, or from the neural network developed in the second component. A Symphony special purpose template is developed for the earth moving operations. It can help industry practitioners model the earth moving process and do Monte Carlo simulation without related knowledge.



**Figure 1: Decision Support System**

### 3.3 Research Tools

There are two research tools used in developing the decision support system: artificial neural network and Symphony.NET.

#### 3.3.1 Artificial Neural Network (ANN)

Artificial neural network (ANN) was chosen to analyze the effects of risks on the productivity. Since the risks in earth moving operations are complex and interrelated, it is difficult to analyze each risk individually. However, the characteristics of artificial neural network make it a good approach for this complex problem.

Artificial neural networks are algorithms that can perform linear or non-linear statistical modeling and provide a new alternative to logistic regression (Tu 1996). Artificial neural networks are computational models inspired by an animal's central nervous system, which is capable of machine learning and pattern recognition. It is a good method for developing predictive models. Neural networks have many advantages. For example, they can detect the complex nonlinear relationships between different variables, and are able to detect all possible interactions between predictor variables (Tu 1996).

Artificial neural networks are comprised of a set of nodes, and connection between nodes. The nodes in the network are called artificial neurons, which are computational models. The artificial neurons are modeling the working theory of natural neurons in the network. They receive information, handle the received information in a specific way, and finally generate output information. The working theory of artificial neurons is shown in Figure 3. The neurons basically consist of inputs, which are multiplied by weights, and then computed by a mathematic function which determines the activation of the neurons. Finally, the activation function computes the output of neurons. The simplest artificial neural networks are made up of three layers: input layer, hidden layer, output layer, as illustrated by Figure 2. The trained neural network will be used to analyze the effects of risks on the production and speed, and then work with a simulation model by generating the stochastic inputs. This method was first introduced by Hajjar and AbouRizk (1998).



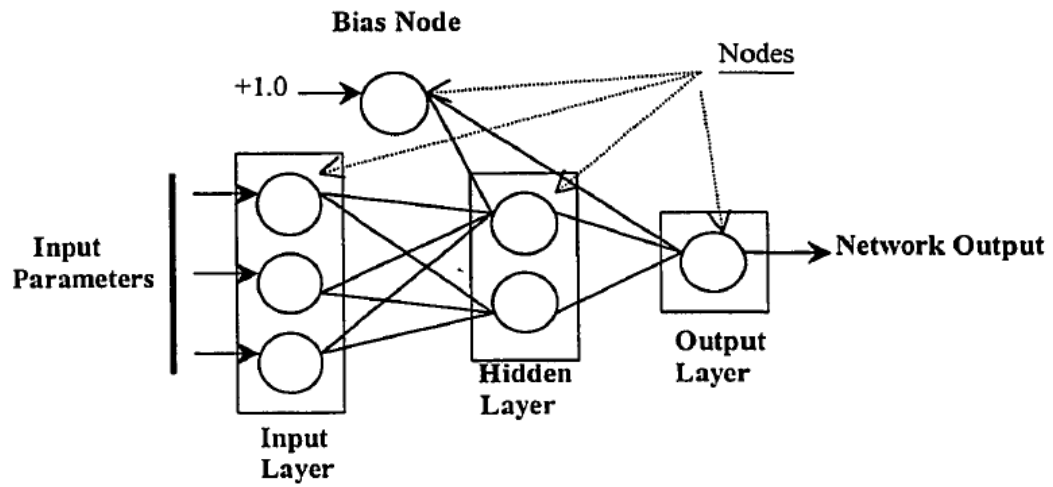


Figure 2: Example of Artificial Neural Network (Hajjar 1998)

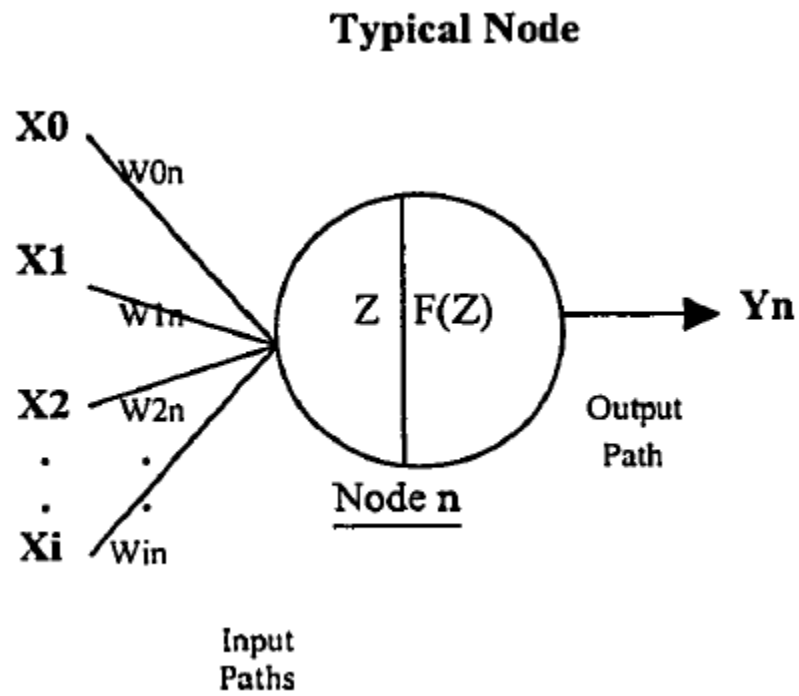


Figure 3: Example of Neuron (Hajjar 1998)

### **3.3.2 Symphony General and Special Purpose Template**

Simphony.NET is a key tool in the decision support system, as it can model earth moving operations and do further analysis of risk in the operations. Simphony is a simulation tool for hierarchical modeling developed by Hajjar and Abourizk (1999). In 2002, AbouRizk and Mohamed developed Simphony.NET based on Simphony. Simphony.NET consists of a foundation library, as well as specialized computer programs that allow for the development of new construction tools in an efficient manner. Simphony.NET provides users easy access to simulate specific construction process without requirement of any simulation knowledge. The main model building block in Simphony.NET is the modeling element. When building a model, users create instances of modeling elements that resemble real components of a construction system, and connect the elements together in ways similar to those in the real systems.

Simphony.NET can support both general purpose simulation and special purpose simulation. The Simphony general purpose template (GPT) can model different kinds of construction processes including earth moving operations. The GPT requires users to have knowledge of both the related construction process and of simulation. The Simphony special purpose template (SPT) is more user friendly. The SPT is developed for modeling a specific construction process. It doesn't require users to have simulation knowledge, so it is convenient for industrial practitioners to use. Many useful Simphony special purpose templates have been

developed. The tunneling template can model the process of tunnel construction. The PERT template can be used to do risk analysis of construction schedule. The reclamation template can be used to model the reclamation process in earth moving projects. There is an original earth moving template, which can model the simple earth moving process of excavate, prepare, load, haul, dump, spread and compact. It cannot model other types of earth moving processes. Therefore, a new earth moving template was developed in this research that can cooperate with neural network, and model more types of earth moving processes.

## **Chapter 4: Risk Identification and Assessment**

### **4.1 Risk Identification**

Since work environments of earth moving operations are complex and full of variations, there are many uncertainties in earth moving projects that can affect the productivity and cost. Equipment and human resources are the two most important components in earth moving operations.

There is a lot of equipment developed for different construction purposes. In earth moving operations, excavators, shovels, dozers, loaders, trucks, and compactors are commonly used. These are responsible for excavating, loading, hauling, dumping, spreading, and compacting. Not all types of equipment are required in every earth moving projects. The most frequently used types of equipment are excavators, trucks, and dozers.

Through review of previous research, it can be noted that excavators and trucks have the greatest influence on the productivity of earth moving operations. Thus, many researchers have tried to find the best combinations of excavators and trucks for specific projects so that they can reduce either the bunching effects or the idleness of excavators. Many useful methods have been developed to find an optimized equipment fleet size, but they still cannot make sure the optimized equipment fleet can perform as desired. It still has a certain probability of exceeding the planning results because of the risks in the operations.

When planning simple excavator-hauler earth moving projects, industrial engineers calculate the productions of the excavators and the speed of haulers by checking the performance manuals or charts from the equipment factories. By reviewing the equipment performance tables and charts from Caterpillar, it can be found that the productions of excavators and trucks' speed cannot remain constant throughout the project, as planned at the bidding stage. The uncertainties will affect the performance of the equipment. The production of an excavator, given in the Caterpillar Performance Handbook (1998), is calculated by the following equations:

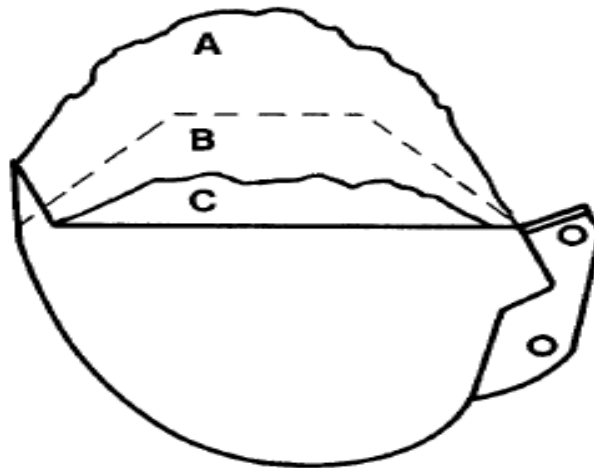
*Actual Production*

$$= \frac{60 \text{ min/hr}}{\text{Cycle Time} - \text{min}} \times \text{Avg. Bucket Payload in } m^3 \\ \times \text{Job Efficiency Factor}$$

*Avg. Bucket Payload = Heaped Bucket Capacity × Bucket Fill Factor*

The bucket fill factors from the Caterpillar Performance Handbook (1998) are shown in Figure 4.

Material	Fill Factor Range (Percent of heaped bucket capacity)
Moist Loam or Sandy Clay	A — 100-110%
Sand and Gravel	B — 95-110%
Hard, Tough Clay	C — 80-90%
Rock — Well Blasted	60-75%
Rock — Poorly Blasted	40-50%



**Figure 4: Excavator Bucket Fill Factor (Caterpillar 1998)**

The cycle time of an excavator can be chosen from Figure 5 below.

CYCLE TIME ESTIMATING CHART																
CYCLE TIME	MACHINE SIZE CLASS														CYCLE TIME	
	307	311B	312B	315B	318B L*	320B	322B	325B	330B	345B*	350	375	5130B ME	5230 ME		
10 SEC.																0.17 min.
15																0.25 min.
20 SEC.																0.33 min.
25																0.42 min.
30 SEC.																0.50 min.
35																0.58 min.
40 SEC.																0.67 min.
45																0.75 min.
50 SEC.																0.83 min.
55																0.92 min.
60 SEC.																1.0 min.

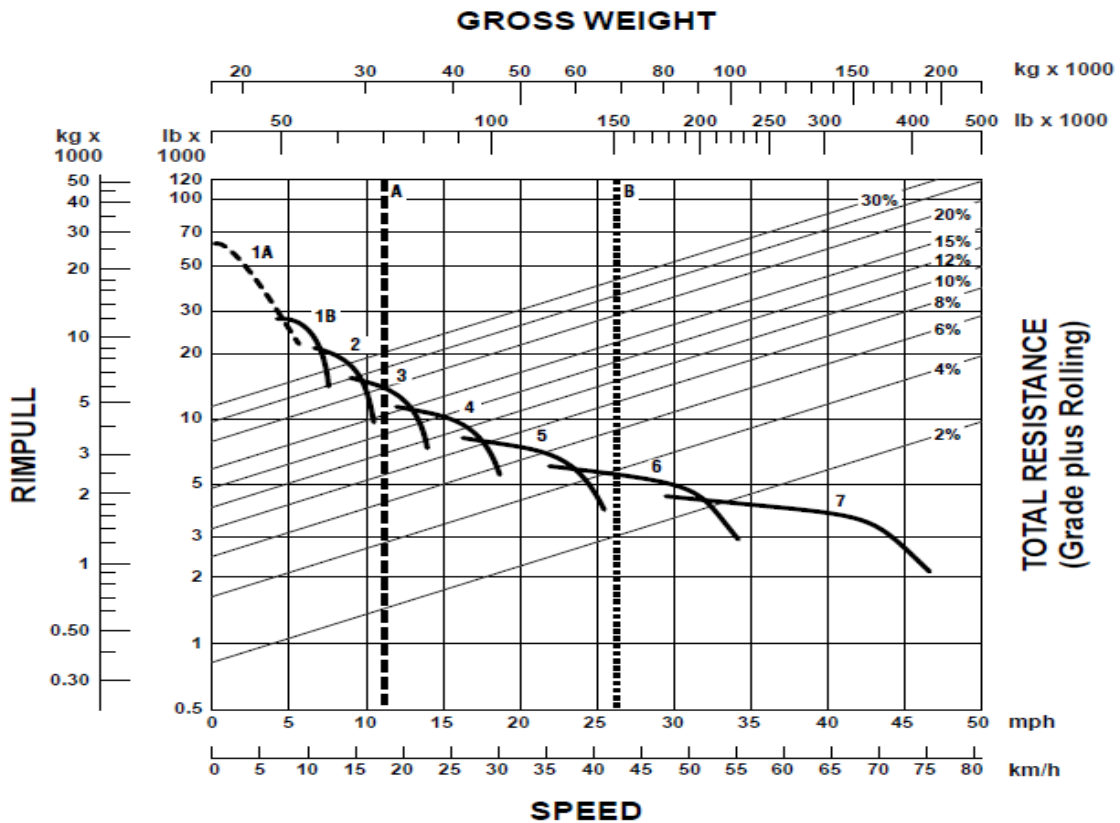
**Figure 5: Cycle Time of Different Types of Excavators (Caterpillar 1998)**

From Figure 4, it can be found that different soil types will have different fill factors, which will affect the actual production of the excavator. Even with the same soil type, the fill factor is not constant. The job efficiency factor is determined by operators and equipment conditions. The cycle time of the excavator is comprised of loading the bucket, swinging loaded, dumping the bucket, and swinging empty. The cycle time of the excavator is dependent on the machine size and the job conditions. The fastest possible cycle time occurs when digging unpacked earth, with a digging depth of less than 40% of the machine's maximum depth capacity, and the swing angle less than  $30^{\circ}$ . The slowest possible cycle time occurs when digging tough earth such as sandstone, shale, and hard frost, with a digging depth of over 90% of the maximum depth capacity, and a

swing angle over  $120^{\circ}$ . Figure 5 lists the ranges of cycle time for 12 different Caterpillar excavators. Soil types, swing angle, loading positions, soil conditions under the excavator, conditions of equipment, and operator's skill are all possible risks to the production of the excavator.

Haulers' speed is another factor that determines productivity of earth moving projects. Drivers cannot keep the haulers in a constant speed. In addition, in consideration of accelerating and decelerating, the speed of a truck is full of variation. Caterpillar Performance Handbook (1998) provides a performance chart for different types of trucks. The following figure is a performance chart for truck 769D with 18.00R33 tires.





**Figure 6: Truck Performance Diagram (Caterpillar 1998)**

By calculating the gross weight and the total resistance, people can check the maximum speed of truck 769D and its rim pull. Here, it can be observed that gross weight and total resistance will affect the travel speed. Gross weight is determined by truck weight, the capacity of trucks, and the loose density of soils loaded. The total resistance will be much more complicated. Many factors can affect the total resistance. Generally, the total resistance is calculated by the summation of rolling resistance and grade resistance. For uphill, the grade resistance will be positive; while for downhill, the grade resistance will be

negative. For earth moving operations in the city, the total resistance will be easy to measure. In contrast, for earth moving projects operating in the field, the site conditions may limit the haul road design. The haul road conditions will be much worse than paved roads in the cities, so that the grade and rolling resistance will be variable and difficult to determine. What's more, precipitation and tire conditions will affect the performance of trucks as well.

Some of the risks' impacts have been classified and analyzed in the previous researches. For example, in the construction industry, the rules of thumb for finding the best capacity of truck for fitting the selected excavator is that four or six passes of an excavator can fill up the trucks. However, the soil types can impact this industrial rule of thumb. Based on the research done by Morley (2013), small excavators paired with large haulers lead to the lowest direct costs when excavating and loading light cover soil material, even though it will exceed 6 passes. There are still some other important risks during earth moving project that have not been analyzed yet. Therefore, it is observed that inclement weather conditions, tire early failure, and haul road conditions are three main potential risks to earth moving operations. The rest of the thesis will analyze these three risks in detail. The proposed methodologies of quantifying the effects of these risks on the equipment production and speed will be explained. The effects of uncertainties in total project duration and cost can be done by implementing Symphony GPT, which will be introduced in Chapter 5. Due to the limitation of historical data, some research methodologies are still in the conceptual stage.

## **4.2 Inclement Weather Conditions**

Since most earth moving projects take place in exposed fields, weather conditions will have more obvious effects on these operations. The weather conditions include temperatures, precipitation (rain, snow), wind, humidity, and visibility. People cannot work in extreme hot or cold temperatures. The construction equipment will also be affected by the temperature. When the temperature is high, engines and tires will overheat quickly, while in low temperatures, lubricants will be stickier which will reduce the performance of the engine and transmission system. Precipitation, especially large amounts of precipitation, such as snowstorms, will reduce visibility and rolling resistance of haul roads. The wind will affect some construction operations.

In industrial practice, companies only consider weather risks as shutdowns caused by severe weather conditions. Obviously, the effects of weather conditions are more than that. In order to analyze the impacts of inclement weather conditions on equipment performance, and project durations, a stochastic weather generation model which can accurately predict the weather conditions and neural networks for predicting equipment performance are necessary. The neural networks can be used to analyze the impacts of weather conditions on equipment performance, and the stochastic weather generation can work with neural networks to provide equipment production and speed in earth moving simulation. The generated

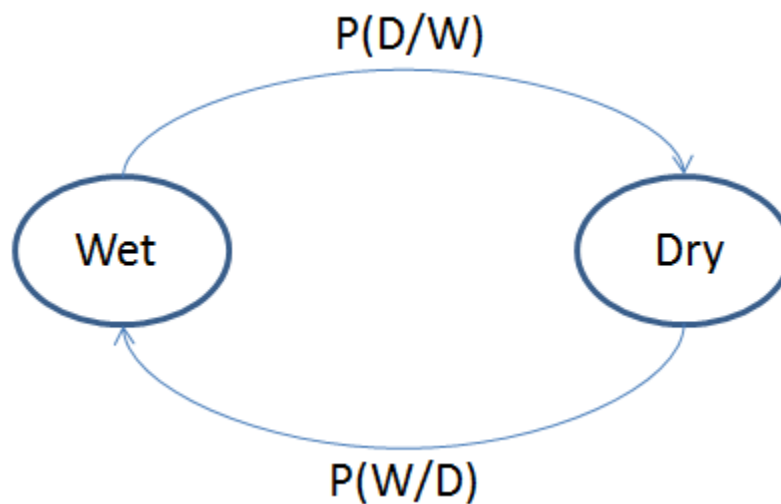
stochastic production and speed will be more close to the real scenarios so that it will increase the accuracy of simulation results.

#### **4.2.1 Stochastic Weather Generation Model**

In the past few decades, many methods have been developed for predicting the weather conditions. Smith and Hancher (1989) applied a Markov process in predicting precipitation. Kavvas (1977) and Katz (1985) showed that first-order Markov chains are successful methodologies in meteorological applications. In order to model and analyze weather effects on earth moving operations, a weather conditions predicting tool is necessary. Through review of previous work, a stochastic weather generation model developed by Wales (1994) was found to be applicable in this research. Some modification of that model was done for better prediction.

The stochastic weather generation model developed by Wales (1994) is a modification of the process described by Richardson (1981). A historical data set is analyzed to determine the stochastic structure of the meteorological process, which is then used to generate weather variables for future dates. The Markov process (Smith and Hancher 1989) is selected for modeling precipitation. A two-state (wet, dry) first-order Markov Chain is used, as shown in Figure 7. The wet is defined as a day in which 0.2 mm or more precipitation has fallen. Days which have less than 0.2 mm precipitation can be considered as day. Minor precipitation has little effect on construction operations. The transitional probabilities are

determined based on historical records of precipitation for each month to reflect seasonality. The Markov chain operates by considering the status of the current day first. The precipitation status of the following days can be determined based on the previous days' status, and the transitional probabilities of changing from state to state.  $P_m(w)$  is the probability of wet days in a month.  $P_m(w/d)$  is a transitional probability of wet days for which the previous day is dry in a month.  $P(w/w)$  is also a transitional probability of wet days for which the previous day is wet as well in a month.



**Figure 7: Two-State Markov Chain**

In wet days, the precipitation amount must be determined. The precipitation amount for a wet day is calculated by randomly sampling an amount from a probability distribution fit to the related month, which is generated from historical records. In order to reflect the seasonality of precipitation, the probability

distribution is selected for each month based on the historical data set. The K-S test is done for selecting the best fit distribution. Both moment matching and maximum likelihood methods are used for doing the K-S tests. The best fit probability distribution will be chosen by comparing the K-S tests' results generated from two different methods.

The maximum and minimum temperatures are two weather conditions that will be generated in Wale's stochastic weather generation model. It utilizes the weakly stationary generating process suggested by Matalas (1967). It is a stochastic process, which maintains the dependence between weather variables on the same day and from day to day. Generating maximum and minimum temperatures using this method requires analysis of the time dependence and independence structures through historical records.

There are two steps in utilizing the weakly stationary process. The first step is to reduce the historical weather data sets into residual elements. This step is for normalizing time series data by removing means and standard deviation of weather variables (Yevjevich 1972). For generating the residual elements, the daily mean and standard deviations of the historical data set should be calculated first based on the precipitation status of the day. Therefore, four series of means and standard deviation will be generated for each weather variable: mean for dry days, mean for wet days, standard deviations for dry days, and standard deviations for wet days. Then, these means and standard deviations series need to be

smoothed to obtain periodic means and standard deviations. Finally, a time series of residuals elements will be generated by removing the periodic means and standard deviations from actual values. The residual elements are calculated by the following equations:

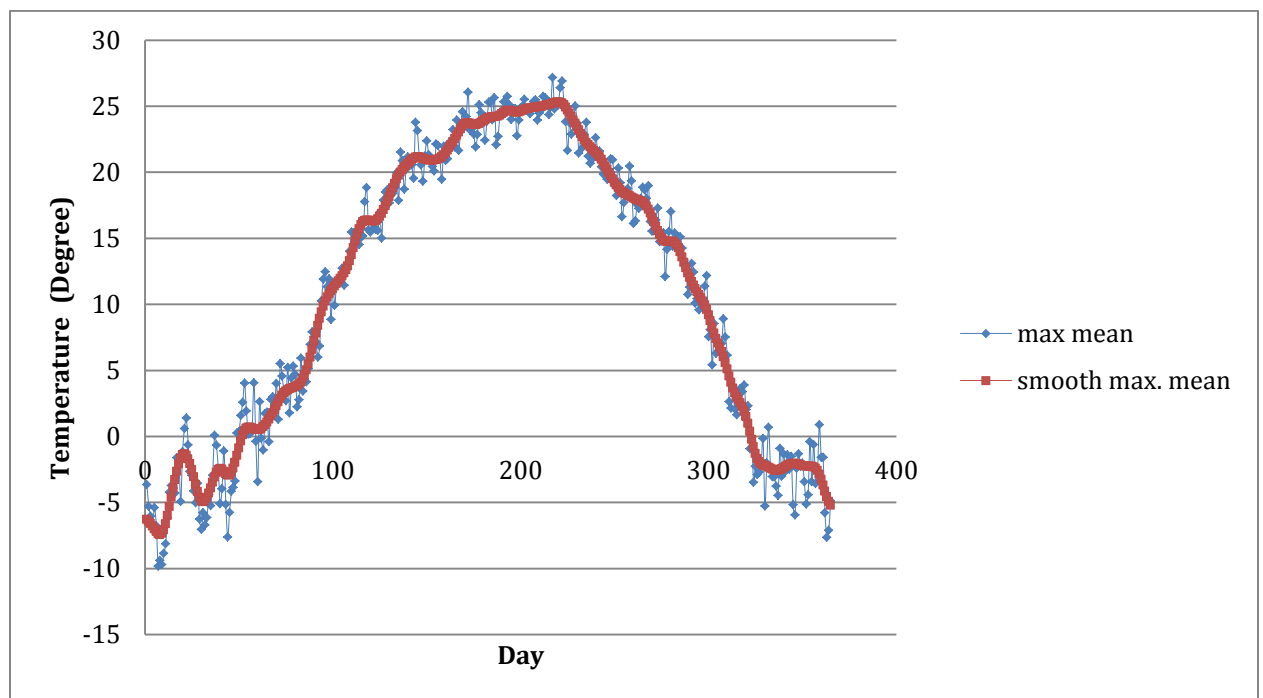
$$x_i = \frac{X_i - \bar{X}_i}{\sigma_i}, \text{ at } P_i < 0.2 \text{ mm} \dots \dots \dots (1)$$

$$x_i = \frac{X_i - \bar{X}_i}{\sigma_i}, \text{ at } P_i \geq 0.2 \text{ mm} \dots \dots \dots (2)$$

$x_i$  is the residual element of the temperature variable.  $X_i$  is the actual value of variable  $i$ .  $\bar{X}_i$  and  $\sigma_i$  are the periodic mean and standard deviation of variable  $i$ .

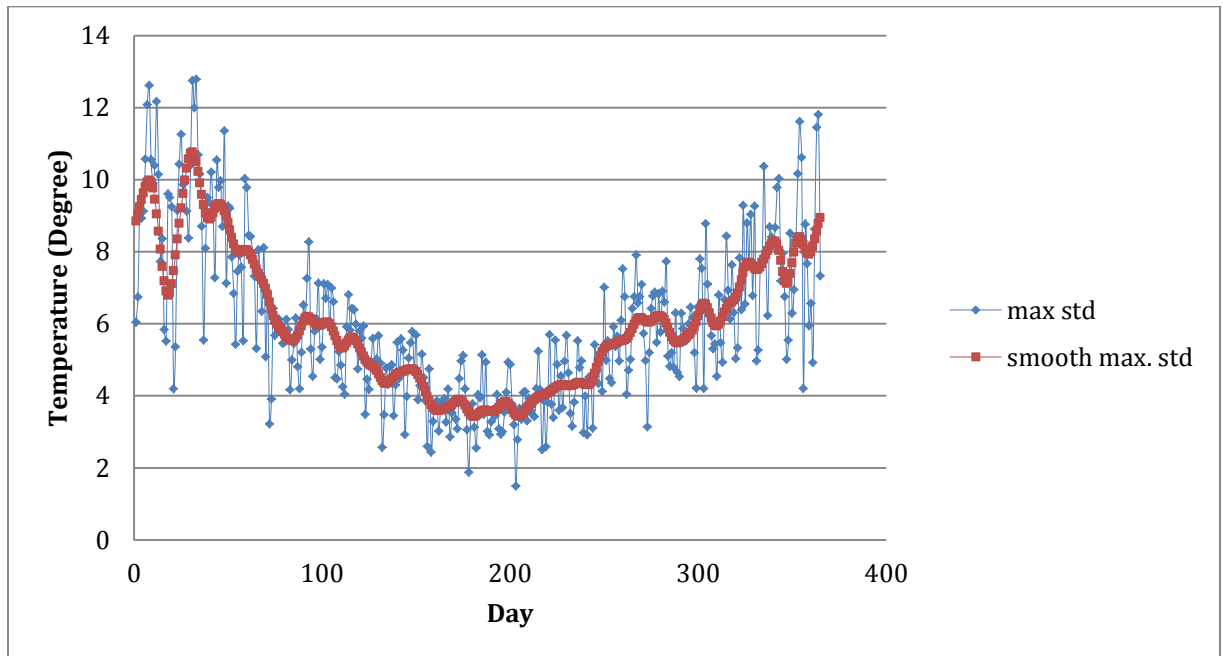
The following figures are plotted by applying the procedures in the first step of weakly stationary generating process. The 20 years of historical weather data from 1972-1991 recorded at Edmonton Municipal Airport weather station are used in analysis. Figure 8 is a plot of mean values for dry days and the periodic means. The general regression neural network (GRNN) is suggested to obtain the periodic means and standard deviations. Software called NeuroShell 2 is used for applying the general regression neural network. The NeuroShell 2 is a useful and convenient tool for users to build and train different types of neural networks. Figure 9 is a plot of actual standard deviations and periodic standard deviations. Figure 10 is a plot of actual daily maximum temperatures recorded in 1990 in the Edmonton area, together with periodic means of maximum temperatures for dry

days and wet days. Figure 11 is a plot of periodic standard deviations of maximum temperatures for dry days and wet days. Figure 12 is a plot of residual elements for maximum temperatures, which is generated by subtracting the periodic mean of maximum temperature from actual temperature, and then dividing by the periodic standard deviation based on the precipitation status of the day.

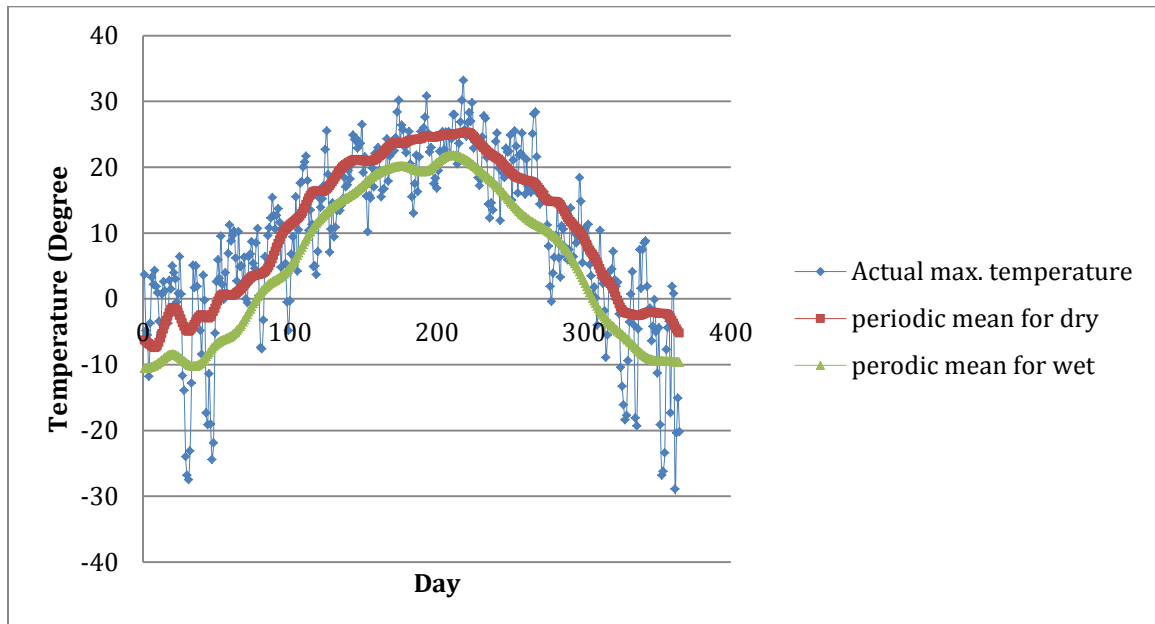


**Figure 8: Plot of Actual Means and Periodic Means for Dry Days**

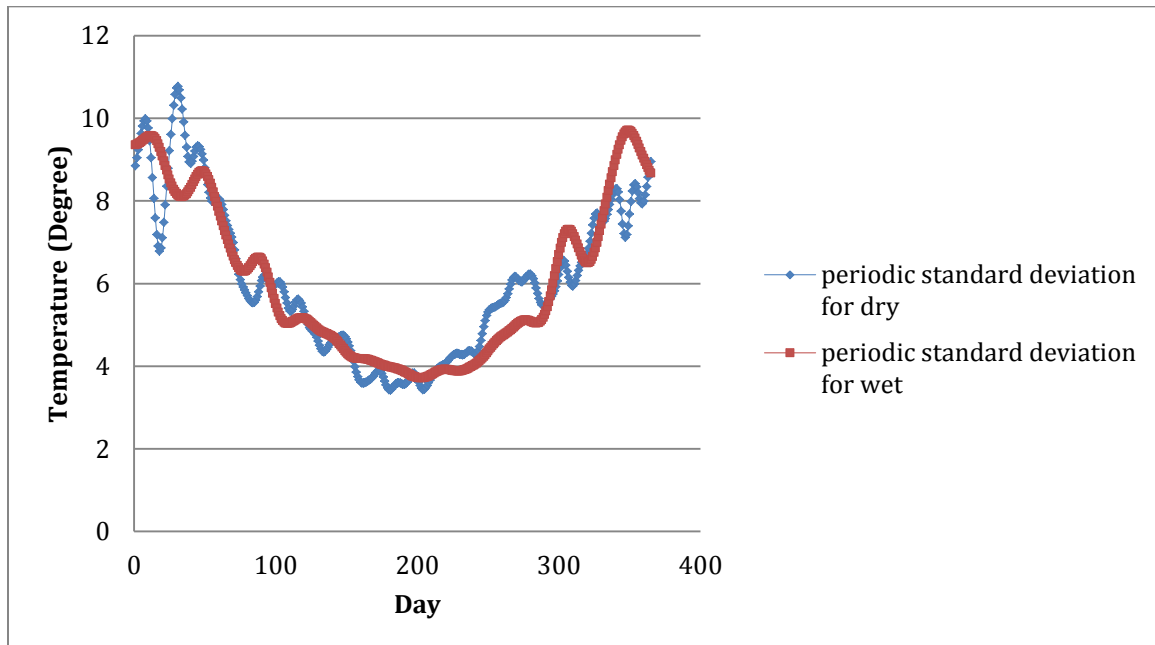




**Figure 9: Plot of Actual Standard Deviation and Smoothened Values**



**Figure 10: Plot of Maximum Temperature in 1990 and Its Periodic Mean for Dry and Wet Days**



**Figure 11: Plot of Periodic Standard Deviation for Wet and Dry Days in 1990**

The second step of applying weakly stationary generating process in predicting the temperatures is analyzing the residual elements to determine the time dependence within each series and independence among each series. In order to do this, serial correlation coefficients within each individual series from day to day, cross correlation coefficients between residual series elements on the same day, and cross correlation coefficients between series elements from day to day are required. A matrix defined by the calculated coefficients is used in the weakly stationary generating process to maintain the historical weather patterns. There are two matrices, A and B, generated to ensure that residual series maintain the serial and cross correlation characteristics of the historical series.

Matrices A and B can be determined from the following two equations:

$$A = M_1 M_2^{-1} \dots \dots \dots (3)$$

$$BB^T = M_0 - M_1 M_0^{-1} M_1^T \dots \dots \dots (4)$$

$M_0$  and  $M_1$  are  $(2 \times 2)$  lag 0 and lag 1 matrices of residual series, respectively, because two weather variables will be determined in use, as shown in the following equations:

$$M_0 = \begin{bmatrix} 1 & \rho_0(1,2) \\ \rho_0(2,1) & 1 \end{bmatrix} \dots \dots \dots (5)$$

$$M_1 = \begin{bmatrix} \rho_1(1) & \rho_1(1,2) \\ \rho_1(2,1) & \rho_1(2) \end{bmatrix} \dots \dots \dots (6)$$

$\rho_0(1, 2)$  and  $\rho_0(2, 1)$  are lag 0 cross correlation coefficients between variables 1 and 2. In the weather generation model, variable 1 and 2 represent maximum and minimum temperature.  $\rho_1(1)$  and  $\rho_1(2)$  are the lag 1 serial correlation coefficient for variable 1 and 2.  $\rho_1(1, 2)$  and  $\rho_1(2, 1)$  are the lag 1 cross correlation coefficient between variable 1 and 2.

In weakly stationary generating process, new residuals need to be determined by advancing the current residuals one day through a mapping procedure involving the correlation matrices and adding a random component. The equation below shows the way of calculating the new residuals during simulation:

$$x_d(i) = Ax_{d-1}(i) + B\varepsilon_d(i) \dots \dots \dots (7)$$

The variables  $x_d(i)$  and  $x_{d-1}(i)$  are  $(n \times 1)$  matrices of residual elements for variable  $i$  to  $n$ .  $\varepsilon_d(i)$  is a  $(n \times 1)$  matrix of independent random components sampled from a normal distribution with a mean of 1 and a variance of 1. The actual maximum and minimum temperatures are calculated by multiplying the current day's residuals by periodic standard deviations and then adding periodic means.

Detailed stochastic weather generation model and its simulation procedures based on the 20 years historical weather records in Edmonton area are shown as follows:

1. Sort out the daily precipitation amounts in the historical records. If precipitation amount is  $< 0.2\text{mm}$ , it is defined as dry day. Otherwise, it is defined as wet day.
2. At the beginning, generate uniform random number on  $[0, 1]$ .
3. If current day is the first day, compare random number with  $P(w)$ . If the random number is smaller or equal to  $P(w)$ , the first day is a wet day. Otherwise, the first day is dry.

If current day is not the first day, compare the random number with two transitional probabilities:  $P_{m,d}(w/w)$  and  $P_{m,d}(w/d)$ . If the previous day is wet and the random number is smaller than or equal to  $P_{m,d}(w/w)$ , current

day is wet, otherwise is dry. If the previous day is dry and the random number is smaller or equal to  $P_{m,d} (w/d)$ , current day is wet, otherwise is dry.

4. If the day is wet, the precipitation needs to be determined. Generating a uniform random number on  $[0, 1]$  and mapping to a probability distribution for the current month can determine the precipitation amount of the day. If the day is dry, the precipitation amount is considered 0.
5. Then sample two random numbers from a normal distribution with a mean of 0 and a variance of 1. These numbers are the random components used in the weakly stationary generating process as  $\varepsilon_d(i)$ .
6. Before determining the maximum and minimum temperature, residuals need to be determined first.

If current day is not the first day, then today's residuals can be generated directly by applying the weakly stationary generating process.

If current day is the first day, the initial previous residual needs to be generated. First, sample residuals from normal distributions with a mean of 0 and a variance of 1. Second, generate new set of residuals by applying the weakly stationary generating process. Third, place new set of residuals in previous day residuals and generate another new set of residuals. Fourth, repeat the third procedure 7 times. After repeating 7 times, use the

generated set of residuals as initial previous residuals, and generate the first day's residuals by applying the weakly stationary generating process.

7. Determine actual values of maximum and minimum temperatures for the current day by applying the residual equation depending on the precipitation status of the day.
8. Advance clock one day, and repeat the procedures from step 2 to step 8.

The following flowchart in Figure 12 shows the complete simulation process of the stochastic weather generation model.

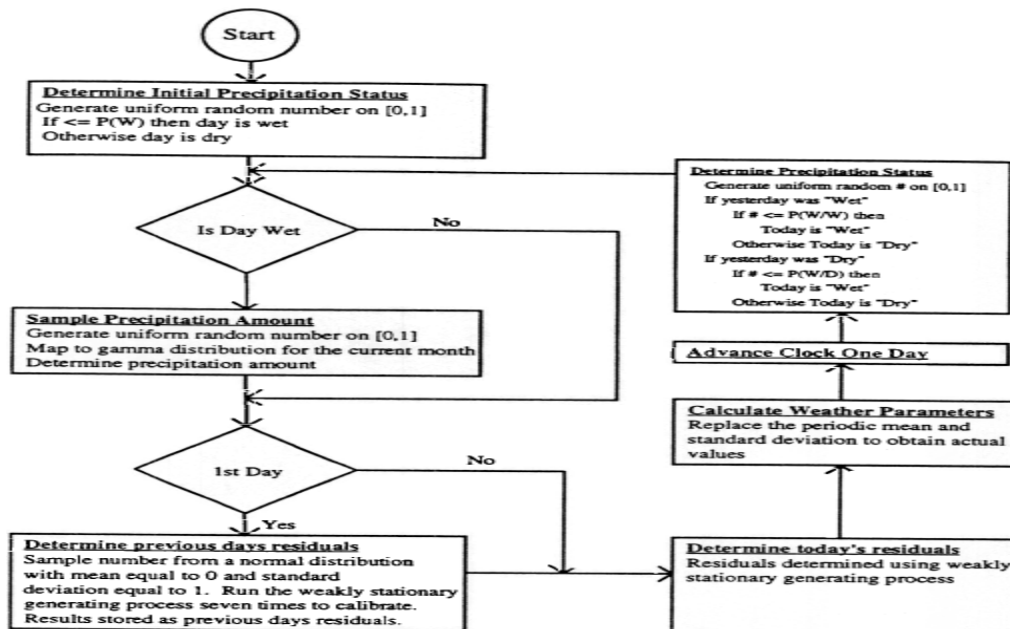


Figure 12: Stochastic Weather Generation Model (Wales 1994)

#### **4.2.2 Validation and Modification of Stochastic Weather Generation Model**

The stochastic weather generation model developed by Wales is a good tool for predicting the weather conditions in the simulation environment. In order to build the model into Symphony.NET for simulation, validation has been done. Some parts are modified for better predicting and fitting to Symphony.NET.

First, the original weather generation model recommended that gamma distribution fitted the precipitation for the month. However, by doing K-S tests of historical records, it is found that gamma distribution is not the best choice. Beta distribution and log normal distribution fit better than gamma distribution. Both the moment matching and maximum likelihood methods are used to do the K-S test. In addition, when generating the precipitation amounts on wet days, the model usually generates one or two small values, less than 0.2 mm in a month, by mapping the random number to the gamma distribution. In the definition, the precipitation amounts on wet days should be larger than or equals to 0.2 mm. Thus, it is proved that gamma distribution is not the perfect fit. While using the beta distribution or log normal distribution, no generated precipitations smaller than 0.2 mm happened. Figure 13 lists the modified distribution and transitional probabilities for each month.

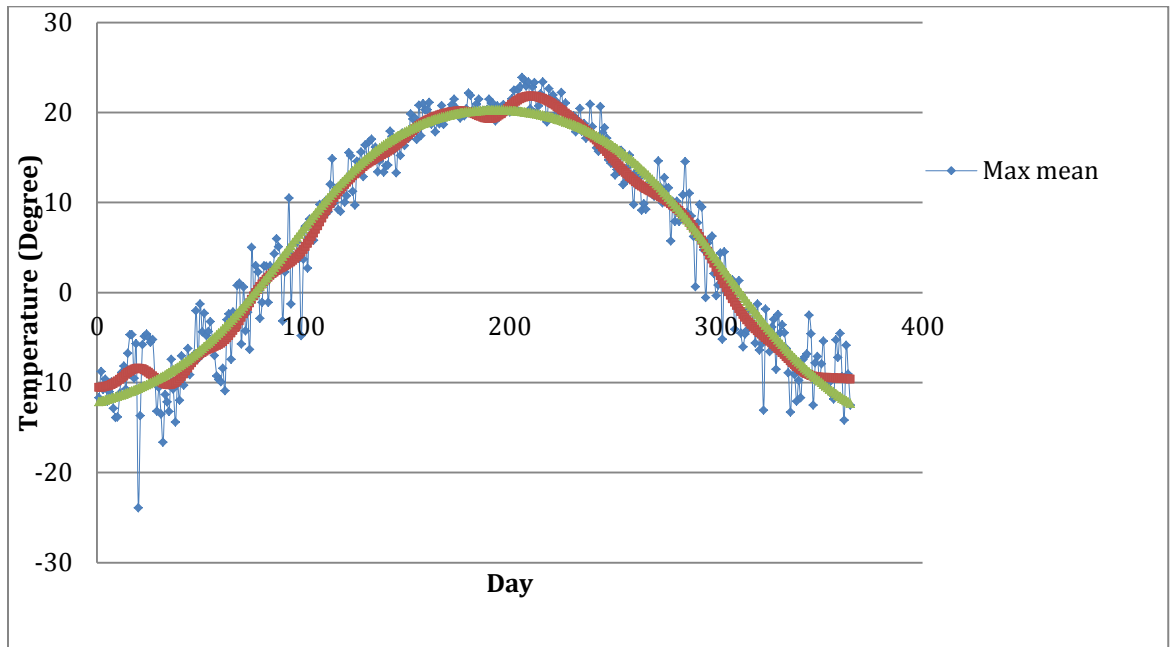
In addition, the general regression neural network (GRNN) is a memory-based network which can estimate the continuous variable. It can do the time series approximation, so that it is a good tool used to smooth the means and standard



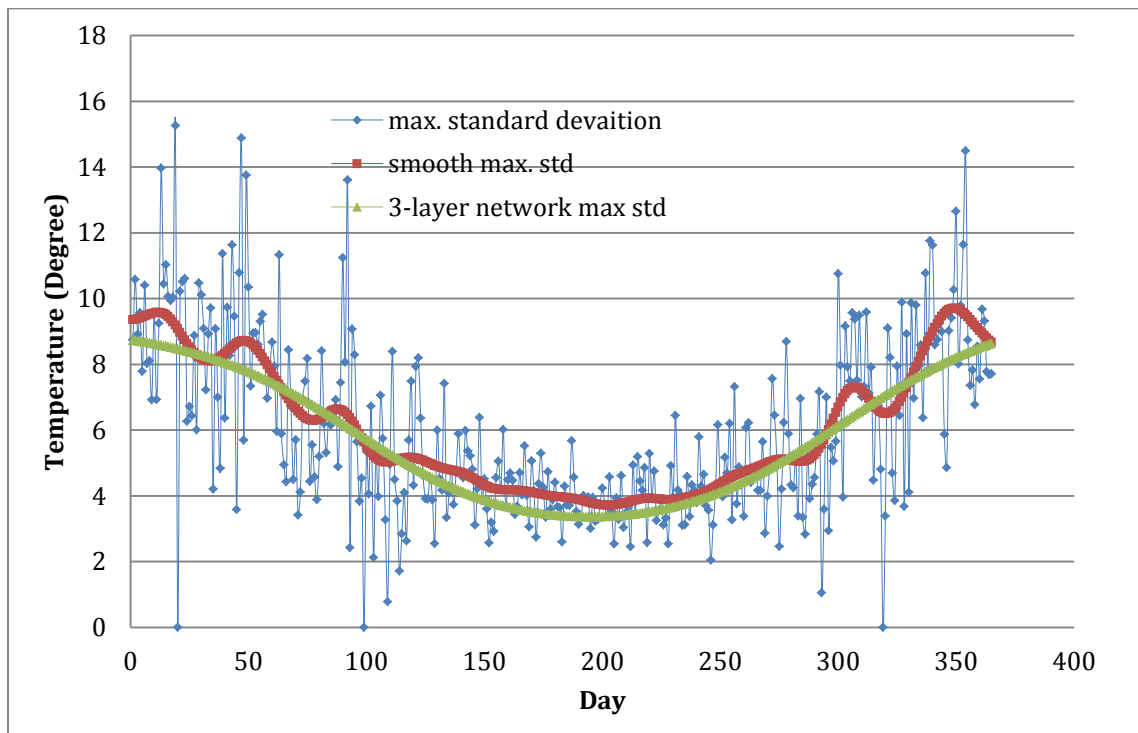
deviations of daily maximum and minimum temperature in the stochastic weather generation model. However, when building the stochastic weather generation model in Symphony.NET, the disadvantage of GRNN appears. According the theory in developing the GRNN, the hidden layer has one neuron for each case in the training data set. The number of neurons in hidden layer can be increased when increasing the training data, but the number of neurons cannot be reduced. There are 365 sets of data in which 80% will be used for training and the remaining 20% are used for testing, so there are 292 cases in the training data set. It means that the GRNN needs 292 neurons in the hidden layer which makes it difficult to be built in Symphony.NET, and the simulation speed will be slowed down. Therefore, a simple standard three-layer neural network is used to replace the general regression neural network to predict the periodic mean and standard deviation. Figures 14 and 15 are plots of actual means of maximum temperature for wet days comparing with periodic means generated by general regression neural network and standard three-layer neural network with 5 neurons in hidden layer. From Figures 14 and 15, it can be found that the curve made by standard three-layer neural network is not more perfectly fit than that made by general regression neural network. However, it is still good enough for fitting the historical data. Then the predicted values by standard 3-layer neural network can be fitted to fifth degree polynomial equations, which are easily built in Symphony.

Month	$P(w/d)$	$P(w/w)$	$P(w)$	Distribution	Parameters
January	0.24359	0.566667	0.353226	Log Normal	Location: 0.18527, Shape: 0.9859
February	0.227397	0.537143	0.325	Log Normal	Location: 0.15037, Shape: 0.815289
March	0.242925	0.403409	0.287097	Beta	$\alpha$ : 0.74477, $\beta$ : 24.291298 High: 46.23486, Low: 0.2359773
April	0.192308	0.391304	0.238333	Log Normal	Location: 0.27766, Shape: 0.943687
May	0.283117	0.506977	0.358065	Beta	$\alpha$ : 0.538074, $\beta$ : 2.83019 High: 12.6388, Low: 0.375713
June	0.372611	0.586466	0.465	Beta	$\alpha$ : 0.81569, $\beta$ : 6.1213565 High: 16.2202, Low: 0.2999
July	0.372372	0.520599	0.440323	Beta	$\alpha$ : 0.614556, $\beta$ : 2.021621 High: 8.91985, Low: 0.3875172
August	0.363636	0.483871	0.41129	Beta	$\alpha$ : 0.53227, $\beta$ : 3.84385 High: 12.24054, Low: 0.403758
September	0.253264	0.522843	0.34	Beta	$\alpha$ : 0.57546, $\beta$ : 2.513915 High: 10.0302615, Low: 0.305159
October	0.173729	0.375	0.214516	Log Normal	Location: 0.067437, Shape: 0.8361034
November	0.221675	0.465517	0.298333	Beta	$\alpha$ : 0.4446, $\beta$ : 3.3230186 High: 10.56452, Low: 0.2999
December	0.258486	0.529954	0.359677	Beta	$\alpha$ : 0.58028, $\beta$ : 17.90292 High: 42.33702, Low: 0.2577

**Figure 13: Modified Probability and Precipitation Distribution**

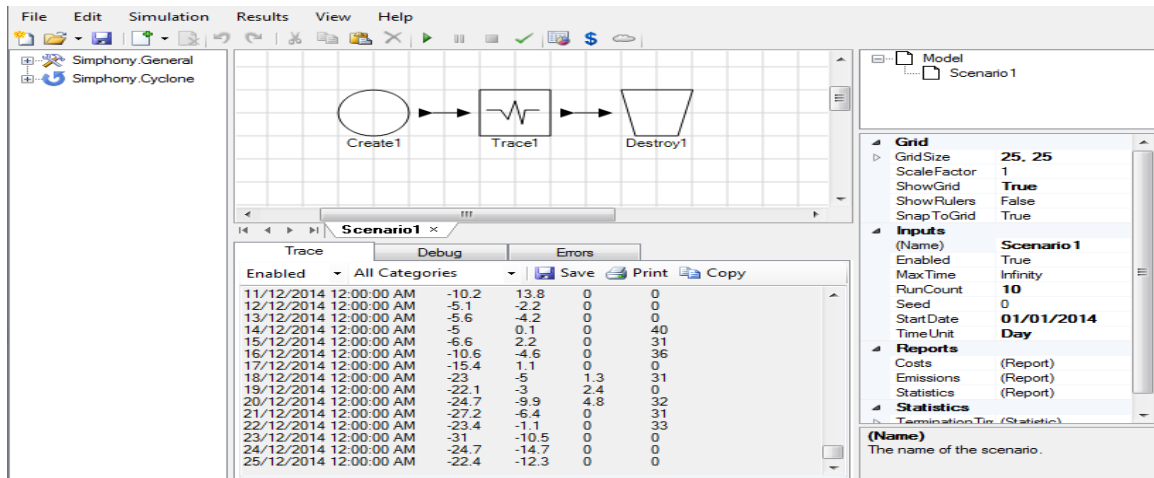


**Figure 14: Comparison between GRNN and 3-Layer Neural Network**



**Figure 15: Comparison between GRNN and 3-Layer Neural Network of Standard Deviation**

The stochastic weather generation model has been built in Symphony.NET. The stochastic weather generation model in Symphony includes the fourth parameter, maximum gust speed, which is generated by the same method as maximum and minimum temperatures. In order to validate the model in Symphony, a model is made to generate 10 years daily weather conditions: precipitation, maximum temperature, minimum temperature, and maximum gust. The model is shown in Figure 16 below.



**Figure 16: Weather Generation Test Model**

The wet probability,  $P(w)$  for the predicted weather conditions is listed in Table 1 below. Compared to historical data, the  $P(w)$  values for the predicted weather conditions do not exceed the historical values, as shown in Table 1.

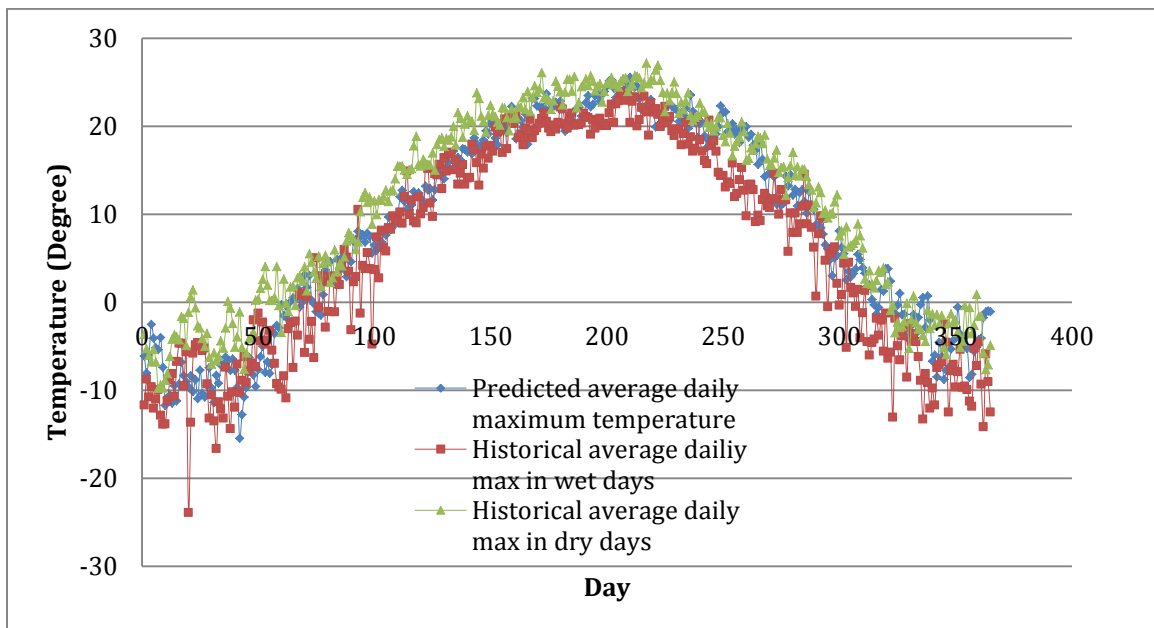
Month	Historical $P(w)$	Predicted $P(w)$
January	0.358766	0.3387
February	0.28877	0.214
March	0.303426	0.124
April	0.286957	0.24
May	0.368151	0.2

June	0.480565	0.173
July	0.496599	0.2354
August	0.383701	0.174
September	0.316901	0.117
October	0.28109	0.103
November	0.285211	0.143
December	0.28988	0.1516

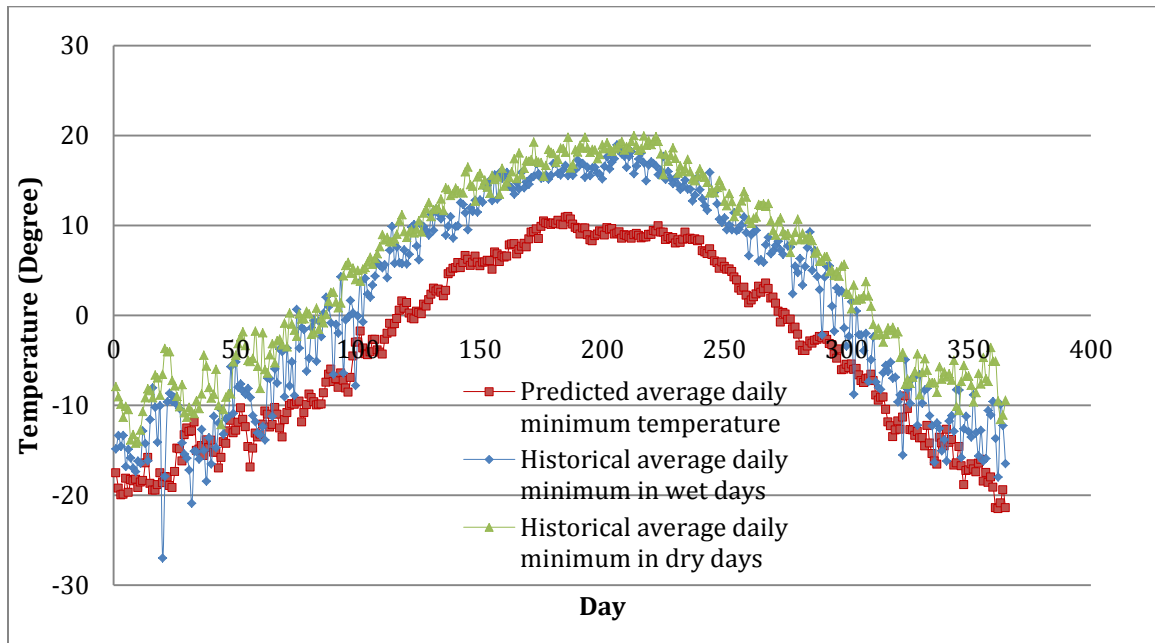
**Table 1: Monthly Wet Probability—Historical vs. Predicted**

By comparing the average daily minimum temperature and maximum temperature of predicted weather conditions to historical values, as shown in Figure 17 and Figure 18, the predicted maximum temperature perfectly fit the historical values. The values of predicted minimum temperature are a little bit lower than the historical values, but the shape of the predicted curve is similar to the historical curves. The possible reason for the predicted minimum temperature to be lower than the historical values is that the fifth polynomial equations for periodic mean and standard deviations of minimum temperature do not perfectly fit the historical trend. The differences between predicted minimum temperatures and actual

values in fall and winter are less than 5 degrees which is not a substantial defect, while the differences for minimum temperatures in spring and summer are about 10 degrees, which is substantial. Since the temperatures between 0 degree and 30 degrees will have few impacts on the equipment performance, the big differences in winter and summer can be accepted as well. Therefore, the stochastic weather generation model is validated and can be used in the further analysis.



**Figure 17: Mean Values of Predicted Maximum Temperature vs. Historical Values**



**Figure 18: Mean Values of Predicted Minimum Temperature vs. Historical Values**

#### 4.2.3 Weather Effects on Production and Speed

Since excavator/shovel and trucks are the major equipment used in earth moving operations, the production rate of the excavator and the speed of the trucks are two factors that will determine the whole project duration and the costs. Different types of excavators and trucks will have different performance. Even for the same type of equipment, production rate and speed may be different. Because there are many factors that could affect the work performance of the excavator and trucks, the production and speed cannot stay constant. At the bidding stage, construction companies will choose a constant value based on engineers' experiences and the



companies' bidding strategy when estimating. Therefore, the bidding price could be conservative or risky according to the selected production and speed. In previous research, probability distributions have been used to represent the production and speed and handle the Monte Carlo simulation to provide more accurate estimation in consideration of all potential uncertainties that may affect equipment performance. Artificial neural network is a good tool that can predict the production and speed based on related factors. By collecting and training numerous historical data sets, the developed neural network can have the same functions as probability distribution. In addition, the value generated by neural network will be closer to real situations. The developed neural networks will also be used to analyze the impacts of inclement weather conditions on equipment performance and whole project by doing the sensitivity analysis.

#### ***4.2.3.1 Development of Neural Network***

To develop the artificial neural network for predicting the excavator production and truck speed, the first step is to identify all the inputs that are related to the outputs. Tables 2 and 3 list the possible inputs and outputs for the neural networks.

Excavator Production	
Inputs	Outputs
Excavator Types  Excavator ages (years)  Soil Properties (types, density, etc.)  Stability of Footing (stiff, medium, soft)  Operator Skills (experiences: years)  Temperature (maximum, minimum)  Precipitations (millimeters)  Digging Depth (meters)  Loading Positions (swing angle)  Loading Height (meters)  ...etc.	Excavator Production (BCM/hr.)

**Table 2: Inputs and Outputs of Neural Network for Excavator Production**

Truck Speed	
Inputs	Outputs
Operator Skills (experiences: years)	Truck Loaded Speed (km/hr.)
Temperature (maximum, minimum)	Truck Empty Speed (km/hr.)
Loads (Tones)	
Truck Types	
Wheel Types	
Truck Ages (years)	
Haul Road Conditions (grade)	
Haul Road Grade (%)	
Precipitations (millimeters)	
...etc.	

**Table 3: Inputs and Outputs of Neural Network for Truck Speed**

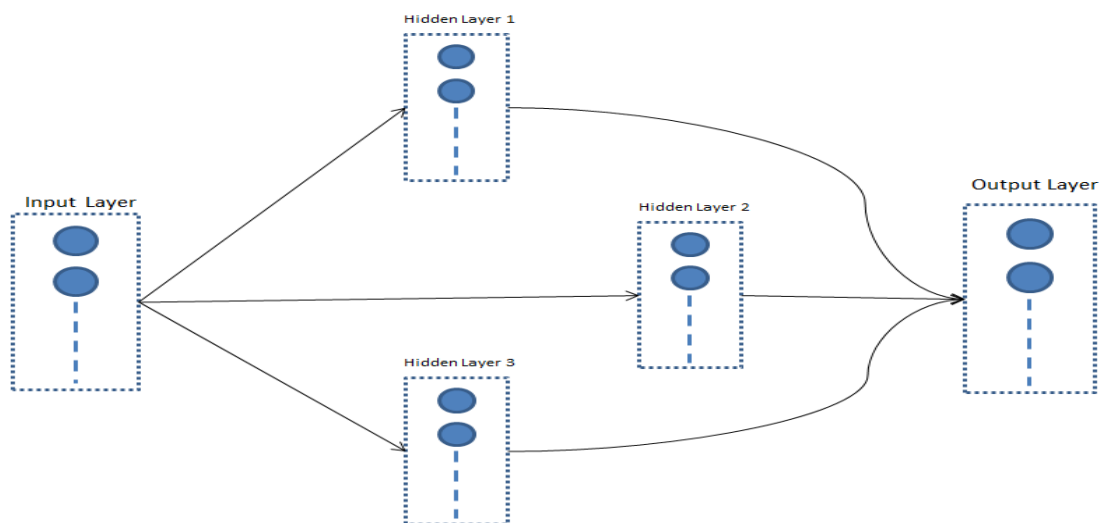
The excavator is usually used for digging and loading soil in earth moving operations. Different soil types will have different stiffness, which will affect the excavator's production. The footing of the excavator will also have effects on

productivity. The operator's skills and the loading positions have effects on production as well. Weather is another important factor in an excavator's operation. If the temperature is too cold, it will increase the stiffness of soil and the performance of the equipment will decline. Trucks are used for hauling and dumping soil. The trucks' speed will be affected by the rim pull force of the truck, the haul road grade, rolling resistance and the gross weight of the trucks. The rolling resistance is affected by weather, tire condition, and haul road condition.

The data used in this thesis was provided by a large construction company which is expert in earth moving projects. The data is a Caterpillar VIMS database recorded in 2011 and 2012. According to the data collected in VIMS, only truck type, payload, loading time, average loaded speed and average empty speed, and excavator type can be used in developing the neural network. Since the data was recorded in northern Alberta, the daily maximum and minimum temperature and precipitation can be checked from the Environment Canada website. There are no other data, such as haul road conditions, haul road types, equipment age, and operator's information recorded, because the data recorded is not specific for the research purpose in this thesis. However, it still works for developing neural networks for predicting the production and speed.

In 1998, Hajjar and Mather developed a neural network for predicting the excavator's production. They used the simple three-layer radial basis function (RBF) neural network. There are 13 neurons in the input layer, and 4 neurons in a

hidden layer. Since the data collected in the VIMS is not enough, the simple three-layer RBF neural network is not very fit. By trying different types of neural networks with NeuroShell, the multiple hidden slabs neural network was used, as shown in Figure 19. It is a back propagation neural network developed and validated by Wards Systems Group (1991). The advantage of this neural network is to provide three different ways of viewing data and combining it together to get a better prediction. The input layer has 3 neurons representing 3 inputs. Each neuron in the input layer will connect to every neuron in the hidden layers with a certain weight. There are three different hidden layers. Each type of hidden layer is connected with the input and output layer. There are no interactions between different types of hidden layers. Each hidden layer has 15 neurons and its own activation function. The activation function in hidden layer 1 is Gaussian function. The activation function in hidden layer 2 is hyperbolic tangent function. The activation function in hidden layer 3 is a composite Gaussian function. The inputs in the neural network for excavator production are soil type, maximum temperature, and minimum temperature. The inputs for loaded speed are payload, maximum temperature, minimum temperature, and precipitation. The inputs for empty speed are the same as those for loaded speed, except the payload. 20% of the data are randomly picked for testing, and the rest of data are used for training. The artificial neural network was used for predicting the production of Hitachi EX1200, and the speed of Caterpillar off-road truck 785D.



**Figure 19: Neural Network for Predicting Production and Speed**

#### ***4.2.3.2 Neural Network Prediction and Validation***

By analyzing the historical data using @RISK software, the production of EX1200, empty speed of truck 785D, and loaded speed of truck 785D can be fitted to a specific probability distribution, as shown in Figures 20, 21, and 22, respectively. The fitted results by @RISK are listed in Table 4, as follows.

Name	Fitted Distribution	Mean	Standard Deviation	Most Likelihood Value
EX1200 Production (BCM/hr.)	Logistic	895.1	288.50	894.16
Truck 785D Loaded Speeds (km/hr.)	ExtValueMin	34.228	5.367	34.12
Truck 785D Empty Speeds (km/hr.)	ExtValueMin	34.812	6.918	35.230

**Table 4: Fitted Results by @Risk**

The production of EX1200 can be fitted to the logistic distribution shown in Figure 20. The mean value is 895.1 BCM/hr, the standard deviation is 288.50, and the most likelihood value is 894.16 BCM/hr. The empty speed for truck 785D is fitted to the ExtValueMin distribution shown in Figure 21. The mean value and the standard deviation of empty speed are 34.812 km/hr and 6.918, respectively. The most likelihood value of empty speed is 35.230 km/hr. The shape of loaded

speed of 785D is almost the same as its empty speed. By testing the K-S values, the loaded speed can be fitted to both logistic and ExtValueMin. For convenience, the loaded speed is fitted to ExtValueMin distribution. Its mean value and standard deviation are 34.228 km/hr and 5.367, respectively. The most likelihood value is 34.12 km/hr which is a little bit smaller than empty speed.

The neural networks for production, empty speed, and loaded speed have been trained and tested by NeuroShell. In order to validate the neural networks, the predicted values are generated and plotted in Figures 23, 24, and 25 for comparison. From these plots, it can be found that the curves of predicted production and speed are close to flat, which is not similar to the curves of historical data. The compared results are listed in Table 5. The minimum absolute error of predicted EX1200 production is 0.321, and the maximum absolute error is 1340.242. The mean absolute error is 189.338. For empty truck speed, the minimum absolute error of predicted value is 0, while the maximum absolute error is 40.496. The mean absolute error is 4.736. From the plot in Figure 25, the loaded speed is more similar to the actual curve than the empty speed and excavator production, so that the errors of predicted loaded speed are smaller. The minimum absolute error is 0.001; the maximum absolute error is 35.585; the mean absolute error is 3.407.



Name	Minimum Absolute Error	Maximum Absolute Error	Mean Absolute Error
EX1200	0.321	1340.242	189.338
Empty Speed	0	40.496	4.736
Loaded Speed	0.001	35.585	3.407

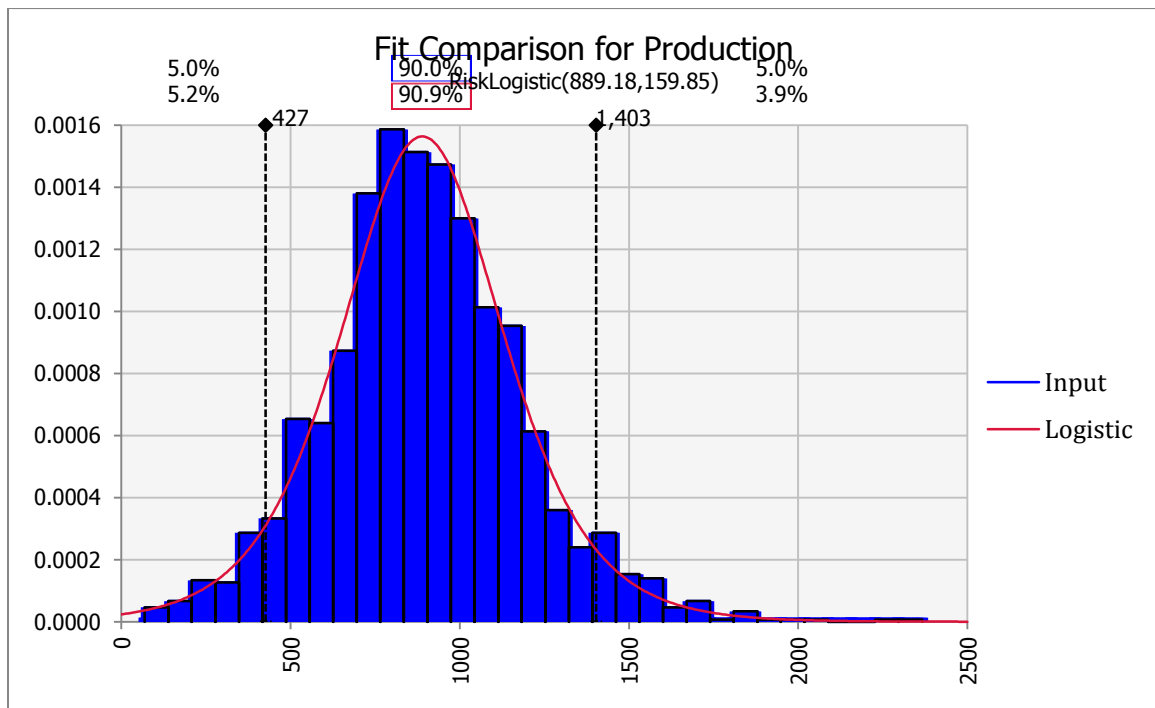
**Table 5: Errors between Actual Value and Predicted Value**

From these plots and statistics, it is shown that the neural network can be used to generate the production and speed, but the predicted values are not totally fitted to the historical patterns. The possible reasons for these errors are listed as follows:

1. Lack of historical data for the other important factors as inputs in developing the artificial neural network. The weather conditions and payload are not the only factors that affect excavator production and truck speed, so that the predicted values cannot fully fit to the characteristics of actual value. Just as the plots shown in Figures 26, 27, and 28, even under the same weather conditions, the loaded speed could be different. For example, the truck driver's driving habits could affect the speed. Since the gross weight could only affect the highest speed, the driving type will have impacts on the speed. That's one of the reasons that sometimes the

loaded speed will be a little bit higher than the empty speed in both historical records and predicted values

2. Lack of sufficient data for training the weather conditions. The historical data sets were only recorded in December, January, February, and March. The total working days recorded spanned greater than those months. Therefore, the data cannot totally fulfill the training need. Considering the lack of other important factors, the training results cannot clearly reflect the weather effects on the production and speed.



**Figure 20: Excavator EX1200 Production Distributions**

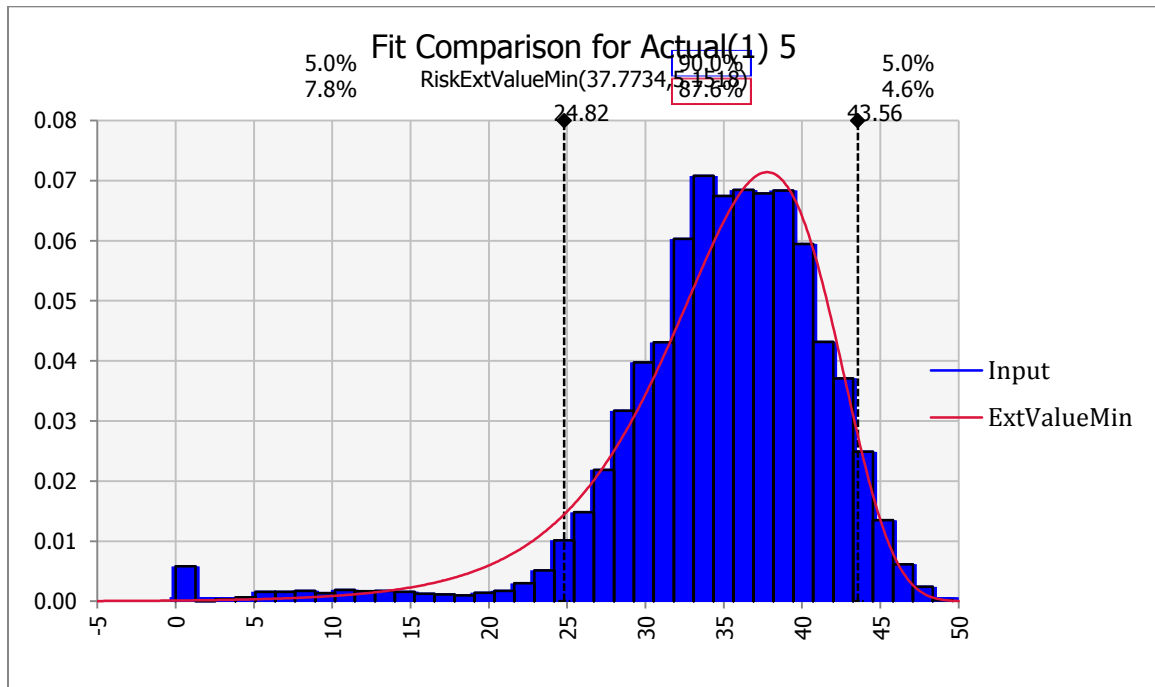


Figure 21: Truck 785D Empty Speed Distributions

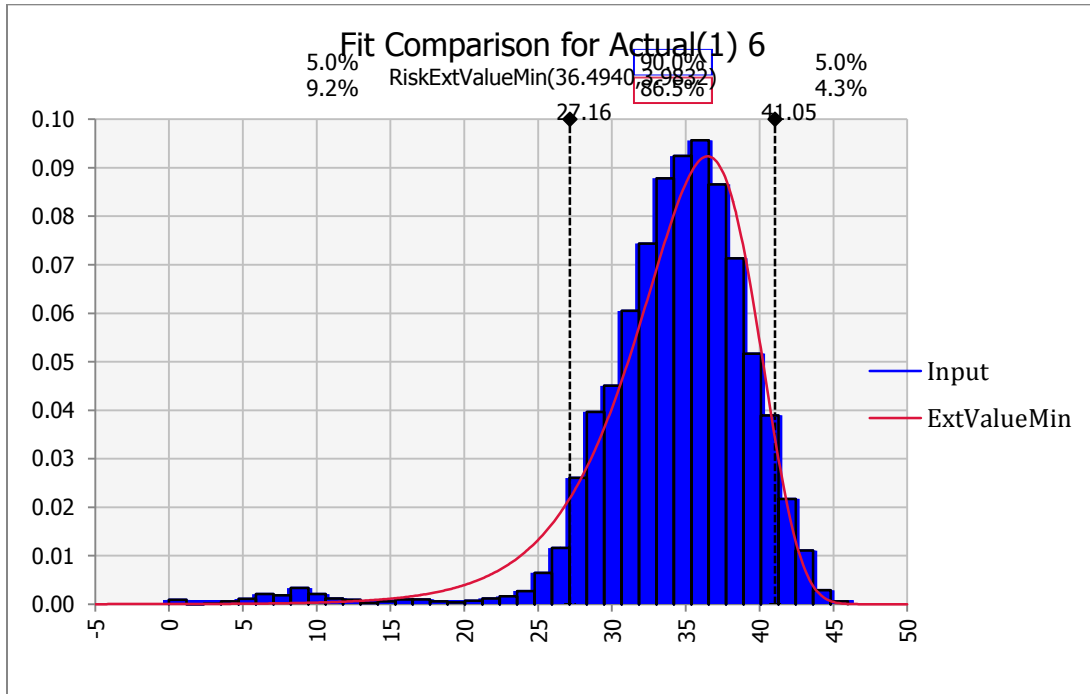


Figure 22: Truck 785D Loaded Speed Distributions

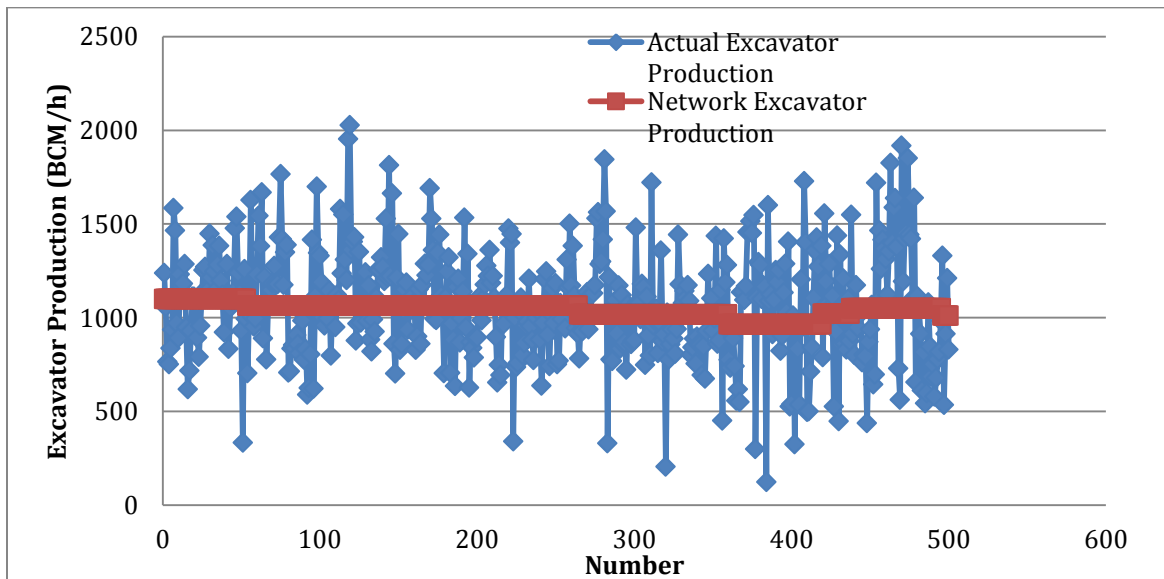
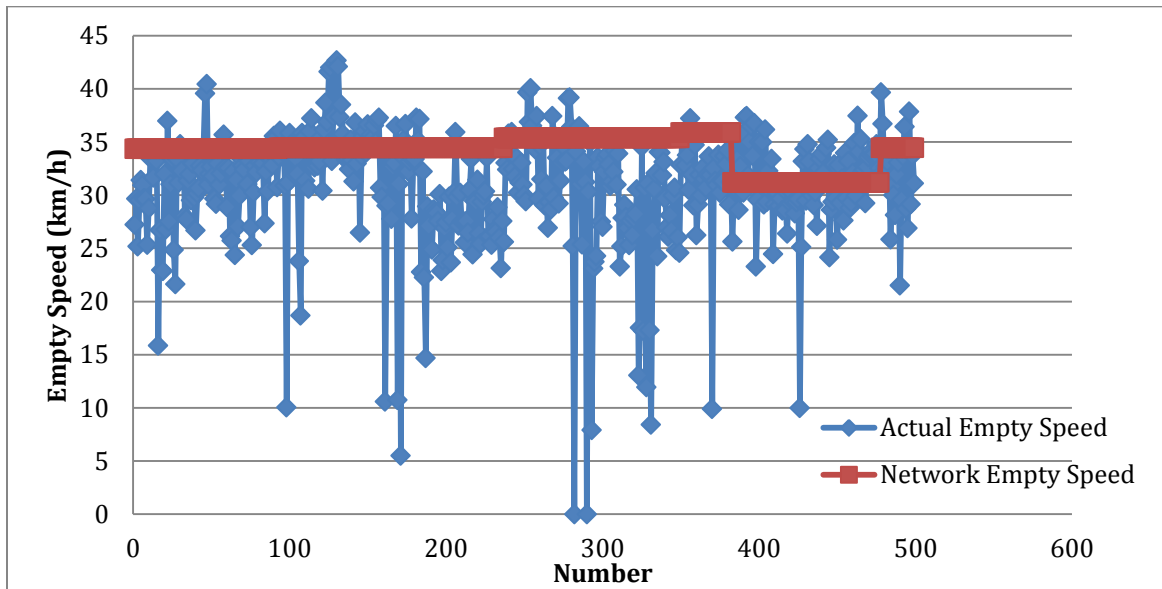
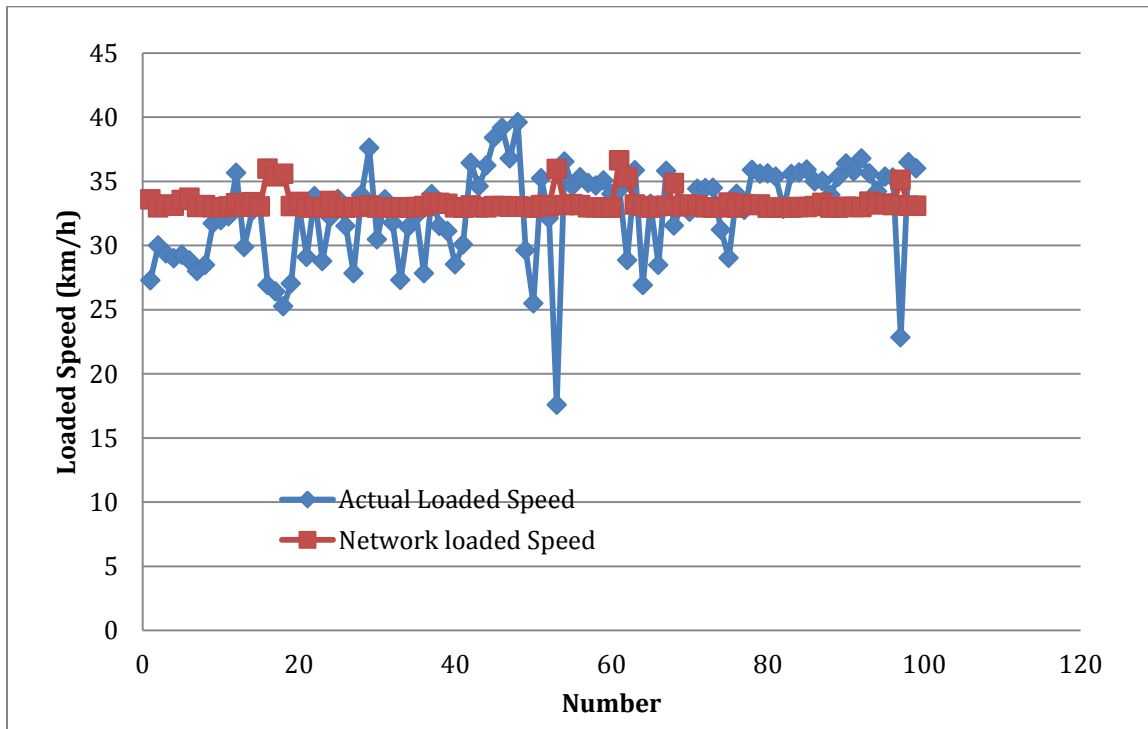


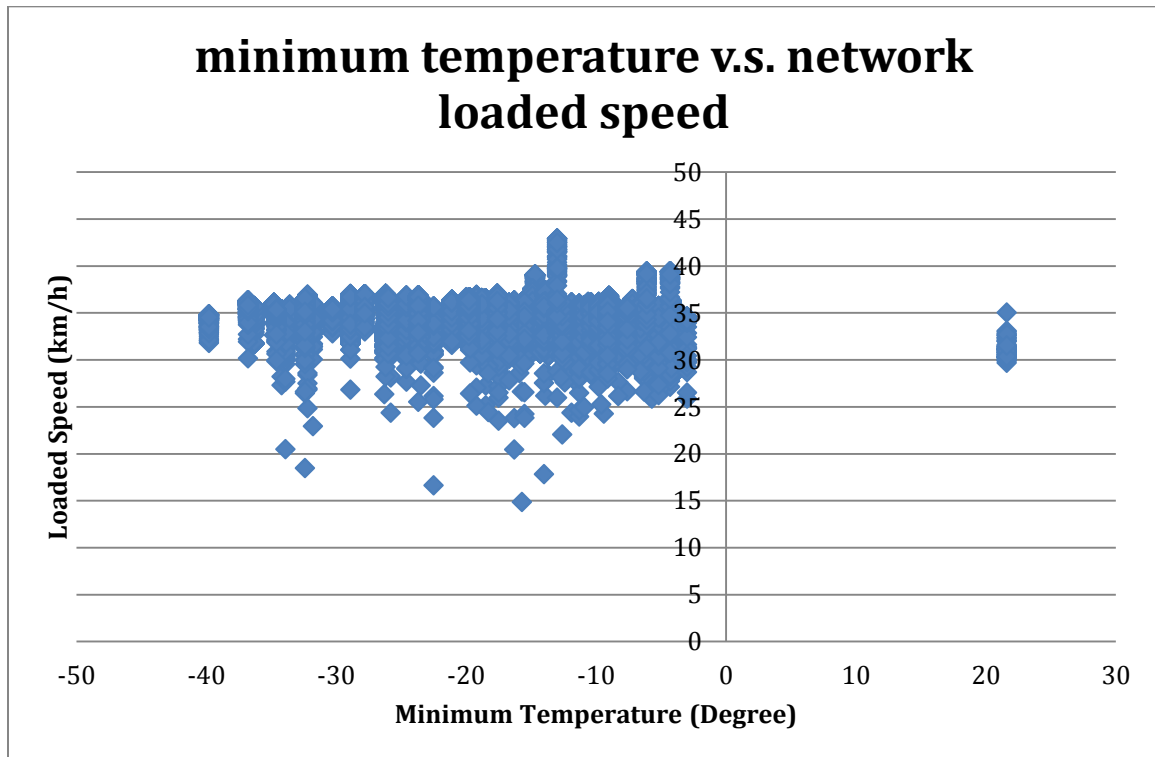
Figure 23: Plot of Actual Production vs. Network Prediction Value



**Figure 24: Plot of Actual Empty Speed vs. Network Prediction Value**



**Figure 25: Plot of Actual Loaded Speed vs. Network Prediction Value**



**Figure 26: Plot of Minimum Temperature vs. Network Loaded Speed**

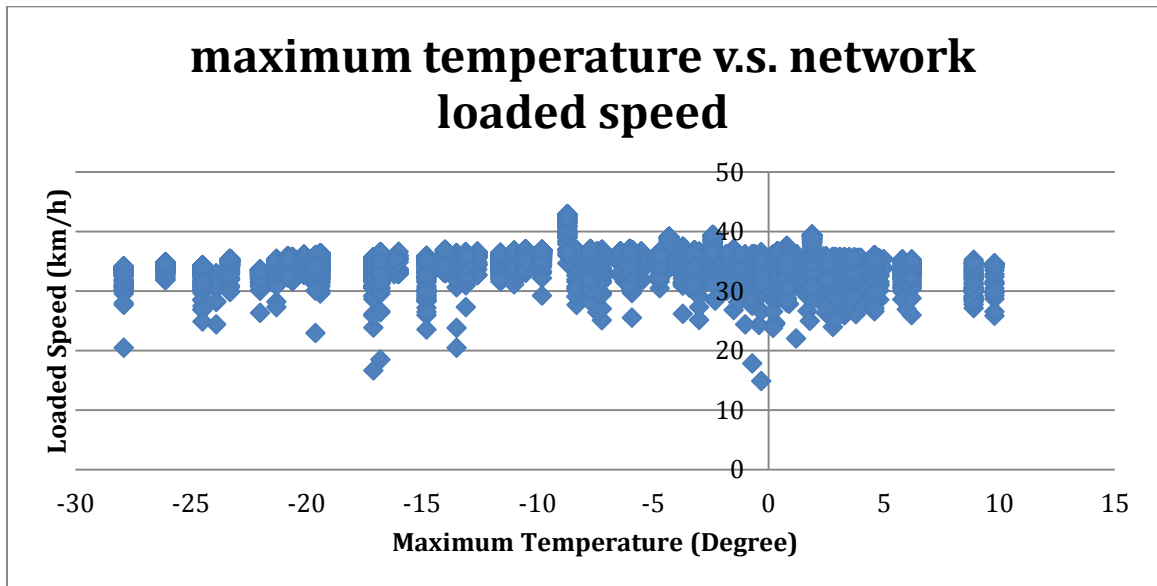


Figure 27: Plot of Maximum Temperature vs. Network Loaded Speed

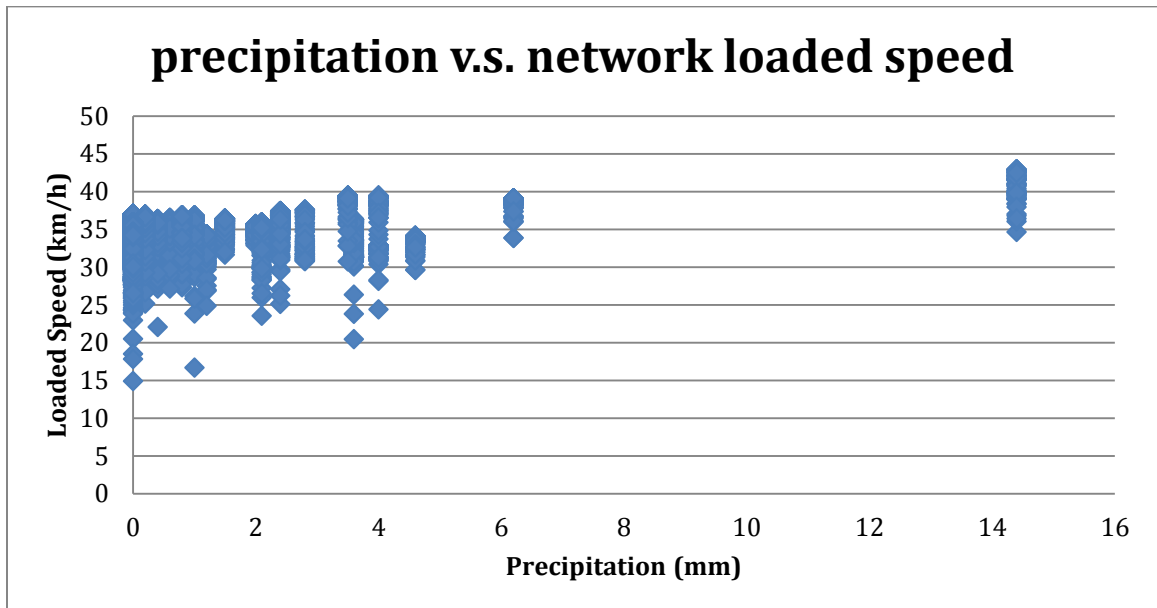


Figure 28: Plot of Precipitation vs. Network Loaded Speed

Weather conditions are only one of the factors affecting earth moving operations. Factors' combined effects cause the variety of production and speed. If the factors are not properly considered in artificial neural network development, the trained results cannot precisely represent the historical patterns.

Although the neural networks developed for predicting the EX1200 production and the truck 785D speed were not very successful, it still shows the advantages of artificial neural network in learning the complex relationship between inputs and outputs. In 2001, Lu did research on sensitivity analysis of back propagation neural networks in spool fabrication productivity studies. The back propagation neural network was proven to be a good tool for prediction. Therefore, if sufficient required data are collected, further research on the weather effects in earth moving operations can be completed. The effects of inclement weather conditions on the equipment performance can be analyzed by doing the sensitivity analysis.

#### **4.3 Tire Early Failure**

Trucks are one of the most important equipment types used in earth moving operations. Generally, there are two types of trucks: on-road trucks, and off-road trucks. Regardless of the type of truck, most of them are wheel-mount. Therefore, tire usage has potential effects on the hauling efficiency and costs.



Generally, tires will affect the hauling performance in two aspects. First, the performance of tires will affect the rolling resistance of the trucks, which will determine the travel speed of hauling. From the truck performance charts in the Caterpillar Performance Handbook (1998), as shown in Figure 6 above, it can be found that truck load, total resistance, and rim pull force are three main factors that determine the hauling speed of trucks. Truck load and total resistance will determine what rim pull force is needed so that companies can select the truck types based on the required rim pull force. Thus, the rim pull force will not cause any uncertainties during the earth moving operations except one situation, which is the mechanical failure of trucks. In addition, the truck loads will not vary much when loading the same type of soil. Therefore, the only factor that will affect the hauling performance is the total resistance. The total resistance is the summation of grade resistance and rolling resistance. The grade resistance is mainly determined by the conditions of the hauling route at the site, while the rolling resistance is determined by both the tires and the haul route conditions. The coefficient of friction between the tires and haul road can be affected by the haul road surface condition, tires' surface textile, and tire penetration. In use, the surface of the tires will be worn, which will affect the coefficient of friction between tires and the haul road, so that the rolling resistance will be not be a constant value. Since the effects of the tires on the haul road are continuously changing, it is difficult to simulate the effects of these kinds of changes.

Another aspect in which tires can affect hauling performance is the early failure of tires. It will directly increase the operational costs of trucks and interrupt the hauling process, which will extend the expected total project duration. Truck tires used in earth moving operations, especially large projects such as surface mining, are very expensive. For a large 6-tire off-road truck used in mining, each tire will cost \$40,000. What's more, the demand of these kinds of tires in the market is high because of the growth of the field of mining, energy, and related industrial construction areas. This means that the tires should be ordered earlier in case of the delay caused by the lack of tires. According to the investigation by Ekyalimpa (2012), the average life span of a tire is 5000 hours while working 4800 hours annually. Therefore, the annual tire costs for those earth moving companies who own large fleets of trucks will be over 1 million dollars without considering those unanticipated early tire failures. For some large earth moving projects like surface mining, which may span several years, tires cost will be an important consideration in the project cost.

In order to increase the efficiency of tire usage, companies that operate large fleets of trucks have a traditional method. For example, for a 2-axle, 6-wheel off-road truck used in mining, the traditional practice is to first assign the truck a new set of tires. When the new tires reach their half-life span, the two front tires with half-life are stored, and two new tires are installed. After another half-life, the 4 rear tires are totally worn out. At this time, two new tires will replace the half-life front tires, the replaced two front tires together with two stored front tires are

installed on the 4 rear wheels. Now two front tires are new, and four rear tires are half-life. After working half life span, the four rear tires are worn out, and the two front tires are half-life. Then, a new set of tires will replace the entire 6 front and rear tires. Those two half-life front tires are stored. Now the trucks have a new set of tires. The process will be repeated again until the end of the project. This traditional practice works under the ideal situation assuming no early failures occurred. All of the tires fulfilling the requirements are optimally utilized. While rotating the tires as described above, two sides of the trucks must be balanced all the time to ensure safety and efficiency of operations. This industrial practice can efficiently improve the cash flow in the project by reducing loans at a specific time point. Companies don't need to purchase a lot of new sets of tires at the same time which could be a large amount of money. However, the early failure of tires will interrupt the procurement and financial plans of companies during the projects, which is more serious than just increasing the total project cost.

In real situations, early failure of tires is common. Many uncertainties can cause early failures. In order to increase the accuracy of estimation, the risks of tire early failure should be considered at the bidding stage. A general simulation process for modeling the early failures of tires is proposed as follows:

1. Using historical data, the probability of early failure can be calculated by the following equation:

$$P(E) = \frac{n_e}{n_t}$$

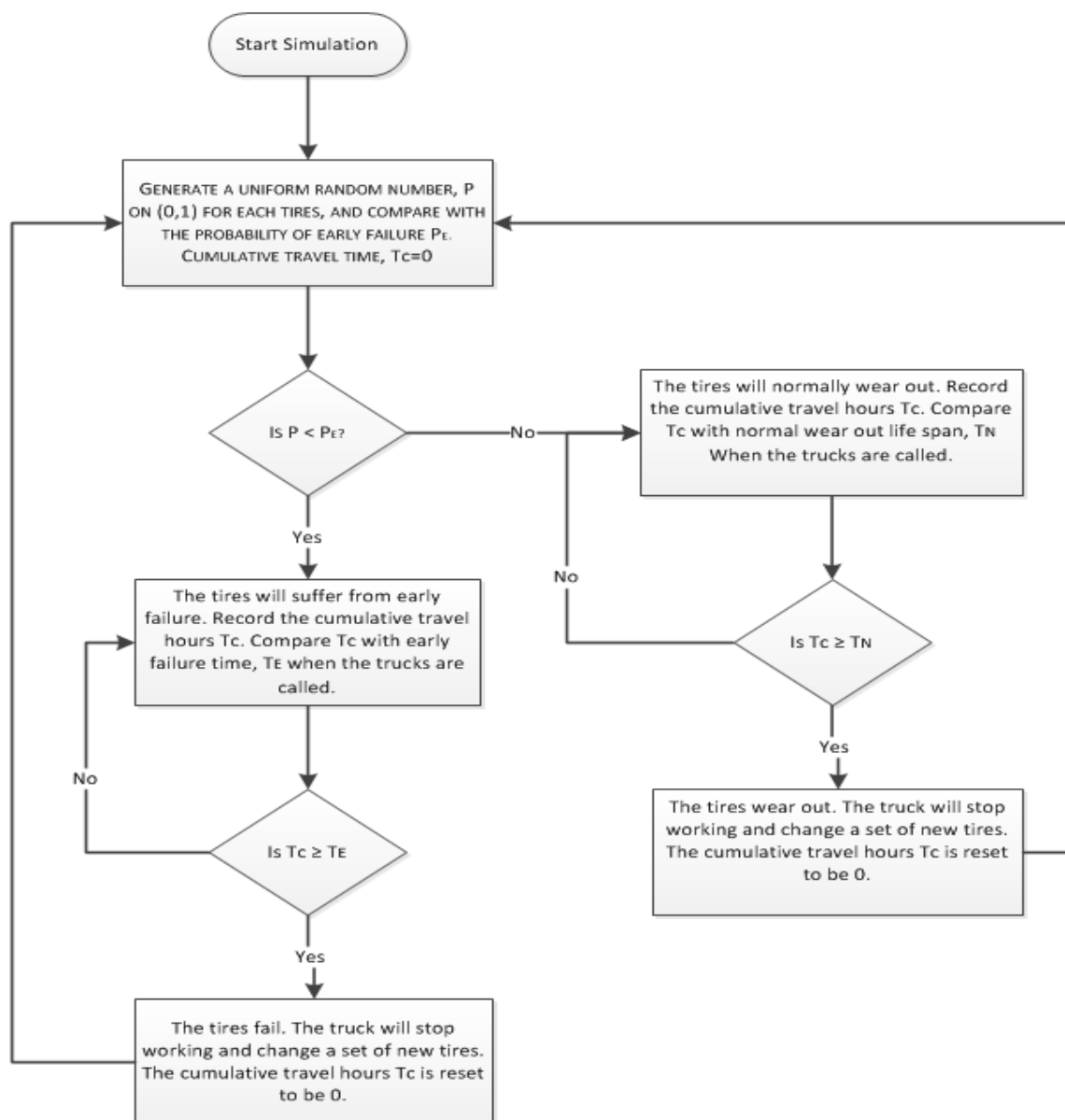
$P(E)$  is the probability of early failure,  $n_e$  is the number of tires that suffered early failure, and  $n_t$  is the total number of tires used.

2. The working hours for tires with early failure and normally worn out tires should be generated. By collecting the working hours of each early failure tire, a distribution can be fitted to the data set. The same process will be done to generate a distribution for the life span of normally worn out tires. The work hours for early failure tires should be shorter than the life span of normally worn out tires.
3. At the start of simulation, the total number of tires should be calculated for the selected truck fleet. The cumulative working hours for each tire is set to 0. Each tire will pass the early failure test by generating a random number from a uniform distribution between 0 and 1 for each tire. If the generated number is smaller or equal to  $P(E)$ , this tire will suffer from early failure, and its cumulative working hours during the simulation will be compared to the sampled early failure duration when the truck arrived at the source site or dumping site. Otherwise, the tire will normally wear out. If the tires reach the end of their life span, no matter if they suffered early failure or wore out normally, the truck will stop working and start

changing the tires. When the new tires set up, the cumulative working hours for each new tire will be reset as 0.

4. When finishing the simulation, the total number of early failure tires and total number of worn out tires are recorded. The tire cost will be calculated.

Figure 29 below is a flowchart showing the simulation process.



**Figure 29: Flowchart of Tire Usage Simulation**

#### 4.3.1 Model Testing and Validation

In order to test the simulation process of tire usage and find out the impacts of tire early failure on the projects, a large earth moving project is used to do analysis.

Simphony general template will be used to build the simulation model for this project including the process of tire usage. Since the tire usage data is confidential in earth moving companies, the data related to the tire usage in the models are hypothetical.

#### ***4.3.1.1 Project Description***

This earth moving project is for surface mining in northern Alberta. The total amount of earth to be excavated and dumped is 6,503,432 BCM. The average hauling distance is 5.675 km. One shovel and six trucks are used in the project. The shovel is Hitachi EX-3500. The capacity of the trucks is 100 BCM. The truck dumping time is 6 minutes. The production of EX3500 and the speed of the trucks are listed in Table 6 below.

Equipment	Production/Speed	Quantity
Shovel	Beta (4,3,1200,1700)	1
Trucks	Beta(4,3,30,40)(loaded), Beta(4,3,35,45)(empty)	6

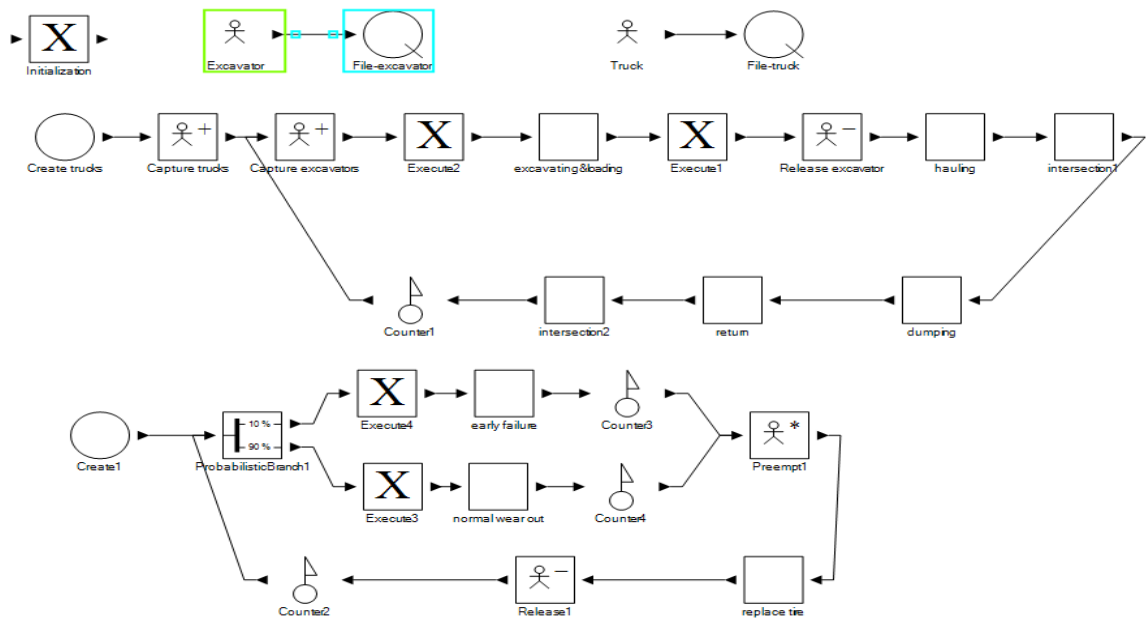
**Table 6: Equipment Properties**

There are 6 trucks used in the project, so the tire number is 36. Each tire has 10% of chance of suffering from early failure. The early failure time is a triangular distribution, triangular (2000, 4000, 3000) hours. The normal wear-out time for a

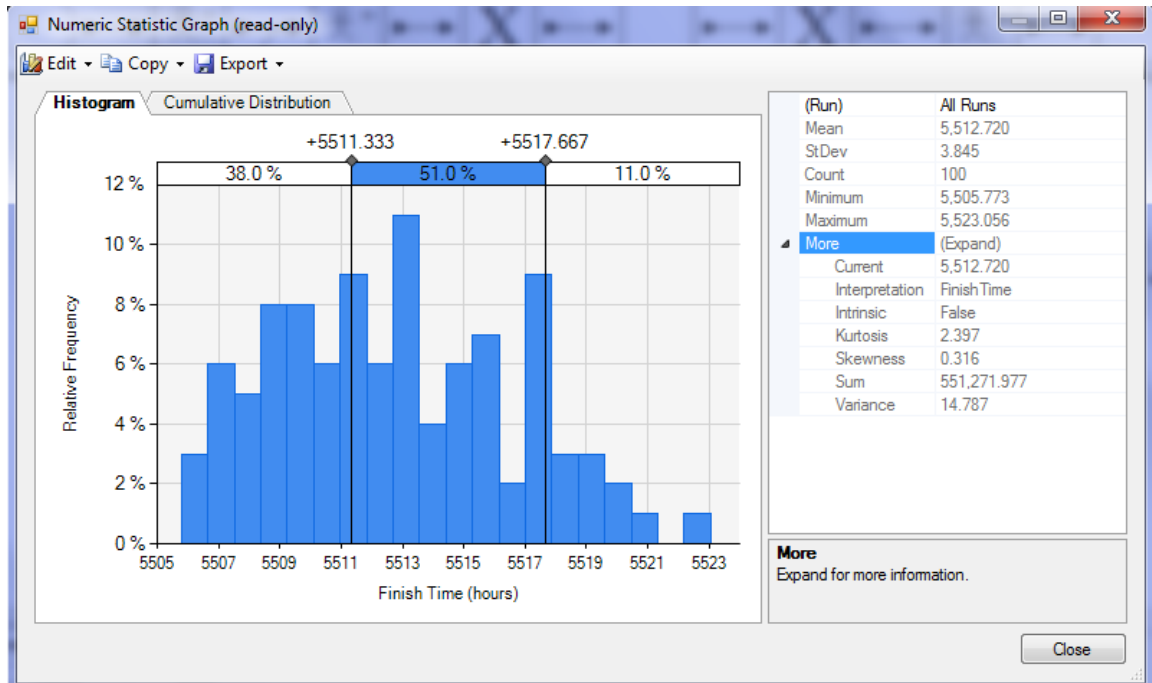
tire is also a triangular distribution, triangular (4500, 6000, 5000) hours. The time for a truck to change the tire is uniformly distributed from 1 hour to 3 hours.

Since the project has the most typical earth moving process, the general Symphony model is simple, as shown in Figure 30. There are 3 scenarios built for evaluating the tire usage and early failure. Scenario1 considers the tire usage and early failure. Scenario 2 does not consider any tire usage. Scenario 3 considers the tire usage, but does not consider the tire early failures. The results of these three scenarios are compared with each other to find the effects of early failure. After running these three scenarios 100 times, the simulation results are shown in Figures 31, 32, and Figure 33.

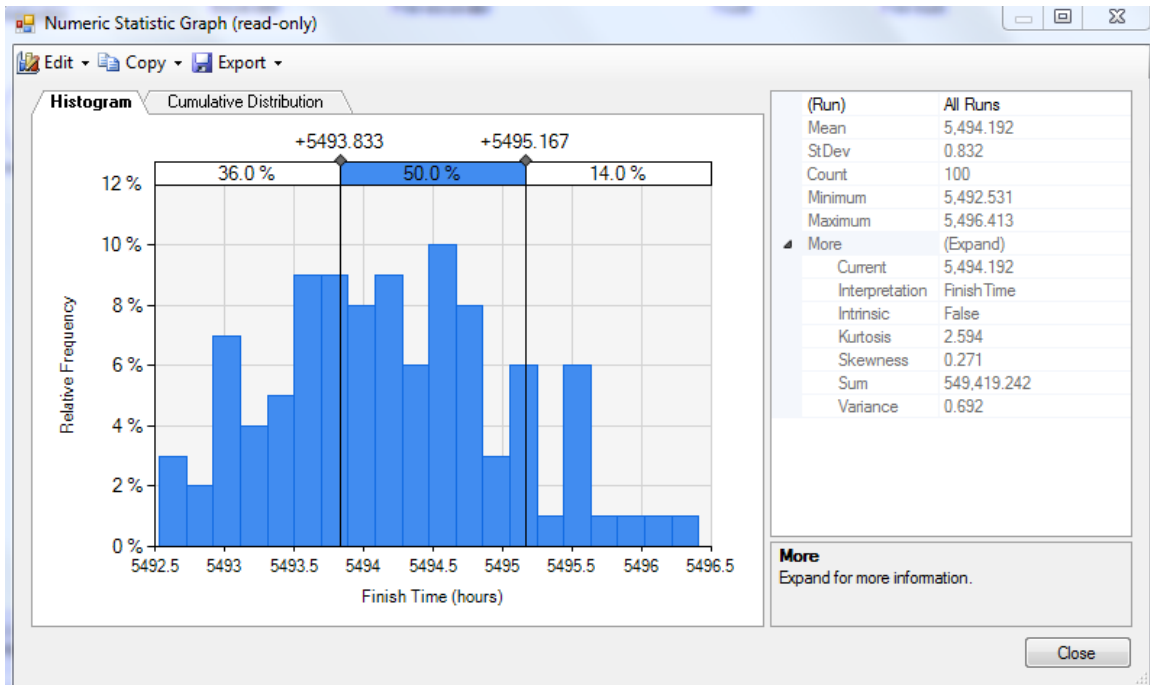




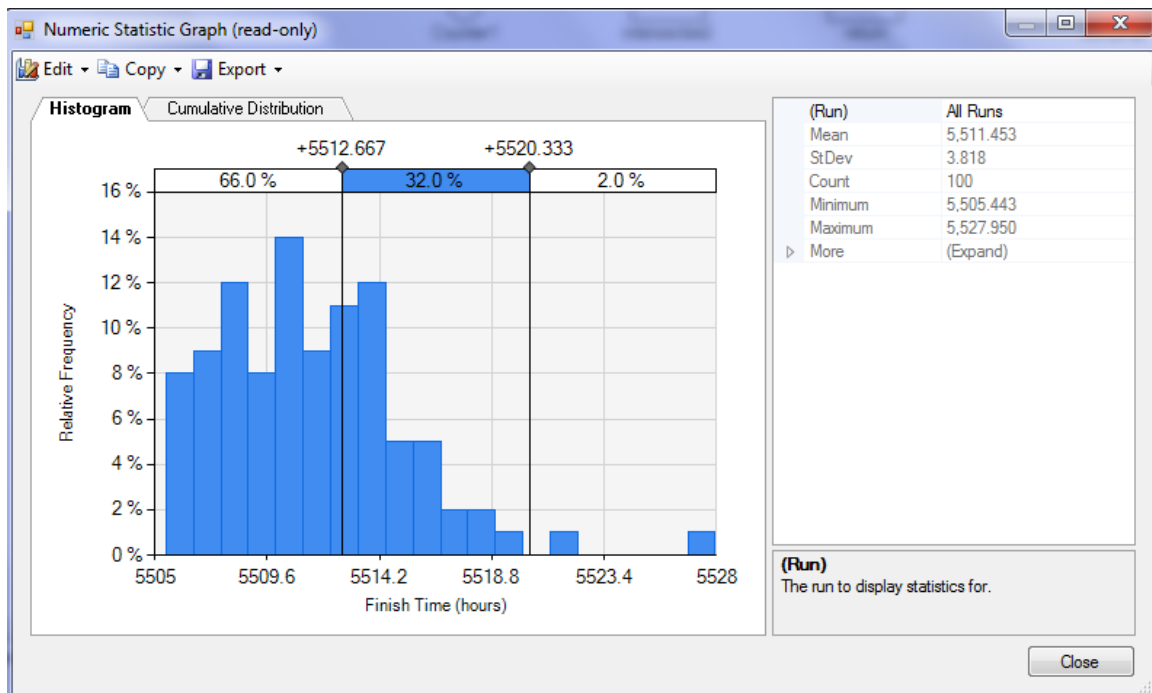
**Figure 30: General Symphony Model of Project**



**Figure 31: Scenario 1—Project Results With Tire Usage**



**Figure 32: Scenario 2—Project Results Without Tire Usage**



**Figure 33: Scenario 3—Project Results Without Tire Early Failure**

From the results, it can be found that tire usage has effects on the total duration. If not considering tire usage, the project total duration is around 5494.192 hours, whereas the project duration considering tire usage is 5512.72 hours. The project duration will be delayed by 18.528 hours for replacing the tires. There are around 34 tires worn out, in which 5 tires suffer from early failure, and 29 tires are normally worn out. Compared to the total project duration, the delay doesn't cause a big effect. However, the cost of tires cannot be neglected. The total direct cost is \$9,738,000 including the excavator and trucks. The total cost for tire usage is around \$1,320,000, which is a considerable amount. If not considering the early failure time, the project duration is 5511.453 hours, which is almost the same as

the results that considers the tire early failure. The number of worn out tires is 30, which is 4 tires less than the scenario considering early failure. The effect on the costs is not a big problem, while the effect on the cash flows and procurement may be a big issue. If the size of this project is amplified twice, then 2 excavators and 12 trucks are required. The project duration is almost the same, but the number of early failure tires is twice of the original project under the same duration. This means that more tires will be used than expected, so companies need to pay more attention to the risks of early failure. It may greatly affect the procurement of the project. If the tires are out of stock when they are needed, the project will be delayed much more than expected.

#### **4.3.2 Summary**

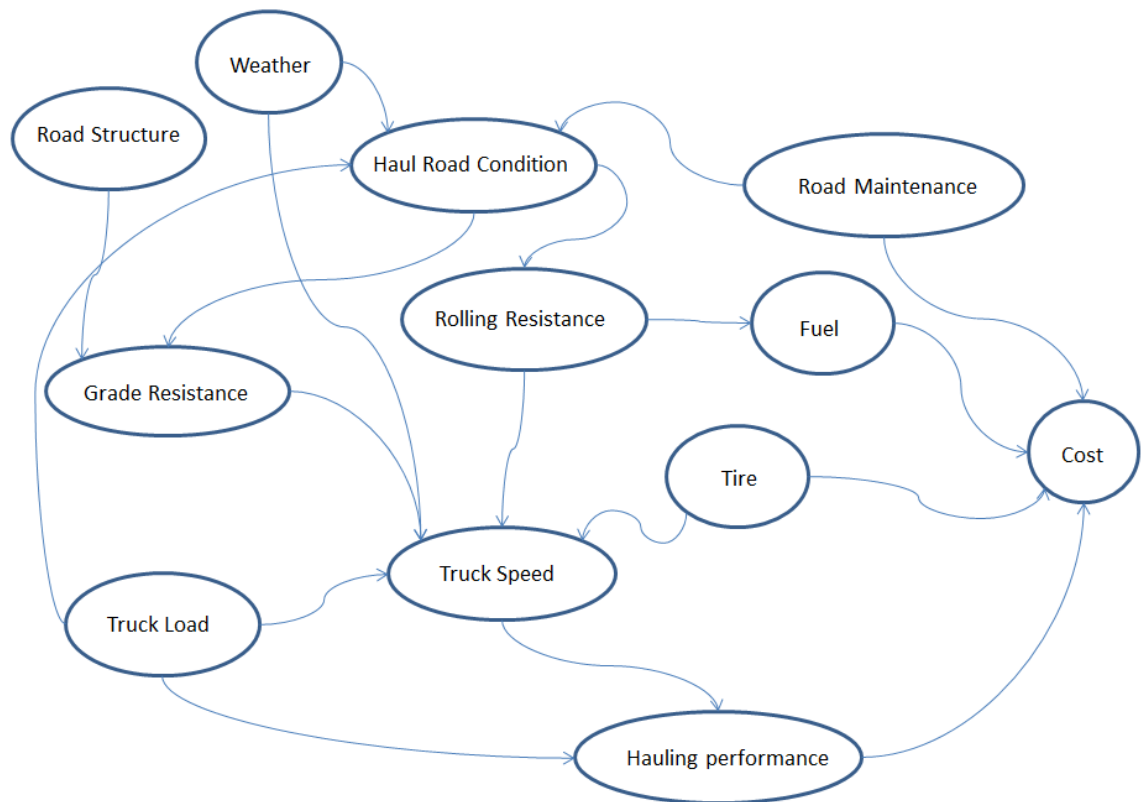
Due to restrictions of large earth moving companies' regulations, historical data sets of tire usage are confidential. Therefore, no real data could be used to validate the tire usage simulation process. There are also some limitations in this tire usage simulation process. First, this process cannot reflect the real cash flow situations when purchasing new tires during the projects, because the tire usage process is different from the traditional industrial practice. Second, the actual tires required for replacement will be a little bit more than the simulation results. In the real situation, when the tires suffer from early failure, in order to keep balance of the trucks, sometimes the tire on the other side of the truck has to be replaced by a new tire as well. Therefore, more tires will be required. The results of the tire

usage simulation are relatively conservative. Therefore, considering the risks of tire early failure, companies should pay more attention to their tire usage plans when doing large earth moving projects. Companies can adjust their plans by simulating the tire usage and the early failure status in the project with the Symphony model.

## **4.4 Haul Road**

### **4.4.1 Introduction**

Haul roads are the connection between the source site and the dump site. The conditions of haul roads can affect the hauling speed of trucks and their operational costs. For those relatively small on-road trucks, the effect of haul road conditions on the truck's speed is small, whereas for large off-road trucks, especially those large trucks used in surface mining with over 200-ton capacities, trucks can seriously deteriorate the haul road conditions so that will seriously affect the hauling performance. The interactions between trucks and haul roads are shown in Figure 34 below.



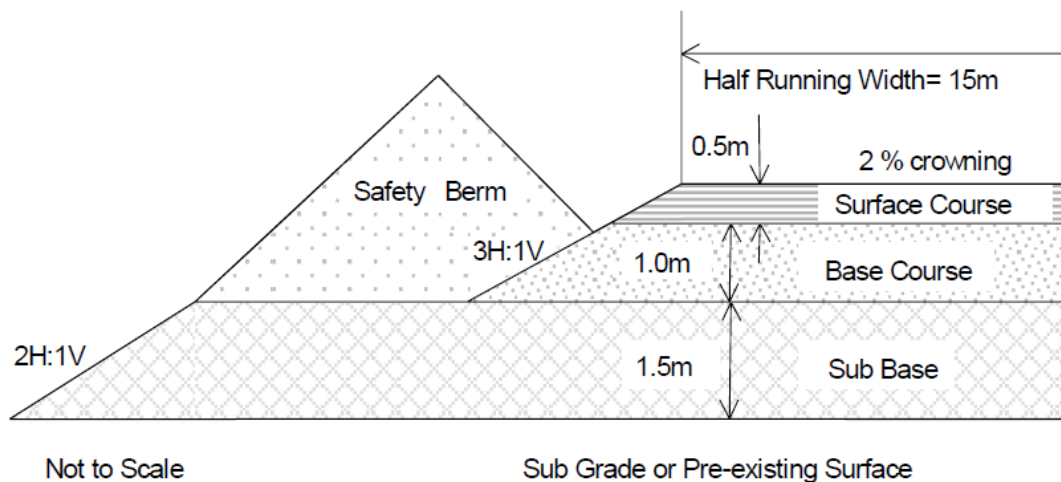
**Figure 34: Influence Diagram of Haul Road**

The interactions between haul road, truck, hauling performance, and cost are complicated. Road structure, weather, truck load on the road, and road maintenance will affect the haul road conditions, while haul road conditions will affect the hauling performance and the tire usage. In addition, the hauling performance, haul road layout, road maintenance, tire usage, and fuel consumption will affect the direct and indirect costs of earth moving projects. Therefore, haul roads are one of the biggest potential risks in large earth moving projects. Bad haul road conditions will increase both the project time and cost. In order to optimize the earth moving operations, research has been done on haul

road design, road maintenance, and road layout. Kang optimized the haul road layout for long distance routes between one origin and one destination in mining projects in 2013. Chang Liu and Ming Lu (2013) optimized the temporary haul road networks between multiple origins and multiple destinations.

#### 4.4.2 Haul Road Structure

The haul road structure is similar to the road structure in the city area. The only differences are the detailed specifications and the material used in construction. Typical haul road structure is shown in Figure 35 (Tannant, Regensburg 2001). It is a cross section of a typical haul road.



**Figure 35: Cross Section of Haul Road (Tannant and Regensburg 2001)**

There are four layers, namely, sub-grade, sub-base, base course, and surface (Tanant and Regensburg 2001). Sub-grade is comprised of native in-situ soil or

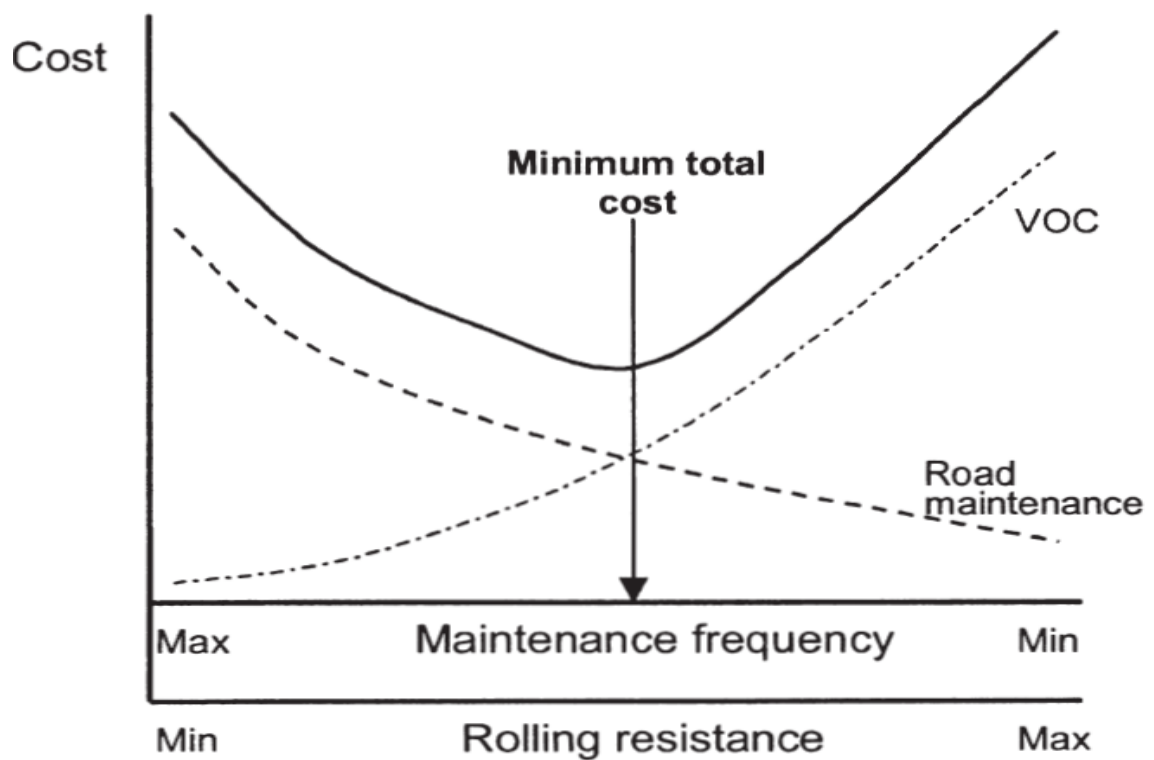


rock, previously placed landfill, muskeg, or other existing surfaces over which a road is to be placed. If the sub-grade is made of soft materials which lack the required bearing capacity, compaction or geotextile will be used. Sub-base is the layer between sub-grade and base course. It usually consists of compacted granular such as coarse gravel. The sub-base is designed for providing enough strength to the road, minimizing frost effects and accumulation of water in the road structure. Base course is the layer directly beneath the surface course, which is the main source of the structure strength of the road. It is made of high quality compacted material with smaller particles than the sub-base. Surface course is the top layer of the haul road which will decide the adhesion to the road and the rolling resistance. Adhesion is important from a safety aspect of keeping the haul truck from sliding off the road. The general types of material are compacted gravel, crushed stone, asphaltic concrete, roller compacted concrete, and stabilized earth. Different surface materials will have different specifications, and it will cause different issues during earth moving operations and maintenance. If loose surface material is used, then dust will be a big safety issue.

#### **4.4.3 Road Maintenance**

Road maintenance is important for keeping the haul road conditions in good status. No matter how well the haul road is designed and constructed, road deterioration cannot be avoided, even if the best quality material is used. For those large earth moving projects like surface mining and dam construction, large trucks with

hundreds of tons of capacities will have more effects on the haul road deterioration. In order to ensure hauling efficiency, the road needs to be maintained after a period of time. The road maintenance will cost a lot of money; however, if the road is not maintained, the bad road conditions will increase the fuel consumption and reduce the hauling efficiency, which will increase the operational cost as well. Therefore, many researches have attempted to find the best maintenance strategy that can reduce the maintenance cost and find the balance between maintenance cost and vehicle operating costs (VOC). Figure 36 is a plot showing the relationship between maintenance frequency and maintenance vehicle operating costs (Thompson 2003). The minimum total cost and the corresponding road maintenance frequency are shown in the plot as well.



**Figure 36: Plot of Relationship between Maintenance Frequency and Maintenance Cost (Thompson 2003)**

In order to measure the vehicle operating costs associated with haul road conditions, Thompson (2003) made a complicated predictive model for rolling resistance progression with time.

The relationship between rolling and roughness defect score are determined by a series of equations:

$$RR = RR_{MIN} + RDS \cdot \exp^{(LDRRI)}$$

$$RRMIN = \exp^{(-1.8166+0.0028V)}$$

$$LDRRI = 6.068 - 0.00385RDS + 0.0061V$$

$$RDS = RDSMIN + \left[ \frac{RDSMAX - RDSMIN}{1 + \exp^{LDRDI}} \right]$$

$$LDRDI$$

$$= 1.768 + 0.001D(2.69KT - 72.75PI - 2.59CBR - 9.35GC + 1.67SP)$$

$$RDSMIN = 31.1919 - 0.05354SP - 0.0152CBR$$

$$RDSMAX = 7.6415 + 0.4214KT + 0.3133GC + 0.4952RDSMIN$$

Where RR = rolling resistance; RRMIN = minimum rolling resistance; V = velocity (km/hr); LDRRI = rate of change in rolling resistance, which is a linear combination of independent variables; RDS = roughness defect score; RDSMIN = minimum roughness defect score at time 0; RDSMAX = maximum defect score; LDRDI = linear combination of the independent variable for the rate of RDS increase. The rest of the variables are listed in Figure 37.

Independent variable	Description
D	Days since last maintenance
KT	Average daily tonnage hauled (kt)
PI	Plasticity index
CBR	100% Mod. California Bearing Ratio of wearing course material
GC	Grading coefficient, defined as; $\frac{(P_{265} - P_2) \times P_{475}}{100}$ where P <sub>265</sub> = percentage of material passing the 26.5 mm sieve P <sub>2</sub> = percentage of material passing the 2.0 mm sieve P <sub>475</sub> = percentage of material passing the 4.75 mm sieve
SP	Shrinkage product, defined as; $LS \times P_{425}$ where LS = Bar linear shrinkage

**Figure 37: Variables for the LDRDI (Thompson 2003)**

Based on the prediction model of rolling resistance, Thompson generated some equations for calculating the fuel consumption and the tire consumption. There are two fuel consumption equations, which are classified by total resistance: favorable (i.e. GR+RR>0%) and unfavorable (i.e. GR+RR<0%). However, these equations used in analyzing the relationship between road maintenance costs and the vehicle operating costs are very complicated and have many variables. Since earth moving is a dynamic process, it will increase the complexity of modeling

haul road effects on the time and cost in the whole process by using the equations provided by Thompson.

#### **4.4.4 Proposed Research Method by Neural Network and Simulation**

The relationship between haul roads and hauling performance is complicated. Thompson's equations involve many dependent and independent variables, which will increase the complexity in analyzing the haul road effects. Using neural networks and simulation methods may simplify the research on haul road effects. Before developing the conceptual methods in analyzing the haul road effects in earth moving projects, the relationship between the haul road, vehicle operation, road maintenance, and operating cost should be identified clearly. First, the haul road conditions can directly determine the rolling resistance in cooperating with truck gross weight, and weather conditions, which will finally affect the speed. The fuel consumption of the truck during the hauling operations is affected by the age of equipment, speed, and road conditions. The road conditions are affected by road maintenance frequency, road type, and the daily loads passed (tones/day).

For dealing with these complex relationships, neural network is a good tool to figure out the linear and nonlinear relationships among the inputs and outputs. In addition, neural network can also be combined with a simulation model, which can simulate the haul road effects on the whole project duration and cost. Three neural networks should be developed and trained.

The first neural network is developed for predicting the maintenance cost and road conditions. The inputs and outputs are listed in Table 7.

1 <sup>st</sup> Neural Network for Road Conditions			
Input	Unit	Output	Unit
Maintenance Interval	days	Cost per Maintenance	\$
Surface Material	name	Road Deterioration Rate	Grade/day
Road Type	Temporary, Semi- Temporary, Permeant	Increment of Road Condition After Maintenance	Grade
Daily Loads Passed On the Road	Tons/day		

**Table 7: Input and Output for 1<sup>st</sup> Neural Network in Haul Road Simulation**

### **Process**

The road condition can be graded from 0 to 100. For a new construction haul road, the road condition grade (RCG) is 100. For a totally deteriorated road, the RCG is

0. All of the roads in use will have a life time, even if they are maintained frequently. Maintenance can only slow down the roads' deterioration. After a period of time before road maintenance, the road will be deteriorated to a certain degree. The daily road deterioration is calculated as the difference of RCGs between two continuous maintenances. It will be used to calculate the road conditions in each simulation day. After maintaining the haul road, the road conditions will have a certain increase in the grade. The incremental amount in the grade of road conditions will be estimated, and will be used in calculating the haul road conditions right after the maintenance. The total loads passed on the haul road every day will be recorded, because the total truck load is an important factor that can determine the road deterioration rate. By collecting enough data sets, the neural network can be constructed and trained. There are four inputs: maintenance interval, surface material, road type, and daily loads passed on the road. The outputs are cost per maintenance, road deterioration rate, and increment of increase in road conditions after maintenance.

The second neural network is developed for predicting the fuel consumption for each truck load. The inputs and the outputs are listed in Table 8 below.



2 <sup>nd</sup> Neural Network for Fuel Consumption			
Input	Unit	Output	Unit
Equipment Age	Years	Fuel Consumption for Each Truck Load	Gallon/Load
Driving Type	Aggressive(1), Conservative(0)		
Speed	km/hr.		
Road Condition	Grade		
Weather Conditions	Maximum, Minimum Temperature, and Precipitation		
Length	km		
Grade Resistance	%		
Gross Weight	Ton		

**Table 8: Input and Output for 2<sup>nd</sup> Neural Network in Haul Road Simulation  
Process**

Before developing and training this neural network, the data for these inputs and outputs should be collected first. The driving type is determined by drivers' habits. Under the safety operation regulations, different drivers will have different driving habits which will affect the fuel consumption. The driving types here are simply divided into two types: aggressive and common. For road conditions, weather conditions can be inspected and recorded every day.

The third neural network is developed for predicting the speed. When discussing the weather effects on the trucks' speed in the previous section, a neural network was developed and trained. That neural network for predicting the truck speed is limited by the historical data sets. The historical data sets only recorded the payload, average loaded speed, empty speed, and temperature for each truck load, but the speed is also affected by grade resistance, road conditions, drivers' driving type, and equipment age. Therefore, the inputs of the neural network for predicting speed are almost the same as the neural network for predicting the fuel consumption. The inputs and the output are listed in Table 9 below.

3 <sup>rd</sup> Neural Networks for Truck Speed			
Input	Unit	Output	Unit
Equipment Age	Years	Truck Speed	km/hr.
Driving Type	Aggressive(1), Common(0)		
Road Condition	Grade		
Weather Conditions	Maximum, Minimum Temperature, and Precipitation		
Grade Resistance	%		
Gross Weight	Ton		

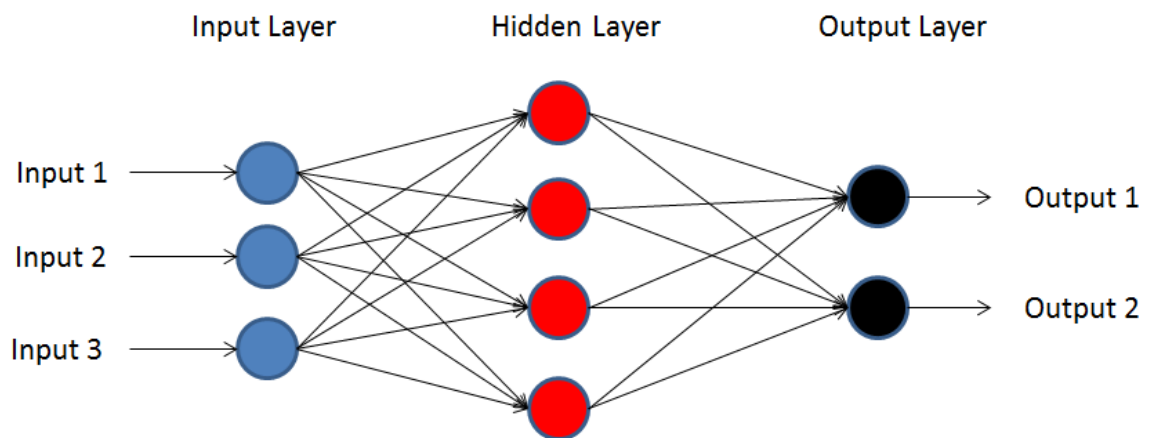
**Table 9: Input and Output of 3<sup>rd</sup> Neural Network in Haul Road Simulation**

### Process

#### 4.4.5 Neural Network Testing and Validation

By consulting industrial experts, collected historical data combined with simulated data are used to train and test these three neural networks. The typical three-layer radial basis function neural network (RBFNN) is used, as shown in

Figure 38. There are five neurons in the hidden layer. The activation function is Gaussian function. The output of neural network is a scalar function of the input vector.



**Figure 38: Sample of 3-Layer Artificial Neural Network Used in Haul Road**

### **Analysis**

The predicted values generated by mature neural networks are compared with actual values, and the sensitivity analysis will be done to test and validate the neural networks. Figures 39, 40, 41, 42, and 43 show the comparison between

predicted values and actual values.

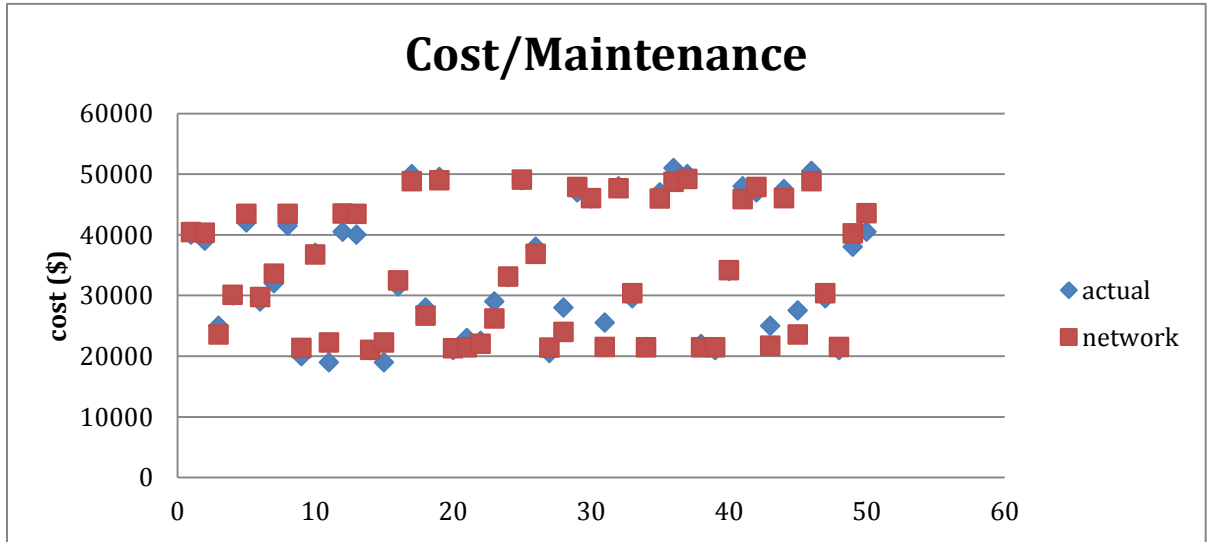


Figure 39: Cost per Maintenance in 1<sup>st</sup> Neural Network

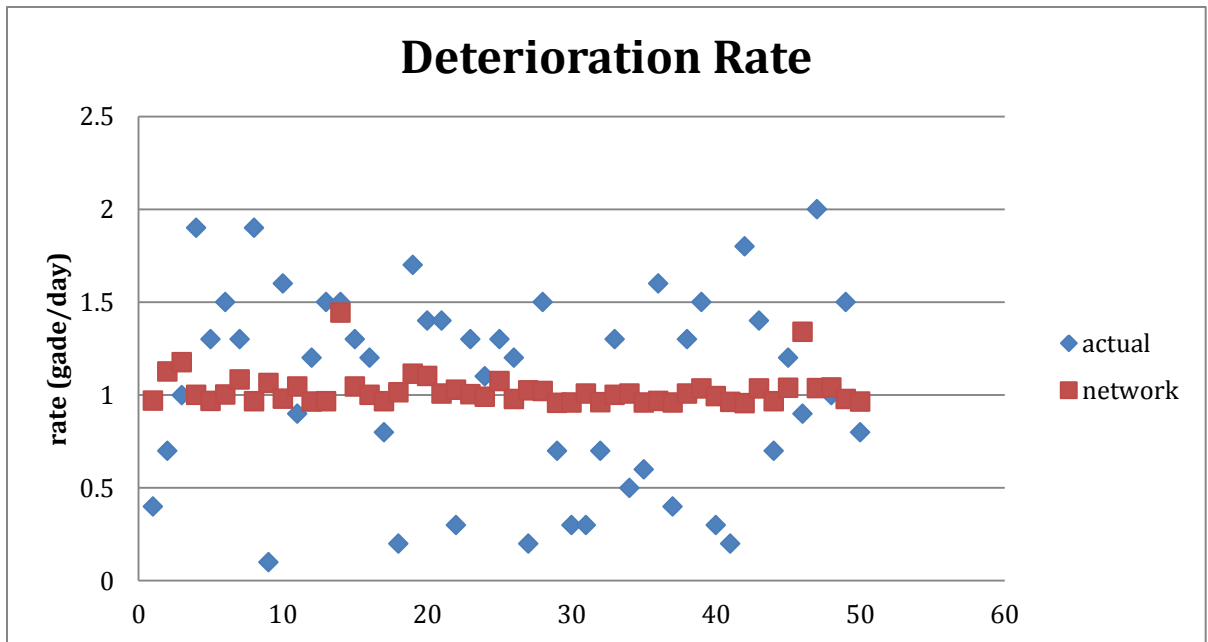
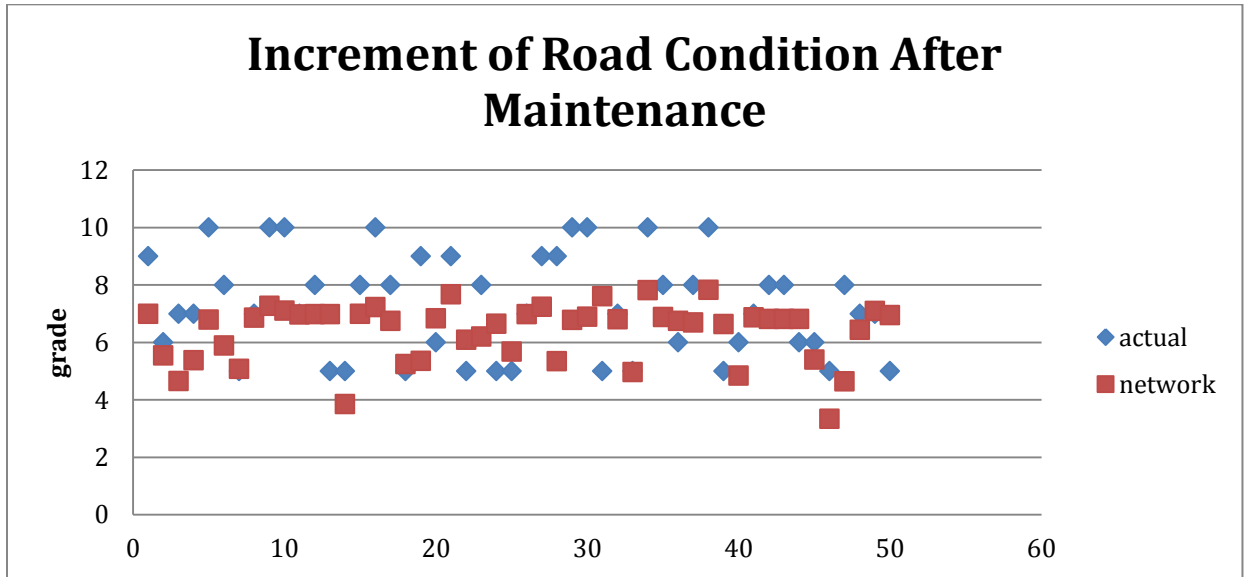
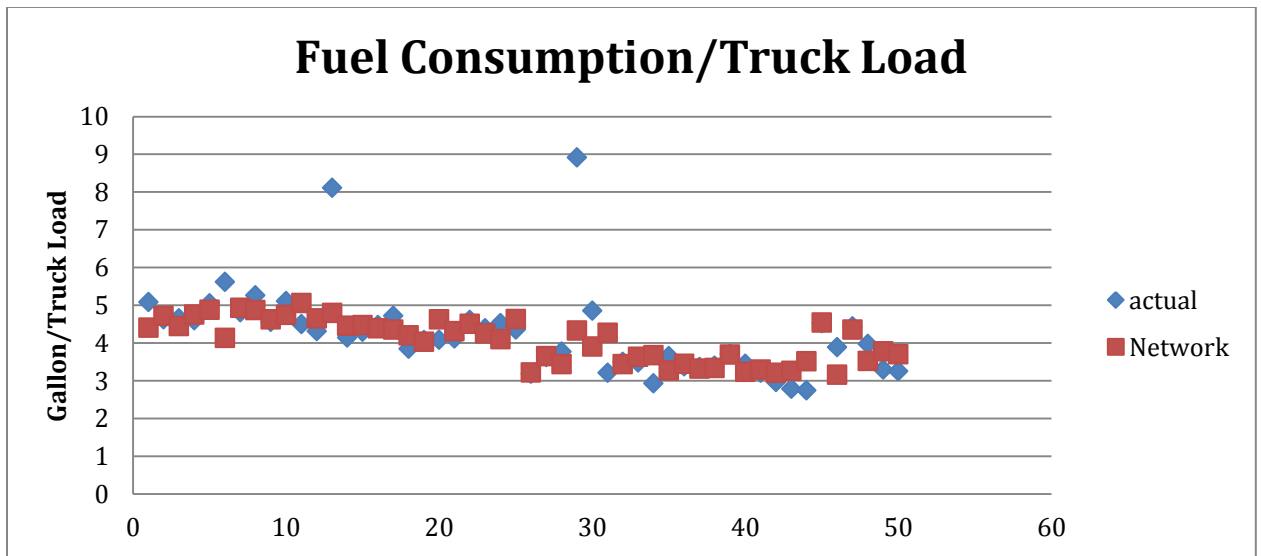


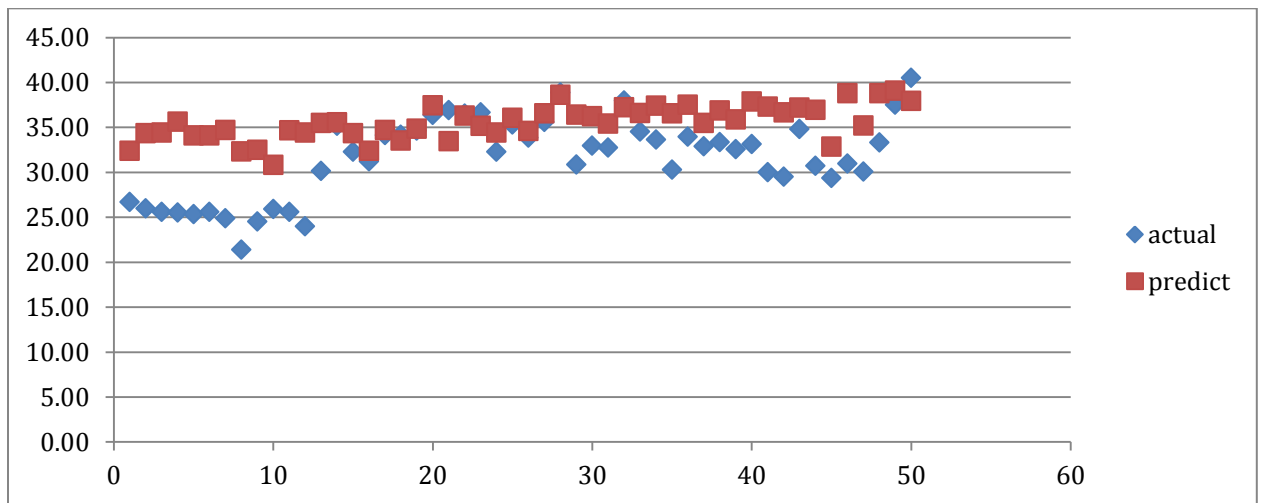
Figure 40: Road Deterioration Rate in 1<sup>st</sup> Neural Network



**Figure 41: Increment of Road Condition after Maintenance in 1<sup>st</sup> Neural Network**



**Figure 42: Fuel Consumption per Truck Load in 2<sup>nd</sup> Neural Network**



**Figure 43: Truck Speed in 3<sup>rd</sup> Neural Network**

Figures 39, 40, and 41 show the comparison between the predicted outputs in the 1<sup>st</sup> neural network and the actual values. The predicted costs per maintenance are perfectly fit to the actual values. On the contrary, the curve of predicted deterioration rate is very flat, and the values concentrate within a small range which is different from the actual values. Most of the predicted values of increment of road condition after maintenance in Figure 41 are fit to the actual values. There are some other values which are much smaller than the actual values. Figure 42 shows the comparison between the predicted fuel consumptions and the corresponding actual values. The curve is perfectly fit except 3 points which are much larger than the predicted values. The curve for predicted truck speed is similar to the curve for actual values in Figure 43. Some of the predicted values are larger than the actual values.

Maintenance interval, precipitation amount, and road conditions are key factors in the haul road maintenance and vehicle operating cost. The maintenance interval will affect the maintenance cost and road conditions in projects. The precipitation amount and road conditions can affect the trucks' operational efficiency and cost. By doing the sensitivity analysis of these factors in the neural network, it is found that the maintenance interval has great impacts on the cost per maintenance. As shown in Table 10, when maintenance interval increases, cost per maintenance increases as well. On the contrary, deterioration rate decreases. From Tables 11, 12, and 13, it is observed that fuel consumption per load will increase as truck speed increases. Bad road conditions will cause more fuel consumption. In contrast to road conditions, precipitation can help reduce the fuel consumption, because precipitation can reduce rolling resistance. In addition, precipitation can reduce the truck speed as shown in Table 14.

	Maintenance Interval	Cost per Maintenance	Deterioration Rate	Increment after Maintenance
min	3	22377	1.0294	7.4988
median	9	33096.96	0.9905	6.6856
max	15	49251.125	0.95087	6.766

**Table 10: Sensitivity Analysis of Maintenance Interval**



	Speed (km/hr.)	Fuel Consumption (Gallon/Load)
min	25	4.26
median	35	4.3
max	45	4.432

**Table 11: Sensitivity Analysis of Truck Speed**

	Road Condition (Grade)	Fuel Consumption (Gallon/Load)
min	50	4.587
median	75	4.426
max	100	4.26

**Table 12: Sensitivity Analysis of Road Condition**

	Precipitation (mm)	Fuel Consumption (Gallon/Load)
min	0.2	4.832
median	10	4.71
max	20	4.587

**Table 13: Sensitivity Analysis of Precipitation versus Fuel Consumption**

	Precipitation (mm)	Speed (km/hr.)
min	0.2	32.02
median	10	31.4
max	20	31.18

**Table 14: Sensitivity Analysis of Precipitation versus Speed**

According to the test and sensitivity analysis, these three neural networks are validated to help identify the relationship between inputs and outputs and predict accurate output. There are some limitations in use of these matured neural networks. First, the 1<sup>st</sup> neural network can only predict the maintenance cost and road deterioration rate of temporary haul road with compacted gravel as surface material. Second, the 2<sup>nd</sup> and 3<sup>rd</sup> neural networks can only predict the fuel consumption and speed of a certain type of truck. If people want these three neural networks to be more functional, more data will need to be collected for other types of haul roads with different surface materials and different types of trucks, and then more accurate and functional neural networks can be done to be used in analysis.

#### **4.4.6 Simulation Model**

The mature neural networks can be embedded in the simulation model to provide the required data. The flowchart for haul road simulation is shown in Figure 39.

Before the simulation starts, users should manually input the haul road properties, which are equipment ages, driving type, grade resistance, empty truck weight, road type, surface material, proposed daily loads, and maintenance interval. At the start of simulation, the proposed daily load will be used to activate the first neural network to generate the road deterioration rate (RDR), which is used to calculate the RCG for the next day using the following equation:

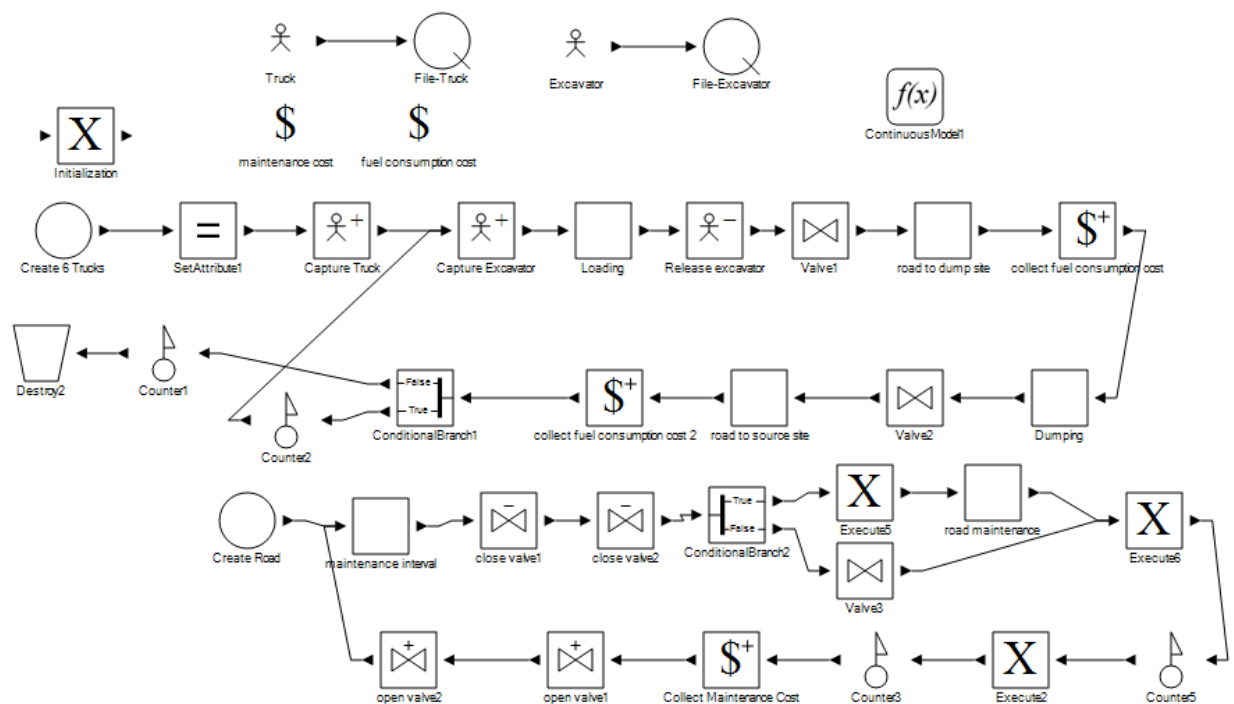
$$RCG_{i+1} = RCG_i - RDR_i \quad i = [1, n]$$

If it is the first day,  $RCG_1$  is 10. After loading the truck is finished, the gross weight of the truck should be calculated based on the loaded volume, the soil density, and the weight of the truck itself. Then the hauling speed can be generated by activating the third neural networks based on the current day's RCG. When the dirt has been dumped, the truck's returning speed can be calculated by the third neural network as well. The dump load should be recorded to calculate the total loads passed on the road for the current day. It will be used to generate the fuel consumption of each load when returning to the loading site. If it is the first day, the proposed daily loads will be used to activate the first neural network, if it is not the first day then the daily loads used in calculating the fuel consumption will be generated based on the previous day's total loads. When maintenance time arrives, all hauling operations will be shut down until maintenance is finished. The maintenance cost and the increment of road condition improvement will be generated by activating the first neural network.

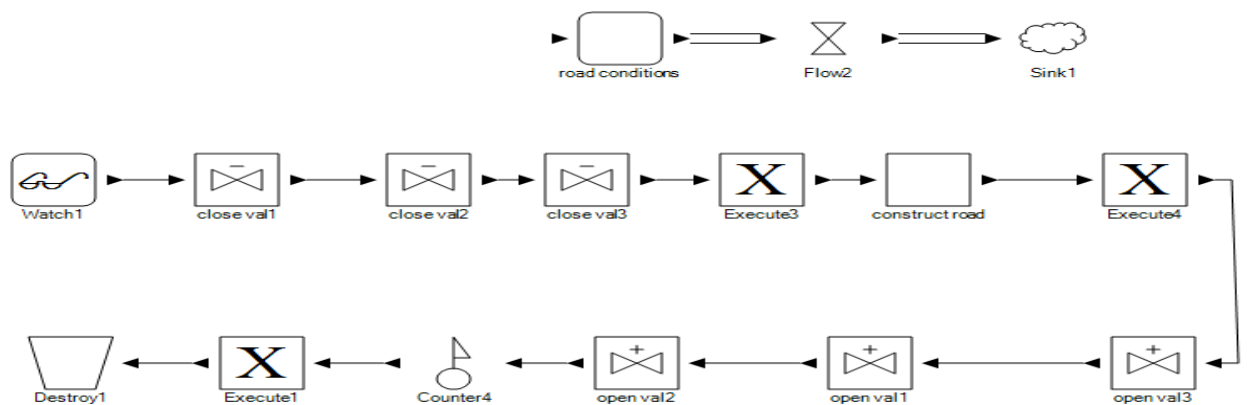
The RCG for the proceeding day will add the increment amount for maintenance. This process will be repeated for each simulation day. At the end of simulation, the total maintenance times and costs will be recorded, and the total fuel consumption cost will be calculated as well.

#### 4.4.6 Model Testing and Validation

Based on the algorithms in the flowchart, a Symphony general purpose simulation model has been developed. The developed three neural networks are embedded in the model. The model is shown in Figure 44, and the Figure 45 shows the elements in the continuous model.



**Figure 44: Symphony General Purpose Model for Haul Road**



**Figure 45: Continuous Model in General Purpose Simulation Model**

In order to test and validate the model, a large earth moving project is used in the model. There one excavator and six trucks in the projects. The total soil amounts to be moved are 6000000 BCMs. The simulated result of total project duration is almost the same as the result calculated by industrial practice so that it can be used in the analysis. The purpose of this simulation model is to analyze the relationship between maintenance frequency and vehicle operational cost. By comparing the results generated by three different scenarios as shown in Table 15, the relationships can be found. Three different maintenance intervals are used in the model by keeping other inputs intact. From the results in Table 15, it can be found that maintenance interval will affect the project duration, maintenance cost, and fuel consumption cost. When maintenance interval increases, total maintenance times reduce so that total project duration decreases. Even if the cost per maintenance increases as the maintenance interval increases, the total maintenance cost decreases. When the maintenance interval increases, the total

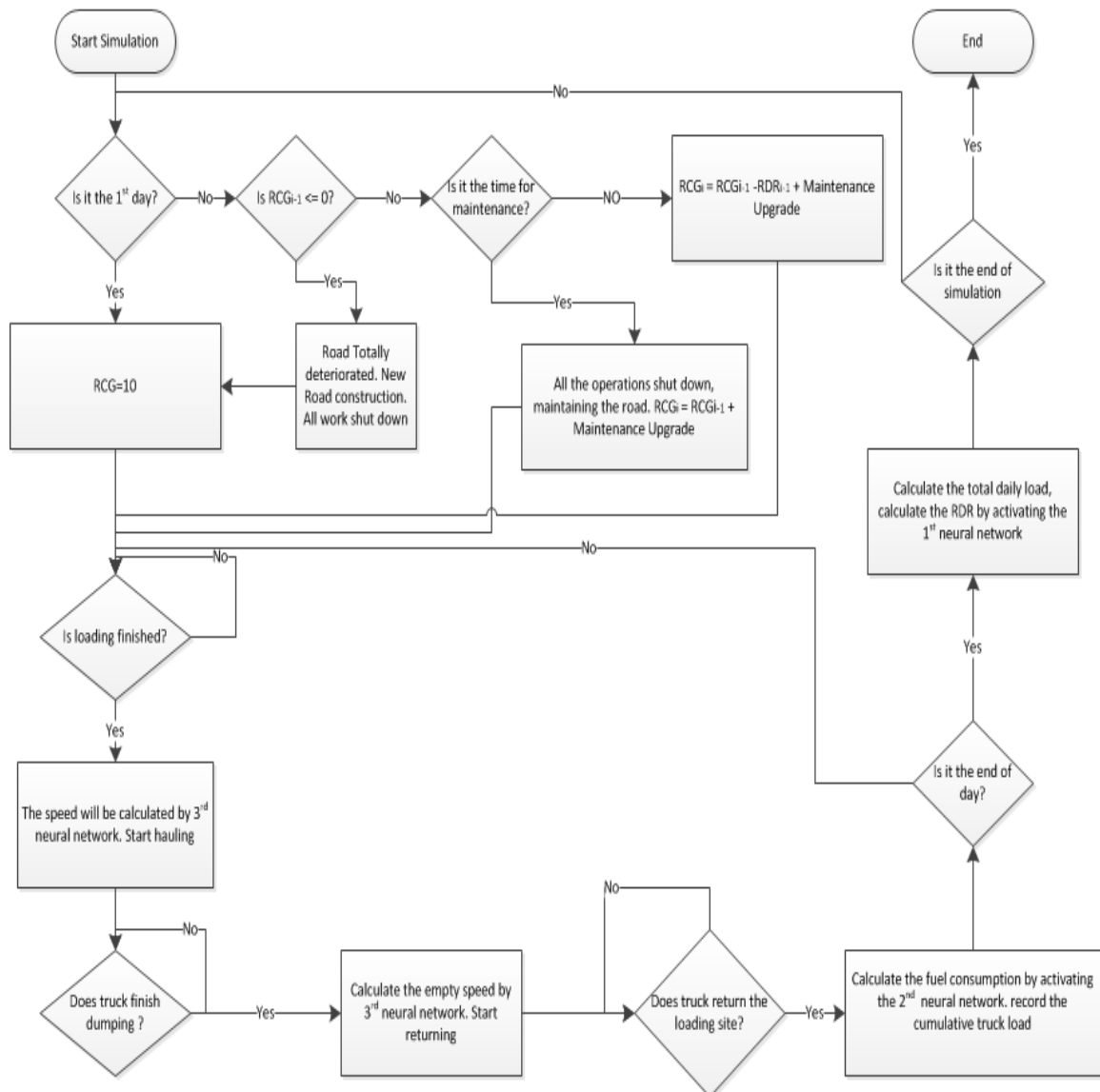
fuel consumption cost only increases a small amount. Comparing with this to the effects on total maintenance cost, maintenance interval has a small effect on total fuel consumption cost. The total cost decreases as the maintenance interval increases. If the maintenance interval keeps on increasing, the total cost may start increasing at a specific point. With the restriction of lack of data, the maximum maintenance interval is 15 in the training data, so the neural network cannot accurately predict the results when maintenance interval is over 15. However, by comparing these three scenarios, it can be observed that the impacts of maintenance interval on maintenance cost decrease as it increases, while the impacts on total fuel consumption cost increase. Therefore, the minimum total cost can be achieved when maintenance interval keeps on increasing.

Maintenance Interval (Day)	Total Project Duration (hours)	Total Maintenance Cost (\$)	Total Fuel Consumption Cost (\$)	Total Cost (\$)
3	4260.91	1253112	1818364.15	3071476.2
9	4086.6	595745.28	1817833.22	2413578.5
15	4056.4	541762.38	1862733.56	2404495.9

**Table 15: Effects of Maintenance Interval**

#### 4.4.7 Summary

The relationships between maintenance interval and maintenance cost, or vehicle operational cost are almost the same as Thompson (2009) presented in Figure 36. Therefore, this simulation model is validated. If more data is collected in the future, the neural networks in this model can be improved so that the model can generate more precise results for further analysis. The neural networks can also be embedded in Symphony earth moving template which will make it convenient for industrial practitioners to build the model and analyze the haul road effects themselves.



**Figure 46: Haul Road Simulation Process in Earth Moving Model**



## Chapter 5: Case Study

### 5.1 Introduction

In the decision support system, the third component is to do the risk analysis for the whole project. Symphony.NET is an important tool for providing both accurate estimation and risk analysis. Symphony.NET can handle discrete event simulation and continuous simulation. Discrete event simulation has been proven appropriate for modeling the earth moving process. In considering the risks in the earth moving process, the equipment productions will be stochastic values. For example, an excavator's production can range from 500 BCM/hr to 1000 BCM/hr. If construction companies choose 500 BCM/hr in the estimation, it means that they are very conservative, so the project will have little probability of overrun. Sometimes, due to the companies' objective in the new market or some other reasons, people want to use higher production in the estimation, so their bid price will be more competitive, and companies will have higher opportunity to win the bid. However, companies take on more risks at the same time. Now, companies mainly rely on engineers' experience and intuition to decide whether to do a risky bid or not. They don't clearly understand the probability they have that they can succeed in finishing the project on time. The general purpose template of Symphony.NET can easily model different kinds of earth moving processes and run Monte Carlo simulation for risk analysis by calculating the project completion

probability. A case study is presented here using Symphony general purpose template to explain how to analyze risks in earth moving projects.

## 5.2 Project Description and Modeling

The case is a large earth moving project in northern Alberta. Four types of soil will be excavated and hauled to the dump site. The soil types and their quantities are listed in Table 16 below.

Soil Type	Overburden	Silt	Clay	Sand
Quantity (BCM)	644192	1309756	1365365	3184119

**Table 16: Soil Type and Quantity**

There are 644,192 BCM overburden soil, 1,309,756 BCM silt, 1,365,365 BCM clay, and 3,184,119 BCM sand. The hauling distance is 5.675 km. Two types of equipment are selected: shovel and truck. The quantity, production, and speed of the shovel and truck are listed in Table 2. The historical data of the shovel's production is fit to a beta distribution, beta (4, 3, 1200, 1700). The truck's capacity is 100 BCM, and the truck speed is fit to a beta distribution as well. The loaded speed is beta (4, 3, 30, 40), while the empty speed is beta (4, 3, 35, 45). The average dumping time is 6 minutes. There is one intersection in the hauling and returning path. The waiting time at the intersection is assumed to be 1 minute for both hauling and returning. There are three assumptions when modeling the

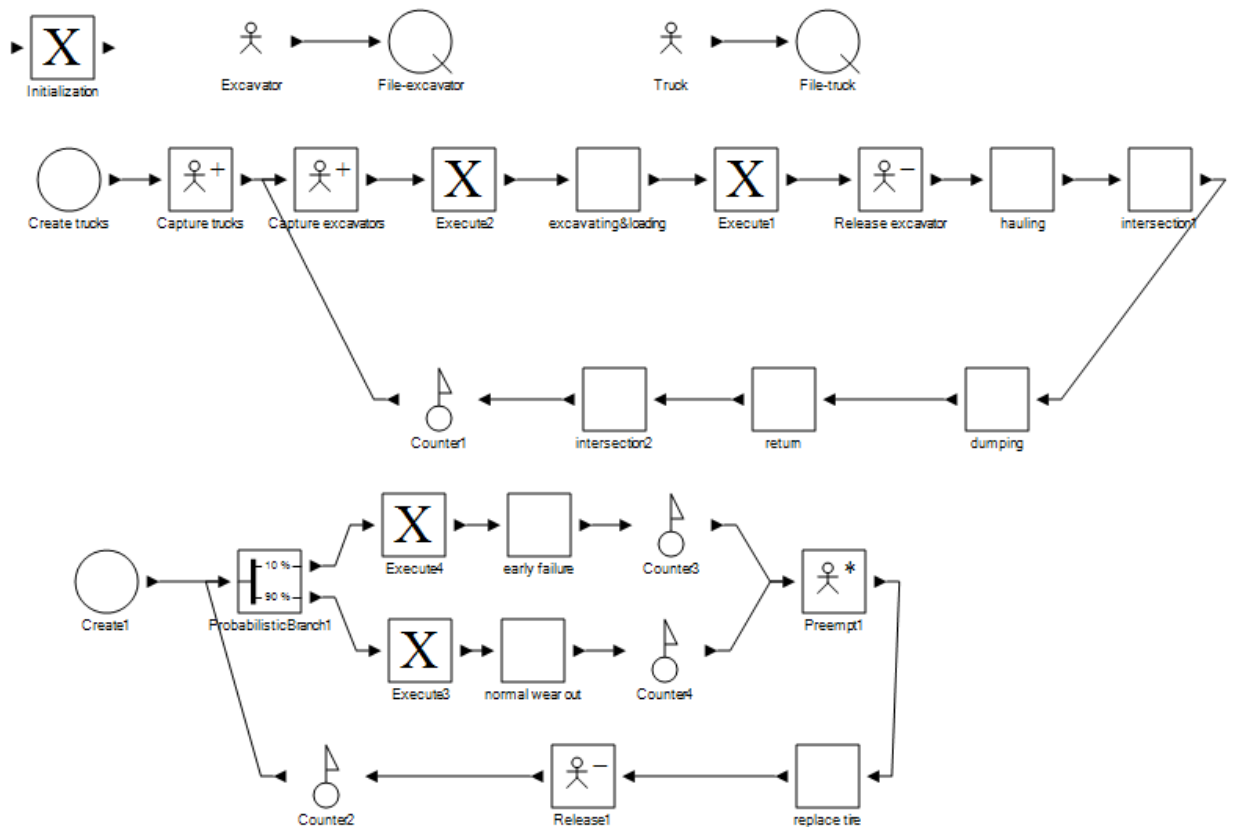
tire usage in the project. The normal wear-out tire life is assumed to be a triangular distribution, triangular (4500, 6000, 5000). The early failure tire life is assumed to be triangular (2500, 4000, 3000), and the tires are assumed to have 10% probability to suffer from early failure. The equipment types and quantities used in the project are listed in Table 17, together with their performance.

Equipment	Production/Speed	Quantity
Shovel	Beta (4,3,1200,1700)	1
Trucks	Beta(4,3,30,40)(loaded), Beta(4,3,35,45)(empty)	6

**Table 17: Equipment Performance**

The simulation model developed with the general purpose template is shown in

Figure 47.



**Figure 47: General Symphony Model for Case Study**

In this model, each truck should be paired with one excavator when loading the dirt. The rest of the trucks have to wait until the excavator finishes loading. Since four types of soils have been identified in the earth moving projects, there are some regulations in excavating and loading. The excavating and loading should start from top to the bottom. This means that the soil on the top should be excavated and loaded first. After finishing excavating and loading all the top soil,

the soil below can be excavated. In this earth moving project, the excavation starts from overburden soil, then silt and clay, and finishes with sand. The trucks used in the project are large 2-axle, 6-wheel mining trucks. When modeling the early failure of truck tires, 36 tires are created. Each tire has 10% probability of suffering from early failure. When the end of the tire life is reached, the truck will stop working and repair will begin.

### 5.3 Testing and Validation

As compared to traditional estimation method (Kevin 1998), production and speed of the excavator and the truck are the same as those used in traditional estimation, which are the mean values of the historical data. After running this deterministic model, the total project duration is shown in Table 18.

Total Project Duration (hr)	
Simphony Model	5511
Traditional Estimation	5660
Difference (absolute)	149
Difference (%)	2.6%

**Table 18: Comparison between Traditional Method and Simphony Model**

The total project duration predicted through traditional estimate is 5660 hours, while the total project duration calculated by the Symphony model is 5511 hours. The difference between these two types of estimation is 149 hours, or 2.6%. The difference in the duration mainly attributes to trucks' waiting time and position time. Since the difference is very small, the results made by Symphony model can be accepted.

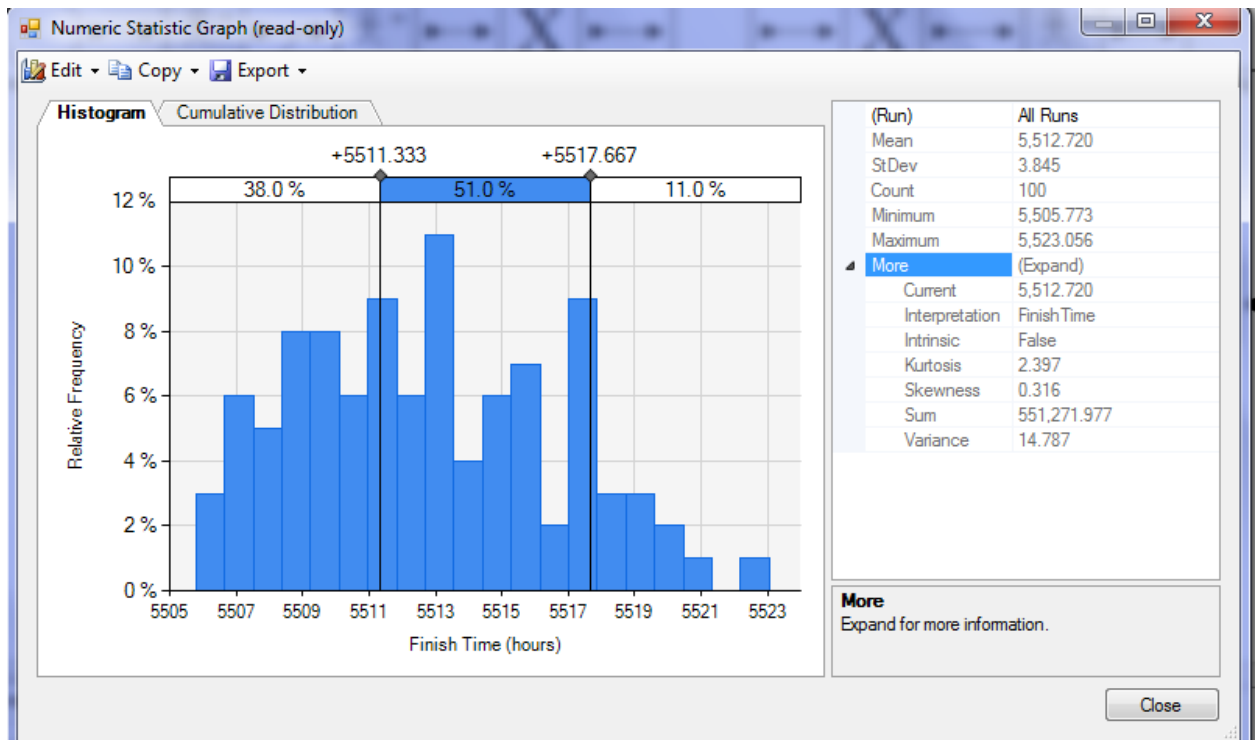
If the company wants to make a risky bid, it will choose larger production and speed. In contrast, the company will select relatively small production and speed in the estimate when it wants to make a conservative bid. In this project, by changing the excavator production and truck speed in the model to minimum and maximum values, then the model will generate the most conservative and risky total project duration, respectively. Table 19 lists and compares three different kinds of bids.

Bid Type	Most Risky	Intermediate	Most Conservative
Total Project Duration (hour)	5018	5511	6194
Excavator Utilization	78.6%	82.4%	92%

**Table 19: Comparison between Different Types of Bids**

From Table 19, it can be found that there are big differences in the total project duration between each type of bid. Since the cost of earth moving projects is mainly determined by the hourly rate of equipment and related crews, if the equipment types and fleet size are selected, the equipment production will greatly affect the estimated duration and costs. In order to win the bid, sometimes companies prefer to make a risky bid. However, that will increase the probability of overrun. Therefore, it is of vital importance to find out the probability completion within the expected duration if companies want to make risky bids.

For calculating the project completion probability, Monte Carlo simulation is required to model the earth moving operations. Symphony.NET can handle the Monte Carlo simulation. By changing the excavator duration and truck speed in the Symphony model in Figure 40 from constant values to beta distributions, the Monte Carlo simulation can be started by running the model 100 times. The results of 100 runs are listed in the statistic report in Figure 48 below.



**Figure 48: Stochastic Simulation Results**

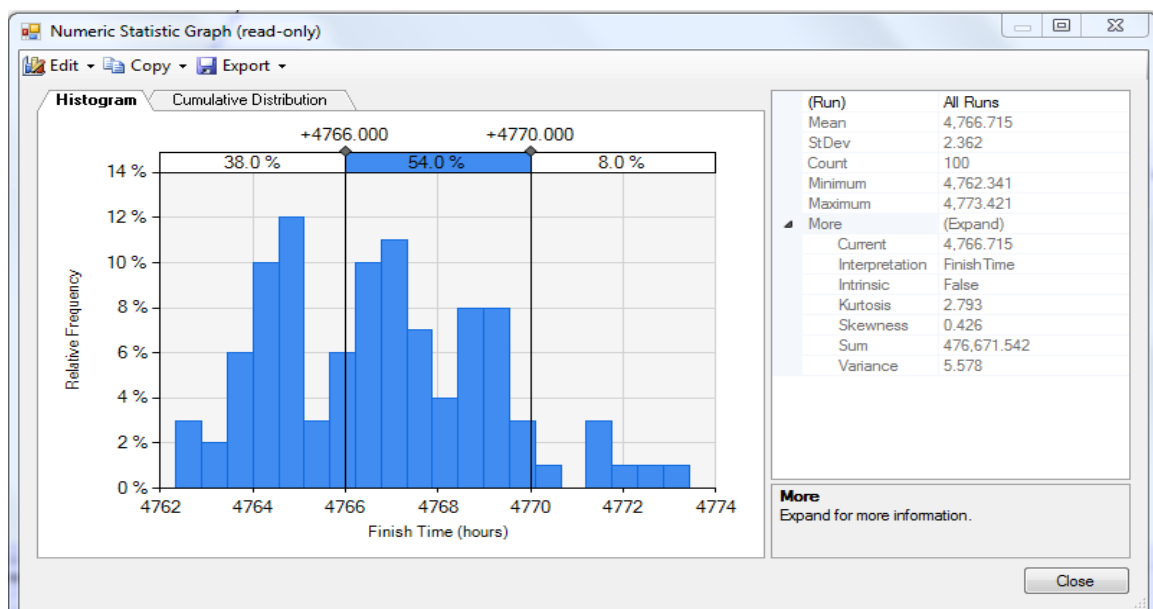
The mean values of project total duration for these 100 runs are 5512.72 hours, and the variance is 14.787. The minimum total duration in these 100 runs is 5505.773 hours, while the maximum total duration is 5523.056. The completion probability can be calculated with the following equation:

$$p(T \leq T_s) = \int_{-\infty}^{\frac{T_s - \bar{T}}{\sigma_T}} \frac{1}{\sqrt{2\pi}} \exp\left(-\frac{1}{2}t^2\right) dt = \Phi(z), \quad z = \frac{T_s - \bar{T}}{\sigma_T}$$

For the most risky bid, the total project duration is 5018, so  $z = -128.6$ . By checking the table of standard normal probability, the completion probability of a risky bid is below 0.02%. This means that the project likely cannot finish within



5018 hours. On the contrary, for the most conservative bid of this project, the completion probability is  $\Phi(177.2) \approx 99.99\%$ . It would be near impossible for the project to overrun. For the intermediate bid, the estimated total project duration is 5511, which is very close to the mean values. It is the mostly likelihood duration for this project, but it doesn't mean that the project will be 100% finished within 5511 hours. The completion probability of the intermediate bid is  $\Phi(-0.447) = 33\%$ . This low completion probability means that the risks in the operations still have a good chance to cause project overrun. If companies still want to finish the project within 5511 hours without sustaining large overrun probability, they can try to add one more truck to the project. Then, the equipment combination will be 1 excavator and 7 trucks. By changing the inputs in the Symphony model and running 100 times again, the simulation results are shown in Figure 49 below.



### Figure 49: Simulation Results for 1 Excavator and 7 Trucks

The mean project duration reduces to 4766.715 hours, and the standard deviation is 2.362. The utilization of the excavator is 95%. The completion probability is  $P(T < 5511) =$

$\Phi(315.1) \approx 99.999\%$ . In comparison with 6 trucks, the direct cost will increase by using 7 trucks, but the project will definitely be completed within 5511 hours.

Simphony GPT in the decision support system can provide construction companies an earth moving modeling tool and help do the risk analysis. Based on the data sets collected in the first component and the risk assessment in the second component of the decision support system, companies can estimate and do risks analysis using Simphony GPT first, and then make decisions based on the tender's requirements, the companies' own bidding strategy, and their risk tolerance. It will be clearer for companies to understand how many risks they may sustain during the project after making a decision.

## Chapter 6: Earth Moving Template

### 6.1 Introduction

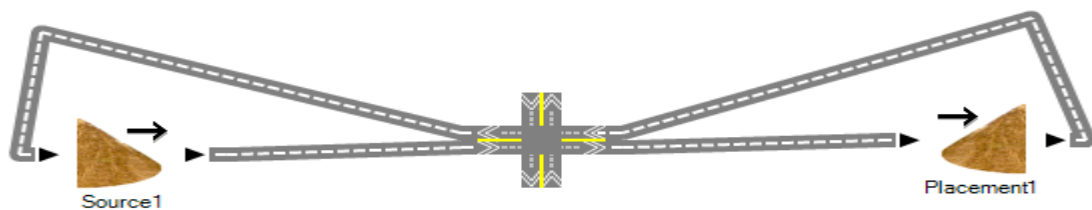
The new earth moving template is a Symphony special purpose template. The advantage of a special purpose template is that it can easily model different scenarios of the earth moving process. Practitioners can build the model and run Monte Carlo without simulation knowledge, as opposed to the general purpose template. The new earth moving template has 6 elements: source, placement, road, intersection 3way, intersection 4way, and cost parameter, as shown in Figure 50.



**Figure 50: New Earth Moving Template Elements**

Compared to the general purpose earth moving template, practitioner usage is simplified by connecting with the database. The template will retrieve the data needed in the simulation automatically. If the practitioners don't have a database,

it can also provide the practitioners an opportunity to manually input the values as they want. The new earth moving template will be more convenient to build the model, as shown in Figure 51. It will not be restricted to only one type of earth moving process, like it would be with the old earth moving template. The template will generate the simulation results of total direct cost, equipment utility, total duration, and the termination data, which can help industry people select equipment types and quantities, do risk analysis, and quickly estimate id price at the bidding stage.



**Figure 51: Sample Model of Earth Moving Operations**

## 6.2 Elements

### 6.2.1 Source Element

The source element is created to represent the conditions and operations of the source site.

The soil profile will be collected in the source element, which includes soil type, related amount and density. Users need to define the soil profiles. The soil should

be excavated and loaded separately. The purpose is to do the reclamation in the earth moving operations. The density is also used to check if the weight of loaded dirt exceeds the truck's payload or not. The truck load cannot exceed its payload. Soil on the top will be excavated and loaded first, and then the other types of soil beneath. There are four types of equipment that can be selected to do the operations, which are excavator/shovel, dozer, loader, and truck. The operations involved in the source site are excavation, preparation, and loading. Sometimes, the preparation is not needed, and sometimes the excavation is not required. In order to make sure that the earth moving template can model different scenarios, different types of operations are created. The operation type is determined by the selected equipment. There are in total 3 types of operations in the source site. If the user selects the excavator and truck, then the operations in the source site are excavate and load. The excavator will be responsible for both excavating and loading. If the user selects the excavator, loader, and truck, the excavator is only responsible for excavating the dirt, then the loader will load the dirt in the trucks. If all types of equipment are selected, then the excavator will excavate the dirt first, the dozer will prepare the excavated dirt into a stockpile, and finally the loader will load the prepared dirt in the trucks. These three types of operations fit most earth moving projects. Users have two options to input the equipment properties: manually and using a database. Table 20 shows the general inputs for the source element. Table 21 and Figure 52 show the contents of equipment

collections. The earth moving template can only support one source site element in the model at one time.

Soil Profile	- Soil type (Top soil, Muskeg, Secondary)
	- Amount (m <sup>3</sup> )
	- Density (kg/m <sup>3</sup> )
Equipment	- Collection (Excavator/Shovel, Dozer, Loader, Truck)
Weather Conditions	- Maximum temperature
	- Minimum temperature
	- Precipitation
	- Maximum Gust
<b>Table 20: General Input of Source Site Element in Earth Moving Template</b>	
Database	- Equipment model
	- Quantity
Manual	(Excavator, dozer, loader) - Capacity (m <sup>3</sup> )
	- Production (m <sup>3</sup> /h)

---

- Quantity

- Mean time between breakdown as exponential distribution (h)

- Repair time (h)(constant, stochastic)

- Engine Capacity (hp)

- Crankcase size (gal)

- Mean time between oil changes (h)

- Equipment rent/ownership cost (\$/h)

- Operator wage (\$/h)

- Cost to repair \$(Constant, Stochastic)

---

(Truck) - Capacity (m<sup>3</sup>)

- Quantity

- Mean time between breakdown as exponential distribution (h)

- Repair time (h)(constant, stochastic)

- Engine Capacity (hp)

- Crankcase size (gal)

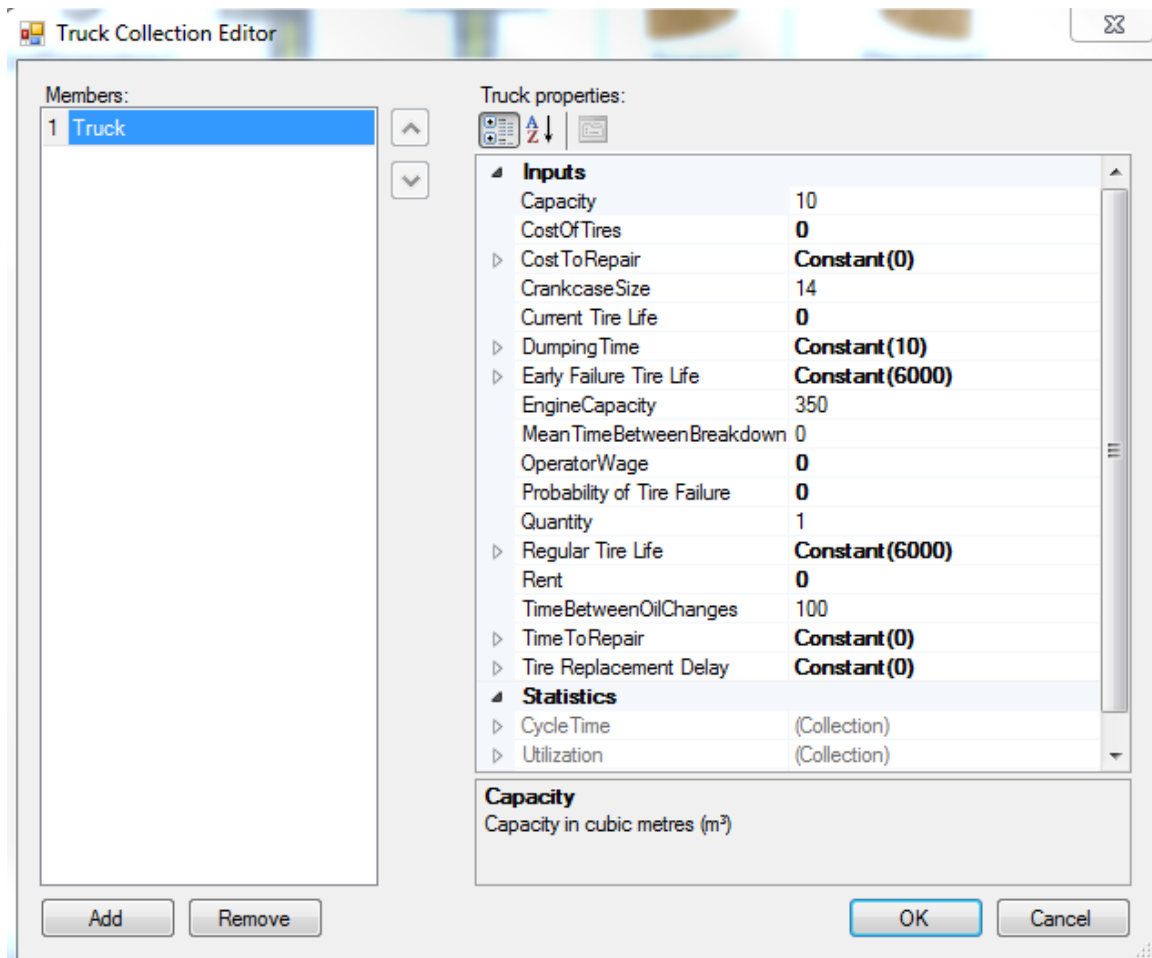
---

- 
- Mean time between oil changes (h)
  
  - Equipment rent/ownership cost (\$/h)
  
  - Operator wage (\$/h)
  
  - Cost to repair \$(Constant, Stochastic)
  
  - Tire cost (\$)
  
  - Probability of tire early break (%)
  
  - Tire life as a probability distribution (h)
  
  - Life time of early break tires as a probability distribution (h)
  
  - Time to change the tires (h)

---

**Table 21: Collection of Equipment Property in Source Site Element**





**Figure 52: Collection of Truck**

### 6.2.2 Placement Element

The placement element is responsible for receiving the dumped soil, spreading, and compacting. In order to do the reclamation, each placement element should define its capacity. This means that the user needs to define what type of soil can be dumped at the placement and its amount. For integrity, the soil types and the related amounts defined in the placement element must be the same as those in the

source element. The quantities of trucks that can dump at the same time need to be defined. In this element, two types of equipment can be selected and defined: dozer and compactor. If the dozer is selected, then spreading will be done after finishing dumping all the soil. The spreading will be done in the reverse order of dumping, which means the soil from the bottom will be spread first, then the soil on the top. If compactors are selected as well, then the soil will be compacted after spreading all the soil. All the inputs in the placement element are listed in Table 22.

General Input	-Soil Types
	- Quantity
	- Number of Trucks Dump Simultaneously
	- Operations (Dump, Spread, Compact)
Equipment	- Collection
Weather Condition	- Maximum temperature
	- Minimum temperature
	- Precipitation
	- Maximum Gust

**Table 22: Input of Placement Element**

### 6.2.3 Road Element

The road element is a connection between the source element and the placement element. It represents the hauling and returning path of the trucks. The road element can have multiple segments with different lengths, rolling resistant, and grade. The hauling and returning speed can be determined by a formula based on the load, grade, and rolling resistance. The inputs are shown in Table 23.

---

General Input	- Segment name
	- Grade
	- RR
	- Length
Weather Conditions	- Maximum temperature
	- Minimum temperature
	- Precipitation
	- Maximum Gust

---

**Table 23: Input of Road Element**

### 6.2.4 Intersection Element

The intersection element is used to model the random traffic flows at specific locations that cause delays to hauling and returning. A traffic light or 4-way stop sign can be modeled. The inputs of the intersection element are shown in Table 24.

---

General Input	- Traffic sign
	- Coming traffic interval (Stochastic)
	- Time pass the Intersection (s)

---

**Table 24: Input of Intersection Element**

### 6.2.5 Cost Parameter Element

The cost parameter element is used to collect the unit cost of lubrication, fuel, and other oils, which are used to calculate the operational cost of equipment. The output of this element will generate a total direct cost combining ownership cost, labor cost, and operational cost. Table 25 below lists the input of the cost parameter element

---

General Input	- Fuel cost (\$/gal)
	- Lubrication oil cost (\$/gal)

---

---

- Other oils and grease (\$/h)

---

**Table 25: Input in Cost Parameter Element**

### **6.3 Inputs and Algorithm**

The production values of the excavator, dozer, loader, and compactor can be constant or stochastic. For real situations, a lot of uncertainties can affect the production rate of equipment. The stochastic values can include these risks, which is also the art of Monte Carlo simulation. By collecting and analyzing the historical data, the production values of equipment can be fitted to a certain distribution. During simulation, a random number between 0 and 1 will be generated first, and then mapped to the distribution to get a specific value for calculation. This is the general method of doing simulation in the old earth moving template.

In the new earth moving template, another method can be adopted. Neural network is a good approach when some main factors are identified as affecting the production. As discussed in Chapter 5, when sufficient required data are collected, the artificial neural networks for predicting the production and speed can be developed and used in the earth moving template. The generated value will be closer to the real project conditions than stochastic distribution, and it will be helpful in analyzing the effects of risks on the whole project duration and cost.

There are also some rules in the algorithm of the new earth moving template:

1. When loading, one truck is only paired with one excavator or loader. The earth moving template will not support two or more excavators loading the same truck.
2. The dozer can only start spreading the dirt after all of the dirt is dumped.
3. The compaction starts after all of the dirt is spread.
4. When tires are worn out or fail early, the truck will stop working, and start changing tires.
5. If the excavator, dozer, loader, and truck are selected in the source site element, the dozer starts preparing the dirt when the excavated soil exceeds its capacity. The loader starts loading the truck when the prepared soil exceeds its capacity.
6. If the excavator, loader, and truck are selected in the source site element, the loader starts loading the truck when the excavated soil exceeds its capacity.

## **Chapter 7: Conclusion and Recommendation**

### **7.1 Conclusion**

The research objective of this thesis is to develop a decision support system for earth moving planning at the bidding stage. Considering the working environment and equipment performance, earth moving projects are full of uncertainties. Good planning can help prevent duration or cost overrun. However, good planning of earth moving projects is not just selecting the most suitable equipment combinations. Risk analysis is also very important in project planning at the bidding stage.

A decision support system was developed to help construction companies assess risks in earth moving operations systematically instead of relying on engineers' experience and intuition. The decision support system is comprised of three components which interact with each other. The first component is identifying the risks and collecting related data for further analysis, which is discussed at the beginning of Chapter 4. The second component is further analysis of the main risks identified in the first component by developing and training an artificial neural network. The data collected in the first component can be used to train the neural network in the second component. In Chapter 4, three potential risks are discussed in detail, which are inclement weather conditions, tire early failure, and haul road conditions. The neural networks for risk analysis are developed, but they are restricted by the lack of training data sets. The third component in the

decision support system is risk analysis of the whole project, which is discussed in Chapter 5 through a case study. The Symphony general purpose template is used to model the earth moving process and do the Monte Carlo simulation. The project completion probability can be calculated according to the statistics of simulation results. The input values can be collected from either the data sets in the first component or the predicted values of the neural networks developed in the second component. The new earth moving template, which is more convenient for industry practitioners to use than the general purpose template, is introduced in Chapter 6.

To conclude, the research objective in this thesis was primarily achieved. However, due to the lack of data and some technical issues, there are still some issues that have not been solved in the thesis. Some recommendations will be provided for further research.

## **7.2 Recommendations**

The main tools in the decision support system are neural networks and Symphony GPT/SPT. The neural networks developed for analyzing the effects of haul road conditions and weather conditions are in the conceptual state. If earth moving companies are willing to provide some assistance, further research could be done to complete training these neural network and connect with the simulation model to provide better estimations and do further analysis of each risk on the whole



project duration and cost. The optimized haul road maintenance methods could be achieved by simulation.

The new earth moving template can be upgraded to be more functional. Further research on the earth moving template could make it support multi-placement and multi-source in the model. It could make the earth moving template model more different scenarios, and the simulation model can be more close to the real situations. In addition, the earth moving template can be used to select and optimize the hauling routines as well.

### References

- AbouRizk, S. M., and Hajjar, D. (1998). "A framework for applying simulation in construction." *Canadian Journal of Civil Engineering*, 25(3), 604-617.
- AbouRizk, S. M., Shi, J. S., McCabe, B., and Hajjar, D. (1995). "Automating the process of building simulation models." *Proceedings of the 1995 Winter Simulation Conference*, 1032-1038.
- Alkass, S., and Harris, F. (1988). "Expert system for earth moving equipment selection in road construction." *Journal of Construction Engineering and Management*, ASCE, 114(3), 426-440
- Bazzazi, A. A., Osanloo, M., and Karimi, B. (2011). "A new fuzzy multi criteria decision making model for open pit mines equipment selection." *Asia-Pacific Journal of Operational Research*, 28(3), 279-300.
- Caterpillar Performance Handbook, 29<sup>th</sup> edition, 1998.
- El-Moslmani, K., Alkass, S., and Al-Hussein, M. (2002). "A computer module for multi-loaders-multi-trucks fleet selection for earth moving projects." *Annual Conference of the Canadian Society for Civil Engineering*.
- Edwards, P., and Bowen, P. (1998). "Risk and risk management in construction in construction: a review and future directions for research." *Engineering Construction and Architectural Management*, 5, 339-349.

- Fayyad, S. (2012). "Modeling reclamation earthwork operations using special purpose simulation tool." University of Alberta, Edmonton, Alberta.
- Haidar, A., Naoum, S., Howes, R., and Tah, J. (1999). "Genetic algorithms application and testing for equipment selection." *Journal of Construction Engineering and Management*, ASCE, 125(1), 32-38
- Hajjar, D., AbouRizk, S. M., and Mather, K. (1998). "Intergrating neural networks with special purpose simulation.
- Hajjar, D., and AbouRizk, S. M. (1999). "Symphony: An environment for building special purpose construction simulation tools." *Proceedings of the 1999 Winter Simulation Conference*, 998-1006.
- Halpin, D. W. (1977). "CYCLONE – A Method for Modeling Job Site Processes." *Journal of the Construction Division*, ASCE, 103(3), 489-499.
- Halpin, D. W. (1990). "MicroCYCLONE User's Manual." Division of Construction Engineering and Management, Purdue University, West Lafayette, Indiana.
- Kartam, N. (1996). "Neural network-spreadsheet intergration for earth-moving operations." *Microcomputers in Civil Engineering*, 11, 283-288.

- Kang, S., and Seo, J. (2013). "GIS method for haul road layout planning in large earthmoving projects: framework and analysis." *Journal of Construction Engineering and Management*, 139(2), 236-246.
- Katz, R. W. (1985). "Probabilistic models." *Probability, statistics, and decision making in the atmospheric sciences*. A.H. Murphy and R.W. Katz, eds., Westview Press, Boulder, Colo, 261-285.
- Kavvas, M. L., Aksit, A. A., and Tulanay, Y. K. (1977). "A first order nonhomogeneous Markov chain for the daily rainfall occurrences in Ankara." *Proceedings of Symposium On Modeling Hydrology Process*, Water Resources Publications, July, 44-59.
- Kirmanli, C., and Ercelebi, S. G. (2009). "An expert system for hydraulic excavator and truck selection in surface mining." *The Southern African Institute of Mining and Metallurgy*.
- Lashgari, A., Yazdani, A. R., and Sayadi, A. R. (2010). "Methods for equipment selection in surface mining; review." *The 1<sup>st</sup> International Applied Geological Congress*, Department of Geology, Islamic Azad University – Mashad Branch, Iran, April, 26-28.
- Latham, M. (1994). "Constructing the team." *HSMO London*.

- Liu, C., and Ming, L. (2013). "Simulation and optimization of temporary road network in mass earthmoving projects." In Proceeding of 2013 Winter Simulation Conference, 3181-3190.
- Ming, L., AbouRizk, S.M., and Hermann, U.H. (2001). "Sensitivity analysis of neural network in spool fabrication productivity studies." Journal of Computing in Civil Engineering, ASCE, 15(4), 299-308.
- Marzouk, M., and Moselhi, O. (2002). "Selecting earth moving equipment fleets using genetic algorithm." In proceedings of 2002 Winter Simulation Conference, 1789-1796.
- Marzouk, M., and Moselhi, O. (2003). "Object0oriented simulation model for earth moving operations." Journal of Construction Engineering and Management, ASCE, 129(2), 173-181.
- Marzouk, M., and Moselhi, O. (2004). "Mutiojective optimization of earth moving operations." Journal of Construction Engineering and Management, ASCE, 130(1), 105-113.
- Matalas, N. C. (1967). "Mathematical assessment of synthetic hydrology." Water Resources Research, 3(4), 937-945.
- Mather, K. R. (1998). "A CAD-based simulation modeling methodology for construction." University of Alberta, Edmonton, Alberta.

- Metropolis, N., and Ulam, S. (1949). "The monte carlo method." *Journal of the American Statistical Association*, 44(247), 335-341.
- Morgan, W. C., and Peterson, L. L. (1968). "Determining shovel-truck productivity." *Mining Engineering*, December, 76-80.
- Morley, D. (2013). "New quantitative methods for planning earthwork operations." University of Albert, Edmonton, Alberta.
- NeuroShell. (1991). Ward Systems Group, Inc., Frederick, Maryland.
- Oloufa, A. A. (1993). "Modeling operational activities in objective-oriented simulation." *Journal of Computing in Civil Engineering*, 7(1), 94-106.
- Richardson, C. (1981). "Stochastic simulation of daily precipitation, temperature, and solar radiation." *Water Resources Research*, 17(1), 182-190.
- Saaty, T.L. (1980). "The analytic hierarchy process." McGraw-Hill, London.
- Shapira, A., and Goldenberg, M. (2005). "AHP-based equipment selection model for construction projects." *Journal of Construction Engineering and Management*, ASCE, 131(12), 1263-1273
- Shi, J. S., and AbouRizk, S. M. (1994). "A resource-based simulation approach with application in earth moving/strip mining." *Proceedings of the 1994 Winter Simulation Conference*, 1124-1129.

- Smith, G. R., and Hancher, D. E. (1989). "Estimating precipitation impacts for scheduling." *Journal of Construction Engineering and Management*, ASCE, 115(4), 552-566.
- Smith, S. D. (1999). "Earth moving productivity estimation using linear regression techniques." *Journal of Construction Engineering and Management*, ASCE, 125(3), 133-141.
- Tannant, D. D., and Regensburg, B. (2010). "Guidelines for mine haul road design." School of Mining and Petroleum Engineering, Department of Civil and Environment Engineering, University of Alberta.
- Taroun, A. (2013). "Towards a better modeling and assessment of construction risk: insight from a literature review." *International Journal of Project Management*, 32, 101-115.
- Thompson, R. J., and Visser, A. T. (2003). "Mine haul road maintenance management system." *Journal of the South African Institute of Mining and Metallurgy*, June, 303-312.
- Tu, J. V. (1996). "Advantages and disadvantages of using artificial neural networks versus logistic regression for predicting medical outcomes." *Journal of Clinical Epidemiology*, 49(11), 1225-1231.

- Wales, R. J. (1994). "Incorporating weather effects in project simulation."  
University of Alberta, Edmonton, Alberta.
- Warren, L. H., Valentin, R. K., and Yves, L. (2011). "Model and algorithms to improve earthwork operations in road design using mixed integer linear programming." *European Journal of Operational Research*, 215, 470-480.
- Xu, J. F., AbouRizk, S. M., and Fraser, C. (2003). "Integrated three-dimensional computer-aided design and discrete-event simulation models." *Canadian Journal of Civil Engineering*, 30, 449-459.
- Yevjevich, V. (1972). "Structural analysis of hydrologic time series." *Hydrol. Pap.* 56., 59 pp., Colo. State Univ., Fort Collins.