

# A History of Rife's Instruments and Frequencies

Updated 6/4/08

This article from its first writing has been an evolving document according to the new information received. When new information has been obtained we have tried to correct errors regardless of the fact it may change everything that has been previously believed as correct. This article was last updated on 4/11/08. At that time the important information about Dr. Rife's Colin B. Kennedy equipment was added to this paper. At that time all the information about super-regeneration was removed because the Kennedy equipment was not super-regenerative equipment but was regenerative equipment. The most significant information that came from the analyzing of the Kennedy equipment was, we now know how Dr. Rife's 1934 instrument worked. The mystery of how his 1934 instrument worked was finally solved! This new updated paper dated 6/4/08 now solves the mystery of how the 1930's Beam Rays Inc. instruments worked. This instrument was first built by Dr. Rife's engineer, Philip Hoyland, late in the fall of 1936. These Beam Rays instruments were used by many doctors and they obtained incredible results. No Beam Rays instrument has ever been found and it has always been believed that Philip Hoyland used audio frequencies in this instrument. The new evidence that we now have shows that the Beam Rays instrument did not use the audio frequencies attributed to it. We obtained a copy of Dr. Gruner's Beam Rays instrument schematic at the 2003 Rife Conference. We gave this schematic to some who tried to figure it out but they made some errors. We gave it to Jim Peters so he could look at it. Because Jim knows old tube technology he was able to easily correct the errors made by others. In this paper we will show how Philip Hoyland's instrument worked. We will also show that the Beam Rays instrument, through an ingenious method, output the same frequencies that the Kennedy equipment and the Rife Ray #4 instruments did. As in the past, when new information about any of Dr. Rife's instruments is obtained this article will be updated at that time. This article dated 6/4/08 takes precedence over all previous dates.

In this article we will examine the way Dr. Rife's instruments worked. We will look at the evidence by quoting the sources such as Dr. Rife, John Crane, John Marsh, Dr. Couche, Dr. Lara, Dr. Stafford and Bertrand L. Comparet (Dr. Rife's attorney in the 1939 Beam Rays Corporation trial, and later John Crane's attorney for Life Labs' trial in 1961). Hopefully anyone who reads this article will have a better understanding about Dr. Rife and the methods he used. Our goal is to try to give people information so that they can make a more informed decision. We have tried to explain in layman's terms so that anyone can understand. We hope this will be helpful.

## What is a ray tube and how does it work?

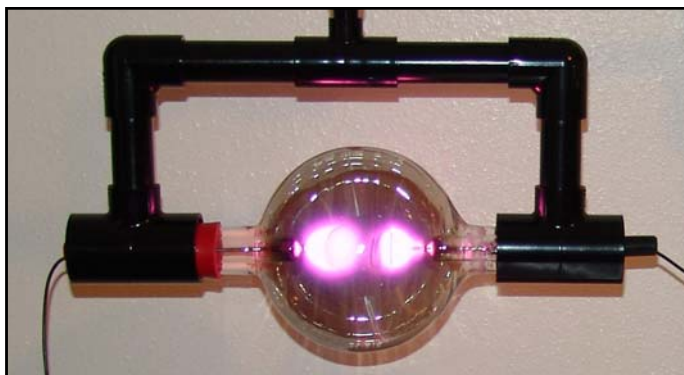

Dr. Rife used a phanotron ray tube with his instruments. A ray tube was made out of glass, quartz or Pyrex and was filled with a noble gas or a mixture of noble gases. Dr. Rife used different mixtures of gases but finally ended up using helium. He stated:

**RIFE:** *"We have experimented with various inert gases and we found that helium stood up by the bombardment better than any of the other gases. That's why we use it. We don't care about the color or anything of that sort. It stood up better over many more hours of bombardment than the argon and the crypton and those different gases that we tried."* (John Marsh Collection, Gonin and Siner Papers, Pages 25 & 26. [www.rife.org](http://www.rife.org))

The ray tube was connected to the instrument by two wires. These wires were connected to two round metal bars that went into the glass tube and they had round disks connected to their ends. One disk was straight and the other one was on a 45 degree angle. This gave it a directional effect towards the patient. Dr. Rife stated that the ray tube was *"a partial directional antenna"*. Because the scientific technology behind ray tubes had already been perfected, Dr. Rife worked with that technology and only had to make some adjustments for it to work the way he wanted it to in his applications. Bertrand L. Comparet, Dr. Rife's attorney, stated in an interview:

**COMPARET:** *"Now, the original instrument had a tube, like an X-ray tube. That was the way in which Rife developed it. You see, all the X-ray work necessarily was done with a beam projected from a tube. So, Rife worked on the same basis."* (Comparet Interview Papers - 1970's)

There are limitations to ray tubes that need to be understood which have to do with the laws of physics. This is a simple explanation but should suffice since we are trying to stay in layman's terms and make it easy to understand. Ray tubes when properly tuned are very efficient. About 95% of the energy that you put into a ray tube comes out but only if the impedance is matched properly. Dr. Rife's #3 instrument put out about 50 watts. This means about 50 watts came out of the ray tube. When it comes to metal antennas and an output of 50 watts you have to divide the 50 watts that come out of the metal antenna by four for every foot that you move away from the antenna in order to take into account the laws of physics on signal loss. The exact power loss in the output of a ray tube is not known, but for our illustration in this article we will use the standard loss with metal antennas as the power loss ratio for a ray tube. Therefore, at one foot away from the ray tube you only have 12.5 watts. At two feet you only have 3.125 watts and at 3 feet you only have about .78 of a watt. The laws of physics are important to understand because Dr. Rife and the doctors that used his equipment put the ray tube within a few inches of the patient's body. Dr. Couche said that he would sometimes touch the body of the patient in the area that needed to be treated. When we discussed this with Dr. Robert P. Stafford, he said that when he treated cancer patients he would put the ray tube within a few inches of the body and treat a 6 inch square area. He would move the ray tube up and down and back and forth so that the whole 6 inch area was treated. He said that he did this because of the way the phanotron ray tube worked. The design of a phanotron ray tube makes it partially directional and concentrates its energy or power into a small area. With the power loss from the ray tube it is easy to understand why Dr. Stafford, Dr. Couch, Dr. Rife and the other doctors used the ray tube right next to the body.

We built both the 1939 Beam Rays instrument (this instrument is not a genuine 1939 Beam Rays instrument as has been believed but is actually a 1940's, less powerful, Verne Thompson variant) and the 1950's AZ-58 ray tube instruments. The AZ-58 (a 1950's Rife instrument made by Life Labs) was built from schematics that are on Stan Truman's site, <http://www.rife.org>, under AZ-58 research information. This instrument is nearly the same as the 1940's instrument built by Verne Thompson. We built the 1940's instrument made by Verne Thompson from schematics found at <http://www.scoon.co.uk/Electrotherapy/Rife/BeamRay/index.htm>. The 1940's instrument uses sine wave audio frequencies and the AZ-58 uses square wave audio frequencies. We tested the AZ-58 and the 1940's Verne Thompson instrument for penetration and found that at about 32 inches from the body full penetration of the carrier frequency emitted from the ray tube was lost. John Crane listed the AZ-58 as outputting 50 watts out of the ray tube but we tested it and found it only puts out 15 watts. The 1940's Verne Thompson instrument only puts out about 15 watts also. The audio frequencies broadcast out of the ray tube from both these machines could only resonate a crystal designed to test resonance through about two inches of tissue. From the tests made, it takes a carrier frequency of at least 0.125

watts to penetrate all the way through the body. It could take an output of 50 watts from a ray tube to resonate a crystal through 14 inches of tissue. These tests showed that it takes more power to penetrate all the way through the body when modulating an audio frequency on a carrier frequency than when a single un-modulated frequency is used. The tests were done using the AZ-58 and the 1940's Verne Thompson machines using a phanotron ray tube outputting 15 watts. Another interesting thing worth noting is when we turned the ray tube more than 45 degrees either to the right or the left of center we could not resonate the crystal. Another test showed we could not resonate the crystal at all on the backside of the phanotron ray tube proving what Dr. Rife said: "The ray tube is a partially directional antenna." One interesting fact worth noting is, Dr. Johnson had in his lab one of the three Rife Ray #4 instruments that were built by Philip Hoyland. It malfunctioned and produced an amazing effect. Dr. Johnson wrote Dr. Gruner a letter dated November 4, 1936 and told him what happened. In that letter, which we will quote from later on in this article, Dr. Johnson mentioned the instrument killed all the organisms in his lab and broke all the quartz glass of a certain shape. This instrument, when it malfunctioned put out many frequencies, perhaps many thousands simultaneously and the power in each frequency would have been so minimal that it makes one wonder how much power it really takes to kill microorganisms. Fractions of a watt would have been all the power that reached these organisms and killed them. It appears from this event that power is important but not as important as having the correct frequency. The crystal we used is not as sensitive as microorganisms.

## **What power levels did Dr. Rife use?**

According to the documents we have, Dr. Rife's #4 instrument and the instrument built by Beam Rays Corporation in the 1930's put out from 50 to 100 watts out of the ray tube. The AZ-58 Life Labs instrument of the 1950's and the Vern Thompson 1940's instrument only output about 15 watts. Because some of Dr. Rife's information about instrument power levels is confusing, most have believed Dr. Rife's instruments put out 400 to 600 watts to the ray tube: however, new information shows this may not be correct. The problem has been that the people who wrote down this information were incorrectly giving the power usage of Dr. Rife's instruments as the output power. Dr. Rife's instruments used 400 to 600 watts but they only output about 50 to 100 watts out of the ray tube. In the paper entitled "*Development of the Rife Ray and use in devitalizing of pathogenic micro-organisms*" it states: "*The frequencies were generated by a tube oscillator with many stages of amplification, the final stage being a 50 watt output tube.*" This part of the description is of his pre-1935 instrument. The output tube was not the ray tube. It appears from the documents that Dr. Rife's pre-1935 instruments did not output any more power than about 50 watts out of the ray tube. He said he lit the tube from another power source then input the frequencies into the ray tube. When Dr. Rife, John Crane and John Marsh were working on sea water conversion - a process that used frequencies - they boosted the output power in the instrument. Concerning that instrument and some 1930's Beam Rays instruments that Dr. Yale had increased the power level on, Dr. Rife said the following:

**RIFE:** "*Now this outfit here - the way we have it boosted up here now with an extreme lot of power behind the actual output that is coming out of the thing...I wouldn't want to use this - or I wouldn't want to use this instrument here the way it is souped up there for this salt water proposition to treat a patient with.*"

**GONIN:** "No."

**RIFE:** "You can get beyond the limit."

**GONIN:** "Yes, quite."

**CRANE:** "That's what Dr. Yale did. You see, he stepped it up and up and up..."

**RIFE:** *“When Verne Thompson used to go down there and take care of Yale’s machines - when he began stepping them up and so...where you get up into that extreme power...oh yes, that is not good. With the power that is in these [50 to 60 watts of power coming out of the ray tube], there is absolutely no harm because I had my microscope here - I had my tube [ray tube] right here in front of it - oh, about 11 or 12 inches away from the slide in the microscope and here I was with this thing all around like that and that tube going here and my specimens and the microscope year after year tuning that thing and it never harmed me any.”* (John Marsh Collection, Gonin Papers, Pages 2 & 3, www.rife.org)

Dr. Yale’s 1936-39 Beam Rays Corporation instruments were putting out a lot more power than Dr. Rife felt was safe. If Dr. Yale’s instruments were changed to put out the maximum power that the main output tube could produce then they may have been putting out around 100 watts out of the ray tube. It may be that Dr. Rife was just overly cautious but his statement should be considered when one starts using power levels of 100 to 300 watts. These power levels are probably not necessary if a phanotron ray tube is used.

## **Is it necessary to use a ray tube to put out the frequencies?**

We really shouldn’t care if an instrument uses a ray tube or a pad as long as it will kill the microorganism we desire. In the strictest sense of the word just because a ray tube is used doesn’t mean it’s “Rife”. By the time you read this whole article you will find out that no one is doing exactly what Dr. Rife did. But does this mean that these instruments don’t work? Those who are building pad instruments are not using ray tubes, and most are not using Dr. Rife’s original frequencies. Those who are building ray tube instruments are also not using Dr. Rife’s original frequencies. We have quite a paradox. This is the problem we face. If we were to build a ray tube instrument that worked exactly the way Dr. Rife’s did and use frequencies from 139,200 to 1,604,000 Hertz then we would be violating FCC regulations and the instruments would be illegal. These ray tube instruments would have to be used with a Faraday cage which is a conducting cage used to stop electromagnetic fields. We can build a pad instrument that will use all the frequencies Dr. Rife used but then we are not using a ray tube. When we consider the legal problems we face today with building instruments, the only instrument we can legally build that would not require a Faraday cage is a pad instrument. This type of instrument could produce all of Dr. Rife’s frequencies. Therefore we should look at this method carefully and not reject it out of personal bias.

As we already said, it really shouldn’t matter if an instrument uses pads or a ray tube as long as it works. With this in mind let’s look at the reasons why pad instruments were built in the first place. John Crane and John Marsh had really good reasons why they built pad instruments. After nearly 50 years of research and use, there is enough evidence that a pad instrument works just as well as a ray tube instrument, as long as there is sufficient power used. In some cases, because of the electrical stimulation like a T.E.N.S. instrument, they may work even better than a ray tube on some conditions. We will now take a look at some of the reasons that prompted John Crane and John Marsh to use pads:

**RIFE:** *“But the principle of this thing is basically built on a coordinative vibration. Just like one tuning fork pitched to the C. Another one here—you strike this one and this one vibrates.”*

**DR. LARA:** *“What kind of vibration is it? Electromagnetic vibration?”*

**RIFE:** *“We won’t say magnetic, we will say electronic frequency vibration. The same as put out on a broadcasting station for the radio. The same thing you know, only it’s transmitted into a tube. And the tube acts as a partial directional antenna you see.”* (John Marsh Rife CDs - CD 6 track 2)

In the John Marsh papers describing his trip to Ohio we read a statement made by Dr. Rife:

**RIFE:** *"You know we had an idea when we had our Clinic in La Jolla, of course that was battery and motor generator operated that set, you know, and boy it would sure raise the devil with all the radios so we had a couple of cars that was equipped with car radios and we sent them out and we would take the switch of that thing, and had a code you know like an S.O.S., and one of them went up north, and one of them went south from La Jolla. Before we started in we wanted to see how far we were going to disturb things with it you know, and incidentally we had it in a steel room, a steel lined vault about this size at the old Ellen Scripp's home. It was the vault in the library of the Scripp's home where they kept their valuable manuscripts and books in all steel lined and a door on it like a safe. We had the thing inside of that too, but it didn't make much difference, but we started in, and one car lost the pick up on top of Torrey Pines, and the other one half ways through Mission Beach picked it up, and then they could go a hundred feet and lose and then they would have to pick it up again. Old Henry [Henry Siner] the boy that was with us out there, one of the lab boys, boy he went up in the air. He says, "By God" he says "look, we're going to fix them up right. At two o'clock we'll hook this up to a big radio station, a big transmitting station, and at two o'clock next week we'll broadcast for tuberculosis, and at half past three the week after we will broadcast for cancer, and everybody at the radio will pick it up". See, boy I said Henry that really is an idea." (John Marsh Collection, Trip to Ohio Papers, Page 7, www.rife.org)*

This last statement made by Dr. Rife was made over 20 years after the 1934 clinic. Dr. Rife new that the frequencies would broadcast from a metal antenna just as well as from a ray tube. The fact that he felt that Henry Siners idea was a good one even after more than 20 years shows that Dr. Rife new a metal antenna would give the same results as a ray tube. It is apparent from what we have read that Dr. Rife believed it was the frequency that was devitalizing the organism and the method of application really didn't matter. He understood that the frequencies could be broadcast by a radio station if it had enough power. Metal antennas are equal to or more, efficient than a ray tube. When John Crane and John Marsh (Dr. Rife's two business partners in the 1950's) came to understand this, they eliminated the ray tube and used pads or hand cylinders to apply the frequencies. The pads and hand cylinders work just like an antenna except you do not want too much power so that they are safe to use. The body also becomes an antenna when you hold the hand cylinders or use the pads and this is why pad instruments work. Bertrand Comparet stated this in his interview:

**COMPARET:** *"Now, Crane said "Well now look, Rife himself admits that no matter how much tube and ray, and so on, you have, you can't get any results unless you've got the right frequency. Therefore the real clue to the thing is the frequency and not the means by which you deliver it." Comparet also said: "Well, Crane originally was, with more modern techniques, duplicating the Rife machine, tube and all for early experiments. And, as I say, he came to the conclusion that you just weren't getting anything additional by the use of the tube. If you didn't get the frequency, you could run the rest of it indefinitely and nothing happened. So, what Crane did, he got an audio frequency generator. Now, you could make them up yourself by an awful lot of work, or you could buy a Heathkit audio frequency generator and get all the same results with a lot less time and effort. So he was using these Heathkit generators. Now, instead of a beam projected from a tube, a ray, he simply had two wires. I think they were aluminum knobs on the end of them, which would be used. They would be put on the body in such a position that the natural flow of the current from one to the other would go through the diseased area, and he got astonishing results." (Comparet Interview Papers - 1970's)*

These pads or hand cylinders act just like an antenna when in contact with the body, but only if you have an RF carrier frequency. This is where John Crane and John Marsh made a critical error and the reason Dr. Rife did not like their pad instrument. Without an RF carrier frequency the audio frequencies will only go through the connective tissue and not the cell. There are exceptions to this and they have to do with the wave form of the frequency. If a square wave audio frequency is used then the higher harmonics produced from this wave form may penetrate the cell to some degree. How much power from these harmonics penetrates the cell is not known. This may explain why instruments that

do not use an RF carrier frequency work to some degree. Dr. Rife expressed his dislike for John Crane and John Marsh's instrument that did not use a carrier frequency when Bertrand Comparet asked him about it:

**COMPARET:** *"And I asked Rife, because I thought Rife would certainly say that the way Crane was working on it then was still using the Rife principle, but he indignantly denied it."* (Comparet interview papers - 1970's)

We know that Dr. Rife knew that a metal antenna would work and we know that the pad instrument worked on this principle. It must have been the fact that it did not use an RF carrier frequency that upset Dr. Rife. Pad instruments that do not use a carrier frequency are limited in power. The highest power output that can be safely used from a non RF carrier pad instrument is 1/5 of one watt (0.20). Any more power than this and the muscles of the body will begin to lock up. If you use an RF carrier frequency then you can output a hundred times more power safely. It is apparent that it was the lack of power that concerned Dr. Rife. All of Dr. Rife's original frequencies, except two, were in the (RF) Radio frequency broadcast band of frequencies. We will cover these frequencies and the audio frequencies along with the importance of a carrier frequency later in this article.

Some people have thought that it was the light from the ray tube that made it work. But the evidence doesn't seem to support that either because in the Gonin Papers of John Marsh, Dr. Rife said this with regard to the light that came from the ray tube:

**RIFE:** *"We don't care about the color or anything of that sort."* (John Marsh Collection, Gonin Papers, Page 25, www.rife.org)

Dr. Couche, while visiting Dr. Rife's lab with some other men, said:

**DR. COUCHE:** *"There was fifteen inches of concrete on the floor so as to stop any earthquake shocks from interfering with his work. And in his laboratory upon the ground floor he had a microscope with a slide on it that this group of people and myself looked at. And this was not stained, there was no killing of the bacteria on it. It was just a fresh culture of the colon bacillus.....Well we all went down under the stairs into the cellar right immediately under the microscope upon the floor above us and the Rife machine was down in underneath there under the culture in the cellar probably I suppose about ten feet away, eight or ten feet away. And he turned the machine on and gave it less than a half minute's frequency for the colon bacillus...Then he turned the machine off and we all came upstairs and waited for ten or fifteen minutes. And presently he came back to his microscope and he said, "Well gentlemen come and look at the slide now." Well to my astonishment the bacilli all had been killed and they were all stacked up on the slide."* (John Marsh Rife CDs - CD 3 track 1)

There is no possible way the light from the ray tube could have penetrated that fifteen inch concrete floor. It is obvious that the light didn't make any difference but that it was the frequencies that were broadcast through the ray tube. It is easy to see that there is more than one way to deliver the frequencies. The ray tube could be easily replaced with metal hand cylinders and foot pads. It is interesting to note here that Dr. Rife said Abrams' Oscilloclast would devitalize the BX cancer virus and it was a contact type device. The wave form the Oscilloclast produced is shown in Dr. Rife's 1936 film. John Crane and John Marsh probably used this contact method because of the success of Abrams' instrument. The Abrams' instrument proved that a contact type device would work and it was used before Dr. Rife even started using a ray tube. In fact Abrams' contact instrument predates all of Dr. Rife's work. Pad instruments like Abrams' instrument came in contact with the body. Abrams instrument worked on the same RF principles as Dr. Rife's instruments. Pad instruments with an RF carrier turn the body into an antenna and work on the same principle as a metal antenna or ray tube. People have been using pad instruments without an RF carrier for almost 45 years now and have had very good re-

sults. But, in order to work the way the ray tube instruments do, an RF carrier frequency is necessary.

## **Are RF frequencies safe to use?**

Today there are many who profess to believe in Dr. Rife and his method of coordinative resonance using frequencies but claim the RF is bad or harmful. Some of these people build and sell instruments that do not use any RF carrier frequencies and put in their sales information that RF frequencies are harmful. A great disservice to Rife. The instruments they build use low audio frequencies that were used in the early 1940's and 1950's instruments (these frequencies will be discussed later).

When it comes to Dr. Rife and the method he used you cannot "have your cake and eat it too." Dr. Rife's principles were all based on coordinative resonance through RF frequencies. Any method used that does not use RF frequencies cannot be called Rife's method. Today, regardless of the method used, people call their instruments "Rife Instruments" no matter how they are built. Dr. Rife specifically asked that his name not be put on any instrument, yet this is exactly what people do. There is nothing wrong with people building non RF instruments, but claiming that RF is bad or unsafe just to sell their instruments is where the problem lies. Dr. Rife's Colin B. Kennedy equipment (which will be discussed later in detail) had a frequency range of 12,000 hertz to about 2,000,000 hertz. With this equipment Dr. Rife found the many frequencies that would eliminate or devitalize the various organisms he tested. In Dr. Rife's tests he would have naturally started in the low frequency range and slowly worked his way higher until he found a frequency that would eliminate the organism. All of the frequencies that he found were in the RF range. They went from 139,200 hertz for Anthrax to 1,604,000 hertz for the BX cancer virus. It was only these frequencies that Dr. Rife found that would resonate the organisms and devitalize them. Since Dr. Rife found that only these RF frequencies would resonate and kill the organism then it is impossible to separate RF from coordinative resonance. It would also be impossible to build an instrument that truly worked on Dr. Rife's principles without the use of RF or radio frequencies. In order to prove the safety of Dr. Rife's work we must quote him since he is the person that everyone believes in. Below are two of his quotes on the safety of using RF frequencies in the range that he used. The first quote comes from a letter sent to Dr. Stein in 1953:

**RIFE:** *"I have operated the frequency instrument since 1921. I have watched it advance in style and performance with the advancement of electronics. In the many years I have used this equipment in my research, I have never suffered an injury or any ill effects whatsoever. I found it reliable in performance and efficient in results."*

On the John Marsh, Rife audio CDs Dr. Rife also made this statement about his RF frequency instrument:

**RIFE:** *"I stood in front of that thing for thirty years finding these different frequencies that devitalize these different bacteria. And that thing [RF ray tube] was shooting on me right here [his chest], but it is absolutely harmless to normal tissue and each individual bacteria requiring a different frequency to devitalize."*

Dr. Milbank Johnson, M.D. also used the instrument for many years and conducted clinics and found the instrument safe to use. Dr. James B. Couche, M.D. used the instrument in his private practice for over 22 years and also said he found the instrument safe to use. Dr. Tully, D.D.S. purchased one of Dr. Couche's instruments and used it for several years and found it completely safe to use. Dr. Robert P. Stafford, M.D. used the frequency instrument for over 5 years and also expressed that he found the instrument completely safe to use. These statements along with Dr. Rife's that we quoted above show that Dr. Rife found that his RF frequencies in the ranges he used were as safe to use as the frequencies output by any radio station. These frequencies are broadcast through the air day and night passing through our homes without any harm to the human body. There may be some people

with RF sensitivity but this does not mean that RF is unsafe to use. This only means that these people are sensitive to RF and should avoid it if they find a problem using it.

## Did Dr. Rife use audio frequencies?

In Dr. Rife's 1961 deposition he revealed the fact that he was using audio frequencies in the beginning of his work with frequency instruments:

**RIFE:** *"Initially I worked with loose couplers to get an audio oscillation and then with the use of transmitters, I tried to balance the audio and modulate the audio on a carrier wave to transmit the audio energy."*

Dr. Rife stated that at the beginning of his work, back in the days when loose couplers were used in generating frequencies, he was also testing audio frequencies which he modulated onto an RF or radio frequency carrier. Below are photos of loose couplers courtesy of "Henry Rogers, Western Historic Radio Museum" ([www.radioblvd.com](http://www.radioblvd.com)). These loose couplers worked by moving one coil inside the other in order to change the frequencies.

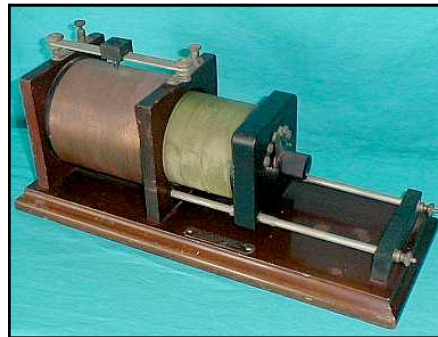
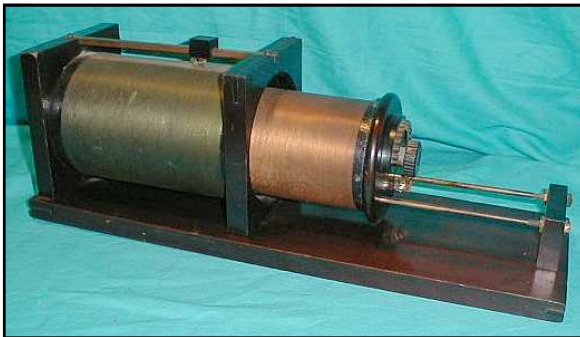

It is apparent that Dr. Rife first tested audio frequencies on organisms in his search for the frequency which would devitalize them. The audio range would be the logical place to start. If he couldn't find a frequency in the audio range, he then moved up into higher frequency ranges until he found a frequency that would devitalize an organism. In Dr. Rife's early lab notes, he listed only two organisms that had an audio frequency M.O.R. Later when Dr. Rife found out that he was reading his frequencies incorrectly, one of those audio frequencies was changed to a much higher RF frequency. There are other statements made by Dr. Rife which show that he tested the audio range. In fact Dr. Rife gave the full range of his frequencies:

**RIFE:** *"Some of them are in the visible band, or I mean not only the visible band but, uh, band of frequencies audible [audio] to the human ear. Some of them are way beyond either way. They run through a very, very large gamut. Some of them are very, very broad, long. Some of them are...not extremely short. There are none of them what we call our ultra short wave that I have found yet. Well there's many of them...we would, uh, classify in the ultrasonic band because they're not visible [sic] with the human ear. They're way beyond you know. And some of them are even in the broadcast band. Your cancer is very high. You can't hear it, the oscillation. But now you take your T.B. [Tuberculosis]. Now that's down. A little more you see...if you don't have an absolute coordinative resonance, you have nothing. One tenth of one meter off and you have nothing. Its got to be absolutely correct for that individual organism. It's got to be precise...the virus of cancer has a certain frequency. And it has to be there, otherwise if it's a little one way or the other, no good, no good for nothing. Infrared will penetrate, yes, but the heat is not the thing because the heat is not the frequency, it's [Infrared] way down in the very low band of frequencies and the laboratory rate of the BX is up into the high band."* (John Marsh Rife CDs - CD 5 track 2, CD 6 track 2, CD 7 track 1 and CD 9 track 1)



In these statements Dr. Rife clearly explains the broad range of his frequencies. Some were audio and could be heard by the human ear; others were in the ultrasonic range, and some were even in the broadcast band. Cancer he said was very high. He states the frequencies have to be very accurate to work. One tenth of one meter off and they would not work at all. We will talk about this it later.

Following here are two additional statements that also verify that Dr. Rife's instruments could output a modulated audio frequency:

**RIFE:** *"You know we had an idea when we had our [1934] Clinic in La Jolla, of course that was battery and motor generator operated that set, you know, and boy it would sure raise the devil with all the radios so we had a couple of cars that was equipped with car radios and we sent them out and we would take the switch of that thing, and had a code you know like an S.O.S., and one of them went up north, and one of them went south from La Jolla. Before we started in we wanted to see how far we were going to disturb things"* (John Marsh Collection, Trip to Ohio Papers, Page 7, www.rife.org)

In order to be able to put out an S.O.S. type signal he would have had to modulate the audio frequency onto a carrier in order for the car radios to pick up the signal. This audio frequency would also create a problem with radio stations. On the John Marsh Collection of Dr. Rife's audio CDs, Dr. Couche makes an interesting comment about the #3 instrument. He was present at the 1934 clinic sponsored by Dr. Johnson and the University of Southern California. He stated:

**DR. COUCHE:** *"They gave him a treatment of the Rife frequencies which are in the auditory band."* (John Marsh Rife CDs - CD 3 track 1)

The cancer and tuberculosis frequencies used in the 1934 clinic were not audio frequencies. Why would Dr. Couche make this statement? The evidence shows that Dr. Couche was getting things mixed up. The Beam Rays instruments which Dr. Couche used for over 22 years used audio frequencies. Dr. Couche purchased three of these instruments and used them until 1952 when he retired. We will cover this instrument later in this paper. Everything which we have quoted shows that the equipment from 1934 and earlier could output audio frequencies and that Dr. Rife tested audio frequencies right from the beginning of his work in 1920.

Although we have been able to prove that Dr. Rife tested the audio range of frequencies (as any good scientist would have done), it should be pointed out that by 1935 when the Rife Ray #4 was built, he no longer felt that he needed to test audio frequencies any longer. This is indicated by the fact that no audio oscillator was included in this new frequency instrument. The Rife Ray #4 will be discussed later in this article.

## **History of Dr. Rife's instruments and changes made**

There is finally enough information to know exactly what Dr. Rife did in the early years, from 1923 to about 1934. This is because we now know exactly what instruments he used and their output ranges. His lab notes detailing 26 conditions and their frequencies have also been preserved. The earliest information, which we now know is incorrect, indicated that he used frequencies ranging from the audio range to just over 17 MHz. We now know Dr. Rife's frequency instrument did not have this frequency range and that he misread his frequencies. And, we also know that he used many different frequencies at this time.

We now understand the operation of the Rife Ray #3 and Rife Ray #4 along with the instruments that used only audio frequencies which were built in the 1940's and 1950's by Verne Thompson. The Beam Rays Corporation instrument of 1936-39 built by Philip Hoyland is now understood thanks to Jim Peters who corrected the Beam Rays schematics. What was once thought to be an original Beam Rays instrument we now know is not one, and in fact, was actually built by Verne Thompson in the 1940's. We now know that the audio frequencies that were used in the instruments built in the 1940's

by Verne Thompson are not the frequencies used by Philip Hoyland's 1936-1939 Beam Rays Corporation instruments. In the Beam Rays Trial of 1939 Philip Hoyland said Dr. Rife's frequencies were in the upper bands (139,000 to 1,604,000 Hertz) inferring that his frequencies were in the lower bands. We now know from testing the circuit of the Beam Rays instrument that Philip Hoyland was not being truthful in this statement. The frequencies taken off of the 1940's Verne Thompson instrument went from 1200 to 21275 Hertz. These frequencies which have been attributed to Philip Hoyland have been referred to as the 10X audio frequencies and will be discussed in more detail later in this article. These frequencies were taken off the 1940's instrument using an oscilloscope. The 1950's instrument used by Dr. Rife, John Crane and John Marsh was built and updated from the 1940's instrument built by Verne Thompson and was called the AZ-58. Today it has been rebuilt from schematics. The frequencies used in it are even lower than the 1940's audio frequencies. The frequencies used in the AZ-58 went from 120 to 2128 Hertz. The correlation between the 1940's instrument and the 1950's AZ-58 instruments will also be discussed in greater detail in this article. In order to follow the evolution of Dr. Rife's technology, we will first examine the Rife Ray #3 (built prior to 1934), then his next instrument, the Rife Ray #4 (built by Philip Hoyland in 1935), then the ray tube instrument (built by Beam Rays Corporation 1936-39), then the AZ-58 ray tube and pad instruments (built by Life Labs in the 1950's).

## 1934 Rife Ray #3 instrument used in the 1934 clinic

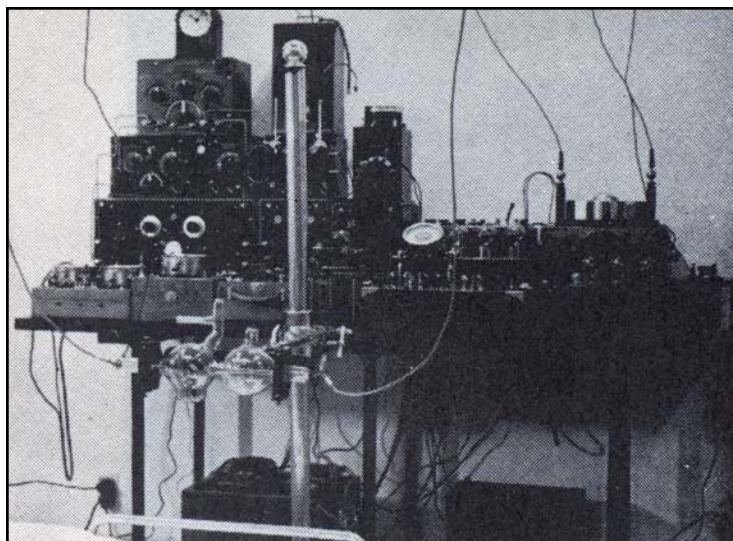

- 1) This was a regenerative instrument that used a ray tube.
- 2) It consisted of two Kennedy Regenerative Receivers (the model numbers were 110 and 281). These two receivers made it possible to have a combination of one low frequency oscillator and one high frequency oscillator or two high frequency oscillators.
- 3) The output was sine wave.
- 4) Power usage was from batteries. Output to the ray tube was about 50 RF watts?

This instrument was used in the 1934 clinic by Dr. Milbank Johnson. If you look at the bottom of the photo you can see part of the bed railing and mattress where they treated the patients. If you look at the table you can see that the instrument was not a one piece instrument but had many components. This instrument has always been considered the best instrument used by Dr. Rife because it produced the results of the 1934 cancer and tuberculosis clinic. Those interested in the work of Dr. Rife have always wanted to know how this instrument worked. They have also wondered what equipment he used. This has been one of the biggest Rife mysteries. There has been all kinds of speculation on how his first instrument worked. What was its waveform? What was the frequency range? Could it generate audio frequencies? Was it super-regenerative (as he wrote on his lab notes), or was it just regenerative? All of these things have remained mysteries for over fifty years. It was generally believed that the 1934 instrument was custom made for Dr. Rife. However, if the equipment had not been custom made, the mystery would be over. And today, thanks to some great detective work done by James Peters, the mystery, in fact, is now over. The instruments were not custom made. They were standard off-the-shelf frequency generating equipment that Dr. Rife purchased. The equipment and frequency ranges are now known.

A better photo of the equipment Dr. Rife used appears on the top right of page 12. He most likely stacked it all up on a table and took a picture of it after he started to use the newer equipment built for him in 1935. This photo, amongst others, made it possible to figure out the equipment Dr. Rife used. This photo has been provided courtesy of the Rife Research Group of Canada. Here in this paper you will be able to see the actual equipment along with the selling advertisements of the 1920s that give the specifications of the equipment.

We will now look at each piece of equipment and take an in-depth look at the specifications of each. All pieces of equipment except the ray tubes and possibly the five stage amplifier were considered off-the-shelf equipment. This means that this was standard frequency generation equipment which could be purchased from companies in the 1920's. Although they are regenerative receivers, they could output whatever frequency Dr. Rife wanted to use when the regenerative circuit was turned up. Dr. Rife used top-of-the-line Kennedy equipment from the Colin B. Kennedy Company, which built some of the most accurate, high quality equipment that could be purchased in 1923. It was also some

of the most expensive equipment to purchase. We will now take a look at the photo below on the left. It is one of several photos of Dr. Rife's lab instruments. The bottom two pieces of equipment were the Kennedy Receiver Model 110 connected to the Kennedy Two-Stage Audio Amplifier Model 525. The other piece of equipment sitting on top of the Kennedy Receiver Model 110 we will look at later. Below this lab photo is a better photo of this old antique equipment. To the right of these photos is the 1923 advertisement from the Colin B. Kennedy Company which provides the frequency range and features of this regenerative receiver. It also gives the effective frequency range from 175 to 25,000 meters or from 12,000 Hertz to 1,700,000 Hertz.

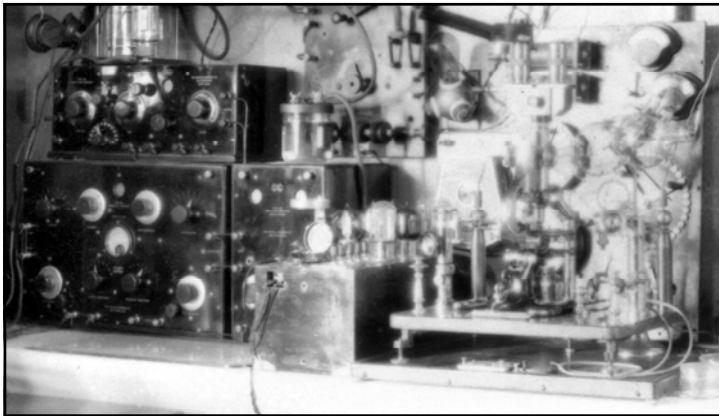
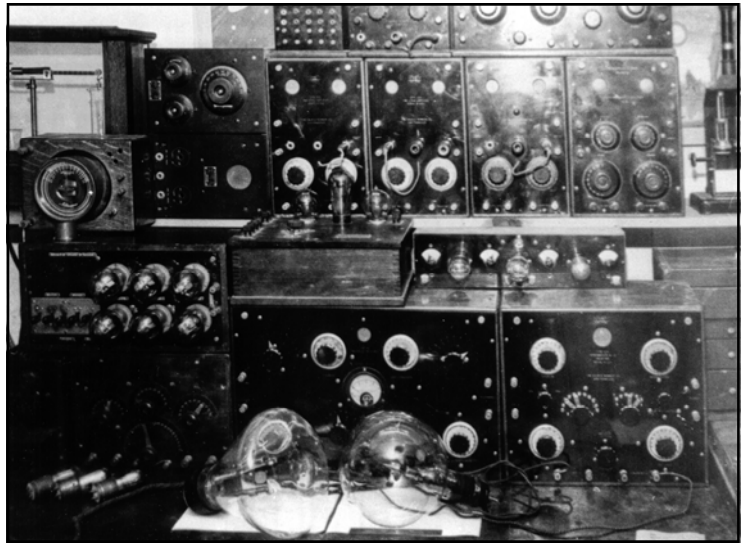

This instrument could actually go from 150 meters to 25,000 meters giving it a range from 12,000 to 2,000,000 Hertz. The Kennedy Company was just being conservative in its advertisement. The next instrument that is on top of the Receiver Model 110 in the lab photo is the Kennedy Short-Wave Regenerative Receiver Model 281. And on the top left of page 13 is a photo of the Kennedy Receiver Model 281 and to the right is the Kennedy advertisement. This instrument had an effective range from 185 meters to 620 meters or from 483,000 Hertz to 1,620,000 Hertz. This instrument could actually go from 150 meters to 620 meters giving it a range from 483,000 to 2,000,000 Hertz. Kennedy Company again being conservative. In the photo, on the top of this page, that had all of Dr. Rife's equipment was another Kennedy Regenerative Receiver, this being the Kennedy Model 220. A photo of it is on page 13 below the Kennedy Model 281 photo with the Kennedy Company advertisement for it on the right. Its effective frequency range was from 175 meters to 3250 meters or from 92,000 Hertz to 1,700,000

**KENNEDY  
EQUIPMENT**

# ANNOUNCING

**THE NEW KENNEDY UNIVERSAL REGENERATIVE  
RECEIVER**  
TYPE 110  
**EFFECTIVE RANGE: 175 TO 25,000 METERS**

DETECTS  
REGENERATES  
OSCILLATES  
On all wave  
lengths in  
common use.

Licensed  
under  
Armstrong  
U. S.  
Patent  
No. 1,113,149

**Surpassing even our highest hopes when we undertook its development, this latest addition to the Kennedy line is of interest to everyone who uses a radio receiving set.**

Our engineering staff spent many months in developing this unit and released it for production only when its performance surpassed every requirement we had set for it. By our long specialization in receiving equipment we have built up a reputation which is so precious that we can afford to put the Kennedy trade-mark on only the highest quality product.

We have spared no effort to make this the best receiver on the market. We honestly believe that it is.

**These are some of its features:**

- Variable inductive coupling between primary and secondary.
- Extremely sharp tuning because of very efficient inductance units.
- Special Kennedy bank-wound moisture-proof inductors.
- Generous overlap between inductance steps.
- Large balanced primary and secondary variable condensers.
- Micrometer adjustment of secondary condenser
- Variable grid condenser with air dielectric, permitting most effective use of all types of available receiving tubes.
- Adjustable feed-back circuit.
- Fine adjustment of plate voltage by means of potentiometer connected between terminals of filament battery.
- Weston ammeter for measuring filament current.
- Bus-bar type insulated wiring.

*Further details in Bulletin 101, mailed on request.*

Ask your dealer for a demonstration. Compare the performance of this receiver with any other you have ever seen. The users of Kennedy Equipment are our best advertisers.

**THE COLIN B. KENNEDY COMPANY**  
INCORPORATED

RIALTO BUILDING SAN FRANCISCO



Hertz. It could also go from 150 meters to 3250 meters, which gives it a true range from 92,000 to 2,000,000 Hertz.

Now that we have all the frequency generating equipment identified we can now come to some conclusions. All of this Kennedy equipment was sine wave. Square wave was not used or even generated in this old equipment. The Kennedy Receiver Model 110 had a frequency range from 12,000 to 2,000,000 Hertz or 2 MHz. This shows that Dr. Rife's instruments had the ability to output audio frequencies, a fact that he mentioned in his 1961 deposition. The only audio frequencies he would have used would have been modulated from this equipment. Dr. Rife also mentioned in his 1961 deposition that he balanced the audio on a carrier which would have been a modulated waveform.

What is really surprising is the fact that none of the Kennedy equipment that Dr. Rife used could output a frequency higher than about 2 Megahertz (MHz). This fact changes a lot of things with regard to his lab notes dated before 1934. It was impossible for him to produce 11,780,000 Hertz or 17,033,000 Hertz using this equipment. These are the two frequencies that Dr. Rife listed on his lab notes for the BX cancer virus. The frequency range of the Kennedy equipment now explains why Dr. Rife's Engineer, Philip Hoyland, said that Dr. Rife had misread his frequencies prior to 1935.

With Dr. Rife's approval, Philip Hoyland was hired by Dr. Milbank Johnson, M.D. and the University of Southern California Special Medical Research Committee in 1935 to build a more up to date portable frequency instrument to be used for their research. Dr. Rife's 1934 instrument was cumbersome because it was not just one, but several, pieces of equipment which were difficult to move and use. In order to build the new instrument, Philip Hoyland needed to know what frequencies Dr. Rife was using. So he brought to Dr. Rife's lab an oscillator to read the frequencies. It was difficult to read the correct frequencies prior to this time unless you were very proficient at doing it. Philip Hoyland had to know exactly what frequencies Dr. Rife was using in order to build the new instrument. While testify-

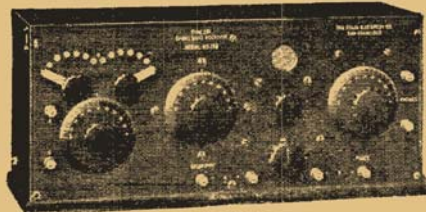

**KENNEDY  
EQUIPMENT**  
Our new improved  
Type 281  
**SHORT-WAVE  
REGENERATIVE  
RECEIVER**

is designed for high efficiency  
on wave lengths of 185 to 620  
meters. The ideal set for relay work. It embodies all the features of correct design  
and superior workmanship that have established the reputation of Kennedy Equipment.

You will be interested in the details of this new short wave set. Ask your dealer  
about it. If he cannot supply you we will send you Bulletin 201 on request.

The high quality of Kennedy apparatus is being appreciated by those who want  
the best results. We again find it necessary to greatly increase our factory capacity  
to meet the demand.

**THE COLIN B. KENNEDY COMPANY**  
INCORPORATED  
RIALTO BUILDING SAN FRANCISCO

**Announcing**

the new  
**KENNEDY**  
**Intermediate-Wave  
Regenerative Receiver**  
Type 220

Range 175 to 3250 Meters  
We believe there is no other receiver on  
the market which represents so much concentrated  
quality value.

See it at your dealer's. Examine it thoroughly,  
have a demonstration and form your own opinion.  
We don't ask you to accept ours.

Licensed under Armstrong U. S. Patent No. 1,113,149  
Bulletin 201, giving full details mailed on request  
**Ask Your Dealer**

**THE COLIN B. KENNEDY COMPANY**  
INCORPORATED  
RIALTO BUILDING SAN FRANCISCO

ing on the stand in the 1939 Beam Rays trial, Philip Hoyland stated this about how he obtained the frequencies: (Beam Rays Trial Papers [www.rife.org](http://www.rife.org))

**HOYLAND:** *"They were taken off the last machine [the Kennedy equipment] that was built by Dr. Rife. I transferred them from one machine to another."*

At another point during the trial the transcript reads as follows:

**COMPARET:** *"In June of 1935 was when you made an agreement with the [transcript missing words] medical research to build a Rife Ray machine, [the Rife Ray #4] you did build it soon after that?"*

**HOYLAND:** *"Yes."*

**COMPARET:** *"You had an agreement with them that all work was to be done under Dr. Rife's direction?"*

**HOYLAND:** *"That's what the contract called for."*

**COMPARET:** *"Did you do this work without getting the frequencies from Dr. Rife?"*

**HOYLAND:** *"I calibrated the machine according to the bacteria."*

**COMPARET:** *"What specifically did you do that constituted this recalibration?"*

**HOYLAND:** *"I used a standard oscillator against his machine to see what frequencies he was using."*

**COMPARET:** *"He set his machine and you measured his frequencies?"*

**HOYLAND:** *"Yes."*

**COMPARET:** *"Did you make any memorandum of these particular frequencies?"*

**HOYLAND:** *"Yes, I gave Dr. Johnson and Dr. Rife a list of them."*

Later during the trial Dr. Rife was asked where the frequencies came from:

**JUDGE KELLY:** *"When you constructed this Beam Ray machine [from Kennedy equipment] you had a dial representing the frequencies or harmonics?"*

**RIFE:** *"We had many dials on the original machine [Kennedy Model 110]."*

**JUDGE KELLY:** *"Is that the machine Mr. Hoyland got the frequencies from?"*

**RIFE:** *"Yes, he took them off that old machine [Kennedy Model 110]."*

From the court testimony given by Dr. Rife and Philip Hoyland we see the frequencies were read by Philip Hoyland off of the Kennedy Model 110 and 281 and used in the next instrument which was the Rife Ray #4 (We will be discussing this instrument next). Now let's continue on reading the court testimony:

**COMPARET:** *"Now going back to your assumption that Dr. Rife knew the frequencies, had Mr. Hoyland ever told you that Dr. Rife knew them?"*

**EDWARDS:** *"No, he told me that Dr. Rife only thought he had them."*

**COMPARET:** *"What did you think that meant?"*

**EDWARDS:** *"Well, Mr. Hoyland told me about that time [1934 and before], that Dr. Rife measured the frequencies only by the length of the wire and that he did not take other factors into consideration."*

Here in the court testimony we just read that Dr. Rife had not read the frequencies correctly when he measured them. This would have been a mistake easy to make in the 1920's and 1930's. The frequencies which Philip Hoyland read off of Dr. Rife's #3 instrument, which consisted of the Kennedy equipment, were different from the earlier lab note frequencies recorded by Dr. Rife. This has caused a lot of confusion because the frequencies that Philip Hoyland read were all lower than 2,000,000 Hertz. Dr. Rife had written down in his lab notes frequencies as high as 11,780,000 and 17,033,000 Hertz for the BX cancer virus. However, the Kennedy Models 110, 220 and 281 could not output these high frequencies. It is apparent that Philip Hoyland was absolutely correct when he said in court that Dr. Rife had misread his frequencies. Also, Philip Hoyland testified in court that he gave both Dr. Rife and Dr. Johnson a list of the correct frequencies he read off of the Kennedy Model 110. This verifies the truth of what Philip Hoyland said in court.

There is another verification that Dr. Rife had misread his frequencies. On the Rife audio CDs, Henry Siner, Dr. Rife's lab assistant, read from a lab note of the BX cancer virus. All the information was the same as Dr. Rife's earlier pre-1934 lab notes except the frequencies. On that corrected lab note Henry Siner read 187 meters for the wave length and 1,604,000 Hertz for the cycles per second frequency for the BX cancer virus. Both the meter frequency and the cycles per second frequency were the same frequency. However, on the pre-1934 lab note, both were different. One frequency was 11,780,000 and the other was 17.6 meters or 17,033,000 Hertz. This also verifies that Dr. Rife had not read his frequencies correctly. The frequency of 1,604,000 Hertz was the frequency Philip Hoyland read and gave to Dr. Rife and Dr. Johnson and it was used in the new instrument built in 1935 called the Rife Ray #4.

There is one thing we need to consider. Dr. Rife could have read a harmonic of the frequency instead of the correct frequency. It appears this is in fact what Dr. Rife did. Dr. Rife understood how easy it was to read a harmonic frequency instead of the correct frequency and recognized that he may not have had true fundamental frequencies. He stated:

**RIFE:** *"I've talked to you [John Crane] and Verne [Verne Thompson] and other people too that there may be some of the frequencies that we are using that may be harmonics, you know...It's not an impossibility that some of those frequencies may be a harmonic. We may not know the true frequencies of some of them. But it does the business. Maybe if we had the true frequency it would do it better because it has more power than a harmonic." (John Marsh Rife CDs - CD 7 track 2)*

The frequency that Philip Hoyland read off of Dr. Rife's 1934 instrument was 1,604,000 Hertz. Dr. Rife had written two frequencies down on his pre-1934 lab notes. One was 11,780,000 Hertz and the other was 17,033,000 Hertz. The seventh harmonic of 1,604,000 is 11,228,000 which is close to the 11,780,000 especially if you consider that Dr. Rife was not reading his frequencies correctly. We now know Dr. Rife was not even reading the harmonic correctly. Now the eleventh harmonic of 1,604,000 is 17,644,000 which is close also to 17,033,000 Hertz. Had Dr. Rife read the frequencies correctly then both the meter frequency and the cycles per second frequency should have been the same. This was the case in the new lab note when it was corrected by Dr. Rife and read by Henry Siner in the 1950's. The evidence is absolutely overwhelming that Dr. Rife was not reading his frequencies correctly because the frequencies Philip Hoyland read were used in the next instrument which was called the Rife Ray #4.

We wondered where these harmonics that Dr. Rife read might of come from. Did the Kennedy Model 110 have harmonics in its waveform? Did it output a sine wave waveform? Was the waveform

distorted? The only way to answer these questions was to find a working Kennedy 110 and put it on a spectrum analyzer. Jason Ringas of the Rife Research Group of Canada and I contacted Henry Rogers the owner of the Western Historic Radio Museum ([www.radioblvd.com](http://www.radioblvd.com)) who owns two Kennedy 110s that are still operational. Henry Rogers knew nothing about Dr. Rife but agreed to let me come visit his location to check the readings of the Kennedy Model 110. He also owns a Kennedy 220 and a Kennedy Model 281, both of which are also in working condition. The Kennedy Company built top-of-the-line equipment and we were surprised to find out even after over 80 years, they still worked as well as they did when they were new. Very little attention is ever needed to get these instruments back in working condition because of the quality of their construction. So with spectrum analyzer in hand, I went to see Henry Rogers and we put the Kennedy 110 on the spectrum analyzer to get the answers to our questions. Below is the reading of the waveform of the Kennedy Model 110 at 417,000 Hertz using a PicoScope 3205 spectrum analyzer. On the left is the waveform which proves that Dr. Rife was using

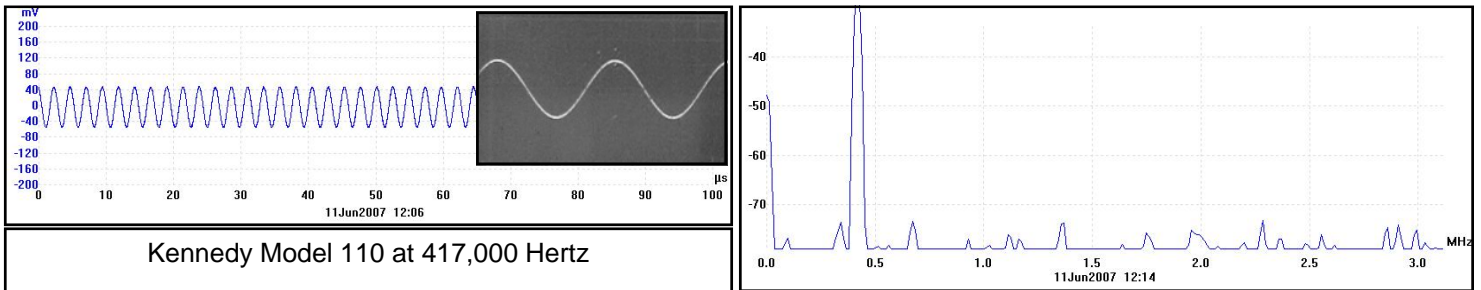

sine wave. That question is finally answered. The spectrum analyzing of the frequency revealed that there were no harmonics in the waveform. The noise which shows up as little spikes are from the power supply. These old receivers ran on batteries and when they are hooked up to batteries the noise in the circuit is greatly reduced. The amazing thing about the Kennedy Model 110 sine wave waveform was that it was picture perfect. This amazed us because everyone believed that the equipment that Dr. Rife used would have had a distorted waveform. No one that I have ever talked with believed that this old equipment was capable of producing a nearly-perfect waveform. It was as good as we can do today with our sophisticated modern frequency generating equipment. The fact that it produced no harmonics also totally amazed us. Below are the readings of the Kennedy Model 110 at 770,000 and

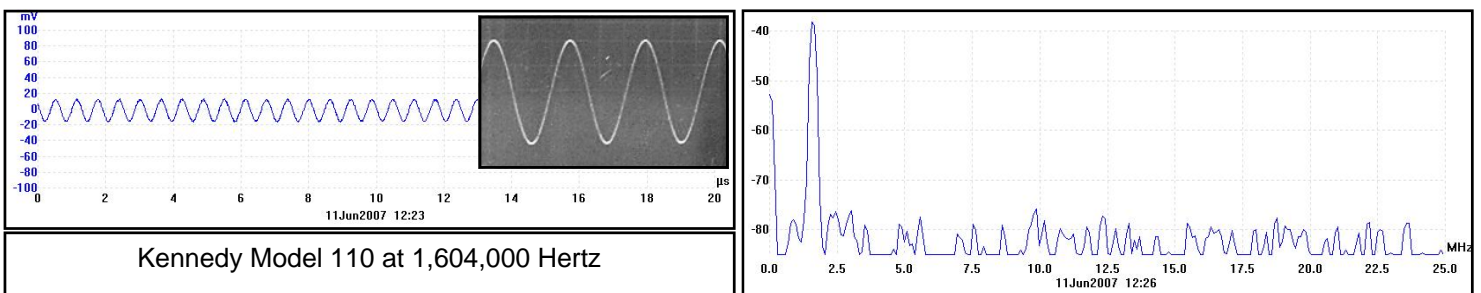
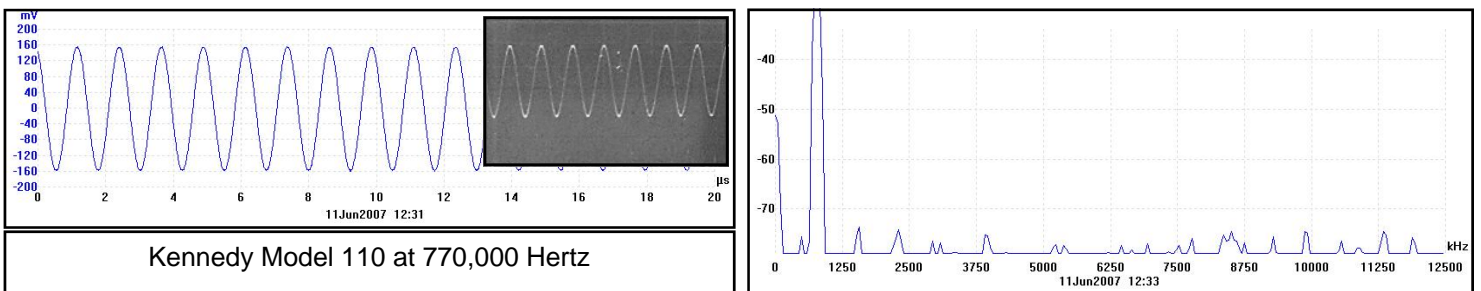

1,604,000 Hertz. At 1,604,000 Hertz the sine wave was still nearly perfect and it did not produce any harmonics. We checked all frequencies out to 50 Megahertz for harmonics and found none.

This testing showed that Dr. Rife's equipment output a sine wave waveform with no harmonics. So where did the frequencies come from that Dr. Rife read and recorded on his old lab notes? Why did he record two frequencies in his lab notes? We now knew what equipment he used. His pre-1934 lab



notes just didn't make any sense. We knew from Henry Siner's reading of the corrected BX lab note that the meter frequency and the cycles per second frequency should be the same. It is apparent that Dr. Rife used two different pieces of equipment to read his frequencies. One piece of equipment gave a reading in meters and the other piece of equipment gave a reading in cycles per second. However even knowing this did not explain where the harmonics came from.

We knew that the noble gas he used in his ray tube could double the frequency that went through it. These types of tests have been done with plasma in laboratories in the past. So we decided to make some tests. We tested the Icom 718 which we hooked up to a phanotron ray tube. This is the type of ray tube Dr. Rife used and is the only one we tested. We first tested to see what the sine wave looked like coming out of the Icom 718. We wanted to make sure that it did not produce any harmonics, and in fact, our testing showed it did not produce any harmonics. Then we hooked it up to the antenna tuner to see if the tuner distorted the waveform and produced any harmonics. We found it did not distort the wave form or produce harmonics through the antenna tuner except at 1,604,000 Hertz. This is only because the Icom is not supposed to output a frequency below 2,000,000 Hertz. Below this frequency it will produce two harmonics (see graph on page 18). The other two frequencies we tested were 11,780,000 and 17,033,000 Hertz. These were the frequencies Dr. Rife recorded on his pre-1934 lab notes and neither of these produced harmonics through the antenna tuner. Then we put it through the ray tube. The ray tube didn't just double the frequency - it also produced all the harmonics that Dr. Rife would have read. We now had the answers as to where the harmonics came from. The ray tube produces the harmonics. You can put a harmonic-free sine wave through a ray tube and get all the harmonics that Dr. Rife recorded in his lab notes. On the next three pages are the readings taken in this testing.

# Testing done with PicoScope 3205 spectrum analyzer at 1,604,000 Hertz using Icom 718

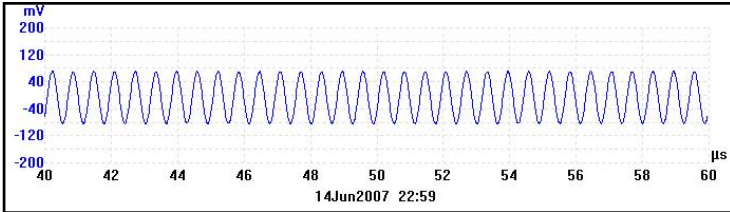

Sine wave out of Icom 718 at 1,604,000 Hertz.

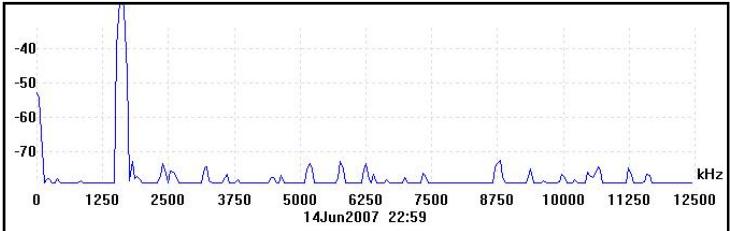

Icom 718 at 1,604,000 Hertz measured with spectrum analyzer showing no harmonics.

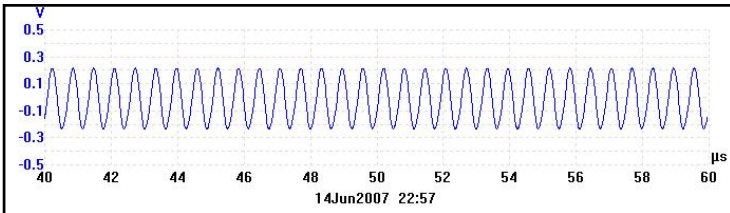

Sine wave out of Icom 718 at 1,604,000 Hertz using the antenna tuner.

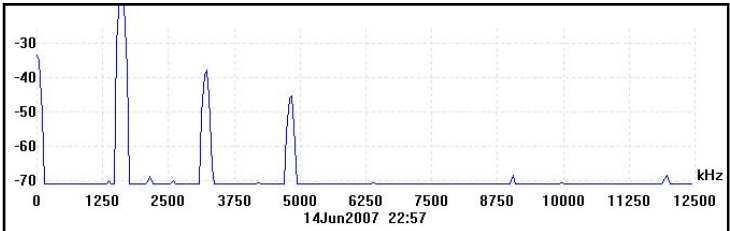

Icom 718 and antenna tuner at 1,604,000 Hertz measured with spectrum analyzer showing two harmonics. These two harmonics are only produced because the Icom is not designed to go below 2,000,000 Hertz. If you output 2,000,000 Hertz it produces no harmonics.

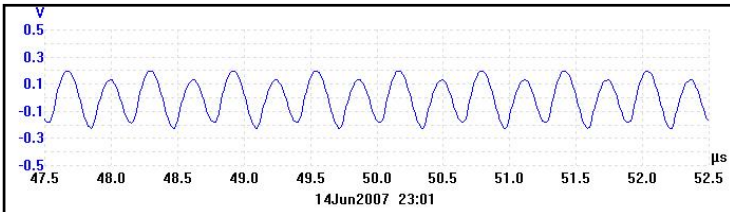

Sine wave out of Icom 718 at 1,604,000 Hertz using antenna tuner and ray tube. Sine wave is distorted. In all tests done the sine wave was always distorted when put through a ray tube.

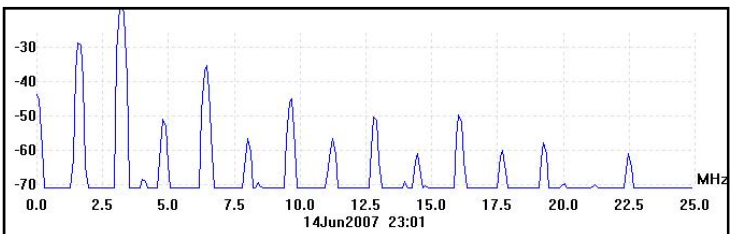

Icom 718 at 1,604,000 Hertz using antenna tuner and ray tube. Measured with spectrum analyzer showing harmonics all the way up to 22,000,000 Hertz. This shows that Dr. Rife's Kennedy Model 110 which only had a top range of 2,000,000 Hertz did produce harmonic frequencies in the 11,000,000 and 17,000,000 hertz range.

Below are the measurements taken with the PicoScope 3205 spectrum analyzer from the Icom 718 using the antenna tuner and ray tube at 11,780,000 Hertz. This was the first frequency Dr. Rife listed on his pre-1934 lab notes which was later changed to 1,604,000 Hertz.

Testing done with PicoScope 3205 spectrum analyzer at 11,780,000 hertz using Icom 718

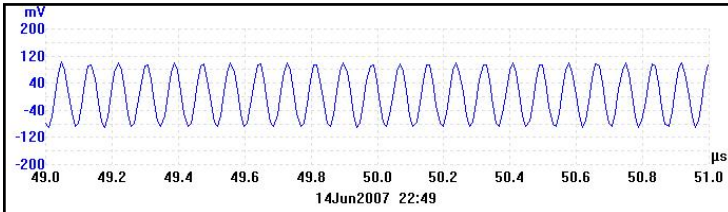

Sine wave out of Icom 718 at 11,780,000 Hertz.

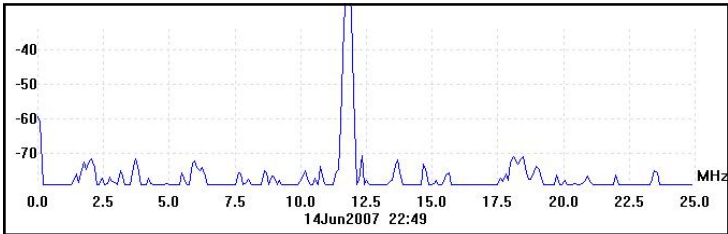

Icom 718 at 11,780,000 Hertz measured with spectrum analyzer showing no harmonics.

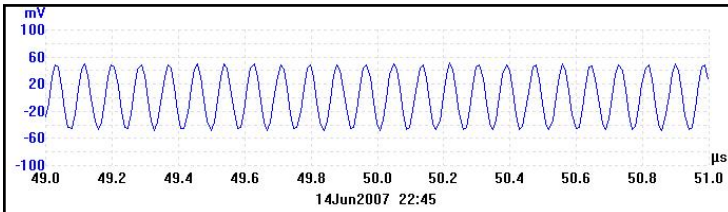

Sine wave out of Icom 718 at 11,780,000 Hertz using the antenna tuner.

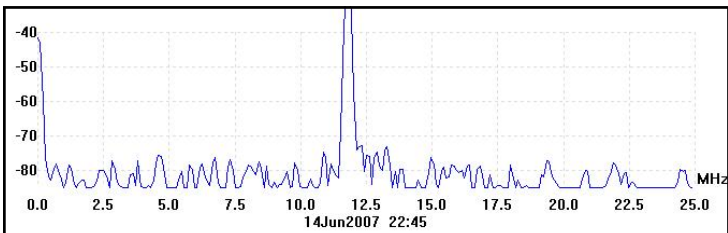

Icom 718 and antenna tuner at 11,780,000 Hertz measured with spectrum analyzer showing no harmonics.

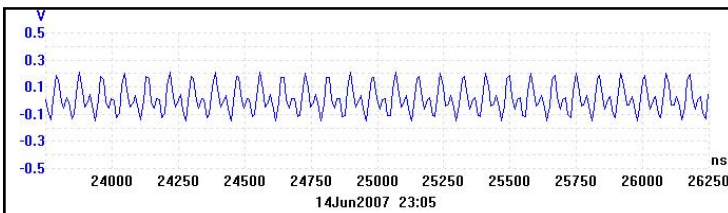

Sine wave out of Icom 718 at 11,780,000 Hertz using antenna tuner and ray tube. The sine wave does not look like a sine wave. In all cases the sine wave is distorted to some degree when put through a ray tube.

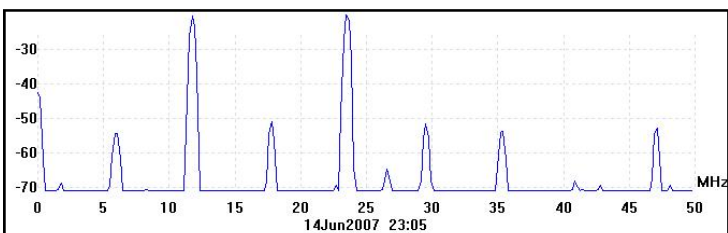

Icom 718 at 11,780,000 Hertz using antenna tuner and ray tube. Measured with spectrum analyzer showing harmonics all the way up to 50 MHz.

Below are the measurements taken with the PicoScope 3205 spectrum analyzer from the Icom 718 using the antenna tuner and ray tube at 17,033,000 Hertz. This was the second frequency on his pre-1934 lab notes which was recorded in meters. This was later changed to 187 meters which would give us a frequency of about 1,604,000 Hertz. This confirms that Dr. Rife was just reading a harmonic at 17,033,000.

Testing done with PicoScope 3205 spectrum analyzer at 17,033,000 hertz using Icom 718

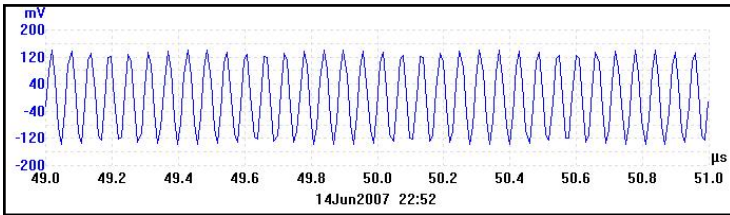

Sine wave out of Icom 718 at 17,033,000 Hertz. Some distortion was in the sine wave.

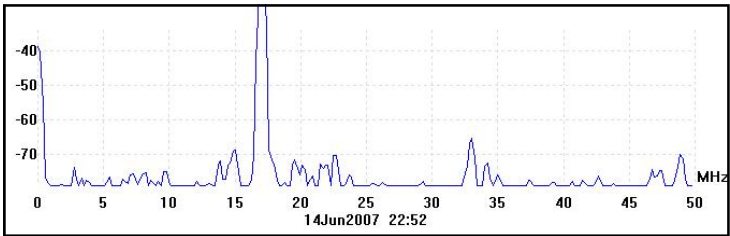

Icom 718 at 17,033,000 Hertz measured to 50 MHz with spectrum analyzer showing no harmonics.

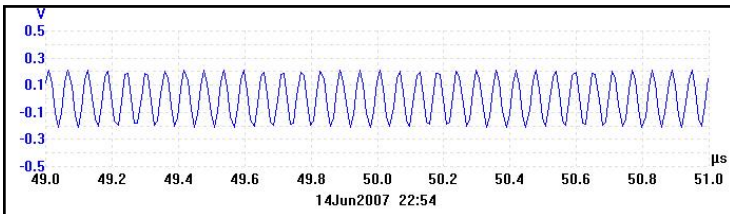

Sine wave out of Icom 718 at 17,033,000 Hertz using the antenna tuner. Same slight distortion noticed.

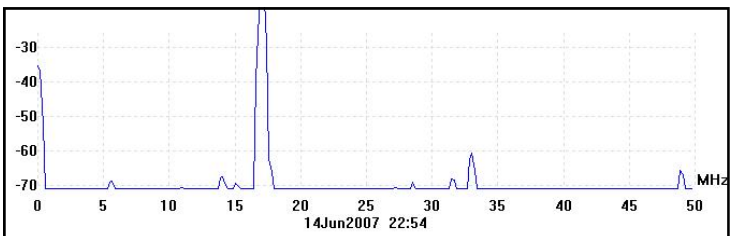

Icom 718 and antenna tuner at 17,033,000 Hertz measured to 50 MHz with spectrum analyzer showing no harmonics.

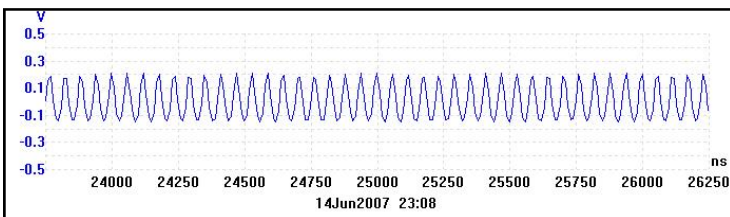

Sine wave out of Icom 718 at 17,033,000 Hertz using antenna tuner and ray tube. Sine wave was distorted even more when put through a ray tube.

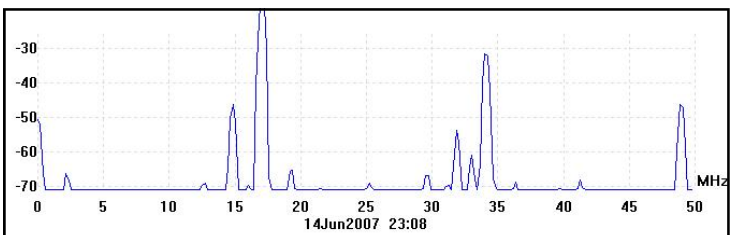

Icom 718 at 17,033,000 Hertz using antenna tuner and ray tube. Measured with spectrum analyzer showing harmonics all the way up to 50 MHz.

Westinghouse RC Receiver & Amp



Western Electric Audio Amplifier 7A



Kennedy Model 281 Receiver



Photo of Rife's equipment that he used in his lab for doing M.O.R. work.

Five stage 50 watt class A cascade RF amplifier

The three photos of Rife's lab on this page are courtesy of the Rife Research Group of Canada.

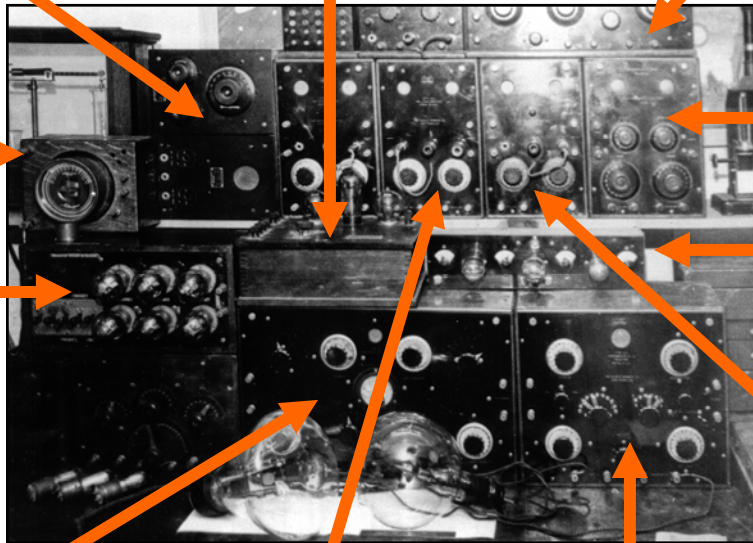

Kennedy RF Amplifier

Remler 700 I.F. Amplifier 3.5 MHz



Kennedy Model 110 and 525 Audio Amplifier



Kennedy Model 220 and 525 Audio Amplifier

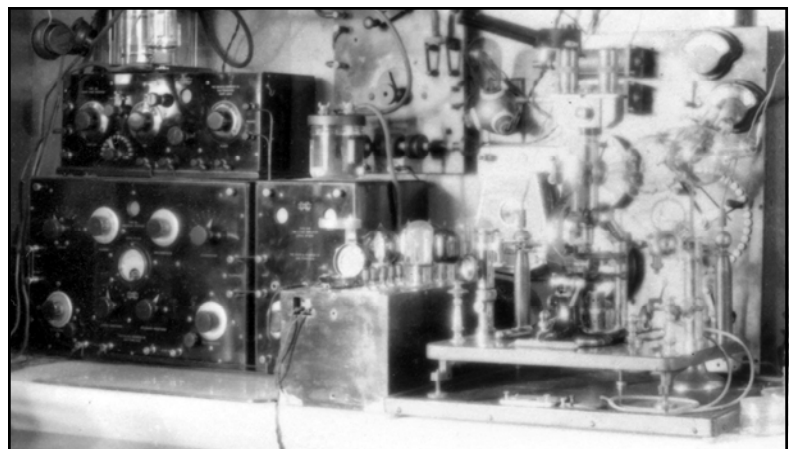
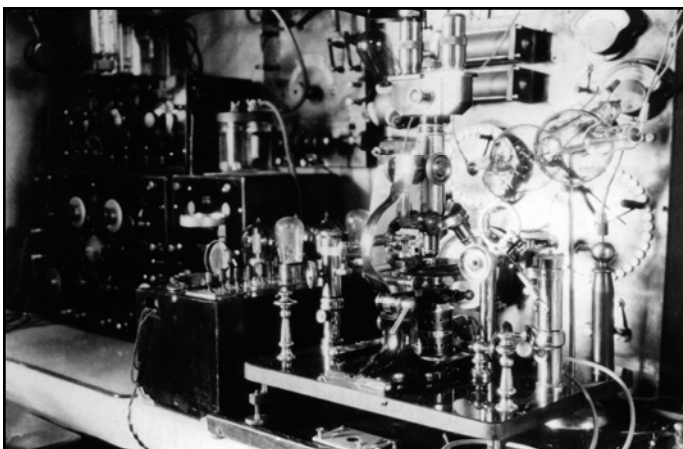

Kennedy Model 110, 281 and 525 Audio Amplifier Set Up In Rife's Lab For Doing M.O.R Work

After having done all this spectrum analysis testing we now know how Dr. Rife misread his frequencies. The ray tube gave him the harmonics that he read. Also, he evidently did not read the harmonics correctly. Philip Hoyland read the frequencies correctly because he was an electronics engineer and had the ability to read the frequencies properly. We wish to mention that we do not feel this in any way diminishes or questions the brilliance of Dr. Rife. Even Dr. Rife himself said he was not an electronics man and never claimed to be one. He made a mistake that any untrained person could have easily made.

Having said this, let's move on to the facts. Philip Hoyland read 1,604,000 Hertz for the frequency of the BX cancer virus. Dr. Rife corrected his lab notes to this frequency. This frequency was used in the later Rife Ray #4 instrument. With these documented facts, we now know what must have happened. Dr. Rife read the seventh harmonic of 1,604,000 Hertz and recorded it on his pre-1934 lab notes. The only problem was he was unable to read the seventh harmonic correctly and misread it as 11,780,000 Hertz. It should have been 11,228,000 Hertz because this is the actual harmonic frequency that came out of the ray tube. Dr. Rife had two different pieces of equipment for reading frequencies - one which read in cycles per second and the other which read in meters. These types of meters to measure wavelengths were common electronic equipment, just as digital frequency counters are in common use today. Wavelength meters were much harder to use and measure frequencies with if you don't really understand how to use them. We know that this was the case. Dr. Rife then misread the eleventh harmonic of 1,604,000 Hertz. This harmonic should have been 17,644,000 Hertz instead of the 17,033,000 Hertz. Again, we know from the corrected lab note read by Henry Siner that the cycles per second and meters frequencies should match. In these early pre-1934 lab notes none of the cycles per second and meter frequencies matched. This shows he used two different pieces of equipment to read the frequencies. The final fact is the Kennedy Company equipment could only output frequencies to 2,000,000 Hertz (far below the 11 and 17 MHz range).

When we read the Kennedy Model 110 the instrument was surprisingly accurate. Dr. Rife could have very easily hit the frequency he wanted within the tolerances he gave. He gave "one tenth of one meter" as a gage to show how close you had to be to an organism's M.O.R. At 1,604,000 Hertz this would be about 850 Hertz. He said if you were off by this amount the frequency wouldn't work. With that in mind it would be necessary to be within a few hundred Hertz of the BX M.O.R. in order to make sure the frequency was effective. The Kennedy instrument could hit within 200 to 300 Hertz very easily at 1,604,000 Hertz. After changing the dials and then coming back to the same dial settings you could get within 2000 to 6000 Hertz at 417,000 Hertz. This is less than 1% inaccuracy which is quite amazing. Even Philip Hoyland, when he measured the frequencies rounded off all but one frequency to the nearest thousandth. The testing of the Kennedy Model 110 shows that the frequency for the BX is most likely somewhere between 1,600,000 and 1,608,000 Hertz, however it could be as much as 10,000 Hertz plus or minus of 1,604,000 Hertz. All of the frequencies are only close and this should be considered when using them. One fact that helps to point this out is Philip Hoyland read 1,604,000 Hertz for the frequency of the BX. He also gave 187 meters as the frequency. One hundred and eighty seven meters is 1,603,168 Hertz. This is a difference of 832 Hertz and shows why the frequencies are only close. Today's frequency generating equipment is very accurate at hitting a specific frequency but in Dr. Rife's era this was not the case. Dr. Rife's microscope gave him an advantage that we do not have. He could see the organism die.

So now that we know that Dr. Rife's Kennedy Model 110, 220 and 281 only went to 2,000,000 Hertz with harmonics going to about 20,000,000 Hertz (see graph below). We have to ask this question: What frequency is really the true M.O.R? Is it the 1,604,000 Hertz or a harmonic of it? The ac-

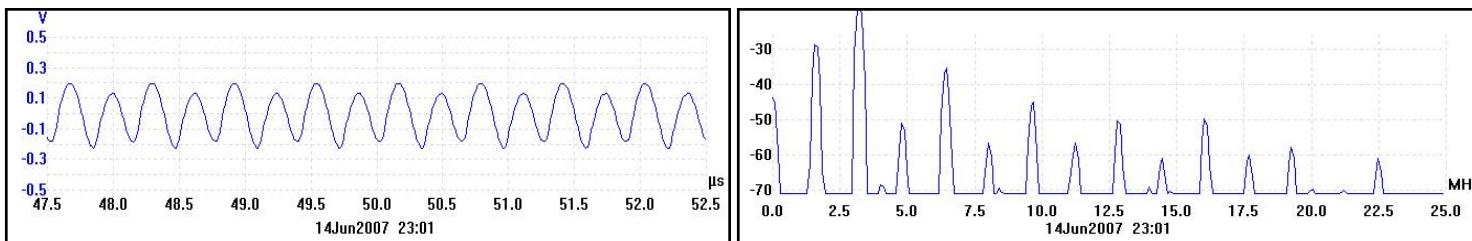

tual M.O.R. frequency could have been very easily a harmonic, and Dr. Rife would have never known it. The below spectrum analyzer graph of 1,604,000 Hertz shows it could be any one of these harmonics. Since the ray tube is what produces these harmonics it may be very important to have all these harmonics. Myth Busters, a cable television program did a test to see if they could break a crystal glass with sound waves. They found when they used only the fundamental frequency without the harmonics they could not break the glass. But when they used the harmonics along with the fundamental frequency then they were able to break the glass. This may or may not be pertinent but it is something that should be considered.

With this in mind we decided to see if there was a way that we could duplicate the harmonics without having to use a ray tube. The below reading with the spectrum analyzer below showed that if we distorted the sine wave no more than what the ray tube did we could produce the same harmonics as a ray tube. The reading was done at 1,604,000 Hertz taken from a GB-4000 Function Generator without amplifier. This test showed it was very easy to duplicate the harmonics produced by a ray tube. We decided to test a triangle wave since the distorted sine wave out of the ray tube resembled it. It also produced the same harmonics as a ray tube.

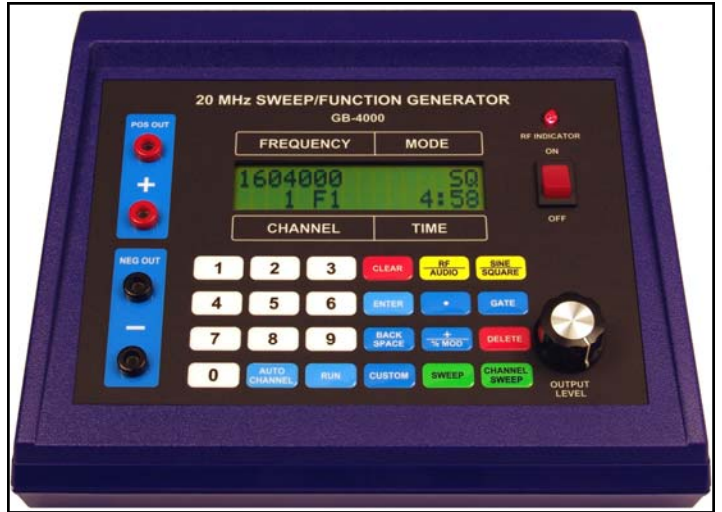

GB-4000 20 MHz Sweep Function Generator. Instrument used for the tests.

### GB-4000 at 1,604,000 hertz using PicoScope 3205 Spectrum Analyzer

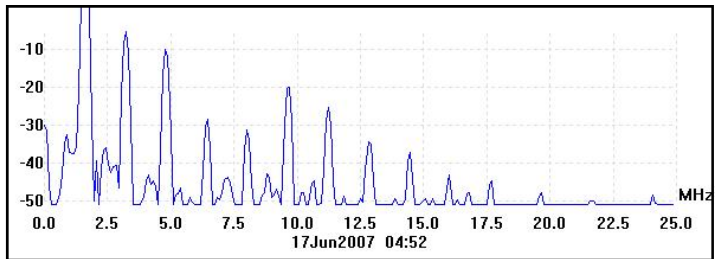
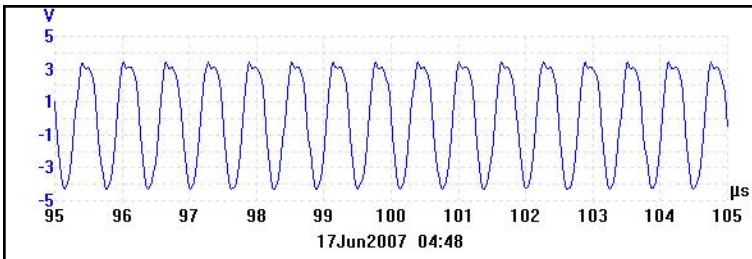



We will now discuss Dr. Rife's tuning of the Kennedy Receiver Model 110 using headphones. In the photo above, on the left, you can see a set of headphones on the Model 525 audio amplifier. Headphones were used to tune the Kennedy Receiver Model 110 and Dr. Rife's earlier instrument that he used before purchasing the Kennedy equipment. When Dr. Rife first tested the audio range of frequencies he would tune his instrument using headphones. Bertrand Comperet, Rife's attorney for the Beam Rays trial of 1939 made this statement when he was interviewed by Dr. John Hubbard:

**COMPERET:** *"Way back in the old days, way, way back, Rife told me that the way he used to tune his instrument, which in those primitive days was, I guess, garbled. He would hook up headphones and turn the thing. He had a very keen musical sense of pitch and so on, and he would tune it in his headphones until he got the right pitch, and that was the frequency."* (Comperet Interview Papers - 1970's)

The headphones were used for tuning the audio frequencies in Dr. Rife's early tests when he used loose couplers. The headphones also played an important role in the tuning of the Kennedy Receivers. In the second photo, above on the right, you can see the regeneration dial of the Kennedy Receiver Model 110. When you turned up the regeneration you would listen for clicks or some static in the headphones, this would tell you that the instrument was oscillating. If you turned the regeneration up too high you would hear feedback in the headphones. This feedback meant you did not have a pure sine wave waveform. The photo below, on the left, is the waveform with the feedback from the Kennedy Receiver Model 110. It is a form of audio modulation. The other photo, below on the right, is what is produced when there is no feedback. Dr. Rife always wanted to use a pure waveform. The fact that we could actually listen to the original type of equipment that he used made it so we could understand what Dr. Rife was doing.

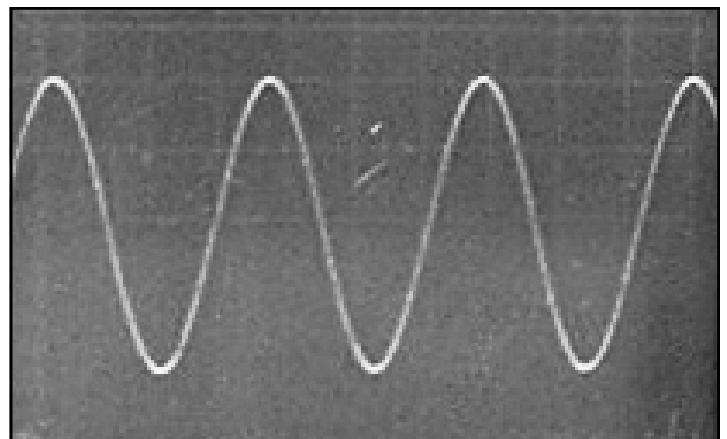
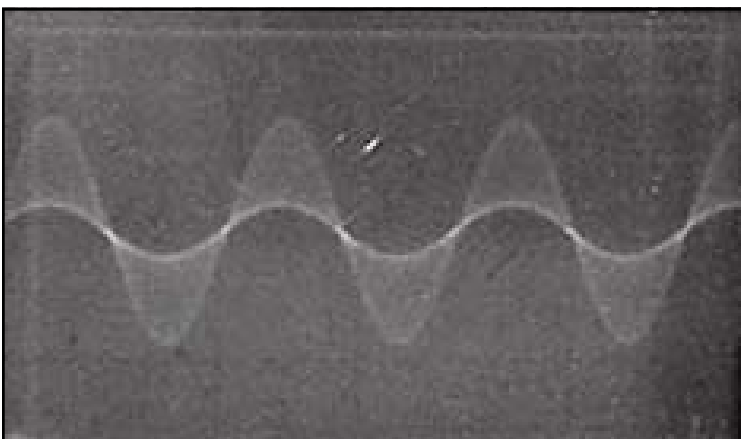



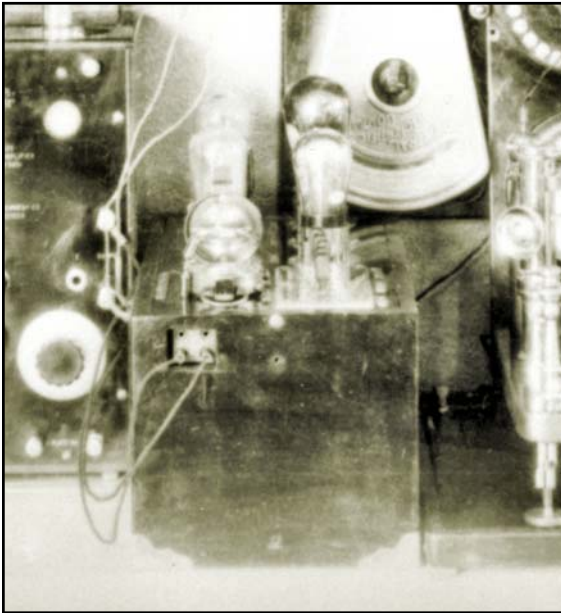
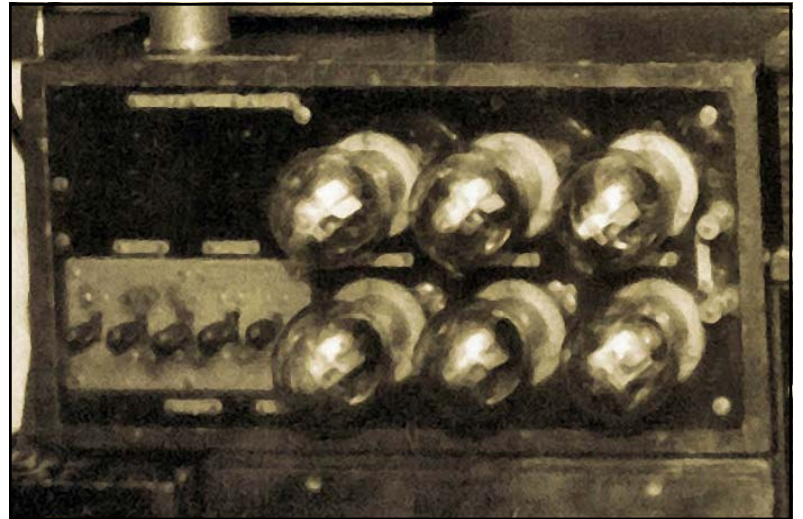
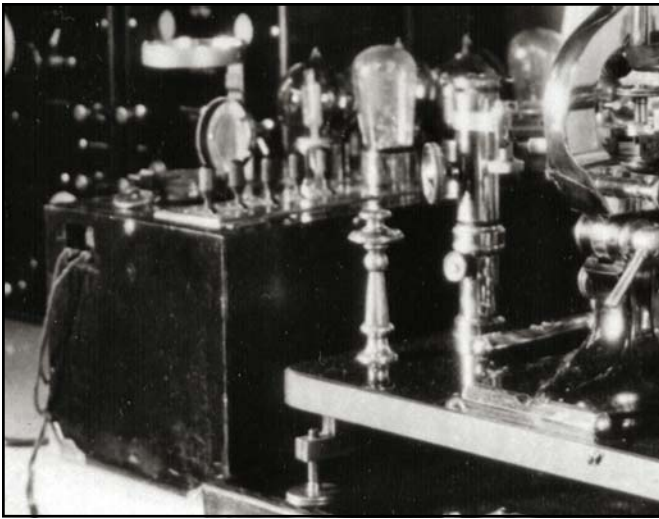

We will now discuss Dr. Rife's multi-stage-amplifier that he used with the Kennedy equipment. This was most likely a class A RC coupling cascade style amplifier. Daven Company started building this type of amplifier back in about 1925. Dr. Rife may have had Daven custom build his multi-stage-amplifier but we cannot be sure. The two photos, at the bottom of this page, are Daven amplifiers. One is a three stage amplifier and the other is a four stage amplifier. The Kennedy Receiver Model 110 only output about 1.5 to 3 volts. Dr. Rife needed to be able to amplify the signal to a high enough power level to make it effective. In the three old lab photos above we see Dr. Rife's multi-stage-amplifier. In the above photo, bottom right, you can see the type of tubes he would have used in the early to mid 1920s. These tubes would have made it so Dr. Rife could amplify the signal from the Kennedy Receiver Model 110 to about 50 watts in multi-stages. If you look at the above three photos of Dr. Rife's multi-stage-amplifier you will see five switches. These five switches (representing five-stages) made it so he could choose different power levels determined by how many stages of amplifi-



cation he wanted to use. With this configuration he could have easily produced the 50 watts he said he used. This 50 watts, was the power level that was mentioned in the Rife CDs for this instrument.

Ben Cullen, a close friend of Dr. Rife's, mentions on the Rife CDs that Dr. Rife would light the ray tube with a separate power source. His lab photos show a spark gap transmitter which he used to light the ray tube. If you look at Dr. Rife's lab photo, top right, you can see the spark gaps. The photo below the lab picture shows a spark gap transmitter diathermy from the 1920s. We purchased it so we could test the lighting of a ray tube with it. The next photo below the spark gaps shows the lighting of the ray tube using this spark gap transmitter. It lit the ray tube with ease and could output more power than the ray tube could handle.

This spark gap transmitter would make it so Dr. Rife didn't have any difficulties tuning the ray tube when he changed frequencies from a low frequency of 139,000 hertz to a higher frequency of 1,604,000 hertz. The spark gap transmitter had a damped waveform and would have given him a damped wave carrier frequency (see the photo, bottom right) most likely somewhere around one Megahertz. This transmitter we purchased has a frequency of 920 KHz. Dr. Rife would not have modulated frequencies onto this carrier frequency but would have just mixed the frequencies in the ray tube (photo below is of sine & spark mix).

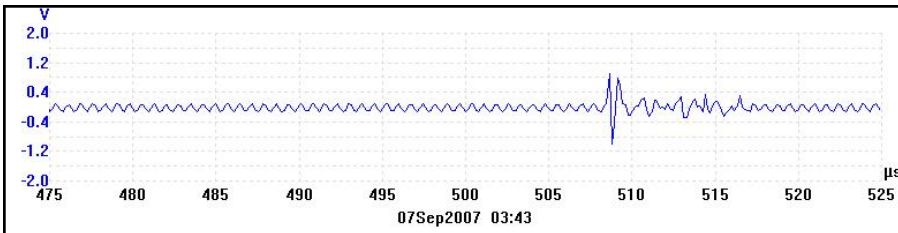
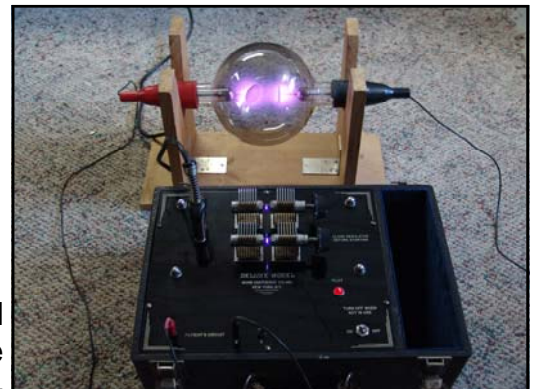
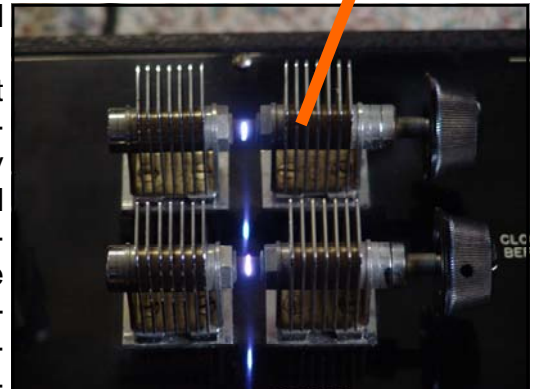
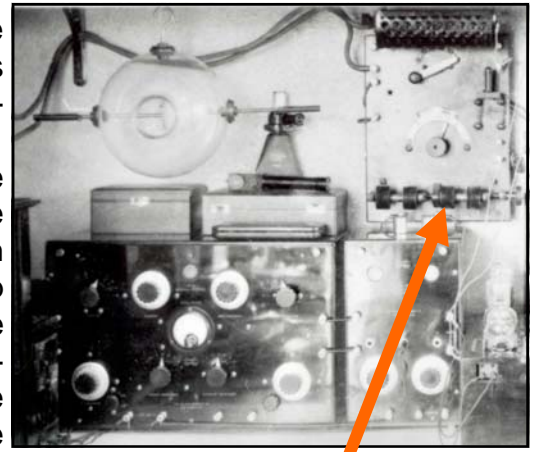

Mixing would have given him the combination of a damped wave and one or two sine wave frequencies, depending on if he used two sine wave frequencies simultaneously. We do not believe that Dr. Rife continued to use a spark gap transmitter because it would have made it impossible for him to read the ray tube harmonic frequencies that his ray tube output. This is because a spark gap outputs broadband noise that makes it impossible to read any harmonic frequencies. Dr. Rife must have only used the spark gap transmitter in his early work. The Beam Rays instrument built by Philip Hoyland used an audio frequency to gate the RF frequencies it output. This audio frequency gate will be discussed when we look at the Beam Rays instrument.

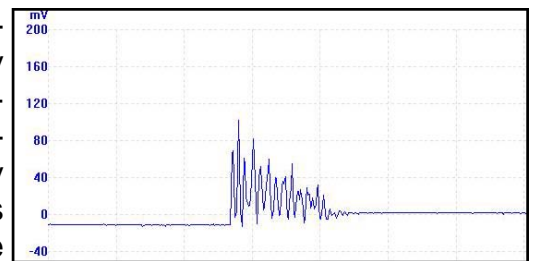

Spark gap damped waveform

This gating would have given Dr. Rife's frequencies a very high potential voltage spike. John Crane made this statement when he was narrating Dr. Rife's lab film.

**CRANE:** "Now the spikes that you see on the frequencies are the lethal part that kill and devitalize the virus. They are the resonant peaks of the frequencies which increase the voltage to a very high potential which the cells of the virus wall can not tolerate and they break up into many pieces and are destroyed." (Dr. Rife's Lab Film Narrated by John Crane in the 1970s)

The audio gate frequency is most likely the reason why Dr. Rife was able to devitalize the many microorganisms he tested. We will now discuss Dr. Rife's frequencies. He described the method he used to find these frequencies on the Rife audio CDs.

**RIFE:** *"Because when I check on that thing and look through that microscope hour after hour day after day, tuning that damn thing [Kennedy 110] to find something that will kill that bug. And every hour or half an hour, whatever is required, I put a new fresh culture under the microscope and keep that on and I find something that folds it up, alright!"* (John Marsh Rife CDs - CD 7 track 2)

Below and on the next page are Dr. Rife's misread lab note frequencies which he recorded prior to 1934. Each lab note had two frequencies. One was listed in cycles per second and the second was listed in meters. For the purpose of making this article easier to understand the meter frequency on Dr. Rife's lab notes has been converted to cycles per second or hertz. You will notice that there are two audio frequencies listed for organisms that are above 12,000 hertz. They are the only audio frequencies ever listed by Dr. Rife for any organisms. One of them was changed to a higher RF frequency when Philip Hoyland read the correct frequencies. Most likely the other audio frequency was really a higher RF frequency.

### Dr. Rife's misread lab note frequencies from before 1934

	First Frequency In Hertz	Second Frequency Meters to Hertz
<b>Actinomycosis (Streptothrix)</b>	678,000	186,554
<b>Anthrax</b>	900,000	272,539
<b>Anthrax Symptomatic</b>	400,000	<b>16,655 Audio range</b>
<b>B. Coli (Rod form)</b>	683,000	317, 914
<b>B. Coli (Filterable virus)</b>	8,581,000	11,103,424
<b>Bacillus X &amp; Y. Cancer</b>	11,780,000	17,033,662
<b>Bubonic Plague</b>	160,000	512,466
<b>Catarrh</b>	1,800,000	1,713,100
<b>Cholera Spirillum</b>	851,000	960,873
<b>Contagious Conjunctivitis</b>	1,206,000	2,025,625
<b>Diphtheria</b>	800,000	1,090,154
<b>Glanders</b>	986,000	736,591
<b>Gonorrhea</b>	600,000	150,649
<b>Influenza</b>	1,674,000	1,946,704
<b>Leprosy</b>	743,000	251,926
<b>Pneumonia</b>	1,200,000	381,901
<b>Spinal Meningitis</b>	927,800	1,795,164
<b>Staphylococcus Pyogenes Aureus</b>	998,740	555,171
<b>Staphylococcus Pyogenes Albus</b>	This frequency found in Rife's papers	549,070
<b>Streptococcus Pyogenes</b>	1,214,000	2,111,214
<b>Syphilis (Treponema Pallidum)</b>	900,000	2,775,856
<b>Tetanus</b>	700,000	<b>15,779 Audio range</b>
<b>Tuberculosis (Rod form)</b>	583,000	541,142
<b>Typhoid Fever (Rod form)</b>	900,000	868,964
<b>Typhoid Fever (Filter passing)</b>	9,680,000	13,943,835

## 1935 Rife Ray #4 instrument

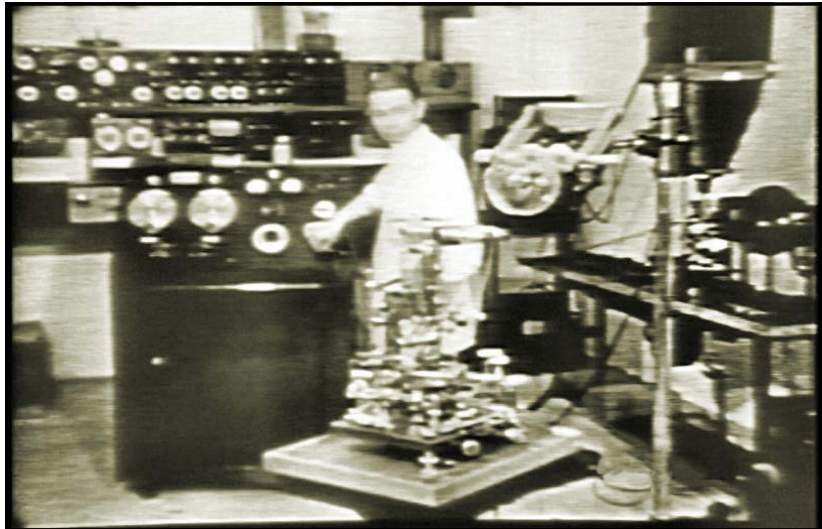

- 1) Used a ray tube.
- 2) Had two separate oscillators so it could output two frequencies at a time. Frequency range was from 87,000 Hertz to 22.5 MHz.
- 3) Power usage was about 450 to 600 watts. Output to the ray tube was variable (50 to 100 RF watts).

Some have asked how we can be sure these photos we have are of the Rife Ray #4. It is a simple process of deductive reasoning. John Crane, one of Dr. Rife's 1950's business partners, incorrectly dated the Rife Ray #4 as a 1942 instrument and this has led to the confusion which we will now attempt to clear up. In the photo above on the right we see Dr. Rife using the instrument which John Crane dated as built in 1942. However, the lab film this picture was taken from was made in the summer of 1936 for use at a conference which Dr. Rife planned to attend in the autumn of that same year. He was presenting this film at this conference to demonstrate the isolation of the BX cancer virus. This properly dates the instrument as having been built before the summer of 1936 and indicates that John Crane was incorrect. In the background of this photo, behind the instrument Dr. Rife is using, we see his Kennedy Company equipment back against the wall. Therefore this instrument would have been built in late 1935 or early 1936. The Rife Ray #4 documents show it was completed in the fall of 1935. This logically dates the instrument he is using in the 1936 film as the Rife Ray #4. Bertrand Comparet, Dr. Rife's attorney, said three of these instruments were built. Dr. Milbank Johnson, M.D., used one in his clinic in 1936 and Dr. Rife had one in his lab. It is not known what became of the third instrument.

With the proper dating of this instrument (which shows it is the Rife Ray #4) we will now discuss it in detail. As pointed out earlier in this article Philip Hoyland built the Rife Ray #4 instrument for Dr. Rife and Dr. Johnson in 1935. The Rife Ray #4 instrument documents show it could put out two RF or radio frequencies simultaneously. Dr. Rife's previous Kennedy Model 110 when connected to the Model 281 could output two frequencies simultaneously like the Rife Ray #4. It also could do a form of modulating audio frequencies. The Rife Ray #4 instrument no longer included an variable audio oscillator which indicates that Dr. Rife did not believe that it was necessary any longer for M.O.R. work. All of the frequencies that Philip Hoyland read from the Kennedy Model 110 and transferred to the Rife Ray #4 were RF frequencies. The lowest frequency was for Anthrax at 139,200 Hertz; the highest was 1,604,000 Hertz for the BX and BY organisms that caused cancer. The Rife Ray #4 would have also been a sine wave instrument just as the Kennedy Company equipment was. Since the Rife Ray #4 had two high frequency oscillators it could allow for one oscillator to be set at a higher frequency if the M.O.R. frequency was too low to light the ray tube. However, all the documents we have indicate the Rife Ray #4 instrument had a fixed carrier frequency the same as the Kennedy instrument did. There would have been no modulating with this carrier frequency, only mixing because any tank coil used

would have filtered out any frequencies that exceeded its bandwidth. This carrier frequency would have been used to make sure the ray tube stayed lit while he output two frequencies simultaneously. This statement of Dr. Rife's verifies this fact.

**RIFE:** "We found the frequency of the virus, we found the frequency of the rod, which we had for years of course. But if we use the two of them simultaneously over the same carrier wave, the patient gets well and the Guinea pig gets well, but if you use one or either individually you either kill the patient or you don't do nothing". (Marsh collection, Rife audio CDs )

Dr. Rife used the Rife Ray #4 in his lab for years. Dr. Johnson used his Rife Ray #4 instrument in at least three medical trials. Below is one of his release cards that each patient had to sign in order to be treated with the frequencies output by the Rife Ray #4 instrument.

**RELEASE**

It has been determined that I, F. G. Adamson, am suffering from a malignant disease which I believe to be Sinus infection and I am informed that Dr. Milbank Johnson and his associates have been experimenting with a new method of treatment of said disease upon the lower animals with sufficient success to lead me to hope that it may be successful in my case. However, I wish it distinctly understood that neither Dr. Milbank Johnson nor his associates have made any promises, claims, representations or other assertions as to the outcome of their new method of treatment; Dr. Milbank Johnson and his associates have agreed to subject me to their new method of treatment without charge to me and in consideration of their services in this connection, I hereby consent to allow Dr. Milbank Johnson and his associates to subject me to their new method of treatment of my disease and further do consent to allow said Dr. Milbank Johnson and his associates to subject me to any other type of treatment, whether operative or otherwise, that they may in their opinion deem necessary or advisable in connection therewith or as a result thereof; and further, I hereby release said Dr. Milbank Johnson, his associates, employees and attendants, from any and all liability for any untoward results that I may suffer in connection with or as a result of any such treatment or treatments, whether operative or otherwise, with the full realization on my part of the experimental character of said new method of treatment. I agree that this consent and release shall be binding upon my heirs and legal representatives and that the same shall extend to and release the heirs and legal representatives of said Dr. Milbank Johnson, his associates, employees, and attendants. It is further understood that this release shall extend to and include any hospital or clinic that Dr. Milbank Johnson or his associates may be associated with, and also their respective staffs, employees, and attendants.

I have asked certain of my relatives to agree to the terms of this instrument and they have signed below.

Dated at San Diego this 24<sup>th</sup> day of August 1936

Witness: \_\_\_\_\_

F. G. Adamson  
PATIENT

I or we hereby agree to be bound by the above: \_\_\_\_\_

RELATIONSHIP \_\_\_\_\_

RELATIONSHIP \_\_\_\_\_

When Dr. Johnson was using his Rife Ray #4 instrument in his lab he had an interesting effect take place. His Rife Ray #4 instrument malfunctioned when he was testing it on some microorganisms. He wrote about what happened in a letter which he sent to Dr. Gruner and Dr. Rife on November 4, 1936:

**DR. JOHNSON:** "Last summer, in hunting for the M.O.R. for the other two reproductive forms of the *cryptomyces pleomorphia*, we ran into a new band of oscillations which introduced itself to us by killing all three forms - those that we called BX, our filter-passing form; then a transitional form such as you found in the monocytes in the blood; and then the third or highly developed form coming from the sporangium forming from the hyphae of the mycelium. At the same time that this new wave band arrived, we broke all the glass in the laboratory of a certain shape, not only in the room where we were working but in all the other rooms...we had been troubled a great deal with a mold because in the microscope room there were no windows, but this band not only destroyed that mold, which was growing on the leather objects in the room, but every bacteriological culture that we had in the laboratory! It cleaned us out completely so we had to start from scratch and replace our losses. In fact, we were all so surprised that we began to feel each other's pulses to see if we were still alive. As no harm had been done to us, we proceeded to test the new band out on mice, rats, rabbits, guinea pigs and dogs. So far as we were able to discover, it is not at all destructive or injurious to normal cell tissue. While we have been forced

*to modify our machine so as to produce this new band, still it is so much more effective clinically that we look upon it as a very advantageous discovery. However, our experience has forced us to do all of our experimenting with the new ray completely outside of our laboratory building or abandon all form of bacteriological experiments, because it instantly kills them all."*

The Rife Ray #4 oscillators somehow began to over-oscillate and created what is called parasitic oscillations. If one takes into consideration the "one tenth of one meter" given by Dr. Rife as the tolerance of how accurate a frequency needs to be then it is possible that enough frequencies were generated to produce all the M.O.R. frequencies to kill every organism in Dr. Johnson's lab. The glass that broke was not just regular glass - it was crystal. The frequency for crystal is about 560 Hertz and must have all the harmonics with it or it will not break. The Rife Ray #4 instrument didn't have an audio oscillator but an audio frequency harmonic was produced which broke the glass. Today we have the ability to produce hundreds of frequencies out of one processor. This effect could be produced today and an instrument could be built that would be able to hit the M.O.R. of every organism through a series of controlled sweeps. The most significant effect would be that the M.O.R. for every known and unknown organism could be hit and we would never have to hunt for an M.O.R. again.

Below are the frequencies read off of the Kennedy Company equipment and used in the Rife Ray #4 instrument. We now know these frequencies were the frequencies used in the 1934 clinic.

#### Rife Ray #4 frequencies

<b>Actinomycosis (Streptothrix)</b>	192,000
<b>Anthrax</b>	139,200
<b>B. Coli (Rod form)</b>	417,000
<b>B. Coli (Filterable virus)</b>	770,000
<b>Bacillus X or BX (Cancer carcinoma &amp; sarcoma)</b>	1,604,000
<b>Gonorrhea</b>	233,000
<b>Spinal Meningitis</b>	427,000
<b>Staphylococcus Pyogenes Aureus</b>	478,000
<b>Staphylococcus Pyogenes Albus</b>	549,070
<b>Streptococcus Pyogenes</b>	720,000
<b>Syphilis</b>	789,000
<b>Tetanus</b>	234,000
<b>Tuberculosis (Rod)</b>	369,000
<b>Typhoid Fever (Rod form)</b>	760,000
<b>Typhoid Fever (Filter passing)</b>	1,445,000

Many people have wondered why Dr. Rife did not list two high RF frequencies for the BX and the BY organism in his lab notes or in the Rife Ray #4 documents. Many have thought that it was lost or not written down when Philip Hoyland read the Kennedy Company equipment. We believe we have found the reason why two frequencies were not listed when it came to the BX and the BY organisms. Dr. Rife lists in his lab note paperwork that the BX was a purple red color. He also said that the BY was also purple red. The BY he said was just larger in size. The reason there is no frequency given by Dr. Rife in any of his paperwork for the BY is because the frequency for the BX must also have killed the BY. They both had the exact same color and the same chemical constituents. This could only mean the same frequency killed them both. I do not know why anyone has not made this connection in the past. What caused me to notice it was when making the new DVD called "**Royal Rife-In His Own Words**" In this DVD I used Dr. Rife's own voice as a commentary. I observed that he made a very interesting statement. John Crane recorded Dr. Rife for about 50 minutes talking about his work in bacteriology. Here are Dr. Rife's verbatim statements:

**RIFE:** *"Now we will come to the BX again. The BX [purplish red] will pass through the porosity of the W berkefeld filter...now we alter the media slightly of that organism, in the tube, and we have another purplish red organism that we call BY. Now this organism is considerably larger than the BX".*

From this statement made by Dr. Rife he confirms that the BX and the BY are the same color.

**RIFE:** *"We have done very little work on the Sarcoma because we do not associate that as a malignant tumor in comparison with the work we have done with the true Carcinoma".*

In this statement Dr. Rife said he did very little work with the Sarcoma and did not associate it as a malignant tumor in comparison with the Carcinoma.

**RIFE:** *"Many people believe that the Sarcoma will turn into a Carcinoma. We have found in some experimental animals that, that is true, but nothing that we can place as absolute".*

From this last statement we are told that a sarcoma will sometimes turn into a carcinoma. When we consider what Dr. Rife said there seems to be only one reason why there is no frequency for sarcoma. He must have never had one because, as he said, "*we have done very little work on the sarcoma*". Since a sarcoma would sometimes change into a carcinoma the frequency for the BX and BY also should work on sarcoma. It is also clear, BX and BY are for carcinoma not sarcoma. We all have been led to believe that BY was for sarcoma and it is not. It wasn't until the Verne Thompson 1940's and 1950's instruments did we see a separate frequency for sarcoma (20080 and 2008). How or why they came up with a separate frequency for sarcoma is not known. It may be that Philip Hoyland discovered something that he never told Dr. Rife.

## 1936 Clinical instrument

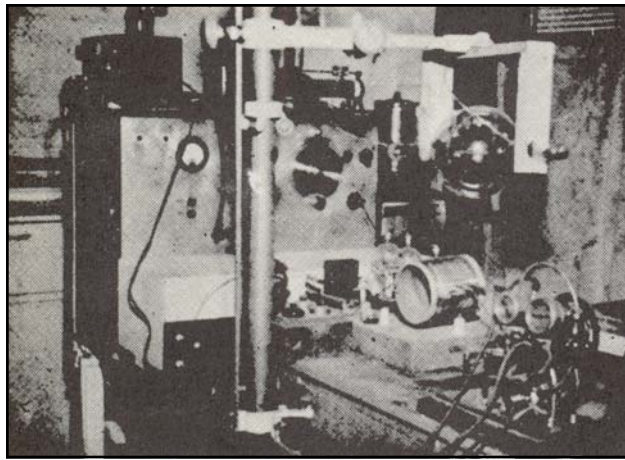

- 1) Used a ray tube.
- 2) Had two separate oscillators so it could output two frequencies at a time. Frequency range was from about 87,000 Hertz to at least 2MHz.
- 3) Power usage was about 450 to 600 watts. Output to the ray tube was probably 50 watts.

The instrument in the photo above was built in 1936 by Philip Hoyland. John Crane dated the instrument in this photo as being built in 1935 but we know that the Rife Ray #4 was built in 1935. We did not have enough information about this instrument until May of 2008. This is when Steven Ross let me scan the complete Beam Rays Trial manuscript. I would like to acknowledge his generous contribution of this information. I consider him to be a very kind and generous gentleman in every respect.

After reading for the first time the complete Beam Rays Trial manuscript I found there was more information about Dr. Rife's instruments in it that we did not have. This information made it possible to come to a conclusion of the minimum frequency range of this clinical instrument. Below are statements made by Philip Hoyland in the Beam Rays Trial that gives us some important information about this instrument:

**COMPARET:** *"The four machines bought by the British were two so-called laboratory types and two so-called clinical types, what was the difference between the two."*

**HOYLAND:** *"The clinical type was similar in all respects to the Rife machine."*

**COMPARET:** *"If you wanted to treat one [a person] with typhoid for instance wouldn't you have to set the machine so that it would be on a particular frequency?"*

**HOYLAND:** *"No, the machines were made so that they varied over a band of frequencies" [they would sweep across a range of frequencies].*

**COMPARET:** *"That band used for the treatment of each disease was different from other bands for the other diseases wasn't it?"*

**HOYLAND:** *"The whole list of bacteria that the machine was treating was divided into four bands." (Beam Rays Trial Papers, www.rife.org)*

This information I believe gives us a good indication of the frequency range of the clinical machine. The Rife Ray #4 had nine frequency bands that covered from 87,000 hertz to 22.5MHz (22,500,000 hertz). The first four bands of the #4 covered from 87,000 hertz to 2,140,000 hertz. These four frequency bands would cover the whole list of Dr. Rife's disease organisms as Philip Hoyland stated in his trial testimony. The trial testimony does not let us know if the clinical instrument had



more than four frequency bands. It is possible that it did have more but the instrument case was not as large as the #4 instrument case indicating that it did not have the same 87,000 hertz to 22.5MHz frequency range as the #4 instrument.

Another important fact we learn from the trial is the instruments had to be swept through the frequency range of the organism they were wanting to treat. Having built and tested many of these M.O.P.A. (Master Oscillator Power Amplifier) style instruments that Dr. Rife used we know that it was almost impossible to get right on the correct frequency using the variable capacitor dial (frequency tuning dial). You could turn the dial to what you believed was the exact same place and then test it and find that you were not on the same frequency. The frequency will be different each time you turn the dial and try and come back to the same place. These old M.O.P.A instruments could easily wander 30,000 hertz or more. This is probably why Philip Hoyland said; "*the machines were made so that they varied over a band of frequencies.*" One of the photos we have of a M.O.P.A Beam Rays instrument (the next instrument we will discuss) that Philip Hoyland built clearly has a switch marked sweep. This indicates that sweeping the instrument was a necessary requirement in order to hit the correct M.O.R. frequency.

Even though Dr. Rife and Philip Hoyland wrote down the frequencies for each organism this would only have been a close approximate. The master oscillators that were used back in the 1930's to read frequencies were only accurate within about 1/2 percent. At the BX frequency of 1,604,000 hertz this 1/2 percent inaccuracy would be 16,000 hertz plus or minus of the 1,604,000 hertz. Add to this the fact that Dr Rife was gating his frequencies from about 1330 hertz to 10,000 hertz in order to devitalize the organism. This means we can easily add another 10,000 hertz to this inaccuracy because of the creation of the side bands and the distance that they would be apart from each other. Then take into account that these M.O.P.A instruments, as pointed out, would wander quite a distance (30,000 hertz). This leaves us with the realization that the frequencies that Dr. Rife wrote down for each organism were only approximate frequencies.

From our tests of this old equipment it is entirely possible that the true BX frequency could be plus or minus some 50,000 hertz of the 1,604,000 hertz. Anyone using any of Dr Rife's high RF frequencies should take into consideration these facts when using these frequencies. Sweeping is absolutely necessary when using them.

## 1938-39 Beam Rays Corporation instrument

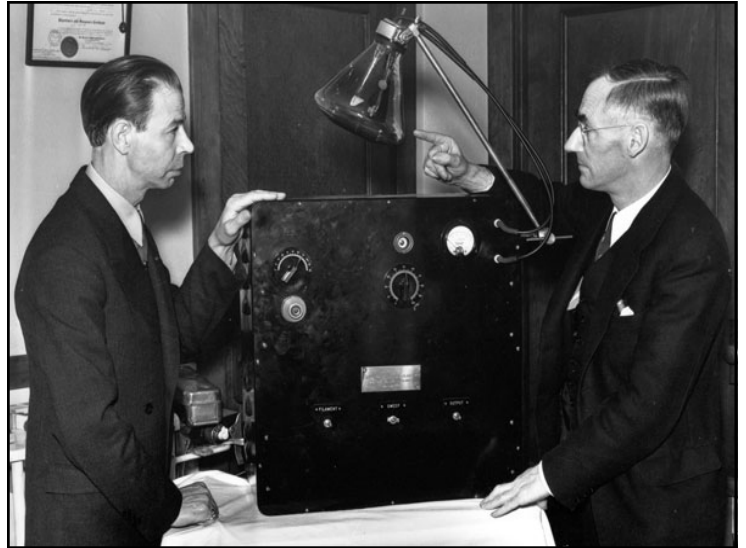
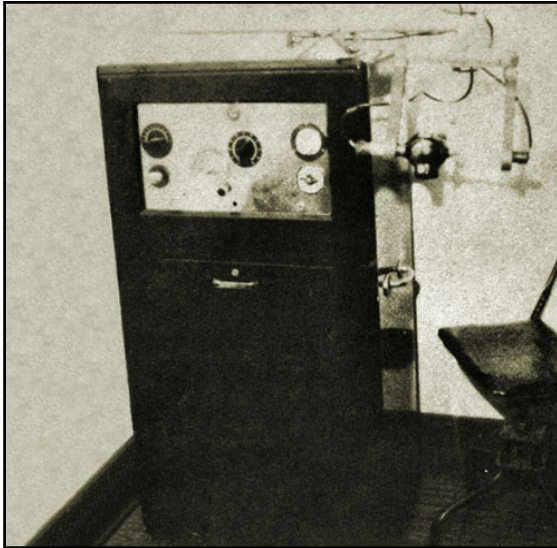

- 1) The instrument used a ray tube.
- 2) Had two RF oscillators. One variable and one fixed carrier frequency of 4.68 MHz.
- 3) Had a fixed audio frequency that gated or modulated the fixed carrier frequency.
- 4) Power usage was about 450 to 600 watts. Output to the ray tube about 50 RF watts.

Just as with the Rife Ray #4 we must determine what a Beam Rays Corporation instrument looked like. The reason we need to determine this is because unless we know what those instruments really looked like we may think we have a true Beam Rays instrument and find out later that it is not one. And this, in fact, is exactly what happened. We mentioned this earlier and will talk about this later on in this article. First we will prove the photos we have are photos of Beam Rays instruments. The instrument above on the left is a photo of one of two instruments owned by Dr. James B. Couche which he purchased from Beam Rays Corporation. Dr. Couche sold this instrument to Dr. Tully in 1951. This photo gives us an instrument we can make comparisons against when looking at other instruments. The above photo on the right is of Dr. Rife and Philip Hoyland his engineer and business partner in Beam Rays Corporation. In the photo is an instrument. We will prove that this instrument is also a Beam Rays instrument by making some comparisons. This photo of Dr. Rife and Philip Hoyland was taken for a May 6, 1938 newspaper article published by the San Diego Tribune. In the newspaper the caption below the photo said: "Royal Raymond Rife, left and Philip Hoyland with Rife ray apparatus". At this time Beam Rays was selling its instruments to doctors and this front page newspaper article had the capability of selling a lot of instruments. It is only logical they would have used the instrument they were selling. The next two photos below are close-up photos of these instruments. You will notice the

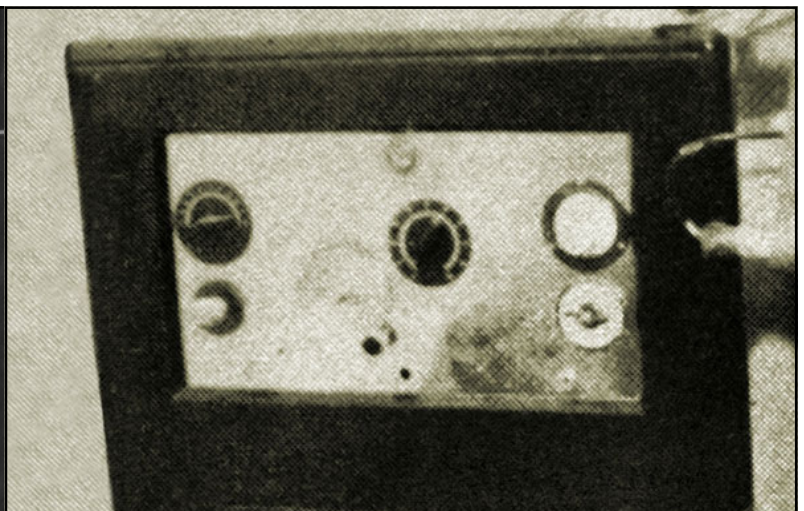
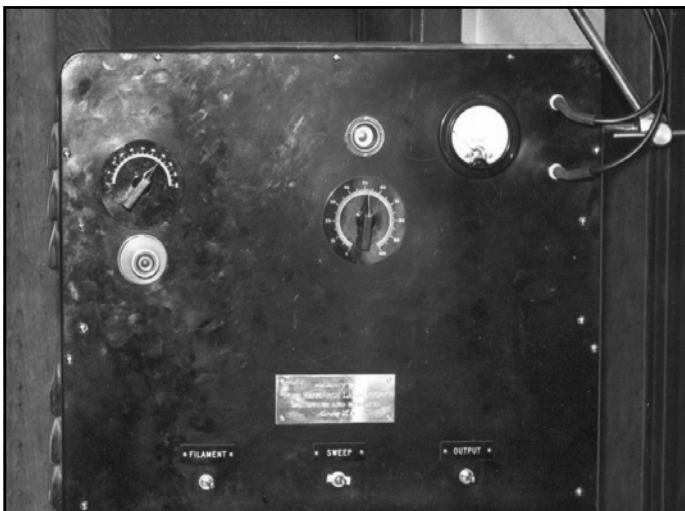

similarities of these two instruments. They are almost exactly alike except for the case. Dr. Couche's instrument was in a case that extended all the way down to the floor. It had handles on the side and wheels on the bottom which would make it very easy to move around. Both instruments have one oscillator dial which is located on the left side of the front panel. Below that dial on Dr. Couche's instrument was a light and on the other instrument is a light also. The second dial, in the center, goes to 100 and was the amplitude dial for balancing the amplitude modulation of the gate frequency. Above that dial on both instruments is a tuning eye for calibrating the instrument's 4.68 RF carrier frequency. In the photo on the right is one of these tuning eye tubes. They both have a milliamp power meter located all the way over to the right next to where the ray tube is connected. Dr. Couche's instrument had a timer below the power meter to help him make sure he treated the patient for the correct amount of time. Along the bottom are the filament, sweep and output switches which are not clearly marked on Couche's instrument but we can see what appears to be three different switches, two below the center amplitude dial and one below the timer. The comparison we have just made with Dr. Couche's Beam Rays instrument shows they are both Beam Rays instruments.

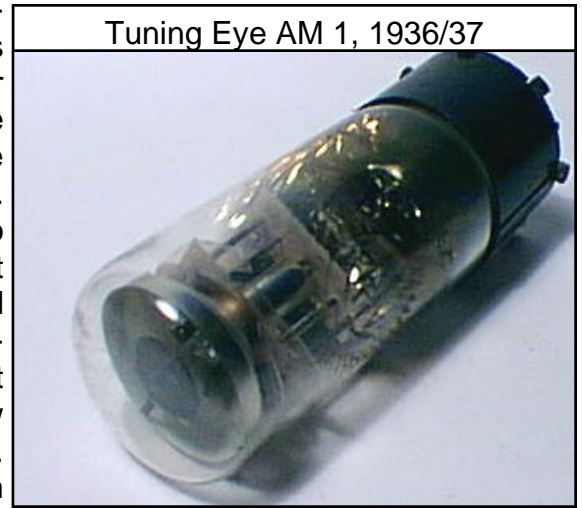

Philip Hoyland's Beam Rays instruments, until now, were believed to use audio frequencies modulated onto a fixed carrier frequency. We now know through the rebuilding and testing of the original Beam Rays instrument that this information is not correct. We will cover this new important information after reading the following quotes. This new information will show that it was Dr. Rife and Verne Thompson, not John Crane, who first came up with the use of audio frequencies. This new information also shows that Dr. Rife and Verne Thompson changed the Beam Rays instrument early in the 1940's by taking out what Dr. Rife believed were harmonics. In a letter which he sent to Dr. Gonin in 1939, there are indications that Dr. Rife wanted the so-called harmonics removed:

**RIFE:** *"I spoke only Friday evening to a Mr. John Chamblin, a radio man now connected with Beam Rays Inc., about the redesign and building of a device according to the old Rife Ray principles; as the present instrument has been so deviated away from that old principle that it is nowhere near the same...those devices which you have are merely working on a harmonic and not a true frequency; and in our research on electronics, we definitely know that there is no possible way of controlling electrical harmonics of a frequency."* (Letter from Dr. Rife to Gonin dated May 14, 1939)

Dr. Rife had left Philip Hoyland to build the Beam Rays instrument however he wanted to as long as it worked on his principles. Dr. Rife did not know that Philip Hoyland had changed the instruments to use a different method of producing the frequencies. Dr. Rife believed they were using the Rife Ray #4 RF frequencies along with harmonics. This was pointed out in the 1939 Beam Rays trial:

**COMPARET:** *"Has the Plaintiff [Philip Hoyland] ever informed you that the machines that he designed and built for the Beam Ray were not operating on the same frequencies as your own?"*

**RIFE:** *"They were supposed to be operating on the same...with harmonics."*

Philip Hoyland when he was on the stand was asked:

**COMPARET:** *"I understand that you say that the frequencies used in the machines put out by the corporation were not set to the same frequencies as Dr. Rife's machines [Rife Ray #4]."*

**HOYLAND:** *"That is correct."*

**COMPARET:** *“Then it was during the period between September and November that you told Edwards at his home that the machines you were building were not putting out the same frequencies as Dr. Rife’s machines?”*

**HOYLAND:** *“Yes.”*

**COMPARET:** *“How did you explain that?”*

**HOYLAND:** *“In the summer of 1936 I designed a new machine, or rather I checked it there at the lab [The Beam Rays instrument]. I had designed it in Pasadena, and we tested it out then and the frequencies were not the same as on Dr. Rife’s machine.”*

**COMPARET:** *“Did you tell him how great the difference it was?”*

**HOYLAND:** *“I explained that there was quite a fundamental difference.”* [Harmonic frequencies]

Comparet when asked a question by Judge Kelly said this:

**COMPARET:** *“Hoyland has said that the design and the frequencies of the machine itself is not that of a Rife Ray machine, and that the machine is in fact different. The company will have to have these machines junked, must draw up new designs according to Dr. Rife’s ideas, must have Dr. Rife ok these designs, etc...Dr. Rife is not going to be a party to a fraud, and if the machines we sell are not the true Rife machines they are a fraud.”* (Beam Rays Trial Papers, www.rife.org)

When Edwards was on the stand he said this:

**COMPARET:** *“Did Mr. Hoyland tell you at any time in the fall of last year that the machines he was manufacturing for Beam Ray corporation operated on a principle fundamentally different from Dr. Rife’s machine?”*

**EDWARDS:** *“Mr. Hoyland told me at one time that Dr. Rife thought that he had the frequencies but he didn’t have them [here Edwards is talking about the Beam Rays Corporation instruments not the Rife Ray #4 instrument because Philip Hoyland said, on the stand, that he gave the Rife Ray #4 frequencies to Dr. Johnson and Dr. Rife in 1935].”* (Beam Rays Trial Papers, www.rife.org)

Philip Hoyland also said this on the stand:

**HOYLAND:** *“Regarding the frequencies of the machine [Beam Rays Corporation instrument], you will remember me telling you that the frequencies used are not the same ones on the Rife machine [The Rife Ray #4]. They [The Rife Ray #4] were in the upper bands [139,000 to 1,604,000 Hertz].”* (Beam Rays Trial Papers, www.rife.org)

The trial manuscript shows that Philip Hoyland changed Dr. Rife’s instrument in a manner that Dr. Rife did not like. Let us now take a look at the history of the Beam Rays Corporation. Philip Hoyland became Dr. Rife’s Engineer in 1935 when he built the Rife Ray #4. In 1936 Philip Hoyland also began building a new instrument that would be sold in 1938 by Beam Rays Corporation. Dr. Rife, Philip Hoyland, Dr. Couche and several other men started this company in order to commercially sell the instruments to doctors. Philip Hoyland (who may have had a little larceny in his blood) made changes to this new instrument without telling Dr. Rife about those changes. Even though what Philip Hoyland did was not morally correct, there are some good reasons why he built the instruments the way he did. Dr. Rife and Philip Hoyland became partners in Beam Rays Corporation in 1938. Dr. Rife had 45% ownership and Philip Hoyland held 55%. Philip Hoyland was worried about keeping the origi-

nal frequencies a secret because he felt people would try to steal their technology. This concern of Philip Hoyland's was not unfounded because Mr. Parsons of the British Group did try to steal their instrument. From the trial we learn they had no way to patent the instrument because everything they were doing was in public domain in regards to the frequency generating equipment. Philip Hoyland felt that he had to come up with a way to keep anyone from finding out what the true frequencies were. So he built the instrument a different way supposedly using harmonics to hit the frequencies of the Rife Ray #4 and Kennedy Model 110. It appeared that unless a genuine Beam Rays instrument could be found and tested, we would never know for sure how Philip Hoyland generated and used the reported harmonics in his instrument. Dr. Rife made this statement about Philip Hoyland in a letter written on March 22, 1958:

**RIFE:** *"Hoyland was like many men with whom I have associated over a period of years. In short time he began changing the basic principles of these instruments according to his own ideas."*

To sum things up, until February of 2008 what you have just read from the Rife documents is all we knew about Philip Hoyland's original instrument. We knew it had a fixed carrier. We thought it used audio frequencies, not Dr. Rife's principle of high RF frequencies. We also thought that it was designed to work on harmonics which interacted with the audio frequencies to produce a harmonic frequency that would eliminate the various pathogenic organisms. What lower harmonic M.O.R. frequencies were produced and used was not known but they were believed to have been calculated from the Rife Ray #4 frequencies. We believed the audio frequencies used in the Beam Rays instrument were also used in Aubrey Scoons, Verne Thompson 1940's instrument.

We now know that most of this information is incorrect. From the documents we know that Philip Hoyland put a lot of work into this instrument and didn't finish it until late 1936 or early 1937. Benjamin Cullen said Philip Hoyland spent a lot of time at the lab and stated the following in a taped interview in the 1950s:

**CULLEN:** *"Philip Hoyland was in there quite a lot...Hoyland developed some few items in the lab...Hoyland seemed to help quite a lot and he got into the bacteriology side with Rife a good deal because Rife had so much to work out...he finally got to the point where he [Dr. Rife] had to delegate some of the work."* (John Marsh Rife CDs, CD 6 track 1)

From the trial we learn that Philip Hoyland developed and tested his instrument in the lab. How could Philip Hoyland have tested it unless he put micro-organisms under the microscope? From the trial papers we learn that Philip Hoyland didn't tell Dr. Rife what frequencies he was using in the instruments. Dr. Rife thought the instruments were using his frequencies (the upper band frequencies) but with harmonics because this is what Philip Hoyland told him. We read earlier that Dr. Rife eventually found out about the changes Philip Hoyland made and was very unhappy because he believed that the instruments were not working on his frequencies or principles. The information that we now have shows that Philip Hoyland's instrument was working on Dr. Rife's principles and on his frequencies but in a different manner than Dr. Rife was used to using. This is the reason that the instrument worked so well. Philip Hoyland was still using Dr. Rife's principle of coordinative resonance but hid the truth from Dr. Rife. We will now look at the new information starting on the next page.

## The Gruner schematic of Philip Hoyland's Beam Rays instrument

Jim Peters, Jason Ringas, and I had been looking at the Beam Rays instrument in hopes of trying to figure out how it worked. I had built and tested both the 1950's AZ-58 and 1940's Aubrey Scoon, Verne Thompson instruments. Neither of these instruments ever obtained the same results as the original Beam Rays instrument. All the documentation we had showed that there were changes made to the original Beam Rays design which compromised the 1950's AZ-58, and 1940's Aubrey Scoon, Verne Thompson instruments. John Crane, over the years told many people that the AZ-58 and the frequencies it used were Dr. Rife's original frequencies. The Rife documents we have show that what John Crane claimed was not correct. Dr. Rife was not using audio frequencies in 1934 as John Crane and John Marsh claimed. Rebuilding of the AZ-58 and Aubrey Scoon instrument partially made the rediscovery of the Beam Rays instrument possible.

At the 2003 Rife Conference, Ron Rockwell put up the Gruner schematic of an original Beam Rays instrument. From reading the Rife documents I knew that this schematic existed because John Crane had mentioned it in his papers. John Crane said that the AZ-58 was built from that schematic. When I saw it I knew it was important, so I took still photos of it with my video camera. Because the video camera only had a one mega-pixel capability I took many up close photos knowing I could put it back together at a later date. Back in 2004 I gave this schematic to Aubrey Scoon and his British Rife group in hopes that they could look it over and correct any mistakes that may have been made. They redrew the schematics, without fully correcting them and put them up on their web site because I wanted everyone to have access to them.

Back on July 27, 2007 Stuart Andrews, who was one of the British Rife group and I got into another conversation about the Gruner schematic. He asked me to send him another copy of the original Gruner schematic so he could look it over again. An email conversation began at that time which included Jason Ringas, Jim Peters, Stewart Andrews, Jim Berger and myself. Jim Peters immediately noticed that the schematic that had been redrawn by the British group had some errors in it. Discussions continued on and off for a few months until one day Jim Peters noticed an oversight when looking over the schematic again. This oversight was the key to understanding how the Beam Rays instrument really worked.

Jim Peters sent Jason Ringas and I an email. He mentioned that a possible test could be made that would determine if this observation of his was the key to understanding how the Beam Rays instrument really worked. I called Jim Peters and had a discussion with him and he told me how we could make these tests. I told him that we did not need to do the test with solid state frequency generators because I had conducted a similar test back when John Bedini and I were working on the AZ-58 tests. John Bedini and I knew that the original Beam Rays instrument was a lot more powerful than the AZ-58 because of the Rife documents. The AZ-58 only output about 15 watts from the ray tube. I told him that I still had my 1940s Aubrey Scoon replica and several AZ-58's on the shelf. I told John Bedini that the original Beam Rays instrument, from the documentation that we had, output about 50 to 60 watts from the ray tube. He told me how I could make a test, by putting two AZ-58s together, which would give me about 60 watts out of the ray tube. I didn't know it at that time but that test was actually the way the original Beam Rays instrument worked. I told Jim Peters I would connect the AZ-58 and Aubrey Scoon instruments together again and make the tests that he suggested, but this time I would use my spectrum analyzer and we would fully test it out and find out if this was the method Philip Hoyland used. This test made the two instruments work exactly the same as the Gruner, Beam Rays schematic would have worked. This test was the key to understanding how Philip Hoyland's instrument worked. I had always stated that Philip Hoyland had to have come up with his method using math because they didn't have any spectrum analyzers back in 1936.

We will now show how Philip Hoyland's Beam Rays instrument worked and the frequencies he used. We can do this because we have been able to rebuild this instrument from the Gruner schematic. This information should be of great interest to all who have been interested in Dr. Rife's work. Philip Hoyland's design was ingenious to say the least. Whatever we may think of Philip Hoyland's character this does not change the fact that he was a good electronics engineer. I believe, had Dr. Rife

fully understood Philip Hoyland's design he most likely would have fully accepted it. But Philip Hoyland was not about to reveal the full details of his instrument to anyone because he had other plans, such as taking over the whole Beam Rays Company and getting rid of Dr. Rife.

### Rebuilding the Philip Hoyland Beam Rays instrument

We will now discuss the key to understanding Philip Hoyland's design. Jim Peters noticed that the British group had overlooked a second Hartley RF oscillator that was in the lower left corner of the Gruner schematic. They just believed this oscillator was the same RF fixed Hartley Oscillator that used the 809 tube. Below are four photos of the Gruner, Beam Rays schematic. On the left, is the complete Gruner schematic. On the top right, is the fixed RF carrier frequency section that used the 809 tube. The middle photo, on the right, is the second oscillator that was overlooked. You will notice that it says Hartley Oscillator. Because the first fixed oscillator that used the 809 tube is a Hartley Oscillator they just assumed that both of these oscillators were the same. This is where the error was made. If you

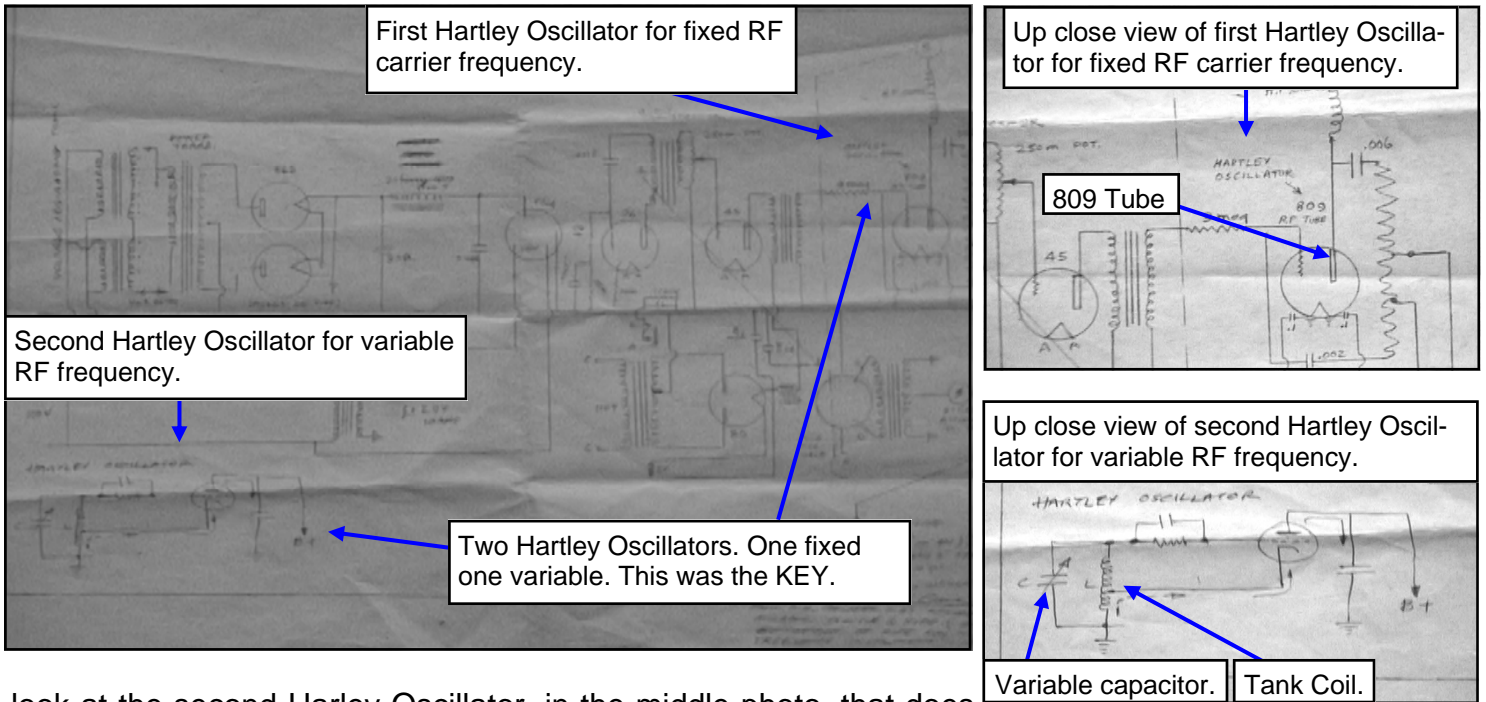

look at the second Harley Oscillator, in the middle photo, that does not use the 809 tube, you will notice that it has a variable capacitor. This variable capacitor shows that there were two Harley Oscillators. The fourth photo, bottom right, shows that the first fixed Hartley Oscillator was connected from the tank coil to the negative side of the ray tube. If you look closely at the photo you will notice that the positive side of the ray tube was also to be connected to a Hartley Oscillator. If you hooked the positive side of the ray tube back up to the same fixed Hartley Oscillator it wouldn't work. This is why there was confusion on how this instrument worked. The positive side of the ray tube is supposed to be hooked to the second variable Hartley Oscillator. The Ray tube is connected between the two Hartley Oscillators.

The second Hartley Oscillator was also an RF Oscillator. It has a tank coil and a variable capacitor for changing the RF frequencies. Anyone looking at this schematic will notice that it does not have any variable audio oscillator. Philip Hoyland's Beam Rays instrument was using RF frequencies not audio frequencies as previously believed.

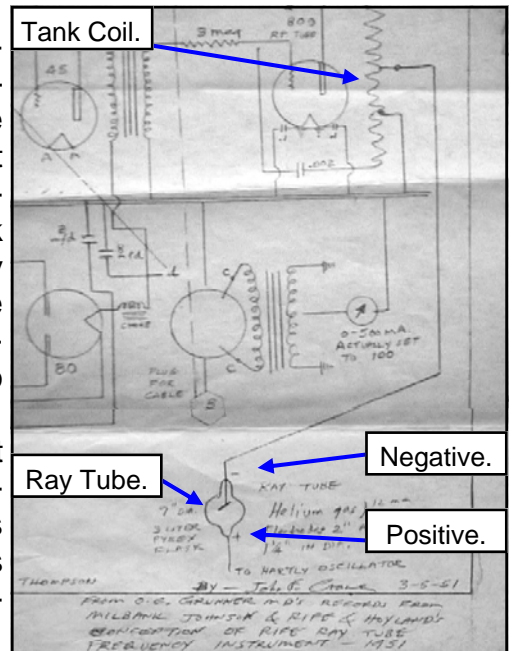

This means that the audio frequencies that we have attributed to Philip Hoyland were not his and must have come from Verne Thompson and Dr. Rife when they changed the Beam Rays instrument back in the early 1940s. Philip Hoyland's Beam Rays instrument design is very interesting. The second variable Hartley Oscillator is almost hidden because of its design. It is apparent that he didn't want Dr. Rife or the other members of the Beam Rays Corporation to know how the instrument worked. The logical way to build the instrument would have been to have had two Hartley Oscillators using the 809 tubes. But this would have given the design away. There would have been two large tank coils and two 809 tubes that everyone would have been able to see. Instead Philip Hoyland made the second RF oscillator with a smaller tube (#53) and smaller tank coil. This tank coil could have been easily hidden under the chassis. Dr. Rife was not an electronics engineer but he had been around electronics for many years and had wound his own coils. He would have known that the instrument had two RF Oscillators if he had seen two tank coils and two 809 tubes. This design definitely shows that the builder was trying to hide something. We know that Philip Hoyland seemed to have a little larceny in his blood because he tried to take over the Beam Rays Corporation and get rid of Dr. Rife and the other owners of the company.

Even though Philip Hoyland had these problems it doesn't mean that the Beam Rays instrument was a bad design. In fact it was an incredible design. Philip Hoyland told Dr. Rife that this new design worked on his frequencies with harmonics. Dr. Rife believed this and stated this fact in the 1939 Beam Rays Trial. Below is Dr. Rife's statement from the trial:

**COMPARET:** *"Has the Plaintiff [Philip Hoyland] ever informed you that the machines that he designed and built for the Beam Ray were not operating on the same frequencies as your own?"*

**RIFE:** *"They were supposed to be operating on the same...with harmonics."*

Philip Hoyland had told many others in the company that his Beam Rays instrument was not using the same frequencies that Dr. Rife's original instrument used. In the trial Philip Hoyland was trying to imply that he had found other frequencies that would kill the organisms. He also said that the Beam Rays instrument worked on a different principle. We will re-read the following statements made in the trial in order to show that Philip Hoyland was only telling half truths.

**COMPARET:** *"I understand that you say that the frequencies used in the machines put out by the corporation were not set to the same frequencies as Dr. Rife's machines [Rife Ray #4]."*

**HOYLAND:** *"That is correct."*

**COMPARET:** *"Then it was during the period between September and November that you told Edwards at his home that the machines you were building were not putting out the same frequencies as Dr. Rife's machines?"*

**HOYLAND:** *"Yes."*

**COMPARET:** *"How did you explain that?"*

**HOYLAND:** *"In the summer of 1936 I designed a new machine, or rather I checked it there at the lab [The Beam Rays instrument]. I had designed it in Pasadena, and we tested it out then and the frequencies were not the same as on Dr. Rife's machine."*

**COMPARET:** *"Did you tell him how great the difference it was?"*

**HOYLAND:** *"I explained that there was quite a fundamental difference."*



Philip Hoyland also said this on the stand:

**HOYLAND:** *“Regarding the frequencies of the machine [Beam Rays Corporation instrument], you will remember me telling you that the frequencies used are not the same ones on the Rife machine [The Rife Ray #4]. They [The Rife Ray #4] were in the upper bands [139,000 to 1,604,000 Hertz].”* (Beam Rays Trial Papers, www.rife.org)

There are several things of importance that were said in the trial that need to be pointed out. Since we recreated Philip Hoyland’s Beam Rays instrument by initially taking an AZ-58 and an Aubrey Scoon instrument and connecting them together, we found out how the Beam Rays instrument worked. From this test we were able to determine the truth of Philip Hoyland’s words given in the trial.

1. Philip Hoyland said this Beam Rays instrument was not set to the same frequencies Dr. Rife used. This was a true statement.
2. Philip Hoyland said that his instrument was not putting out the same frequencies that Dr. Rife used. This was a false statement.
3. Philip Hoyland said that his instrument operated on a principle fundamentally different from Dr. Rife’s machine. This was true.
4. Philip Hoyland said that his instrument worked on harmonics. This was a false statement.
5. Philip Hoyland said that Dr. Rife’s instrument was using frequencies in the upper bands implying that his instrument was working in the lower bands. This was a misleading statement.

By using the ingenious method of connecting the ray tube between the two Hartley Oscillators, one fixed, one variable, Philip Hoyland was able to produce all of Dr. Rife’s frequencies without the bandwidth problems that would have come with trying to modulate frequencies through a tank coil. The tank coils in the Beam Rays instrument can only pass modulated frequencies up to about 250,000 hertz. By putting the ray tube between the two Hartley Oscillators and heterodyning the frequencies in the ray tube Philip Hoyland was able to produce all of Dr. Rife’s frequencies. Dr. Rife’s #3 and #4 instruments put out specific frequencies. If Dr. Rife wanted 1,604,000 hertz he would set the oscillator to 1,604,000 hertz. This was the type of instrument Dr. Rife thought Philip Hoyland had built. If Philip Hoyland had built that type of instrument it would have been a lot bigger than the Beam Rays instrument. It would have been almost as large as the Rife Ray #4 instrument. It also would have required three or four tank coils and at least that many band switches in order to cover the desired frequency range. Philip Hoyland wanted to make the instrument smaller and easier to use by the doctors who would be purchasing it. Heterodyning of frequencies in the ray tube was a viable short cut. Bertrand Comparet, Rife’s attorney who eventually defended Dr. Rife against Philip Hoyland in the 1939 Beam Rays trial said this about Philip Hoyland’s instrument.

**COMPARET:** *“Well, none of us know enough about it. Now, I remember at that time Rife saying that Hoyland had not used a simple straight forward circuit, as Rife had used, but he thought he had a short cut, through use of harmonics and so on, and Rife had no faith in Hoyland’s circuit”.*

It is very clear that no one really knew how the Beam Rays instrument worked. Philip Hoyland did a good job of hiding the method he used. His method of heterodyning frequencies in the ray tube made it possible to build a smaller, easier to use instrument. There were no band switches or multiple coils required to produce the various frequencies.

In order for Philip Hoyland’s instrument to produce the 1,604,000 hertz frequency his fixed RF carrier frequency oscillator was set to 4,680,000 hertz (4.68 MHz) and the other variable oscillator was

set to 3,076,000 hertz. Since heterodyning frequencies produces the sum and the minus of the two frequencies being used, the minus frequency would have been 1,604,000 hertz and the sum would have been 7,756,000 hertz. Using this heterodyning method Philip Hoyland was able to build an instrument that would allow him to have a fixed carrier frequency, which would have kept the ray tube lit and made it possible to output all of Dr. Rife's frequencies. Below are photos of the spectrum analysis showing the heterodyned frequency at 1,604,000 hertz. The photo on the left is through the ray tube. The photo on the right is from a solid state circuit. The ray tube adds a great deal of harmonics be-

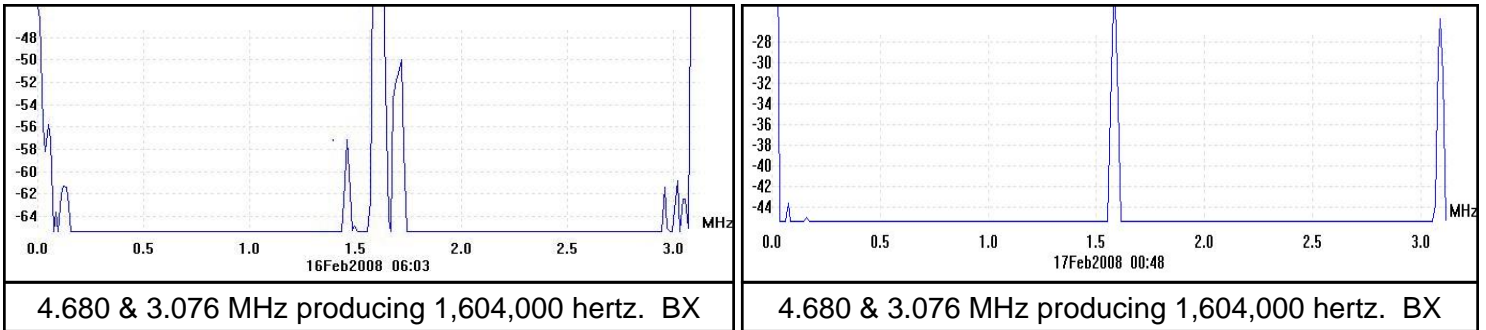

cause it distorts the sine wave. Philip Hoyland's statement that the Beam Rays instrument was not "set to the same frequencies" as Dr. Rife's instrument, was a true statement. But through the heterodyning method the Beam Rays instrument was outputting the same frequencies Dr. Rife used in the Kennedy equipment and the Rife Ray #4. Philip Hoyland's statement that he was not using Dr. Rife's frequencies was not a truthful statement because he was using Dr. Rife's frequencies in the Beam Rays instrument. He was just hiding this fact from Dr. Rife and the other men in the Beam Rays Corporation by using heterodyned frequencies. Heterodyning is not harmonics. Philip Hoyland, it appears, was only trying to hide the method he was using. Harmonics was a way of hiding what he was doing. If Philip Hoyland had told Dr. Rife he was using the heterodyning method I doubt that Dr. Rife would have objected to it. By 1935 heterodyning had been used in radio transmitters for many years. It was a viable and proven method of producing specific desired frequencies.

This method that Philip Hoyland used was a "principle fundamentally different" than what Dr. Rife originally used but it still accomplished the same goal of coordinately resonating an organism. It is easy to see that Philip Hoyland was loose with the truth. Below are more photos taken with the spectrum analyzer showing how the Beam Rays instrument could produce Dr. Rife's original RF M.O.Rs.

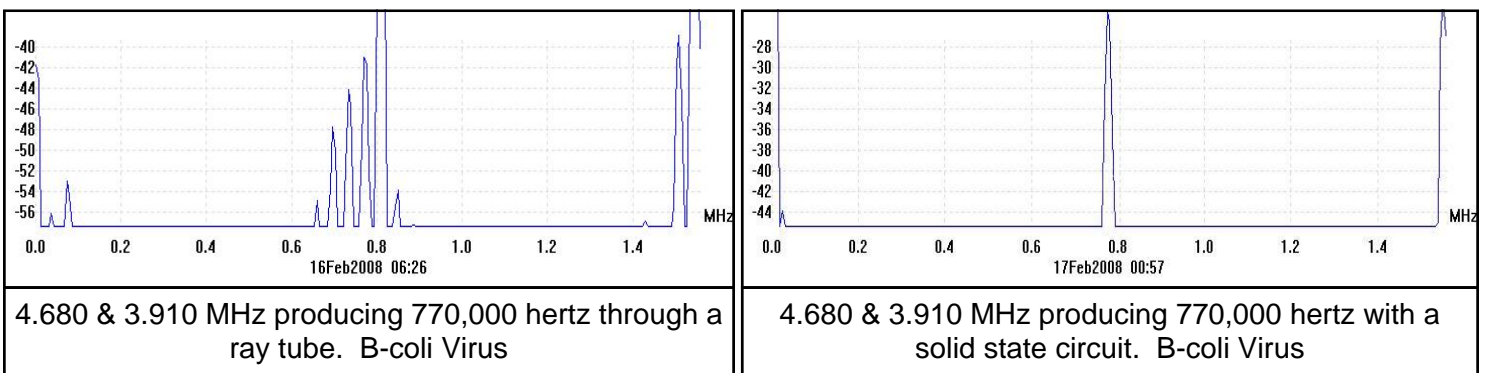
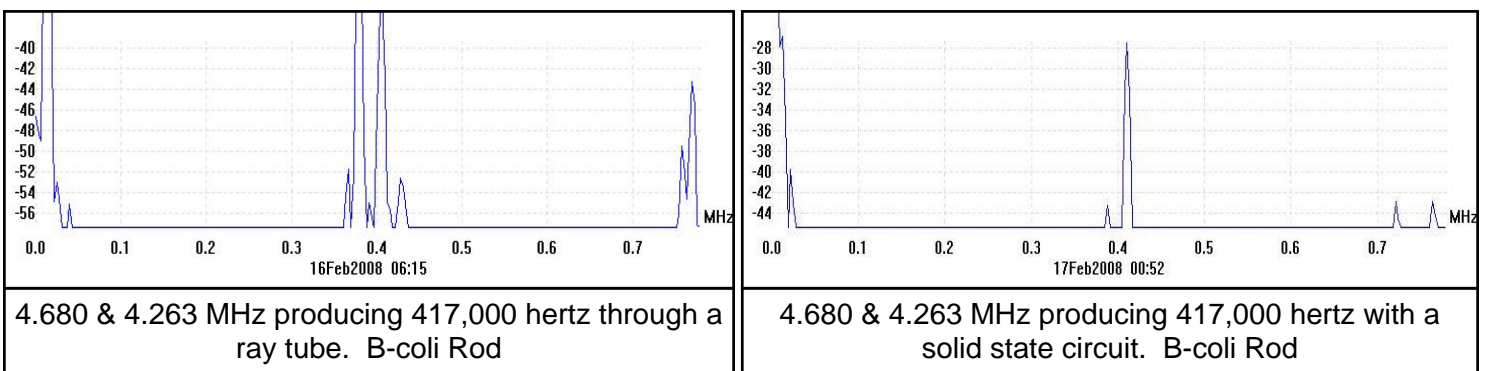

The photos on the left, on page 42, are from the ray tube. The photos on the right are from a solid state circuit. Philip Hoyland's use of a fixed RF carrier and a variable RF frequency was ingenious and made it possible to have an instrument that needed no tuning of the ray tube from 100,000 hertz to about 9,000,000 hertz.

The top photo, on the right, has the Aubrey Scoon replica and AZ-58 replica connected together. The ray tube was purchased from Bill Cheb. It is a 6 inch phanotron with the large electrodes that he normally puts in his 8 inch ray tube. You will notice that the ray tube is plugged into the positive out on each machine. Both instruments are grounded together using alligator clips. For the tests we set the Hartley Oscillator of the top instrument (Aubrey Scoon, Verne Thompson instrument) at 4.68MHz. The Hartley Oscillator of the bottom instrument (AZ-58, Verne Thomson instrument) we used as the variable oscillator. This setup works the same as the original Philip Hoyland Beam Rays instrument. Dr. Rife's #3 instrument that consisted of the Kennedy equipment output 50 watts and the #4 instrument output from 50 to about 100 watts. Both of these instruments, the AZ-58 and Aubrey Scoon's, when run separately only output about 15 watts each. But when connected together they output almost 60 watts. This shows that the original Beam Rays instrument was outputting at least 50 watts. This power level matches the power level mentioned in the documents. The tests we did revealed to us how the Beam Rays instrument worked. The fixed RF carrier section of the original Beam Rays instrument is almost identical to the 1940's Verne Thompson, Aubrey Scoon instrument and the AZ-58 instrument. The only real difference is the AZ-58 uses the 812 vacuum tube instead of the 809 tube. The 812 is more powerful.

Since the RF section of the AZ-58 is the same as the original Beam Rays instrument then all we had to do was build an AZ-58 with dual RF oscillators and we would have a Beam Rays instrument. This is exactly what we did. Jim Peters and I both have rebuilt this Beam Rays instrument. This Philip Hoyland Beam Rays instrument will not pass FCC regulations but there may be many people who will still want to build it anyway.

There is another feature that the original Beam Rays instrument had. It must have been important in order to make it work. The feature was a gating feature. If you look at the bottom photo, on the right, you will see two audio transformers. This is the only indication of any audio frequency used in the Beam Rays instrument. It is not a variable audio oscillator but is for a single fixed audio frequency. The 76 and 45 tubes along with the two audio transformers make up this circuit. Jim Peters built this section and found that the frequency was about 1330 hertz and gates the fixed Hartley Oscillator that used the 809 tube. The photo, top right, on the next page is this rebuilt circuit. This 1330 hertz frequency would wonder a little bit up or down so a gate frequency of about 1200 to 1400 hertz should work. This gate frequency is a lot faster than the eye can

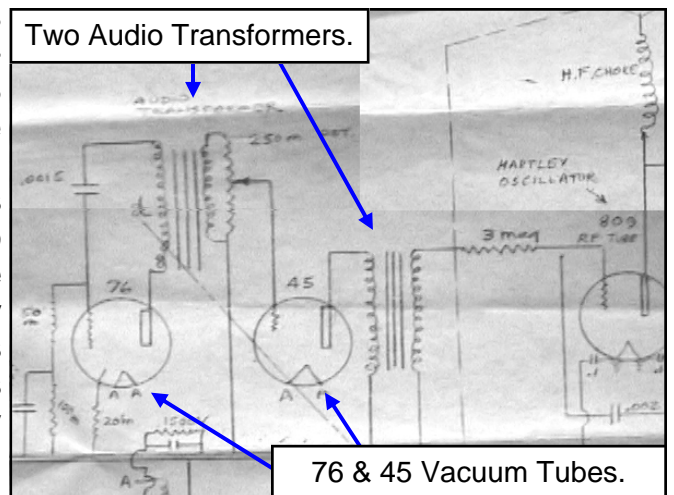

see so no one would know it was in the instrument. If you look at next photo, second down on the right, you will see the waveform of the gate frequency. It resembles a damped wave, minus the oscillations of a true damped wave. This waveform would produce the effect that John Crane mentioned as he narrated Dr. Rife's 1936 Lab video.

**Crane:** "Now the spikes that you see on the frequencies are the lethal part that kill and devitalize the virus. They are the resonant peaks of the frequencies which increase the voltage to a very high potential which the cells of the virus wall can not tolerate and they break up into many pieces and are destroyed." (Dr. Rife's Lab Film Narrated by John Crane in the 1970s)

I doubt that this understanding would have been something that John Crane would have known anything about if Dr. Rife hadn't told him about it. It appears that Dr. Rife found that having the resonant frequency of an organism is not enough to devitalize it. It appears that an organism's resonant frequency will not harm it unless the resonant frequency is gated with a waveform that produces a high potential resonant voltage spike. All of Dr. Rife's high RF frequencies were gated with this same low 1330 hertz audio frequency in the Beam Rays instrument.

There is another important effect that happens to the plasma of a ray tube when you gate it with a low audio frequency of a damped shaped waveform. Because the duty cycle is very low it allows deionization of the plasma which makes it possible for the very high potential voltage spikes to be emitted from the ray tube. A 1330 hertz square wave audio frequency of about a 20 to 25% duty cycle should be just as effective as a damped waveform. A square wave has the same high potential voltage rise on the leading edge as this damped wave.

The third photo down, on the right, is a picture of Dr. Rife's waveform from his #4 instrument. This came from his 1936 lab film. The lab film shows that he put a metal plate about 3" X 8" under the ray tube and ran his oscilloscope lead to it so he could read the frequencies. This photo shows the type of waveform he was using to devitalize organisms. It also matches the waveform produced by the 76 and 45 vacuum tubes of the original Beam Rays instrument. We believe we know from the rebuilding of this Beam Rays instrument the waveform Dr. Rife used, how he created it, and the method that should be used for doing M.O.R research.

The bottom photo, on the right, is a picture of the faceplate of the Beam Rays instrument. The dial

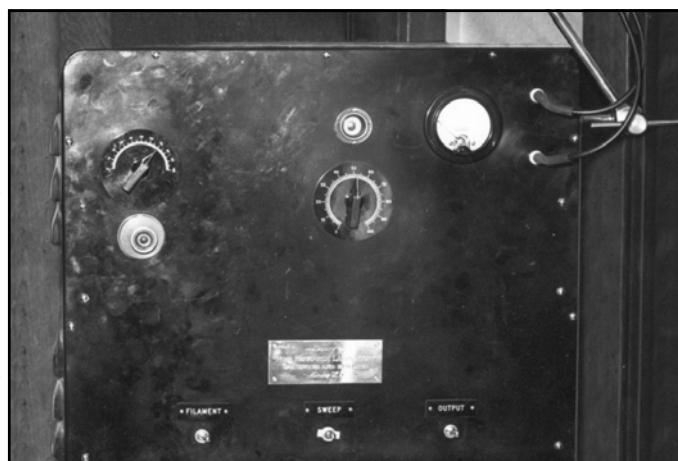
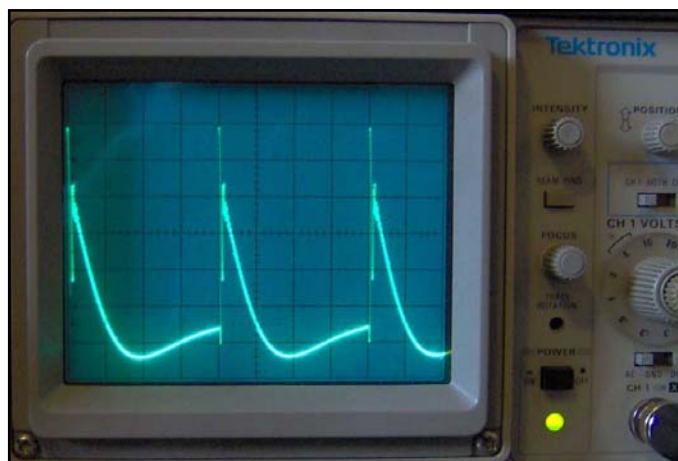

on the left is the variable Hartley Oscillator. You will notice that the dial only goes 180 degrees. Variable capacitors only tune frequencies for 180 degrees. The dial numbers go from 0 to 100. The center dial is a potentiometer and it was used to adjust the amplitude of the audio frequency gating. Potentiometers generally go almost all the way around (7 o'clock to 5 o'clock). It also has numbers from 0 to 100. You will also notice that there are no band switches which would have been necessary if the instrument used variable low audio frequencies. From rebuilding the Beam Rays instrument we can now understand why there were no band switches like the AZ-58 and the Aubrey Scoon, Verne Thompson instrument. This Beam Rays instrument was a higher RF frequency instrument. Now that we know how this instrument worked, the faceplate dials are now understandable. Below are the heterodyned frequencies that the Beam Rays instrument would have used if the fixed carrier frequency was set to 4.68 Megahertz. This was the carrier frequency used by the 1940s Aubrey Scoon, Verne Thomson instrument and the 1950s AZ-58 instrument that Verne Thompson also built. The AZ-58 documents show this carrier frequency was given as per FCC regulations. Dr. Rife and Verne Thompson would have continued to use the same carrier frequency originally granted in 1936 for the original Beam Rays instrument. Because of these facts the frequencies below would have been those used in the original 1936 to 1939 Beam Rays instrument. These frequencies would have produced the resonant frequencies which would devitalize the various organisms.

### 1938-1939 Beam Rays heterodyned frequencies

<b>Actinomycosis (Streptothrix)</b>	4,680,000 & 4,488,000 = 192,000
<b>Anthrax</b>	4,680,000 & 4,540,800 = 139,200
<b>B. Coli (Rod form)</b>	4,680,000 & 4,263,000 = 417,000
<b>B. Coli (Filterable virus)</b>	4,680,000 & 3,910,000 = 770,000
<b>Bacillus X or BX (Cancer carcinoma &amp; sarcoma)</b>	4,680,000 & 3,076,000 = 1,604,000
<b>Gonorrhea</b>	4,680,000 & 4,44,7000 = 233,000
<b>Spinal Meningitis</b>	4,680,000 & 4,253,000 = 427,000
<b>Staphylococcus Pyogenes Aureus</b>	4,680,000 & 4,202,000 = 478,000
<b>Staphylococcus Pyogenes Albus</b>	4,680,000 & 4,130,930 = 549,070
<b>Streptococcus Pyogenes</b>	4,680,000 & 3,960,000 = 720,000
<b>Syphilis</b>	4,680,000 & 3,891,000 = 789,000
<b>Tetanus</b>	4,680,000 & 4,446,000 = 234,000
<b>Tuberculosis (Rod)</b>	4,680,000 & 4,311,000 = 369,000
<b>Typhoid Fever (Rod form)</b>	4,680,000 & 3,920,000 = 760,000
<b>Typhoid Fever (Filter passing)</b>	4,680,000 & 3,235,000 = 1,445,000

After the 1939 Beam Rays trial Dr. Rife and Philip Hoyland ended their association. Dr. Rife had to get a different engineer to build and repair instruments. Dr. Rife had known Verne Thompson before he knew Philip Hoyland. Verne Thompson had been repairing Dr. Rife's equipment since the early 1930s. Verne Thompson replaced Philip Hoyland sometime around 1940. Verne Thompson built the next generation of instruments which we will discuss next.

Both Jim Peters and I rebuilt the original Beam Rays instrument. Since we are not trying to hide the second Hartley Oscillator like Philip Hoyland did it only made sense to replace the small 53 tube in the second Hartley Oscillator with an 812A tube. Jim Peters built his instrument using 805 tubes and I built my instrument using 812A tubes. The AZ-58 RF section was almost exactly the same (809 vacuum tube replaced with the more powerful 812A tube) as the original Beam Rays Circuit. The reason I built the original Beam Rays instrument using the 812A tubes is because the 809 is no longer being manufactured. We were also able to replace the fixed 1330 hertz audio section consisting of the 45 & 76 tubes with a single high voltage switching transistor driven with a function generator which outputs the 1330 hertz gate frequency. Using this transistor we believe makes the design better because we can output all the lower audio frequencies including the original audio frequencies used in the AZ-58. A variable capacitor was also added to the first Hartley Oscillator tank coil circuit so that it would be

more stable. This is why there are two Vernier dials on the front my instrument. This lack of stabilization was the biggest problem with the Beam Rays instrument back in the 1930s.

Please note that the modern Beam Rays instrument, built today, works nothing like this original 1930's Beam Rays instrument built by Philip Hoyland. We are not trying to be negative about the modern Beam Rays instrument but some have asked us if these instruments work the same and they do not. We have given this information so people are not confused about these instruments. Below and on pages 47 through 49 are the photos of the rebuilding of the original Beam Rays instrument.

### Jim Peters' photos of the newly rebuilt Beam Rays instrument

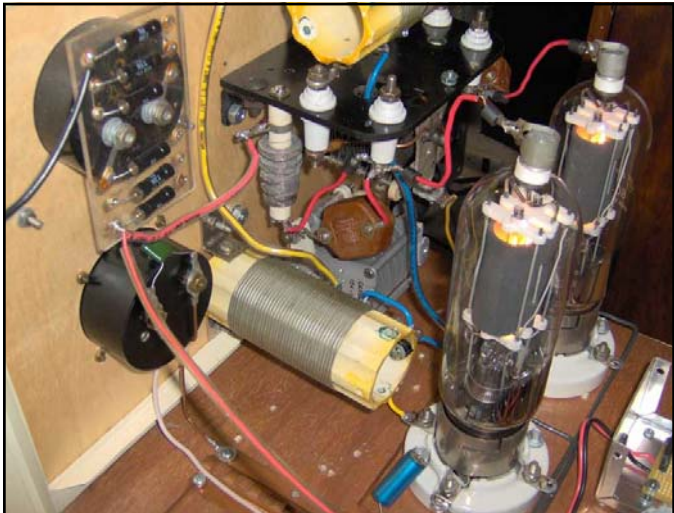
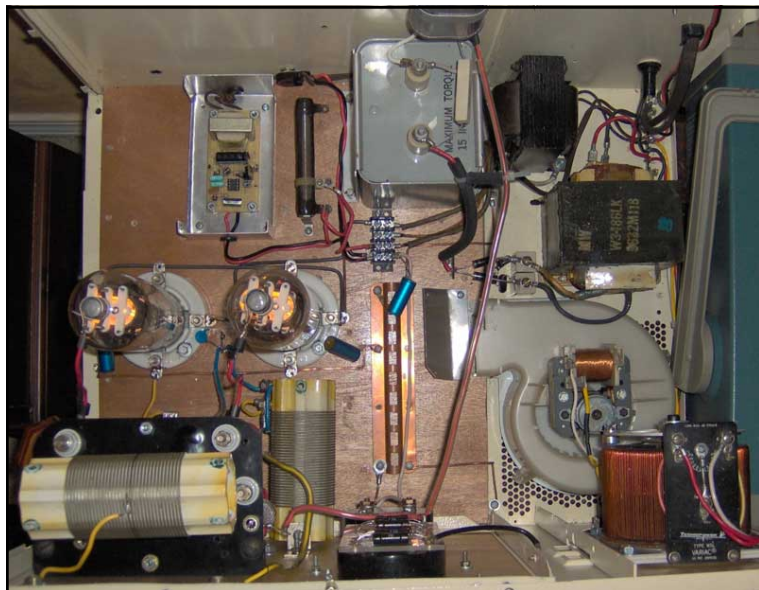

# My photos of the newly rebuilt Beam Rays instrument

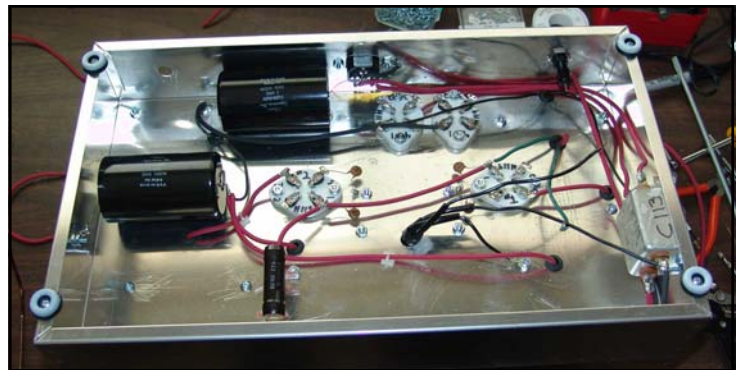
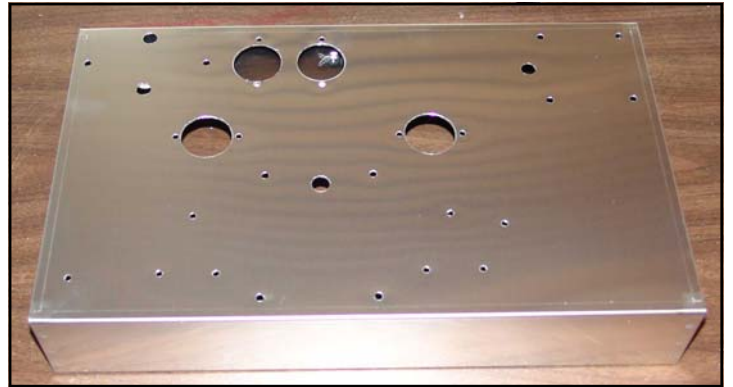

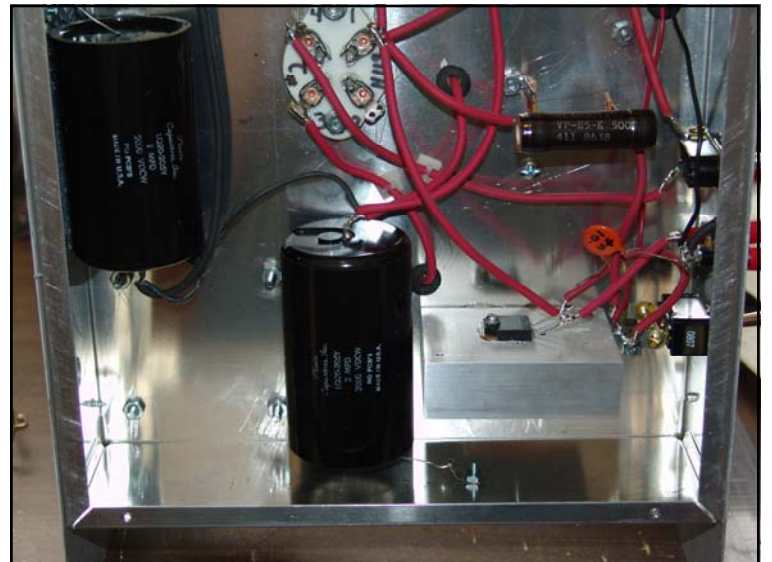
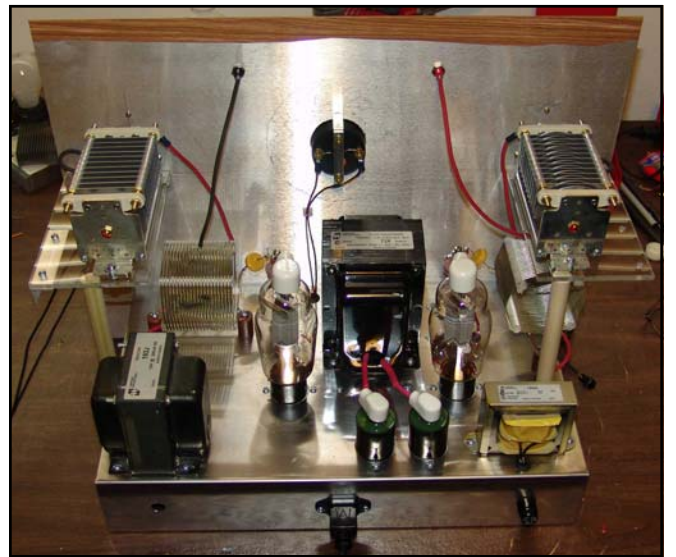
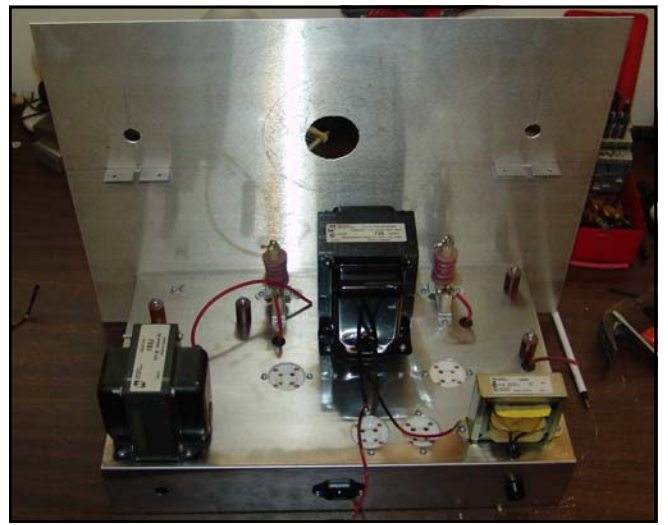



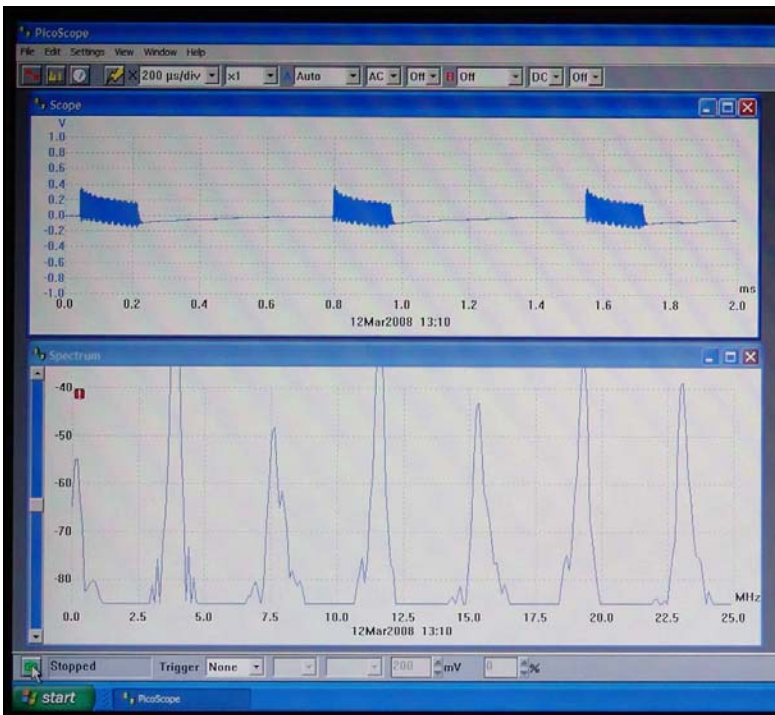
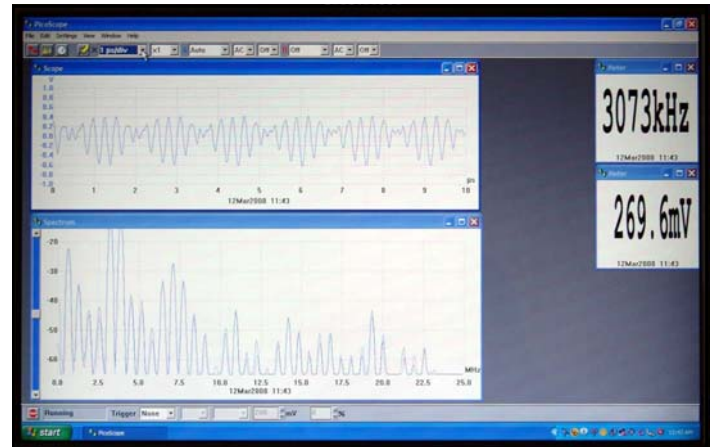
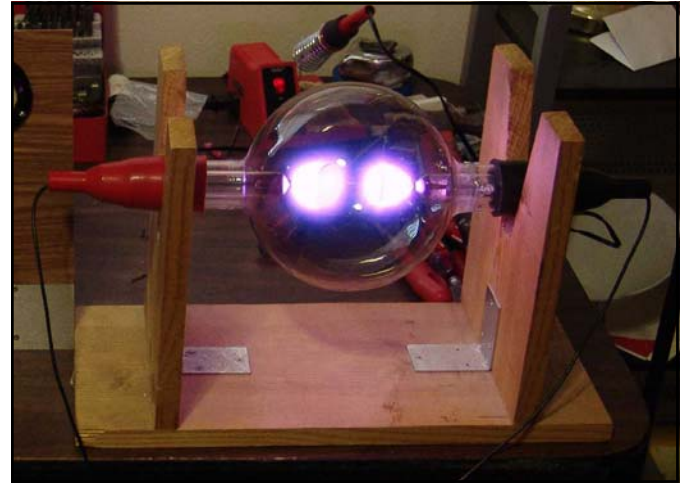
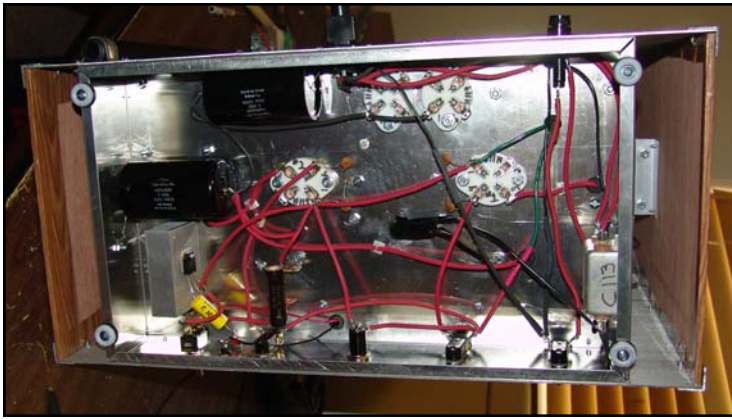

On the next page is a redrawn schematic of the original design. We replaced the smaller vacuum tube of the second Hartley Oscillator with the 809 tube. The layout of the electronic parts of this instrument is very important because of the inherent interference problems that come with RF oscillators. Anyone wishing to build this instrument should have a good understanding of old tube technology. Some parts of this circuit use up to 2000 volts DC with substantial current and can easily kill anyone not experienced in working with this kind of current or voltage. We take no responsibility for anyone who builds this instrument. We recommend that you have professional help.

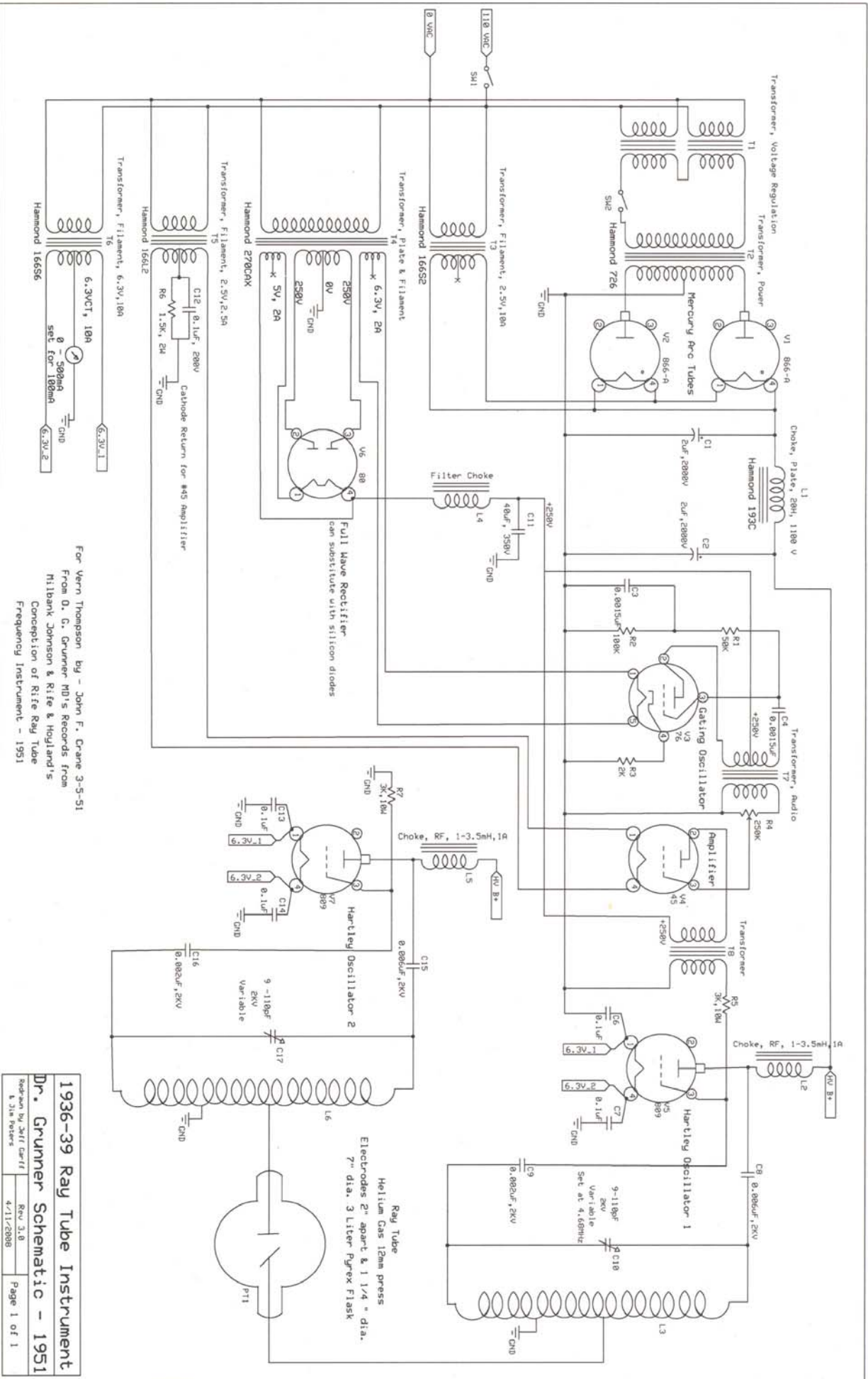

**1936-39 Ray Tube Instrument**  
**Dr. Gruner Schematic - 1951**  
 Redrawn by Jeff Carff  
 Rev 3.0  
 4/11/2008  
 Page 1 of 1

## Dr. Rife and Verne Thompson's early 1940's instrument

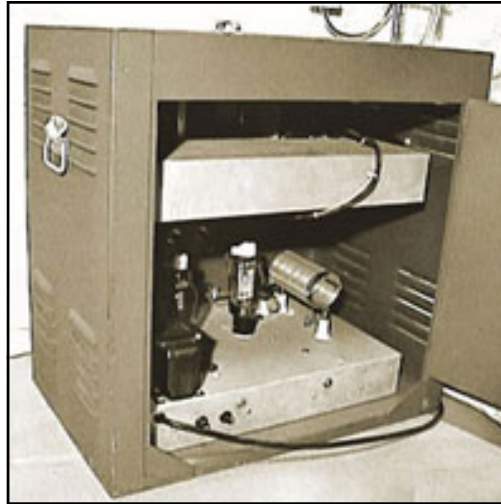

- 1) Used a ray tube.
- 2) Used 4.68 fixed carrier.
- 3) Modulated sine wave audio frequencies onto a sine wave carrier frequency.
- 4) Power usage was about 460 watts. Output to the ray tube about 15 watts.

This 1940's instrument was mistaken for a genuine 1938-1939 Beam Rays instrument built by Philip Hoyland and the Beam Rays Corporation. It was at one time for sale on [www.Rife.org](http://www.Rife.org). John Bedini and a group of men who had worked with John Crane for a year and a half considered purchasing it. After careful examination they found that this instrument was not a genuine Beam Rays instrument but in fact was built by Verne Thompson in the early 1940's (about 1942). Verne Thompson was a radio repairman who worked on police radios for the San Diego Police Department. Dr. Rife had him doing all the repairs on the instruments after Beam Rays Corporation had closed down. Verne Thompson built several machines in the 1940's. He also built the 1950's AZ-58 which Dr. Rife, John Crane and John Marsh used. Aubrey Scoon and a group of men from England purchased the above instrument believing it was a genuine Beam Rays instrument. The real Beam Rays instrument was believed to be full of harmonics. Because Aubrey Scoon's group used the wrong main output tube in repairing it the instrument had a lot of harmonics. This convinced them even further in the belief that they had a real Beam Rays instrument.

A few years ago I was communicating with Aubrey Scoon about this instrument. In the course of our communications he told me that he had used the wrong main output tube in the instrument when they fixed it. Because they had used the wrong tube the instrument had a lot of harmonics in the carrier frequency. He said that when they discovered this mistake they put the proper tube in and all the harmonics were gone. Aubrey Scoon mentions the change of this tube (809) on his web site. All of the photos of waveforms on his web site are of an instrument that is malfunctioning. This was a simple mistake, that anyone could make, but it led to a great deal of confusion causing many to believe, including myself, that this instrument was a genuine Beam Rays instrument.

Both Jim Berger and I separately built Aubrey Scoon's instrument with the correct tubes and found that the RF output was clean on an oscilloscope. This confirmed to us what Aubrey had said about using the proper tube. It also showed that it didn't have the reported harmonics (heterodyning) which the genuine Beam Rays instruments were supposed to have. This convinced us that Aubrey Scoon's instrument was not a genuine Beam Rays instrument. Nevertheless, this mistake does not lessen the importance of this instrument or the frequencies obtained from it. This instrument is very important because it predates John Crane and John Marsh and shows that the audio frequencies came from Dr. Rife and Verne Thompson, not from John Crane and John Marsh. This instrument also shows a connection to the original Beam Rays instrument and the audio frequencies that were used in the 1950's AZ-58. We will discuss this later.

It is apparent that Dr. Rife was involved in the building of this low audio frequency instrument. Dr. Rife had Verne Thompson repairing the Beam Rays instruments. It is also apparent that they removed the variable RF Hartley Oscillator since it was no longer in this instrument. The puzzling question is why would Dr. Rife and Verne Thompson even build a low audio frequency instrument when Dr. Rife's earlier high RF frequency instruments worked better? The FCC is most likely the answer. The frequencies that Dr. Rife used in his original equipment were in the AM bandwidth range. By the 1940's they would have been interfering with many radio stations. Stricter bandwidth regulations were being made to protect the airwaves. This would have meant that Dr. Rife could no longer build his original instruments without those who purchased them using a Faraday cage. This may have made it so Dr. Rife really had no choice but to build this low audio frequency instrument. Verne Thompson was making a living building and repairing radios. He would not have been willing to jeopardize his FCC license and lose his income. When one understands what really was happening in radio communications at this time it is easy to see what most likely brought about Dr. Rife's intention to modify Philip Hoyland's instrument and use it. Out of these circumstances the limited audio frequency instrument was born.

Verne Thompson must have convinced Dr. Rife that this was the direction that they needed to go. Verne Thompson took the Beam Rays instrument design and modified it to work with low audio frequencies. He kept the fixed Hartley Oscillator that used the 809 tube which produced the 4.68 MHz carrier frequency. He then modulated the low audio frequencies onto that carrier frequency. Because the audio frequencies were low enough they could easily pass the bandwidth of the tank coil. Verne Thompson then took the ray tube hookup that went to the variable RF Hartley Oscillator and grounded it to the chassis. The power of the instrument then went from about 50 watts to only 15 watts. This instrument also had the gate circuit still built into it but it was not hooked up. It appears that because the instrument was using low audio frequencies they believed it was no longer needed. Dr. Rife and Verne Thompson must have come up with these low audio frequencies. No one knows exactly what method they used to determine which audio frequencies would work with the various microorganisms.

Over the years many have tried to place the blame of using audio frequencies on John Crane. They have felt that he was the one who invented the use of them in the instruments. We now know that this is not the case. John Crane had nothing to do with the first use of audio frequencies because he didn't meet Dr. Rife until 1950. This early 1940's instrument was built before John Crane ever met Dr. Rife. To also help prove this point we will read a statement made by Dr. Rife in his 1961 deposition where he takes full credit for the use of audio frequencies in his instrument:

**RIFE:** *Initially I worked with loose couplers to get an audio oscillation and then with the use of transmitters, I tried to balance the audio and modulate the audio on a carrier wave to transmit the audio energy but I found that both the audio and the audio transmitted through a tube as an antenna worked equally as well in a painless and harmless method to human tissue.*

We know that Dr. Rife initially began his experiments using audio frequencies back in 1920. By the time the Rife Ray #4 was built in 1935 he was no longer using any audio frequencies except for the gate frequency. None of the frequencies used in the famous 1934 clinic were audio frequencies. Philip Hoyland's Beam Rays instrument didn't use any audio frequencies. By the 1940's this changed because of the new FCC regulations. I believe we finally now know where the audio frequencies came from and why they were used.

The reason all this information is being pointed out is to help make some things more understandable. The 1940's instrument built by Verne Thompson and patterned after the genuine Beam Rays instrument was changed by removing the reported harmonics (variable Hartley Oscillator which created the heterodyned frequencies) and replacing them with an variable audio frequency oscillator. This instrument never achieved the same effectiveness as Philip Hoyland's original Beam Rays instrument.

To sum things up, only a few changes were made to the original Philip Hoyland Beam Rays design in order to make this 1940's instrument. Dr. Rife and Verne Thompson kept the original Hartley

fixed RF section with the 809 tube which produced the 4.68 Megahertz carrier frequency. They replaced the variable Hartley RF oscillator with a variable audio oscillator which produced the low sine wave audio frequencies. Dr. Rife and Verne Thompson also no longer used the gate circuit which produced the damped wave waveform. When you look at both of these instrument schematics side by side it is easy to see the changes they made. These changes made it so the instrument no longer worked on a true coordinative resonance to eliminate microorganisms.

Below are Dr. Rife and Verne Thompson's low audio frequencies used in this early 1940's instrument. Both the RF carrier frequency and the low audio frequencies were sine wave waveform.

**Dr. Rife & Verne Thompson's 1940's low sine wave audio frequencies**

<b>BX (carcinoma)</b>	21275	<b>Typhoid Virus</b>	18620
<b>BY (sarcoma)</b>	20080	<b>Tetanus</b>	1200
<b>Treponema</b>	6600	<b>Typhoid Fever (rod form)</b>	6900
<b>Staphylococcus</b>	7270	<b>Pneumonia</b>	7660
<b>Streptothrix</b>	7870	<b>B. Coli (rod form)</b>	8020
<b>Tuberculosis (rod form)</b>	8300	<b>Streptococcus</b>	8450
<b>Tuberculosis (virus)</b>	16000	<b>Worms</b>	2400
<b>B. Coli (filterable virus)</b>	17220		

On the next page is a schematic of this 1940s instrument. The 866 vacuum tubes have been replaced with solid state rectifiers. Also the old vacuum tube audio oscillator has been removed. It is easier and more accurate to use Aubrey Scoon's booster amplifier and a modern function generator to produce the audio frequencies that were used in this instrument. The layout of the electronic parts of this instrument is also very important because of the inherent interference problems that come with RF oscillators. Again anyone wishing to build this instrument should have a good understanding of old tube technology. Some parts of this circuit use up to 2000 volts DC with substantial current and can easily kill anyone who is not familiar with this kind of current or voltage. We take no responsibility for anyone who builds this instrument. We recommend that you have professional help.

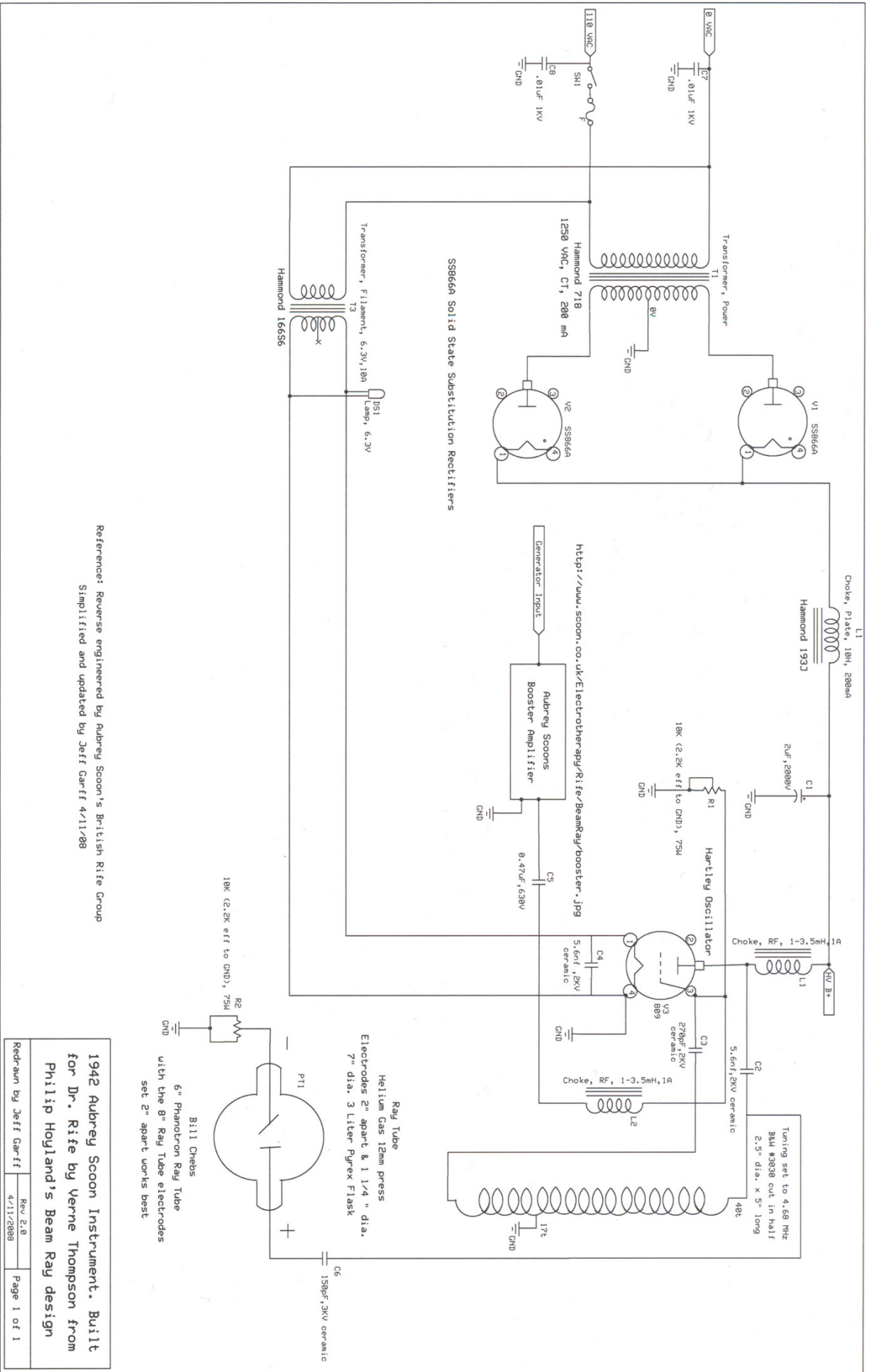

Reference: Reverse engineered by Aubrey Scoon's British Rifle Group  
Simplified and updated by Jeff Garff 4/11/2008

1942 Aubrey Scoon Instrument. Built for Dr. Rife by Verne Thompson from Philip Houjland's Beam Ray design  
Redrawn by Jeff Garff  
Rev 2.0  
4/11/2008  
Page 1 of 1

## Dr. Rife and Verne Thompson's 1950's AZ-58 ray tube instrument

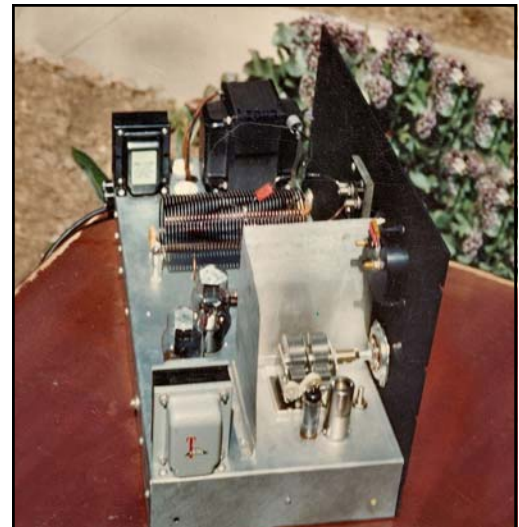
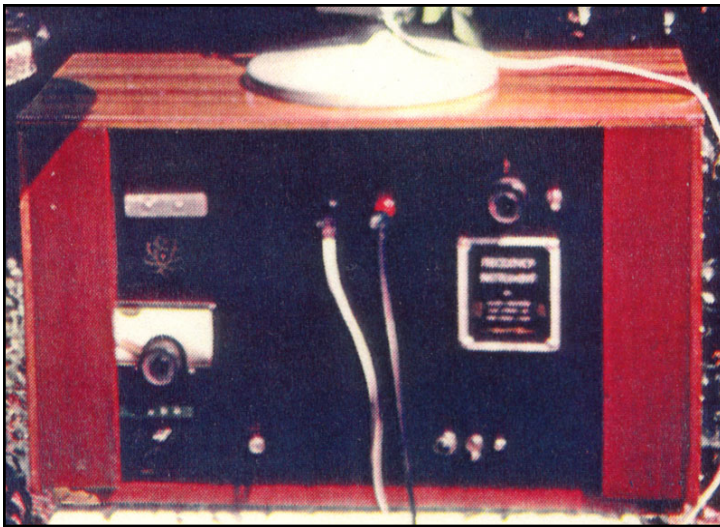

- 1) Used a ray tube.
- 2) Could change between 2.2 and 5 MHz sine wave carrier frequency (First used 4.68 carrier).
- 3) Modulated square wave audio frequencies onto the sine wave carrier frequency.
- 4) Power usage was about 460 watts. Output to the ray tube about 15 watts.

We learned that the 1950's AZ-58 design instrument began with Verne Thompson in the 1940's. We will cover this information in more depth. This style of instrument never worked as well as the Kennedy Company receivers, Rife Ray #4, or the Beam Rays instrument built by Philip Hoyland. From the stress of the Beam Rays trial, Dr. Rife became an alcoholic and all that he had worked so hard to accomplish was almost destroyed. Many of the doctors had returned their instruments because of AMA threats. All but one or two of these returned Beam Rays instruments Dr. Rife parted out and sold to anyone who wanted radio parts. Under these circumstances the Verne Thompson 1940's and AZ-58 1950's style instruments were built. The FCC began policing the airwaves and hundreds of new radio stations were being granted licenses. The RF M.O.R. frequencies which were output by the Kennedy equipment, Rife Ray #4 and Beam Rays instrument were almost all in the A.M. radio band of frequencies and would interfere with these new broadcasting stations. These events brought about the continued use of the limited audio frequency instruments.

There is one important thing I think should be said at this point. Dr. Rife at any time could have had an original Beam Rays instrument built. Dr. James B. Couche had an original Beam Rays instrument and Dr. Rife had the Gruner schematic. Dr. Rife also had the Beam Rays instrument he loaned to John Crane and John Marsh. These facts, I believe absolutely show that because of FCC regulations Dr. Rife either had to use an audio frequency instrument or no longer build one. All our investigation and the new information that we have obtained shows that Philip Hoyland's instrument didn't use audio frequencies. The FCC is the only thing that makes any sense out of what happened back in the 1940's and 1950's. The FCC regulations which caused Dr. Rife to change his instrument have impacted Rife technology in a negative way for the past 55 years. This also led almost everyone to believe that the audio frequencies used in these instruments were Dr. Rife's real M.O.R.s.

With the understanding of this information let us continue on with the history of Dr. Rife's instruments. Verne Thompson's modified Beam Rays design was also less powerful than the original Beam Rays instrument. The Beam Rays instrument output about 50 to 60 watts out of the ray tube and Verne Thompson's design only output 15 watts. This lowering of the power level came about because of the removal of the second variable Hartley Oscillator. The design of having power from two Hartley Oscillators lighting the ray tube gave the original 1930's Beam Rays instrument a power level of about 50 watts output. The early 1940's instrument used sine wave audio frequencies and this was not changed until the building of the updated 1950's AZ-58. Then the audio frequencies were changed to a square wave waveform. This is when the square wave waveform was first used.

John Crane met Dr. Rife in 1950 when he inquired about purchasing a drafting set that Dr. Rife was selling. John Marsh met John Crane in 1952 when they were both working at Convair. They both went to see Dr. Rife in 1953 to see if Dr. Rife would be willing to help with the cancer of John Marsh's wife. In Dr. Rife's 1961 deposition he said he gave John Crane his frequencies in 1950:

**COMPARET:** *"Did you ever explain to John F. Crane, one of the defendants in this case, the principles upon which your electronic frequency-generator is used in the treatment of diseases?"*

**RIFE:** *"Yes in 1950."*

**COMPARET:** *"Did you also inform him of the particular frequencies which you had found to be effective in the treatment of various diseases?"*

**RIFE:** *"Yes. Verne Thompson and I gave the frequencies to John Crane."*

**COMPARET:** *"When did you furnish him with this information?"*

**RIFE:** *"In 1950."*

The audio frequencies used in the early 1940's Aubrey Scoon, Verne Thompson instrument were about 10 times higher than those used in the 1950's AZ-58. John Crane said that the first instruments they built in 1953 didn't work very well. They would have first tried the higher audio frequencies. Apparently they didn't work very well. This is when they lowered the frequencies by a factor of 10 and changed them from sine wave to a square wave waveform. This is the first time square wave was used. John Crane said this is when the instruments started to work better. It is ironic that they had to use a square wave that produces harmonics in order to get the instrument to even begin to give them any results. Below are three photos of instruments Verne Thompson built. The first instrument, going

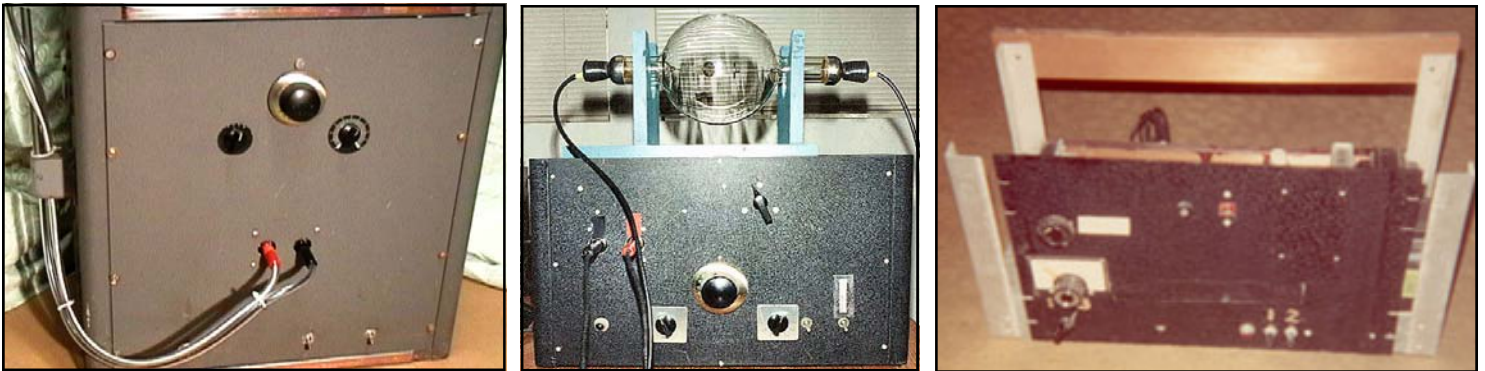

from right to left was built in the early 1940's. The second instrument is believed to have been built in the mid to late 1940's but some of the transformers are 1960's vintage which may indicate it was built in the 1950's or 60's. The audio frequencies used in it were even lower than the 1950's AZ-58. The third instrument is one of the AZ-58 instruments built by Verne Thompson in the 1950's for Dr. Rife, John Crane and John Marsh of Life Labs Co. This instrument called the AZ-58 is the most significant because we have more information about what went on in the 1950's than any period before this. At this time in the 1950's John Crane and John Marsh recorded interviews with Dr. Rife, Dr. Couche, Ben Cullen, Henry Siner and many other individuals who were key players in the early years of Dr. Rife's work.

All three of the instruments had the fixed Hartley Oscillator section. Verne Thompson changed the 809 tube to the 812 tube which gave the instrument a little more power output. All three also had one main frequency dial for adjusting the audio frequencies. The other two smaller dials were for adjusting the modulation amplitude of the audio frequencies and changing the audio frequency bands. The bands would take you through various audio frequencies. The AZ-58 was limited to about 6000



hertz but the 1940's Scoon instrument could go a lot higher in its frequency range. There is very little difference in the way these instruments work. We built two of the three, tested them, and found no significant difference other than the use of sine or square wave audio frequencies. The basic design of Philip Hoyland's Beam Rays instrument is very apparent when you compare the schematics. At any time, any one of these instruments could have been changed into a Beam Rays instrument by adding the second variable Hartley Oscillator and gating circuit. These are very simple changes to make. Six of the 1950's AZ-58 were originally built by Dr. Rife, John Crane and John Marsh. We decided to tested the AZ-58 with the spectrum analyzer. Below you can see the results of these tests.

Testing done with PicoScope 3205 spectrum analyzer at 2,400,000 Hertz using AZ-58

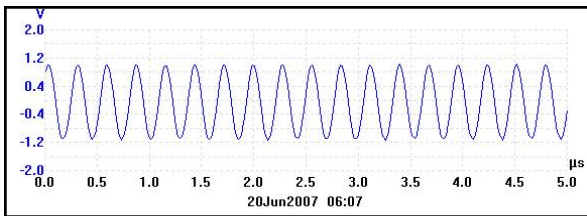

Sine wave out of AZ-58 at 2,400,000 Hertz.

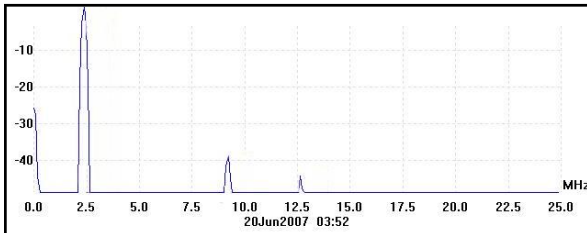

AZ-58 at 2,400,000 Hertz measured with spectrum analyzer showing no real harmonics.

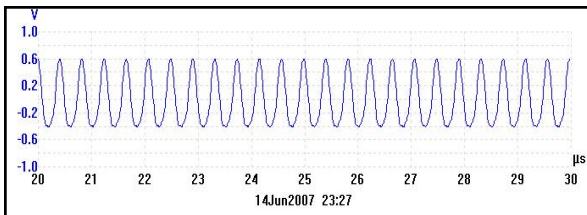

Sine wave carrier out of AZ-58 at 2,400,000 Hertz using ray tube. Sine wave carrier was always distorted when put through a ray tube.

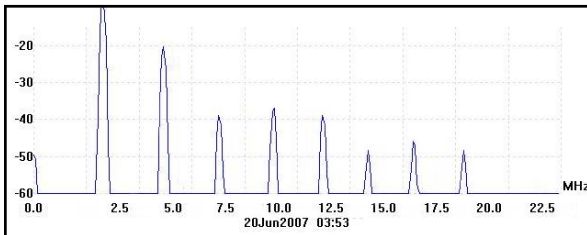

AZ-58 at 2,400,000 Hertz using ray tube. Measured with spectrum analyzer showing harmonics all the way up to 20,000,000 Hertz.

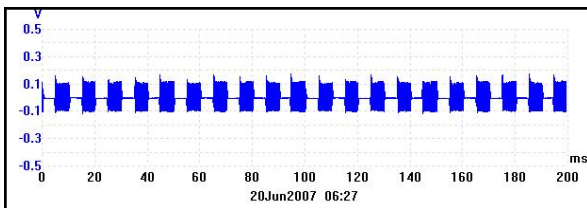

AZ-58 at 2,400,000 Hertz using ray tube. Showing 50% square wave audio frequency modulation. Square wave shows some distortion.

We will now cover in more detail the history of the instruments in the 1950's so you have a little more information. Some of the information comes from the John Marsh Collection of Rife audio CDs. As we said, in 1950 John Crane met Dr. Rife and in 1952-53 he met John Marsh. John Marsh became John Crane's supervisor at Convair Aeronautics when John Marsh moved from Tucson, Arizona to California. John Marsh's wife had cancer and they were not able to help her in Tucson so the doctors recommended that he take her to San Diego for specialized care. John Marsh and John Crane be-

came friends. John Crane told John Marsh about Dr. Rife and they then went to see him. Dr. Rife gave them an old Philip Hoyland Beam Rays instrument which they had Verne Thompson repair. John Crane and John Marsh then used this instrument on John Marsh's wife and after several treatments John Marsh said she fully recovered. Here are John Marsh's statements which he made in 1976 and 1986:

**MARSH:** (1976) *"I met this Rife. I said Dr. Rife, I said, my name is John Marsh, I've got a wife that's dying. She's got cancer of the uterus."* Dr. Rife said: *"I won't touch that thing with a 20 yard pole."* After some discussion Dr. Rife said:

**RIFE:** *"I have an old instrument down here in the basement."*

**MARSH:** *"I dug up that old instrument and of course it had tubes in it, antique stuff, and so I rebuilt the darn thing."* (John Marsh Rife CDs, CD 10 track 1)

**MARSH:** (1986) *"I went to see him [Dr. Rife], and I talked with him and he said he didn't want to have any part of it...I said look, I got a wife that's dying and I need your help! And so I got him out of his cocoon, so to speak, and we took an old instrument and rebuilt it. And I treated my wife and by darn all the pain left her and she got well."* In another part of the tape he said: *"I discovered that this Dr. Rife was a very great individual...I told John [Crane], I said look if we have any of those old instruments laying around loose, let's rejuvenate one of them and see if we can get my wife well. Well Verne Thompson who was with the San Diego police department radios, uh, radio expert, uh, had built some instruments and they were antiques when I saw them."* (John Marsh Rife CDs, CD 2 track 3)

John Marsh and John Crane then decided they would like to work with Dr. Rife and try to get the frequency instruments built and back into doctors' hands. They wanted to help people who were suffering from many incurable diseases. From earlier quotes we learned that Verne Thompson had worked on Dr. Yale's Beam Rays Corporation instruments. He knew these instruments inside and out and this is why John Marsh and John Crane had him repair the instrument that Dr. Rife gave them.

John Crane in his later years (1980's) was not very truthful and said that they had to build the first instrument without any schematics. Verne had been building this instrument for many years so John Crane's statement does not ring true. The facts have shown that this instrument design came from Philip Hoyland. It was modified and built by Verne Thompson and later updated for Dr. Rife, John Crane and John Marsh in the 1950's. Others have felt that John Crane took advantage of Dr. Rife. This may be true in some things that took place later on in the late 1960's, 1970's and 1980's but the evidence does not support this in the 1950's and early 1960's. Here is a quote from the John Marsh Collection (Trip to Ohio Papers) and Gonin Papers that are on [www.rife.org](http://www.rife.org) under the John Marsh Paperwork. Dr. Rife, John Marsh and John Crane were talking at great length about John Marsh's trip to Ohio to see Dr. Stafford. In the Gonin papers they talked about the frequencies. I would recommend that everyone read these papers because they show that Dr. Rife, John Crane and John Marsh worked as a team and John Marsh and John Crane considered the frequencies to be Dr. Rife's, and the AZ-58 instrument to be Dr. Rife's instrument. The following statements confirm this:

**RIFE:** *"Well I have lived my life for the benefit of humanity, and it is the end result of the accomplishment."*

**MARSH:** *"Yes, now here is what I did tell them. They wondered where I fit into the picture. I told them I had lay outs at the base, I designed part of it. You would say that I was possibly not an exactly an inventor, but I think we are all co-inventors of a sort by adding what we think would make the instrument better and if they try to validified (verify) any of the statements that I have said to them please don't let me down, and say no this isn't so, which might upset what might be the truth to them. I mean just by accident. Now what I mean by that is this. I don't think that I have in my own right lied to them. I did*

*[didn't] try to impress them with the idea that I was the one that did it. I did impress that you [Dr. Rife], John Crane and myself had worked together on this thing, but that you [Dr. Rife] were inventor and John [John Crane] was the designer and inventor, co-inventor and myself for putting this thing together and making it. They asked if I helped putting this thing together and making it from time to time. I couldn't tell them that I didn't, because if I had built up a feeling in them that I knew nothing about what I was doing; psychologically that could have torn down, or have caused delay the foundation that now is laid. Now I think we have a solid footing there. I under no circumstances would want that torn down, and I will not under any circumstances accept the credit for this instrument as being invented, because it is Rife's instrument as printed on the plate in front and that is one of the reasons in building you up to them, which I don't think is unwarranted; not by a darn sight, and that is why they want you there. They want to hear you talk, and they also want to know your past experiences with the people of La Jolla and also I was very happy to have received the paper concerning the Dr. etc., because I'm sure Stafford will contact every blooming Dr. that you had given him to me and I turned over all the letters to him, because I didn't want anything to stand in the way if he could contact him, now whether he would do that, before he would talk to the group, and I do not know. I suppose he will, but he wants the truth as badly as you do. Now I don't know an easier way it can be done. I don't think there is going to be an easy way to get it on, but I think I've outlined this thing. I studied the moves I was going to make before I ever went there. I studied what I was going to do if I had the opportunity to do so, which I did.*

**RIFE:** *"Well I think that you did a very excellent job."* (John Marsh Collection, Trip to Ohio Papers, Pages 4 & 5, [www.rife.org](http://www.rife.org))

And in the John Marsh Collection, Gonin Papers we read:

**CRANE:** *"So the frequencies [audio] we have written down. I will give you those or Rife will give them to you. I think you ought to have them. Each one [organism] has a different frequency, you see. I don't remember any of them off-hand. I should memorize them all, but I haven't yet. I've just written them down and they are in the lab."*

**GONIN:** *"Those frequencies that you have written down, would only apply to your own machine [AZ-58], wouldn't it?"*

**CRANE:** *"That is because they have been calibrated for each machine. Each machine has its own calibration."*

**GONIN:** *"And that's constant?"*

**CRANE:** *"Yes."* (John Marsh Collection, Gonin and Siner Papers, Page 15, [www.rife.org](http://www.rife.org))

After reading these documents the facts stand out that all three of these men knew the audio frequencies and they were not John Crane's invention. Both John Marsh and John Crane considered the instrument to be Dr. Rife's. Dr. Rife also had a plaque on the front of the instrument with his name on it. It is also clear from John Marsh's papers that Dr. Rife was not on the sidelines but was a working partner in Life Labs. Dr. Rife by this time had become what some people call a working alcoholic. This type of drinker would have a little to drink during the day to take the edge off but would not be a total drunk. Dr. Rife knew how the instrument worked and knew the audio frequencies that were used in it.

In the Rife CD's all of Dr. Rife's recorded conversations were very positive about the instrument and this does not sound like a man who was ignorant of what was going on as some have claimed. When Dr. Rife was asked about his frequencies in about 1957 he said that they were from the audio band to the broadcast band of frequencies. This tells us that he was still reserving his final decision about the audio frequencies they were using until after the instrument was fully tested. He had seen what Philip Hoyland's original instrument could do in the 1930s. But the AZ-58 had been updated from

the earlier 1940's instrument. Dr. Rife said he never fooled himself and I don't believe that he did on this AZ-58 instrument. Anyone who reads the documents from this period of time can tell that there were a lot of high hopes for this instrument and the lower audio frequencies it was using. Now the real question is how well did this instrument work after they updated it? There were a lot of good reports on how well the instrument worked but what really counts is how well it worked in the hands of the doctors who used it on their patients. Dr. Robert P. Stafford M.D., used the AZ-58 for 5 years on his patients. His report is on [www.rife.org](http://www.rife.org) with the John Marsh documents. His report is very favorable on many conditions that he used it for but when it came to cancer this instrument did not work as well as Philip Hoyland's instrument that used Dr. Rife's high RF frequencies. Dr. Stafford's report showed he treated 16 cancer patients and had a 100% failure rate using the AZ-58 on cancer. We must say that the instrument did help some of his cancer patients while others did not see any benefits. Two of the women that he treated received a great deal of benefit but died from other complications. Dr. Stafford said this about the AZ-58 audio frequency instrument:

**DR. STAFFORD:** *"As yet, we have failed to "cure" any case of advanced, terminal malignancy. It appears in several instances that we may have impressed the disease favorably, temporarily. It is difficult to rule out the psychological, morale booster effect to the terminal patient when some definitive effort is made again in his behalf. However, several improvements have appeared to be more physical than emotional...All the patients in the series were treated with the same frequencies (e.g., 728 - 784 - 880 - 2008 - 2128). Perhaps these frequencies may be wrong, or only nearly correct."* (John Marsh Collection, Dr. Stafford's Report on using the AZ-58, [www.rife.org](http://www.rife.org))

Everyone who has been around Rife technology for a long time has seen the very same results as Dr. Stafford. Today these frequencies 728, 784, 880, 2008 and 2128 are used by just about everyone for cancer. As mentioned earlier, almost everyone believes they are Dr. Rife's true M.O.R. frequencies. But they are not. It must be remembered that there is about a 35% placebo effect in whatever human medical test is done. This can fool almost anyone if they are not careful. Dr. Stafford followed these 16 people over many years and in some cases things looked good at first, but the people eventually died from their cancer anyway. In the 1934 clinic 16 patients who had cancer and tuberculosis were treated and cured. This is quite a contrast; 100% success in 1934 using Dr. Rife's high RF frequencies and 100% failure on cancer for low audio frequencies for the five years Dr. Stafford used the AZ-58 instrument. Dr. Stafford sent his report to John Marsh. I am sure John Crane received it also. The big question that needs to be asked is, why did John Crane and John Marsh continue to tell people these audio frequencies were the frequencies which Dr. Rife used in the 1934 clinic when the medical proof showed they didn't work as well as high RF frequencies? And why do people today continue to say these frequencies cure cancer even after they have seen the same results? Could it be because having had a few good results which most likely fell under the placebo effect, they ignored the evidence and fooled themselves? By the time all the evidence was available, John Marsh and John Crane were in jail on three or four different legal counts, one of which was for treating a woman. Dr. Rife did not want to have anything to do with all the legal trouble they were in. He was able to avoid it because he never made any claims and he would never treat anyone. The legal problems shut down Life Labs. Had this not happened I wonder if Dr. Rife would have ignored this evidence? I do not believe he would have. He would have realized that the changes they made to the instrument and the use of audio frequencies compromised its effectiveness. I think he would have gone back to his original principles of using high RF frequencies and just built a Faraday cage. We will never know what he would have done because I do not think Dr. Rife ever read Dr. Stafford's report because John Marsh received it after he and John Crane got out of jail.

The sad thing is this, because so few really understand Dr. Rife's early instruments a whole industry has been built on this limited audio frequency instrument. The people who purchase these audio frequency instruments believe it is the same type of instrument used in the 1934 clinic. All because we didn't know the truth. Are we today just fooling ourselves also? Are we trying to get these same audio type instruments and the frequencies they use to do what Dr. Stafford could not get them to do?

Cure cancer? We know there have been incredibly good results on many other conditions using audio frequencies which show this type of instrument is of great worth but the truth is sometimes hard to accept.

As we have already read, Dr. Stafford came to suspect that the audio frequencies were not true M.O.R.s and he wrote a letter to Dr. Edward Jeppson in Salt Lake City because Dr. Jeppson was having the same type of results Dr. Stafford was having. Here is his statement from his letter:

**DR. STAFFORD:** *“Please excuse my format in the following letter for I intend to ramble a bit and forget strict grammatical dictum. I am writing you at this time partially because John Marsh informs me in a recent letter that you may be somewhat disheartened or at least worried about your role in the experimentations with the Rife Machine. Believe me, Dr. Edward I know how you feel for I too have been through this same feeling with this matter. I have observed clinical results after treatments with this gadget which I can scarcely believe myself. Yet, despite these good results, I have been confused by some rather simple failures such as a recent experiment which I conducted at Good Samaritan Hospital where we used the machine to treat some cultures of Staph Aureus and Strept. Fecalis. In this work we failed to inhibit growth at all or influence the cultures with the Rife Rx. I sent the results to John Marsh and asked for clarification and to be very frank I am not satisfied with John’s excuse of the failure as described by Dr. Rife. I am afraid I’m not a very good apostle for I’m getting some ideas myself on how this thing may work. I really wonder if this ultrasonic kills bacteria and virus at all or does it work like other forms of ultrasonic and merely stimulate the tissue in some unusual manner thereby improving the circulation and secondarily enhancing the body’s defenses against infection...To summarize some of this rambling: I feel that the Rife Ultrasonic Therapy has a very definitely beneficial effect on the human (and canine) body...I furthermore feel that we, as doctors of medicine, using this machine must remain constantly alert to the condition of our patient and vary the Rx as indicated.”*

Clearly Dr. Stafford didn’t believe the audio frequencies were correct. Little did he know they were not the same frequencies used with the Beam Rays, Rife Ray #4 and Kennedy Company equipment. The AZ-58 could not output these frequencies. Whatever was told to Dr. Stafford by Dr. Rife through John Marsh there was no way they were going to tell Dr. Stafford he wasn’t using the correct high RF frequencies. This would ruin everything they had worked for. Besides they really had no choice because of the FCC regulations. We must remember they were testing the AZ-58 to see how well it would work using just audio frequencies with a fixed RF carrier frequency. At this time it is apparent the AZ-58 was not performing as well as Philip Hoyland’s Beam Rays instrument, Rife Ray #4 and Kennedy Company equipment. We need to remember Philip Hoyland tested his instrument using Dr. Rife’s microscope. When Henry Siner was in England testing Philip Hoyland’s instrument he reported that it would kill the organisms while they were looking at them under Dr. Rife’s microscope. These facts show that Philip Hoyland’s Beam Rays instrument was working on Dr. Rife’s same principle of coordinative resonance. Dr. Stafford found out the AZ-58 was not capable of doing this when he tested it on microorganisms. In the 1950’s Dr. Rife no longer had a lab for testing any microorganisms. There is no evidence they ever tested just the audio frequencies with the microscope. So they did the only thing they could. They let the doctors use the AZ-58 and tell them how well it worked. We must remember the instrument Dr. Rife gave to John Marsh and John Crane was Philip Hoyland’s Beam Rays instrument and it worked. John Marsh said it cured his wife of cancer. Again the fact is the Dr. Rife, Verne Thompson 1940’s and 1950’s AZ-58 instrument never worked as well as Philip Hoyland’s Beam Rays instrument, Rife Ray #4 or Kennedy Company instruments. The changes made to the AZ-58 produced very good results but not on cancer. But still even with the changes the AZ-58 worked very well on just about everything else but cancer. These square wave audio frequencies are what people have been using for the past 50 years believing they were Dr. Rife’s true M.O.R.s, all the while not knowing they were not Dr. Rife’s original frequencies which he used in his earlier instruments built in the 1920’s and 1930’s. Not until the Papers from the 1939 Beam Rays Trial, John Marsh Papers, Kennedy Company equipment spectrum analysis and Philip Hoyland Beam Rays spectrum analysis came to light did we have the ability to finally figure out where all these frequencies came

from, or which frequencies were the correct M.O.R.s. Notwithstanding the various setbacks Dr. Stafford was still amazed at the wonderful results he achieved with the AZ-58.

To sum things up only a few changes were made to the 1940's instrument which produced the 1950's AZ-58. Dr. Rife and Verne Thompson kept the original Hartley 4.68 Megahertz fixed RF carrier frequency section but changed the 809 tube to the 812 tube. They kept the variable audio oscillator which produced the low sine wave audio frequencies but lowered its range of frequencies. The AZ-58 only had a top audio frequency range of 6000 hertz. Dr. Rife and Verne Thompson then lowered the 1940's audio frequencies by a factor of about 10 times and used these lower audio frequencies in the AZ-58. They then changed the audio frequency waveform from sine wave to square wave. They also no longer used the gate circuit which produced the damped wave waveform. It is interesting that the square wave waveform would create the same kind of high potential voltage spike in the frequencies that the damped wave gate frequency did. When you compare the 1940's instrument to the 1950's AZ-58 they are almost identical. When we built both of these instruments and compared them we found the AZ-58 appears to be the better design since it is a little more powerful. The 812 tube is more powerful than the 809 tube.

Below is a list of Dr. Rife and Verne Thompson's lower square wave audio frequencies used by Dr. Stafford in the AZ-58 instrument. The AZ-58 also no longer worked on a true coordinative resonance to eliminate microorganisms.

**Dr. Rife & Verne Thompson's 1950's square wave audio frequencies**

<b>BX (carcinoma)</b>	2128	<b>Typhoid Virus</b>	1862	<b>Streptococcus</b>	880
<b>BY (sarcoma)</b>	2008	<b>Tetanus</b>	120	<b>Gonorrhea</b>	712
<b>Treponema (syphilis)</b>	660	<b>Typhoid Fever (rod form)</b>	712		
<b>Staphylococcus</b>	727	<b>Pneumonia</b>	776		
<b>Streptothrix</b>	784	<b>B. Coli (rod form)</b>	800		
<b>Tuberculosis (rod form)</b>	803	<b>B. Coli (filterable virus)</b>	1552		
<b>Tuberculosis Virus</b>	1552				

On the next page is a schematic of the 1950s AZ-58 instrument. The 866 vacuum tubes have been replaced with solid state rectifiers. Also the old vacuum tube audio oscillator has been removed. It is easier and more accurate to use Aubrey Scoon's booster amplifier and a modern function generator to produce the audio frequencies that were used in this instrument. The layout of the electronic parts of this instrument is also very important because of the inherent interference problems that come with RF oscillators. Again anyone wishing to build this instrument should have a good understanding of old tube technology. Some parts of this circuit use up to 2000 volts DC with substantial current and can easily kill anyone who is not familiar with this kind of current or voltage. We take no responsibility for anyone who builds this instrument. We recommend that you have professional help.

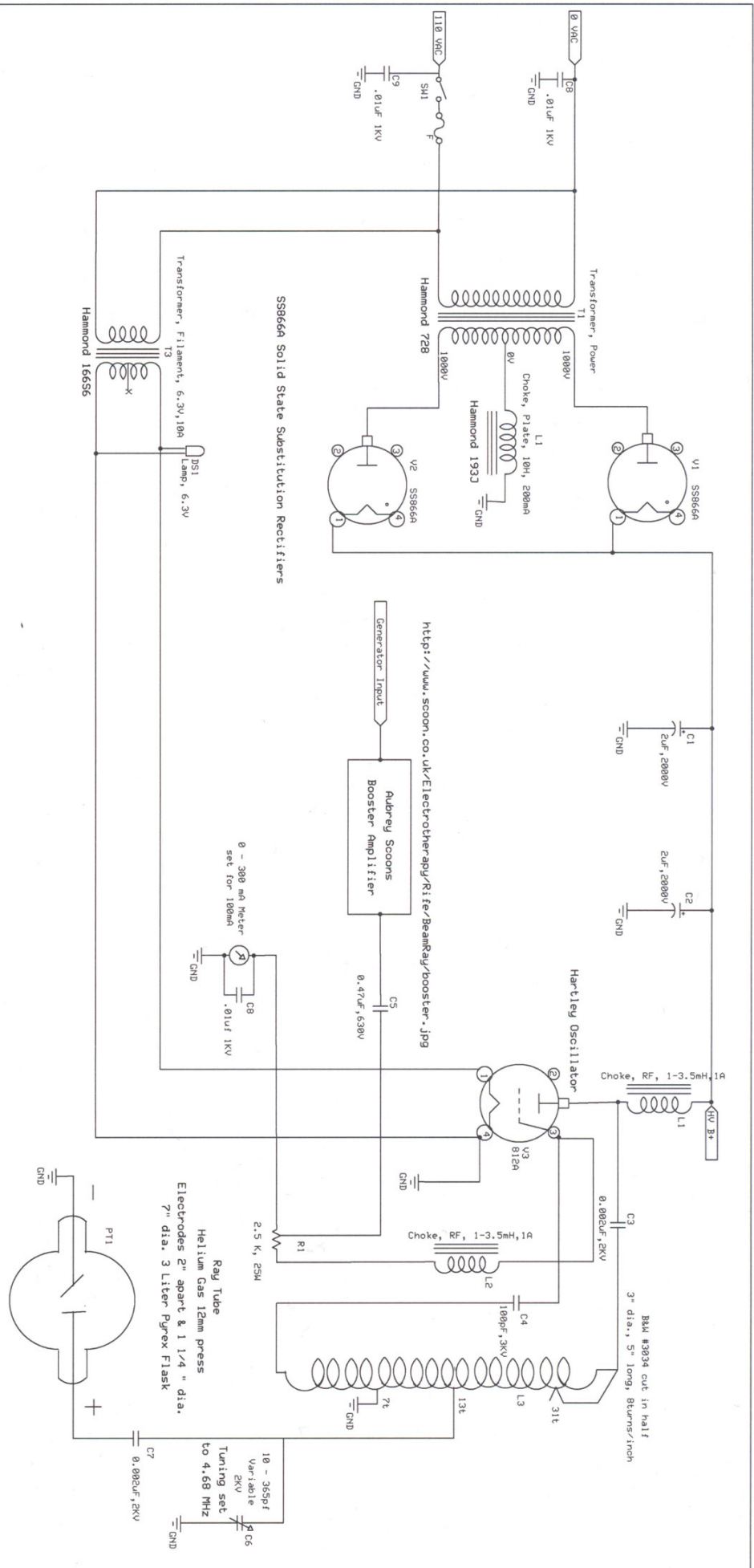

Reference: Allied Industries, John Crane, 08/08/56  
 Schematic Corrected by James Cunningham 03/2000  
 Simplified and updated by Jeff Garff and Jim Peters 4/11/08

**1950s A2-58 Instrument. Built for  
 Dr. Rife by Verne Thompson from  
 Philip Hogland's Beam Ray design**

Redrawn by Jeff Garff  
 Rev 2.0  
 4/11/2008  
 Page 1 of 1

## Harmonic audio frequency myth?

There is a belief that the audio frequencies that were used in the 1940's and 1950's audio frequency instruments are harmonic frequencies derived by dividing Dr. Rife's original high RF frequencies down in octave steps until you reach the audio range of frequencies. For this to be true all of the audio frequencies would have to be true harmonics of the higher RF frequencies. This is not the case.

All the documents we have quoted and the understanding we now have prove as a myth the long believed concept that the audio frequencies used in the 1950's were created by John Crane and John Marsh by dividing Dr. Rife's high frequency M.O.R.s down by harmonic steps until they reached the audio range of frequencies. If we take the correct frequency for the BX of 1,604,000 Hertz read by Philip Hoyland and divide it down by harmonics we do not get 2008 or 2128. In fact, we do not get the higher 1940's audio frequencies of 20080 or 21275 Hertz either. This clearly proves John Crane and John Marsh did not create the audio frequencies by just dividing down Dr. Rife's higher RF M.O.R. frequencies. The fact is we really do not know how Dr. Rife and Verne Thompson came up with these audio frequencies. This is probably the last mystery that needs to be solved.

The documented information we have shows that Dr. Rife's true M.O.R.s that would resonate organisms were the higher RF frequencies used in the Kennedy Models 110, 281 and Rife Ray #4 and 1930's Beam Rays instrument. From the spectrum analysis of Philip Hoyland's Beam Rays instrument we know that it used the method of heterodyning to produce the high RF M.O.R.s. Henry Siner reported Philip Hoyland's design killed the organisms under microscope observation. Dr. Stafford was not able to kill any organisms using just the audio frequencies with a fixed RF carrier. He did his tests under microscope observation. Today, like Dr. Stafford many have tried to kill the organisms which these audio frequencies correspond to, with no success. If these audio frequencies, as some have claimed, were really harmonic frequencies derived from the higher RF M.O.R. frequencies then they should be able to kill the microorganism they correspond to. If an audio frequency harmonic of Dr. Rife's RF M.O.R. will not devitalize an organism under microscope observation, can the harmonic association be valid? No rational person would believe this. Yet today this is exactly what most people believe because they do not have all of the facts. The evidence we have read shows that if the RF M.O.R. frequency is lowered by too much it will lose its ability to devitalize an organism even though it is a harmonic frequency. Dr. Stafford and many others found when they treated the organism with the audio frequency that was supposed to devitalize it the organism continued to grow. Then when they transferred it from one culture to another it still grew on the new medium they used. Can there be any greater scientific proof than this? Even Dr. Rife would not have argue with this method of determining true M.O.R.s because this is the method he used. This is the greatest proof, along with the fact that almost all the audio frequencies are not true harmonics of the original high RF frequencies. We know many other people who have made the same tests as Dr. Stafford and told us they obtained the same results he did. John Marsh said on the Rife CDs that they came up with the frequencies using math. If every audio frequency was a perfect harmonic match to its higher RF M.O.R. then we could say they were all derived from the RF M.O.R.s. But they are not. Even if the audio frequencies were derived from the RF M.O.R.s and do not devitalize the organism in the same way is the principle valid?

What the evidence certainly proves is, without really knowing it, Dr. Rife, John Crane and John Marsh discovered that these lower square wave audio frequencies are beneficial. Since they will not devitalize an organism under microscope observation, then how can it be that they seem to help people? From Dr. Stafford's statement we read that he also wondered why they would work on some conditions and not others, like cancer. He felt that these audio frequencies stimulated the adrenal glands and immune system much like ultrasonic frequencies do. And this stimulation is why the frequencies help even though they do not work like a true RF M.O.R. frequency would. The fact is we really don't know why the audio frequencies are beneficial, but for some unknown reason they are. Though the method of modulating an audio frequency onto a fixed carrier did not work as well as Dr. Rife's original method did, nevertheless it works very well on some conditions. Even though the audio frequencies are beneficial in many ways, this still does not prove the myth that the 1950's audio frequencies are harmonic M.O.R.s.



## Labs1950's pad instrument (without ray tube)

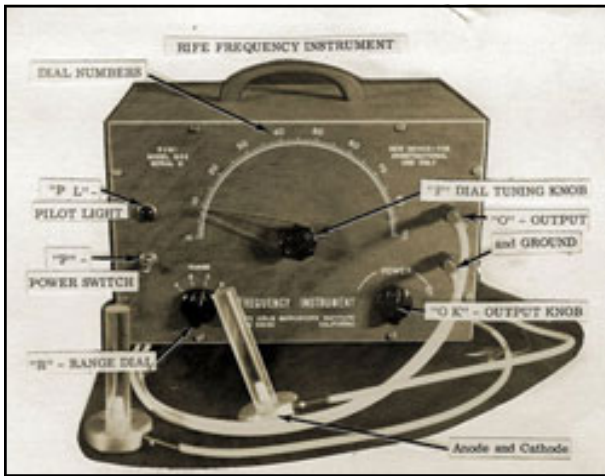

- 1) Used round disks that came in contact with the body. Later changed in the 1960's to hand cylinders or foot pads.
- 2) Had no RF carrier frequency.
- 3) Used the square wave audio frequencies used in the AZ-58.

It was about 1957 when John Crane and John Marsh began building instruments without a ray tube. Earlier in this article Bertrand Comparet was quoted as saying:

**COMPARET:** *"Now, Crane said "Well now look, Rife himself admits that no matter how much tube and ray, and so on, you have, you can't get any results unless you've got the right frequency. Therefore the real clue to the thing is the frequency and not the means by which you deliver it."* (Comparet Interview papers - 1970's)

John Crane and John Marsh replaced the ray tube with a type of pad that they developed which came in contact with the body. As we pointed out earlier in this article it is interesting to note that Dr. Rife said Abrams' Oscilloclast would devitalize the BX cancer virus and it was a contact type device. John Crane and John Marsh probably used this contact method because of the success of Abrams' instrument. From the documented information we have it was also the high cost of building ray tube instruments that caused them to look at doing things in a different way. In addition to being expensive to build, the ray tube could break very easily. They had many problems with them. I don't believe Dr. Rife, at least in his early years, ever had a reason to look at doing things differently. John Crane and John Marsh did! They didn't have the kind of money to spend that Dr. Rife did. Necessity is the mother of invention!

John Crane and John Marsh used a Heathkit function generator to produce the frequencies. These Heathkit function generators had no built-in carrier frequency on which to modulate the audio frequencies. Therefore, the carrier frequency was no longer used. Though John Crane and John Marsh achieved great results with these instruments, they did not use a carrier frequency. What would have been the results if they had used these audio frequencies with a carrier frequency? From what we have previously discussed in this article, the carrier frequency was very important. Dr. Rife would never have approved using an instrument without a carrier. The positive part of using a Heathkit function generator in this way was that they were inexpensive (\$200) and a lot more people could afford one. Many people can thank John Crane and John Marsh for this innovative method. John Crane and John Marsh proved that the audio frequencies worked the same whether applied through a ray tube or pads if sufficient power is used. Many people think that John Crane and John Marsh built the pad instrument without Dr. Rife being fully informed about it. But this was not the case. In John Marsh's Trip to Ohio Papers we read this:

**RIFE**: *“That is the only way that it can be handled properly.”*

**MARSH**: *“Maybe we can sell small instruments for the purpose of small diseases like colds, flu and stuff like that, which are minor, which the Dr.s prefer not treating those kind anyway, because they are chronic, and there isn't anything they can do with them. People keep coming in and coming in and they take up his time where he could spend it taking care of a bad case, or something or other. Dr. Stafford said that he would prefer that a small instrument would be made...What do you think John? I've been doing a lot of talking not even giving you a chance to get a word in edgewise.”*

**CRANE**: *“There is no doubt there is going to be an awful lot of development on this design...”* John Marsh collection - Trip to Ohio papers page 10. [www.rife.org](http://www.rife.org))

From these statements we learn that Dr. Rife knew that they wanted to build small instruments. Also we learn that it was John Marsh and John Crane's idea to build the pad instruments and not Dr. Rife's. We know that Dr. Rife was upset with John Crane over some of his changes because he expressed it to Comparet during his 1961 deposition. Comparet said:

**COMPARET**: *“And I asked Rife, because I thought Rife would certainly say that the way Crane was working on it then was still using the Rife principle, but he indignantly denied it.”* (Comparet interview papers - 1970's)

At this time John Crane and John Marsh were working on both the ray tube instrument and the pad instrument. We know that Dr. Rife considered the ray tube instrument to be his. This ray tube instrument used an RF carrier frequency on which the audio frequencies were modulated. It must have been the pad instruments without a carrier frequency that Dr. Rife was upset with. However, John Marsh and John Crane's innovation with a pad instrument did prove that the ray tube could be removed. This made it possible for more people to have access to Dr. Rife's technology. Today all the frequencies which Dr. Rife used can be produced by any function generator with the proper frequency range.

This appears to be the reason why John Crane and John Marsh didn't use a carrier frequency. The Heathkit function generator that they used didn't have the capability of using a Megahertz (MHz) carrier frequency. Audio frequencies will not broadcast, therefore, they are modulated upon the carrier frequency so that they will penetrate the body. In laymen's terms, modulation is piggy-backing one or more low frequencies on another higher frequency. The frequencies travel together but still remain somewhat separate and distinct. Many instruments built today do not use a carrier frequency even though Dr. Rife's did. If Dr. Rife could have removed the carrier frequencies from his instrument and gotten the same results, I believe he would have. As it is, Dr. Rife never removed the carrier frequency from any of his instruments. It was John Crane and John Marsh who did this. If a person wants to try and obtain the results which Dr. Rife did, then a carrier frequency should be considered and used in any audio frequency instrument.

We realize that there are ray tube instruments today that do not use a carrier frequency. These use a high electromagnetic field which will transfer the energy into the body. They appear to work very well. We do not doubt that these instruments work. We know people that are using these instruments and getting very good results. But what we are talking about in this article is the way that Dr. Rife used RF frequencies and an RF carrier frequency modulated with an audio frequency.

Some people say that audio frequencies in a pad instrument without a carrier will only travel along the skin of the body and won't penetrate it. In scientific studies on Bioelectric Impedance Analysis in the body it has been shown that sine wave audio frequencies will enter the body but will only travel in the connective tissues around the cells. Also in these scientific studies it has been shown that the closer you get to 1 Megahertz the greater the penetration into the cell. At 1 Megahertz the frequency will go straight through the cell and fully penetrate the body. This is why it is very important that a carrier frequency be used. A virus can enter a cell. An RF frequency can enter the cell where it can

do the most good. These kinds of scientific studies and their importance were not understood by John Crane and John Marsh in the 1950's and 1960's. Dr. Rife's instruments always used a carrier frequency.

Below is a schematic of John Crane & John Marsh's pad instrument. It was nothing more than an off-the-shelf audio frequency generator with the faceplate changed. There was nothing special about this frequency generator because any common function generator can do the same thing this one could. There have been people who have copied this instrument and who charge enormous sums of money for a replica. As much as four or five thousand dollars. They claim that this is a real genuine Rife Machine. Do not be fooled. The same audio frequencies that were used in the AZ-58 were used with this instrument.

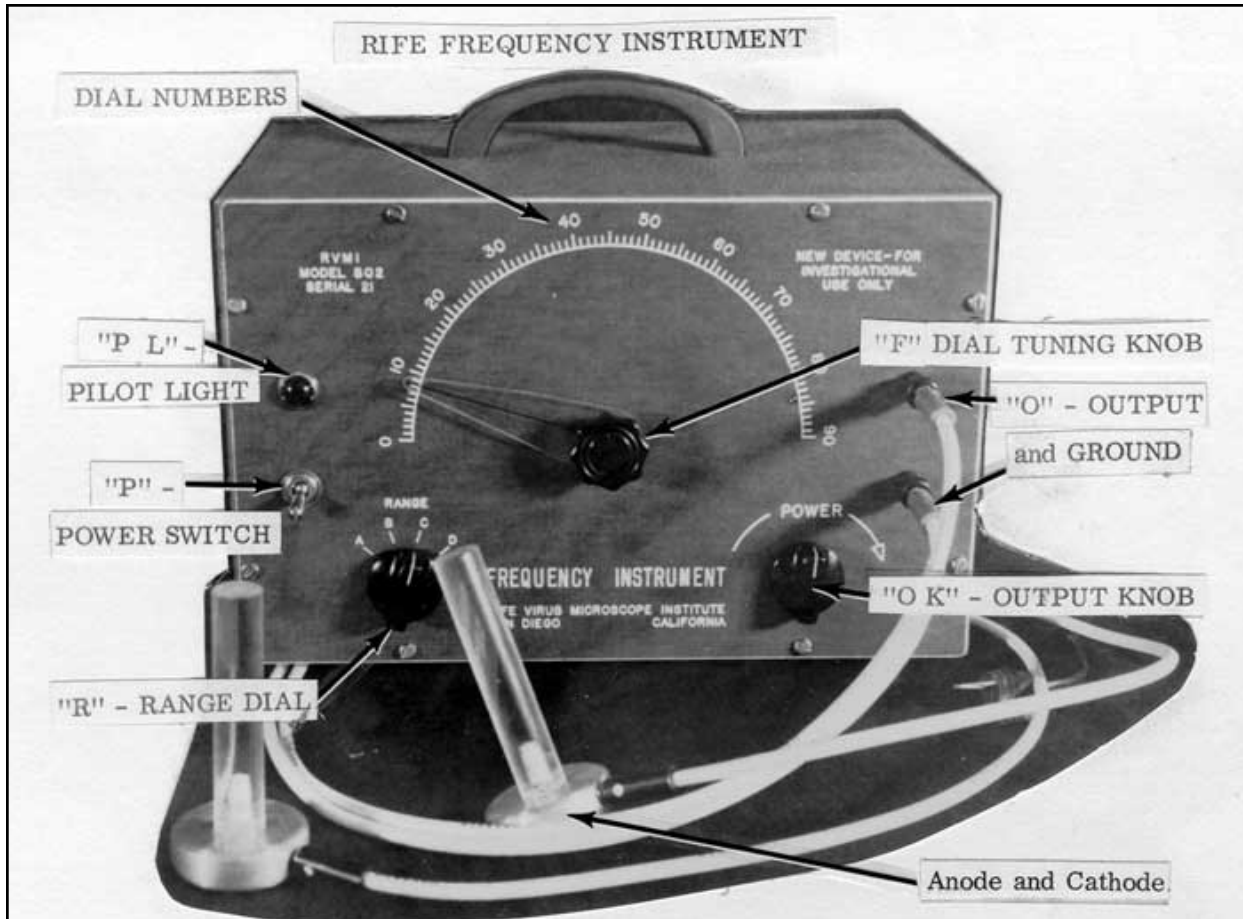

### AUDIO SQUARE WAVE GENERATOR

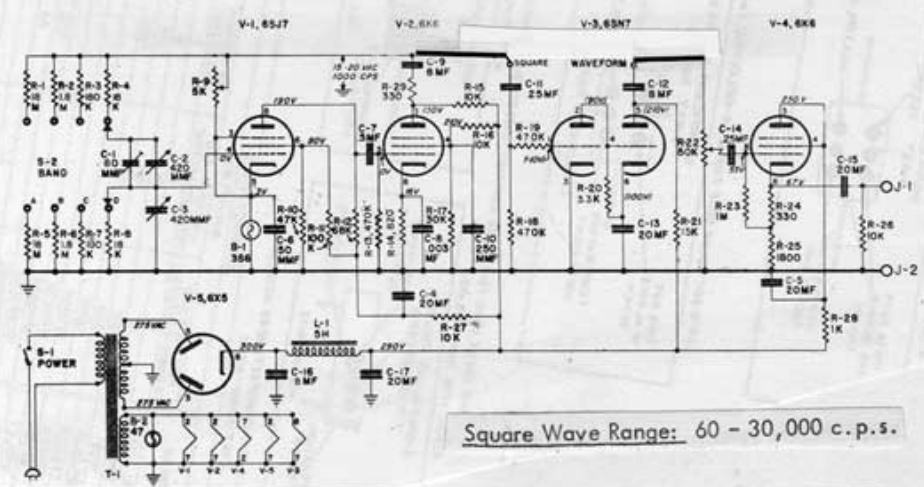

Square Wave Range: 60 - 30,000 c.p.s.

Rated Output Power: 100 milliwatts into rated load (10 volts across a 1000 ohm resistive load).

## Summary

In summary, with all the historical information that has come to light in the past few years we finally know the truth about which frequencies were Dr. Rife's M.O.R.s and where the audio frequencies came from. These audio frequencies have accomplished a lot of good and have helped many people. With the use of even more audio frequencies a whole new field of frequencies are now available for our use. Having said this, we still need to remember Dr. Rife still maintained his true M.O.R. frequencies were in the RF band of frequencies. Even though Dr. Rife, John Crane and John Marsh tested these audio instruments in the 1950's and early 1960's to see how well they would work, it wasn't until after John Crane and John Marsh got out of prison that they received Dr. Stafford's report showing the failure of audio frequencies on cancer. From about 1964 on, John Crane and John Marsh continued to build the audio frequency instruments even though they had the evidence from Dr. Stafford which showed the audio frequencies alone didn't work on cancer like the original high RF frequencies. Just because John Crane and John Marsh said the audio frequencies were Dr. Rife's true M.O.R.s doesn't mean they were. It is difficult to understand why they chose not to believe the truth when it was right before their eyes. We would still be in the dark had it not been for the written documents that revealed Dr. Rife's high frequencies and the audio tapes which have Dr. Rife's own voice on them telling us his frequencies ranged from the audio to the broadcast bands. Dr. Rife was a pure scientist and only believed what he could prove. Had he seen Dr. Stafford's final report I am certain he would have considered the cancer tests a complete failure. Dr. Rife said "he never fooled himself". It is entirely possible that Dr. Rife would have insisted they go back to his or Philip Hoyland's original design and use a faraday cage.

Hopefully this information will help make a change and in the future we will begin to see what Dr. Rife's original high frequency M.O.R.s will do. Many helpful sources have provided the records and resources so this new information could be brought to light: the release of the John Marsh information from John Marsh's nurse to AAA Production Inc; the Beam Rays Trial Papers and photos from Jason Ringas of the Rife Research Group of Canada; the purchase and analyzing of the Verne Thompson instrument by Aubrey Scoon and the British Rife group; the help of James Cunningham along with the great detective work done by James Peters in figuring out that Dr. Rife was using the Kennedy company Model 110, 220 and 281 receivers. We also want to recognize the great work Jim Peters did on the schematic of Dr. Gruners original Beam Rays instrument. His recognition of the second variable Hartley Oscillator made it possible to rebuild the original Beam Rays instrument. The spectrum analyzing of these machines has finally given us the answers to how all these different instruments really worked. I believe the recognition of the Kennedy equipment and the 1930's Beam Rays schematic correction and rebuilding are two of the greatest pieces of information we have yet discovered about Dr. Rife. No longer are we guessing in the dark. We have purchased the Kennedy Company equipment Models 110, 220 and 281. We plan on doing more extensive spectrum analysis work on this equipment. We have built, into one case, the Beam Rays instrument design. We wish also to give special thanks to Henry Rogers the owner of the Western Historic Radio Museum ([www.radioblvd.com](http://www.radioblvd.com)). He allowed us the opportunity to come and test the Kennedy receivers that he owns. As more information comes out we will update this article as necessary.

For those who would like a complete list of Dr. Rife's frequencies output by the Kennedy equipment, Rife Ray #4, Philip Hoyland Beam Rays instrument and the audio frequencies of the 1940's and 1950's instrument we have listed them on the next page. The corrected frequencies that Philip Hoyland read off of the Kennedy equipment were all used in the Rife Ray #4 and Philip Hoyland's Beam Rays instrument design. Though both sets of the low audio frequencies are not true M.O.R.s they were used in the 1940's and 1950's and are included in this list. These audio frequencies have been used with very good results over the past 50 years by many people.

## Rife's High M.O.R. frequencies & less effective audio frequencies

Microorganisms From Rife's lab notes	Audio Freq. 1953 forward	Audio Freq. 1940-1953	Rife's MORs 1935 -1939	Rife's MORs from 1934 and before Misread Kennedy equipment frequencies		
	Verne Thompson 1950's Instru.	Verne Thompson 1940's Instru.	Rife Ray # 4 Hoyland	#1 Frequency	#2 Frequency	Meters converted to Hertz
	Hertz <i>Square Wave</i>	Hertz <i>Sine Wave</i>	Hertz <i>Sine Wave</i>	Hertz <i>Sine Wave</i>	Meters <i>Sine Wave</i>	<i>Sine Wave</i>
1. Actinomycosis (Streptothrix)	784	7,870	192,000	678,000	1,607	186,554
2. Anthrax			139,200	900,000	1,100	272,539
3. Anthrax Symptomatic				400,000	18,000	16,655
4. B. Coli (Rod form)	800	8,020	417,000	683,000	943	317,914
5. B. Coli (Filterable virus)	1,552	17,220	770,000	8,581,000	27	11,103,424
6. Bacillus X Filter passing (Cancer - carcinoma)	2,128	21,275	1,604,000	11,780,000	17.6	17,033,662
7. Bacillus Y (Cancer - carcinoma)	2,128	21,275	1,604,000	11,780,000	17.6	17,033,662
8. Cancer- Sarcoma (BX, BY ?)	2,008	20,080				
9. Bubonic Plague				160,000	585	512,466
10. Catarrh				1,800,000	175	1,713,100
11. Cholera Spirillum				851,000	312	960,873
12. Contagious Conjunctivitis				1,206,000	148	2,025,625
13. Diptheria				800,000	275	1,090,154
14. Glanders				986,000	407	736,591
15. Gonorrhea	712		233,000	600,000	1,990	150,649
16. Influenza				1,674,000	154	1,946,704
17. Leprosy	600	6,000		743,000	1,190	251,926
18. Pneumonia	776	7,660		1,200,000	785	381,901
19. Spinal Meningitis			427,000	927,800	167	1,795,164
20. Staphylococcus Pyogenes Aureus	728	7,270	478,000	998,740	540	555,171
21. Staphylococcus Pyogenes Albus					546	549,070
22. Streptococcus Pyogenes	880	8,450	720,000	1,214,000	142	2,111,214
23. Syphilis (Treponema Pallidum)	660	6,600	789,000	900,000	108	2,775,856
24. Tetanus	120	1,200	234,000	700,000	19,000	15,779
25. Tuberculosis (Rod form)	803	8,300	369,000	583,000	554	541,142
26. Tuberculosis (Virus form)	1,552	16,000				
27. Typhoid Fever (Rod form)	712	6,900	760,000	900,000	345	868,964
28. Typhoid Fever (Filter passing)	1,862	18,620	1,445,000	9,680,000	21.5	13,943,835
29. Worms		2,400				

Written by: Jeff Garff  
 AAA Production Inc.  
 Copyright © 2003 & 2008  
 www.rifevideos.com