

# MICRO



# SOLUTIONS

A MICROCHIP TECHNOLOGY INC. PUBLICATION

MAY/JUN 2016

# MASTERS 2016

Since **20** YEARS 1997

*Inspire. Inform. Innovate.*

**6** Lock Down  
Your Design

**11** Connected  
Thermometer

**22** From Zero  
to the IoT

# MICRO SOLUTIONS

A MICROCHIP TECHNOLOGY INC. PUBLICATION

contents

## COVER STORY

### 4 Inform. Inspire. Innovate.

Celebrating 20 Years of Providing In-Depth Technical Training to Embedded Control Engineers

## NEW PRODUCTS

### 6 Lock Down Your Design

Securing Internet of Things Applications with CEC1302 Hardware Cryptography-Enabled 32-bit Microcontroller

### 8 Ready for More?

Microchip's Voltage Reference Portfolio Expands to Provide Additional Options for Your Latest Designs

## NEW TOOLS

### 10 Building Blocks for LPWANs

Microchip Debuts Industry's First LoRa® Technology Evaluation Kits for Developing Low-Power Wide-Area Networks in Europe and North America

### 11 Connected Thermometer

Reference Design Aids in Development of Low-Cost Digital Thermometer for Handheld Use or Integration into Wearable Device

### 12 Artistic Appeal

Easily Develop and Design Professional-Looking Graphical User Interfaces for Applications Using PIC32 Microcontrollers

## DEV TOOL DEALS

### 13 Warm Up to These Savings

## DESIGN CORNER

### 15 The Future of Machine Vision

### 19 Use Simple Logic

### 20 Simply, Quickly, Widely

### 22 From Zero to the IoT

### 24 Designing for the Hyperloop

## VISIT MICROCHIP AT



**sensors**  
expo & conference

June 22-23

BOOTH #716

McEnergy Convention Center - San Jose, CA

The Microchip name and logo, the Microchip logo, dsPIC, FlashFlex, KEELOQ, KEELOQ logo, MOST, MPLAB, mTouch, PIC, PICmicro, PICSTART, PIC32 logo, Quiet-WIRE, rPIC, SST, SST Logo, SuperFlash and UNI/O are registered trademarks of Microchip Technology Incorporated in the U.S.A. and other countries. FilterLab, Hampshire, HI-TECH C, Linear Active Thermistor, MTP, SEEVAL and The Embedded Control Solutions Company are registered trademarks of Microchip Technology Incorporated in the U.S.A. Silicon Storage Technology is a registered trademark of Microchip Technology Inc. in other countries.

Analog-for-the-Digital Age, Application Maestro, BodyCom, chipKIT, chipKIT logo, CodeGuard, dsPICDEM, dsPICDEM.net, dsPICworks, dsSPEAK, ECAN, ECONOMONITOR, FanSense, HI-TIDE, In Circuit Serial Programming, ICSP, MIndi, MiWi, MPASM, MPF, MPLAB Certified logo, MPLIB, MPLINK, Omniclient Code Generation, PICC, PICC-18, PICDEM, PICDEM.net, PICkit, PICtail, REAL ICE, rLAB, Select Mode, SQL, Serial Quad I/O, Total Endurance, TSHARC, UniWinDriver, WiperLock, ZENA and Z-Scale are trademarks of Microchip Technology Incorporated in the U.S.A. and other countries.

SQTP is a service mark of Microchip Technology Incorporated in the U.S.A. GestIC and ULPP are registered trademarks of Microchip Technology Germany II GmbH & Co. & KG, a subsidiary of Microchip Technology Inc., in other countries. The LoRa name and associated logo are registered trademarks of Semtech Corporation or its subsidiaries. All other trademarks mentioned herein are property of their respective companies. © 2016, Microchip Technology Incorporated, All Rights Reserved.



## Two Million Tools Shipped

**O**n May 17, 2016, Microchip announced that we had shipped our two millionth development tool. Over the years, our portfolio of development tools has continued to grow and expand, including the free and award-winning MPLAB® X Integrated Development Environment (IDE), free and optimizing MPLAB XC Compilers and the popular low-cost PICKit™ 3 and MPLAB ICD 3 In-Circuit Debuggers. Our vast selection of development tools can support nearly any embedded design application using our microcontroller, digital signal controller or analog components.

“We are incredibly proud and excited to celebrate this tremendous accomplishment,” said Derek Carlson, vice president of development tools at Microchip. “Microchip is committed to offering our customers a diverse and quality set of development tools. With over 1,600 development tools, we truly feel we have something to offer every embedded engineer for virtually every application.”

In celebration of this amazing milestone, we are offering 20% off all core development tools until the end of June. This **“Two Million Tools Shipped”** promotion includes some of our most popular development tools, including the PICKit 3 In-Circuit Debugger, MPLAB ICD 3 In-Circuit Debugger, and MPLAB REAL ICE™ In-Circuit Emulator, as well as all MPLAB XC PRO Compiler workstation licenses and the MPLAB REAL ICE Power Monitor board. This is a great opportunity for you to get some excellent resources for developing your next embedded design at special prices.

Thank you to all our customers who have entrusted us with their designs. We plan to continue to deliver new and advanced solutions to help reduce your development costs and time to market, while also giving you a competitive edge to deliver innovative new products. In fact, in this issue of MicroSolutions, you will read about the industry’s first complete LoRa® technology evaluation kits. These kits deliver all the resources many customers have been requesting to help them get started with developing their Internet of Things and other connected applications using this exciting new wireless technology.

As always, we would be happy to get your feedback on MicroSolutions. Feel free to email us at [MSFeedback@microchip.com](mailto:MSFeedback@microchip.com).

---

Microchip Technology Inc.  
2355 W. Chandler Blvd. | Chandler, AZ 85224 | [www.microchip.com](http://www.microchip.com)

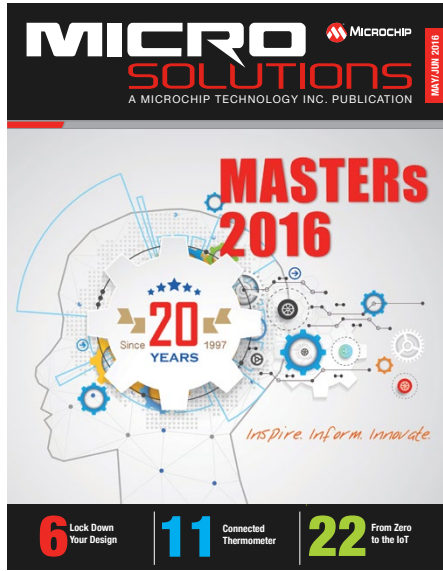

### Don't Miss the Next Issue of MicroSolutions

Published six times a year, MicroSolutions is a valuable resource for product and technology news about Microchip’s innovative solutions. Subscribe today to receive email notifications when each new issue of MicroSolutions is ready. Use the link below:



### Find Us on These Social Channels





# INSPIRE. INFORM. INNOVATE.

**Celebrating 20 Years of Providing  
In-Depth Technical Training to  
Embedded Control Engineers**

**Registration Now Open for Microchip's 2016  
MASTERS Conference**

**T**wenty years ago, a group of visionaries at Microchip came to the conclusion that we needed to offer our customers top-notch technical training on our products and general embedded control topics to help them successfully develop innovative products for their rapidly evolving markets. Sometimes application notes and data sheets were simply not enough to guide engineers through their complex design issues. At that time, there was no such thing as "online training"; in fact, most of us were still using 33K modems to access the Internet. So an idea was hatched to bring customers and Microchip engineers together in a single place, lock them in some rooms with computers and demo boards for a few days and see what happened. That first gathering was held in Phoenix and offered about 35 classes to about 150 attendees. The MASTERS Conference was born.

*(continued on page 5)*

Now fast forward to 2016. Due to its ongoing success over the years, MASTERS has expanded to be held in nine locations across seven countries around the globe. This technical training event equips system design engineers at every level of experience with extensive product information and hands-on training on our latest technologies, products and development tools. Classes cover a wide range of topics and are taught by Microchip's application and design engineers. In addition to interacting with Microchip's team of experts, MASTERS attendees can network with their peers and meet representatives from some of Microchip's third-party partners.



The 2016 MASTERS Conference, scheduled for August 17-20 in Phoenix, is going to be a very special celebration. We are expecting more than 700 attendees from around the world to join us. Our program offers more than 110 classes on a wide range of embedded control topics. In addition to our core classes on our latest products, debugging and development tools, we are offering a number of new classes on topics that include Bluetooth®, crypto processors, biometric sensing, motor control and an entire group of sessions on the Internet of Things (IoT). The **2016 Event Guide** provides a full listing of the classes being offered. These classes provide you with an outstanding opportunity to learn from our expert engineers who will equip you with the knowledge and skills you need to get up and running quickly with your own applications after the conference is over.



Steve Sanghi, Microchip's CEO, will kick off this year's event with an opening night keynote session on Wednesday, August 17th. The following evening, Grant Imahara, a celebrity electrical engineer known for his work on the hit TV show *MythBusters*, and now Mouser Electronics Spokesperson, will be our guest speaker. He will then open the floor for a live Q&A session where you will have the opportunity to meet him personally and take photos. This year's program also features a variety of evening classes and activities including an Inventors Showcase, friendly competitions like Hover Curling and Battle Block Racers, a trip to Fry's Electronics, Casino Night and more. MASTERS will be held at the beautiful JW Marriott Desert Ridge Resort, Arizona's largest luxury resort, offering a range of amenities and activities.



While the regular conference offers you many opportunities to learn, for those who would like to attend as many classes as possible and maximize the experience, we also offer a two-day Pre-Conference program on August 15-16 for an additional fee.

Registration for MASTERS 2016 in Phoenix is open now. If you would like to be inspired and informed about the latest products and technologies that can help you innovate with your designs then visit the **MASTERS website** to get all the details. We hope to see you there. 



# Lock Down Your Design

Securing Internet of Things Applications with CEC1302 Hardware Cryptography-Enabled 32-bit Microcontroller

Offers Significant Performance Improvement Over Firmware-Based Security Solutions

In the fast-paced world of electronics, the need for not only smart but connected devices is rapidly growing, especially for use in Internet of Things (IoT) applications. While connectivity brings the advantages of control, sensing and the ability to update system software over the Internet, it also opens the door to security breaches. These security threats are increasing exponentially in terms of frequency, targeted devices, malignancy and costs of attacks.

Firmware-based security solutions are available, but the inclusion of cryptography in hardware is a game changer for designers of today's connected devices. Hardware-based cryptography offers a level of speed and security for the latest low-power devices that just isn't possible when implemented in firmware.

Microchip's **CEC1302** is a new hardware crypto-enabled 32-bit microcontroller with an ARM® Cortex®-M4 core that makes it



easy to add security to IoT and other connected devices. Its sophisticated security capabilities deliver the benefits of being connected to the Internet without the typical security concerns. Also, the CEC1302's hardware-based cryptography suite offers significant performance improvements over firmware-based solutions. The hardware-enabled public key engine of the device is 20 to 50 times faster than firmware-enabled algorithms, and the hardware-enabled hashing is 100 times faster.

The CEC1302 allows for pre-boot authentication of the system firmware in order to ensure that the firmware is untouched and uncorrupted, thereby preventing security attacks such as man-in-the-middle, denial-of-service and backdoor vulnerabilities. It can also be used to authenticate any firmware updates, protecting the system from malware or memory corruption.

The CEC1302 provides private key and customer programming flexibility.

Offered as a full-featured microcontroller in a single-package solution to minimize customer risk, the CEC1302 provides private key and customer programming flexibility. The device delivers savings in terms of power drain and also improved execution of application performance. Adding security functionality only results in a small additional cost. The CEC1302 can be used as a standalone security coprocessor or can replace an existing microcontroller in your design.



Get all the benefits of connecting your application to the Internet without the typical security concerns.

(continued on page 7)

# Development Support

You can quickly develop applications based on the CEC1302 with MikroElektronika's **CEC1302 Clicker** (MIKROE-1970) and **CEC1302 Clicker 2** (MIKROE-1969). These boards can be used with MikroElektronika's complete development toolchain for Microchip CEC1302 ARM Cortex-M4 MCUs, which includes compilers, development boards and programmers/debuggers, or with standard third-party ARM MCU toolchains.

## NEW PRODUCTS

The CEC1302 comes in a 144-pin WFBGA package and is available now for sampling and volume production. You can order it from **microchipDIRECT** or from **Microchip's worldwide distribution network**. 



Microchip's Custom Reel Service Now Available  
**ORDER ANY QUANTITY UP TO A FULL REEL**

**microchip**  
**DIRECT**

## Industry's Most Complete Configurable MEMS Timing Solutions

- Two weeks production time
- 5× better vibration tolerance, 500× better mechanical shock tolerance
- High stability, low power, ultra-small packages



# Ready for More?

Microchip's Voltage Reference Portfolio Expands to Provide Additional Options for Your Latest Designs

Select from High-Accuracy Family and Low-Cost, Industry-Standard Family

Voltage references are important components in most digital logic, mixed-signal and analog circuits. Until recently, Microchip has only offered two voltage reference options: the 2.5V **MCP1525** and the 4.096V **MCP1541**. However, within the past year we have more than tripled our portfolio of voltage references with the additions of the highly accurate, low-noise **MCP1501** series-type voltage reference family and the cost-effective and industry-standard **LM4040** and **LM4041** shunt-type voltage reference families. These devices are well suited for a range of applications including battery-powered devices, data acquisition systems, instrumentation, medical equipment, automotive electronics and more.

## High Accuracy for Precise Performance

If you are developing a high-performance design, the MCP1501 offers eight voltage variants from 1.024V to 4.096V, with a very

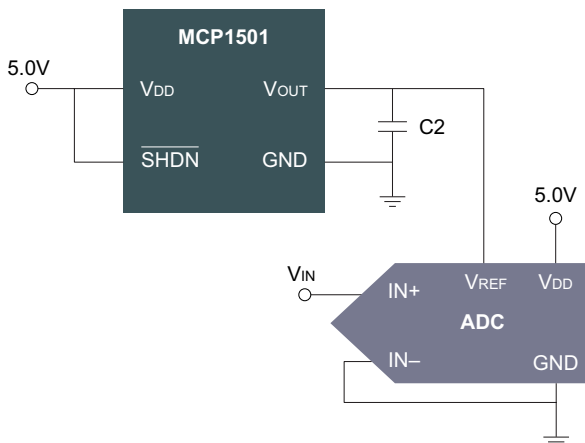

Figure 1 - MCP1501 Simplified Block Diagram



high initial accuracy of just  $\pm 0.1\%$  and a temperature coefficient of 50 ppm/ $^{\circ}\text{C}$ . Voltage references are commonly used to improve the performance of an ADC, as illustrated in Figure 1. The ADC's performance is affected by the voltage reference as the ADC code is inversely proportional to the voltage reference, which is shown in Equation 1. Therefore, using a voltage reference with tight initial error can help eliminate room-temperature system calibration.

$$\text{Code} = V_{IN} \times \frac{2^n}{V_{REF}}$$

Equation 1

Also, the low output noise of less than 0.1  $\mu\text{VP-P}$  from 0.1 Hz to 10 Hz helps maintain converter accuracy for high-resolution ADCs. As illustrated in Equation 2, the voltage reference output noise must be smaller than the Least Significant Bit (LSB) voltage. For example, the LSB for a 24-bit ADC with a 4.096V voltage reference is just 0.244  $\mu\text{V}$ .

$$\text{LSB} = \frac{V_{REF}}{2^n}$$

Equation 2

The MCP1501 family is available in a very small  $2 \times 2$  mm WDFN, which is ideal for sensor applications, as well as in SOT-23 and SOIC packages.

## Space and Cost Savings in Industry-Standard Package

For applications where space and cost savings are significant factors, the LM4040 and LM4041 come in a simple 3-lead

(continued on page 9)



SOT-23 package with an industry standard pinout. The LM4040 is available with fixed reverse breakdown voltages of 2.5V, 4.096V and 5.0V. The LM4041 is available with a fixed 1.225V or an adjustable reverse breakdown voltage. Versions include initial accuracies and temperature coefficients of  $\pm 0.5\%$  and 100 ppm/ $^{\circ}\text{C}$  or  $\pm 1\%$  and 150 ppm/ $^{\circ}\text{C}$ .

The MCP1501, LM4040, and LM4041 are available now for sampling and volume production and can be purchased from [microchipDIRECT](#) or from [Microchip's worldwide distribution network.](#) 

# Do You Love A SALE ?

Visit the [microchipDIRECT Discount Page](#) for a unique opportunity to purchase a number of in-stock Microchip products at a considerable discount. These prices are only available while supplies last, so check out the list of discount devices today.



## Simplify Your Bluetooth<sup>®</sup> IoT Prototype

Skip the Learning Curve with Microchip's Bluetooth Low Energy Client Module



# Building Blocks for LPWANs

Microchip Debuts Industry's First LoRa® Technology Evaluation Kits for Developing Low-Power Wide-Area Networks in Europe and North America

Each Turnkey Kit Includes LoRaWAN™ Gateway, Two Sensors and a Local Server Application

Driven by the LoRa Alliance, LoRa wireless technology is able to achieve a range of up to 10 km and 10-year battery life. This exciting technology, which is already being implemented in numerous projects, targets low data rates and low-duty-cycle applications for tracking and monitoring such things as energy, location, utility infrastructure, smart city, environment, agriculture and public safety. Although predominantly used for the uplink of sensor data, bidirectional communications allow real-time acknowledgement of mission-critical data and downlink control of remote actuator nodes.

Ever since we announced the industry's first certified LoRa module earlier this year, many of our customers have been asking for resources to help them get started with developing their projects. As another industry first, we now offer complete LoRa technology evaluation kits that provide all the components you need to create a Low-Power Wide-Area Network



LoRa® wireless technology is able to achieve a range of up to 10 miles and 10-year battery life.



(LPWAN) in Europe (868 MHz band) or North America (915 MHz band). Each kit includes two Motes (LoRaWAN™ sensors) based on our **RN2483** or **RN2903** LoRa modules, a LoRaWAN gateway and a local LoRaWAN server application that is accessible via an Ethernet interface. Each kit also includes an Ethernet cable, three USB cables and three antennas.

Develop a long-range  
LoRa network right  
at your desk.

These kits serve as building blocks for developing a long-range LoRa network right at your desk. Designed to make it easy for you to test LoRa technology's range and data rate, they will also enable you to experience up to 10 miles of range and 10 years of battery life using two AAA batteries. LoRa technology utilizes spread spectrum modulation which delivers excellent data robustness in a noisy environment and works through physical obstructions. Because the two Motes are European R&TTE Directive Assessed or FCC Certified, your time to market can be significantly reduced through the simplification of standards and government regulatory certification.

The **DV164140-1** for Europe and **DV164140-2** for North America can be purchased from microchipDIRECT for \$499.99 each. For additional information, contact your nearest **Microchip sales office.** 



# Connected Thermometer

Reference Design Aids in Development of Low-Cost Digital Thermometer for Handheld Use or Integration into Wearable Device

Features Cost-Effective 8-bit MCU, Integrated Capacitive Touch and Bluetooth® Module

Digital thermometers have been used for some time in traditional medical settings, but digital temperature measurement devices are starting to be found in many new and exciting places. For example, the ability to measure temperature is now being integrated into many consumer products such as connected fitness and medical activity trackers. These new applications require a variety of features to make them dependable and cost effective in a competitive market. The Connected Thermometer Demonstration Board shows how easy it is to implement a Bluetooth-connected digital thermometer using our 8-bit **PIC16F1519** microcontroller (MCU) and **RN42** Bluetooth Module.

The PIC16F1519 is a cost-effective eXtreme Low Power (XLP) 8-bit microcontroller with an integrated mTouch® capacitive touch sensing module. It also features a 28-channel 10-bit Analog-to-Digital Converter (ADC) and a fixed voltage reference

with selectable voltage level outputs. It is available in several package types, including a small Ultra-Thin QFN (UQFN) package for space-constrained designs.

Our small-form-factor RN42 Bluetooth 2.1 + EDR Module is used to provide connectivity to this board, however, this design can also be easily implemented using any of our Bluetooth Low Energy or Wi-Fi® connectivity modules. Because it is Bluetooth SIG qualified and fully certified, the RN42 Bluetooth Module offers rapid time to market for connected designs. It features an on-board embedded Bluetooth stack, so no host processor is required, and it supports the Bluetooth data link to iPhone®, iPad® and iPod® Touch devices. It also offers 128-bit encryption for secure communications, programmable low-power modes and local UART and over-the-air RF configuration.

This reference design features a low overall BOM cost due to function integration. Temperature is measured in Fahrenheit or Celsius and is shown on the OLED display. The buttons are implemented using mTouch integrated capacitive touch technology. Taking advantage of the PIC® MCU's battery-friendly features, the board is powered by two AAAA batteries.

If you would like to develop a low-cost digital thermometer for your handheld or wearable application, visit the [Connected Thermometer Demonstration Board page](#) on our website to learn more. Go to the Resources section to download the free schematics and 'C' source code that can easily be modified to your specific application needs. Contact your local [Microchip sales representative](#) to see a working demonstration of the Connected Thermometer Demonstration Board. 

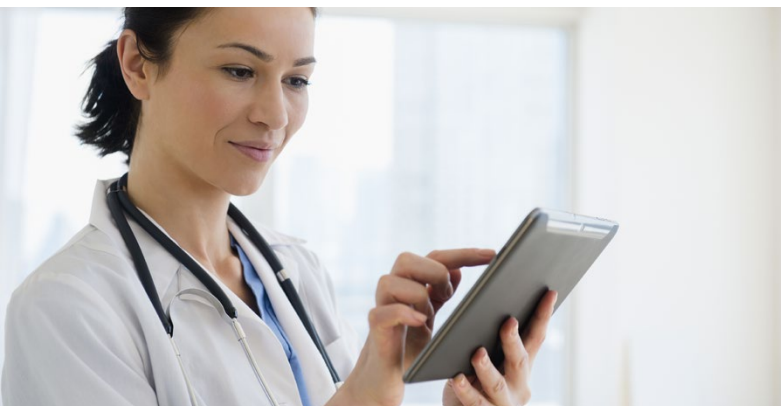
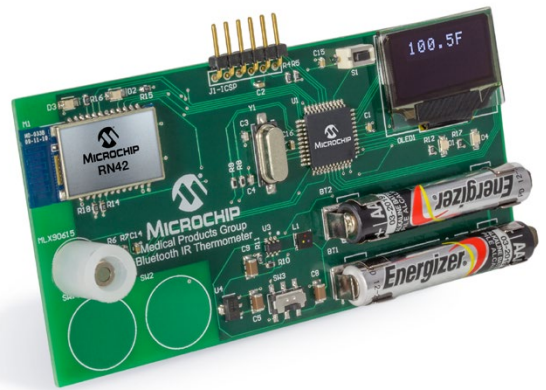

*Adding connectivity to digital thermometer applications enables remote monitoring of patients.*



# Artistic Appeal

NEW TOOLS

Easily Develop and Design Professional-Looking Graphical User Interfaces for Applications Using PIC32 Microcontrollers

Free Graphical User Interface Composer Tool for MPLAB® Harmony Now Available

Product differentiation is essential in today's competitive marketplace. Offering customers aesthetically pleasing content on a product's Graphical User Interface (GUI) is a key element in driving brand recognition and preference. However, this can be challenging for product developers who typically are not graphic artists and lack the necessary design resources.

MPLAB Harmony Graphics Composer (MHGC) is a modern and flexible graphical user interface (GUI) composer tool that can be used in designs that use PIC32 microcontrollers. This free development tool is available through Microchip's Harmony Configurator and MPLAB X Integrated Development Environment (IDE). The software allows anyone to create visually appealing branded content using the Harmony Graphics Library, in conjunction with their custom assets, to develop

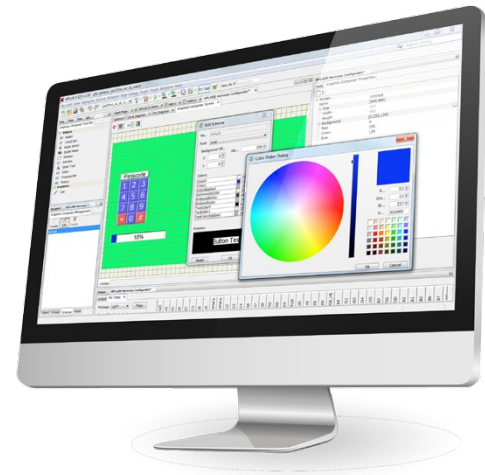

GUIs in a What-You-See-is-What-You-Get (WYSIWYG) design model, without requiring complex and cumbersome coding.

Now you can develop professional-looking GUIs without needing any special training or design skills. MPLAB Harmony Graphics Composer takes care of all configuration requirements and generates all the necessary source code. MHGC's intuitive, user-friendly interface lets you easily import images and fonts and add them into your project. The tool also allows you to add, delete, move, scale and configure objects within the application. These objects can be interactive—including sliders, dials and buttons—without any need for you to understand the underlying graphics code.

Watch this video to learn more about the simple and intuitive MPLAB Harmony Graphics Composer:



It's easy to get started with adding artistic appeal to your design. Simply download MPLAB Harmony Graphics Composer for free from the [MPLAB Harmony web page](#). You will find additional resources there as well to assist you with developing your PIC32 MCU-based project. 



Create compelling graphics to drive brand recognition and preference for your product.

# Warm Up to These Savings

June is a great month to save on some of our special tools for adding wireless capability to your design, developing motor applications, or experimenting with one of our 8-bit PIC® microcontrollers. To take advantage of our special sale prices, click on the links below, add the item to your cart on microchipDIRECT and include the coupon code during check-out. These are limited-time offers, so act quickly to get your savings while the deals are still available and supplies last.

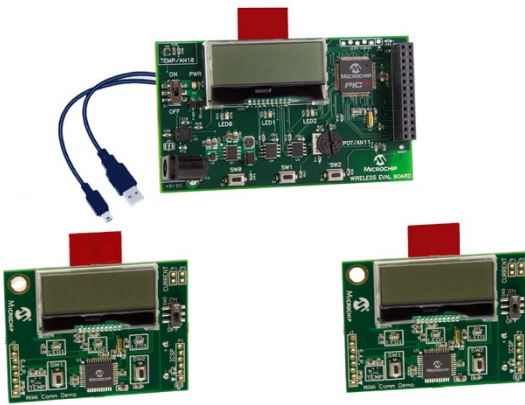

## MiWi™ Protocol to Wi-Fi® Wireless Demo Kit (DM182018)

microchipDIRECT Coupon Code: TP1622

Evaluate and experiment with the MiWi wireless networking protocol and Wi-Fi gateway solutions. The **MiWi Protocol to Wi-Fi Wireless Demo Kit** includes all you need to create a three-node MiWi protocol network. The price has been reduced by almost \$70 during the month of June, so order yours today.

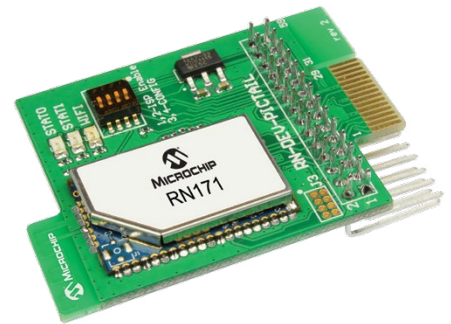

## RN-171 PICTail™/PICTail Plus Daughter Board (RN-171-PICTAIL)

microchipDIRECT Coupon Code: TP1624

The **RN-171-PICTail™/PICTail Plus Daughter Board** makes it easy to develop Wi-Fi applications using our 8, 16 and 32-bit PIC® MCUs. It includes a fully integrated TCP/IP stack allowing for a simple serial to Wi-Fi connection to the microcontroller. Save \$10 off the regular price.



## RN171 Evaluation Kit (RN-171-EK)

microchipDIRECT Coupon Code: TP1623

Quickly add Wi-Fi connectivity to your embedded application with the **RN-171-EK Evaluation Kit**. It can be powered by a USB cable (included in the kit) or by batteries, and it can be connected directly to a PC via the USB interface or to embedded processors through the TTL/UART interface. It also includes two convenient pushbuttons for controlling both SoftAP and WPS (Wi-Fi Protected Setup) mode without software configuration. Get \$20 off the regular price.

(continued on page 14)

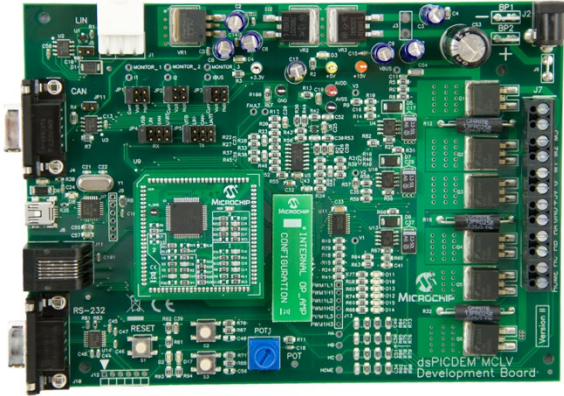

## dsPICDEM™ MCLV-2 Development Board (DM330021-2)

microchipDIRECT Coupon Code: TP1625

Are you looking for a cost-effective resource for developing sensed or sensorless Brushless DC (BLDC) and Permanent Magnet Synchronous Motor (PMSM) control applications? The **dsPICDEM MCLV-2 Development Board** works with all our 16-bit dsPIC Digital Signal Controllers and is capable of controlling motors rated up to 48V and 15 Amps. It's on sale now for \$30 off the regular price.

## PICkit™ 44-Pin Demo Board (DM164130-4)

microchipDIRECT Coupon Code: TP1626

The **PICkit™ 44-Pin Demo Board** includes an 8-bit PIC18F45K20 microcontroller, a small surface-mount prototype area and a 6-pin ICSP header for using the board with a PICkit 3 In-Circuit Debugger. The kit also includes two bare PCB boards you can use to customize your development. Save almost 30% off the regular price.

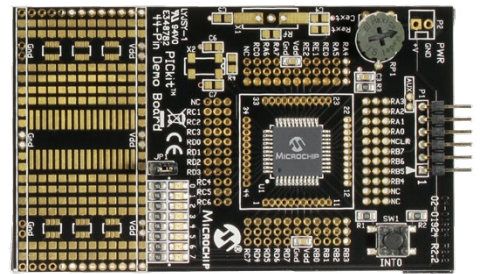

# Amazing!

**2 Million Tools Shipped and Counting**  
**Celebrate with 20% Off Our Core Tools**

(Click here for all the details)







# The Future of Machine Vision

## Tackling the Demands of High-Speed Digital Imaging with CoaXPress® Technology

In the digital imaging world, standards such as Camera Link®, FireWire® and USB 2.0 have admirably served their intended purpose, but machine vision has changed dramatically since they were developed. While they all remain serviceable for some systems, they have reached the end of the road for the most demanding applications. Consequently, GigE Vision®, USB3 Vision™ and CoaXPress, are competing to take their place. Each one has its strengths and weaknesses but it is CoaXPress that will be the “likely winner”, as it has the ability to meet today’s most stringent requirements—all at lower cost per bit and with greater flexibility than the alternatives.

To defend this admittedly bold statement, it helps to start with a discussion of how the potential successors to Camera Link, USB 2.0 and FireWire are utilized and the unique demands

placed on any potential vision system. A good place to start is the ever-increasing need for faster and higher manufacturing throughput in factories. The vision inspection system has previously been the limitation on factory output. In order to achieve higher throughput, vision systems must capture very-high-resolution (uncompressed) images much faster while processing at a much greater speed.

In addition, image processing systems must be able to process a moving or still image and make a go/no-go decision within milliseconds of image capture. Advancements in Complementary Metal-Oxide Semiconductor (CMOS) image sensors are occurring rapidly and these devices are now capable of much higher sensitivity and speed, dynamic range, and resolution. Image sensors which support 4K resolution are becoming common. In fact, at least one manufacturer is producing sensors with a resolution up to 250 megapixels. Consequently, the communications bus linking the camera to its processing resources must have significantly greater bandwidth and throughput, so Camera Link, USB 2.0 and FireWire simply won’t be fast enough.

These requirements aren’t limited to only traditional machine vision applications such as manufacturing and production either. For example, traffic and license plate monitoring and autonomous vehicles will require cameras that can produce extraordinary detail and color accuracy. Additional uses are medical imaging and telesurgery systems, which demand precise imaging with virtually no latency. Other challenging applications include video surveillance, aircraft infotainment,

*(continued on page 16)*



and high-speed board-to-board communications, as well as defense and aerospace systems.

All of these applications will push the boundaries further than ever before. To meet their requirements, higher bandwidths throughout the signal path up to 1200 megabytes per second (MByte/s) will initially be needed with gradually increasing data rates in the future. Systems that require longer cable runs must be able handle these higher speeds with the least expensive cable and connector solutions as well.

The number of manufacturers of camera and frame-grabber equipment adopting CoaXPress continues to grow, as it offers them the easiest way to transition to high-speed digital imaging while minimizing deployment costs with speeds four times faster and ranges 10 times longer than competing solutions.

To be truly effective, a communications bus must combine simplicity (ideally plug-and-play), the capability for customization, the lowest possible cost per bit, as well as the ability to scale in performance with little or no additional hardware. Bearing all of this in mind, examining each candidate standard demonstrates its viability in these environments.

Name	Data Rate (MByte/s)	Number of Cables Required	Maximum Distance	Cable Type
<b>Camera® Link</b>				
Base	255	1	10m	Proprietary
Medium	510	2	10m	Proprietary
Full	680	2	5m	Proprietary
80 Bit	850	2	4m	Proprietary
<b>GigE Vision®</b>				
Gigabit Ethernet	115	1	100m	Off the Shelf Cat 5/6
<b>USB3 Vision®</b>				
USB 3.0	400	1	3m	Off the Shelf USB
<b>CoaXPress®</b>				
CXP-1	120	1	140m	Off the Shelf Coax
CXP-2	240	1	110m	Off the Shelf Coax
CXP-3	300	1	100m	Off the Shelf Coax
CXP-5	480	1	60m	Off the Shelf Coax
CXP-6	600	1	40m	Off the Shelf Coax
2X CXP-6	1200	2	40m	Off the Shelf Coax
4X CXP-6	2400	4	40m	Off the Shelf Coax

Table 1 – Next-Generation Machine Vision Bus Standards Compared

## Camera Link

Camera Link is the mature standard; it is widely used, but requires bulky and expensive cables with limited cable lengths in the 4–10m range. Camera Link delivers data rates of 255 MByte/s (Base) to 850 MByte/s (80 bit), and some recent products support GenICam™. Connectors cannot be installed in the field, which is a major issue in some environments.

## GigE Vision

GigE Vision delivers data rates up to 115 MByte/s using Cat 5 or Cat 6 cable. As it rides on the back of the ubiquitous Ethernet—which is in millions of applications worldwide—it can be part of an existing network. It supports cable runs up to 100m and multi-camera applications, and it enables triggering.

As in all image capture applications, uncompressed image files represent the highest possible resolution but are far greater

in size than typical files. Because systems based on GigE Vision require that an image be compressed before sending it and later decompressed, this adds latency that is intolerable in some applications. GigE Vision is also capable of sending uncompressed data; however, since it is only 115 MByte/s in bandwidth, this presents a challenge.

## USB3 Vision

USB3 Vision uses the USB 3.0 standard and has the advantage of universal use in many applications. It does not require a frame grabber card and uses the GenICam programming interface. However, the lack of a frame grabber requires higher CPU usage. At 400 MByte/s, its highest data rate is not much greater than that of base Camera Link, so full support for some current and probably all next-generation sensors is unlikely. As with all USB variants, cable lengths are extremely short—about 3m.

(continued on page 17)



# CoaXPress

One of the newer machine vision standards in this mix, CoaXPress, has the



advantage of being designed from its inception to be a successor to Camera Link by addressing all of its shortcomings, which it has achieved. For example, it is the only one of these four options that allows video, camera control for triggering, and up to 13W of power to be delivered via a single, off-the-shelf 75Ω coaxial cable up to 100m with standard BNC or DIN1.0/2.3 connectors. It is an asymmetric, high-speed, point-to-point open serial communication standard that is royalty-free and supports GenICam, with a roadmap that extends to 1200 MByte/s over a single cable.

There is a misconception that CoaXPress can only be used in high-end applications. For lower end applications, CoaXPress sends uncompressed files, which results in near zero latency. That may not be necessary in systems where the bandwidth requirement is less than 115 MByte/s, cable distance is less than 150m and no power over cable is required. In this case CoaXPress may not be needed. Even though coax cable is inexpensive, its shielding makes it more resistant to EMI than other types of cable and enables automatic cable-loss equalization to increase achievable distance. In addition, BNC and DIN1.0/2.3 connectors are easily field-installable. The maximum data rate over a single cable is 600 MByte/s, and scalability is essentially infinite, limited only by the number of cables that can be accommodated. For example, the maximum range can still be maintained with a data rate to 2400 MByte/s when four cables are used. When simultaneously using additional cables for up to six lanes (see Table 2) a downlink speed of up to 3600 MByte/s is attainable over a distance of 40m with RG6 coaxial cable.

Configuration	Data Rate (MByte/s)	Maximum Range RG-6 (m)
CXP-1	120	140
CXP-2	240	110
CXP-3	300	100
CXP-5	480	60
CXP-6	600	40
4x CXP-6	2400	40
6x CXP-6	3600	40

Table 2 - CoaXPress® Configurations

The use of coax has other benefits as well. For example, it is still used in many older analog systems, making upgrades to higher-resolution digital cameras far easier and less expensive



than the alternatives. In addition, there are hundreds of different variants of 75Ω cable designed to accommodate abuse, extensive flexing, resistance to chemicals and other contaminants, and other environmental factors. These cables also don't suffer from skew that can be a factor with differential or multiple wires.

Although CoaXPress is designed to meet future imaging challenges, its scalability works both ways, making it usable in a vast number of applications other than those considered to be "high end". When the highest performance is not required, CoaXPress systems can be built using less expensive components. This is just one of the reasons why the standard is gaining popularity in a broad spectrum of applications and markets.

Three of the contenders to become the "gold standard" for next-generation machine vision—GigE Vision, USB3 Vision, and CoaXPress—have attributes that make them appealing in certain circumstances. However, for the majority of applications, CoaXPress has the broadest appeal. It was created from its inception to not only perform all of the functions that gave Camera Link its near-universal acceptance but also eliminates its weaknesses, while providing a cost-effective roadmap for satisfying tomorrow's machine vision demands. As a result, of the competing standards, 600 MByte/s CoaXPress offers the lowest cost, highest performance, and least power consumption.

## An Enthusiastic Response

Active Silicon and Adimec are two of the key companies driving the development of the standard that became CoaXPress, which was officially launched in November 2009. "We were well aware that Camera Link was running out of bandwidth, and knew of the considerable benefits of coax cable from the SDI broadcast standards," said Chris Beynon, Active Silicon's chief technology officer. "So a high-speed, coax-based imaging

(continued on page 18)



standard seemed a great solution for the industry. Now seven years later, that initial optimism has been proved justified, with CoaXPress being the dominant standard for very-high-speed imaging into computers.”

This opinion was seconded by Dr. Joost van Kuijk, CEO/CMO of Adimec. “We anticipated a need for industrial vision cameras with increased data rates based on the capabilities of CMOS image sensors and the way companies wanted to exploit them. This is why we adopted CoaXPress early on,” said van Kuijk. “We also took advantage of CoaXPress being a completely new interface standard to introduce features that would make integration and adoption simpler, such as using longer, flexible cables, that also handle power and control over a single cable.”

Manufacturers of frame grabbers have seen the benefits as they integrate CoaXPress into their product lines. “For our frame grabbers, the megabyte-per-second cost has dropped significantly,” said Donal Waide, director of sales at Bitflow. “On average, the cost is about one third of moving data on Camera Link, and we’ve seen an enthusiastic response from customers who compare costs between Camera Link and CoaXPress cameras that are sometimes twice and even four times faster.”

“The adoption of CoaXPress allows Matrox Imaging to offer leading-edge image capture boards with technological features and benefits previously unavailable with existing camera interface standards,” said Michael Chee, product manager at Matrox. “As a result, users have better tools to develop a high-performance, cost-effective imaging applications, and with additional advances from Microchip, Matrox Imaging will be able to deliver further innovative image capture solutions to the industry.”

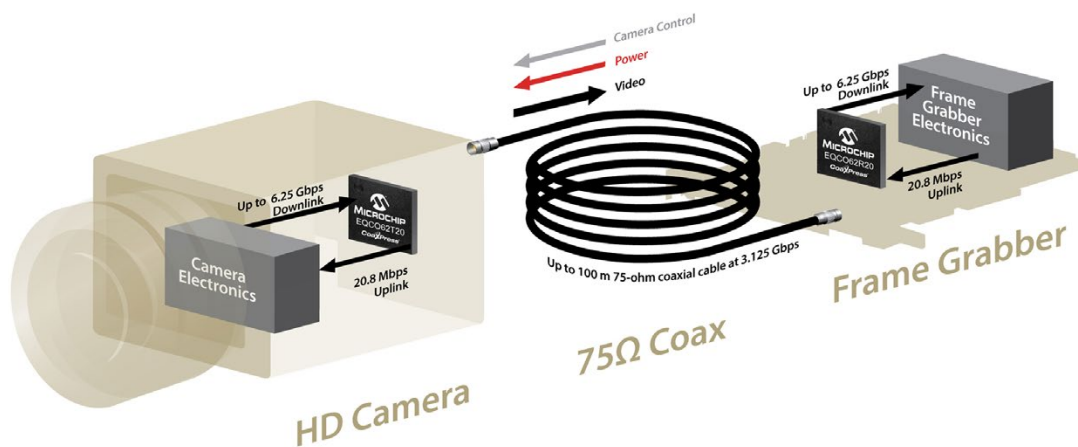

Figure 1 - Typical CoaXPress® Implementation

## Optimizing CoaXPress Performance

As noted earlier, equalization technology is a key determinant of the distance a CoaXPress cable can achieve while maintaining a given data rate. To optimize this parameter, Microchip’s 600 MByte/s CoaXPress chipset uses a proprietary auto-adaptive equalization algorithm that overcomes the degradation of digital signals from cable attenuation. The equalizer estimates the frequency-dependent losses introduced by the cable and compensates for them (see Figure 1).

The chipset includes two devices in QFN-packages: the **EQCO62T20** transmitter and the **EQCO62R20** receiver. These devices support cable runs up to 40m at 600 MByte/s with a very low power consumption of 140 mW from a single 1.2-VDC supply. A lower-speed, lower-cost version of the chipset is also available, comprised of the **EQCO31T20** and **EQCO31R20**, that can operate at up to 100m at 300 MByte/s. Both chipsets can be used as repeaters to achieve multiples of these distances. Camera control is managed through a full-duplex 20-Mbps uplink channel on the coax cable. The transmitter ICs are integrated in the camera and the receivers are integrated in the frame grabber or in the system head end to provide bi-directional signaling. Support for the current products includes a receiver (host) evaluation board and transmitter (camera) evaluation board.

Our CoaXPress product roadmap includes a second generation product. The CXP-12 will deliver data rates up to 1200 MByte/s downlink, simultaneous uplink speeds up to 42 Mbps, and power over a single coax cable.

Visit our [CoaXPress page](#) to learn more about this standard and to get more information about our latest products. 

CoaXPress is a J11A standard and the CoaXPress logo is used with permission from J11A.

# Use Simple Logic

## Discover How the Configurable Logic Cell Extends PIC® Microcontroller Capabilities

As one of the Core Independent Peripherals (CIPs) that are integrated into a number of PIC microcontrollers (MCUs), the Configurable Logic Cell (CLC) module enables the implementation of simple logic functions to achieve greater potential and flexibility in embedded designs.

The CLC can take up to 16 input signals and, through the use of configurable gates, performs the intended logic operation and provides an output that can be used to control other peripherals or I/O pin, as illustrated in Figure 1. The CLC module handles its tasks with no supervision from the CPU and implements programmable logic that operates outside the speed limitations of software execution. This peripheral supports a wide range of designs and simplifies the implementation of complex control systems.

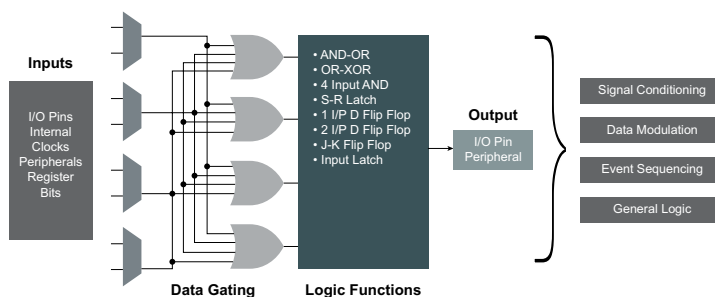



Figure 1 - Configurable Logic Cell Block Diagram

Here are some reasons why you should consider including the CLC in your next design:

- It can be used as a stand-alone peripheral in implementing sequential and combinational logic functions, thus facilitating quick event triggers and responses
- When used in conjunction with other peripherals, it helps extend the capabilities of those peripherals by facilitating custom complex functionality implementation in the hardware
- As a Core Independent Peripheral, it effectively reduces the CPU bandwidth requirement for an application, as many simple logic and event responses can be offloaded from the CPU to the peripheral
- Its use in many logic implementations reduces Flash and RAM requirements as software algorithms are not required
- It supports a higher level of integration without any external components and reduces PCB size

To learn more about how the versatile features and simplicity of the CLC can help extend the functionality of your PIC MCU-based design, download [Application Note 2133: Extending PIC MCU Capabilities Using CLC](#). Also, download our [16-bit PIC Microcontroller Peripheral Integration Quick Reference Guide](#) to discover other ways to boost your creativity and add functionality to your next design using our 16-bit PIC microcontrollers and dsPIC® digital signal controllers. 



# Simply, Quickly, Widely

## Connect Your Devices Within Wireless Mesh Networks

Contributed by MICRORISC Ltd.

Cooperation and communication are the biggest challenges currently facing the Internet of Things (IoT). As smart systems and devices continue to proliferate, they require many more complex networks to be implemented to deliver seamless connectivity. These networks are used in smart cities, intelligent buildings and a wide range of remote applications. To support this growing demand, the **IQRF® Alliance** has developed a formula for enabling various products to communicate via wireless mesh networks, simply.

The low-power, low-speed and low-data-volume **IQRF wireless technology** was invented by **MICRORISC**, a Czech company focused on research, development and delivery of technologies and components to electronics manufacturers worldwide. This

robust and reliable connectivity solution uses data-controlled transceivers to communicate with devices using simple commands. Featuring simplicity of use, IQRF wireless connectivity can be incorporated into almost any electronic device or system within just a few weeks. IQRF technology also uses the IQMESH protocol to enable sophisticated routing in harsh environments. This means that a message can be delivered even if a network is impeded by many obstacles. If there is any possible way to route a message, IQRF technology will deliver it, quickly.

A growing number of interoperable wireless devices and new systems are being added into the IQRF ecosystem under the umbrella of the IQRF Alliance. This organization currently consists of over 50 technical companies and universities in

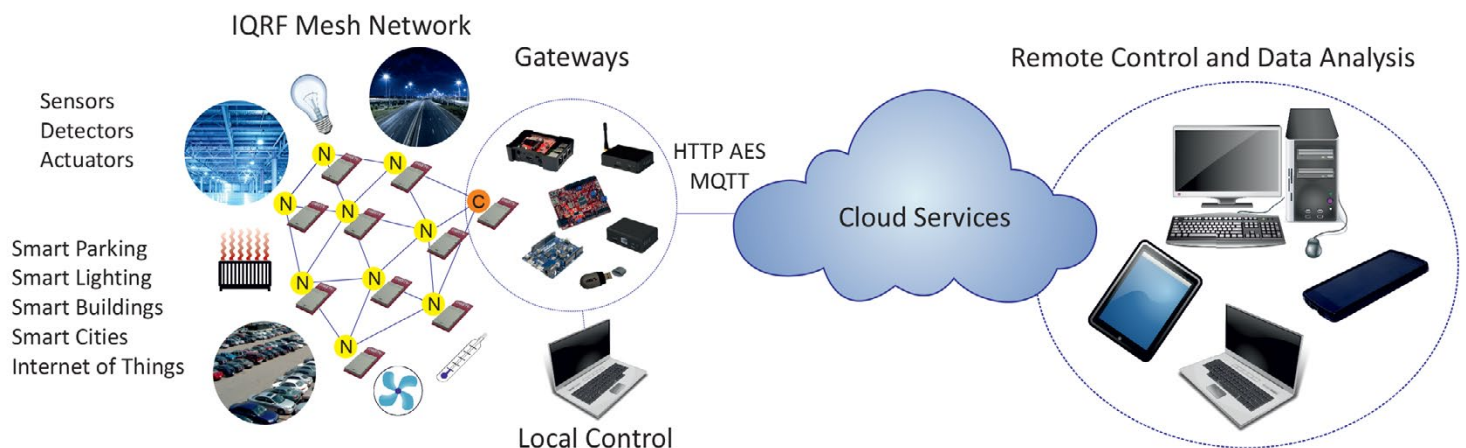

(continued on page 21)



the US, Great Britain, Scandinavia, Central Europe, Israel and India, all of which are using and exploring opportunities using IQRF technology. Microchip is committed to making it easy for designers to add wireless connectivity to its products across a broad and expanding range of standards and protocols and has recently become a member of the IQRF Alliance to support this compelling option for connecting embedded systems. The cooperation of the individual members enables them to develop new applications, installations and systems and combine them via IQRF wireless technology. This provides a faster and much more effective method of bringing products to the market. Easy interoperability is the key to successful implementation of IQRF-based mesh networks. All of this makes wireless devices and solutions much more flexible, cost-effective and usable for more customers, widely.

## From a Smart City to a Smart Conference Center

IQRF technology is aiding in the implementation of applications such as smart cities and smart buildings. At the [OpenStack Summit](#) held in April in Austin, Texas, more than 7,500 developers from around the world attended a “[Building a Smart City with IoT](#)” presentation by Jakub Pavlík from [tcp cloud](#). He briefly introduced a smart city pilot project that was implemented in Pisek in the Czech Republic as an example of how IQRF technology can be used to collect a wide range of data. However, to make this technology more real to the audience, [tcp cloud](#) and several other members of the IQRF Alliance

had created a wireless IQRF mesh network consisting of 20 environmental sensors in just three weeks, prior to the conference. These sensors were installed throughout the Austin Convention Center with an area of 881,400 gross square feet. Data was collected in real time throughout the network by a Raspberry Pi® and then sent to servers located in the Czech Republic using Docker, OpenStack, Kubernetes and OpenContrail technologies. This data was not only displayed via a Graphical User Interface (GUI), but also made available to developers via the platform’s datacenter for further processing. This is just one of many examples of how IQRF technology can be implemented. For more information about this open-source IoT platform, visit the [tcp cloud blog](#).

Also visit the [IQRF Alliance website](#) to learn more about the technology and review additional case studies. Featured projects vary from bee hive weight scales to automated heating, to smart parking and more. The IQRF Alliance also organizes the [IQRF Conference](#) where leading companies such as Microchip, Microsoft, IBM, Intel and O2 IT Services and Czech Republic demonstrated their solutions for smart cities and the IoT.

If you are ready to get started with using IQRF technology in your mesh networking application, the DS-START-03 Starter Kit for Wireless Mesh Networks from MICRORISC can be ordered from [microchipDIRECT](#). 



### Temperature Sensors Target Cold and Outdoor Applications Down to $-40^{\circ}\text{C}$

- Remote temperature measurement
- 2- to 4-channel devices
- Can measure offboard



# From Zero to the IoT

DESIGN CORNER

## Connected MCU Course and Lab Helps Universities Make the Move to 32-bits

Assisting professors in their quest to forge the next generation of engineers, Microchip's Academic Program offers many unique benefits and resources for integrating Microchip products and technologies into university-level engineering programs. While many professors are using Microchip's 8-bit PIC® microcontrollers in their introductory electrical engineering classes, migrating to 32-bit devices is becoming a more pressing consideration as the Internet of Things (IoT) continues its rapid expansion. The connectivity demands of emerging cloud-based applications require more capable architectures to implement the required communications stacks. Therefore, the need to teach engineering students the more advanced concepts that are involved in developing connected embedded control systems is becoming even more vital.

To help ease this transition for educators and students alike, Microchip, Imagination Technologies, and Digilent, Inc. joined forces to develop **The Connected MCU Lab** through their respective academic programs. This semester-long course, which is available to universities worldwide, is designed as an introductory MCU course intended to take students from zero to the IoT using the popular and powerful **PIC32MZ** MCU, which incorporates a 32-bit MIPS M-Class CPU from Imagination,

as well as Microchip's suite of development tools. This course provides students with everything they need to design innovative IoT projects and also gives them valuable experience using professional-level tools that will arm them with relevant and marketable skills as they enter the workforce.

## A Fresh, Jargon-Free Approach

Targeting undergraduate students in electronic engineering or computer science, the course material was designed and developed by Dr. Alexander Dean of North Carolina State University. Assuming only basic familiarity with programming in C and presenting the key concepts with a fresh and jargon-free style, he guides students through MCU fundamentals, all the standard I/O functions, and exception processing using **MPLAB® X Integrated Development Environment (IDE)** and the **MPLAB XC32 Compiler**. He then introduces real-time task management using **FreeRTOS**, and finally, cloud connectivity using the **MPLAB Harmony** integrated software framework and **Creator Device Server**, part of the Creator IoT Framework from Imagination Technologies. Support materials include presentation slides for each module, student and instructor guides, exercises, tests and solutions.



(continued on page 23)



## On the Hardware Side

Most of the course modules include hands-on lab activities which are also provided with the course materials. The lessons are based on the **chipKIT™ Wi-FIRE** board from Digilent, which contains a PIC32MZ MCU and an MRF24WG0MA Wi-Fi® module. This feature-packed board also offers a maximum operating speed of 200 MHz, 2 MB of Flash memory, 512 KB RAM, high-speed USB connectivity, 43 I/O pins and much more, making it ideal for creating cloud-connected projects. A **chipKIT Basic I/O Shield** input/output expansion board provides an array of simple digital input devices such as switches and buttons, as well as digital output devices such as discrete LEDs

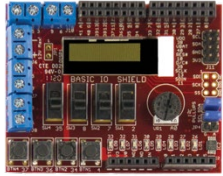

and high-current open FET drivers, plus a potentiometer and more advanced devices including an organic LED graphic display to provide additional learning opportunities. Also, a **PICkit™ 3 In-Circuit Debugger** is used to download programs from the development PC to the chipKIT Wi-FIRE board and to perform remote debugging.



## Ready to Make the Change?

If you are an educator who is interested in adding 32-bit microcontrollers to your curriculum, visit the **Imagination University Program website** to request an evaluation of The Connected MCU Lab. If you are not already a registered user, click on the “Register” link and be sure to use the check box at the bottom of the form to indicate that you want to register for the Imagination University Program. You will receive a verification email to activate your account and then you will be able to request the teaching materials from the Teaching Resources area. Feel free to pass this information along to other colleagues or educators who might also be interested in this curriculum.

Also, if you have not already done so, we urge you to join the **Microchip Academic Partner Program** to take advantage of the many resources, special discounts and customized support we provide to teachers and students who desire to use our wide range of solutions in their educational activities. 

## New OS81118 MOST® INICs Lead Automotive Networking into the Future

- Lowers system costs up to 50% with integrated coaxial physical layer
- Offers standard interface USB 2.0 high-speed port
- Also available with support for optical physical layer only





# Designing for the Hyperloop



## College Team Prepares to Push the Boundaries of Modern Technology in Developing Futuristic Transportation System

Contributed by Carnegie Mellon Hyperloop Team

College is a time for many things: making connections, pushing yourself intellectually, revolutionizing the transportation industry. At least that's what Carnegie Mellon University's (CMU) Hyperloop team is discovering.

A combination of undergraduate and graduate students, CMU Hyperloop is a multidisciplinary team of designers, engineers, and business students that has earned a spot among 30 teams from around the globe that are competing in the finals of the Space X Hyperloop Pod Competition. Their goal is to create a functional prototype of a Hyperloop transportation system comprised of a long, straight tube and an aerodynamic pod in which passengers sit. Conceptually, Hyperloop systems are intended to levitate and propel a pod at speeds reaching 200 meters per

second (450 miles per hour). While the system's construction and full-scale implementation may be largely theoretical as of now, SpaceX and the competing teams are looking to make this idea a reality.

The Carnegie Mellon team started work in the summer of 2015 and since then, their designs have undergone a finely tuned editing process. The most challenging question the CMU Hyperloop team faced was how to physically lift the pod. The team's initial answer to this question was to use air bearing technology as an innovative levitation strategy. Air bearings use pressurized air to create a thin, non-tactile interface between two bodies, namely, the pod and the Hyperloop track. However, the chamber itself would be largely devoid of air in an effort to maximize speed and to minimize drag forces, so the air bearing system was eventually discontinued in favor of a more passive, less energy-intensive levitation method: magnetism.

"In terms of engineering," said Karthik Chandrashekaraiyah, a master's student studying mechanical engineering, "there has been a [big] change. Previously, our design was inclined toward air bearings, but now we are looking to get it on full magnetism." In an earlier interview, Chandrashekaraiyah said that "once the levitation system is figured out, we can build every system around it." This holds true now, as the Carnegie Mellon team's pod design has seen a hefty amount of change in the past two months. The air bearing system required an air compressor, a

*(continued on page 25)*



motor and a large battery—all which weighed the pod down significantly. There was also the question of how to achieve just the right balance between low-drag, low-pressure conditions and having enough air in the tube to physically levitate the pod.

Now, the team's design is focused on aerodynamics and lightness. According to Chandrashekaraiyah, the team has been “making the pod as compact as possible.” The team was able to do away with the motor and the compressor and effectively shrink down the battery by switching to passive magnetism as their medium of levitation. “[The pod] has become more efficient...lighter, and...faster. We are aiming to achieve [speeds of] 200 meters per second,” which equates to roughly 450 miles per hour. The current pod design prioritizes speed and efficiency; “Previously, we were using lateral wheels for stability, but now there will be no part touching the ground, so there will be no friction at all,” said Chandrashekaraiyah.

When asked about the benefits of passive magnetism, Chandrashekaraiyah said that “if you attach magnets to any body and the propulse to a speed, it creates levitation force. In this way, you don't need to power any of the components here; you just have to attach magnets to the pod.” This passive mechanism beats out the previous air bearing system in terms of both utility and practicality; the air bearing system would have been both loud and physically/energetically cumbersome.

Since the team has spent much of the past year exploring the best and most viable options for their pod design, there was a good amount of prototyping that came before these final design plans. Much of this prototyping was aided by “Microchip's microcontrollers and CAN transceivers, [which]

allowed us to prototype a lot of different electronics architectures and implementations before committing to our present system,” said Suyash Bhatt, a junior electrical and computer engineering student. “Microchip's development tools have significantly aided us in prototyping and testing our pod's electrical system,” said Justin Rodenburg, also a junior electrical and computer engineering major. “They provide a simple, user-friendly interface which allowed us to efficiently test and design iterations of our pod's systems. Overall, the development boards have proven extremely useful in the prototyping phase of our design.”

CMU Hyperloop isn't just looking to engineer the winning design for the SpaceX competition. “We're considering building a full-scale Hyperloop,” said Chandrashekaraiyah in an earlier interview. This is one reason that the Carnegie Mellon team is pushing scalability of their design as a priority. While this contest is largely an exercise in pushing the boundaries of modern technology and actualizing theoretical systems, the CMU team remains optimistic that their efforts throughout the past year and continuing to the contest finals this summer will one day manifest themselves in a real-life transport system. “You feel very delighted that you're doing something that's never been done before,” said Chandrashekaraiyah.

As of now, the CMU Hyperloop team has raised over \$100,000 in sponsorship and crowdsourced funding. To find out more about the team, visit [www.cmuhyperloop.com](http://www.cmuhyperloop.com). 

## Turn Your Tablet or Computing Device into an Oscilloscope Display

Compact and portable, the Velleman WFS210 is the world's first WLAN dual-channel digital storage oscilloscope geared towards iOS® and Android™ tablets. Order it today from microchipDIRECT.

**microchip**  
**DIRECT**





# Boost Your Connection and Security Speed

Hardware Accelerators for Security  
Functions and a Free IPv6 Software Stack



The feature-packed PIC32MZ series offers large Flash and RAM arrays with a healthy mix of peripherals enabling innovative connected solutions. They are supported by the MPLAB® Harmony Software Development Framework featuring software packages to support connectivity options including USB, TCP/IP Networking and Wi-Fi®, as well as additional libraries for cryptographic functions. On-chip hardware accelerators on the PIC32MZ-EF series offer up to 8x speed on SHA-256 Hash functions, enabling higher throughput in secured web server type applications.

A free, certified IPv6 stack is also available, which includes provisions for cross compatibility as an IPv4/IPv6 hybrid stack and is implemented through the graphical interface in MPLAB Harmony, v1.04 and higher.

- Up to 200 MHz performance
- Up to 2 MB Flash and 512 KB RAM
- Hi-Speed USB, CAN and 10/100 ENET
- Hardware crypto accelerators for AES and SHA

[www.microchip.com/PIC32\\_IoT](http://www.microchip.com/PIC32_IoT)



PIC32MZ with Floating  
Point Unit (FPU) Embedded  
Connectivity Starter Kit with  
Crypto Engine (DM320007-C)

