



daisy.

● Quick Start Guide to Your IP Phone



SPA 300 Series IP Phone Models SPA 301 and SPA 303

- SPA 300 Series IP phone
- Phone stand
- RJ-45 Ethernet cable
- Quick start guide
- Product CD-ROM

● Welcome

Thank you for choosing the Cisco SPA 300 Series IP Phone. This guide describes how to physically install your Cisco SPA 300 Series IP Phone and how to perform some basic tasks.

Before you begin

Make sure that your internet telephony service is configured and active. For example, your phone will be registered to a device, such as a Cisco Unified Communications 500 Series or a third-party application server, that provides your phone service.

Getting to know your Cisco SPA 301 IP Phone



#	Phone feature	Description
1	Receiver	Pick up to place or answer a call.
2	Message waiting/status indicator	The LED colour indicates the phone or message status. A solid red LED indicates that you have a new voicemail message.
3	Ringer button	Push to turn ringer on or off.
4	Voicemail button	Press to access voicemail (this must be set up by your phone administrator).
5	Flash button	Press to place a call on hold and open another line.
6	Redial button	Press to redial the last number called.
7	Volume	Press repeatedly to increase the volume of the handset when the receiver is off the hook, or the ringer volume when the receiver is in place.
8	Keypad	Use to dial phone numbers.

● Installing the Cisco SPA 301 IP Phone

Step 1 Turn the phone body over to expose the ports on the back of the unit.

Step 2 Insert the long end of the phone cord into the handset port on the phone body that is marked with a phone symbol (labelled 2).



Step 3 Insert the other end of the phone cord into the port at the bottom of the receiver.

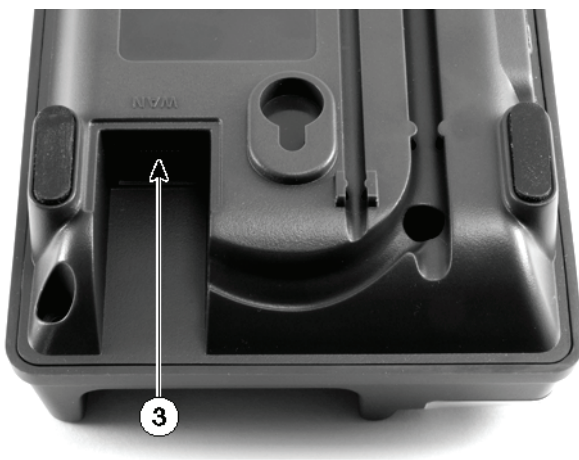

Step 4 Connect your phone to the network using one of the methods below:

- **Using an Ethernet connection**

Insert one end of the Ethernet cable into the network port on the phone body marked 'WAN' (labelled 3).

Insert the other end of the Ethernet cable into the appropriate device, such as a network switch, on your network.

- **Using a wireless connection**

You can use a Cisco WBP54G Wireless-G Bridge with the IP phone to create a wireless connection between the phone and the network. See the WBP54G documentation on www.cisco.com for more information.

Step 5 Insert one end of the power cord into an outlet and insert the other end of the power cord into the power port on the phone body (labelled 1).

NB To power the phone through the Ethernet connection, use the optional Cisco POES5 5-Volt Power Over Ethernet Splitter accessory. See the Cisco POES5 documentation on www.cisco.com for more information.

Step 6 (Optional) To install the phone on a vertical surface, use the Cisco MB100 Wall Mount bracket. See the Cisco Small Business IP Phone SPA 300 Series User Guide (SIP) or the Cisco Unified Communications Manager Express for the Cisco Small Business IP Phone SPA 300 Series documents on www.Cisco.com for more information.

After your phone is successfully connected to the network and receives a basic configuration, you should hear a dial tone when picking up the receiver.

● Getting to know the Cisco SPA 303 IP Phone

#	Phone feature	Description
1	Receiver	Pick up to place or answer a call.
2	Message waiting indicator	Displays solid red when you have a new voicemail message. Flashes red during an incoming call or when the phone's firmware is being updated.
3	LCD screen	Displays date and time, phone station name, line extensions, and soft key options.
4	Line keys	Indicates phone line status - see below for colour codes.
5	Soft key buttons	Press a soft key button to perform the action shown on the label on the LCD screen above. Soft keys vary depending on your phone system. See your phone user guide for more information.
6	Navigation buttons	Press an arrow to scroll left, right, up or down through items shown on the LCD screen.
7	Messages button	Press repeatedly to increase the volume of the handset (when the receiver is off the hook) or ringer volume (when the receiver is in place).
8	Hold button	Press to access voicemail (must be set up by your phone system administrator).
9	Set-up button	Press to access a menu to configure features and preferences (such as your directory and speed dials), access your call history, and set up functions (such as call forwarding).
10	Mute button	Press to mute or unmute the phone. When the phone is muted, the button glows red. A flashing mute button indicates the network connection cannot be found.
11	Headset button	Push to turn the headset on or off. When the headset is on, the button glows green.
12	Volume button	Press '+' to increase the volume and '-' to lower the volume of the handset, headset, speaker (when the receiver is off the phone), or ringer volume (when the receiver is on the phone).
13	Speaker button	Push to turn the speaker on or off. When the speaker is on, the button glows green.
14	Keypad	Use to dial phone numbers, enter letters and choose menu items.



Line key colour codes

Green - Line is idle

Red (steady) - Line is active or in use

Red (blinking) - Line is on hold

Orange - Line is unregistered and cannot be used

Note - Line key colours depend on your phone system and can vary.

These keys can also be programmed by your phone system administrator to perform functions such as speed dial, call pickup, or monitoring and extension.

● Installing the Cisco SPA 303 IP Phone

Use these steps to install the phone and connect it to your network.

Step 1 Turn the phone body over to expose the ports on the back of the unit.

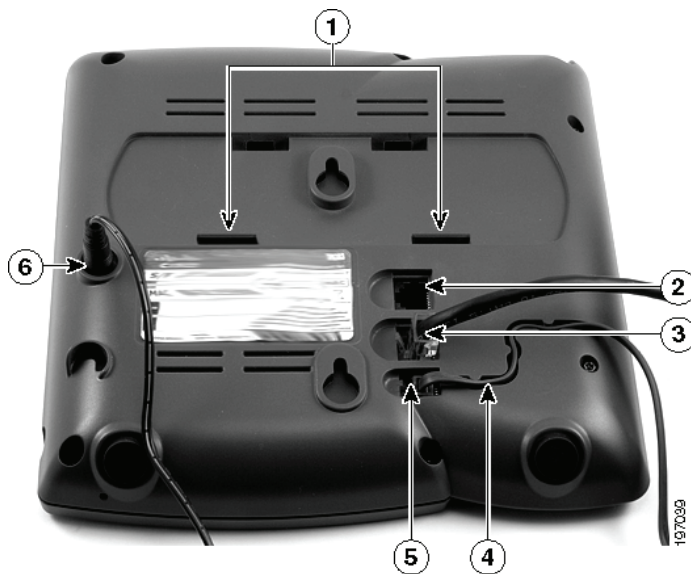

Step 2 Insert the long end of the phone cord into the receiver port on the phone body that is marked with a phone symbol (labelled 5).

Step 3 (Optional) Route the phone cord through the cable slot (labelled 4).

Step 4 Insert the other end of the phone cord into the port at the bottom of the receiver.

Step 5 Connect the phone stand by lining up the tabs on the stand with the slots on the phone body. Slide the bottom tabs into the lower slots on the phone body (labelled 1) and lightly press down on the stand. It should easily slide into the upper stand slots.
Do not force.

Step 6 Connect your phone to the network using one of the methods below:

- **Using an Ethernet connection**

Insert one end of the Ethernet cable into the network port on the phone body marked 'SW' (labelled 3).

Insert the other end of the Ethernet cable into the appropriate device, such as a network switch, on your network.

- **Using a wireless connection**

You can use a Cisco WBP54G Wireless-G Bridge with the IP phone to create a wireless connection between the phone and the network. See the WBP54G documentation on www.cisco.com for more information.

Step 7 Insert one end of the power cord into an outlet and insert the other end of the power cord into the power port on the phone body (labelled 6).

NB To power the phone through the Ethernet connection, use the optional Cisco POES5 5-Volt Power Over Ethernet Splitter accessory. See the Cisco POES5 documentation on www.cisco.com for more information.

Step 8 (Optional) To provide network access to a PC, connect one end of an additional Ethernet cable (not provided) to the PC port on the back of the phone body (labelled 2). Connect the other end of the Ethernet cable to the network port on your PC.



After your phone is successfully connected to the network and receives a basic configuration, you should hear a dial tone when picking up the receiver or pressing the speaker phone button, and your phone line keys should glow green (depending on your phone system).

● Using your IP phone

Placing or answering calls

Pick up the receiver and dial (SPA 301/303), or press the speaker or headset button (SPA 303).

Putting a call on hold

To put a call on hold, press the Flash (SPA 301) or Hold (SPA 303) button. The caller hears a series of three rapid beeps or music while on hold. To resume the call, press Flash (SPA 301) or the flashing red line button for the call (SPA 303).

Ending a call

If you are using the receiver, hang up (SPA 301/303). If you are using the speakerphone function (SPA 303), press the speaker button. If you are using the headset (SPA 303), press the headset button.