

**ORSCO® Continuous Spray System:**

# **A True Innovation in Oil Lubrication Technology**



**The ORSCO Philosophy:**

**“The best approach to lubrication is to deliver the least amount of lubricant required. Anything else is wasted.”**

# A True Innovation in Oil Lubrication Technology

The major difference between ORSCO oil lubrication systems and other lubrication technologies is the use of a continuous, ultra-fine, non-mist delivery of lubricant. The ORSCO system can spray minute quantities of lubricant for a selected duration of time.

The ORSCO systems deliver minute quantities of oil, resulting in significant cost savings by decreasing lubricant consumption, reducing product contamination and eliminating under/over lubrication.

In critical applications where cleanliness is a must, the ORSCO system achieves exceptional performance.

The system is successfully used in Plastic Film, Textile, Food Processing, Baking, Automotive, Metal Stamping, Fiberglass, Electronics, Can Decorating, Mining, Pulp and Paper, Machine Tool and many other industries.

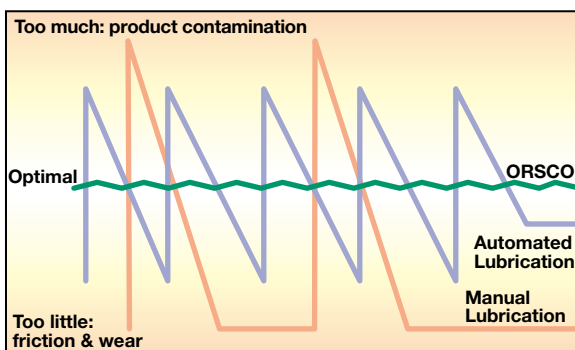

## Eliminates the Too Much—Too Little Factor

The ORSCO system lubricates more effectively than traditional cyclic lubrication systems or manual lubrication. With the ORSCO system you are always at the optimum lubricating range.

## Eliminates Contamination

ORSCO's patented, precision spray nozzles lubricate exactly where required with an accurate amount of lubricant to reduce product contamination. Unlike traditional oil mist systems, ORSCO's spray technology eliminates environmental contamination typically caused by "stray mist."

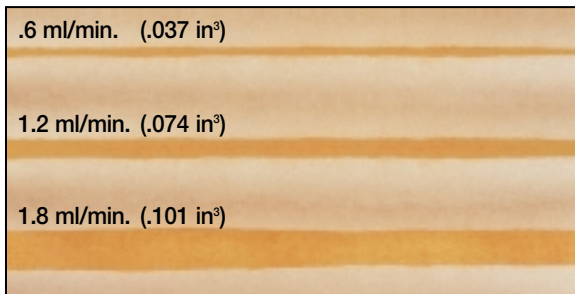

Typical ORSCO Spray patterns

## Continuous, Consistent Spray

ORSCO systems are capable of dispensing one drop of lubricant continuously for a period exceeding four minutes. No change in spray pattern occurs even after another drop of lubricant is injected.

 This red dot is the actual size of a drop of oil (.03ml/0.002 cu<sup>3</sup>) the ORSCO system can deliver in a continuous consistent spray pattern up to four minutes.

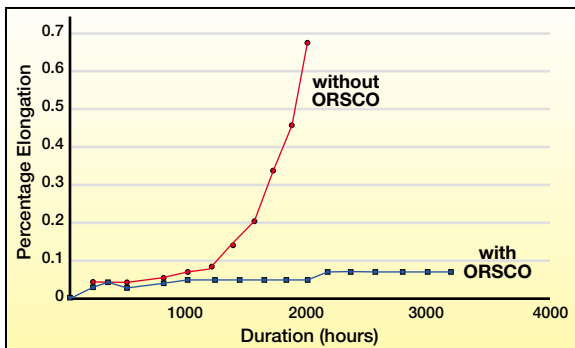

## Dramatically Increases Life Expectancy of Lubricated Devices

Percentage elongation (shown on the chart for chains) is maintained at a consistent low level, even after 3,000 hours of use. The result is five to ten times longer life expectancy of the lubricated devices.

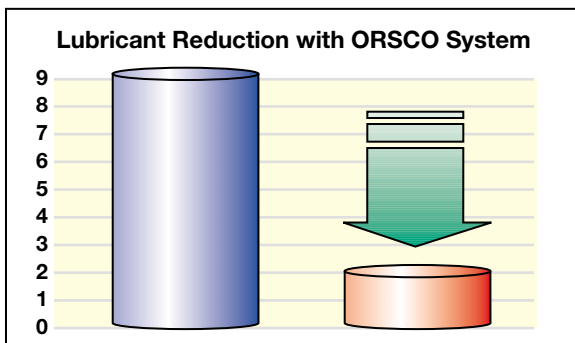

## Up to 90% Lubricant Reduction

If you calculate the actual amount of lubricant that is needed for a particular application, the majority of automated and manual lubrication systems over lubricate. Because ORSCO systems lubricate continuously with an ultra-fine, non-misting spray, only the exact amount of oil required to lubricate is used.



## ORSCO Products and Services

### Series 150

A standard and easy to install system for up to eight lubrication points with multiple variations to choose.

### Series 200

A customized system that provides basic monitoring with unlimited lubrication points.

### Series 300

An advanced engineered lubrication system with complete fault monitoring.

### Coaxial Delivery Systems

Point of use lubrication delivery system for air tools, cylinders, pumps, guns, drills and motors.

### Services

ORSCO design services are available for complex systems and for special applications. If necessary, ORSCO will custom design nozzles or systems specific to the particular application.

ORSCO has been part of the Lincoln Industrial product family since 1998.

### Technical Information

ORSCO, Inc.

Phone: 1-810-997-0300

Fax: 1-810-997-2072

# ORSCO lubrication systems

- Extend chain life and reduce oil consumption
- Short-term return on investment (ROI)
- Cleaner conditions, less downtime and overall energy savings



# ORSCO series 170



The secret of the ORSCO series 170 is its unique ability to provide the right amount of lubricant, at the right location and at the right time, by delivering a small amount of lubricant on a continual and controlled basis. There are no worries about reliability or durability as the ORSCO series 170 has been tested at the maximum injector rate for millions of cycles.



## Pulp and paper industry

### Spray nozzle advantage: Cleaning effect

Applying lubricant in a continuous fashion provides the best on-going continual maintenance for your chain and keeps all the moving parts as clean as possible, as shown.

## The ORSCO concept

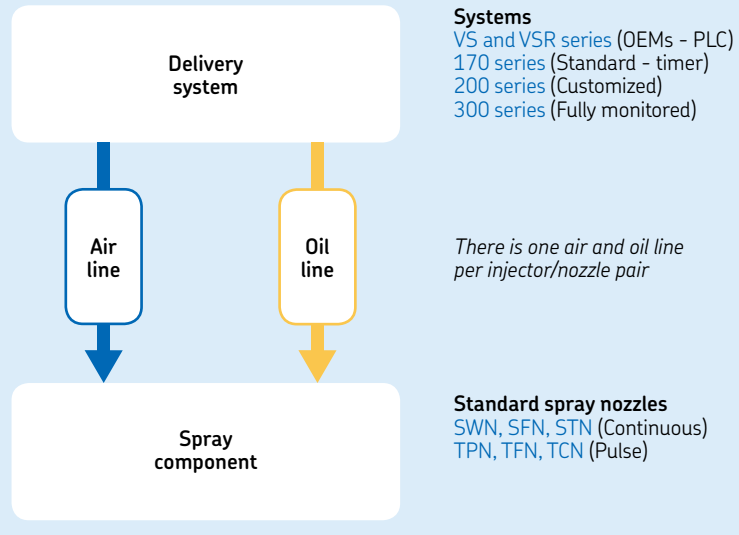

## ORSCO system components

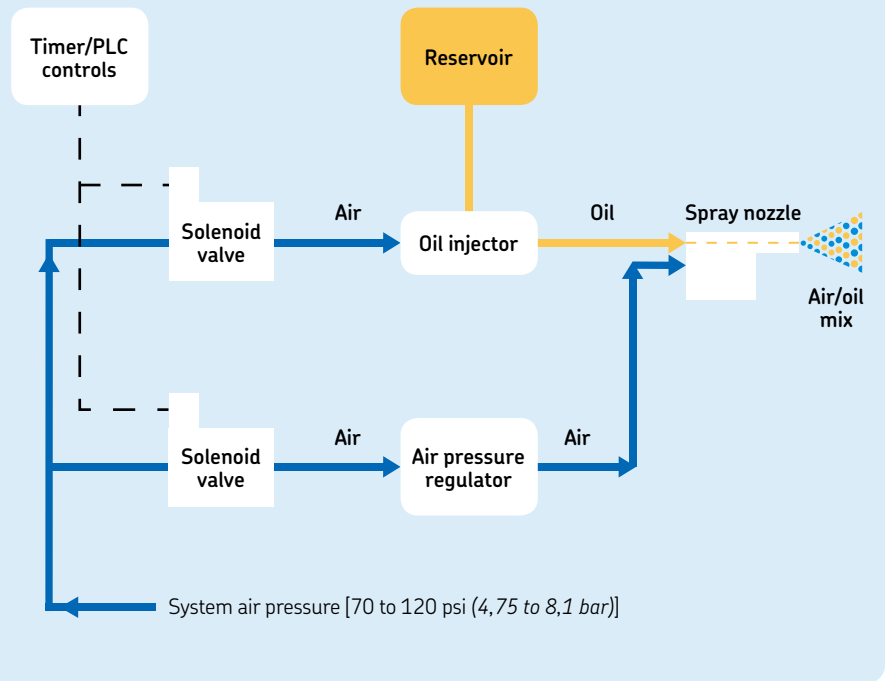

# Product features

## A complete system

- Original equipment manufacturer (OEM) or installed on site
- Combines controls, valves stack and reservoir

## High-output capacity

- Half drop (0.015 cc)
- Two drop (0.060 cc)
- Can deliver up to four drops per second (combined injector output) for large amounts of lubrication
- Available in both non-adjustable and adjustable versions

## Compact and easy to maintain

- Manifold design, compact
- Can service part of assembly if necessary
- Easy to set up

## Applications

- High-speed conveyors
- Baking and processing ovens
- Overhead conveyors
- Lubricate up to 16 points with one system
- Numerous control options
- Part lubrication
- Material coverage

## Features and benefits

- Fixed volume delivery improves lubricant control
- High injector cycle rate (up to 1 Hz) can accommodate applications requiring large amounts of lubricant
- Three-piece reservoir design makes fluid levels easy to see and the component easy to clean and field repair
- Compact modular design with minimal external piping is ideal for OEM applications
- Patented spray nozzle design
- Easily adaptable modular package

## Modular packages for OEMs and end-users

### Valve stack (VS) series

The valve stack, the heart of the ORSCO family of lubrication products, comes standard with one control network per stack and feeds up to eight injectors. This is a great lubrication solution when matched with a customer's programmable logic controller (PLC) and existing fluid source.

Note: Filter pressure switch is not standard with the VS series product

### VS series (non-adjustable)



### VS series (adjustable)

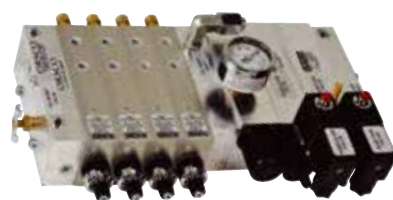

### Valve stack-reservoir (VSR) series

By adding a reservoir and a filter pressure switch, this package comes ready to work with a customer's timer or programmable logic controller (PLC).

### VSR series



# Ideal for many industries



*Pulp and paper industry*



*Beverage industry*



*Textile industry (tenter frame applications)*



*Waste water treatment*

## **Series 170 system**

A standard and easy-to-install system for up to 16 lubrication points with multiple variations to choose.

## **ORSCO series 200 and 300**

Series 200 is available for custom solutions requiring over 16 points of lubrication.

Series 300 is for real-time pressure monitoring of lubrication system.



# Products



Food processing/baking industry



Automotive industry



Material handling industry

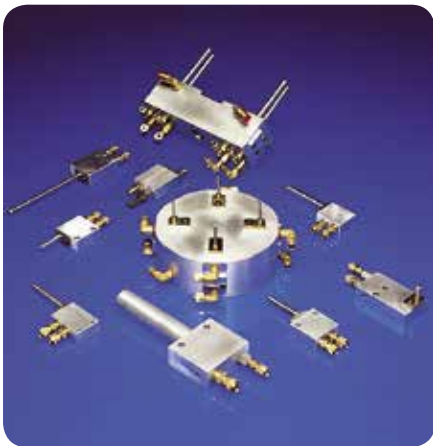

## Customized oil spray nozzles

If necessary, ORSCO will custom design nozzles or systems specific to the particular application.

## At ORSCO . . .

- We don't make lubricants, we make lubricants work better!
- We don't make chains, we make chains last longer!
- We don't make machines, we make machines more productive!



## Industrial applications

Industry	Series 170	Series 200	Series 300
Assembly	•	•	•
Automotive	•	•	•
Baking	•	•	
Beverage	•	•	
Fiberglass	•	•	
Food processing	•	•	
Gypsum	•	•	
Industrial ovens	•	•	
Machine tool	•	•	•
Material handling	•	•	
Plastic	•	•	• <sup>1)</sup>
Pulp and paper	•	•	
Textile	•	•	• <sup>1)</sup>
Waste water	•	•	

<sup>1)</sup> Tenter frame applications



# Patented precision delivery nozzles

Choose from three tip lengths and three spray patterns for versatility in any continuous or pulsed spray design application. These nozzles feature 1/4-20 tapped (#10 screw clearance) mounting holes and durable aluminum construction.

## Continuous-spray nozzles



SWN IL type



SWN LP type

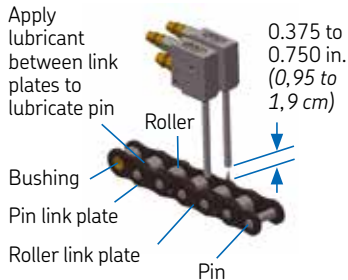

## Order number configurator

SWN - IL - NC - 90 - 2  
 TPN - LP - NC - 00 - 3

### Standard nozzles

SWN = Continuous spray  
 TPN = Pulse spray

### Body style

IL = In line  
 SS-IL = Stainless steel in line  
 LP = Low profile  
 SS-LP = Stainless steel low profile

### Fittings

NC = Nylon compression fitting - standard  
 NY = Nylon push in tube fitting  
 CS = Carbon steel fitting (steel tubing)  
 SS = Stainless steel fitting (steel tubing)  
 XX = No fittings

### Oil lines

Nylon - 3/16 in. tubing  
 Steel tube - 1/8 in. OD tubing

### Air lines

Nylon - 1/4 in. tubing  
 Steel tube - 1/4 in. OD tubing

### Spray pattern angle

00 = 0° (straight)  
 45 = 45°  
 90 = 90°

### Tip length

1 = 1 in.  
 2 = 2 in.  
 3 = 3 in.

For custom nozzle design, contact your ORSCO representative.

## Other popular nozzle families



**TPN standard**  
 Pulse-Spray Nozzle  
 Assembly applications and slow moving chains



**TFN**  
 Pulse-Spray 360° Fan Nozzle  
 Bore lube and general assembly applications



**TCN**  
 Pulse-Spray Cone Nozzle  
 Engine and general assembly applications



**SWN standard**  
 Continuous-Spray Nozzle  
 Chain/gears/exposed bearings/assembly applications



**SFN**  
 Continuous-Spray 120° Fan Nozzle  
 Metal stamping/metal forming/food applications



**HFN**  
 Continuous-Spray High-Flow Nozzle  
 Spindle applications

# Packaged systems

## 170 series

A standard and easy-to-install system for up to 16 lubrication points. Systems include an internal timer to control injector cycle rate.

**Note:** Dual network indicates that half of the lubrication points are controlled by their own timer. Package includes appropriate number of spray nozzles of the type SWN-LP-NC-00-3, stainless steel nozzle mounting bracket and 25 ft. (7,6 m) nylon lines per lubrication point.

### Series 170 lubrication systems

Model	Injector size <sup>1)</sup>	No. of networks	No. of injectors	Voltage <sup>2)</sup> (USD)
<b>170-512AO</b>	0.015	1	2	120 V AC
<b>170-514AO</b>	0.015	1	4	120 V AC
<b>170-524AO</b>	0.015	2	4	120 V AC
<b>170-528AO</b>	0.015	2	8	120 V AC

<sup>1)</sup> For double-drop injectors replace "5" with a "2" (i.e., 170-214AO)

<sup>2)</sup> For 24 V DC voltage replace "A" with "D" (i.e., 170-524D0)

## VSR series

ORSCO valve stack with reservoir and filter regulator/pressure switch. The system comes ready to work with a customer's timer or PLC. Package includes appropriate number of spray nozzles of the type SWN-LP-NC-00-3, stainless steel nozzle mounting bracket and 25 ft. (7,6 m) nylon lines per lubrication point.

Note: Packaged systems are for continuous spray applications only.

### Series VSR lubrication systems

Model	Injector size <sup>1)</sup>	No. of networks	No. of injectors	Voltage <sup>2)</sup>
<b>VSR-512AO</b>	0.015	1	2	120 V AC
<b>VSR-514AO</b>	0.015	1	4	120 V AC
<b>VSR-524AO</b>	0.015	2	4	120 V AC
<b>VSR-528AO</b>	0.015	2	8	120 V AC

<sup>1)</sup> For double-drop injectors replace "5" with a "2" (i.e., VSR-214AO)

<sup>2)</sup> For 24 V DC voltage replace "A" with "D" (i.e., VSR-524D0)

Please contact ORSCO to quote your specific application.



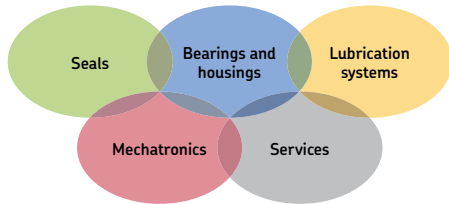

**The Power of Knowledge Engineering**  
 Combining products, people, and application-specific knowledge, SKF delivers innovative solutions to equipment manufacturers and production facilities in every major industry world-wide. Having expertise in multiple competence areas supports SKF Life Cycle Management, a proven approach to improving equipment reliability, optimizing operational and energy efficiency and reducing total cost of ownership.

These competence areas include bearings and units, seals, lubrication systems, mechatronics, and a wide range of services, from 3-D computer modelling to cloud-based condition monitoring and asset management services.  
 SKF's global footprint provides SKF customers with uniform quality standards and worldwide product availability. Our local presence provides direct access to the experience, knowledge and ingenuity of SKF people.

## Other automated lubrication systems (ALS)



### EOS system

A low-cost, economical system for precise metered quantities of oil to reduce chain and sprocket wear.



### VSP system

A pneumatic-only controlled VSR made especially for applications prohibiting the use of electrical systems.



### Custom controls

Custom controls designed to meet special application requirements.

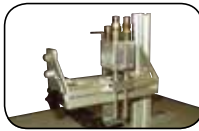

### Accessories

Spring-loaded bracket and other accessories such as fiberglass enclosures and stainless steel fittings available only from ORSCO.

Please contact:

**ORSCO, Inc.**

14165 Rick Drive

Shelby Township, MI 48315 USA

Tel. +1 (586) 997-0300

© SKF is a registered trademark of the SKF Group.

© Lincoln and ORSCO are registered trademarks of Lincoln Industrial Corp.

© SKF Group 2014

The contents of this publication are the copyright of the publisher and may not be reproduced (even extracts) unless prior written permission is granted. Every care has been taken to ensure the accuracy of the information contained in this publication but no liability can be accepted for any loss or damage whether direct, indirect or consequential arising out of the use of the information contained herein.

PUB LS/P2 14654 EN · May 2014 · Form 442919



## **ORSCO® Series 150**

# **A Standard Packaged Lubrication Solution**



**The ORSCO Continuous Spray Lubrication Systems drop lubricant use up to 90% and help eliminate oil waste or air contamination.**

# An Easy To Install System For Up To Eight Lubrication Points With Multiple Control Options Available

### System Features

- Lubricates up to eight lubrication points
- Adjustable lubricant output volume
- One dedicated positive displacement injector per spray nozzle
- Viscosity range 100 to 2000 SUS/460 to 9200 CST
- System mounted remote from nozzles (up to 60 feet/18 m)

We designed our Series 150 as an engineered standard package. The Series 150 is simple to assemble and install, as well as easy to operate and maintain. With the different control options and nozzle quantities it is a flexible application oriented package.

### Control Options

- C Option:** Customer controlled option with a terminal strip for connection to PLC, PC or machine control.
- T Option:** Incorporates the ORSCO TDR-11 timer module to control the injector timing for volume adjustment.
- R Option:** Incorporates the ORSCO TDR-11 timer module to control the injector timing. Timer relays are used to control spray cycle timing.

### Dimensions

Size: 18.5" x 19.63" x 7.44"  
470mm x 500mm x 190mm

### Power Options

AC and DC power options.

### Nozzles

ORSCO's patented precision spray nozzles apply lubricant with a unique non-misting air-oil blend for maximum effectiveness. Nozzles are available as a standard or custom designed specific for special applications.

### Typical Applications

- Chain Lubrication
- Fin Mill
- Light Assembly
- Conveyors, etc.

### Technical Information

ORSCO, Inc.  
Phone: 1-810-997-0300  
Fax: 1-810-997-2072

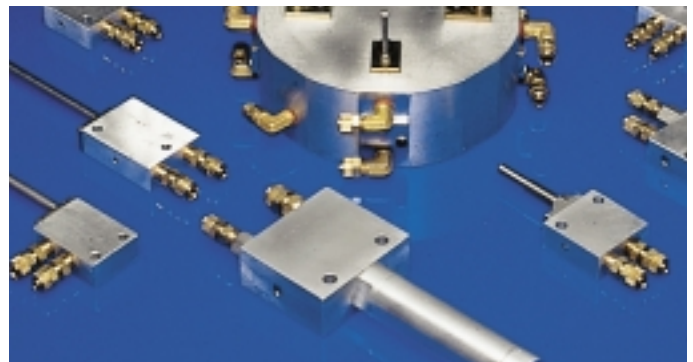

## **ORSCO® Series 200**

# **Custom Designed Oil Lubrication Systems**



**The ORSCO systems are a long term financial investment for your applications. With a short return on investment, the ORSCO system is an ideal solution for your lubrication needs.**

**ORSCO® Series 200**

# ***A Fully Customized System For Unlimited Lubrication Points***

## **System Features**

- Basic fault monitoring
- Unlimited lubrication points
- Lubricant volume adjustment capabilities
- Spray nozzles operate with regulated air pressure as low as 5 psi (.35 bar)
- Dispenses lubricant exactly where it's needed—even hard to penetrate areas
- Continuous delivery or intermittent operation



The Series 200 system is a customized package designed for unlimited lubrication points.

## **Dimensions**

Size: Varies per the number of nozzles required

## **Fault Monitoring**

- Low oil reservoir fault
- Low air pressure for the system

## **Nozzles**

ORSCO's patented precision spray nozzles apply lubricant with a unique non-misting air-oil blend for maximum effectiveness. Nozzles are available as a standard or custom designed specific for the particular application.

## **Typical Applications**

- Assembly lubrication
- Accurate, clean delivery of most fluids
- Chain lubrication, etc.

## **Technical Information**

ORSCO, Inc.  
Phone: 1-810-997-0300  
Fax: 1-810-997-2072



**LINCOLN**  
**INDUSTRIAL**

One Lincoln Way  
St. Louis, MO 63120-1578  
USA

Phone 1-314-679-4200  
Fax 1-314-679-4359  
www.lincolnindustrial.com

Form 442880  
© Copyright 1999  
Printed in U.S.A.



**A Pentair Company**

## **ORSCO® Series 300**

# **Fully Monitored Oil Lubrication Systems**



**The ORSCO Series 300 Lubrication System provides complete monitoring of both air and oil lines for 100 percent delivery verification.**



## ORSCO® Series 300

# An Advanced Engineered Oil Lubrication System With Complete Monitoring Capabilities

### System Features

- Unlimited lubrication points
- No limitations on spray direction
- No change in spray pattern, even when another drop of lubricant is injected
- Capable of dispensing one drop of lubricant continuously for over four minutes
- Full fault monitoring capabilities

The Series 300 System is the most advanced of the ORSCO systems available. This customized system allows ORSCO engineers to design to your specifications. The addition of a PLC gives the Series 300 the edge over other systems, allowing for complete delivery verification. With capability for unlimited lubrication points, the Series 300 can work with any application.

### Dimensions

Size: Varies per the number of nozzles required

### Fault Monitoring

- Reservoir level condition
- Low air/oil pressure in the line feeding the nozzle
- High air/oil pressure in the line feeding the nozzle
- Injector (pump) pressure spike verification

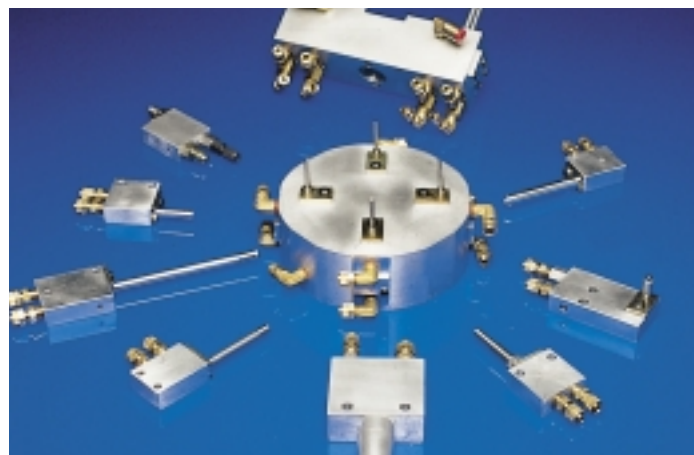

### Nozzles

ORSCO's patented precision spray nozzles apply lubricant with a unique non-misting air-oil blend for maximum effectiveness. Nozzles are available as a standard or custom designed specifically as required by the particular application.

### Typical Applications

- Assembly operations
- Critical chain applications
- High speed spindles, etc.

### Technical Information

ORSCO, Inc.  
Phone: 1-810-997-0300  
Fax: 1-810-997-2072

**ORSCO® Coaxial Systems**

**Precision Injector and Co-Axial  
Lubrication Assemblies**



**ORSCO systems are preferred for their reliability. When you have a job that needs to get done, ORSCO is the name you can trust for dependable lubrication.**

## Consistent—Dependable—Reliable

### System Features

- Point of use lubrication delivery
- High level of control
- Modular connectors for easy maintenance
- Central fill capability

ORSCO Coaxial systems provide oil injection for exact air tool lubrication.

### Benefits

- Proper lubrication of air tools
- Consistent torque
- Decrease in air tool maintenance
- Decrease in housekeeping costs

### Options

- Multiple air tool lubrication capabilities
- Suspension options (all tool rail types)
- Automatic or manual lubricant fill
- Standard or custom assemblies
- Hose selection options
- Tool end coupling type options
- Base assembly options

### Applications

#### Single Point

- Air tools (short cycle)
- Cylinders
- Pumps
- Rivet guns
- Air valves

#### Air Logic Lubricator

- Grinder air motors
- Dye mixer motor
- Air powered drills
- Long running air motors (run longer than one minute)

### Technical Information

ORSCO, Inc.

Phone: 1-810-997-0300

Fax: 1-810-997-2072



Hoses with Internal Capillary Tubes

Family of Coaxial-Components