

CONF ALL

AIRBUS
2, ROND POINT EMILE DEWOITINE
31700 BLAGNAC
FRANCE

The content of this document is the property of Airbus. All rights including copyrights are reserved.
It is supplied in confidence and commercial security on its contents must be maintained.

It must not be used for any purpose other than that for which it is supplied, nor may information contained in it be disclosed to unauthorized persons.

It must not be reproduced in whole or in part without permission in writing from the owners of the copyright. Requests for reproduction of any data in this document and the media authorized for it must be addressed to Airbus.

ATA SYSTEM: 36

**TITLE: PNEUMATIC - DISTRIBUTION - INSTALL NEW BLEED GIMBAL
STANDARD REFERENCE - LHS**

MODIFICATION No.:
114810L91112

ATA SYSTEM: 36

TITLE: PNEUMATIC - DISTRIBUTION - INSTALL NEW BLEED GIMBAL STANDARD REFERENCE - LHS

SUMMARY

This summary is for information only and is not approved for modification of the aircraft.

A. MODIFICATIONS

MODIFICATION CLASSIFICATION	
MAJOR	None
MINOR	114810L91112

NOTE: As per EASA IR 21, a minor change is one that has no appreciable effect on the mass, balance, structural strength, reliability, operational characteristics affecting the airworthiness of the product. All other changes are major changes.

B. REASON

(1) History

This Service Bulletin is issued to answer to quality assurance department has identified that a problem with internal interference of adjacent parts:

- Irregular welding of gimbal ring bush (raised and bumpy weld profile)
- Internal interference between bellows and gimbal rings (resistance between 7° and 8.5°)
- Damage to the inside diameter of the bellows assy membrane 8.5° gimbal (dent of outside of bellows).

(2) Objective/Action

This Service Bulletin consists in replacing a bleed gimbal Standard (STD) on Left Hand (LH) wing.

(3) Advantages

Accomplishment of this Service Bulletin cancels the requirements of Ref. SB A350-36-P029.

The accomplishment of this Service Bulletin will improve the gimbal quality.

(4) Operational/Maintenance Consequences

None

C. GENERAL EVALUATION

EVALUATION TABLE			
COMPLIANCE	RECOMMENDED	COST SAVING	NO
A/C OPERATION AFFECTED	NO	VENDOR SB	NO
CANCELS INSPECTION SB	YES	ETOPS AFFECTED	NO
PAX COMFORT AFFECTED	NO	POTENTIAL AD	YES
RELIABILITY AFFECTED	NO	STRUCTURAL LIFE EXTENSION	NO
LIFE LIMIT	NO	LINE MAINTENANCE AFFECTED	NO

NOTE: Service Bulletin recommended to be accomplished to prevent significant operational disruptions.

D. MAINTENANCE CONFIGURATION

No specific aircraft maintenance configuration required.

E. MATERIAL PRICE INFORMATION

(1) Modification

(a) Task set A350-A-36-XX-P023-01000-93AA-A Modification

MATERIAL PRICE INFORMATION TABLE			
MATERIAL SET	QTY PER A/C	PRICE PER A/C	MAIN PARTS
Part kit 36P023C01R01	1	4300.00 USD	Gimbal joint, E-seal

F. APPLICABILITY

This Service Bulletin is applicable to this (these) operator(s):

82W AAR AFR BAW CAL CCA CES CHH CPA CSC CSN DAL DLH ETD ETH EVE FBU FIN FJI FWI
HVN IBE JAL MAS MAU PAL QTR SAA SIA TAM THA VIR

G. CONCURRENT REQUIREMENTS

None

H. NATURE OF THE WORK

(1) Modification

(a) Task set A350-A-36-XX-P023-01000-93AA-A Modification

AIRCRAFT	YES
EQUIPMENT	NO

I. MANPOWER

(1) Modification

(a) Task set A350-A-36-XX-P023-01000-93AA-A Modification

MANPOWER	
TOTAL MAN-HOURS	7.75 h
ELAPSED TIME (HOURS)	5.25 h

J. GENERAL OVERVIEW

CONF ALL

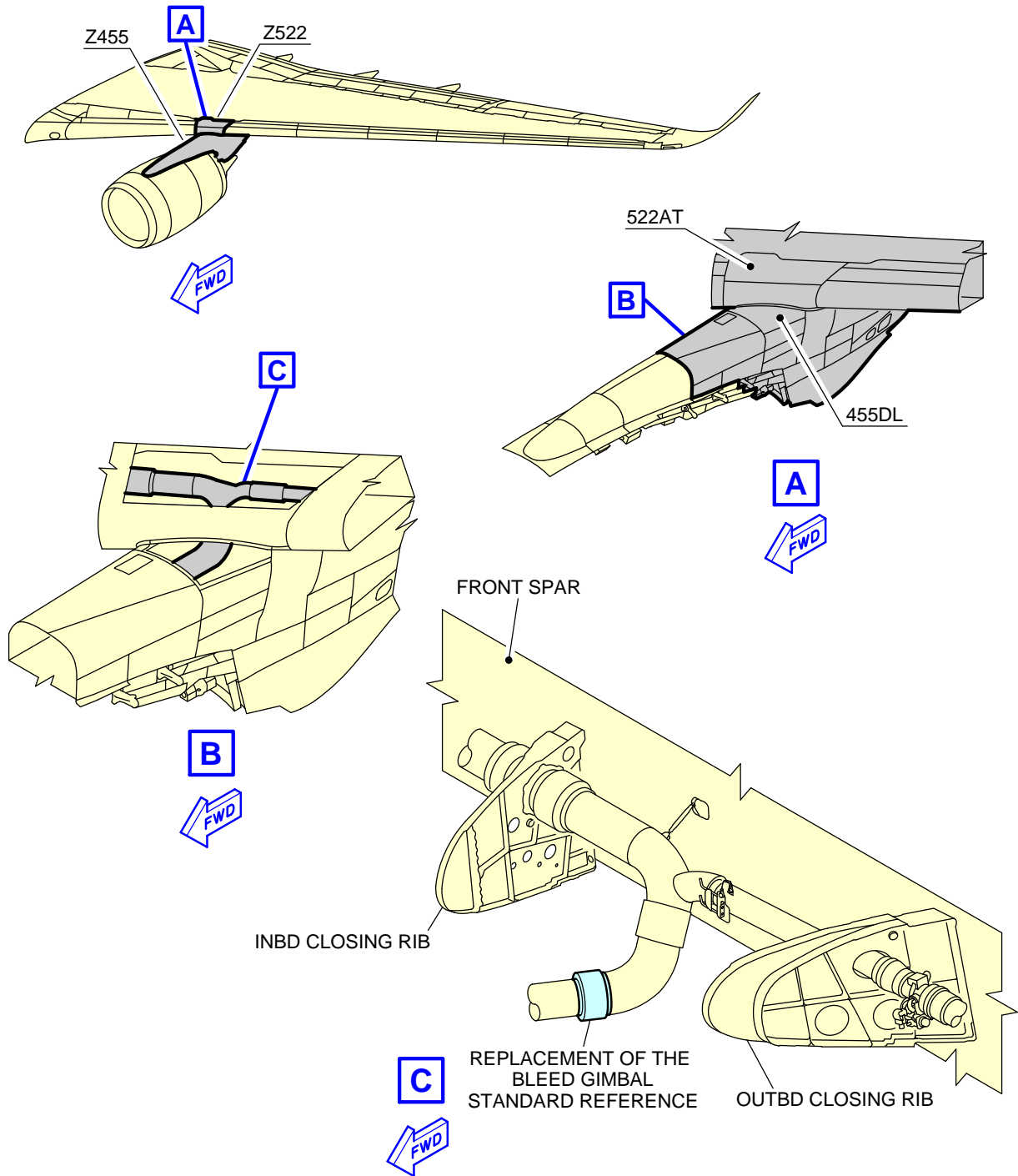

ICN-A350-A-36XXP023-A-FAPE3-05C0C-A-001-01

Figure ICN-A350-A-36XXP023-A-FAPE3-05C0C-A-001-01 SHEET 1/1

ATA SYSTEM: 36

TITLE: PNEUMATIC - DISTRIBUTION - INSTALL NEW BLEED GIMBAL STANDARD REFERENCE - LHS

1. PLANNING INFORMATION

A. APPLICABILITY

NOTE: This modification is applicable by Service Bulletin only.

(1) Models

ON A/C 0088, 0102, 0110, 0118, 0125, 0141, 0161, 0169, 0188, 0206, 0215, 0225, 0229, 0233, 0241, 0252, 0258, 0262, 0266, 0274, 0286, 0290, 0296, 0298, 0306, 0315, 0319, 0326, 0330, 0332, 0336, 0340, 0342

350-1041

ON A/C 0021-0058, 0060-0064, 0066-0070, 0072-0087, 0089-0101, 0103-0107, 0109, 0111-0117, 0119-0124, 0126-0130, 0132-0138, 0140, 0142-0151, 0153-0155, 0157-0160, 0162-0165, 0167, 0168, 0170, 0172-0187, 0189-0193, 0195-0205, 0207-0214, 0216-0221, 0223, 0224, 0226-0228, 0230-0232, 0234-0240, 0243-0251, 0254-0257, 0259-0261, 0263-0265, 0267-0273, 0276-0285, 0287, 0289, 0291-0295, 0297, 0299-0303, 0305, 0307-0314, 0316, 0318, 0320-0325, 0327-0329, 0331, 0333-0335, 0337-0339, 0341, 0343, 0347, 0351

350-941

CONF ALL

(2) Applicability by MSN

0021-0058 0060-0064 0066-0070 0072-0107 0109-0130 0132-0138 0140-0151 0153-0155 0157-0165 0167-0170 0172-0193 0195-0221 0223-0241 0243-0252 0254-0274 0276-0287 0289-0303 0305-0316 0318-0343 0347 0351

(3) MSN by configuration

MSN	CONFIGURATION
0021 0022 0023 0024 0025 0026 0027 0028 0029 0030 0031	001
0032 0033 0034 0035 0036 0037 0038 0039 0040 0041 0042	
0043 0044 0045 0046 0047 0048 0049 0050 0051 0052 0053	
0054 0055 0056 0057 0058 0060 0061 0062 0063 0064 0066	
0067 0068 0069 0070 0072 0073 0074 0075 0076 0077 0078	
0079 0080 0081 0082 0083 0084 0085 0086 0087 0088 0089	
0090 0091 0092 0093 0094 0095 0096 0097 0098 0099 0100	
0101 0102 0103 0104 0105 0106 0107 0109 0110 0111 0112	
0113 0114 0115 0116 0117 0118 0119 0120 0121 0122 0123	
0124 0125 0126 0127 0128 0129 0130 0132 0133 0134 0135	
0136 0137 0138 0140 0141 0142 0143 0144 0145 0146 0147	
0148 0149 0150 0151 0153 0154 0155 0157 0158 0159 0160	
0161 0162 0163 0164 0165 0167 0168 0169 0170 0172 0173	
0174 0175 0176 0177 0178 0179 0180 0181 0182 0183 0184	
0185 0186 0187 0188 0189 0190 0191 0192 0193 0195 0196	
0197 0198 0199 0200 0201 0202 0203 0204 0205 0206 0207	
0208 0209 0210 0211 0212 0213 0214 0215 0216 0217 0218	
0219 0220 0221 0223 0224 0225 0226 0227 0228 0229 0230	
0231 0232 0233 0234 0235 0236 0237 0238 0239 0240 0241	
0243 0244 0245 0246 0247 0248 0249 0250 0251 0252 0254	
0255 0256 0257 0258 0259 0260 0261 0262 0263 0264 0265	
0266 0267 0268 0269 0270 0271 0272 0273 0274 0276 0277	
0278 0279 0280 0281 0282 0283 0284 0285 0286 0287 0289	

MSN	CONFIGURATION
0290 0291 0292 0293 0294 0295 0296 0297 0298 0299 0300 0301 0302 0303 0305 0306 0307 0308 0309 0310 0311 0312 0313 0314 0315 0316 0318 0319 0320 0321 0322 0323 0324 0325 0326 0327 0328 0329 0330 0331 0332 0333 0334 0335 0336 0337 0338 0339 0340 0341 0342 0343 0347 0351	

(4) Configuration definition

Configuration 001

CONF 001 is applicable for all the aircraft affected by this Service Bulletin as a standard configuration.

CONF 001 retrofits following modifications: 114810L91112.

B. CONCURRENT REQUIREMENTS

None

C. REASON

(1) History

This Service Bulletin is issued to answer to quality assurance department has identified that a problem with internal interference of adjacent parts:

- Irregular welding of gimbal ring bush (raised and bumpy weld profile)
- Internal interference between bellows and gimbal rings (resistance between 7° and 8.5°)
- Damage to the inside diameter of the bellows assy membrane 8.5° gimbal (dent of outside of bellows).

(2) Objective/Action

This Service Bulletin consists in replacing a bleed gimbal Standard (STD) on Left Hand (LH) wing.

(3) Advantages

Accomplishment of this Service Bulletin cancels the requirements of Ref. SB A350-36-P029.

The accomplishment of this Service Bulletin will improve the gimbal quality.

(4) Operational/Maintenance Consequences

None

D. DESCRIPTION

To accomplish this Service Bulletin it is necessary to:

(1) Modification

(a) Task set A350-A-36-XX-P023-01000-93AA-A Modification

- 1 Remove the Bleed Gimbal Standard Reference for the LH Wing to Pylon Interface
- 2 Install the Bleed Gimbal Standard Reference for the LH Wing to Pylon Interface

E. COMPLIANCE

(1) Classification

RECOMMENDED: Service Bulletin recommended to be accomplished to prevent significant operational disruptions.

(2) Accomplishment Timescale

Accomplishment of this Service Bulletin is recommended before reaching 5600 Flight Cycles (FC).

This Service Bulletin has been classified Recommended. It is expected that an Airworthiness Directive (AD) published by the European Aviation Safety Agency (EASA) will be issued to change this classification to Mandatory. It is anticipated that the AD will confirm the thresholds given but reference should be made to the AD for confirmation of the mandated accomplishment timescale.

F. APPROVAL

The technical content of this document is approved under the authority of Design Organisation Approval No. EASA.21J.031.

If an aircraft listed in the applicability has a modification or repair embodied that is not of AIRBUS origin, and which affects the content of this Service Bulletin, the operator is responsible for obtaining approval by its airworthiness authority for any adaptation necessary before incorporation of the Service Bulletin.

G. MANPOWER

The manpower estimates given in this Service Bulletin are based on the direct labor cost to do the work. These estimates assume that the work will be done by experienced personnel, and may need to be revised upwards to suit operator's circumstances. The estimates do not include the time to prepare, plan or inspect the work. Manufacture and procurement of parts and tools, drying times for paints, sealants, etc., and general administration work are also not included.

(1) Modification

(a) Task set A350-A-36-XX-P023-01000-93AA-A Modification

PREPARATION		
Job Set-up	2.00 h	
PROCEDURE		
Remove the Bleed Gimbal Standard Reference for the LH Wing to Pylon Interface	1.00 h	
Install the Bleed Gimbal Standard Reference for the LH Wing to Pylon Interface	1.50 h	
PREPARATION FOR TEST		
Preparation for Test	0.25 h	
TEST		
Leak Test	1.00 h	
CLOSE-UP		
Close-up	2.00 h	
TOTAL MAN-HOURS	7.75 h	
ELAPSED TIME (HOURS)	5.25 h	

H. WEIGHT AND BALANCE

Not changed

I. ELECTRICAL LOAD DATA

Not changed

J. REFERENCES

(1) Modification

(a) Task set A350-A-36-XX-P023-01000-93AA-A Modification

AIRCRAFT STRUCTURAL REPAIR (ASR)	
A350-A-51-77-11-00ZZZ-660Z-A	
ELECTRICAL STANDARD PRACTICES (ESP)	
A350-A-20-55-XX-01ZZZ-042Z-A	
INTRODUCTION (INTRO)	
A350-A-00-61-04-11ZZZ-018Z-D	
MAINTENANCE PROCEDURE (MP)	
A350-A-20-51-50-04ZZZ-25BZ-A	A350-A-24-41-XX-00ZZZ-170Z-A
A350-A-36-11-48-00ZZZ-320Z-A	
A350-A-36-11-48-07ZZZ-520Z-A	
A350-A-36-11-48-08ZZZ-720Z-A	
SERVICE BULLETIN (SB)	
A350-36-P029	
SYSTEM DESCRIPTION (SD)	
A350-A-06-3X-XX-01ZZZ-04CZ-A	A350-A-06-4X-XX-01ZZZ-04CZ-A
TECHNICAL FOLLOW UP (TFU)	
36.11.00107	

STANDARDS MANUAL (SM)

CONSUMABLE MATERIAL LIST (CML)

K. PUBLICATION AFFECTED

MAINTENANCE ILLUSTRATED PART DATA (MIPD)

MAINTENANCE PROCEDURE (MP)

L. INDUSTRY SUPPORT INFORMATION

For aircraft on which this SB is accomplished further to finding as per inspection Ref. SB A350-36-P029:

- AIRBUS will share the costs of accomplishment of this Service Bulletin by providing the kits at no charge for orders placed within 24 months after the initial issue date of the Service Bulletin.
- AIRBUS will credit the man hours indicated in this Service Bulletin at the agreed in-house warranty labor rate for the accomplishment of this Service Bulletin within 24 months after the initial issue date of the inspection Service Bulletin. Claims shall be received no later than 90 days after the last aircraft of your fleet completed within 24 months after the initial issue date of the inspection Service Bulletin.

- This Service Bulletin is the subject of an AIRBUS monitored retrofit campaign.
- For the organization of this retrofit, you are kindly requested to contact AIRBUS retrofit management department: monitored.retrofit@airbus.com.

For aircraft on which this SB is not accomplished further to finding as per inspection Ref. SB A350-36-P029:

- AIRBUS will not provide industry support for accomplishment of this Service Bulletin.
- This Service Bulletin is the subject of an AIRBUS monitored retrofit campaign.
- For the organization of this retrofit, you are kindly requested to contact AIRBUS retrofit management department: monitored.retrofit@airbus.com.

2. MATERIAL INFORMATION

A. MATERIAL APPLICABILITY

Material for task set A350-A-36-XX-P023-01000-93AA-A Modification

MATERIAL	QTY	SEE NOTES
Referenced tools	See SB	
Consumables	See SB	
Referenced consumables	See SB	
Part kit 36P023C01R01	1	
Interchangeable parts	See SB	
Spare parts	See SB	

B. TOOLING

Referenced tools for task set A350-A-36-XX-P023-01000-93AA-A Modification

To accomplish this Service Bulletin it is necessary to use the tools listed in the subsequent referenced tasks:

Ref. MP A350-A-36-11-48-07ZZZ-520Z-A

Ref. MP A350-A-36-11-48-08ZZZ-720Z-A

Ref. MP A350-A-36-11-48-00ZZZ-320Z-A

C. CONSUMABLES

Consumables for task set A350-A-36-XX-P023-01000-93AA-A Modification

ITEM	REFERENCE CML	DESCRIPTION	DRAWING	SEE NOTES
	08BAA9	Non Aqueous Cleaner - General		
	14SBA1	Textile - Lint free Cotton		

Referenced consumables for task set A350-A-36-XX-P023-01000-93AA-A Modification

To accomplish this Service Bulletin it is necessary to use the consumable materials listed in the subsequent referenced tasks:

Ref. MP A350-A-20-51-50-04ZZZ-25BZ-A

Ref. MP A350-A-36-11-48-00ZZZ-320Z-A

D. LIST OF NEW PARTS

Part kit 36P023C01R01

Cost	4300.00 USD
Availability	200 d (calendar days from receipt of order)
NOTE(S)	
<p>The sales terms (costs and availability) are estimated in relation to economic conditions. The latest valid price and lead time for ordering purposes shall be obtained through the AIRBUS Spares portal or through a request for quotation to airbus.kit@airbus.com.</p> <p>The availability given above is the standard lead time from the date of your purchase order. If items are required before this time, please include a retrofit planning schedule with your order so that we can try to comply with your requirements.</p>	

Procurement address	D4296	AIRBUS Material, Logistics and Suppliers ATP II B, Hein-Sass-Weg 24 21129 HAMBURG GERMANY Phone: +49 40 743 51775 E-mail: airbus.kit@airbus.com Internet: http://spares.airbus.com
---------------------	-------	---------------------------------------------------------------------------------------------------------------------------------------------------------------------------------------------------------

NOTE(S)
Customers with aircraft shown in the applicability of this Service Bulletin should send a purchase order to AIRBUS at the address given above and quote the number of this Service Bulletin.

ITEM	PART No.	QTY (UM)	KEYWORD	DRAWING	SEE NOTES
5	ABS0736E9696R	1	JOINT		
6	ABS1407-02N96	2	SEAL		

NOTE(S)
Refer to the AIRBUS Ref. SM if you find part numbers of hardware components which you cannot identify. The SM will give you the correct part number to part number relationship.

E. LIST OF EXISTING PARTS

Interchangeable parts for task set A350-A-36-XX-P023-01000-93AA-A Modification

DESCRIPTION	OLD PART No.	NEW PART No.	INT	SEE NOTES
JOINT-GIMBAL	ABS0736E9696S	ABS0736E9696R	01	(1) (2)

NOTE(S)
Refer to the AIRBUS Ref. SM if you find part numbers of hardware components which you cannot identify. The SM will give you the correct part number to part number relationship.

For definitions of interchangeability codes in column INT. refer to ATA (CSDD Chapter 2).

(1): The interchangeability possibilities are for new or modified parts introduced by the accomplishment of this Service Bulletin.

(2): Mixability not applicable.

Spare parts for task set A350-A-36-XX-P023-01000-93AA-A Modification

DESCRIPTION	OLD PART No.	SEE NOTES
JOINT-GIMBAL	ABS0736E9696S	(1)

NOTE(S)
Refer to the AIRBUS Ref. SM if you find part numbers of hardware components which you cannot identify. The SM will give you the correct part number to part number relationship.

(1): The parts listed here must not be installed anymore on aircraft which have accomplished this Service Bulletin or which have the equivalent production modification embodied.

3. **ACCOMPLISHMENT INSTRUCTIONS**

Task set A350-A-36-XX-P023-01000-93AA-A
Modification

WARNING: MAKE SURE THAT YOU OBEY ALL THE WARNINGS AND ALL THE CAUTIONS INCLUDED IN THE REFERENCED PROCEDURES.

CAUTION: ALWAYS OBEY THE PRECAUTIONS THAT FOLLOW TO KEEP ELECTRICAL WIRING IN A SATISFACTORY CONDITION (ELECTRICALLY AND MECHANICALLY SERVICEABLE). WHEN YOU DO MAINTENANCE WORK, REPAIRS OR MODIFICATIONS, ALWAYS KEEP ELECTRICAL WIRING, COMPONENTS AND THE WORK AREA AS CLEAN AS POSSIBLE. TO DO THIS:

- **PUT PROTECTION, SUCH AS PLASTIC SHEETING, CLOTHS, ETC., AS NECESSARY ON WIRING AND COMPONENTS.**
- **REGULARLY REMOVE ALL SHAVINGS, UNWANTED MATERIAL AND OTHER CONTAMINATION.**

THESE PRECAUTIONS WILL DECREASE THE RISK OF CONTAMINATION AND DAMAGE TO THE ELECTRICAL WIRING INSTALLATION. IF THERE IS CONTAMINATION, REFER TO Ref. ESP A350-A-20-55-XX-01ZZZ-04ZZ-A.

NOTE: The accomplishment instructions of this Service Bulletin include procedures given in other documents or in other sections of the Service Bulletin. When the words "refer to" are used and the operator has a procedure accepted by the local authority he belongs to, the accepted alternative procedure can be used. When the words "in accordance with" are used then the given procedure must be followed.

NOTE: The access and close-up instructions, not comprising return to service tests, in this Service Bulletin do not constitute or affect the technical intent of the Service Bulletin. Operators can therefore, as deemed necessary, omit or add access and/or close-up steps to add flexibility to their maintenance operations as long as the technical intent of the Service Bulletin is met within the set parameters.

NOTE: Manual titles given in the accomplishment instructions are referred to by acronyms. Refer to paragraph 1.J., References, for the definition of acronyms.

NOTE: This Service Bulletin is classified mandatory or expected to be classified mandatory by an Airworthiness Directive (AD). The paragraphs 3.C. and 3.E. in these accomplishment instructions are Required for Compliance (RC) and must be done to comply with the AD. To allow more flexibility, the rule "refer to" and "in accordance with" will apply to these paragraphs 3.C. and 3.E. Other paragraphs are recommended and may be deviated from, done as part of other actions or done with accepted methods different from those given in the Service Bulletin, as long as the RC paragraphs can be done and the aircraft can be put back into a serviceable condition.

NOTE: This Service Bulletin contains the instructions for the on-aircraft maintenance necessary to ensure the continued airworthiness of the aircraft. For any deviations to the instructions, including RC paragraph contained herein, contact AIRBUS for further instructions and approval.

NOTE: Discarded parts must be managed at the operator's discretion.

A. TASK SET ASSOCIATED INFORMATION

Task Manpower

TOTAL MAN-HOURS	7.75 h
ELAPSED TIME (HOURS)	5.25 h

B. PREPARATION

(1) Task A350-A-36-XX-P023-01001-540A-A - Job Set-up

Job Set-Up Information

Manpower/Resources/Skills

Man-hours	2.00 h
Minimum Number of person	2
Elapsed Time	1.00 h

Referenced Information

Manuals/Drawings	References/Sheets
INTRO	A350-A-00-61-04-11ZZZ-018Z-D
MP	A350-A-24-41-XX-00ZZZ-170Z-A A350-A-36-11-48-07ZZZ-520Z-A

Procedure

NOTE: For the basic Aircraft configuration, refer to Ref. INTRO A350-A-00-61-04-11ZZZ-018Z-D "Maintenance Procedure - Introduction".

- (a) Make sure that the aircraft is electrically grounded, refer to Ref. MP A350-A-24-41-XX-00ZZZ-170Z-A.
- (b) Do the job set-up procedure as specified in the removal of the wing bleed air ducts between the inboard closing rib and the outboard closing rib, refer to Ref. MP A350-A-36-11-48-07ZZZ-520Z-A.

NOTE: It is necessary to remove only Panel 522AT and Panel 455DL.

C. PROCEDURE

(1) Task A350-A-36-XX-P023-01001-520A-A - Remove the Bleed Gimbal Standard Reference for the LH Wing to Pylon Interface

Job Set-Up Information

Working Area

Impacted Zone	Access / Work Location	
455	Access	Panel 455DL
522	Access	Panel 522AT

Manpower/Resources/Skills

Man-hours	1.00 h
Minimum Number of person	1
Elapsed Time	1.00 h

Material necessary to do the job

Consumables				
ITEM	REFERENCE CML	DESCRIPTION	DRAWING	SEE NOTES
	08BAA9	Non Aqueous Cleaner - General		
	14SBA1	Textile - Lint free Cotton		

Referenced Information

Manuals/Drawings	References/Sheets
ASR	A350-A-51-77-11-00ZZZ-660Z-A
SD	A350-A-06-3X-XX-01ZZZ-04CZ-A A350-A-06-4X-XX-01ZZZ-04CZ-A
CML	CONSUMABLE MATERIAL LIST (CML)

Procedure

(a) Standard practices given in this procedure:

- 1 For identification of zones, refer to Ref. SD A350-A-06-3X-XX-01ZZZ-04CZ-A.
- 2 For the identification of access panels, refer to Ref. SD A350-A-06-4X-XX-01ZZZ-04CZ-A.
- 3 Tag all the parts you must remove and retain to make the subsequent installation easier.
- 4 Put all the retained hardware in identified plastic bags and attach the bags to the related unit.
- 5 For the specification of Material application codes given in this Service Bulletin, refer to the Ref. CML.
- 6 Do the cleaning process in accordance with Ref. ASR A350-A-51-77-11-00ZZZ-660Z-A.

(b) Remove the bleed gimbal:

Refer to Ref. Fig. Removal of the Bleed Gimbal Standard Reference for the LH Wing to Pylon Interface

- 1 Disconnect the hose assembly, Item (1), to remove the muff, Item (2).
- 2 Release the velcro tapes of the muffs, Item (2), to open this.
- 3 Remove and retain the muff, Item (2):

1	MUFF INSULATION	Item (2)	Retain
---	-----------------	----------	--------
- 4 Remove the self locking nut, Item (3), then open and remove the clamp, Item (4):

2	SELF LOCKING NUT	Item (3)	Retain
2	CLAMP	Item (4)	Retain
- 5 Remove the gimbal, Item (5):

1	JOINT-GIMBAL	ABS0736E9696S	Item (5)	Discard
---	--------------	---------------	----------	---------
- 6 Remove the applicable E-seal, Item (6):

2	E-SEAL	Item (6)	Discard
---	--------	----------	---------
- 7 Put a blanking plug in each disconnected duct end.
- 8 Clean the work area and the retained parts with:

Non Aqueous Cleaner - 08BAA9
General
and
Textile - Lint free Cotton 14SBA1

CONF ALL

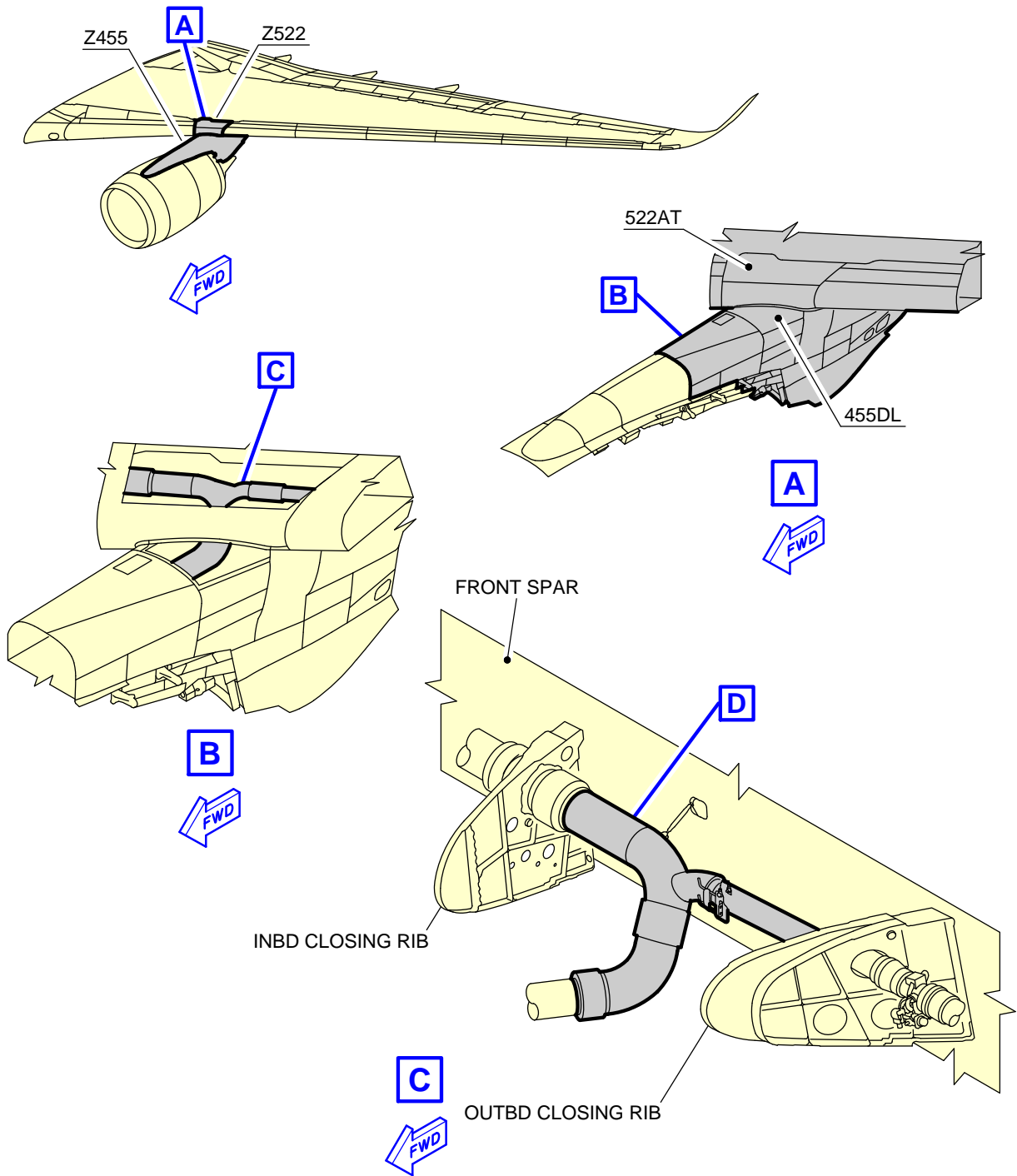

ICN-A350-A-36XXP023-A-FAPE3-05C0D-A-001-01

Figure ICN-A350-A-36XXP023-A-FAPE3-05C0D-A-001-01 SHEET 1/2

CONF ALL

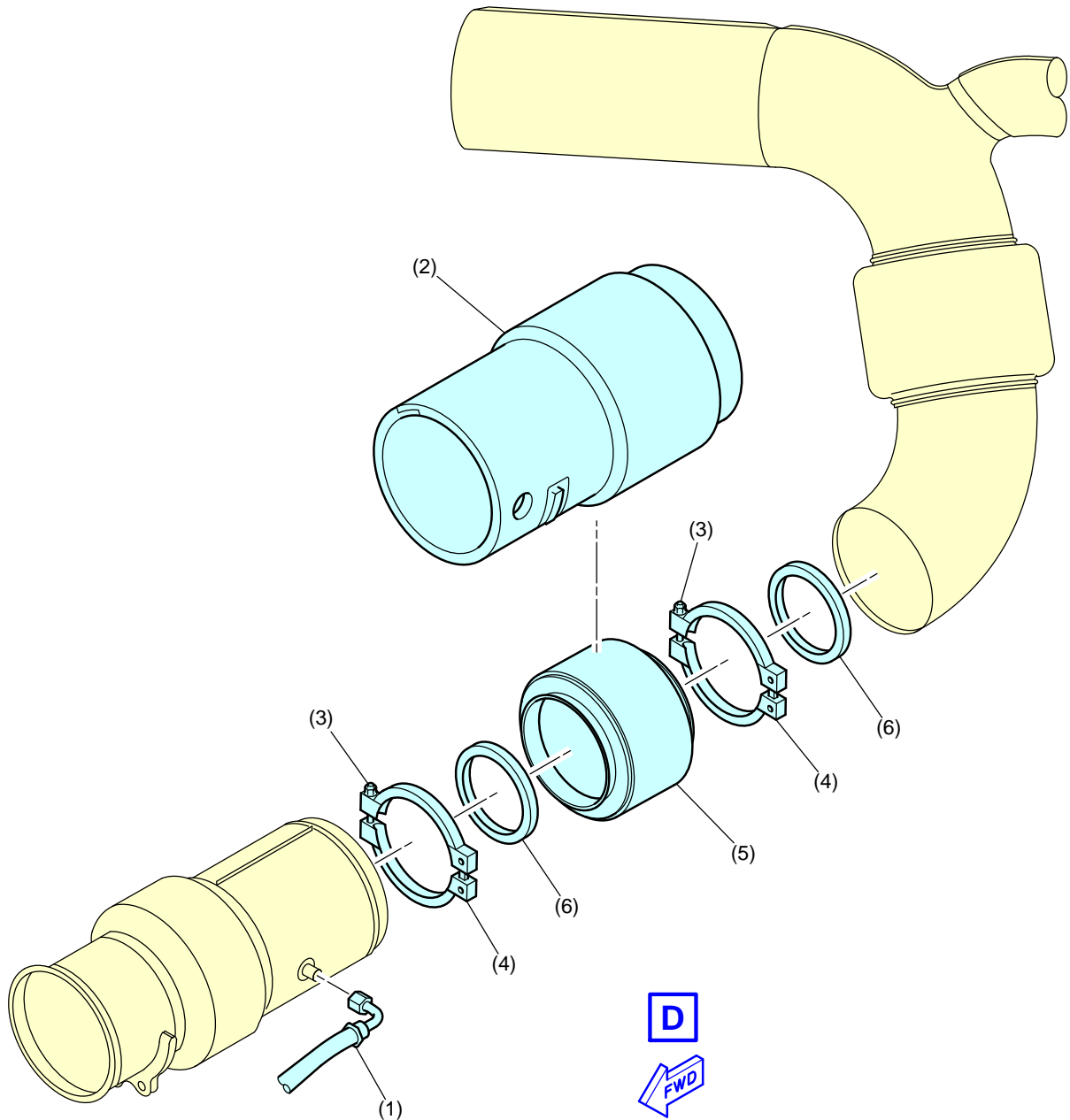

ICN-A350-A-36XXP023-A-FAPE3-05C0Q-A-001-01

Figure ICN-A350-A-36XXP023-A-FAPE3-05C0Q-A-001-01 SHEET 2/2

REV 00 Apr 09/20

Removal of the Bleed Gimbal Standard
Reference for the LH Wing to Pylon Interface

A350-36-P023
Page 16

(2) Task A350-A-36-XX-P023-01001-720A-A - Install the Bleed Gimbal Standard Reference for the LH Wing to Pylon Interface

Job Set-Up Information

Working Area

Impacted Zone	Access / Work Location	
455	Access	Panel 455DL
522	Access	Panel 522AT

Manpower/Resources/Skills

Man-hours	1.50 h
Minimum Number of person	1
Elapsed Time	1.50 h

Material necessary to do the job

Part kit 36P023C01R01					
ITEM	PART No.	QTY (UM)	KEYWORD	DRAWING	SEE NOTES
5	ABS0736E9696R	1	JOINT		
6	ABS1407-02N96	2	SEAL		

Referenced Information

Manuals/Drawings	References/Sheets
MP	A350-A-20-51-50-04ZZZ-25BZ-A
SD	A350-A-06-3X-XX-01ZZZ-04CZ-A A350-A-06-4X-XX-01ZZZ-04CZ-A

Procedure

- (a) Standard practices given in this procedure:
- 1 For identification of zones, refer to Ref. SD A350-A-06-3X-XX-01ZZZ-04CZ-A.
 - 2 For the identification of access panels, refer to Ref. SD A350-A-06-4X-XX-01ZZZ-04CZ-A.
- (b) Install the new bleed gimbal:
Refer to Ref. Fig. Installation of the Bleed Gimbal Standard Reference for the LH Wing to Pylon Interface
- 1 Remove the blanking plug from each disconnected duct end.
 - 2 Put the gimbal, Item 5, in position between the pipe junction, Item (7), and the pipe junction, Item (8):
- | | | | | |
|---|--------------|------------------------------------------------------------------------------------------------------------------|----------|----------|
| 1 | JOINT-GIMBAL | ABS0736E9696R | Item 5 | |
| | <u>3</u> | Install the applicable E-seal, Item 6, at the end of the pipe junction, Item (7): | | |
| 1 | E-SEAL | ABS1407-02N96 | Item 6 | |
| | <u>4</u> | Engage the gimbal, Item 5, with the pipe junction, Item (7), and put the clamp, Item (4), on the E-seal, Item 6: | | |
| 1 | JOINT-GIMBAL | ABS0736E9696R | Item 5 | |
| 1 | CLAMP | | Item (4) | Retained |

NOTE: Be careful to make sure that the E-seal, Item 6, at end of the pipe junction, Item (7), are correctly assembled.

NOTE: Be careful to make sure that there is a clearance between the E-seal, Item 6, of the clamp, Item (4), and the sensing elements.

5 Install the applicable E-seal, Item 6, at the end of the pipe junction, Item (8):

1	E-SEAL	ABS1407-02N96	Item 6
---	--------	---------------	--------

6 Engage the gimbal, Item 5, with the pipe junction, Item (8), and put the clamp, Item (4), on the E-seal, Item 6:

1	JOINT-GIMBAL	ABS0736E9696R	Item 5
---	--------------	---------------	--------

1	CLAMP		Item (4)	Retained
---	-------	--	----------	----------

NOTE: Be careful to make sure that the E-seal, Item 6, at end of the pipe junction, Item (8), are correctly assembled.

NOTE: Be careful to make sure that there is a clearance between the E-seal, Item 6, of the clamp, Item (4), and the sensing elements.

7 Install the self locking nuts, Item (3), on the clamps, Item (4):

2	SELF LOCKING NUTS		Item (3)	Retained
---	-------------------	--	----------	----------

8 Torque the self locking nuts, Item (3), to between 3.39 and 3.95 Nm (30.004 and 34.960 lbf.in.).

9 Put mark on the self locking nuts, Item (3), refer to Ref. MP A350-A-20-51-50-04ZZZ-25BZ-A.

10 Install the retained muff, Item (2):

1	MUFF INSULATION		Item (2)	Retained
---	-----------------	--	----------	----------

NOTE: The correct position of the muffler assy and muff insulation for installation is specified by the shape of the muff.

NOTE: Be careful to make sure to respect the minimum distance from the elements of structure at 20 mm (0.787 in.).

NOTE: Be careful to make sure to respect the minimum distance from environment at 5 mm (0.197 in.).

11 Connect the hose assembly, Item (1).

12 Torque the hose assembly connection, Item (1), to between 24.30 and 31.60 Nm (215.073 and 279.684 lbf.in.).

13 Put mark on the hose assembly connection, Item (1), refer to Ref. MP A350-A-20-51-50-04ZZZ-25BZ-A.

CONF ALL

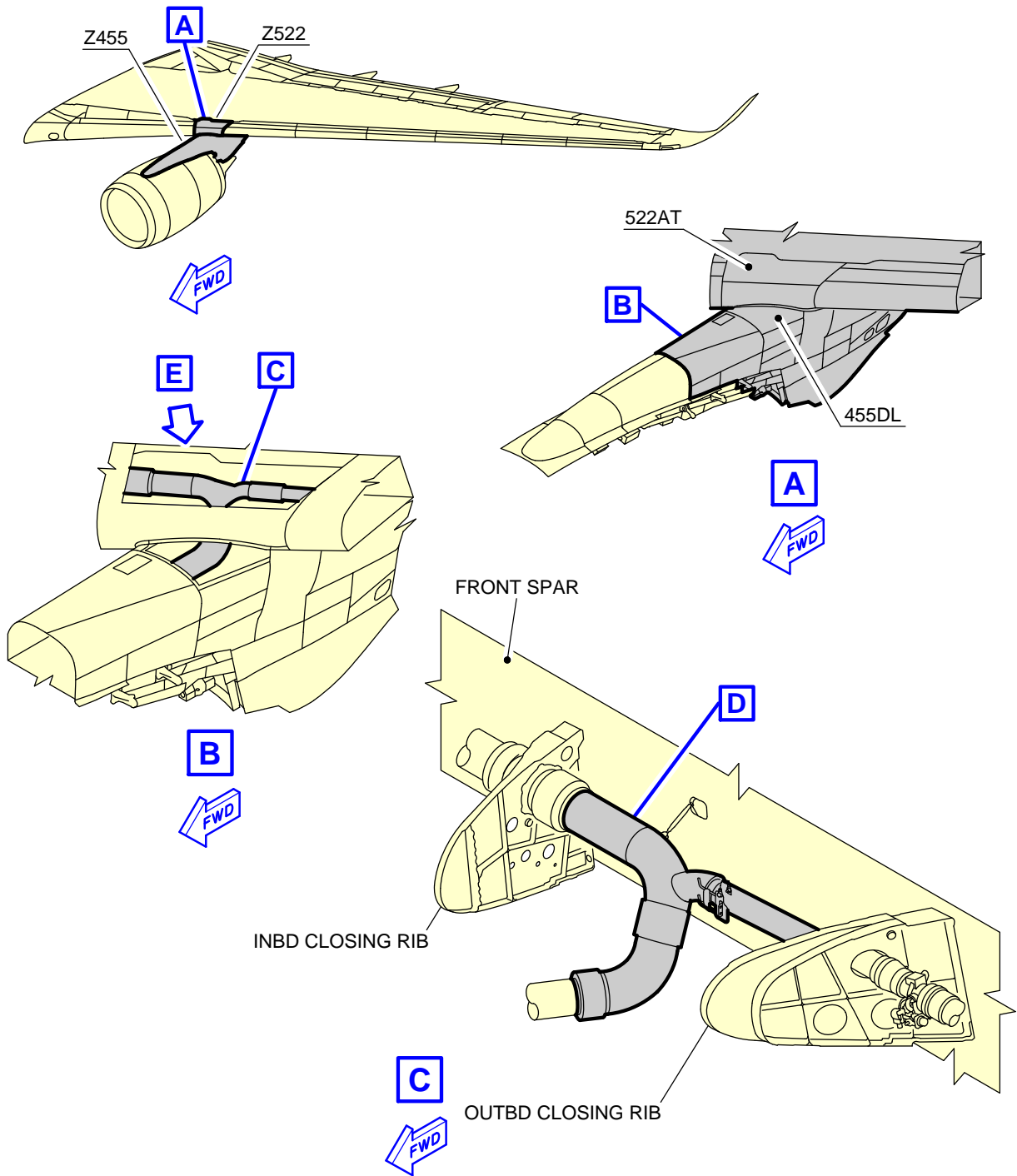

ICN-A350-A-36XXP023-A-FAPE3-05BQ5-A-001-01

Figure ICN-A350-A-36XXP023-A-FAPE3-05BQ5-A-001-01 SHEET 1/3

CONF ALL

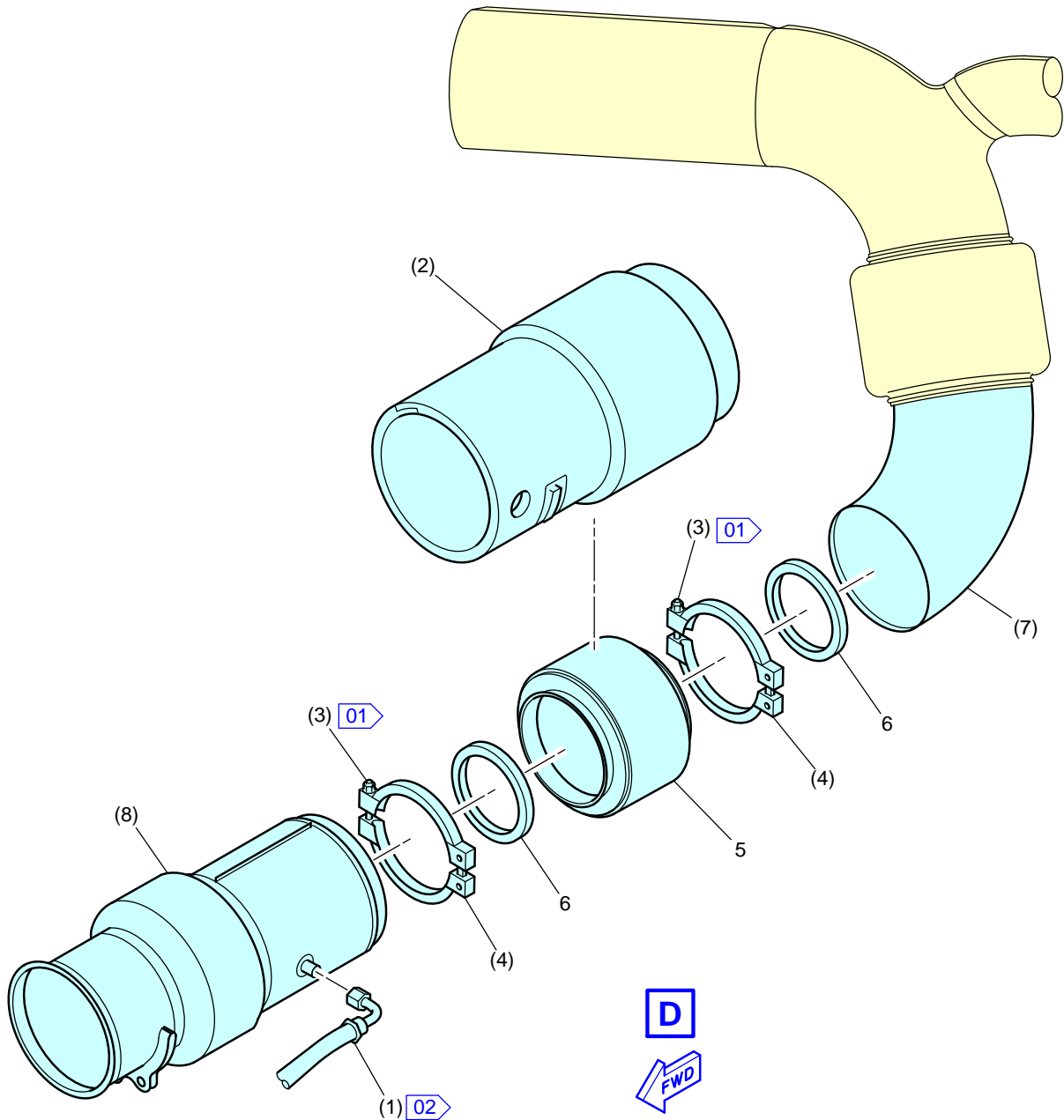

NOTE:

- 01** TORQUE THE SELF LOCKING NUTS, ITEM (3), TO BETWEEN 3.39 AND 3.95 Nm (30.004 AND 34.960 lbf.in).
- 02** TORQUE THE HOSE ASSEMBLY CONNECTION, ITEM (1), TO BETWEEN 24.30 AND 31.60 Nm (215.073 AND 279.684 lbf.in).

ICN-A350-A-36XXP023-A-FAPE3-05BQ6-A-002-01

Figure ICN-A350-A-36XXP023-A-FAPE3-05BQ6-A-002-01 SHEET 2/3

CONF ALL

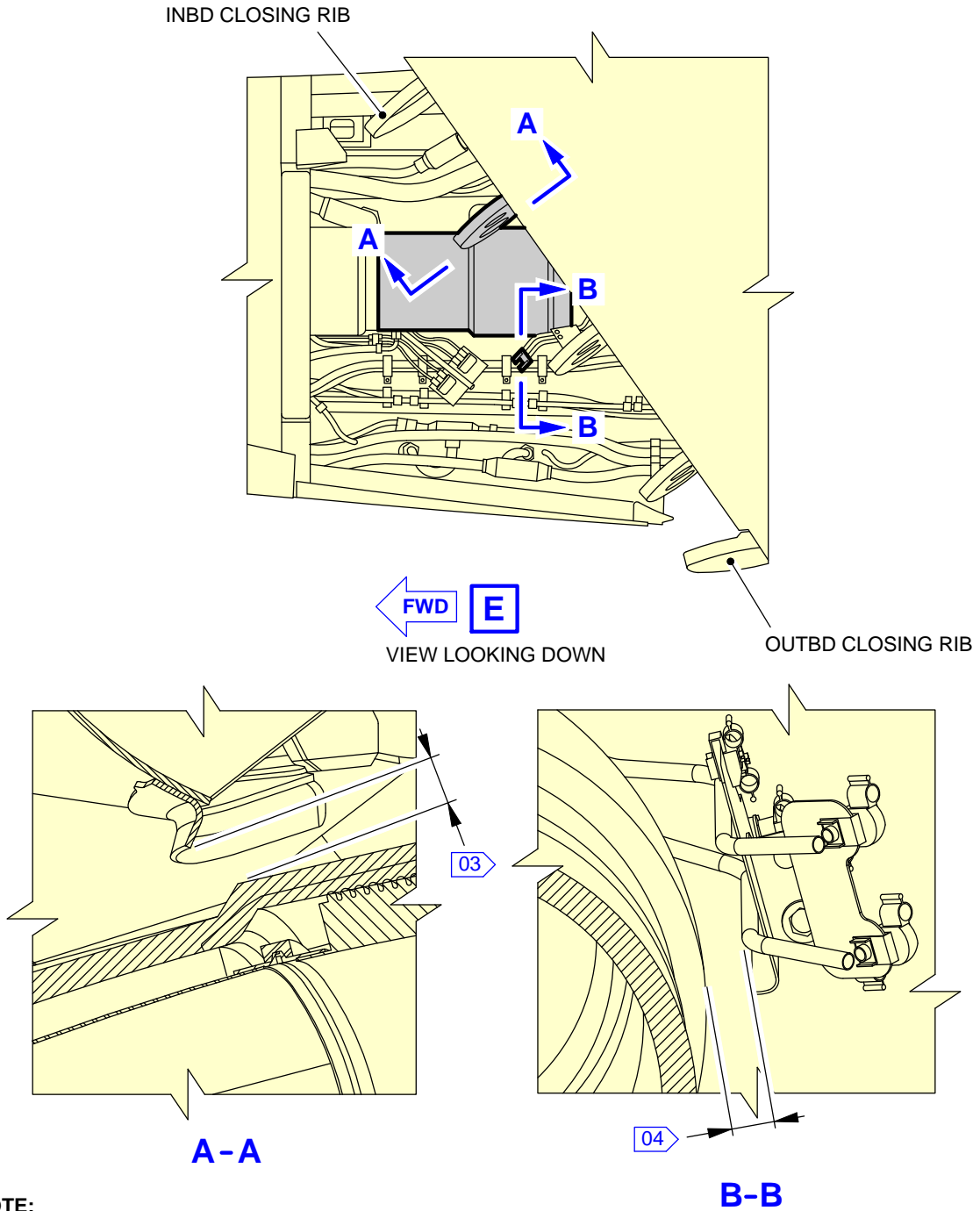

NOTE:

- 03 MINIMUM DISTANCE FROM THE ELEMENTS: 20 mm (0.787 in).
- 04 MINIMUM DISTANCE FROM THE WING ENVIRONMENT: 5 mm (0.197 in).

ICN-A350-A-36XXP023-A-FAPE3-05BQ7-A-001-01

D. PREPARATION FOR TEST

(1) Task A350-A-36-XX-P023-01001-92AA-A - Preparation for Test

Job Set-Up Information

Manpower/Resources/Skills

Man-hours	0.25 h
Minimum Number of person	1
Elapsed Time	0.25 h

Referenced Information

Manuals/Drawings	References/Sheets
MP	A350-A-36-11-48-08ZZZ-720Z-A

Procedure

- (a) Remove the safety clip(s) and/or tag(s) and close/unlock the circuit breaker(s), refer to Ref. MP A350-A-36-11-48-08ZZZ-720Z-A.

E. TEST

(1) Task A350-A-36-XX-P023-01001-364A-A - Leak Test

Job Set-Up Information

Manpower/Resources/Skills

Man-hours	1.00 h
Minimum Number of person	2
Elapsed Time	0.50 h

Referenced Information

Manuals/Drawings	References/Sheets
MP	A350-A-36-11-48-00ZZZ-320Z-A

Procedure

- (a) Do the leak test of the bleed air ducting in the wing area between bleed air precooler exchangers, wing anti-ice valves and wing/fuselage connection, refer to Ref. MP A350-A-36-11-48-00ZZZ-320Z-A.

F. CLOSE-UP

(1) Task A350-A-36-XX-P023-01001-740A-A - Close-up

Job Set-Up Information

Manpower/Resources/Skills

Man-hours	2.00 h
Minimum Number of person	2
Elapsed Time	1.00 h

Referenced Information

Manuals/Drawings	References/Sheets
MP	A350-A-36-11-48-08ZZZ-720Z-A

Procedure

- (a) Make sure that the work areas are clean and clear of tools and other items of equipment.
- (b) Do the close-up procedure as specified in the installation of the wing bleed air ducts between the inboard closing rib and the outboard closing rib, refer to Ref. MP A350-A-36-11-48-08ZZZ-720Z-A.

NOTE: It is necessary to install only Panel 522AT and Panel 455DL.

- (c) Put the aircraft back to its initial configuration.

G. ADMINISTRATIVE

(1) Task A350-A-36-XX-P023-01001-90AA-A - Administrative

Procedure

Confirm in the applicable aircraft records that you have completed all the work defined in this Service Bulletin task set as required.

APPENDIX

A. REPORTING SHEET

TITLE:	PNEUMATIC - DISTRIBUTION - INSTALL NEW BLEED GIMBAL STANDARD REFERENCE - LHS
MODIFICATION No.:	114810L91112

(1) **SB Reporting status**

This Service Bulletin will only be incorporated into affected customized Maintenance and Flight Operations Products if it is duly reported to Airbus.

(2) **GENERAL information**

The SB Reporting policy is published in ISI 00.00.00135. This document provides information regarding: the SB Reporting means and benefits, the update of customized Maintenance Products and customized Flight Operations Products.

If this Service Bulletin has an operational impact, refer to paragraph "Flight Operations Products" for further information on the update of affected Flight Operations Products.

(3) **SB Reporting procedure**

Standard practice to report SB is to use the online reporting application on AirbusWorld.

Refer to ISI 00.00.00179:

- For complete information on reporting means to Airbus, Question 2 "What are the standard practices for SB Reporting?"
- If this SB requires previous or simultaneous accomplishment of other SBs, Question 3 "What about the reporting of prerequisite Service Bulletins?"

NOTE: ISI 00.00.00179 covers all the frequently asked questions about SB Reporting. It is revised on a regular basis.

B. QUALITY PERCEPTION FORM

Use this form to tell us what is your perception of the quality of this Service Bulletin.

The reported data that you provide us will be used to analyse areas of difficulties and to take corrective action to further improve the quality of our Service Bulletin.

We thank you for the time you have taken in completing this form.

Quality rating of this SB	4	3	2	1
Quality rating of the Accomplishment Instructions	4	3	2	1
Quality rating of the Illustrations	4	3	2	1
Is this SB easy to understand ?	Y / N			

NOTE: Please rate on a scale of 1 to 4, with 4 being the highest score

If you have difficulties in the accomplishment of this SB please quote below the area(s) and give a short description of the issue.

	Planning		Material		Instructions
X	Applicability	X	Tooling	X	Preparation
X	Reason	X	List of Materials Operator Supplied	X	Mod/Inspection
X	Manpower	X	Kit content	X	Test
X	References	X	Re-identification	X	Close-up
X	Publication			X	Illustrations
X	Industry Support				

Comments :

Operator :
Name/Title

Date :

Please return this form to :

AIRBUS
2, ROND POINT EMILE DEWOITINE
31700 BLAGNAC
FRANCE

Or via your Resident Customer Support Office.