



Drives and motors catalogue 2010

ABB Distributor:

Easycom Automation Co.

Tel:+86-20-38473560 Fax:+86-20-38473550

Add. Hubiao Sq,Tianhe,Guangzhou, China

Email: info@gzeasycom.com

<http://www.gzeasycom.com>

Power and productivity
for a better world™



Product Quickfinder

Select the drive product by the quick criteria below

Supply voltage	Motor power kW	IP rating	Drive family	Drive type
110-120V 1 ph 200-240V 1 ph 208-240V 3 ph 380-480V 3 ph 380-415V 3 ph 500V 3ph 690V 3ph	0.18 to 0.37 0.18 - 2.2	IP20	ABB component drive	ACS55
	0.37 - 2.2 0.37 - 2.2 0.37 - 4.0	IP20 NEMA 1	ABB component drive	ACS150
	0.37 - 2.2 0.37 - 11.0 0.37 - 22.0	IP20 NEMA 1 IP66/69k	ABB general machinery drive	ACS355
	0.75 - 110	IP20	ABB high performance machinery drive	ACSM1
	0.75 - 75 1.1 - 160 200 - 355	IP20, 54 IP20	ABB standard drive	ACS550
	0.37 - 11.0 0.37 - 22.0	IP20 NEMA 1	ABB standard drive for fans and pumps	ACS310
	1.1 - 160 200 - 400	IP20 IP00	ABB industrial drive for water and waste water	ACQ810
	0.55 - 55 1.1 - 160 1.5 - 200 5.5 - 160	IP20,21,55	ABB industrial drive - wall mounted units	ACS800 - 01/11/ 31
	45 - 200 90 - 1450 110 - 1850 90 - 1900	IP00, 21	ABB industrial drive - modules	ACS800 - 02/04/14. ACS850
	45 - 1450 55 - 1850 45 - 2800	IP21, 22, 42, 54, 54R	ABB industrial drive - cabinet drives	ACS800 - 07/17/37
	1.1 - 5600		Other ABB industrial drives variants	ACS800 - various
Medium voltage AC Low voltage DC HVAC and power quality	315 - 27MW 25A - 5.2kA -	various		

Select the motor product by the quick criteria below

Supply voltage	Motor power kW	IP rating	Motor family	Motor type
208-240V 3ph 380-480V 3ph 380-415V 3ph 500V 3ph 660-690V 3ph	0.25 - 1000	IP55/56/65	ABB Process performance motors	M3BP
	0.5 - 90 75 - 630	IP55/56/65 IP55/56/65	ABB Industrial performance motors ABB Industrial performance motors	M3AA M2CA
	0.25 - 630 0.25 - 710	IP55/56/65 IP55/56/65	ABB hazardous area motors - flameproof ABB hazardous area motors - non-sparking (cast iron)	M3JP/KP M3GP

		Pages
An overview of the catalogue and ABB Drives Alliance partners		4 - 5
Drives feature finder - all the features in one table		6 - 7
What's new in drives and motors?		8 - 9
AC motors overview		51
New motor efficiency standard		52
Useful engineering information		58 - 59
Brief description	Why choose this product?	
Simplest variable speed controller No programming – set-up via DIP switches Entry level drive for new users	This drive allows users of direct-on-line (DOL) starting methods to swap to variable speed control. Simple programming interface and programming in the box	 10 - 11
More capable controller with simple keypad and built-in potentiometer. Simple parameter set, but includes PID control For OEMs and machine builders	More capable parameter set allows more applications to be tackled. Built-in keypad and programming in the box. Unified height and depth for easy cabinet layout	 12 - 14
Machinery controller with Safe Torque-Off to SIL 3 capable parameter set - includes eight-step sequencer For OEMs and machine builders, especially F&B industry	Designed for machinery applications, with Assistant keypad, real-time clock. Feedback devices and fieldbus available. IP66 drives meet hygiene standards for F&B industry	 15 - 18
High performance machinery controller with Safe Torque-off to SIL3 Parameters and solution programming to IEC61131 For OEMs and machine builders - Lift OEM's especially	Highly capable DTC platform for synchronous and permanent magnet motors. Complete range of feedback devices, motors and cables available. Special lift software available	 19
Drive equipped with EMC and harmonic filters. The extensive parameter set, vector control and high power density, allows the drive to fit most standard VSD applications	Assistant keypad which makes it user-friendly - numerous standard software functions and macros. Real-time clock. Energy monitoring and energy optimising, everything inside	 20 - 23
Dedicated standard drive for fans and pumps, with fixed quadratic motor fluxing and energy optimisers to optimise fan and pump loads. For fan and pump OEMs and water & waste water applications	Assistant or simple keypad – dedicated pump features. Pump protection, cleaning and pipe fill features. Energy saving counters, fan PID controllers with "sleep" functionality	 24 - 27
Dedicated industrial drive for fans and pumps, with fixed quadratic DTC motor fluxing and energy optimisers to optimise fan and pump loads. Safe Torque-Off to SIL3. Specifically designed for water & waste water applications	Expert control of pumping applications. Multi-pump and multi-master control. Automatic duty standby and pump cleaning. Level control and flow control built-in. Winner of industry innovation award	 37 - 40
Industrial drives are order based expert drives for highly demanding industrial applications of all types. DTC motor control ensures peak performance. Various wall-mounted variants are available, with differing rectifier technologies and built-in options	Standard rectifier, low harmonic or full regeneration can be chosen, then select from a wide range of I/O and feedback options. To complete the selection, industrial drives can be ordered with pre-loaded industry specific software versions which allow quick integration onto winders, cranes, hoists and windmills. Suitable certification also available	 28 - 30
Modules are industrial drives that have been optimised for cabinet installation by system integrators. The routing of cables from top in to bottom out, and the position of options and DC feeding have all been considered for optimal cost effective cabinet integration	Modules are fully supported with CAD databases, EPLAN libraries, with Rittal and generic kits and parts for quick cabinet installation	 31
Cabinet drives are designed, built and tested at the factory and can be ordered with a large range of standard options. Door furniture, motor protection and various cooling variants are possible	Cabinets are fully certified and tested EMC and thermal solutions from the ABB factory, with extensive options	 32 - 36
The ABB drive family contains liquid cooled modules, multidrives and multidrive modules and many more - View these items here		 41 - 43
ABB is able to provide medium voltage drives and motors and DC drives and motor packages - please contact ABB for more details. Industry specific HVAC products are available, containing specific HVAC functionality, macros and interfaces - such as fireman's override. ABB can provide power quality solutions to ensure that drive installations comply to the rigours of G5/4		 44 - 46
Remote monitoring options and PC tools (for drive commissioning and energy calculations)		 47 - 49
Drives service - and ABB University training centre		50



Brief description	Why choose this product?	Pages
The Process performance range provides the most comprehensive and versatile range, meeting the most demanding applications. Designed to deliver reliability and efficiency with the lowest possible environmental impact	Energy efficiency, robust design, reliability	 54
The Industrial process range provides the widest options of frame material with a wide range of options available, designed for the OEM to provide overall reliability and to meet their individual demands	Flexibility, availability, energy efficiency	 55
The range of motors designed for hazardous areas represents one of ABB's special areas of focus. Working together with major companies in the oil & gas, petrochemical & chemical industries, ABB has developed a comprehensive range of products suitable for gas and dust hazardous areas	Safety, reliability, energy efficiency	 56 - 57

ABB drives and motors

Drives and motors products overview

Welcome to the 2010 edition of ABB's drives and motors catalogue. Contained within are the basic technical details and prices for our most commonly used drives and motors products. However, our range of products, systems and services is far more extensive. Extracts from this extended range are given on pages 41-46.



Please do not hesitate to call us for any further information. Our details are on the back cover.

Thank you

Steve Ruddell

Local Division Manager, Discrete Automation and Motion, ABB Ltd.

Lifecycle services

ABB has the largest drive service team of all drive suppliers with field service engineers located throughout the UK and worldwide. Three service levels are available, ensuring exact operational and financial needs can always be met:

DrivesActive

A proactive service that provides 24/7 support with a high level of technical expertise.

DrivesActive+

A proactive service plus a lifecycle management programme that focuses on extending the life of critical equipment.

DrivesAdvantage

A service provided by the ABB Drives Alliance on the current range of products up to 400 kW.

ABB Drives Alliance

ABB Drives Alliance is the UK and Ireland's foremost drives network, bringing levels of service never seen before in the UK and Ireland drives industry. The 12 ABB Drives Alliance partners are strategically located around the UK and Ireland and have one of the largest stocks of AC drives available off-the-shelf. Drives within ABB's UK stock range from 0.18 kW to 400 kW and are instantly available.

Each ABB Drives Alliance partner is able to access up-to-the-minute central stock information using ABB's on-line internet

service. The members of the team have been handpicked by ABB because they are outstanding drives experts in their local area.

ABB Motor Service Partners

ABB Motor Service Partners is a network of 13 independent companies that have pooled their resources to offer national and local customer access to electric motors up to 500 kW. The partners offer extensive technical knowledge and back-up, combined with the best equipped repair and maintenance facilities in Europe. With ABB Motor Service Partners, users benefit from common service standards throughout the UK, common pricing, access to ABB's motor design and technical support, along with standardised reporting functions.

Motion Control Products

Motion Control Products in Bournemouth is a national distributor of ABB's high performance machinery drive, ACSM1 (see page 19). For more information call 07000 DRIVES (07000 374837).

iconsys

iconsys is ABB's partner for the sales and engineering of all DC drive solutions in the UK. As a system integrator, the company offers a complete range of DC drive solutions to the metals, printing and material handling sectors. For more information call 07000 DRIVES (07000 374837).

ABB channel partners



- | | |
|--|---|
| 1. ACS Drives & Control Systems Limited, Ireland
Tel: +353 (0)44 934 0242 | 7. Halcyon Drives, Yorkshire and Greater Manchester
Tel: 0113 236 1509 |
| 2. Advantage Control, Northern Ireland
Tel: 02844 613 782 | 8. Inverter Drives Southern, South
Tel: 01483 766 555 |
| 3. APDS, South West
Tel: 0117 982 2049 | 9. Inverter Drive Systems, East Midlands
Tel: 0115 981 3893 |
| 4. Central Electrical, Merseyside
Tel: 0151 546 6000 | 10. MKE Drive Systems, South East
Tel: 01795 438 436 |
| 5. EDC (Scotland) Limited, Scotland
Tel: 0141 812 3222 | 11. Quantum Controls, North East
Tel: 01661 835 566 |
| 6. Gibbons Drive Systems, East Anglia
Tel: 01621 868 138 | 12. Sentrige Control, Midlands
Tel: 024 7655 3303 |

- | | |
|---|---|
| 1. APDS, South West
Tel: 0117 982 2049 | 8. Francis Chambers & Co, South Yorkshire
Tel: 01709 522 175 |
| 2. Beta Power Engineering, Cheshire
Tel: 0161 432 9995 | 9. Halcyon, West Yorkshire
Tel: 0113 236 1509 |
| 3. Campbell Electric Motors Ltd, Ireland
Tel: +353(0) 1 4628 333 | 10. Heasell Electromechanical Services Ltd, Hertfordshire
Tel: 0871 222 7896 |
| 4. Central Electrical, Merseyside
Tel: 0151 546 6000 | 11. JJ Loughran, Northern Ireland
Tel: 028 8676 2295 |
| 5. CovElec (Leics), Leicestershire
Tel: 0116 269 8111 | 12. MKE Engineering, Kent
Tel: 01795 438 436 |
| 6. EDC (Scotland) Limited, Scotland
Tel: 0141 812 3222 | 13. Quantum Controls, North East
Tel: 01661 835 566 |
| 7. EMR Silverthorn, Middlesex
Tel: 020 8903 6590 | |



ABB drives *Featurefinder*

The table below lists some important features of ABB drives. Its main purpose is to highlight the differences between the various product categories. The table indicates the features available for each product category.



Drive range		ABB component drives (ACS55 - p10) (ACS150 - p12)	ABB general machinery drives (ACS355 - p15)	ABB high performance machinery drive (ACSM1 - p19)
Voltage & power		(ACS55) 1-ph 100 - 120 V: 0.18 - 0.37 kW 1-ph 200 - 240 V: 0.18 - 2.2 kW (ACS150) 3ph 380 - 480 V, 0.37 - 4.0 kW	1-ph 200 - 240 V: 0.37 - 2.2 kW 3-ph 200 - 240 V: 0.37 - 11 kW 3-ph 380 - 480 V: 0.37 - 22 kW	3-ph 380 - 480 V: 0.75 - 110 kW
Other supply options (assume 6-pulse as standard)	12-pulse diode Regenerative low harmonics (4Q) Non-regenerative low harmonics (2Q) Common DC link connectability	- - - -	- - - ●	- - - ●
EMC compliance (EN 61800-3, 2004)	No EMC filter 2nd unrestricted (C3) 1st restricted (C2) 1st unrestricted (C1)	● (or remove EMC screen) ● ■ (150) ●,- (150)	● (remove EMC screw) ● ■ -	● (remove EMC screw) - ■ -
Harmonic filter / choke / active (EN 61000-3-4)	Choke (AC or DC) Swinging choke (better harmonic performance) Low harmonic (best performance)	- ■ -	■ - -	- - ■
Enclosure class	IP00 IP20 IP21 (or near equivalent) IP22 IP42 IP54/ IP54R/ IP55 IP66/69K	- ● ○ (Nema 1, 150) - - - -	- ● ○ (Nema 1) - - - ●	- ● - - - - -
Mechanical construction	Module - panel mountable (IP20 minimum) Wall-mounted (IP21 or equiv. minimum) Free-standing, floor-standing Cabinet built by ABB	●* (DIN mount + screw) ○ (Nema 1, 150)	●* (DIN mount + screw) ○ (Nema 1 kit)	● - - -
Cooling method	Direct air cooling Water cooling Through panel/flange mount Cold plate	● - - -	● - - -	● ○ ○ ○
Dynamic braking chopper	Range of resistors available	- (55), ● (150)	●	●
Switching frequency		4 to 16 kHz	4 to 12 kHz	2 - 16 kHz 5(DTC)
Motor control	DTC (open/closed loop) Sensorless vector Scalar, VVVF	- - ●	- ● ●	● (enhanced) - ●
Programmability	Parameter programming Adaptable IEC61131 programmability	uses dip (55), ● (150) - -	● ● (sequencer) -	● (30%) ● ● (70%)
Start-up assistance and help	Aids to commissioning and diagnostics	-	● (assistant panel)	●
Cold configure	Program the drive whilst still in its box	●	●	-
Removable memory module	No recommissioning	-	-	●
Real-time clock	With Assistant control panel	-	●	■
I/O built-in	Analogue input/output Digital input/output Speed feedback (encoder) Motor thermal protection STO dual channel	1 / 0 3 / 1r (55), 5 / 1r (150) - - -	2 / 1 5 / 1r+1t+(3r) ○ ○ configurable ●	2+(3) / 2+(1) 6+2c+(4) / 3t+1r+(2r) ○ (3 types available)++ ○ configurable ●
+24V live control panel + comms	External 24V supply	-	●	●
Fieldbuses	Modbus Fieldbus interface Drive-to-drive link	- - -	○ ○ -	● ○ ●
Remote monitoring	Report info and status remotely	-	■ (SREA)	■ (SREA)
Safety options (TÜV certified hardware)	Safe Torque-Off (SIL2/BS EN62061) Emergency stop (CAT.0, CAT.1) Safe Torque-Off (SIL3/BS EN62061)	- - -	- - ●	- - ●
ATEX	ATEX certified for use with ABB motor	-	● Ex tD and Ex d only	-
PC tools	DriveConfig tool (programme in box) DriveWindow Light DriveWindow DriveAP DriveStudio (IEC 61131)	■ (55), - (150) - - - -	- ■ - - -	- - - - ■
Industry specific products	HVAC specific Food and beverage Machinery / OEM Water and waste water Industry specific applications	- ○ ● - -	- ● ● ○ ● (IP66/69)	- ○ ● - -

● = standard ○ = option, internal or fitted ■ = option, external - = not available

* = can be bookcase or flat mounted

r = relay output, t= transistor output, c = configurable to be input or output,

[] = ACS850 only

ABB drives *Featurefinder*

Pages 41-46 highlight other AC and DC drives offered by ABB which are not listed within this *Featurefinder*.



ABB standard drives (ACS550 - p20)	ABB standard drives for fans and pumps (ACS310 - p24)	ABB industrial drives for water and waste water (ACQ810-04 - p37)	ABB industrial drives and drive modules (ACS850) (ACS800-01,-02,-04,-11,-14,-31 - p28)	ABB industrial drives cabinet drives (ACS800-07, 17, -37, -p32)
3-ph 208 - 240 V: 0.75 - 75 kW 3-ph 380 - 480 V: 1.1 - 355 kW	3-ph 200 - 240 V: 0.37 - 11 kW 3-ph 380 - 480 V: 0.37 - 22 kW	3-ph 380 - 480 V: 1.1 - 400 kW	3-ph 230 V: 0.55 - 200 kW 3-ph 400 V: 1.1 - 1450 kW 3-ph 500 V: 1.5 - 1850 kW 3-ph 690 V: 5.5 - 1900 kW	3-ph 400 V: 45 - 1450 kW 3-ph 500 V: 55 - 1850 kW 3-ph 690 V: 45 - 2800 kW
-	-	-	○ (>400 kW) ● (800-11, 800-14) ● (800-31)	○ (>400 kW) ● (800-17) ● (800-37)
● (remove EMC screw)	● (remove EMC screen)	○	● (or remove EMC screw)	● (or remove EMC screw)
●	●	●	●	●
■	■	○	○, ■ (800-04 R7/8)	○
-	-	-	-	-
●	■	●, ■ (A,B Frame)	● [○, ■ (A,B frame)]	●
-	-	-	● (800-31)	● (800-37)
-	●	● (G frame) ● (A-E frame)	● (800-04, R7/R8, 800-14) [G frame] ● (800-04, R2 - R6) [A-E frame] ● (800-01, -02, -11, -31)	-
○ (IP54)	○ (Nema 1)	-	○ (800 -01, -11, -31) IP55	○
●	●* (DIN mount + screw) ○ (Nema 1 kit)	●	● (800-04*, 850)	-
● (550-02)	-	-	● (800-02)	●
-	-	-	● (800-02 with enclosure)	●
○ (drive IP54)	-	-	○ (800-04)	● (LC range)
-	-	-	-	○
● (to 11.0 kW), ■ thereafter	●	-	○ [● (to 11.0 kW), ■ thereafter]	○
4 to 12 kHz	4 to 16 kHz	DTC	DTC	DTC
●	-	●	●	●
●	●	●	●	●
●	●	●	● [●, 70%] ● (Drive AP)	● (Drive AP)
-	-	●	● [●, 30%]	-
● (assistant panel)	● (assistant panel)	●	●	●
●	●	-	-	-
-	-	●	[●]	-
●	●	●	[●]	-
2 / 2	2 / 1	2+(3) / 2+(1)	3+(2) / 2+(2) [2+(3) / 2+(1)]	3+(2) / 2+(2)
6 / 3+(3r)	5 / 1r+1t+(3r)	6+2c+(4) / 2r+(2r)	7+(6) / 3+(6r) [6+2c+(4) / 3r+(2r)]	7+(6) / 3+(6r)
○ configurable	○ configurable	○ configurable	○ configurable	○ configurable
-	-	●	○ [●]	○
●	●	●	○ [●]	○
○	-	○	○	○
-	-	●	[●]	-
■ (SREA)	■ (SREA)	■ (SREA)	■ (RETA) ■ (SREA)	■ (RETA)
-	-	-	■	○
-	-	●	[●]	○
● Ex tD and Ex d only	-	-	●	●
-	-	-	-	-
■	■	-	■ (NPCU req.)	■ (NPCU req.)
-	-	-	■ (RDCO req.)	■ (RDCO req.)
-	-	■	■ (RDCO req.)	■ (RDCO req.)
-	-	-	■	-
● (ACH550)	-	-	-	-
○	○	-	○	○
-	●	-	○	○
-	○	●	○	○
● (ACH550)	●	●	xx ○	xx ○

All ABB drives are CE marked
Other global approvals such as UL, cUL, CSA,
C-Tick, GOST-R also applicable

xx = ACS800 can be loaded with industry specific code,
like crane, winder, winch, spinning etc

++ = A wide range of encoder interfaces
to suit high performance applications

What's new in drives

ABB standard drive for pumps and fans, ACS310

- The ABB standard drive family is extended with a new series of drives dedicated for fan and pump loads. It is designed to compliment the functionality of the dedicated ACQ810 (see below).
- With powers up to 22 kW, the drive has a block-style form factor ideally suited for MCC and machine installation
- Ideal for squared-torque applications, such as centrifugal pumps and fans, a dedicated set of software features include:
 - Multi-pump control (traditional PFC)
 - Pump control functions like pipe cleaning, pipe fill and PID control
 - Energy efficiency counters
 - Energy optimiser
 - Full output current up to 50°C
 - Load analyser



ABB general machinery drive, ACS355

- The ABB general machinery drive is upgraded to meet the needs of the new Machinery Directive
- Enhancements are added to give the drive a SIL 3 rated Safe Torque-Off functionality, certified to TÜV standards, BS EN 62061 and BS EN 13849-1
- The drive now comes with a patented common DC feed connection; external 24V connection; the ability to control permanent magnet motors; and an enhanced parameter set



ABB industrial drive for water and waste water, ACQ810

- The ABB industrial drive family is extended with a new series of industry specific drives with dedicated functionality for the water & waste water sector
- With powers up to 400 kW, the drive has a book-style form factor and different mounting options to optimise MCCs
- Specifically designed power modules with tailor-made pump control functions, for single and multi-pump applications include:
 - Multi-pump control, full redundancy and multi-master
 - Pipe cleaning (anti-jam) and pipe fill functions



- Energy efficiency counters, energy optimiser, load analyser
- Level control, flow calculations and full range of pump protections
- Winner of the Electrical Industry Awards, Innovative Industrial Product of the Year 2009 and a finalist in the Pump Industry Awards, 2009.

ABB industrial drive module for system integrators, ACS850

- The ABB industrial drive family is extended to incorporate a dedicated module drive especially designed for system integrators
- Rated up to 400 kW cabinet installation is optimised via a book-style form factor; power (AC and DC) in at the top; motor connections at the bottom
- Drives can be configured to meet precise needs of industrial applications through a wide range of options
- Multiple keypad mounting configurations
- IEC61131 programming built-in
- Extensive range of industrial parameter choices and pre-written software solutions
- Removable memory unit for fast re-commissioning



ABB industrial drives new bypass cabinets, ACS800-07

- Factory-built bypass available, thus allowing cost effective and energy efficient designs
- Use the drive to efficiently control the motor to top speed, with all of the control and protection benefits of a drive, then close the bypass and run DOL (direct-on-line)
- One drive can be used to accelerate multiple motors



ABB high performance machinery drive - ACSM1, enhancements

- Lift specific software
 - with a fully enhanced DTC core and low noise
- Active rectifier front-end
 - New ISU active rectifier front-end for machinery drive, giving full regenerative capability. Ideal for high performance motion, or renewable energy applications
- PLC motion control certified
 - ACSM1, in co-operation with ABB's new PLC, the AC500, has gained motion control certification. Pre-written open software blocks are now present within the PLC



What's new in drives and motors

BS EN 62061 - the new Machinery Directive

ABB's approach features:

1. Built-in Safe Torque-Off (STO) to SIL 3 within the ABB machinery drive range (ACS355 and ACSM1); the ABB industrial drive modules range (ACS850); and the ABB industrial drive module for water and waste water (ACQ810).
 - STO can replace emergency stop contactors in traditional safety circuits, where power removal is not required
 - Other products within the ABB industrial drive range have STO certified to SIL2
2. For more demanding safety solutions, calculations and risk assessments, ABB has formed a partnership with the world leader in safety, Pilz



Energy monitoring built in as standard

- ABB has been committed to saving energy for decades. The 6-step energy saving plan included the first true energy appraisal for saving energy (see page 49).

To enhance the ability of ABB's products to save energy, the ABB standard drive and the ABB industrial drive are enhanced to include a built-in energy saving calculator:

- Drive calculates energy being saved compared to application being controlled DOL (direct-on-line)
- Energy being saved is displayed on keypad in local currency; in tonnes of CO₂ saved; and in kWh and MWh – an ideal feature for energy managers and energy efficient customers



ABB drives and ABB motors - a perfect combination

ABB is one of the few companies in the world to make low voltage AC drives and low voltage AC motors. As such ABB is able to offer the perfectly designed, tested and approved motor-drive combination for any demanding process.

With over 100 years of experience in designing and manufacturing low voltage AC motors, ABB is well suited to meet the challenging demands of efficient power production. And as one of the founders of low voltage AC drives, there are very few applications in the world that do not feature a motor and drive combination from ABB.

ABB's AC drives are able to control ABB's AC motors over a power range from 100 W to 100 MW and are the most modern in the market place. ABB offers the lowest life cycle cost for each motor and drive, generating higher productivity, higher operating efficiency and minimal environmental impact.



ABB component drive

0.18 kW to 2.2 kW, ACS55

Supply voltage 110 - 240 V, 200 - 240 V

Motor control method - scalar

What is an ABB component drive, ACS55?

The ABB component drive meets the requirements of OEMs, machinery builders and panel builders. It is a component that is bought, together with other components, from a logistical distributor. The aim is for the ABB component drive to be so small and simple, that users of contactors and softstarters are encouraged to move to the benefits of variable speed control. There are two variants in the ABB component drive family: ACS55 and ACS150 (see page 12). The ACS55 is the simplest drive, programmed by switches. Extended programming is possible via a PC if required, as is programming without power.

Where can it be used?

- Washing machines
- Mixers
- Boring machines
- Pizza ovens
- Vacuum cleaners
- Sliding doors
- Dryers
- Dishwashers
- Treadmills
- Car washing machines
- Rotating billboards
- Electric gates

Highlights - ACS55

- Quick and easy installation - less than 5 minutes
- No programming - easy and descriptive interface
- Can be programmed via DriveConfig if needed to access extended functions (useful to OEMs)
- Compact size and narrow shape
- Ideal drive for DIN-rail mounting
- 110 V single phase – input gives 240 V, 3-phase output
- Two mounting orientations



For more details, please refer to Technical Catalogue 3AFE68899842

- IP20 as standard
- No control panel required
- User interface via three rotary switches and a further eight on/off function DIP switches located on panel front
- Potentiometer option
- Integral EMC filter for 1st environment (EN61800-3), unrestricted distribution (C1)
- Optional first environment filter for extended cable runs
- Optimised switching frequency for low noise (up to 16 kHz)
- Silent motor

ACS55 - main features

Feature	Advantage	Benefit
No programming if required	Inverter parameter settings with DIP switches and potentiometers. Extended programming is possible via DriveConfig if needed	Faster set-up Easier configuration Easy drive for new users
Compact size and narrow shape	Up to 0.37 kW, 45 mm width; 2.2 kW, 67.5 mm width	Less space required for installation
Removable mounting clip	Removable clip allows DIN-rail and wall-mounting from back and side of the unit	Flexible and easy mounting
DriveConfig kit	Fast and safe configuration of an unpowered drive	Simple programming for high volume OEMs - programming in the box, no mains power needed
EMC	First environment. C1 EMC filters as standard ('E' model)	Low EMC emissions
Automatic switching frequency	Increases switching frequency automatically, when drive temperature is decreased	Provides lowest possible noise without derating of the drive
110-240 V AC, single phase supplies	Output always capable of full 240 V, 3-phase, regardless of supply voltage	Can easily replace single phase cap start motors
RoHS compliance	Compliance achieved during 2007	Environmentally friendly drives

ABB component drive

ACS55 – Ratings, types, voltages, prices and dimensions

200/240 V, 1-phase supply, 3-phase output 200/240 V

Nominal ratings				Frame	Fuse A Type gG	Heat dissipation W	Cooling requirements m³/h	Type	Price
Nominal kW	Input current A	Nom. output current A	Max output A						
With EMC filter									
0.18	4.4	1.4	2.1	A	10	21	* Nat Vent	ACS55-01E-01A4-2	£86
0.37	6.9	2.2	3.3	A	16	32	* Nat Vent	ACS55-01E-02A2-2	£95
0.75	10.8	4.3	6.5	B	16	51	* Nat Vent	ACS55-01E-04A3-2	£113
1.5	18.2	7.6	11.4	D	25	74	26	ACS55-01E-07A6-2	£158
2.2	22	9.8	14.7	D	32	103	26	ACS55-01E-09A8-2	£185
Without EMC filter									
0.18	4.4	1.4	2.1	A	10	21	* Nat Vent	ACS55-01N-01A4-2	£81
0.37	6.9	2.2	3.3	A	16	32	* Nat Vent	ACS55-01N-02A2-2	£90
0.75	10.8	4.3	6.5	B	16	51	* Nat Vent	ACS55-01N-04A3-2	£105
1.5	18.2	7.6	11.4	C	25	74	26	ACS55-01N-07A6-2	£147
2.2	22	9.8	14.7	C	32	103	26	ACS55-01N-09A8-2	£173

* Ensure minimum installation space is provided, see User's Manual for details

100/120 V, 1-phase supply, 3-phase output 200/240 V

Nominal ratings				Frame	Fuse A Type gG	Heat dissipation W	Cooling requirements m³/h	Type	Price
Nominal kW	Input current A	Nom. output current A	Max output A						
With EMC filter									
0.18	6.4	1.4	2.1	A	10	24	* Nat Vent	ACS55-01E-01A4-1	£94
0.37	9.5	2.2	3.3	A	16	35	* Nat Vent	ACS55-01E-02A2-1	£104
Without EMC filter									
0.18	6.4	1.4	2.1	A	10	24	* Nat Vent	ACS55-01N-01A4-1	£91
0.37	9.5	2.2	3.3	A	16	35	* Nat Vent	ACS55-01N-02A2-1	£98

* Ensure minimum installation space is provided, see User's Manual for details

Drive dimensions and weights

Frame size	H1 mm	H2 mm	W mm	D mm	Weight Kg
A	170	146.5	45	128	0.65
B	170	146.5	67.5	128	0.70
C	194	171	70	159	1.1
D	226	203	70	159	1.1

H1 = Height with mounting clip
H2 = Height without mounting clip
W = Width
D = Depth

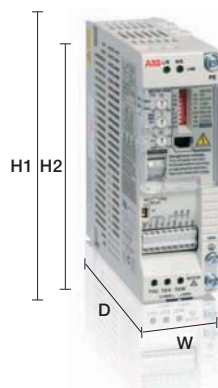

ACS55 typical I/O connections

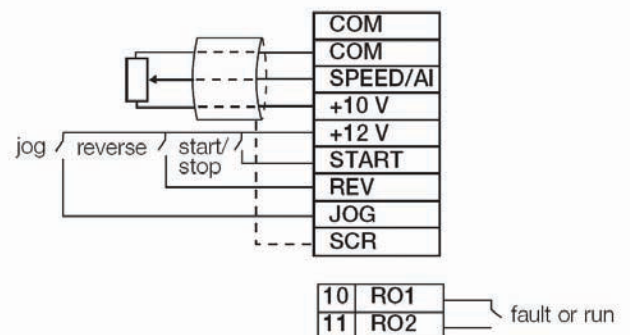

Options and interfaces

Potentiometer

Potentiometer with two switches: start/stop and forward/reverse direction. No external power source is needed for the potentiometer.



DriveConfig programming with no power

To increase the number of applications possible with the ACS55, the DriveConfig kit can be used to access an extended parameter set. It is still possible to programme in the usual way, if these extended features are not required. DriveConfig also allows programming in the box.



ABB component drive

0.37 kW to 4 kW, ACS150

Supply voltage, 200 - 240 V, 380 - 480 V, single-phase and 3-phase

Motor control method - scalar

What is an ABB component drive, ACS150?

The ABB component drive meets the requirements of OEMs, machinery builders and panel builders. It is a component that is bought, together with other components, from a logistical distributor. Component drives are designed to encourage users of contactors and softstarters to move to the benefits of variable speed control. The ACS150 extends the capability of the ACS55 (see page 10), by adding an extended range of power frames and programmability. The ACS150 can solve more difficult tasks like PID functionality. To retain the simplicity of an ABB component drive, the ACS150 does not have a serial communications interface or extended options, but does have a fixed keypad and speed control potentiometer.

Where can it be used?

ACS150 can be used to control less demanding components in any machine, fans or pumps or anywhere where a fixed speed motor needs to go to variable speed control. The functionality of the drive is designed to compliment the ABB general machinery drives and ABB high performance machinery drives.

Highlights - ACS150

- PID controller built-in
- DC hold stop ensures stationary motor shaft
- IR compensation improves starting torque for heavy loads
- Parameter lock prevents tampering by unauthorised staff
- DIN rail or screw mounting as standard



For more details, please refer to Technical Catalogue 3AFE68596114

- IP20 enclosure
- Fixed basic control panel
- Dedicated control potentiometer
- 2-year warranty
- Flashdrop - parameter programming whilst still in its box - excellent for OEMs
- Protected against wiring errors; shows fault if power cable is inadvertently connected to motor terminals
- Automatic noise reduction
- Optional short or long parameter mode for standard or advanced usage
- Unified height across the power range simplifies cabinet design

ACS150 - main features

Feature	Advantage	Benefit
FlashDrop*	Faster and easier drive set-up and commissioning for volume manufacturing - programming in the box	No need for high voltage safe areas Parameters can be hidden for clarity Programme the drive during machine production build-up
Fixed interface	Simple drive with comfortable and robust interface	Integrated control panel with clear LCD display, backlight and buttons for editing and control
Fixed potentiometer	Intuitive speed setting	Integrated potentiometer. Settings shown on the control panel
Programmable functions	Useful control functions like PID, accelerating rates and start/stop modes included	Take control of the motor and reduce cost in the installation
Built-in EMC filter	No need for external filtering	2nd environment built-in filter. Complying with IEC 61800-3 as standard
Built-in brake chopper	Reduced cost, saved space and simple wiring	100% braking capability
Flexible installation	Optimum layout and efficient cabinet space usage	Screw, DIN-rail, sideways and side-by-side mounting Unified height and depth
Drive protection	Latest solutions to protect the drive and offer trouble-free use and the highest quality	The drive protects itself when power is connected to the motor terminals. I/O protected against short-circuit. Coated boards included as standard
Brand labelling	Drive logo, control panel logo, manuals and box can be printed with machine builders logo and name	Drives and packaging badged to your design
RoHS compliance	Compliance achieved during 2007	Environmentally friendly drives

* For details of FlashDrop, see user interfaces in ABB general machinery drive section (page 18)

ABB component drive

ACS150 – Ratings, types, voltages and prices

1-phase supply voltage 200-240 V

Nominal ratings		Max Output A	Frame	Fuse A Type gG	Heat dissipation W	Cooling requirements m³/h	Type	Price
Nominal kW	Nom. output current A							
0.37	2.4	4.2	R0	10	25	*Nat Vent	ACS150-01E-02A4-2	£93
0.75	4.7	8.2	R1	16	46	24	ACS150-01E-04A7-2	£108
1.1	6.7	11.7	R1	20	71	24	ACS150-01E-06A7-2	£137
1.5	7.5	13.1	R2	25	73	21	ACS150-01E-07A5-2	£153
2.2	9.8	17.2	R2	35	96	21	ACS150-01E-09A8-2	£184

* Ensure enough space around the unit - refer to the User's Manual for details

3-phase supply voltage 200-240 V

Nominal ratings		Max Output A	Frame	Fuse A Type gG	Heat dissipation W	Cooling requirements m³/h	Type	Price
Nominal kW	Nom. output current A							
0.37	2.4	4.2	R0	10	19	*Nat Vent	ACS150-03E-02A4-2	£156
0.55	3.5	6.1	R0	10	31	*Nat Vent	ACS150-03E-03A5-2	£165
0.75	4.7	8.2	R1	10	38	24	ACS150-03E-04A7-2	£198
1.1	6.7	11.7	R1	16	60	24	ACS150-03E-06A7-2	£220
1.5	7.5	13.1	R1	16	62	21	ACS150-03E-07A5-2	£224
2.2	9.8	17.2	R2	16	83	21	ACS150-03E-09A8-2	£338

* Ensure enough space around the unit - refer to the User's Manual for details

3-phase supply voltage 380-480 V

Nominal ratings		Max Output A	Frame	Fuse A Type gG	Heat dissipation W	Cooling requirements m³/h	Type	Price
Nominal kW	Nom. output current A							
0.37	1.2	2.1	R0	10	11	*Nat Vent	ACS150-03E-01A2-4	£147
0.55	1.9	3.3	R0	10	16	*Nat Vent	ACS150-03E-01A9-4	£156
0.75	2.4	4.2	R1	10	21	13	ACS150-03E-02A4-4	£170
1.1	3.3	5.8	R1	10	31	13	ACS150-03E-03A3-4	£187
1.5	4.1	7.2	R1	16	40	13	ACS150-03E-04A1-4	£204
2.2	5.6	9.8	R1	16	61	19	ACS150-03E-05A6-4	£293
3	7.3	12.8	R1	16	74	24	ACS150-03E-07A3-4	£353
4	8.8	15.4	R1	20	94	24	ACS150-03E-08A8-4	£401

* Ensure enough space around the unit - refer to the User's Manual for details

The drive can be fitted with the NEMA 1 kit for easy wall-mounting and convenient protection, see page 18 under ABB general machinery drive

ABB component drive

ACS150 – Dimensions, I/O and options

Drive dimensions and weights

Cabinet-mounted drives (UL open), wall mounted drives (NEMA 1)

Frame size	IP20 UL open					NEMA 1					
	H1	H2	H3	W	D	Weight	H4	H5	W	D	Weight
	mm	mm	mm	mm	mm	Kg	mm	mm	mm	mm	Kg
R0	169	202	239	70	142	1.1	257	280	70	142	1.5
R1	169	202	239	70	142	1.3	257	280	70	142	1.5
R2	169	202	239	105	142	1.5	257	282	105	142	1.5

H1 = Height without fastenings and clamping plate
 H2 = Height with fastenings but without clamping plate
 H3 = Height with fastenings and clamping plate
 H4 = Height with fastenings and NEMA 1 connection box
 H5 = Height with fastenings, NEMA 1 connection box and hood
 W = Width
 D = Depth



Options available

- Input and output chokes
- Brake chopper resistors (all drives in the ACS150 range have integral chopper)
- 1st. environment EMC filters - footprint style
- Low leakage EMC filters < 30mA leakage
- FlashDrop - programming without power

ACS150 typical I/O connections

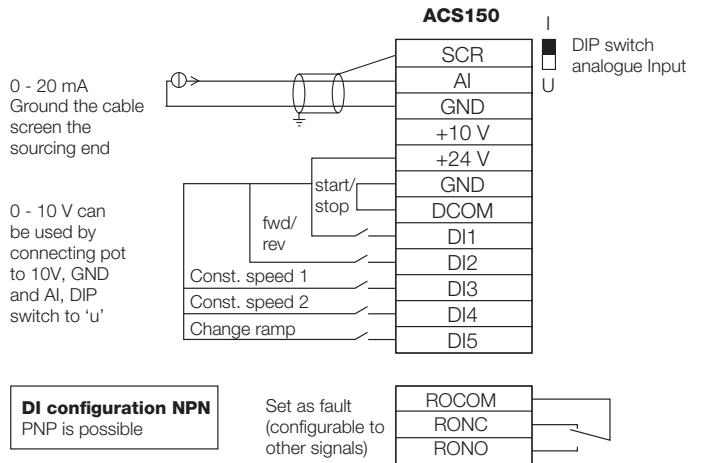

ACS150 user interfaces

The ACS150 has a simple user interface, consisting of I/O connections and a fixed programming keypad. An integrated speed control potentiometer is also provided.



ABB general machinery drive

0.37 kW to 22 kW, ACS355

Supply voltage 200 - 480 V, single-phase and 3-phase

Motor control method - scalar, vector (open and closed loop)

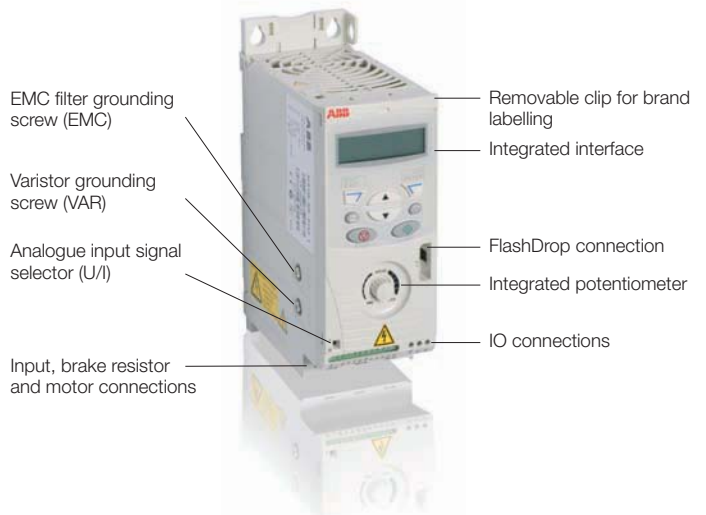
What is an ABB general machinery drive?

ABB general machinery drives are designed for the machine building sector. In serial type manufacturing the consumed time per unit is critical. The drive is designed to be optimal in terms of installation, setting parameters, available machinery features and commissioning. The basic product has been made as user-friendly as possible, yet providing high intelligence. The drive offers diverse functionality to cater for the most demanding needs. The drive is also equipped with a Safe Torque-Off interface to SIL3.

Where can it be used?

ABB general machinery drives are designed to meet the requirements of an extensive range of machinery applications. The drive is ideal for food and beverage, material handling, textile, printing, rubber and plastics and woodworking applications. The higher IP class variant meets all of the relevant hygiene requirements for the food and beverage industry.

The functionality of this ABB drive is designed to complement the ABB high performance machinery drive and the ABB component drives.

Highlights - ACS355

- FlashDrop - parameter programming with drive still in its box - excellent for OEMs

Main features

Feature	Advantage	Benefit
FlashDrop*	Faster and easier drive set up and commissioning for volume manufacturing	Fast, safe and trouble-free method to set up and commission without powering up the drive - patented
Safe Torque-Off	Built-in compliance to new Machinery Directive	SIL3 certified dual channel input - TÜV approved
Sequence programming	Application specific 8-state programming with comprehensive triggering conditions	Logic programming included as standard Reduces the need for external PLC
Common DC link	Connection to existing DC power sources	Easy integration into high performance machines
User interfaces	Wide range, including Assistant panel - see options	Cost efficient approach - according to requirements of OEM
Fieldbus	Extensive range of industrial fieldbus option modules available	Connectability to all of the most popular fieldbuses in use
24 V 'live keypad' operation	Connect 24 V to the drive via the MPOW option	Keep fieldbus, control card and I/O healthy while able to remove the main supply - safer maintenance
Built-in EMC filter	2nd environment filter complying with IEC 61800-3 as standard	No extra space, parts, time or cost required
Built-in brake chopper	100% braking capability	Reduces cost, saves space and simplifies wiring
Drive protection	Latest solutions to protect the drive and offer trouble-free use and the highest quality	The drive protects itself when power is connected to the motor terminals. I/O protected against short-circuit Coated boards included as standard
IP66/69k enclosure option	Makes drive suitable for hose down applications	Meets food hygiene standards in a wall-mounted enclosure
Brand labelling	Drive logo, control panel logo, manuals and box can be printed with machine builders logo and name	Drives and packaging badged to your design
RoHS compliance	Compliance achieved during 2007	Environmentally friendly drives

* For details of FlashDrop, see user interfaces in ABB general machinery drive section (page 18)



For more details, please refer to Technical Catalogue 3AFE68596106

- Sequence programming designed for food and beverage and materials handling applications - 8-steps included
- Impressive software and compact hardware
- Optimised interfaces for users and machines (can select Basic or Assistant panel)
- Drive branding possible for large users
- Protected against wiring errors; shows fault if power cable is inadvertently connected to motor terminals
- Automatic noise reduction
- Unified height and depth across the power range simplifies cabinet design

ABB general machinery drive

ACS355 - Ratings, types, voltages and prices

1-phase supply voltage 200-240 V

Nominal ratings		Max Output A	Frame	Fuse A Type gG	Heat dissipation W	Cooling requirements m³/h	Type	IP20 price without control panel*	IP66 price with control panel**
Nominal kW	Nom. output current A								
0.37	2.4	4.2	R0	10	48	+Nat Vent	ACS355-01E-02A4-2	£102	n/a
0.75	4.7	8.2	R1	16	72	24	ACS355-01E-04A7-2	£129	n/a
1.1	6.7	11.7	R1	20	97	24	ACS355-01E-06A7-2	£151	n/a
1.5	7.5	13.1	R2	25	101	21	ACS355-01E-07A5-2	£166	n/a
2.2	9.8	17.2	R2	35	124	21	ACS355-01E-09A8-2	£203	n/a

* Ensure enough space around the unit - refer to the User's Manual for details

3-phase supply voltage 200-240 V

Nominal ratings		Max Output A	Frame	Fuse A Type gG	Heat dissipation W	Cooling requirements m³/h	Type	IP20 price without control panel*	IP66 price with control panel**
Nominal kW	Nom. output current A								
0.37	2.4	4.2	R0	10	42	+Nat Vent	ACS355-03E-02A4-2	£172	£445
0.55	3.5	6.1	R0	10	54	+Nat Vent	ACS355-03E-03A5-2	£180	£449
0.75	4.7	8.2	R1	10	64	24	ACS355-03E-04A7-2	£218	£519
1.1	6.7	11.7	R1	16	86	24	ACS355-03E-06A7-2	£241	£550
1.5	7.5	13.1	R1	16	88	21	ACS355-03E-07A5-2	£280	£600
2.2	9.8	17.2	R2	16	111	21	ACS355-03E-09A8-2	£367	£769
3	13.3	23.3	R2	25	140	52	ACS355-03E-13A3-2	£423	£1,023
4	17.6	30.8	R2	25	180	52	ACS355-03E-17A6-2	£454	£1,239
5.5	24.4	42.7	R3	63	285	71	ACS355-03E-24A4-2	£608	n/a
7.5	31.0	54.3	R4	80	328	96	ACS355-03E-31A0-2	£810	n/a
11	46.2	80.9	R4	100	488	96	ACS355-01E-46A2-2	£1,055	n/a

* Ensure enough space around the unit - refer to the User's Manual for details

3-phase supply voltage 380-480 V

Nominal ratings		Max Output A	Frame	Fuse A Type gG	Heat dissipation W	Cooling requirements m³/h	Type	IP20 price without control panel*	IP66 price with control panel**
Nominal kW	Nom. output current A								
0.37	1.2	2.1	R0	10	35	+Nat Vent	ACS355-03E-01A2-4	£176	£373
0.55	1.9	3.3	R0	10	40	+Nat Vent	ACS355-03E-01A9-4	£185	£375
0.75	2.4	4.2	R1	10	50	13	ACS355-03E-02A4-4	£202	£388
1.1	3.3	5.8	R1	10	60	13	ACS355-03E-03A3-4	£230	£431
1.5	4.1	7.2	R1	16	69	13	ACS355-03E-04A1-4	£280	£490
2.2	5.6	9.8	R1	16	90	19	ACS355-03E-05A6-4	£324	£560
3	7.3	12.8	R1	16	107	24	ACS355-03E-07A3-4	£423	£724
4	8.8	15.4	R1	20	127	24	ACS355-03E-08A8-4	£481	£822
5.5	12.5	21.9	R3	25	161	52	ACS355-03E-12A5-4	£559	£973
7.5	15.6	27.3	R3	30	204	52	ACS355-03E-15A6-4	£724	£1,154
11	23.1	40.4	R3	50	301	71	ACS355-03E-23A1-4	£885	n/a
15	31.0	54.3	R4	80	408	96	ACS355-03E-31A0-4	£1,135	n/a
18.5	38.0	66.5	R4	100	498	96	ACS355-03E-38A0-4	£1,346	n/a
22	44.0	77.0	R4	100	588	96	ACS355-01E-44A0-4	£1,646	n/a

* Ensure enough space around the unit - refer to the User's Manual for details

* Note: IP21 drives require a keypad for parameter alteration

** Note: IP66 drives are always delivered with the Assistant keypad

ABB general machinery drive

ACS355 – Dimensions, I/O and options

Control panel for ACS355

Control panel	Type	Price
Assistant control panel	ACS-CP-A	£80**
Basic keypad	ACS-CP-C	£21

** Price of control panel only when purchased with drive
Panel mounting kit and user interface descriptions, see page 18



Drive dimensions and weights

Frame size	IP20 UL Open							NEMA 1/UL Type 1							IP66/67/UL Type 4x			
	H1	H2	H3	W	D1	D2	Weight	H4	H5	W	D1	D2	Weight	H	W	D1	Weight	
R0	169	202	239	70	161	187	1.2	257	280	70	169	187	1.6	-	-	-	-	
R1	169	202	239	70	161	187	1.2	257	280	70	169	187	1.6	305	195	281	7.7	
R2	169	202	239	105	165	191	1.5	257	282	105	169	191	1.9	-	-	-	-	
R3	169	202	236	169	169	195	2.5	260	299	169	177	195	3.1	436	246	277	13	
R4	181	202	244	260	169	195	4.4	270	320	260	177	195	5.0	-	-	-	-	

H = Height
H1= Height without fastenings and clamping plate
H2 = Height with fastenings but without clamping plate
H3 = Height with fastenings and clamping plate
H4 = Height with fastenings and NEMA 1 connection box
H5 = Height with fastenings, NEMA 1 connection box and hood
W = Width
D1 = Standard depth
D2 = Depth with MREL or MTAC option

STO connections

The ACS355 has a dual channel STO (Safe Torque-Off) input available, certified to BS EN 62061 and BS EN 13849-1

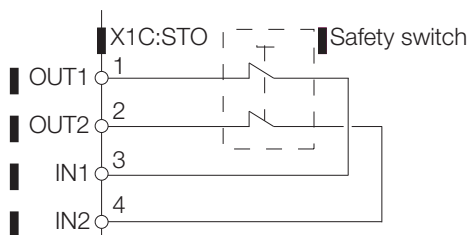

Options available

- Input and output chokes
- Brake chopper resistors (all drives in the ACS355 range have integral chopper)
- 1st. environment EMC filters - footprint style
- Low leakage EMC filters < 30mA leakage
- FlashDrop
- Fieldbus modules
- An extensive range of user interfaces is available - please see following pages

Typical control connections



ABB general machinery drive

ACS355 – User interfaces

Assistant control panel

The Assistant control panel features a multilingual alphanumeric display for easy drive programming. The control panel has various assistants and a built-in help function to guide the user. It includes a real-time clock, which can be used during fault logging and in controlling the drive, such as start/stop. The control panel can be used for copying parameters for backup or for downloading to another drive. A large graphical display and soft keys make it extremely easy to navigate. For further information, see ABB standard drive section on page 23.

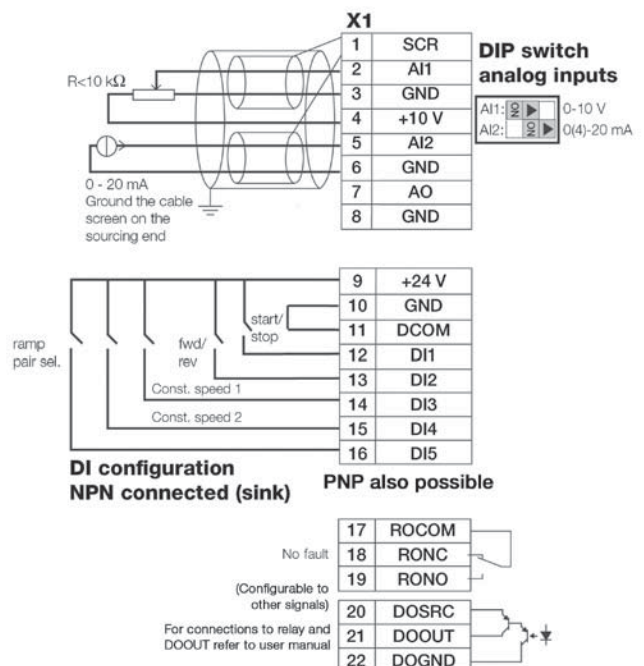

Basic control panel

The Basic control panel features a single line numeric display. The panel can be used to control the drive, set the parameter values or copy them from one drive to another, or view changes.



Panel cover

The panel cover protects the drive's connection surfaces. The ABB general machinery drive is delivered with a panel cover as standard. In addition, there are two alternative control panels available as options, see above.



NEMA 1 kit

The NEMA 1 kit is a convenient cover which is added to the drive and enables easy wall-mounting. It includes a connection box for finger protection, conduit tube installation and a hood for protection against dirt and dust.



Panel mounting kit, IP54 and IP66

The panel mounting kit enables mounting of control panels on cabinet doors. These kits include a 3 m extension cable, a gasket, mounting screws and a mounting template - two versions are now available, IP54 and IP66. The IP66 has an additional keypad membrane cover.



Relay extension module

Add an additional three relays to the ACS355 to allow greater use of the drives program. Fits behind the keypad.



Potentiometer

Potentiometer with two switches: start/stop and forward/reverse direction. No external power source is needed for the potentiometer. Fits to the drive.



FlashDrop

Programme the drive whilst still in the box, with no power. Perfect for OEMs and machine builders. FlashDrop is a powerful palm-sized tool for fast and easy parameter selecting and setting. It gives the possibility to hide selected parameters to protect the machine. The tool stores 20 parameter sets, which can be moved between a PC and a drive. Safe programming during machine building production.



Fieldbus interfaces

Extensive range of plug-in fieldbus interfaces, allowing connection to Profibus, DeviceNet, CanOpen, Modbus RTU and Ethernet, and others



24V "live keypad" options

There are two ways of powering the fieldbus modules, so that they operate when the main power is removed.



FEPA - maintains power to the fieldbus module only

MPOW - Powers the fieldbus module, the control card, the drive I/O and the drive keypad, generating the functionality commonly known as 'live keypad' operation.



DriveWindow Light PC tool

DriveWindow Light is a parameterisation and commissioning tool used to set-up and commission the drive. Monitoring and diagnostic facilities are included, as well as a local control panel. Wizards are included to guide the user through the most commonly performed tasks.

ABB high performance machinery drive

0.75 kW to 110 kW, ACSM1

Supply voltage 380 - 480 V

Motor control method - Enhanced DTC



What is an ABB high performance machinery drive?

ABB high performance machinery drives provide high performance torque, speed and motion control for demanding machines. The following is an overview. For more information please contact ABB.

Where can it be used?

ABB high performance machinery drives can control standard induction asynchronous motors as well as permanent magnet synchronous servo motors with a variety of feedback devices.

ABB high performance machinery drives are ideal for any demanding machinery application, including:

- Printing
- Film and foil converting
- Cranes
- Elevators/lifts
- Automatic storage
- Flying and rotary shears
- Winders
- Packaging machines
- Textile machines
- Wire and cable machinery

Highlights

- For demanding machinery applications
- One drive for all motor types
- For synchronous and induction motors
- Adaptable design with modular, compact hardware
- Memory unit for easy drive management and re-commissioning
- Wide range of feedback interfaces
- Solution programming to extend drive functions, DriveStudio (IEC61131 compatible)
- Modular and compact design, includes the functionality needed for the application
- Safe Torque-Off (SIL3 rated), TÜV approved
- Complemented by the ABB general machinery drive (see pages 15-18)
- Further control options can be realised when the drive is used with the ABB AC500 PLC

Common DC link and regenerative capability

The ABB high performance machinery drive can also be supplied with an active rectifier. This allows common DC link schemes to be designed. Other drives can be supplied by this common DC link, including the ABB general machinery drive. Full regenerative capability is possible with this rectifier and renewable energy applications become possible.

Lift/elevator control

Specific lift/elevator application control program available, tailored for the lift industry



For more details, please refer to Technical Catalogue 3AFE68675073

Speed and torque control

- Open and closed loop DTC
- For synchronous and asynchronous motors

Motion control

In addition to speed and torque control, ABB high performance machinery drive also offers motion control:

- Point-to-point positioning with extensible positioning profile sets
- Synchronisation (encoder feedback or drive-to-drive link)
- Register control based on fast probe inputs
- Multiple homing methods
- Pre-written motion blocks for ABB PLCs



DTC (direct torque control)

ABB's highly accurate motor control platform, has gained extensive acceptance from ABB industrial drive customers for over a decade. DTC fulfils demanding machine builders' requirements.

Motors

ABB can also supply suitable motors and cable sets to complete the machinery drive offering.



9C range

HDP range

MS range

MS range

ABB standard drive

0.75 kW to 355 kW, ACS550

Supply voltage 380-480 V (230 V)

Motor control method - scalar, vector (open and closed loop)

What is an ABB standard drive?

The ABB standard drive is simple to buy, install, configure and use, saving considerable time. It is widely available through ABB's distributors. The drive has common user and process interface, common software tools for sizing, commissioning, maintenance and common spare parts. A wide range of fieldbus options gives excellent connectivity and new energy monitoring allows energy management.

Where can it be used?

The ABB standard drive can be used in a wide range of industries. Typical applications include pump and fan, amongst many others. The vector motor control means the drive can be used to fulfil the needs of reasonably demanding applications. For highly demanding torque applications, the ABB industrial drive with DTC should be chosen. The ABB standard drive is ideal in those situations where there is a need for simplicity to install, commission and use and where reasonable amounts of flexibility and functionality are required.

Highlights, ACS550

- Quick installation
- Rapid start-up
- Trouble-free use
- Easy interfacing
- Wide power range in wall-mounted IP21 and IP54 variants



For more details, please refer to Technical Catalogue 3AFE64792857

- Assistant control panel for intuitive use
- Patent pending swinging choke for superior harmonic reduction
- Sensorless vector and scalar control
- Integral EMC filter for 1st and 2nd environment as standard
- Flexible fieldbus system with built-in Modbus and numerous internally mountable fieldbus adapters
- New energy monitoring features record energy, CO₂ and money saved

Main features

Feature	Advantage	Benefit
FlashDrop*	Faster and easier drive set up and commissioning for volume manufacturing	Fast, safe and trouble-free method of programming available without powering up the drive - patented
Application macros	Ready-made macros for common applications	Fast single parameter set-up
Assistant control panel	Two softkeys, function of which changes according to the state of the panel. Built-in "Help" button, giving programming hints. Real-time clock, allows timed tracing of faults and setting of parameters to activate functions at various times of day. Changed parameters menu also included	Easy commissioning - Start-up assistant User friendly maintenance - Maintenance assistant Rapid fault diagnosis - Diagnostic assistant Quick access to all parameter changes - separate list
Clone drives	Copy parameters from drives of differing rating or software versions	Easy to copy parameters to other drives, reducing commissioning times
Programmable customer load curve	8-point load curve set during commissioning, with under and overload regions, as well as alarm conditions	Allows precise monitoring of changes in plant conditions and early warning of potential problems
Brake chopper	Built-in up to 11 kW	Reduced cost
Chokes	Swinging DC chokes - matches the right inductance to the right load, thereby suppressing and reducing harmonics	Reduces Total Harmonic Distortion (THD) emissions up to 25%
EMC	1st and 2nd environment RFI filters as standard	No need for additional external filtering
Fieldbus	Built-in Modbus using RS 485 Optional plug-in fieldbus modules	Reduced cost, full access to industrial networks
Sensorless vector control	Improved motor control performance	Enables wider range of applications to be tackled
Low peak volts and du/dt	Motor peak voltage and rate of rise meets IEC60034-17	Kind to motor windings
RoHS compliance	Compliance achieved during 2007	Environmentally friendly drives

* For details of FlashDrop, see user interfaces (page 23)

ABB standard drive

ACS550 – Variants, ratings, types, voltages and prices

ABB standard drive variants

Wall-mounted - 0.75 to 160 kW, 380 - 480 V (230 V also available)

- Wall-mounted, frame sizes R1-R6
- IP21 as standard, IP54 as option
- 55% size reduction at 160 kW
- Built-in EMC filter
- Standard software, easy to configure
- Built-in Modbus interface
- Cable connection box
- Brake chopper in frame sizes R1-R2
- Assistant control panel
- Built-in patented swinging choke
- Sensorless vector control, scalar control
- FlashDrop compatible
- RoHS compliant



Free-standing - 110 to 355 kW, 380 - 480 V

- Free-standing, frame sizes R7-R8
- IP21 as standard, very compact design
- Built-in EMC filter
- Standard software, easy to configure
- Built-in Modbus interface
- Pedestal unit on wheels, easy handling
- Assistant control panel
- Sensorless vector control, scalar control
- Free-standing units are not FlashDrop compatible
- Not RoHs compliant
- For dimensions and prices, please contact ABB



Types, ratings and dimensions

3-phase supply voltage 380-480 V

† Ratings Normal use		Frame A	Fuse A Type gG	Heat dissipation W	Cooling requirements m³/h	Type	IP21 price without control panel*	IP54 price without control panel*
P _N kW	I _{2N} A							
1.1	3.3	R1	10	40	44	ACS550-01-03A3-4	£380	£450
1.5	4.1	R1	10	52	44	ACS550-01-04A1-4	£480	£530
2.2	5.4	R1	10	73	44	ACS550-01-05A4-4	£500	£560
3	6.9	R1	10	97	44	ACS550-01-06A9-4	£550	£600
4	8.8	R1	10	127	44	ACS550-01-08A8-4	£620	£700
5.5	11.9	R1	16	172	44	ACS550-01-012A-4	£750	£800
7.5	15.4	R2	16	232	88	ACS550-01-015A-4	£870	£940
11	23	R2	25	337	88	ACS550-01-023A-4	£1,060	£1,120
15	31	R3	35	457	134	ACS550-01-031A-4	£1,360	£1,480
18.5	38	R3	50	562	134	ACS550-01-038A-4	£1,770	£1,900
22	45	R3	50	667	134	ACS550-01-045A-4	£2,070	£2,170
30	59	R4	63	907	280	ACS550-01-059A-4	£2,520	£2,710
37	72	R4	80	1120	280	ACS550-01-072A-4	£2,920	£3,100
45	87	R4	125	1440	280	ACS550-01-087A-4	£3,610	£3,860
55	125	R5	160	1940	350	ACS550-01-125A-4	£4,269	£4,565
75	157	R6	200	2310	405	ACS550-01-157A-4	£4,589	£4,885
90	180	R6	250	2810	405	ACS550-01-180A-4	£5,841	£6,324
110	195	R6	250	3050	405	ACS550-01-195A-4	£7,052	£7,535
132	245	R6a	250	3050	405	ACS550-01-246A-4	£8,661	£9,144
160	290	R6a	350	3050	405	ACS550-01-290A-4	£10,236	£10,719

Includes EMC Filter

* Control panel is required for programming and set-up - see below

† Heavy duty ratings available, when higher overload requirements are needed; contact ABB

Control panel for ACS550

Control panel	Type	Price
Assistant control panel	ACS-CP-A	£80**

** Price of control panel only when purchased with drive

ABB standard drive

ACS550 – Dimensions, I/O and options

Drive dimensions and weights

Frame size	IP21 / UL open					IP54 / UL type 12				
	H1	H2	W	D	Weight	H	W	D	Weight	
	mm	mm	mm	mm	Kg	mm	mm	mm	Kg	
R1	369	330	125	212	6.5	449	213	234	8.2	
R2	469	430	125	222	9	549	213	245	11.2	
R3	583	490	203	231	16	611	257	253	18.5	
R4	689	596	203	262	24	742	257	284	26.5	
R5	739	602	265	286	34	776	369	309	38.5	
R6	880	700	300	400	69	924	410	423	80	
R6a	986	700	302	400	73	1119	410	423	84	

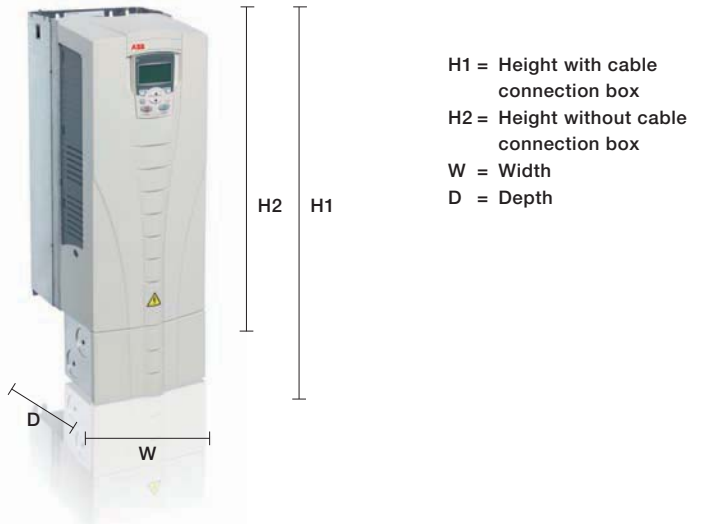

Brake units and choppers technical data

Frequency converter input voltage	Resistor ohm	Continuous output W	Max. output 20 s W	Brake unit type code
200 - 240 V AC	32	2000	4500	ACS-BRK-C
380 - 480 V AC	32	2000	12000	ACS-BRK-C
200 - 240 V AC	10.5	7000	14000	ACS-BRK-D
380 - 480 V AC	10.5	7000	42000	ACS-BRK-D

Chopper dimensions

Width (W) mm	Height (H) mm	Depth (D) mm	Weight kg	Brake unit type code
150	500	347	7.5	ACS-BRK-C
270	600	450	20.5	ACS-BRK-D

Typical control connections

These connections are shown as examples only. Please refer to the ACS550 User's Manual – Installations, for more detailed information.

Available options

- IP54 protection class (frames R1-R6a)
- Assistant control panel is available; see "User interfaces" on page 23
- Door mount kits available for keypad
- Relay output extension, giving three extra relays; see page 23
- Encoder feedback option available
- An extensive range of fieldbus modules is available; see page 23









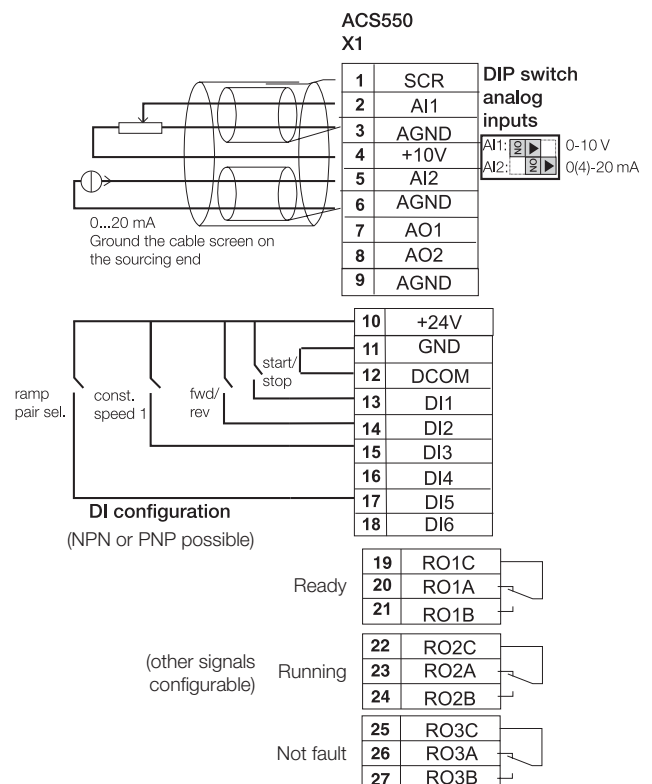

ABB standard drive

ACS550 – User interfaces

Assistant control panel

For easy drive programming, a detachable, multilingual alphanumeric Assistant control panel is offered as standard. The control panel has various assistants and a built-in help function to guide the user. It includes a real time clock, which

Name	Function
	Start Initiates operation of drive
	Stop Ceases operation of drive
	Up Changes parameters and their value/ increases reference
	Down Changes parameters and their value/ decreases reference
	Loc/Rem Changes drive state from local control (control panel) to remote control (I/O or other external source)
	HELP Built-in "Help" button
	Softkey 1 Function changes according to state of panel
	Softkey 2 Function changes according to state of panel

can be used during fault logging and in controlling the drive, such as start/stop at certain times of the day. The control panel can be used for copying parameters for back-up or for downloading to another drive. A large graphical display and soft-keys make it extremely easy to navigate.

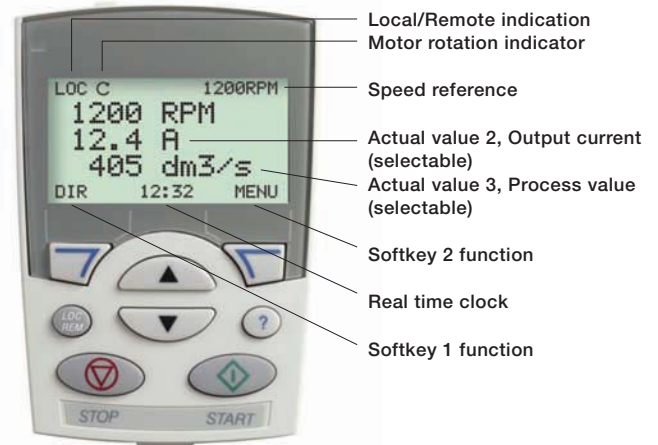

Overview of ACS550 interfaces

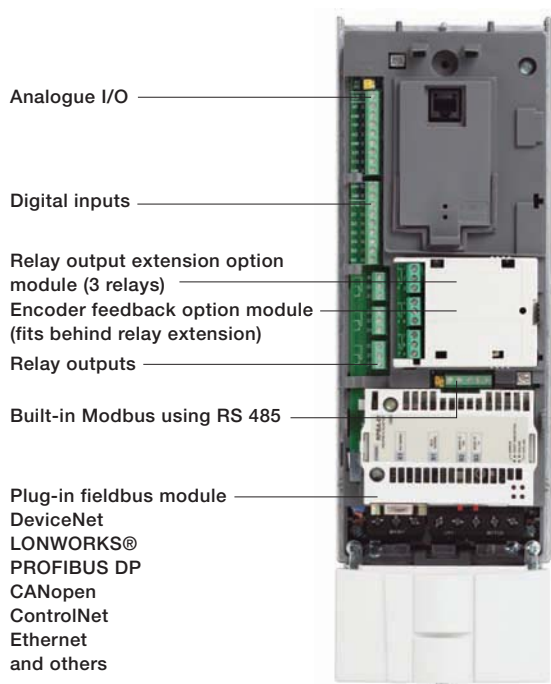

Relay extension

An extra 3 volts free change-over relays can be added to the ACS550 by requesting an MREL module.



Panel mounting kit, IP54 and IP66

The panel mounting kit enables mounting of control panels on cabinet doors. These kits include a 3 m extension cable, a gasket, mounting screws and a mounting template - two versions are now available, IP54 and IP66. The IP66 has an additional keypad membrane cover.



FlashDrop

A powerful palm-sized tool for fast and easy parameter setting, ideal for programming many drives. Programming in the box - unpowered. Ideal for OEMs as programming can be left until the moment before commissioning, or at the end of the production line, making it a safe option.



Fieldbus modules and fieldbus

An extensive range of fieldbus modules are available to allow connection to all the major industrial protocols. The drive has an RS485 Modbus interface built-in.



DriveWindow Light PC tool

DriveWindow Light is a parameterisation and commissioning tool used to set-up and commission the drive. Monitoring and diagnostic facilities are included, as well as a local control panel. Wizards are included to guide the user through the most commonly performed tasks.

ABB standard drives for fans and pumps

0.37 kW to 22 kW, ACS310

Supply voltage 200 – 480 V, 3-phase only

Motor control method – Scalar (quadratic/squared torque only)

What is an ABB standard drive for fans and pumps?

The ABB standard drives family is extended with a new series of dedicated drives designed for squared-torque applications such as pumps, booster pumps and centrifugal fans.

The drive design includes a powerful set of features which benefit pump and fan applications including built-in PID controllers and PFC (pump and fan control). The drives also have pre-programmed protection functions such as pipe cleaning (anti-jam) for preventive maintenance.

These features, combined with pre-programmed application macros, an intuitive user interface and several assistant screens, speed up the installation, parameter setting and commissioning of the drive.

Where can it be used?

The new ABB standard drive's software features are ideal for solving the problems and issues surrounding pumping in general, and those of water and waste water in particular.

OEMs dealing with fans and pumps will find a powerful cost effective package for pumping and fan applications including: booster pumps, submersible pumps, irrigation pumps, centrifugal fans.



For more details, please refer to Technical Catalogue 3AUA0000051082

The drive is also designed to compliment the features offered by the industry specific products for water and waste water.

Highlights – ACS310

- Pump and fan features such as pump and fan control (PFC and SPFC), for multi-pump and soft fill control
- Pipe cleaning (anti-jam) and pipe fill functions
- Energy efficiency counters
- Energy optimiser – optimises the motor control for the application
- Load analyser for optimised dimensioning of the drive, motor and process
- Embedded Modbus RS-485 fieldbus interface
- FlashDrop tool for fast parameter setting, without mains power

Main features

Feature	Advantage	Benefit
Pump and fan control (PFC) feature to control pumps and fans in parallel	One drive controls several pumps or fans and eliminates the need for an external programmable logic controller Interlock function enables one motor to be disengaged from the mains supply while others continue operating in parallel	Saves cost of additional drives and external PLC Longer life for pump or fan system while reducing maintenance time and costs Maintenance can be carried out safely without stopping the process
Soft pump and fan control feature (SPFC)	Reduces unwanted pressure peaks in pumps and pipelines when an auxiliary motor is started	Reduces maintenance costs Longer life for pump or fan system
Pump protection functions	Pre-programmed features like: Pipe cleaning (anti-jamming), inlet/outlet pressure supervision and detection of under or over load for preventive maintenance	Reduces maintenance costs Smoother processes: improved and optimised system Longer life for pump and fan system, reduced maintenance costs
Energy monitoring and optimising features	Drive monitors the saved energy compared to equivalent DOL operation Drive controls the motor voltage dependant on the load	Energy savings presented in local currency and CO ₂ Consumed energy optimised across the speed and load range
Full output current at 50°C ambient	Drive can be operated in ambient temperatures up to 50°C without de-rating the output current	Optimised drive dimensioning for wide temperature range
Unified height and depth	Optimum installation layout, as all drive frames are the same height – only the width changes	Space savings. Easier to lay the cabinet back panel out
Best in class user interfaces	Assistant and Basic keypads with intuitive operation. Short and long menus, Assistants and wizards for ease of use	Users are supported as they program the drive, can tailor the open menu views to suite there customer needs
FlashDrop*	Faster and easier drive set up and commissioning for volume manufacturing	Fast, safe and trouble-free method to set up and commission without powering up the drive - patented
RoHS compliance	Compliance achieved during 2007	Environmentally friendly drives

* For details of FlashDrop, see user interfaces (page 27)

ABB standard drives for fans and pumps

ACS310 – Ratings, types, voltages and prices

3-phase supply voltage 200-240 V

Nominal ratings		Max Output A	Frame	Fuse A Type gG	Heat dissipation W	Cooling requirements m ³ /h	Type	IP20 price without control panel*
Nominal kW	Nom. output current A							
0.37	2.6	4.2	R0	10	42	*Nat Vent	ACS310-03E-02A6-2	£163
0.55	3.9	6.1	R0	10	54	*Nat Vent	ACS310-03E-03A9-2	£171
0.75	5.2	8.2	R1	15	64	24	ACS310-03E-05A2-2	£207
1.1	7.4	11.7	R1	15	86	24	ACS310-03E-07A4-2	£229
1.5	8.3	13.1	R1	15	88	21	ACS310-03E-08A3-2	£265
2.2	10.8	17.2	R2	20	111	21	ACS310-03E-10A8-2	£348
3	14.6	23.3	R2	30	140	52	ACS310-03E-14A6-2	£395
4	19.4	30.8	R2	35	180	52	ACS310-03E-19A4-2	£423
5.5	26.8	42.7	R3	60	285	71	ACS310-03E-26A8-2	£578
7.5	34.1	54.3	R4	80	328	96	ACS310-03E-34A1-2	£769
11	50.8	80.9	R4	100	488	96	ACS310-01E-50A8-2	£1,003

* Ensure enough space around the unit - refer to the User's Manual for details

* Drives require a control panel for parameter alteration

For 50°C ratings contact ABB

3-phase supply voltage 380-480 V

Nominal ratings		Max Output A	Frame	Fuse A Type gG	Heat dissipation W	Cooling requirements m ³ /h	Type	IP20 price without control panel*
Nominal kW	Nom. output current A							
0.37	1.3	2.1	R0	10	35	*Nat Vent	ACS310-03E-01A3-4	£159
0.55	2.1	3.3	R0	10	40	*Nat Vent	ACS310-03E-02A1-4	£167
0.75	2.6	4.2	R1	10	50	13	ACS310-03E-02A6-4	£183
1.1	3.6	5.8	R1	10	60	13	ACS310-03E-03A6-4	£203
1.5	4.5	7.2	R1	15	69	13	ACS310-03E-04A5-4	£265
2.2	6.2	9.8	R1	15	90	19	ACS310-03E-06A2-4	£293
3	8	12.8	R1	20	107	24	ACS310-03E-08A0-4	£377
4	9.7	15.4	R1	25	127	24	ACS310-03E-09A7-4	£428
5.5	13.8	21.9	R3	30	161	52	ACS310-03E-13A8-4	£497
7.5	17.2	27.3	R3	35	204	52	ACS310-03E-17A2-4	£655
11	25.4	40.4	R3	50	301	71	ACS310-03E-25A4-4	£800
15	34.1	54.3	R4	80	408	96	ACS310-03E-34A1-4	£1,027
18.5	41.8	66.5	R4	100	498	96	ACS310-03E-41A8-4	£1,198
22	48.4	77.0	R4	100	588	96	ACS310-01E-45A4-4	£1,464

* Ensure enough space around the unit - refer to the User's Manual for details

* Drives require a control panel for parameter alteration

For 50°C ratings contact ABB

Control panel for ACS310

Control panel	Type	Price
Assistant control panel	ACS-CP-A	£80**
Basic keypad	ACS-CP-C	£21

** Price of control panel only when purchased with drive

Panel mounting kit and user interface descriptions, see page 27

ABB standard drives for fans and pumps

ACS310 – Dimensions, I/O and options

Drive dimensions and weights

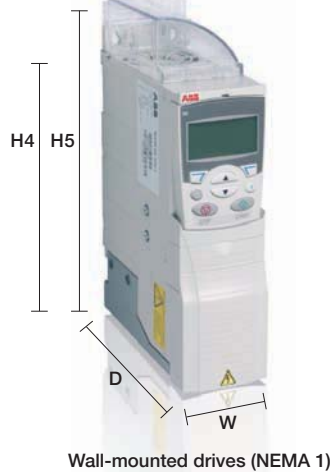
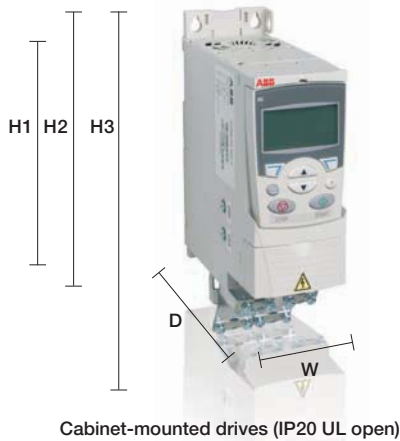

Frame size	IP20 UL Open						NEMA 1/UL Type 1				
	H1 mm	H2 mm	H3 mm	W mm	D mm	Weight Kg	H4 mm	H5 mm	W mm	D mm	Weight kg
R0	169	202	239	70	161	1.1	257	280	70	169	1.5
R1	169	202	239	70	161	1.3	257	280	70	169	1.7
R2	169	202	239	105	165	1.5	257	282	105	169	1.69
R3	169	202	236	169	169	2.9	260	299	169	177	3.5
R4	181	202	244	260	169	4.4	270	320	260	177	5.0

H1 = Height without fastenings and clamping plate
 H2 = Height with fastenings but without clamping plate
 H3 = Height with fastenings and clamping plate
 H4 = Height with fastenings and NEMA 1 connection box
 H5 = Height with fastenings, NEMA 1 connection box and hood
 W = Width
 D = Depth

Options available

- Input and output chokes
- Brake chopper resistors (all drives in the ACS310 range have integral chopper)
- 1st. environment EMC filters - footprint style
- Low leakage EMC filters < 30mA leakage
- FlashDrop
- An extensive range of user interfaces is available - please see following pages

Typical control connections



ABB standard drives for fans and pumps

ACS310 – User interfaces

Assistant control panel

The Assistant control panel features a multilingual alphanumeric display for easy drive programming. The control panel has various assistants and a built-in help function to guide the user. It includes a real time clock, which can be used during fault logging and in controlling the drive, such as start/stop. The control panel can be used for copying parameters for backup or for downloading to another drive. A large graphical display and softkeys make it extremely easy to navigate. For further information, see ABB standard drive section on page 23.

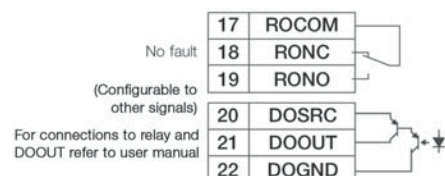
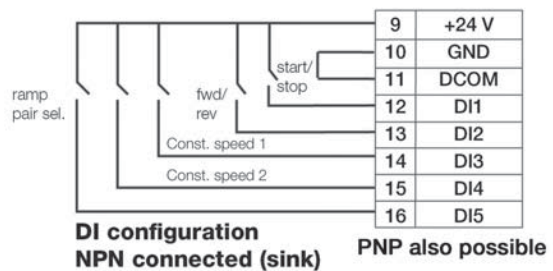
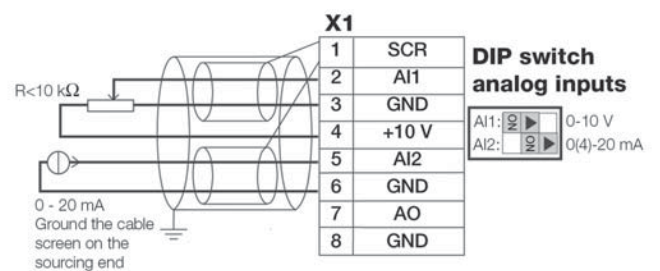

Relay extension module

Add an additional three relays to the ACS310 to allow greater use of the PFC program. Fits behind the keypad.



Potentiometer

Potentiometer with two switches: start/stop and forward/reverse direction. No external power source is needed for the potentiometer.



Basic control panel

The Basic control panel features a single line numeric display. The panel can be used to control the drive, set the parameter values or copy them from one drive to another.



FlashDrop

Programme the drive whilst still in the box, with no power. Perfect for OEMs and machine builders. FlashDrop is a powerful palm sized tool for fast and easy parameter selecting and setting. It gives the possibility to hide selected parameters to protect the machine. The tool stores 20 parameter sets, which can be moved between a PC and a drive. Safe programming during machine building production.



Panel cover

The panel cover protects the drive's connection surfaces. The ABB standard drive is delivered with a panel cover as standard. In addition, there are two alternative control panels available as options, see above.



Fieldbus communications

ACS310 has no industrial fieldbus interfaces, but it does have an RS485 Modbus communications link built-in. This link can be used to communicate to industrial HMI's or remote monitoring devices, or to a fieldbus via a suitable gateway.

NEMA 1 kit

The NEMA 1 kit is a convenient cover which is added to the drive and enables easy wall-mounting. It includes a connection box for finger protection, conduit tube installation and a hood for protection against dirt and dust.



DriveWindow Light PC tool

DriveWindow Light is a parameterisation and commissioning tool used to set-up and commission the drive. Monitoring and diagnostic facilities are included, as well as a local control panel. Wizards are included to guide the user through the most commonly performed tasks.

Panel mounting kit, IP54 and IP66

The panel mounting kit enables mounting of control panels on cabinet doors. These kits include a 3 m extension cable, a gasket, mounting screws and a mounting template - two versions are now available, IP54 and IP66. The IP66 has an additional keypad membrane cover.



ABB industrial drive

0.55 kW to 2,800 kW, ACS800
 Supply voltage 380-690 V (230 V)
 Motor control method: DTC



What is an ABB industrial drive?

ABB industrial drives are highly flexible AC drives that can be customised to meet the precise needs of industrial applications. The drives cover a wide range of powers and voltages, including voltages up to 690 V. ABB industrial drives can be built in a number of differing formats: wall mounted, free standing, cabinet, industrial kits, multidrives or liquid cooled. This section describes the most popular styles. Page 41 describes other variants. Order-based customisation is an integral part of the offering.



Where can it be used?

The ABB industrial drive is equipped with the premium motor control platform, DTC, and as such is ideally suited for the most demanding industrial applications, like high performance centrifuges as well as constant torque applications such as cranes, winders, hoists and heavy conveyors. Applications with high breakaway torque, like rubber mixers and highly precise applications like paper machines and engine dynamometers are easily handled. The drive has ATEX certification with ABB's Ex d, Ex de, Ex nA and Ex tD motors and has marine certification for Lloyds, DNV and ABS.

Highlights

- Blanket ATEX certification (Ex) with ABB's motors
- Specialised software variants for selected applications
- Adaptive programming - like having a PLC inside
- Common user and process interface with fieldbus
- Common software tools for sizing and commissioning
- 6-pulse, 12-pulse, low harmonic, 4Q, air-cooled, water-cooled, flange mounting
- Innovative hardware variants
- DTC (direct torque control) superior motor performance
- Flexibility to programme more advanced applications

Main features

Feature	Advantage	Benefit
Direct torque control	Full torque at zero speed without encoder Accurate speed and torque control	Consistently excellent performance ensures that drive is not the limiting factor in process
Built-to-order	Customer can specify a wide range of options and build variants. Loaded with application specific software	Always meets application needs, tailored for the customer
Adaptive programming	Small PLC inside your drive as standard 15 programmable function blocks. Up to 200 blocks by loading 'multiblock'	Needs no additional hardware Adapt the drive to the specific needs of the project
Dedicated software loading packages	Industry specific software, fully researched, factory written and fully supported	Solve the application with very little effort
Application macros	Popular I/O configurations, pre-written	Fast settings for many applications
Brake choppers	Built into all units (when ordered)	Reduced costs, high performance, internal monitoring No additional space or installation time needed
Low peak volts and du/dt	Motor peak voltage and rate of rise meets IEC60034-17	Kind to motor windings
Compact size	Contains EMC filter and chokes inside the drive	No extra space or cabling is needed
Cooling fan	Silent long-lifetime cooling fan that switches on and off	Reduced maintenance, time and running costs
EMC	2nd environment RFI filters as standard 1st environment optional	No need for additional external filtering, additional space, or additional cabling between drives and filter
Fieldbus gateway	Snap-on module that is easily mounted inside drive	Wide range of gateways means choice of automation system becomes independent of drive manufacturer
I/O	Extensive and flexible standard and expansion I/O provides additional analogue or digital connections	No need for additional space or cabling
Start-up assistant	Guides user through all essential settings without going to parameter list	Easy set-up of parameters, your own language, on-line info system always available
Huge range of hardware variants	Special variants for wall, cabinet mount, 4Q, low harmonic, pre-built cabinets, drive kits, water-cooled	There is always an ABB industrial drive variant that fits the specification and requirements
Liquid cooled drives	Most compact fully enclosed drive on the market Fully certified for marine use	Low losses to control room, low noise, totally enclosed for harsh environments

ABB industrial drive

ACS800 – Variants, ratings voltages and prices



Wall-mounted single drives

Series ACS800-01

- 0.55 to 160 kW, (230 - 690 V)
- 55% size reduction at 160 kW
- IP21 as standard, IP55 as option
- Wide range of built-in options
- Optional cable box for SWA cables
- Coated boards and internal I/O options
- Built-in brake chopper
- EMC filter for 1st environment, restricted distribution according to EN 61800-3 - optional
- EMC filter for 2nd environment, unrestricted distribution according to EN 61800-3 - standard
- Internal fieldbus options
- ACS800-01 is type tested for marine applications
- Blanket certification with ABB ATEX motors



For further information, see Technical Catalogue 3AFE 68375126 EN

Three phase supply voltage 380, 400 or 415 V. The power ratings are valid at nominal voltage (400 V)

No-overload use		Light overload		Heavy-duty use		Max output	Frame	Fuse A	Heat dissipation	Cooling requirements	Type	IP21 Price with keypad	IP55 Price with keypad
$P_{cont. max}$ kW	$I_{cont. max}$ A	P_N kW	I_N A	P_{hd} A	I_{hd} A	A		†Type gG	W	m ³ /h			
1.5	5.1	1.5	4.7	1.1	3.4	6.5	R2	10	100	35	ACS800-01-0003-3	£988	£1,143
2.2	6.5	2.2	5.9	1.5	4.3	8.2	R2	10	120	35	ACS800-01-0004-3	£1,028	£1,183
3	8.5	3	7.7	2.2	5.7	10.8	R2	10	140	35	ACS800-01-0005-3	£1,098	£1,253
4	10.9	4	10.2	3	7.5	13.8	R2	16	160	35	ACS800-01-0006-3	£1,248	£1,403
5.5	13.9	5.5	12.7	4	9.3	17.6	R2	16	200	35	ACS800-01-0009-3	£1,378	£1,533
7.5	19	7.5	18	5.5	14	24	R3	20	250	69	ACS800-01-0011-3	£1,540	£1,748
11	25	11	24	7.5	19	32	R3	25	340	69	ACS800-01-0016-3	£1,770	£1,978
15	34	15	31	11	23	46	R3	40	440	69	ACS800-01-0020-3	£2,060	£2,268
22	44	18.5	41	15	32	62	R4	50	530	103	ACS800-01-0025-3	£2,449	£2,725
30	55	22	50	18.5	37	72	R4	63	610	103	ACS800-01-0030-3	£2,799	£3,075
37	72	30	69	22	49	86	R5	80	810	250	ACS800-01-0040-3	£3,059	£3,355
45	86	37	80	30	60	112	R5	100	990	250	ACS800-01-0050-3	£3,699	£3,995
55	103	45	94	37	69	138	R5	125	1190	250	ACS800-01-0060-3	£4,349	£4,645
75	145	75	141	45	100	170	R5	160	1440	405	ACS800-01-0075-3	£4,669	£4,965
90	166	75	155	55	115	202	R6	200	1940	405	ACS800-01-0100-3	£5,921	£6,404
110	202	90	184	75	141	282	R6	224	2310	405	ACS800-01-0120-3	£7,011	£7,494
110	225	110	220	90	163	326	R6	250	2810	405	ACS800-01-0135-3	£7,132	£7,615
132	260	132	254	110	215	326	R6	315	3260	405	ACS800-01-0165-3	£8,741	£9,224
160	290	160	285	132	234	351	R6a	315	4200	405	ACS800-01-0205-3	£10,316	£10,799

† For fuse selection, refer to the hardware manual, weak networks may require aR fuses

Other ratings and voltages are available, 230 V, 500 V, 690 V. Price on application. Includes 2nd environment EMC filter and control panel

ABB industrial drive

ACS800-01 – Dimensions and options



Dimensions and weights

Frame size	IP21					IP55			
	H1 mm	H2 mm	W1 mm	Depth mm	Weight kg	H mm	W mm	Depth mm	Weight kg
R2	405	370 ¹⁾	165	226	9	528	263	241	16
R3	471	420 ¹⁾	173	265	14	528	263	273	18
R4	607	490 ¹⁾	240	274	26	774	377	278	33
R5	739	602 ¹⁾	265	286	34	775	377	308	51
R6, R6a*	880*	700 ¹⁾	300	399	67*	923	420	420	77

H1 = Height with cable connection box

H2 = Height without cable connection box

* R6a: In -0205-3, H1 is 977 mm and weight is 70 kg

¹⁾ ACS800-01 without cable connection box does not fulfil IP21 requirements



Options for ACS800-01

ACS800-01 is a wall mounted drive, so the options fit inside

- IP55 variant
- UK gland box to accommodate SWA cable
- Different levels of EMC compliance
- SIL2 Safe Torque-Off interface (unit mounts outside the drive)
- Coated boards
- Extended warranty

All ACS800s use the same common options and user interfaces, these are detailed on page 36

- The drive has two slots for I/O and fieldbus expansion and one optical interface slot (an additional mother board can also be added – giving three more slots)
- I/O modules can be chosen from analogue expansion, digital expansion, encoder and resolver feedback options
- Fieldbus modules are always fixed to slot 1, and all of the major industrial fieldbus modules are available
- The drive can also be ordered with specially designed application specific software variants. There are 17 variants available. For example, crane, master-follower, winder control, etc. The advantage of selecting these pre-written software variants, is that they have been written to cover the market requirements, they are tested and certified by the factory and come complete with a user manual and cabling instructions.

User Interfaces

Please refer to page 36 for details of the ACS800 common user interfaces.

ABB industrial drive

ACS800 – Variants, ratings, types and prices



Chassis-mounted single drive

Series ACS800-04 and ACS800-04M

- Specifically designed for system integration
- 0.55 to 1,900 kW (230 V - 690 V)
- IP00 kits or IP20 modules depending on frame size
- R1-R6 frames are back sheet mounted; R7 and R8 stands on cabinet floor; R8i wheels into the cabinet
- Easy access to power terminals: plug connections on wheeled D4 and R8i units
- Side-by-side mounting (excl. versions with side exit)
- Extensive, programmable I/O with galvanically isolated inputs
- Three I/O and fieldbus extension slots inside
- ACS800-04M can be ordered as disassembled kit of parts to optimise the items purchased
- Rittal assembly kits available for easy cabinet integration
- Service 'skateboard' for R7, R8 frames

The R7 and R8 modules are detailed below, please contact ABB for information on the other frame sizes shown here.



For further information, see Technical Catalogue 3AFE68404592

Three phase supply voltage 380, 400 or 415 V. The power ratings are valid at nominal voltage (400 V)

No-overload use		Light overload		Heavy-duty use		Max output	Frame	Fuse A	Heat dissipation W	Cooling requirements m³/h	Type	IP00 Price with keypad*
P _{cont. max} kW	I _{cont. max} A	P _N kW	I _N A	P _{hd} kW	I _{hd} A	A		†Type gG				
110	206	110	202	90	163	326	R7	250	3000	540	ACS800-04-0140-3	£6,447
132	248	132	243	110	202	404	R7	315	3650	540	ACS800-04-0170-3	£7,827
160	289	160	284	132	240	432	R7	315	4300	540	ACS800-04-0210-3	£9,227
200	445	200	440	160	340	588	R8	500	6600	1220	ACS800-04-0260-3	£10,953
250	521	250	516	200	370	588	R8	630	7150	1220	ACS800-04-0320-3	£12,653
315	602	315	590	250	477	840	R8	630	8100	1220	ACS800-04-0400-3	£14,383
355	693	355	679	315	590	1017	R8	800	8650	1220	ACS800-04-0440-3	£16,313
400	720	400	704	355	635	1017	R8	800	9100	1220	ACS800-04-0490-3	£18,583

Other ratings and voltages available on application, 230V, 500V, 690V
Drive can be purchased pre-assembled or as a disassembled kit, where parts can be omitted for cost optimisation by panel builders (R7, R8 frames)

Includes 2nd environment EMC filter, control panel and door mounting kit
Multiple control panel mounting options - please ask.
* Comes with keypad and a door mount kit (+J400, +J410)
† For fuse selection, refer to the hardware manual, weak networks may require aR fuses

Dimensions and weights

Frame size	Bookshelf mounting			Flat-type mounting			Weight kg
	H mm	W mm	D mm	W mm	H kg	D mm	
R7	1121	427*	473	100	1152	632	100
R8	1564	562*	568	205	1596	779	205

* R7 module 250mm wide, R8 module 350mm wide

Options for ACS800-04

When purchased as an ACS800-04, the kit always contains pedestal, busbars, power module, control module and keypad. If purchased as an ACS800-04(M) then it is possible to tailor the offering, remove busbars, have left or right handed or flat or bookcase orientation.



User Interfaces

Please refer to page 36 for details of the ACS800 common user interfaces.

ABB industrial drive

ACS800 – Variants, ratings, types and prices



Cabinet-built drives

Series ACS800-07

- 45 to 2,800 kW, (380 - 690 V)
- IP21 as standard, IP22, IP42, IP54 and IP54R as options
- Up to 500 kW based on a single module including rectifier and inverter
- Above 500 kW separate rectifier and inverter modules that have plug-in power connectors for easy maintenance and redundancy. Modules wheel in and out of cabinet
- 6 or 12 pulse operation as standard
- Extremely compact, internal swinging gate for control options
- Factory-built cabinet with EMC and thermally type-tested for trouble-free operation
- Extensive range of standard options
- ATEX approved PTC interfaces and blanket certification with ABB motors
- TÜV approved emergency stopping options



For further information, see Technical Catalogue 3AFE68375126

The ACS800-07 cabinet drive range covers an extensive power and options range. The drives shown in the table are for the basic IP21 build format; and only up to 400 kW. Please contact ABB to discuss the exact requirements of your factory built and certified cabinet, to ensure all relevant options are catered for.

Watercooling

ACS800-07 can also be supplied in a liquid cooled format, ACS800-07LC, please refer to page 43 for details.

Three phase supply voltage 380, 400 or 415 V. The power ratings are valid at nominal voltage (400 V)

No-overload use		Light overload		Heavy-duty use		Max output	Frame	Fuse A	Heat dissipation	Cooling requirements	Type	Price
$P_{cont. max}$	$I_{cont. max}$	P_N	I_N	P_{hd}	I_{hd}	A		† Type gG	W	m ³ /h		
kW	A	kW	A	kW	A							
75	145	75	141	45	100	170	R5	315	1440	405	ACS800-07-0075-3	Price on application
90	166	75	155	55	115	202	R6	200	1940	405	ACS800-07-0100-3	
110	202	90	184	75	141	282	R6	224	2310	405	ACS800-07-0120-3	
110	214	110	220	90	163	326	R6	250	2570	405	ACS800-07-0135-3	
132	260	132	254	110	215	326	R6	550	3260	405	ACS800-07-0165-3	
160	290	160	285	132	234	351	R6	550	4200	405	ACS800-07-0205-3	
200	445	200	440	160	340	588	R8	500	6600	1220	ACS800-07-0260-3	
250	521	250	516	200	370	588	R8	630	7150	1220	ACS800-07-0320-3	
315	602	315	590	250	477	840	R8	630	8100	1220	ACS800-07-0400-3	
355	693	355	679	315	590	1017	R8	800	8650	1220	ACS800-07-0440-3	
400	720	400	704	355	635	1017	R8	800	9000	1220	ACS800-07-0490-3	

Other ratings and voltage ranges available, 230 V, 500 V, 690 V.

Price on application

Includes 2nd environment EMC filter and control panel

† For fuse selection, refer to the hardware manual, weak networks may require aR fuses

ABB industrial drive

ACS800-07 – Dimensions and options



Dimensions and weights, cabinet built

Frame size	*Width with fuse switch	Height IP 21/22/42	Height IP54	Depth	*Depth top entry/exit	Weight (kg) with line fuse switch
R5/R6	430	2130	2315	645	646	300
R8	830	2130	2315	646	646	500

ACS800-07 can be supplied with an extensive range of standard cabinet options, contact your ABB representative for details
 *some of these options alter the cabinet dimensions
 Higher power standard and bespoke cabinets can be quoted on request

Options for ACS800-07

ACS800-07 is a cabinet drive, so its options fit inside the cabinet. The cabinet drive can be fitted with:

- IP21, 22, 42, 54, 54R variants (no IP55)
- Emergency stop variants, TÜV approved
- Motor thermistor relays
- ATEX-approved motor protection
- Marine construction
- UL approved components
- Various types of cable markings, cabinet heaters, door furniture and lighting etc.
- Sine filter fitted to output (for older motors)
- Top or bottom cable entry for either motor or power cables
- UK gland plates for SWA cables
- 110V control inside the cabinet
- Different levels of EMC compliance
- Extended warranty
- Additionally, ABB can accommodate any specialised option or feature, by using its in-house application design team

ACS800-07 also comes with options that are fitted to the drive module which is inside the cabinet:

- SIL2 Safe Torque-Off interface
- Coated boards



User Interfaces

All ACS800s use the same common options and user interfaces, these are detailed on page 36

- The drive has two slots for I/O and fieldbus expansion and one slot for an optical interface (an additional mother board can also be added – giving three more slots)
- I/O modules can be chosen from analogue expansion, digital expansion, encoder and resolver feedback options
- Fieldbus modules are always fixed to slot 1, and all of the major industrial fieldbus modules are available
- The drive can also be ordered with specially designed application specific software variants. There are 11 variants available. For example, crane, master follower, winder control, etc. The advantage of selecting these pre-written software variants is that they have been written to cover the market requirements; they are tested and certified by the factory; and come complete with a User Manual and cabling instructions.

ABB industrial drive

ACS800 – Variants, ratings, voltages and prices



Low harmonic, active rectifier drives

Wall-mounted and cabinet-built

A dedicated range of low harmonic drives based on active rectifier technology. No regenerative capability ensures no mistakes on generator supplies, still retaining a low 2-4% THD harmonic signature.

Series ACS800-31, wall-mounted

- 7.5 to 110 kW (230 - 690 V)
- IP21 as standard
- Single package for easy cabinet installation, reducing installation time and cabinet space

Series ACS800-37, cabinet-built

- Power range from 75 to 2500 kW (230 to 690 V)
- IP21 as standard; IP22, IP42, IP54 and IP54 R available as options
- Wheel-out power modules for improved manual handling
- Plug-in power connectors for easy maintenance and redundancy
- Power module redundancy for improved availability
- Factory-built cabinets ensure good installation



For further information, see Technical Catalogue 3AFE68375126

The R5 and R6 modules are detailed below. Please contact ABB if you require more power. Also, fully regenerative products are available called ACS800-11 and ACS800-17. Please refer to page 41 for more information.

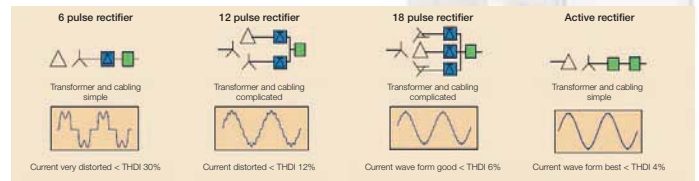

Alternatives in reducing line harmonics

Low harmonic, wall-mounted drives - ACS800-31

Three phase supply voltage 380, 400 or 415 V. The power ratings are valid at nominal voltage (400 V)

No-overload use		Light overload		Heavy-duty use		Max output A	Frame	Fuse A †Type gG	Heat dissipation W	Cooling requirements m³/h	Type	IP21 Price with keypad
P _{cont. max} kW	I _{cont. max} A	P _N kW	I _N A	P _{hd} kW	I _{hd} A							
15	34	15	32	11	26	52	R5	40	550	350	ACS800-31-0016-3	£3,732
18.5	38	18.5	36	15	34	61	R5	40	655	350	ACS800-31-0020-3	£4,182
22	47	22	45	18.5	38	68	R5	50	760	350	ACS800-31-0025-3	£4,752
30	59	30	56	22	45	90	R5	63	1000	350	ACS800-31-0030-3	£5,447
37	72	37	69	30	59	118	R5	80	1210	350	ACS800-31-0040-3	£6,417
45	86	45	83	30	65	137	R5	100	1450	350	ACS800-31-0050-3	£7,617
55	120	55	114	45	88	168	R6	125	1750	405	ACS800-31-0060-3	£8,729
75	150	75	143	55	117	234	R6	160	2350	405	ACS800-31-0070-3	£10,149
90	165	75	157	75	132	264	R6	200	2800	405	ACS800-31-00100-3	£11,659

Other ratings and voltage ranges available, 230 V, 500 V, 690 V. Price on application.

Includes 2nd environment EMC filter and control panel

Prices for low harmonic cabinet drives ACS800-37 also available on application

† For fuse selection, refer to the hardware manual, weak networks may require aR fuses

ABB industrial drive

ACS800-31 – Dimensions and options and ACS800-37 options



Dimensions and weights, ACS800-31

Frame size	Height mm	Width mm	Depth mm	Weight kg
R5	816	265	390	62
R6	970	300	440	100

Height includes cable box, one enclosure, no external items

Options for ACS800-31

ACS800-31 is a wall-mounted drive, so the options fit inside

- IP55 variant
- UK gland box to accommodate SWA cable
- Different levels of EMC compliance
- SIL2 Safe Torque-Off interface (unit mounts outside the drive)
- Coated boards standard
- Extended warranty

Options for ACS800-37

ACS800-37 is a cabinet drive, so all of the options available for ACS800-31 are also valid, as they fit inside the cabinet.

Additionally the cabinet drive can be fitted with:

- IP21, 22, 42, 54, 54R variants (no IP55)
- Emergency stop variants
- Motor thermistor relays
- ATEX-approved motor protection
- Marine construction
- UL approved components
- Various types of cable markings, cabinet heaters, door furniture and lighting etc.
- Sine filter fitted to output (for older motors)
- Top or bottom cable entry for either motor or power cables
- UK gland plates for SWA cables
- 110V control inside the cabinet
- Additionally, ABB can accommodate any specialised option or feature, by using its in-house application design team

ACS800-37 also comes with options that are fitted to the drive module which is inside the cabinet

- SIL2 Safe Torque-Off interface
- Coated boards



User Interfaces

All ACS800s use the same common options and user interfaces, these are detailed on page 36

- The drive has two slots for I/O and fieldbus expansion and one slot for an optical interface (an additional mother board can also be added – giving three more slots)
- I/O modules can be chosen from analogue expansion, digital expansion, encoder and resolver feedback options
- Fieldbus modules are always fixed to slot one, and all of the major industrial fieldbus modules are available
- The drive can also be ordered with specially designed application specific software variants. There are 11 variants available in all. For example, crane, master follower, winder control, etc. The advantage of selecting these pre-written software variants is that they have been written to cover the market requirements. They are tested and certified by the factory and come complete with a User Manual and cabling instructions.

ABB industrial drive

ACS800 – Common user interfaces



Control panel

The control panel features a full-text multilingual display. Dedicated keys allow fast access to actual signals, parameters, assistant functions and drive information. The panel can be used for parameter copying and for configuring adaptive programmes, working as a PLC inside the drive. Local motor control is also possible.



Panel mounting kits

Kits are available that allow mounting on the cabinet door, or in a holder inside the cabinet. The panel can also simply be screwed to the cabinet door.



Fieldbus

The ACS800 supports an extensive list of fieldbus modules for connectivity to industrial networks.



I/O expansion

ACS800 can be fitted with a large range of analogue and digital I/O modules to expand its I/O capability.



DriveWindow - PC Tool

DriveWindow is a high spec, high speed commissioning, maintenance and monitoring tool for the ACS800 drive range. It operates over an optical fibre link. (Drive requires an RCDO module)

Drive AP - PC Tool

Drive AP allows access to the ACS800 adaptive, block programming environment.

Typical I/O and control connections

The ABB industrial drive family uses the same control card, keypad and software structure throughout its entire range. Analogue and digital I/O channels are used for different functions such as control, monitoring and measurement purposes (e.g. motor temperature). In addition, optional I/O extension modules are available providing additional analogue or digital I/O connections.

Below are the standard drive control I/O of the ABB industrial drive with factory macro. For other ACS800 application macros the functions may be different. Please refer to the firmware manual for details.



ABB industrial drives for water and waste water

1.1 kW to 400 kW, ACQ810
 Supply voltage 380 to 480 V, 3 phase
 Motor control method – DTC

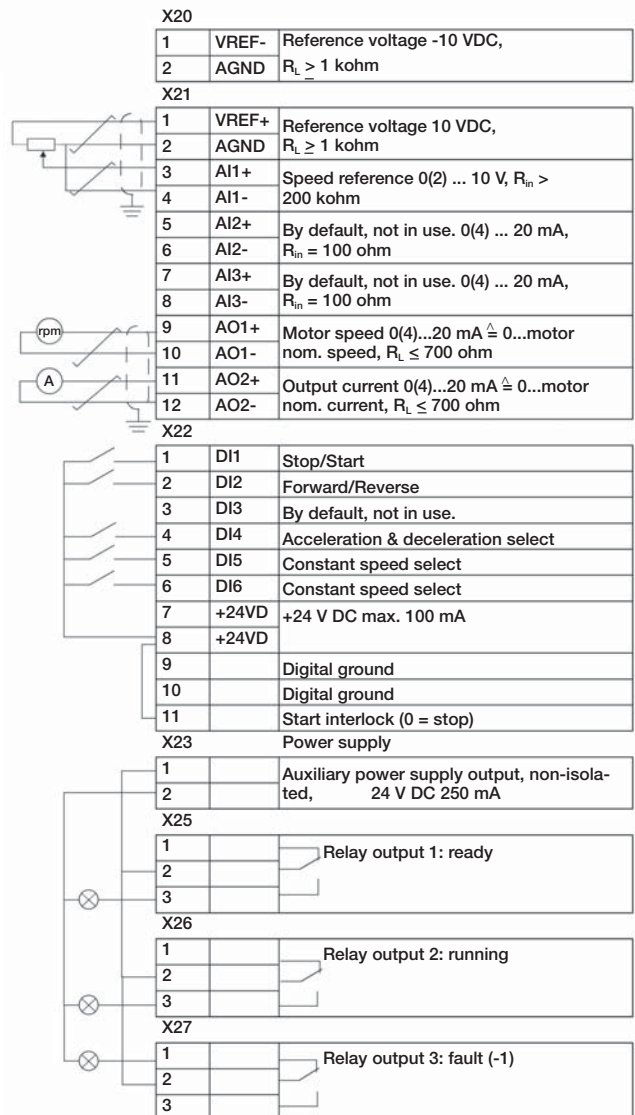

What is an ABB industrial drive for water and waste water?

The ABB industrial drives family is extended with a new series of dedicated drives designed for all of the applications commonly used in the water and waste water industry. Following on from ABB's highly successful IPC (Intelligent Pump Control) software, a brand new module product containing enhanced IPC features has been created, specifically for this sector. Specifically designed modules for water and waste water applications feature tailor-made pump control functions for single and multi-pump systems. These functions ensure smooth, disturbance-free operation of water and waste water processes, maximising energy efficiency while reducing unnecessary downtime. The drives' pump-specific functions decrease the lifecycle cost of the pumping system, helping to save time and money.



For further information, see Technical Catalogue 3AUA0000055685

Where can it be used?

The new ABB industrial drive module can be used for most of the variable speed applications contained within the water and waste water industry, to optimise the system and to save energy. The modules are designed for cabinet assembly and are easily mounted side-by-side. Intelligent start-up assistants ensure that drive commissioning is straightforward. The functions needed for most pumping systems can be easily implemented with the pre-programmed macros. Starting up a pumping system and optimising its performance is extremely easy.

Highlights – ACQ810

- Optimal pump control for various applications
- Intelligent solution for controlling pump performance
- Easy and cost-effective cabinet assembly
- Rapid and simple pumping system start-up
- Advanced energy efficiency in pumping systems
- Maximised process uptime
- Lifecycle support
- Remote monitoring and diagnostics
- Pump auto change

Main features

Feature	Advantage	Benefit
Direct torque control	Premium motor control platform	Lower losses, improved energy saving
Soft pipe filling	Provides a pump with a smooth build-up of flow in pipes	This avoids pressure peaks, and reduces the stresses on weak or ageing water mains, when demand changes
Pump cleaning or anti-jam	Used in waste water pumping stations to prevent pump and pipe clogging and expensive maintenance activities	The function can be set to trigger against different commands e.g on each pump start; on monitoring if the pump is becoming blocked; in response to a digital input or PLC command. If the pump cleaning function runs too often, an alarm is raised
Level control	Used to effectively control the filling or emptying of water or waste water storage tanks	Fast-ramp starting creates a flush effect to keep pipes clear. Users can define the "efficiency speed" based on the pumps best efficiency point
Multi-pump control	Optimal control of applications where several parallel pumps are operated together and the required flow rate is variable	Maintains stable process conditions optimising the speed and number of the pumps needed
Pump priority	Optimal control of applications where the consumption rate varies based on demand	Operate higher capacity pumps during daytime and smaller units at night. This allows pumps to be operated closer to their best efficiency point
Flow calculation	The drive has a flow meter routine that very accurately determines the flow rate within a process	Avoids the need for costly external flow meters and is suitable for applications where the flow data is not needed for invoicing purposes
Pump specific protection features	The protection functions indicate if the pre-defined process conditions change	Underload and overload functions are pre-defined across the speed range at five distinct points. Belt breaks or dry sumps can be detected
Safe Torque-Off	TÜV certified safely to SIL3	Remove contactor from MCC

ABB industrial drives for water and waste water

ACQ810 – Variants, ratings and prices



ACQ810 variants

The ACQ810 is available in several frame sizes to optimise the packing density of the drive. This optimised packing density ensures that MCC cabinet line-ups are as compact as possible. Minimised MCC line-ups mean that compliant bids to the water industry are as small as possible whilst still complying with EMC and thermal requirements.

Frame A and B – EMC external but plug-in, so no extra cabling required.

Frame C to E – EMC and harmonics choke built into the unit, so most compact size with no extra items to fit or cable.

The frame E module is capable of delivering 160 kW in a single back-sheet mountable IP20 unit, the highest power density on the market.

Frame G – This popular modular design has a high power density in a module which is mounted onto a pedestal (which



can be left or right handed, or can be rotated by 90 degrees to a “flat” mount format), so once the heavy cables are connected, there is no need to disconnect them, even if the module needs to be removed.

3 – phase supply voltage 380 – 480V)

Light overload		No overload use	Max output	Frame	Fuses	Heat dissipation	Cooling requirements	Type	Panel mounting kit	IP20 Price
P_N kW	I_{2N} A	$I_{cont. max}$ A	A		A †Type gG	W	m ³ /h			
1.1	2.7	3	4.4	A	6	100	24	ACQ810-04-02A7-4	+J410	
UL	3	3.6	5.3	A	6	106	24	ACQ810-04-03A0-4	+J410	
1.5	3.5	4.8	7	A	10	126	24	ACQ810-04-03A5-4	+J410	
2.2	4.9	6	8.8	A	10	148	24	ACQ810-04-04A9-4	+J410	
3	6.3	8	10.5	A	16	172	24	ACQ810-04-06A3-4	+J410	
4	8.3	10.5	13.5	B	16	212	48	ACQ810-04-08A3-4	+J410	To ensure ABB can tailor the drive to your needs, price on application
5.5	11	14	16.5	B	20	250	48	ACQ810-04-11A0-4	+J410	
7.5	14.4	18	21	B	25	318	48	ACQ810-04-14A4-4	+J410	
11	21	25	33	C	25	375	142	ACQ810-04-021A-4	+J410	
15	28	30	36	C	32	375	142	ACQ810-04-028A-4	+J410	
18.5	35	44	53	C	50	541	200	ACQ810-04-035A-4	+J410	
22	40	50	66	C	50	646	200	ACQ810-04-040A-4	+J410	
30	53	61	78	D	63	840	290	ACQ810-04-053A-4	+J410	
37	67	78	100	D	80	1020	290	ACQ810-04-067A-4	+J410	
45	80	94	124	D	100	1200	290	ACQ810-04-080A-4	+J410	
55	98	103	138	EO	125	1190	168	ACQ810-04-098A-4	+J410	
75	138	144	170	EO	160	1440	405	ACQ810-04-138A-4	+J410	
90	162	202	282	E	250	2310	405	ACQ810-04-162A-4	+J410	
110	203	225	326	E	250	2810	405	ACQ810-04-203A-4	+J410	
132	240	260	326	E	315	3260	405	ACQ810-04-240A-4	+J410	
160	286	290	348	E	315	4200	405	ACQ810-04-286A-4	+J410	
UL	302	340	480	G	500	5000	1220	ACQ810-04-302A-4	+J410	
UL	361	400	568	G	500	6000	1220	ACQ810-04-361A-4	+J410	
200	414	430	588	G	500	6850	1220	ACQ810-04-414A-4	+J410	
250	477	521	588	G	630	7800	1220	ACQ810-04-477A-4	+J410	
315	550	602	840	G	630	8100	1220	ACQ810-04-550A-4	+J410	
355	616	693	1017	G	800	9100	1220	ACQ810-04-616A-4	+J410	
400	704	720	1017	G	800	9700	1220	ACQ810-04-700A-4	+J410	

I_{2N} - Nominal output current. 110% overload 1 min / 5 min. I_{cont} - Continuous rms output current with no overload capacity

UL = UL - NEMA rated motor - no IEC motor equivalent, however the current rating may be useful

† For fuse selection, refer to the hardware manual, weak networks may require aR fuses

ABB industrial drives for water and waste water

ACQ810 – Dimensions, I/O and options



Dimensions and weights

Frame size	Height ¹⁾ mm	Depth ²⁾ mm	Width mm	Weight kg
A	364 (518)	219	94	3.3
B	380 (542)	297	101	5.4
C	567	298	166	15.6
D	567	298	221	21.3
E0	602	376	276	34
E	700	465	312	67
G	1564	571	562	200



Notes

All dimensions and weights are without options

¹⁾ Height is the maximum measure without clamping plates. In A and B frames the external C3 EMC-filter (height with filter in brackets). The EMC filter does not have to be plugged in, it can be sited nearby. EMC-filter is internal in frames C, D, E0 and G

²⁾ Total depth with control panel, 10mm less width

Typical I/O connections

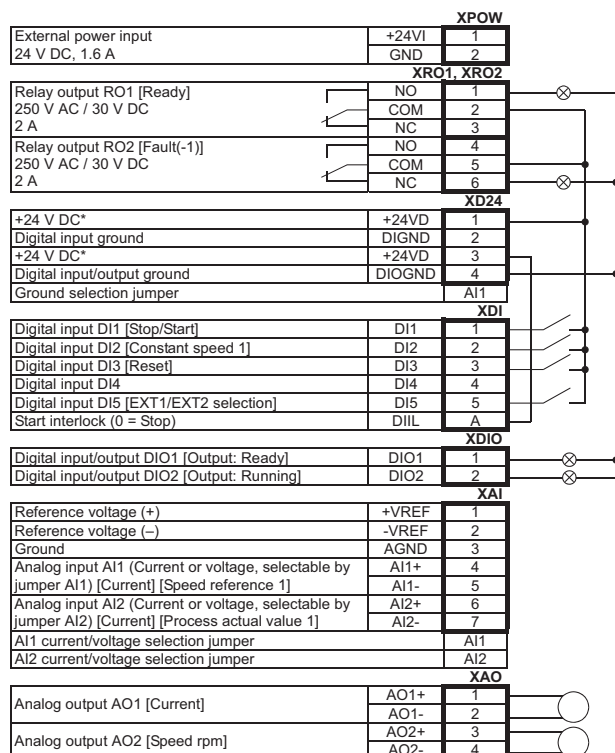

Options

A number of control panel mounting options are available, to optimise MCC design. The drive is normally delivered with a control panel and holder fitted as standard. Other options include:

- No control panel at all
- Control panel door mounting kit
- No cover at all for the drive unit

Other options for the ACQ810 include:

- Analogue I/O extension module
- Analogue and digital extension module
- Relay I/O extension module
- Extensive range of plug-in fieldbus modules
- External du/dt filters if required

Typical STO and Drive to Drive link connections

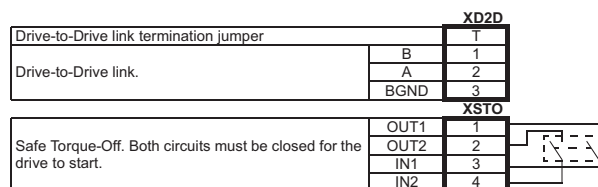

STO stands for Safe Torque-Off, and is certified by TÜV to SIL3 to IEC61508.

STO can be used to guarantee no mechanical rotation (no torque) at the shaft of the motor, and thus allows MCC panels to be built without the need for the traditional contactor, where maintenance of the rotating machinery is a requirement. Electrical isolation will only be required for working on the drive or the electrical connections of the motor, so the traditional door isolator will suffice for that requirement.



ABB industrial drives for water and waste water

ACQ810 – User interfaces

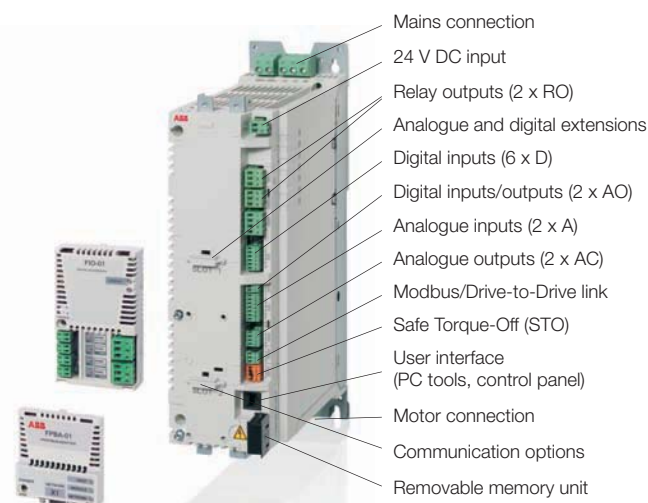

Assistant keypad

For easy drive programming, a detachable, multi-lingual alphanumeric Assistant control panel is preferred as standard. The control panel has various assistants and a built-in help function to guide the user. It includes a real-time clock, which

can be used during fault logging and in controlling the drive, such as start/stop. The control panel can be used for copying parameters for back-up or for downloading to another drive. A large graphical display and softkeys make it extremely easy to navigate.

	Name	Function
	Start	Initiates operation of drive
	Stop	Ceases operation of drive
	Up	Changes parameters and their value/ increases reference
	Down	Changes parameters and their value/ decreases reference
	Loc/Rem	Changes drive state from local control (control panel) to remote control (I/O or other external source)
	HELP	Built-in "Help" button
	Softkey 1	Function changes according to state of panel
	Softkey 2	Function changes according to state of panel

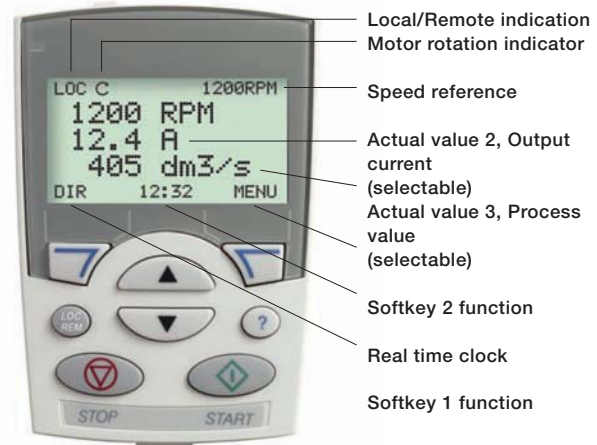

Keypad door mounting platform

Designed to hold the keypad so that it can be attached to the MCC door. An IP54 variant is also available for higher IP requirements



Fieldbus interfaces

Extensive range of plug-in fieldbus interfaces, allowing connection to Profibus, DeviceNet, CanOpen, Modbus RTU and Ethernet.



Removable memory unit

The memory unit stores the complete parameter and firmware set for the drive. Should a drive need to be replaced, swapping the memory unit to the new drive will transfer a complete drive set-up – absolutely no recommissioning is required. This reduces down time in the event of a problem.



DriveStudio PC tool

DriveStudio is a parameterisation and commissioning tool used to set-up and commission the water and waste water drive. Monitoring and diagnostic facilities are included, as well as a local control panel. Wizards are included to guide the user through the most commonly performed tasks.

Expansion for analogue and digital I/O

Additional I/O can be added to the ACQ810. This I/O can be addressed by the fieldbus so that the ACQ810 can be used as an I/O "nest", or of course the I/O can be used to simply allow more connectivity from the process to the drive, for example, flow or level transducers.



DriveSPC PC tool

DriveSPC (Solution Program Composer) allows access to the extended programming area of the ACQ810. Application specific IEC61131 solution programs can be generated and stored inside the drive. This way the drive can be tailored to the application and fully utilise the extended I/O.

EMC filters – frames A and B

Pluggable EMC filters for frame sizes A and B can be plugged directly into the drive, or can be mounted next to the drive on the end of a plug and socket cable – easy to install and mount.



Other ABB drives



ABB industrial drives - free standing

Series ACS800-02

- 45 to 560 kW, (230 - 690 V)
- IP21 standard
- Extremely compact, can be mounted in two orientations, bookshelf or flat-mounting options
- EMC and brake chopper built-in
- Three I/O and fieldbus extension slots inside
- Innovative pedestal enclosure for ease of cabling - pedestal can be supplied in advance
- Drive module on wheels
- Can be provided with an enclosure extension with additional options and local isolation
- Long lifetime cooling fan and capacitors
- Large power terminals allowing the use of a wide range of cable sizes
- ATEX approved PTC interfaces and blanket certification with ABB motors



For further information, see Technical Catalogue 3AFE 68375126 EN

Regenerative, active rectifier drives

Series ACS 800-11, wall-mounted

- Power range 7.5 to 110 kW (230 - 690 V)
- IP21 as standard
- Active rectifier unit
- Single package for easy cabinet installation, reducing installation time and cabinet space

Series ACS800-17, cabinet-built

- Power range 75 to 2,500 kW (230 - 690 V)
- IP21 as standard; IP22, IP42, IP54 and IP54 R available as options
- Wheel-out power modules for improved manual handling
- Plug-in power connectors for easy maintenance and redundancy
- Power module redundancy for improved availability
- Factory-built cabinets ensure good installation and compliance with standards
- ATEX approved PTC interfaces and blanket certification with ABB motors



For further information see Technical Catalogue 3AFE 68375126

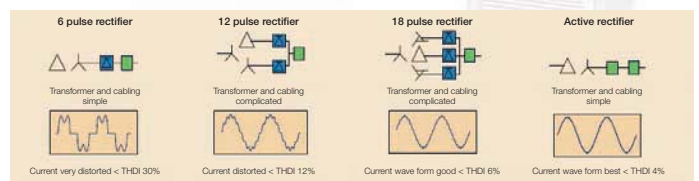

Alternatives in reducing line harmonics

Regenerative, active rectifier drive modules - low harmonic

Series ACS800-14

- 110 to 900 kW (380 - 480 V)
- IP00 kits
- Assembly kits for Rittal cabinets and generic cabinets
- Separate controllers for galvanic isolation
- Requires a separate +24 V DC supply at 3 A
- Active supply unit can be configured for low harmonic mode (2-4% harmonic distortion) or regenerative mode, for better dynamic performance
- Comprehensive installation instructions and CAD drawings



For further information see Technical Catalogue 3AFE 68404592

Other ABB drives



Module drives for system integrators

Series ACS850-04

- Module drive designed specifically for system integrators and panel builders
- Optimal power frame sizes and side-by-side mounting
- Power in at top, motor out at bottom for logical cable management within the cabinet
- DC bus connection - common DC link schemes are possible
- Integrated brake chopper - choppers in each module can be used when on a DC link, to distribute braking
- DTC motor control platform
- DriveStudio and DriveSPC PC tools for customising the parameter driven drive with IEC61131 application coding and software application blocks
- Memory module contains the complete firmware, parameter and program set-up – no re-commissioning
- STO, Safe Torque-Off to SIL3 as standard



For further information see Technical Catalogue 3AUA0000041481

ACS800 liquid cooled modules

Series ACS800-x04LC

- Extremely compact size, compared to air-cooled
- 98% of drive losses transferred to liquid - removes the need for air conditioned control rooms
- Tested electrical/mechanical kits available - which make different solutions easy to build
- ACAD, PDF and full 3D EPLAN® modelling support
- Pre-designed mounting frames available to reduce design time
- Liquid/liquid-heat exchanger assemblies can be supplied by ABB
- Module features:
 - Diode supply modules include line side chokes
 - Inverter modules include du/dt filters
 - Easy structure, fewer components
 - Inverter units, IGBT supply units and dynamic braking units are based on one common R8i module



For further information see Technical Catalogue 3AFE68404592

Other ABB drives



ABB industrial multidrives

A multidrive is a custom-made cabinet to suit a larger application or a process line. The cabinet contains multiple inverter stages of differing size, supplied from a common DC bus. The DC bus can be provided by a selection of supply units, diode, thyristor or IGBT (active supply unit).

Series ACS800 multidrive

- 1.5 to 5,600 kW, 380 - 690 V
- IP21 as standard, IP22, IP42 and IP54 as option
- Smaller power modules have high packing density, using a patented mounting arrangement
- Power modules on wheels for easy manual handling
- Plug-in power connectors for easy maintenance and redundancy
- Wide range of built-in options, including brake choppers, EMC filters, fuse switches, contactors, communication options etc
- ATEX approved PTC interfaces and blanket certification with ABB motors
- TÜV approved emergency stops



For further information see ACS800 Technical Catalogue 3AFE 68248531

ACS800 multidrive modules

- Arrange of IP20 module and IP00 kits to generate bespoke multidrive systems built into system integrators own panels
- Modules have no rectifiers, they are inverters only and range in frames from R2i to R8i (i=inverter only)
- A selection of rectifiers are also available to generate the DC link for the system. Diode, thyristor or active rectifier are available
- Cabinet kits for Rittal and generic, ensure easy integration
- ACAD, PDF and full 3D ØPLAN® modelling support



For further information see Technical Catalogue 3AFE68404592

ACS800LC liquid-cooled drives

- Power range 200 to 5,600 kW, (380-690 V)
- IP42 as standard, IP54 as option
- Provides reliable operation under extremely adverse conditions
- Silent and safe operation without the need for air ventilation or air conditioning, fully enclosed cabinets, smaller than previous generation
- Extensive range of cabinet options, including water pumping and heat exchanger cabinets
- Marine enclosure available
- Parallel modules allow redundant configuration
- Ideal where space is limited, in harsh environments, or at sites that require quieter operation, in applications where cooling water is freely available
- IEC, UL, CSA, Lloyds, DNV, ABS approvals
- ATEX-approved PTC interfaces and blanket certification with ABB motors



For further information see Technical Catalogue 3AFE68375126

Other ABB drives

Medium voltage drives



Medium voltage (MV) AC drives - 315 kW to 27 MW

- Medium voltage drives with reliable IGCT technology
- Complete package solutions available including transformers, drives and motors
- Complete range of drives for speed and torque control, also suitable for softstarting of large AC motors

Series ACS1000i

- Single drives 315 kW to 2000 kW
- Air-cooled 24-pulse drive with integrated input transformer
- Retrofit-ready for existing motors, suitable for most MV applications
- Integrated output sine filter for pure sinusoidal voltage and current output



Series ACS1000

- Single drives from 315 kW to 5 MW
- Air-cooled and water-cooled versions
- Retrofit ready for existing motors, suitable for most MV applications
- Integrated output sine filter for pure sinusoidal voltage and current output



Series ACS2000

- Single drives from 315 kW to 800 kW
- Active rectifier unit for 4-quadrant operation, reduced harmonics and adjustable power factor
- Direct-to-line version for operation without input transformer
- Multilevel topology allows the use of standard motors



Series ACS5000

- Single drives from 1.5 MW to 21 MW
- Air-cooled and water-cooled versions
- Multilevel topology allows the use of standard motors
- Multilevel, fuseless topology results in a drive with unbeatable efficiency, reliability and footprint
- Optimal network friendliness due to 36-pulse configuration



Other ABB drives

Medium voltage drives
DC drives



Series ACS6000

- Single or multi-drives 3 MW to 27 MW
- Active rectifier unit available for 4-quadrant operation, reduced harmonics and adjustable power factor
- Line supply unit available for 2-quadrant operation and a constant power factor of 0.96 across the whole speed range
- Modular design for optimum configurations, including multi-drive configurations

Medium voltage AC drives - 2 MW to 72 MW (higher on request)

- Complete range of drives and softstarters
- Complete package solutions including transformers, drives and motors

Series MEGADRIVE LCI

- High power with series connection of thyristors
- N+1 thyristor redundancy possible
- Fuseless design
- Water- and air-cooled converters available
- Line side harmonics: 6-pulse, 12-pulse or 24-pulse
- Motor side harmonics: 6-pulse or 12-pulse
- High converter efficiency
- Proven technology and design

ABB standard DC drives

Series DCS400

- Range from 20 to 820 A DC
- DCS400 is a digital DC drive targeted at OEMs, such as machine builders
- An integrated IGBT-based field supply results in less motor stress and better speed accuracy
- From 20 to 1,000 A at voltages up to 500 V AC (max. DC voltage 600 V)

ABB industrial DC drives

Series DCS800

- Wide power range, from 25 to 5,200 A
- Commissioning wizard gives easy start-up
- Easy to use - standard macros or user programmability
- Intuitive control panel with 'Help' key, consistent with many of the AC drives
- Adaptive programming for additional flexibility
- Modules can be connected in parallel up to 20,000 A
- Uses ACS800 I/O option modules and fieldbus modules
- I/O is backward compatible with DCS500 and DCS600
- Field converters built-in (up to 25 A)



Other ABB drives

HVAC drives and power quality filters

ABB standard drive for HVAC

Series ACH550-01 wall-mounted

Series ACH550-02 floor-standing

- Dedicated HVAC software with real-time clock
- Dedicated HVAC control panel, Hand/Off/Auto
- 15 dedicated HVAC user macros
- User-friendly control panel with HVAC assistants to aid commissioning - PID Assist, Comms Assist etc
- Swinging choke gives superior harmonic performance when slowing motors down, compared to conventional chokes
- IEC EN 61000-3-12 harmonic spectrum compliant
- BACnet, N2, FLN and Modbus embedded
- Fireman's override facility (Run to destruction)
- Now fitted with mains switch up to 22 kW



Power quality filters (PQF)

Overview

- Actively eliminates harmonics in a controlled way
- Filters up to 50th harmonic in accordance with G5/4 requirements
- Each harmonic individually programmable
- Active filters - only work when harmonics are present thereby reducing unwanted losses, resulting in greater overall efficiency
- Close loop for better measurement of harmonics - thereby more accurately eliminating the potentially damaging harmonic
- Auto-detection of CT polarity - ensures accurate current distortion readings on network, resulting in easy commissioning
- Stores record trail. Fault and event log - any trip will have a record trail



Series PQFM, PQFI

- Available in IP00 back plane or IP21, IP42 cabinets
- New intuitive user interface
- Current ratings, 70 A, 100 A, 130 A, 150 A, 250 A, 450 A, per module. The modules can be connected in parallel to a maximum of eight modules of equal rating

Series PQFs

- Small compact unit suitable for wall mounting
- Low ratings available from 30 A, 45 A, 60 A, 70 A, 80 A, 90 A, 100 A. The modules can be connected in parallel to a maximum of four modules of equal rating
- Same user interface as the larger units
- Available in IP 30



Remote monitoring options

Remote monitoring overview

– Remote monitoring is the reporting of information back to the user, from a remote station or location. Typical remote monitoring information can include:

- Energy consumption and savings
 - Motor condition
 - Warnings (predictive maintenance), faults and alarms
 - Diagnostics
 - Monitoring actual values and parameters
- Parameter access is possible, but is not the primary function of remote monitoring



Ethernet adapter – for machinery and standard drives

Series NETA-01 SREA-01 Ethernet adapter provides remote monitoring access for up to 10 drives. It connects to the drive(s) via an RS485 modbus interface. It can send process data, data logs and event messages independently, without a PLC or a dedicated on-site computer. The module can send either e-mails or SMS text messages to inform the user of the status of the drive(s) connected to it. It has an internal web server for easy configuration and drive access. Web pages can be configured with site photos and site naming.



Ethernet adapter for industrial drives

Series - RETA-01

RETA-01 module provides remote access to nine industrial drives. The module connects to the drive via a high speed optical connection that can be configured in a ring or star configuration. It can send process data, data logs and event messages independently, without a PLC or a dedicated on-site computer. The module can send either e-mails or SMS text messages to inform the user of the status of the drive(s) connected to it. It has an internal web server for easy configuration and drive access. Web pages can be configured with site naming. Full parameter access is possible.



Ethernet adapter for local Communication

Series - MOXA

Moxa module provides remote access to a single individual drive. The module connects to the drive via an RS232 connection to the keypad/panel port of the drive. It is a low cost point-to-point remote monitoring device. Moxa is ideal as a point-to-point device over which commissioning tools can be connected to the drive from a remote location, so diagnosis of faults and problems are possible.



High speed drive monitoring – remote diagnostics

Series – DriveMonitor

DriveMonitor is a service tool which can be fitted to any ABB industrial drive in case of site problems and issues. It uses high speed optical connections to the drives power stages and monitors all of the switching signals sent. In this way complicated system problems can be diagnosed. DriveMonitor can also be used as a system optimisation and recording tool, as its memory buffers can save up to one years worth of performance data.



Monitor drives on existing networks

Series – DriveBrowser PC tool

DriveBrowser allows a user to monitor any ABB drive connected to an existing Ethernet network, without having to connect another “tools” chain network on the site. Connect DriveBrowser to a suitable “hub” location and view, edit and tune all of the ABB drives on the Ethernet ring.

Software tools

ABB offers several software tools to facilitate and enhance the use of ABB drives. Especially when straightforward routines cannot be applied, these tools provide a user-friendly and easy-to-use approach for the selection, commissioning and use of AC drives.

Integration and programming tools

DriveOPC



For Windows™ based monitoring of ABB industrial drives.

This software package allows OLE for Process Control (OPC) communication between Windows applications and ABB drives.

DriveOPC enables remote connection over local area networks and can access all drives connected to the fast optical link of drives. The number of measuring points is not limited.

DriveAP

For adaptive programming of ABB industrial drives.

This PC tool is used to create, document, edit and download Adaptive Programs. Adaptive Programming can be done with the standard control panel or with DriveAP.



DriveAP offers a clear and easy way to develop, test and document Adaptive Programs with a PC. It modifies function blocks and their connections and requires no special programming.

DriveStudio

A user-friendly PC environment for simple drive commissioning tasks as well as more demanding drive tuning and programming tasks. DriveStudio is used with the ABB machinery drive and includes:

Commissioning and tuning

- Drive overview screen for fast parameter and function block navigation
- Parameter setting and signal monitoring
- Data logger and on-line signal monitoring for tuning
- Back-up and restore tool for drive parameter cloning and support

Solution programme composer

- Simple, easy-to-understand function block interface to drive firmware functions for signal monitoring and parameter setting

- Function block programming with standard function block library
- Professional programming environment: hierarchy levels, custom circuits, user parameters, copy protection etc.

DriveCAM tool

Multiple methods for designing axis profile between reference axis and controlled drive axis

Start-up and maintenance tools

DriveWindow

A Windows application used for commissioning and maintenance. Functions include local control, monitoring, parameter edits, fault logging, trending, backup and restore



- Shows actual status of the connected drive
- Edit and show the drive parameters
- Save and load drive parameters
- Backup and restore drive parameters
- Offline configuration of drive parameters
- Read fault loggers and diagnostic data

Used with ABB industrial drives equipped with high-speed fibre optic communication, or remotely via the Internet.

DriveWindow Light

Available for ABB standard drives and ABB general machinery drives, has the same functions as DriveWindow but is designed for point-to-point communication, via control panel port.

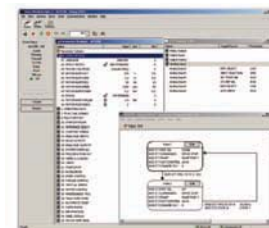

DriveConfig

Dedicated programming tool for the ABB component drive. Allows access to the extended parameter set of ACS55 and allows un-powered programming.



Drive Analyser

New PC tool to allow long term analysis of performance and diagnostics. Data can be collected for up to one year.

To download software tools, go to:
www.abb.com > drives > drive PC tools.

Software tools

Engineering tools

DriveSize

For dimensioning drives and motors.



This PC programme helps select an optimal motor, frequency converter and transformer, especially useful where a straightforward selection from a catalogue is not possible. DriveSize is used to compute network harmonics and to create

documents about dimensioning. It contains current versions of ABB's motor and frequency converter catalogues.

It can also be used in conjunction with ABB machinery drives to specify the dimensions of different kinds of linear or rotary movement mechanisms such as lead screws, rack and pinion combinations, belts and pulleys, conveyors, feed rolls and rotating tables.

DriveSize software can be used in Win98, WinNT, Win2000 and WinXP operating systems.

DriveChopper



For dimensioning a braking chopper and resistor.

DriveChopper is a web tool for braking chopper and resistor dimensioning (visit www.abb.co.uk/energy). The programme is created especially for system designers who need a braking unit for a particular drive application.

DriveUpgrade

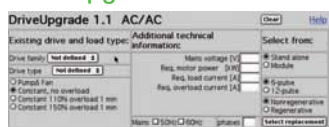

For finding an adequate drive to replace an old one.

This on-line tool is ideal for finding a replacement to an

existing ABB drive that may be coming to the end of its useful life. Simply input some basic information and the modern equivalent drive will be revealed.

To download, go to: www.abb.com > drives > drive PC tools.

Energy saving tools

For comparison of energy consumption between different flow control methods in pumps and fans, ABB has developed calculation tools for estimating the energy savings that

become available when applying electric speed control to certain flow machines. Using PumpSave and FanSave tools, AC drive control in pumps and fans can be compared against traditional flow control methods in terms of energy usage. The tools also provide financial figures for assessing the profitability of purchasing an ABB drive.



PumpSave

For comparing AC drive control against throttling, on/off and hydraulic coupling control in pumps. Calculate how much energy and money you could be saving with ABB drives while also deriving other benefits such as softstarting and stopping, an improved power factor and connection into process automation. PumpSave also carries out a simple dimensioning and recommends an appropriate ABB drive type. Medium voltage drives now included.

FanSave

For comparing AC drive control against traditional flow control methods in fans. Calculate the savings you can achieve by replacing outlet damper, inlet vane or pitch control methods with electronic speed control from an ABB drive. FanSave also provides financial and environmental figures concerning the control method retrofit project and recommends a suitable ABB drive type.

Award winning 6-step energy saving plan

ABB has developed six easy steps that help determine where AC drives can be best used and what could be the potential energy saving. The six steps look at the facts behind climate change and the need to save energy; the actual savings that can be made; the finance options available to pay for the AC drives; the different AC drive products available; application references; and an action plan which includes two on-line energy saving calculator tools.

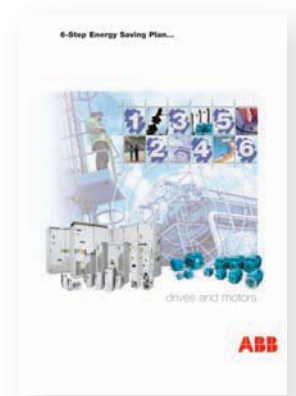

To download a series of energy saving tools go to: www.abb.co.uk/energy

Drive services

Service options for variable speed drives

A proactive drives maintenance programme keeps you competitive by minimising disruption to your production.

The many drives used in industry have a high degree of reliance placed upon them. Although drives are not normally the most expensive pieces of capital equipment, they often perform critical duties and have a high in-service value. A drive failure can result in loss of production and revenues, as well as having safety and environmental consequences. To reduce the risk and consequences of failure, the drive must be properly maintained at the right times in its lifecycle.

ABB provides three levels of service for your drives; DrivesActive, DrivesActive+ and DrivesAdvantage. The three service levels mean your exact operational and financial needs can be met, maximising the reliability of your plant over its entire lifecycle. Elements from the three levels can be combined into a service contract.

DrivesActive

A proactive service that provides 24/7 support with a high level of technical expertise. Its emphasis lies on delivering the right level of service for the circumstances. It is a lifecycle management programme that captures ABB's expertise from the installed base. DrivesActive goes beyond routine maintenance to maximise the reliability and performance of your drives.

- Telephone support
- 24/7 support
- Drive commissioning
- Spare parts – repair, exchange and inventory support
- Training
- On-site and workshop repairs
- Planned preventive maintenance
- Resource bank – engineer hours available when you need them
- ReFLEX – scaleable support to meet operational and budgetary needs

DrivesActive+

A lifecycle management programme that focuses on extending the life of critical equipment. It adopts the most effective maintenance methodology for the application based on the probability of failure and the severity of its consequences.

- Lifecycle management
- Drive system analysis
- Harmonic surveys

The full portfolio of DrivesActive and DrivesActive+ services is described in a separate brochure that is available on request - please call 07002 SERVICE (07002 7378423) for a copy.

DrivesAdvantage

A service provided by ABB's certified partners on the current range of products up to 400 kW. Services include installation, start-up assistance and after-sales service, backed by ABB's experts. It also offers recycling of old ABB drives or non-ABB drives to ISO 14001. The service is local to your plant or production facility.

- Upgrades
- Hire services
- Planned maintenance
- Repairs
- Energy surveys
- Training

The full portfolio of DrivesAdvantage services is described in a separate brochure that is available on request - please call 07000 DRIVES (07000 374837) for a copy.

ABB University - Professional drives training

www.abb.com/abbuniversity

Factory certified courses delivered in a bespoke drives training facility by experienced applications and service personnel. With ABB University you can enrol onto either e-learning or classroom based courses. Please call 01952 228024.

Low voltage AC motors

Sizes 56-450

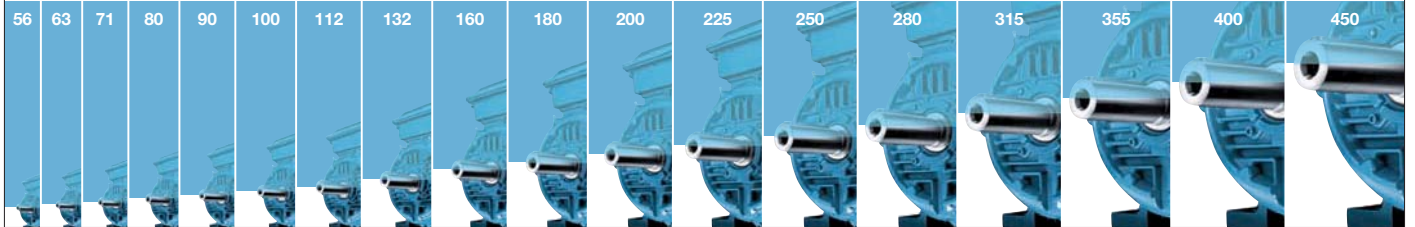

Process performance motors - page 54

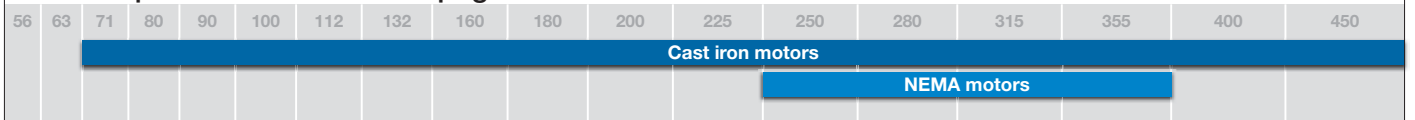

Industrial performance motors - page 55

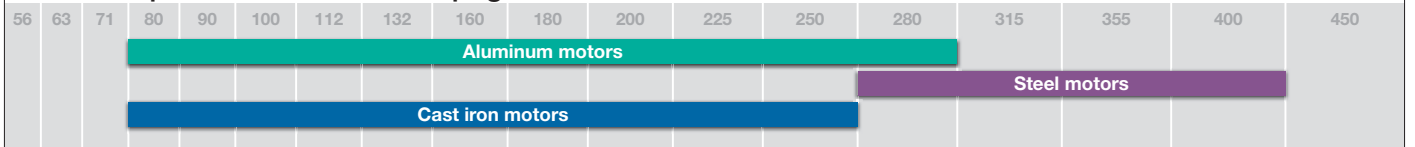

Motors for hazardous areas - page 56

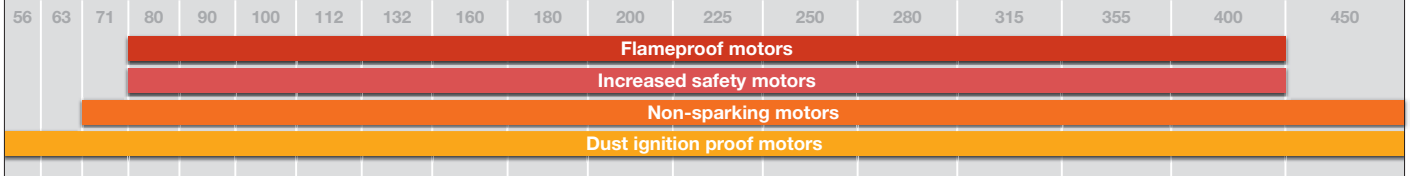

Marine motors

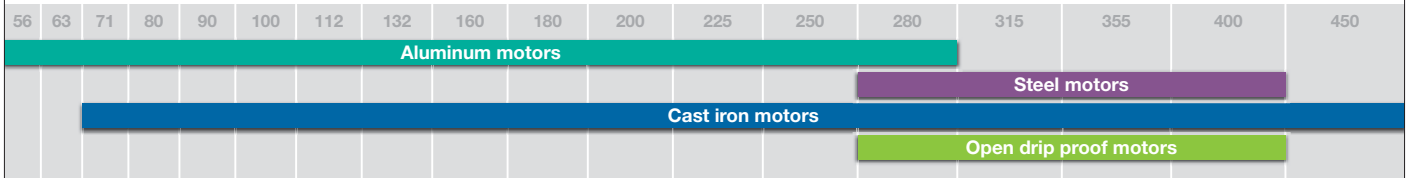

Motors for additional applications

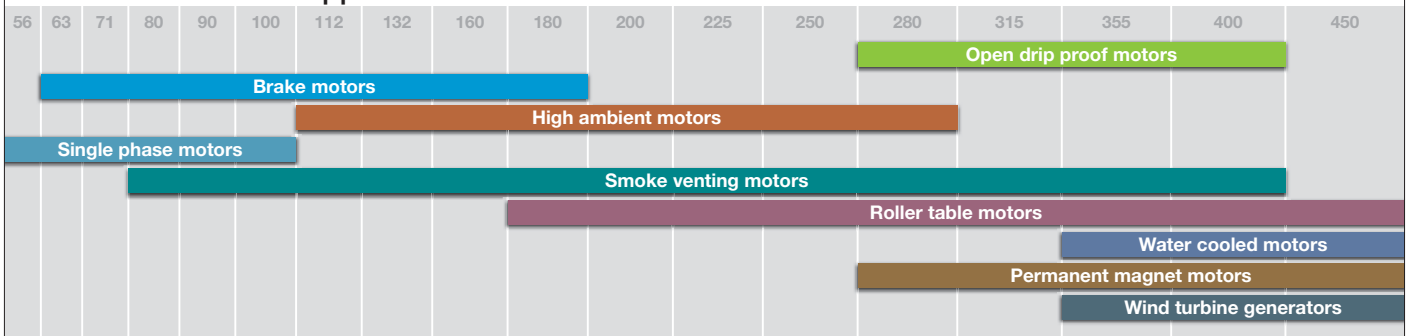

For more information call 07000 MOTORS (07000 668677)

Low voltage AC motors

European MEPS for low voltage motors

2009

EuP Directive
2005/32/EC
Eco-design
formally
adopted 2009

Mandatory EuP Directive

Applies to motors:

- rated voltage up to 1000 V
- single-speed, three-phase, 50 Hz
- 2, 4 and 6-pole
- rated output from 0.75 to 375 kW
- S1 Duty

Does not apply to motors designed to operate:

- in potentially explosive atmospheres as defined in ATEX directive 94/9/EC
- brake motors
- ambient air temperature outside the range -15°C...+40°C
- altitudes exceeding 1000m asl
- maximum operating air temperature above 40°C

Implementation timetable

Phase 1

From 16 June, 2011

Motors must meet the IE2 efficiency level

Phase 2

From 1 January, 2015

Motors with a rated output of 7.5 - 375 kW must meet EITHER the IE3 efficiency level OR the IE2 level if fitted with variable speed drive

Phase 3

From 1 January, 2017

Motors with a rated output of 0.75 - 375 kW must meet EITHER the IE3 efficiency level OR the IE2 level if fitted with variable speed drive

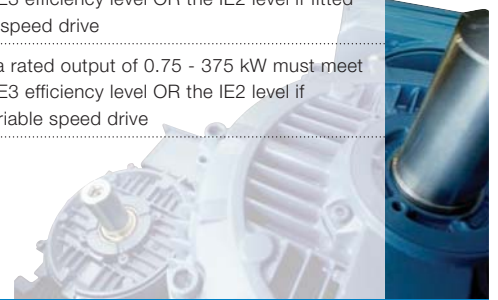

2008

IEC 60034-30

Standard for LV motor efficiency classes

Motors covered by standard include:

- Single-speed, three-phase, 50 and 60 Hz
- 2, 4 or 6-pole
 - Rated output from 0.75 to 375 kW
 - Rated voltage U_N up to 1000 V
 - Duty type S1 (continuous duty) or S3 (intermittent periodic duty) with a rated cyclic duration factor of 80% or higher
 - Capable of operating direct online 50 and 60 Hz

Super premium efficiency

IE4

Not yet defined

Premium efficiency

IE3

Premium

High efficiency

IE2

Comparable to Eff1

Standard efficiency

IE1

Comparable to Eff2

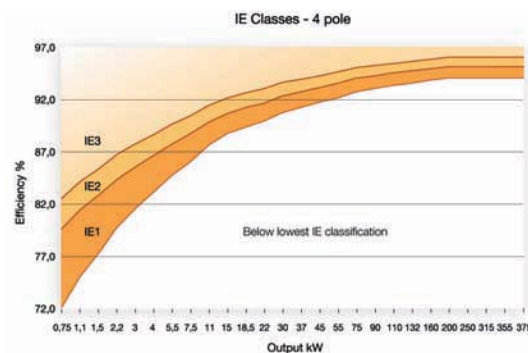

2007

IEC 60034-2-1

Standard on efficiency measurement methods

Introduces new rules concerning the testing methods to be used for determining losses and efficiency.

The resulting efficiency values differ from those obtained under the previous IEC testing standard IEC 60034-2: 1996

ABB calculates efficiency values according to the indirect method, with additional losses determined from measurement. This is the preferred low uncertainty method outlined in the standard.



For more information call 07000 MOTORS (07000 668677)

Low voltage AC motors

Process performance motors and Industrial performance motors

What is a Process performance motor?

Process performance motors are the flagship of ABB's standard low voltage motors. This range provides the most comprehensive, versatile set of motors for the process industries and heavy-duty applications which are dependent on continuous reliability, lowest possible environmental impact and lifecycle costs. Their superior ability to perform reliably and efficiently, continuously and even under the most challenging circumstances, ensures that they power their way through the toughest tasks and conditions. As such they come with a three years warranty that can be extended to five years.

Where can it be used

- End-users in continuous process industries
- Project OEMs
- EPCs
- Demanding industries:
 - pulp and paper
 - metals
 - minerals and mining



Highlights - Process performance motor

- All variant codes possible for process industry
- Application understanding and engineering
- With three years warranty and option to extend to five years
- Highest efficiency (EFF1 today) Premium Efficiency as option

What is an Industrial performance motor?

Industrial performance motors combine convenience and easy handling seamlessly with ABB's engineering expertise, at the same time providing a wide range of add-on variants and applications. The motors can be tailored according to the specific needs of OEMs and demanding industries. The high modularity enables adding a wide variety of elements to the robust frame, thus making the overall solution to fit the specific situation and customer need perfectly. As the user only pays for the enhancements needed and used, the motors are free from all unnecessary elements.

Where can it be used

- End-users in industry
- Tailored serial/project OEM's
- Pumps
- Fans
- Compressors



Highlights - Industrial performance motor

- Variant codes from production that OEM customers need
- Two years warranty
- Highest efficiency (EFF1/IE2 today)
- High-output options
- All poles and multi-pole variants

Process performance motors

Cast iron motors

TEFC low voltage motors, cast iron frame, IP55, IC 411, single-speed

IE2



Output kW	Frame Size	Torque Nm	Current I	Eff*	Foot Price	Flange Price	
3000 r/min = 2 poles							
11	M3BP 160 MLA	36.0	19.2	89.8	£1,062	£1,169	
15	M3BP 160 MLB	49.0	26.0	90.7	£1,262	£1,376	
18.5	M3BP 160 MLC	60.0	32.5	91.3	£1,540	£1,641	
22	M3BP 160 MLD	72.0	37.5	91.4	£1,804	£1,877	HO
22	M3BP 180 MLA	71.0	39.0	91.6	£1,877	£1,964	
30	M3BP 160 MLE	98.0	51.0	91.8	£2,270	£2,402	HO
30	M3BP 180 MLB	97.0	53.0	82.2	£2,270	£2,402	HO
30	M3BP 200 MLA	97.0	52.0	92.3	£2,431	£2,533	
37	M3BP 200 MLB	120.0	64.0	92.7	£3,540	£3,685	
45	M3BP 200 MLC	146.0	77.0	93.0	£4,068	£4,217	HO
45	M3BP 225 SMA	145.0	79.0	93.6	£4,522	£4,681	
55	M3BP 200 MLD	178.0	94.0	93.3	£5,180	£5,385	HO
55	M3BP 225 SMB	177.0	96.0	93.9	£5,180	£5,385	HO
55	M3BP 250 SMA	177.0	96.0	93.9	£5,413	£5,591	
75	M3BP 225 SMC	242.0	132.0	94.5	£6,450	£6,650	HO
75	M3BP 280 SMA	240.0	131.0	94.3	£6,917	£7,314	
90	M3BP 250 SMC	289.0	154.0	94.6	£7,500	£7,680	HO
90	M3BP 280 SMB	289.0	152.0	94.6	£7,875	£8,114	
110	M3BP 280 SMC	353.0	185.0	95.1	£9,511	£9,834	HO
110	M3BP 315 SMA	352.0	194.0	94.7	£10,373	£10,714	
132	M3BP 315 SMB	423.0	228.0	95.1	£11,467	£11,819	
160	M3BP 315 SMC	513.0	269.0	95.4	£13,106	£13,461	
200	M3BP 315 MLA	641.0	336.0	95.7	£18,246	£20,021	
250	M3BP 315 LKA	801.0	422.0	96.1	£21,636	£22,282	HO
250	M3BP 355 SMA	800.0	425.0	96.3	£23,088	£24,218	
315	M3BP 315 LKC	1009.0	530.0	96.4	£27,126	£27,771	HO
315	M3BP 355 SMB	1009.0	535.0	96.6	£29,061	£30,192	
355	M3BP 355 SMC	1136.0	604.0	96.8	£32,777	£33,906	
400	M3BP 355 MLA	1281.0	680.0	96.9	£36,650	£37,780	
450	M3BP 355 MLB	1441.0	750.0	97.1	£41,815	£42,946	
500	M3BP 355 LKA	1601.0	830.0	97.1	£44,560	£45,689	
560	M3BP 355 LKB	1793.0	930.0	97.2	£50,049	£51,179	
560	M3BP 400 LA	1790.0	940.0	97.2	£52,470	£53,923	
560	M3BP 400 LKA	1790.0	940.0	97.2	£53,905	£55,357	
630	M3BP 400 LB	2014.0	1055.0	97.4	£59,716	£61,168	
630	M3BP 400 LKB	2014.0	1055.0	97.4	£58,281	£59,734	
710	M3BP 400 LC	2270.0	1185.0	97.5	£67,142	£68,592	
710	M3BP 400 LKC	2270.0	1185.0	97.5	£65,708	£67,159	

HO = High-output design

Output kW	Frame Size	Torque Nm	Current I	Eff*	Foot Price	Flange Price	
1500 r/min = 4 poles							
11	M3BP 160 MLA	71.0	21.0	90.5	£1,053	£1,160	
15	M3BP 160 MLB	98.0	28.5	91.4	£1,313	£1,443	
18.5	M3BP 160 MLC	121.0	34.5	91.2	£1,496	£1,613	HO
18.5	M3BP 180 MLA	120.0	35.0	91.9	£1,571	£1,672	
22	M3BP 160 MLD	144.0	41.0	91.3	£1,835	£1,900	HO
22	M3BP 180 MLB	194.0	41.0	92.1	£1,877	£1,949	
30	M3BP 180 MLC	194.0	57.0	92.4	£2,197	£2,329	HO
30	M3BP 200 MLA	194.0	55.0	92.9	£2,461	£2,593	
37	M3BP 200 MLB	239.0	68.0	93.0	£3,046	£3,236	HO
37	M3BP 225 SMA	239.0	68.0	93.2	£3,309	£3,484	
45	M3BP 200 MLC	291.0	84.0	93.3	£3,700	£3,860	HO
45	M3BP 225 SMB	290.0	82.0	93.6	£3,878	£4,068	
55	M3BP 225 SMC	356.0	99.0	93.5	£4,551	£4,772	HO
55	M3BP 250 SMA	355.0	100.0	94.0	£4,681	£4,903	
73	M3BP 225 SMD	473.0	134.0	93.2	£5,450	£5,760	HO
75	M3BP 250 SMB	484.0	136.0	94.4	£5,631	£5,999	HO
75	M3BP 280 SMA	483.0	135.0	94.5	£5,897	£6,251	
90	M3BP 250 SMC	582.0	162.0	94.3	£6,950	£7,100	HO
90	M3BP 280 SMB	580.0	159.0	94.7	£7,079	£7,449	
110	M3BP 280 SMC	707.0	195.0	95.1	£8,071	£8,439	HO
110	M3BP 315 SMA	706.0	193.0	95.1	£8,734	£9,119	
132	M3BP 315 SMB	848.0	232.0	95.4	£10,316	£10,669	
160	M3BP 315 SMC	1028.0	287.0	95.6	£12,057	£12,411	
200	M3BP 315 MLA	1285.0	351.0	95.6	£17,138	£17,582	
250	M3BP 315 LKA	1605.0	442.0	95.5	£18,761	£19,353	HO
250	M3BP 355 SMA	1604.0	438.0	96.2	£20,239	£20,831	
280	M3BP 315 LKB	1798.0	482.0	95.7	£23,193	£23,783	HO
315	M3BP 315 LKC	2022.0	548.0	95.7	£25,408	£25,999	HO
315	M3BP 355 SMB	2022.0	550.0	96.3	£26,886	£27,772	
355	M3BP 355 SMC	2280.0	616.0	96.2	£28,660	£29,544	
400	M3BP 355 MLA	2565.0	700.0	96.3	£32,499	£33,089	
450	M3BP 355 MLB	2884.0	784.0	96.8	£36,782	£37,078	
500	M3BP 355 LKA	3204.0	875.0	97.0	£40,771	£41,066	
560	M3BP 355 LKB	3589.0	990.0	96.8	£44,464	£44,758	
560	M3BP 400 LA	3587.0	980.0	97.0	£46,679	£47,269	
560	M3BP 400 LKA	3587.0	980.0	97.0	£46,679	£47,269	
630	M3BP 400 LB	4035.0	1085.0	97.1	£51,849	£52,438	
630	M3BP 400 LKB	4035.0	1085.0	97.1	£54,407	£55,858	
710	M3BP 400 LC	4547.0	1240.0	97.3	£61,348	£62,800	
710	M3BP 400 LKC	4547.0	1240.0	97.3	£62,784	£64,235	

Industrial performance motors

Aluminium motors

TEFC low voltage motors, aluminium, IP55, IC 411, single-speed

IE2



Output kW	Frame Size	Torque Nm	Current I	Eff*	Foot Price	Flange Price
3000 r/min = 2 poles						
1.1	M3AA 80 C	3.6	2.4	82.3	£235	£270
1.5	M3AA 90 L	5.0	2.9	84.1	£280	£316
2.2	M3AA 90 LB	7.3	4.4	84.1	£346	£382
3	M3AA 100 LB	9.8	5.9	87.1	£421	£468
4	M3AA 112 MB	13.2	7.3	86.6	£499	£547
5.5	M3AA 132 SB	18.0	10.7	87.8	£653	£716
7.5	M3AA 132 SC	24.7	13.6	88.7	£829	£894
11	M3AA 160 MLA	36.0	19.2	89.8	£1,006	£1,113
15	M3AA 160 MLB	49.0	26.0	90.7	£1,163	£1,271
18.5	M3AA 160 MLC	60.0	32.5	91.3	£1,443	£1,554
22	M3AA 180 MLA	71.0	39.0	91.6	£1,766	£1,875
30	M3AA 200 MLA	97.0	52.0	92.3	£2,284	£2,422
37	M3AA 200 MLB	120.0	64.0	92.7	£2,512	£2,663
45	M3AA 225 SMA	145.0	79.0	93.6	£4,288	£4,472
55	M3AA 250 SMA	177.0	96.0	93.9	£5,017	£5,217
75	M3AA 280 SMA	241.0	129.0	94.5	£6,193	£6,354
75	M2CA 280 SA	241.0	131.0	94.2	£5,220	£5,539
90	M3AA 280 SMB	289.0	153.0	94.6	£7,256	£7,448
90	M2CA 280 SMA	289.0	152.0	94.5	£6,269	£6,589
110	M2CA 315 SA	352.0	194.0	94.6	£7,653	£8,185
132	M2CA 315 SMA	423.0	228.0	95.0	£9,246	£9,779
160	M2CA 315 MB	513.0	269.0	95.3	£11,469	£12,001
200	M2CA 315 LA	641.0	334.0	95.6	£14,406	£14,965
200	M2CA 355 SA	641.0	338.0	95.5	£15,245	£16,222
250	M2CA 355 MA	800.0	422.0	96.1	£18,179	£19,159
280	M2CA 355 MB	897.0	472.0	96.1	£20,836	£21,815
315	M2CA 355 LA	1009.0	535.0	96.4	£22,795	£23,773
355	M2CA 355 LB	1136.0	603.0	96.5	£25,032	£26,011
400	M2CA 400 MLA	1280.0	675.0	96.8	£30,205	£31,463
450	M2CA 400 MLB	1438.0	743.0	97.0	£34,400	£35,657
500	M2CA 400 LKA	1598.0	825.0	97.1	£36,778	£38,034
560	M2CA 400 LKB	1790.0	940.0	97.2	£41,250	£42,508

*Eff = Efficiency at full load 100%

Output kW	Frame Size	Torque Nm	Current I	Eff*	Foot Price	Flange Price
1500 r/min = 4 poles						
0.75	M3AA 80 D	5.1	1.8	81.1	£230	£252
1.1	M3AA 90 LB	7.3	2.5	83.2	£288	£318
1.5	M3AA 90 LD	9.9	3.1	84.1	£346	£377
2.2	M3AA 100 LC	14.5	4.7	86.6	£393	£438
3	M3AA 100 LD	19.8	6.3	86.4	£440	£485
4	M3AA 112 MB	26.4	8.6	87.4	£526	£574
5.5	M3AA 132 M	35.9	11.2	89.0	£673	£734
7.5	M3AA 132 MA	48.7	15.3	90.0	£865	£929
11	M3AA 160 MLA	71.0	21.0	90.5	£1,015	£1,121
15	M3AA 160 MLB	98.0	28.5	91.4	£1,213	£1,320
18.5	M3AA 180 MLA	120.0	35.0	91.9	£1,524	£1,631
22	M3AA 180 MLB	142.0	41.0	92.1	£1,796	£1,888
30	M3AA 200 MLA	194.0	55.0	92.9	£2,238	£2,345
37	M3AA 225 SMA	239.0	68.0	93.2	£3,012	£3,224
45	M3AA 225 SMB	290.0	82.0	93.6	£3,666	£3,879
55	M3AA 250 SMA	355.0	100.0	94.0	£4,380	£4,561
75	M3AA 280 SMA	484.0	137.0	94.3	£5,616	£5,809
75	M2CA 280SA	483.0	137.0	94.0	£5,051	£5,373
90	M3AA 280 SMB	582.0	162.0	94.2	£6,589	£6,768
90	M2CA 280 SMA	579.0	163.0	94.6	£5,906	£6,226
110	M2CA 315 SA	706.0	198.0	94.8	£7,330	£7,863
132	M2CA 315 SMA	848.0	238.0	95.1	£8,828	£9,359
160	M2CA 315 MB	1028.0	282.0	95.5	£10,685	£11,218
200	M2CA 315 LA	1285.0	351.0	95.6	£13,567	£14,126
200	M2CA 355 SA	1284.0	350.0	95.6	£14,126	£15,105
250	M2CA 355 MA	1603.0	435.0	95.8	£16,781	£17,761
315	M2CA 355 LA	2022.0	550.0	95.7	£21,398	£22,375
355	M2CA 355 LB	2277.0	615.0	96.1	£24,194	£25,170
400	M2CA 355 LKD	2564.0	684.0	96.2	£26,849	£27,829
450	M2CA 400 MLA	2882.0	772.0	96.6	£31,743	£33,000
500	M2CA 400 MLB	3202.0	867.0	96.7	£35,379	£36,635
560	M2CA 400 LKA	3587.0	982.0	96.7	£38,314	£39,573
630	M2CA 400 LKB	4034.0	1077.0	96.9	£42,649	£43,906

Hazardous area motors

Flameproof motors, 71-400, Ex d/e* IIB T4
TEFC low voltage motors, IP55, IC 411, single-speed

Blanket certification

An ATEX approved AC motor and AC drive combination gives safe, economical power combined with effective control. By choosing an ABB ATEX package, end-users can be confident that the motor and drive combination is optimised for their application.



ATEX
Certified

Output kW	Frame Size	Torque Nm	Current I	Eff*	Foot Price	Flange Price	
3000 r/min = 2 poles							
0.37	MJA/KA 71 A	1.20	0.96	68.0	£497	£572	
0.55	MJA/KA 71 B	1.88	1.20	76.0	£528	£605	
0.75	M3JP/KP 80 MA	2.50	1.62	77.2	£685	£730	
1.1	M3JP/KP 80 MB	3.70	2.21	81.1	£718	£787	
1.5	M3JP/KP 90 SLA	5.00	3.00	81.9	£794	£862	
2.2	M3JP/KP 90 SLC	7.30	4.19	84.6	£942	£1,001	
3	M3JP/KP 100 LA	10.0	5.50	85.9	£998	£1,065	
4	M3JP/KP 112 MB	13.0	7.50	87.1	£1,239	£1,321	
5.5	M3JP/KP 132 SMB	18.0	10.4	87.0	£1,440	£1,514	
7.5	M3JP/KP 132 SMD	25.0	13.8	88.5	£1,834	£1,895	
9.2	M3JP/KP 132 SME	30.6	17.1	85.6	£2,060	£2,127	HO
11	M3JP/KP 160 MLA	36.0	20.0	91.2	£2,122	£2,273	ECA
15	M3JP/KP 160 MLB	49.0	28.0	91.6	£2,515	£2,621	ECA
18.5	M3JP/KP 160 MLC	60.0	33.0	92.4	£2,861	£2,938	ECA
22	M3JP/KP 180 MLA	72.0	39.0	92.6	£3,544	£3,664	ECA
22	M3JP/KP 160 MLD	72.0	39.0	91.4	£3,330	£3,437	HO
30	M3JP/KP 200 MLA	97.0	54.0	94.0	£4,511	£4,692	ECA
30	M3JP/KP 180 MLB	97.0	54.0	92.8	£4,222	£4,345	HO
37	M3JP/KP 200 MLC	120	65.0	94.1	£5,994	£6,265	ECA
37	M3JP/KP 180 MLC	120	65.0	93.7	£5,911	£6,137	HO,ECA
45	M3JP/KP 225 SMB	145	79.0	94.7	£8,109	£8,411	ECA
45	M3JP/KP 200 MLE	146	79.0	93.7	£7,640	£7,978	HO,ECA
55	M3JP/KP 250 SMA	177	96.0	94.6	£10,666	£11,059	ECA
55	M3JP/KP 225 SMC	177	96.0	94.3	£10,016	£10,394	HO
67	M3JP/KP 225 SMD	216	120	94.4	£11,329	£12,027	HO
75	M3JP/KP 280 SMA	240	131	94.8	£14,461	£14,944	ECA
75	M3JP/KP 250 SMB	241	129	95.1	£13,507	£13,976	HO,ECA
90	M3JP/KP 280 SMB	289	152	95.1	£18,908	£19,514	ECA
90	M3JP/KP 250 SMC	290	153	94.9	£15,111	£16,076	HO
110	M3JP/KP 315 SMA	352	194	95.1	£22,839	£23,292	ECA
110	M3JP/KP 280 SMC	353	185	95.7	£21,477	£21,933	HO,ECA
132	M3JP/KP 315 SMB	423	228	95.4	£27,074	£27,526	ECA
160	M3JP/KP 315 SMC	513	269	96.1	£30,702	£31,155	ECA
200	M3JP/KP 315 MLA	641	336	96.3	£38,565	£39,019	ECA
250	M3JP/KP 355 SMA	800	415	96.3	£42,009	£43,229	ECA
315	M3JP/KP 355 SMB	1009	535	96.5	£51,073	£52,293	ECA
355	M3JP/KP 355 SMC	1136	604	96.7	£54,907	£56,126	ECA
400	M3JP/KP 355 MLA	1281	680	96.8	£60,832	£62,052	ECA
450	M3JP/KP 355 MLB	1441	750	97.0	£67,978	£69,199	
500	M3JP/KP 355 LKA	1601	830	97.0	£79,134	£80,354	
560	M3JP/KP 400 LA	1790	940	97.2	£108,732	£111,908	

Output kW	Frame Size	Torque Nm	Current I	Eff*	Foot Price	Flange Price	
1500 r/min = 4 poles							
0.25	MJA/KA 71 A	1.73	0.65	71.0	£489	£567	
0.37	MJA/KA 71 B	2.55	1.00	72.0	£524	£599	
0.55	M3JP/KP 80 MA	3.70	1.40	76.1	£627	£685	
0.75	M3JP/KP 80 MB	5.10	1.80	77.3	£655	£718	
1.1	M3JP/KP 90 SLA	7.30	2.48	79.9	£698	£759	
1.5	M3JP/KP 90 SLC	10.0	3.31	80.9	£767	£833	
2.2	M3JP/KP 100 LA	14.5	4.40	85.8	£836	£904	
3	M3JP/KP 100 LB	20.0	6.10	85.5	£1,089	£1,154	
4	M3JP/KP 112 MC	27.0	8.40	85.0	£1,163	£1,249	
5.5	M3JP/KP 132 SMB	36.0	11.4	87.0	£1,539	£1,625	
7.5	M3JP/KP 132 SMD	50.0	15.4	87.9	£1,712	£1,804	
9.2	M3JP/KP 132 SME	62.0	18.5	85.8	£1,993	£2,084	HO
11	M3JP/KP 160 MLC	71.0	22.5	91.3	£2,135	£2,242	ECA
15	M3JP/KP 160 MLE	98.0	30.0	92.0	£2,649	£2,743	ECA
18.5	M3JP/KP 180 MLA	120	36.0	92.5	£3,316	£3,451	ECA
18.5	M3JP/KP 160 MLF	120	36.5	92.3	£3,119	£3,210	HO,ECA
22	M3JP/KP 180 MLB	143	42.0	92.6	£3,680	£3,815	ECA
22	M3JP/KP 160 MLG	143	44.5	91.8	£3,495	£3,618	HO
30	M3JP/KP 200 MLB	194	56.0	93.5	£4,602	£4,769	ECA
30	M3JP/KP 180 MLC	194	59.0	92.3	£4,314	£4,434	HO
37	M3JP/KP 225 SMB	239	69.0	93.6	£5,662	£5,873	ECA
37	M3JP/KP 200 MLC	239	70.0	93.3	£5,251	£5,434	HO
45	M3JP/KP 225 SMC	291	81.0	94.4	£6,689	£6,915	ECA
55	M3JP/KP 250 SMA	355	101	94.6	£8,201	£8,593	ECA
55	M3JP/KP 225 SMD	356	100	94.0	£7,746	£8,123	HO
75	M3JP/KP 280 SMA	483	135	94.9	£10,758	£11,255	ECA
75	M3JP/KP 250 SMB	485	133	94.7	£10,121	£10,589	HO,ECA
90	M3JP/KP 280 SMB	580	159	95.2	£14,824	£15,278	ECA
110	M3JP/KP 315 SMA	706	193	95.6	£16,942	£17,546	ECA
110	M3JP/KP 280 SMC	707	195	95.6	£16,791	£17,244	HO,ECA
132	M3JP/KP 315 SMB	848	232	95.8	£20,721	£21,174	ECA
160	M3JP/KP 315 SMC	1028	287	96.0	£22,839	£23,292	ECA
200	M3JP/KP 315 MLA	1285	351	96.2	£30,098	£30,550	ECA
250	M3JP/KP 355 SMA	1604	438	96.5	£37,659	£38,717	ECA
315	M3JP/KP 355 SMB	2022	550	96.7	£47,488	£48,546	ECA
355	M3JP/KP 355 SMC	2280	616	96.7	£53,536	£54,595	ECA
400	M3JP/KP 355 MLA	2565	700	96.9	£60,190	£61,552	ECA
450	M3JP/KP 355 MLB	2884	784	96.9	£66,932	£68,151	
500	M3JP/KP 355 LKA	3204	875	97.0	£74,079	£75,299	
560	M3JP/KP 400 LA	3587	980	97.0	£84,363	£85,930	
630	M3JP/KP 400 LB	4035	1085	97.0	£94,972	£98,450	

HO = High-output design ECA = ECA Compliant *Eff = Efficiency at full load 100%

Hazardous area motors

Non-sparking motors, 71-400, ExnA T3 cast iron frame
TEFC low voltage motors, IP55, IC 411, single-speed

ATEX
Certified



Output kW	Frame Size	Torque Nm	Current I	Eff*	Foot Price	Flange Price	
3000 r/min = 2 poles							
0.37	M2BA 71 M2A	1.30	1.00	69.0	£250	£274	
0.55	M2BA 71 M2B	1.88	1.30	71.9	£265	£290	
0.75	M2BA 80 M2A	2.50	1.60	75.7	£281	£307	
1.1	M2BA 80 M2B	3.70	2.30	77.5	£303	£327	
1.5	M2BA 90 S2A	5.00	3.12	79.7	£347	£377	
2.2	M2BA 90 L2A	7.40	4.50	81.4	£406	£435	
3	M2BA 100 L2A	10.0	5.97	82.6	£465	£504	
4	M2BA 112 M2A	13.0	7.60	84.6	£554	£599	
5.5	M2BA 132 S2A	18.0	10.5	87.2	£684	£744	
7.5	M2BA 132 S2B	25.0	13.8	89.0	£828	£887	
11	M3GP 160 MLA	36.0	20.0	91.2	£1,186	£1,281	ECA
15	M3GP 160 MLB	49.0	28.0	91.6	£1,501	£1,596	ECA
18.5	M3GP 160 MLC	60.0	33.0	92.4	£1,753	£1,850	ECA
22	M3GP 180 MLA	72.0	39.0	92.6	£2,048	£2,182	ECA
22	M3GP 160 MLD	72.0	39.0	91.4	£1,931	£2,026	HO
30	M3GP 200 MLA	97.0	54.0	94.0	£2,613	£2,793	ECA
30	M3GP 180 MLB	97.0	54.0	92.8	£2,404	£2,538	HO
37	M3GP 200 MLC	120	65.0	94.1	£3,615	£3,794	ECA
37	M3GP 180 MLC	120	65.0	93.7	£3,161	£3,295	HO,ECA
45	M3GP 225 SMB	145	79.0	94.7	£4,618	£4,826	ECA
45	M3GP 200 MLE	146	79.0	93.7	£4,155	£4,334	HO,ECA
55	M3GP 250 SMA	177	96.0	94.6	£5,527	£5,764	ECA
55	M3GP 225 SMC	177	96.0	94.3	£5,289	£5,497	HO,ECA
67	M3GP 225 SMD	216	120	94.4	£5,624	£5,832	HO
75	M3GP 280 SMA	240	131	94.8	£7,264	£7,587	ECA
75	M3GP 250 SMB	241	129	95.1	£6,669	£6,907	HO,ECA
90	M3GP 280 SMB	289	152	95.1	£8,270	£8,593	ECA
90	M3GP 250 SMC	290	153	94.9	£7,151	£7,389	HO
110	M3GP 315 SMA	352	194	95.1	£10,892	£11,430	ECA
110	M3GP 280 SMC	353	185	95.7	£9,987	£10,309	HO,ECA
132	M3GP 315 SMB	423	228	95.4	£12,040	£12,580	ECA
160	M3GP 315 SMC	513	269	96.1	£13,762	£14,301	ECA
200	M3GP 315 MLA	641	336	96.3	£19,159	£19,697	ECA
250	M3GP 355 SMA	800	425	96.3	£24,244	£25,185	ECA
315	M3GP 355 SMB	1009	535	96.5	£30,515	£31,456	ECA
355	M3GP 355 SMC	1136	604	96.7	£34,417	£35,357	ECA
400	M3GP 355 MLA	1281	680	96.8	£38,483	£39,425	ECA
450	M3GP 355 MLB	1441	750	97.0	£43,907	£44,848	
500	M3GP 355 LKA	1601	830	97.0	£46,788	£47,729	
560	M3GP 355 LKB	1793	930	97.1	£52,552	£53,493	
560	M3GP 400 LA	1790	940	97.2	£55,094	£56,439	
560	M3GP 400 LKA	1790	940	97.2	£56,600	£57,945	
630	M3GP 400 LB	2014	1055	97.3	£61,196	£62,540	
630	M3GP 400 LKB	2014	1055	97.3	£62,702	£64,048	
710	M3GP 400 LC	2270	1185	97.4	£68,994	£70,338	
710	M3GP 400 LKC	2270	1185	97.4	£70,500	£71,844	

HO = High-output design ECA = ECA Compliant *Eff = Efficiency at full load 100%

Output kW	Frame Size	Torque Nm	Current I	Eff*	Foot Price	Flange Price	
1500 r/min = 2 poles							
0.25	M2BA 71 M4A	1.70	0.75	65.3	£243	£268	
0.37	M2BA 71 M4B	2.60	1.00	69.3	£258	£284	
0.55	M2BA 80 M4A	3.70	1.43	74.4	£274	£298	
0.75	M2BA 80 M4B	5.10	1.87	75.1	£289	£314	
1.1	M2BA 90 S4A	7.50	2.60	77.0	£325	£355	
1.5	M2BA 90 L4A	10.0	3.50	79.7	£363	£392	
2.2	M2BA 100 L4A	14.7	4.69	82.1	£414	£453	
3	M2BA 100 L4B	20.0	6.37	81.9	£472	£508	
4	M2BA 112 M4A	27.0	7.82	85.0	£576	£622	
5.5	M2BA 132 S4A	37.0	11.2	85.3	£698	£756	
7.5	M2BA 132 M4A	50.0	14.7	87.6	£859	£920	
11	M3GP 160 MLC	71.0	22.5	91.3	£1,215	£1,312	ECA
15	M3GP 160 MLE	98.0	30.0	92.0	£1,530	£1,625	ECA
18.5	M3GP 180 MLA	120	36.0	92.5	£1,768	£1,902	ECA
18.5	M3GP 160 MLF	120	36.5	92.3	£1,678	£1,774	HO,ECA
22	M3GP 180 MLB	143	42.0	92.6	£2,078	£2,213	ECA
22	M3GP 160 MLG	143	44.5	91.8	£1,947	£2,042	HO
30	M3GP 200 MLB	194	56.0	93.5	£2,701	£2,882	ECA
30	M3GP 180 MLC	194	59.0	92.3	£2,465	£2,599	HO
37	M3GP 225 SMB	239	69.0	93.6	£3,378	£3,588	ECA
37	M3GP 200 MLC	239	70.0	93.3	£3,109	£3,289	HO
45	M3GP 225 SMC	291	81.0	94.4	£3,960	£4,168	ECA
55	M3GP 250 SMA	355	101	94.6	£4,779	£5,017	ECA
55	M3GP 225 SMD	356	100	94.0	£4,646	£4,855	HO
60	M3GP 225 SME	387	110	94.0	£4,867	£5,075	HO
75	M3GP 280 SMA	483	135	94.9	£6,193	£6,515	ECA
75	M3GP 250 SMB	485	133	94.7	£6,201	£6,440	HO,ECA
90	M3GP 280 SMB	580	159	95.2	£7,433	£7,757	ECA
90	M3GP 250 SMC	556	155	94.9	£7,047	£7,285	HO
110	M3GP 315 SMA	706	193	95.6	£9,171	£9,710	ECA
110	M3GP 280 SMC	707	195	95.6	£8,475	£8,798	HO,ECA
132	M3GP 315 SMB	848	232	95.8	£10,833	£11,371	ECA
160	M3GP 315 SMC	1028	287	96.0	£12,660	£13,199	ECA
200	M3GP 315 MLA	1285	351	96.2	£17,995	£18,534	ECA
250	M3GP 355 SMA	1604	438	96.5	£21,251	£22,193	ECA
315	M3GP 355 SMB	2022	550	96.7	£28,231	£29,173	ECA
355	M3GP 355 SMC	2248	610	96.7	£30,093	£31,034	ECA
400	M3GP 355 MLA	2565	700	96.9	£34,124	£35,066	ECA
450	M3GP 355 MLB	2884	784	96.9	£38,622	£39,563	
500	M3GP 355 LKA	3204	875	97.0	£42,811	£43,751	
560	M3GP 400 LA	3587	980	97.0	£49,013	£50,358	
560	M3GP 400 LKA	3587	980	97.0	£49,013	£50,358	
630	M3GP 400 LB	4035	1085	97.0	£54,442	£55,787	
630	M3GP 400 LKB	4035	1085	97.0	£57,128	£58,472	
710	M3GP 400 LC	4352	1195	97.2	£64,416	£65,762	
710	M3GP 400 LKC	4352	1195	97.2	£65,924	£67,267	