

Supplementary Instructions for Installation of Draw-Rod Bushings Rated 25kV



Figure 1: Upper Section

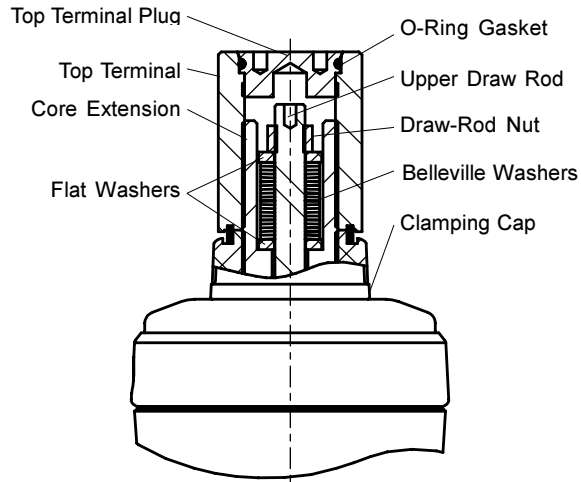

Figure 1: Center Section

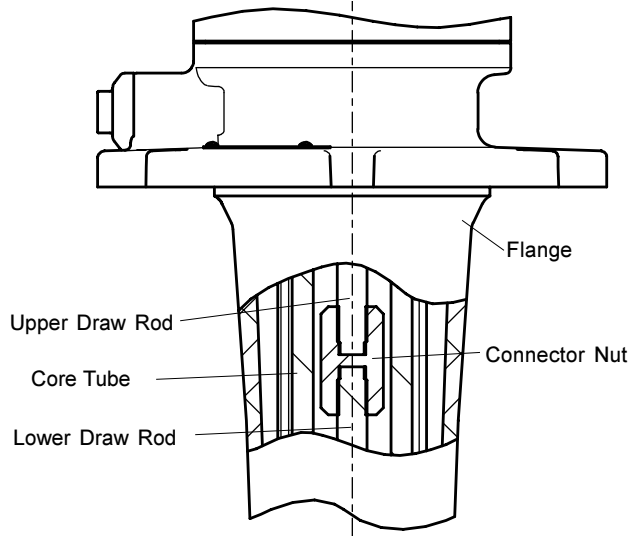

Figure 1: Lower Section

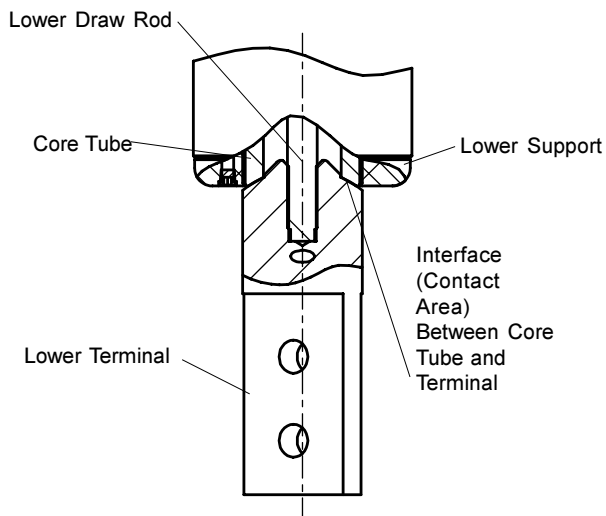
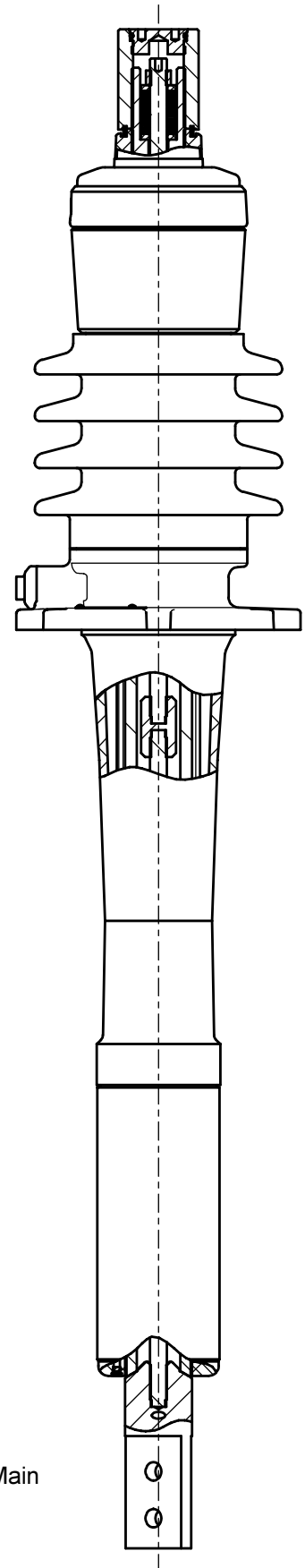

Figure 1: Main View



These instructions apply specifically to ABB Type O Plus C™ Draw-Rod Bushings rated 25 kV.

Refer to Instruction Leaflet 44-665 for installation and other general instructions.

The following tools/materials will be required for the assembly of this bushing.

1. Adjustable wrench
2. Adjustable face-pin type spanner wrench (Pin Dia. 0.25 inch or less.)
3. Curved-jaw locking pliers
4. Deep socket (15/16 inch across flats and 1.25 OD) with extension
5. Torque wrenches with 20 and 100 lb.-ft ranges or one wrench with 10 to 100 lb.-ft range
6. 15 feet of 16 or 14-gage steel wire
7. Draw-Rod assembly tool (# 8534A30H01; Supplied with the bushing)
8. Petroleum jelly

A. For Installation of bushing when received direct from ABB Power T&D Company Inc., Components Division, Alamo, TN.

1. The bushing is supplied from the factory completely assembled with the draw-rod assembly, and upper and lower terminals. Refer to the outline drawing for mounting, and other dimensions. See Figure 1 for other constructional features.
2. Refer to Instruction Leaflet 44-665 for installation and other general instructions.

B. Instructions for removal of bushing from the transformer after tests and prior to shipping to the site.

If the complete bushing, including the draw rod assembly, is to be removed for shipment, disconnect the transformer lead from the lower terminal and remove the bushing for shipment to the site.

If the transformer is to be shipped with the lower terminal and draw rod still connected to the transformer lead, use the following procedure for preparing the bushing for shipment to the site.

1. Using an adjustable face-pin type spanner wrench, unscrew and remove the top terminal plug.
2. Using a deep socket, loosen the draw-rod nut to free up the lower terminal. Do not unscrew the draw-rod nut completely.

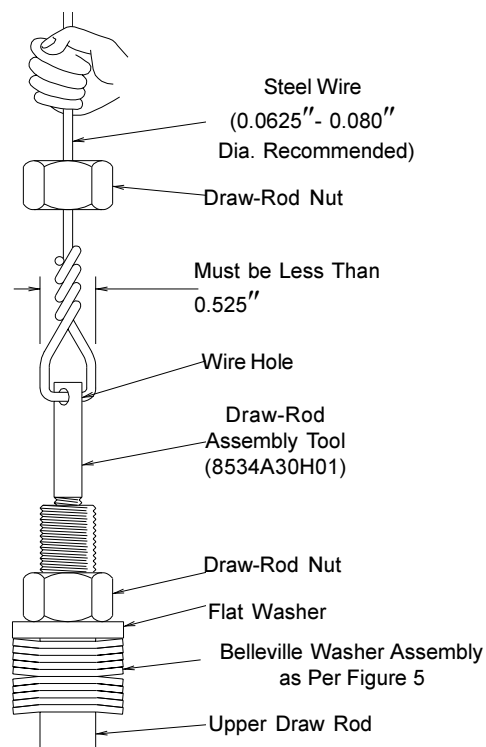

Figure 2: Assembly of Draw-Rod Nut Over the Draw Rod

3. Screw the draw-rod assembly tool into the tapped hole at the top end of the upper draw rod until it bottoms as shown in Figure 2. Through the wire hole provided, tie a 15 ft. long 16 or 14 gage wire to the top end of the draw-rod assembly tool as shown in Figure 2. Pass the other end of the wire through the socket and slide the socket down to engage the nut.

While pulling the wire, unscrew the draw-rod nut completely to free up the draw-rod assembly. Hold the wire to support the draw-rod assembly. Remove the draw-rod nut and the deep socket.

WARNING

If the nut is not completely removed in step B3, the transformer lead will be damaged while removing the bushing from the transformer.

4. Unbolt the bushing mounting flange and remove the bushing while holding the wire to support the draw-rod assembly in place in the transformer. Make sure the Belleville washer assembly is not disturbed during the above process.

Keep the bushing in the upright position so as not to disturb the Belleville washers inside the top terminal / core extension. Remove the wire and unscrew the draw-rod assembly tool, while holding the draw-rod assembly in place.

- Using curved-jaw locking pliers, unscrew the upper draw rod from the connector nut, while holding the connector nut in place with an adjustable wrench.

WARNING

Care should be taken to support the lower draw rod during the above procedure; otherwise it will fall into the transformer.

- Secure the lower draw rod for shipping using one of the methods shown in Figure 3. While these methods are shown here as suggestions of how to support the lower draw rod during shipping, the transformer manufacturer may elect to use another method.
- Place the remaining section of the draw rod into the bushing for shipment as follows: screw the draw-rod nut onto the top of the draw rod just enough to completely engage the nut threads. Tie cotton tape around the draw rod and the nut so that the nut does not come off during shipping.
- Insert the other end of the draw rod into the conductor tube through the Belleville washer assembly until the

draw-rod nut comes to rest on top of the Belleville washer assembly.

- Apply a light coat of petroleum jelly on the O-ring gasket in the top terminal plug. Screw the plug in place and firmly tighten it with an adjustable face-pin type spanner wrench.
- The bushing is now ready for shipment to the site. Refer to Instruction Leaflet 44-665 for handling and other instructions. Ship the draw-rod assembly tool with the bushing.

C. Instructions for installation of bushing at the site when the bushing was shipped from the transformer factory after tests.

If the bushing was shipped complete with the lower terminal and the draw-rod assembly, and these parts have not been disturbed since the bushing was manufactured, then install the bushing as per Step A.

If the bushing was shipped without the lower terminal/draw-rod assembly as per Step B, then use the following procedure to install the bushing. Refer to Instruction Leaflet 44-665 for handling and other instructions.

- Using the appropriate procedure, remove the bushing from the shipping crate and hang it upright from the crane.
- Using an adjustable face-pin type spanner wrench, unscrew and remove the top terminal plug.

Figure 3.A.

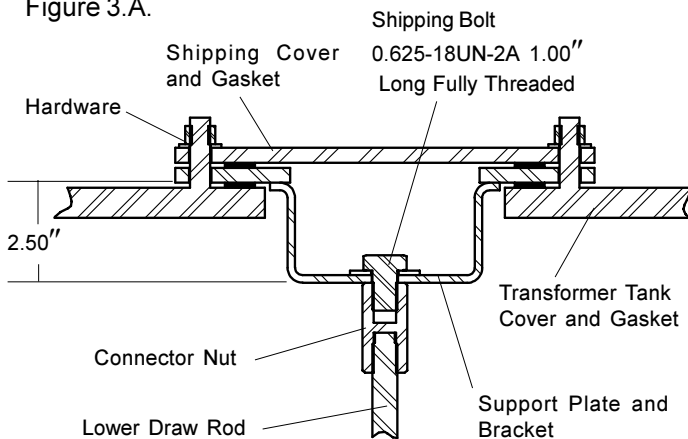

Note: other than dimensions specified, the detailed design is left to the transformer manufacturer.

Figure 3.B.

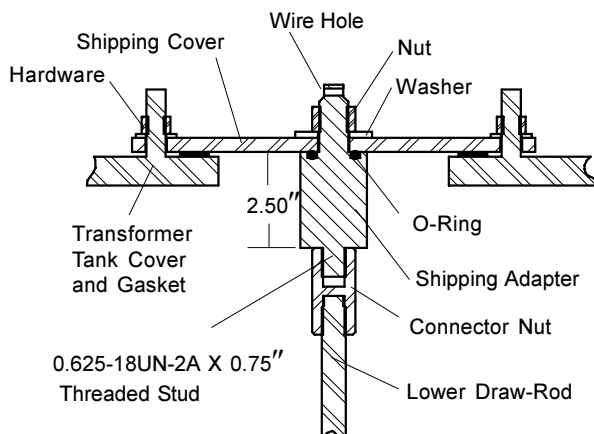

Note: other than dimensions specified, the detailed design of the shipping adapter is left to the transformer manufacturer.

Figure 3: Methods of Support for Shipping.

3. Screw the draw-rod assembly tool into the top end of upper draw rod. Remove the upper draw rod by holding on to the draw-rod assembly tool. Make sure the Belleville washer assembly is not disturbed while removing the upper draw rod. Remove the cotton tape and the draw-rod nut from the upper draw rod.
4. Apply petroleum jelly on the threads of upper draw rod and the draw-rod nut.
5. Unbolt and remove the shipping cover as shown in Figure 3. If the method in figure 3.B. is used, support the lower draw-rod assembly with a wire passed through the hole in the shipping adapter. While holding the connector nut with an adjustable wrench, carefully unscrew and remove the draw-rod shipping bolt or adapter. Remove any remaining shipping hardware. Refer to the transformer Instruction Book for more detailed information.

WARNING

Be careful not to drop the shipping hardware into the transformer tank. Care should be taken to support the lower draw rod during the above procedure; otherwise it will fall into the transformer.

6. Screw the upper draw rod into the connector nut. Using curved-jaw locking pliers, firmly tighten the upper draw rod into the connector nut while holding the connector nut in place with an adjustable wrench. The upper draw rod must bottom into the connector nut.

The connector nut and the lower terminal are permanently attached to the lower draw rod.
7. Install the bushing mounting flange gasket.
8. While hanging the bushing upright from the crane over the mounting area and above the draw rod, insert a 15 ft. long 16 or 14 gage steel wire into the tube through the Belleville washer assembly until it comes out of the conductor tube at the bottom end.
9. Through the wire hole provided, tie this end of the wire to the top end of the draw-rod assembly tool as shown in Figure 2.
10. While supporting the wire and the draw-rod assembly, slowly lower the bushing over the draw rod until the top end of the draw rod passes through all washers in the Belleville washer assembly as shown in Figure 2.
11. While firmly supporting the wire and the draw-rod as-

sembly, slide the draw-rod nut and the socket down over the wire and assembly tool, and hand tighten the nut on the draw rod as shown in Figure 2. Do not tighten the nut at this point. The purpose of screwing the nut on at this point is to prevent the draw rod from falling/sliding down. Remove the wire and the draw-rod assembly tool from the upper end of the draw rod.

12. Using the appropriate procedure, finish mounting the bushing.
13. Install the deep socket over the draw-rod nut. Tighten the draw-rod nut with 10 lb.-ft torque. This is just to seat all the parts together; the final tightening is done as follows. Mark the angular position of the deep socket with respect to the top terminal. Tighten/turn the draw-rod nut in the clockwise direction an additional 1.5 turns. This should take between 55 and 70 lb.-ft torque. If the torque is more than 70 lb.-ft then please contact ABB, Alamo, TN for further information.

WARNING

Do not turn the nut more than the nominal 1.5 turns as it will overtighten and can damage the draw-rod assembly and cause personal injury.

14. Apply a light coat of petroleum jelly on the O-ring gasket in the top terminal plug. Screw the plug in place and firmly tighten it with an adjustable face-pin type spanner wrench.
15. The installation of the draw-rod assembly is now complete.

D. Instructions for removal and replacement of bushing at the site.

The following procedure will apply when a draw-rod bushing is to be removed at the site and replaced with another bushing of the same style.

1. Using an adjustable face-pin type spanner wrench, unscrew and remove the top terminal plug from the old bushing.
2. Using a deep socket, loosen the draw-rod nut to free up the lower terminal. Do not remove the draw rod-nut completely.
3. Screw the draw-rod assembly tool into the tapped hole at the top end of the upper draw rod until it bottoms as shown in Figure 2. Through the wire hole provided, tie a 15 ft. long 16 or 14 gage steel wire to the top end of

the draw-rod assembly tool as shown in Figure 2. Pass the other end of the wire through the socket and slide the socket down to engage the nut.

While pulling the wire, unscrew the draw-rod nut completely to free up the draw-rod assembly. Hold the wire to support the draw-rod assembly. Remove the deep socket and the draw-rod nut.

WARNING

If the nut is not completely removed in step D3, the transformer lead will be damaged while removing the bushing from the transformer.

- 4. Unbolt the old bushing at the mounting flange and remove the bushing while holding the wire to support the draw-rod assembly in place in the transformer. Keep the bushing in the upright position so as not to disturb the Belleville washer assembly inside the top terminal. Stand the bushing upright on a rack. Remove the wire from the upper end of the draw rod while holding the draw rod in place.
- 5. Using curved-jaw locking pliers, firmly tighten the upper draw-rod into the connector nut while holding the connector nut in place with an adjustable wrench. The upper draw rod must bottom into the connector nut.

If the old draw-rod assembly parts are damaged, disconnect the entire assembly at the transformer lead and replace it with new parts from the replacement bushing. This should not normally be required.

- 6. Hang the replacement bushing upright from the crane.
- 7. Using an adjustable face-pin type spanner wrench, unscrew and remove the top terminal plug.
- 8. Using a deep socket, unscrew and completely remove the draw-rod nut while supporting the lower terminal/draw-rod assembly firmly in place. If the upper draw rod unscrews at the connector nut, then remove it by pulling it from the top. Make sure the Belleville washer assembly is not disturbed during this process.

WARNING

Unscrewing the draw-rod nut will free up the entire draw-rod assembly. This assembly weighs about 12 lb. and care should be taken to support it firmly in place; otherwise it will fall/slide down and can cause personal injury.

- 9. Raise the bushing and remove the draw-rod/lower terminal assembly. Save this draw-rod assembly along with the old bushing. Make sure the Belleville washer assembly in the new bushing is not disturbed during the above process.
- 10. While hanging the new bushing upright from the crane over the mounting area, and above the draw-rod assembly, insert the 15 ft. long 16 or 14 gage steel wire into the tube through the Belleville washer assembly until it comes out of the conductor tube at the bottom end. Through the hole provided, tie this end of the wire to the top end of draw-rod assembly tool as shown in Figure 2.
- 11. While supporting the wire and the draw-rod assembly, slowly lower the bushing over the draw rod until the top end of draw rod passes through all washers in the Belleville washer assembly as shown in Figure 2.
- 12. Apply petroleum jelly on the threads of the upper draw rod and the draw-rod nut.
- 13. While firmly supporting the wire and the draw-rod assembly, slide the draw rod nut and the socket down over the wire and assembly tool, and hand tighten the nut on the draw rod as shown in Figure 2. Do not tighten the nut at this point.
- 14. Remove the wire and the draw-rod assembly tool from the upper end of the draw rod.
- 15. Using the appropriate procedure, mount the bushing on the transformer tank.
- 16. Install the deep socket over the draw-rod nut. Tighten the draw-rod nut with 10 lb.-ft torque. This is just to seat all the parts together; the final tightening is done as follows. Mark the angular position of the deep socket with respect to the top terminal. Tighten/turn the draw-rod nut in the clockwise direction an additional 1.5 turns. This should take between 55 and 70 lb.-ft torque. If the torque is more than 70 lb.-ft then please contact ABB, Alamo, TN for further information.

WARNING

Do not turn the nut more than the nominal 1.5 turns as it will overtighten and may damage the draw-rod assembly and may cause personal injury.

- 17. Apply a light coat of petroleum jelly on the O-ring gasket in the top terminal plug. Screw the plug in place

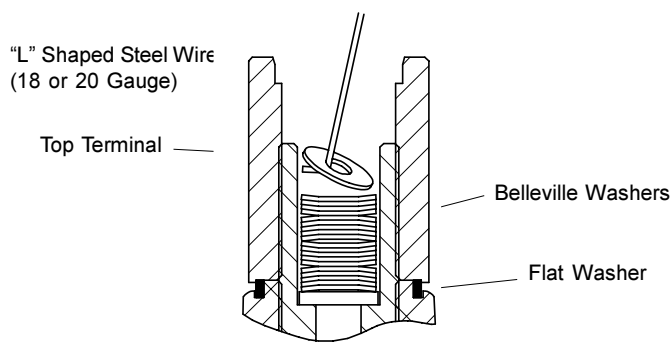

Figure 4: Removal of Belleville Washers

and firmly tighten it with an adjustable face-pin type spanner wrench.

18. The installation of the draw-rod assembly is now complete.

E. Reassembly of Belleville and flat washers.

This procedure is to be used only if, at any time, the Belleville washers' orientation has been disturbed, and they require rearranging.

1. Remove all the washers from the top terminal/core extension using an "L" shaped wire as shown in Figure 4.

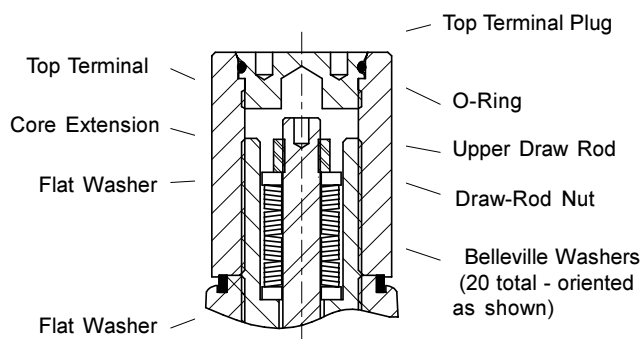

Figure 5: Belleville Washer Assembly

2. Rearrange/assemble the Belleville and flat washers as shown in Figure 5. The assembly of the washers can be simplified by inserting a 0.625 inch Dia. (Max.), 2 foot long rod into the top terminal/core extension and assembling the washers over the rod while holding the rod in place as shown in Figure 6. After all the washers are in place, remove the rod.

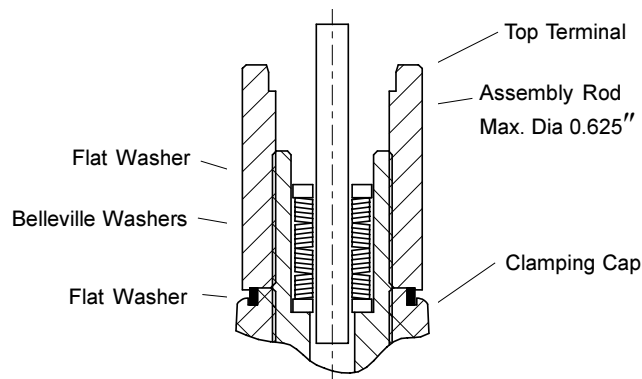

Figure 6: Assembly of Belleville Washers using a Rod.

WARNING

The orientation of the Belleville and other washers is very critical for proper operation. Failure to follow the proper orientation will result in overheating/failure of the bushing and the transformer. Do not drop the rod into the conductor tube as it will slide down through the tube and can cause personal injury.

3. Follow the appropriate tightening procedure above.

Maintenance

For general maintenance, refer to Instruction Leaflet 44-665.

The top terminal of this bushing is permanently attached and does not need any tightening.

If at any time the draw-rod nut is unscrewed, the proper tightening procedure given in Section C must be followed to insure the tightness of the draw-rod/lower terminal assembly.

Replace the top terminal plug O-ring if any damage is observed.

Under normal circumstances there is no need to replace the Belleville washers. If there is a need to replace these washers, they should be ordered from ABB. Do not use washers other than those supplied by ABB, Alamo, TN.

WARNING

The tightness of the draw-rod assembly and the top end parts is very critical for proper operation. Failure to follow the proper tightening procedure may result in overheating/failure of the bushing and the transformer.

Renewal Parts

If renewal parts are required, order them through the nearest ABB Power T&D Company Inc. representative. Please provide the item description and the identification numbers (model, style, catalog) from the unit's nameplate.

Technical Support

If a technical question arises regarding the product detailed in this Technical Product Literature contact:

ABB Power T&D Company Inc.
Components Division
1128 Highway 412 S.
Alamo, TN 38001 USA

Phone: (800) 955-8399
(901) 696-5561
Fax: (901) 696-5269

Comments

ABB Power T&D Company Inc. continually strives to make its instruction literature current, accurate, and easy to understand. Suggestions to improve this document may be sent to: Literature Coordinator fax (901) 696-5269 or use the mailing address at the bottom of this page. For a reply, please include name, company, phone number, and/or fax number.

DISCLAIMER OF WARRANTIES AND LIMITATION OF LIABILITY

THERE ARE NO UNDERSTANDINGS, AGREEMENTS, REPRESENTATIONS, OR WARRANTIES, EXPRESSED OR IMPLIED, INCLUDING WARRANTIES OF MERCHANTABILITY OR FITNESS FOR A PARTICULAR PURPOSE OTHER THAN THOSE SPECIFICALLY SET OUT BY AN EXISTING CONTRACT BETWEEN THE PARTIES. ANY SUCH CONTRACT STATES THE ENTIRE OBLIGATION OF SELLER. THE CONTENTS OF THIS DOCUMENT SHALL NOT BECOME PART OF OR MODIFY ANY PRIOR OR EXISTING AGREEMENT, COMMITMENT, OR RELATIONSHIP.

The information, recommendations, description, and safety notations in this document are based on our experience and judgement. **THIS INFORMATION SHOULD NOT BE CONSIDERED TO BE ALL INCLUSIVE OR COVERING ALL CONTINGENCIES.** If further information is required, ABB Power T&D Company Inc. should be consulted.

NO WARRANTIES, EXPRESSED, OR IMPLIED, INCLUDING WARRANTIES OF FITNESS FOR A PARTICULAR PURPOSE OR MERCHANTABILITY, OR WARRANTIES ARISING FROM COURSE OF DEALING OR USAGE OF TRADE, ARE MADE REGARDING THE INFORMATION, RECOMMENDATIONS, DESCRIPTIONS AND SAFETY NOTATIONS CONTAINED HEREIN. In no event will ABB Power T&D Company Inc. be responsible to the user in contract, in tort (including negligence), strict liability or otherwise for any special, indirect, incidental or consequential damage or loss whatsoever including but not limited to damage to or loss or use of equipment, plant or power system, cost of capital, loss of profits or revenues, cost of replacement power, additional expenses in the use of existing power facilities, or claims against the user by its customers resulting from the use of the information, recommendations, description, and safety notations contained herein.

