

Standard Digital Indicator ABS Digimatic Indicator ID-C

Bulletin No. 1966



Digital indicators offer dramatically improved readability, usability and functionality

Mitutoyo

Digital indicators that offer dramatically improved ease of ABS Digimatic Indicator ID-C

The Nakatsugawa plant is in the central industrial park of beautiful Nakatsugawa city, in the Gifu prefecture. This plant specializes in manufacturing sensor products and handles the complete development-to-production cycle for measuring instruments such as dial gages, test indicators, Digimatic indicators, and bore gages. It was opened in 1997 as the 12th Mitutoyo plant in Japan. Using its state-of-the-art production techniques and facilities, this plant continues to provide Mitutoyo products that are praised around the world and used with confidence.



543-392B

ABSOLUTE®



543-472B

ABSOLUTE®



543-492B

ABSOLUTE®



ABS Digimatic indicator ID-C is a standard digital indicator. A large LCD incorporating 11mm characters (existing products: 8.5mm) is used to improve visibility, and three large, easy-to-press buttons are used in the design to make operations easier to perform. In addition, this affordable product has various measurement functions, including the ability to perform scaling calculations, judge tolerance, hold data, and perform general comparison measurements.

Examples of use



reading measurement values, usability and functionality

1. Large LCD

The large LCD incorporates 11mm characters giving 1.5 times the character area of existing products (which display 8.5mm characters) making measurement values much easier to read.

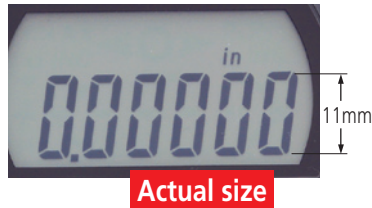

Actual size

2. Three large buttons

The popular three-large-button design, which is used in products such as the ABS coolant proof Digimatic indicator ID-N/ID-B, makes buttons easier to press and operations easier to perform.

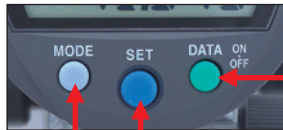

Parameter setting mode

Count direction switching, tolerance judgment setting, resolution switching, scale factor setting, and function lock setting

- Power switch
- Data output (when connected to an external device)
- Data hold (when no external device is connected)

- Switches between the ABS (preset) and INC (zeroset) measurement modes

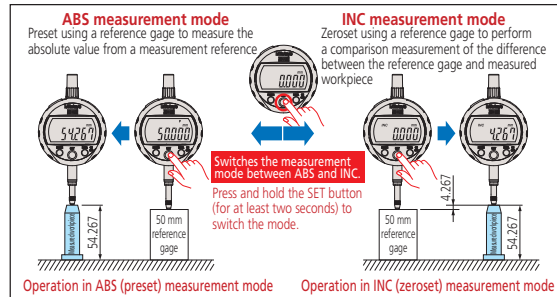

3. Expanded lifting capability

The lifting function that moves the spindle up and down has been expanded to improve work efficiency when using the ID-C mounted on a stand.

For models that have a 12.7mm measuring range, a lifting lever (special accessory) can be mounted on the left or right side, improving work efficiency and smoothness of movement.



A lifting cable (special accessory) provides a maximum of approximately 25.4mm of spindle movement (twice that of existing models). So for models that have a 12.7mm or 25.4mm measuring range, the spindle can be moved through the entire measuring range. (Applied to models that have a 50.8mm measuring range, the spindle can be retracted by approximately 25.4mm from the extended position.)



Lifting knob (special accessory)



By using a lifting knob (special accessory) fitted to the top of the spindle, you can perform full-stroke operation without directly touching the spindle.

Lifting lever (finger hook)

Standard accessory (only for models that have a measuring range of 25.4mm or 50.8mm)

If dust or coolant gets into the gap between the spindle and main unit while using the lifting knob, the spindle travel may become rough or the indicator may fail altogether. Therefore avoid using the ID-C in environments containing dust or coolant mist.

4. Functions that support measurement

The ID-C has various functions, including the ability to hold data, output data, switch the measuring direction, judge tolerance, change the scale factor, and a lock to prevent misoperation. (For details, see page 6.)



Measurement value and tolerance judgment



Enlarged display of the tolerance judgment result

5. 330° rotary display

The display can be rotated 330°, allowing use at a position where you can easily read the measurement value.

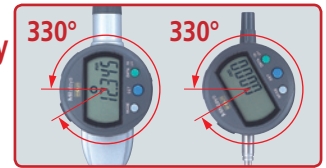

6. Application products for one-touch quick measurement

Various application products are available that enable you to perform one-touch quick measurement of the thickness of small parts, papers, felt, lenses, and pipes, as well as the depth of narrow grooves on cylindrical workpieces, groove depth, and steps. (For details, see pages 8-11.)

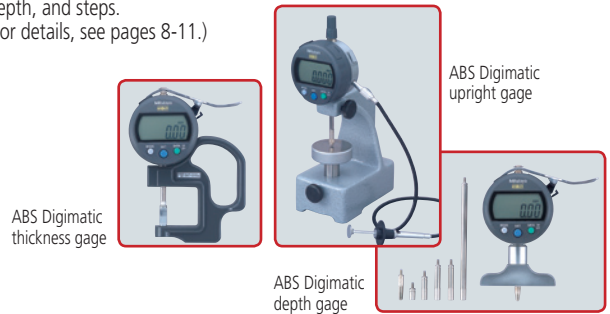

7. The ABS (ABSOLUTE) sensor

The original Mitutoyo ABS (ABSOLUTE) sensor, which is capable of relocating the origin even after turning the power off, enables you to quickly start multi-point measurement. Also, the ABS measurement mode can be restored even after measurement in the INC mode, where zerosetting is possible at any position, improving work efficiency.



8. Inspection certificate provided as standard

Mitutoyo provides an inspection certificate that includes inspection data as standard to guarantee that every product shipped is of high quality and safe to use. Upon request, we can also calibrate purchased measuring instruments and issue a calibration certificate that proves traceability to national (or international) standards for a fee. To minimize calibration uncertainty as much as possible, both the inspection certificate and calibration certificate are issued after measurement using dedicated testers developed with advanced Mitutoyo measurement technologies. Note that the inspection certificate cannot be used to obtain a calibration certificate because the former does not indicate the date of purchase.

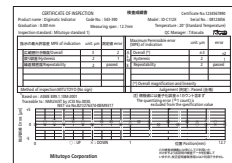

ABS Digimatic Indicator ID-C

SPECIFICATIONS

Inch/Metric ISO/JIS Type and ANSI/AGD Type

Order No.	Measuring range	Accuracy**†1	Hysteresis*	Repeatability*	Measuring force	Mass	Remarks	
Resolution .0005"/.0001"/.0005"/0.001mm/0.01mm								
543-391	543-391B	.5"	±.00010"/0.003mm	.00010"/0.002mm	.00010"/0.002mm	1.5N or less	170g	—
543-392	543-392B	.5"	±.00010"/0.003mm	.00010"/0.002mm	.00010"/0.002mm	1.5N or less	170g	—
543-395	543-395B	.5"	±.00010"/0.003mm	.00010"/0.002mm	.00010"/0.002mm	0.7, 0.6, 0.4N or less	170g	Low measuring force
543-396	543-396B	.5"	±.00010"/0.003mm	.00010"/0.002mm	.00010"/0.002mm	0.7, 0.6, 0.4N or less	170g	Low measuring force
—	543-471B	1"	±.00010"/0.003mm	.00010"/0.002mm	.00010"/0.002mm	1.8N or less	190g	—
—	543-472B	1"	±.00010"/0.003mm	.00010"/0.002mm	.00010"/0.002mm	1.8N or less	190g	—
—	543-491B	2"	±.00020"/0.005mm	.00010"/0.002mm	.00010"/0.002mm	2.3N or less	260g	—
—	543-492B	2"	±.00020"/0.005mm	.00010"/0.002mm	.00010"/0.002mm	2.3N or less	260g	—
Resolution .0005"/0.01mm								
543-401	543-401B	.5"	±.0010"/0.02mm	.0010"/0.02mm	.0005"/0.01mm	0.9N or less	170g	—
543-402	543-402B	.5"	±.0010"/0.02mm	.0010"/0.02mm	.0005"/0.01mm	0.9N or less	170g	—
543-405	543-405B	.5"	±.0010"/0.02mm	.0010"/0.02mm	.0005"/0.01mm	0.5, 0.4, 0.3, 0.2N or less	170g	Low measuring force
543-406	543-406B	.5"	±.0010"/0.02mm	.0010"/0.02mm	.0005"/0.01mm	0.5, 0.4, 0.3, 0.2N or less	170g	Low measuring force
—	543-475B	1"	±.0010"/0.02mm	.0010"/0.02mm	.0005"/0.01mm	1.8N or less	190g	—
—	543-476B	1"	±.0010"/0.02mm	.0010"/0.02mm	.0005"/0.01mm	1.8N or less	190g	—
—	543-495B	2"	±.0015"/0.04mm	.0010"/0.02mm	.0005"/0.01mm	2.3N or less	260g	—
—	543-496B	2"	±.0015"/0.04mm	.0010"/0.02mm	.0005"/0.01mm	2.3N or less	260g	—

Metric ISO/JIS Type

Order No.	Measuring range	Accuracy**†1	Hysteresis*	Repeatability*	Measuring force	Mass	Remarks	
Resolution 0.001mm/0.01mm								
543-390	543-390B	12.7mm	0.003mm	0.002mm	0.002mm	1.5N or less	170g	—
543-394	543-394B	12.7mm	0.003mm	0.002mm	0.002mm	0.7, 0.6, 0.4N or less	170g	Low measuring force
—	543-470B	25.4mm	0.003mm	0.002mm	0.002mm	1.8N or less	190g	—
—	543-490B	50.8mm	0.005mm	0.002mm	0.002mm	2.3N or less	260g	—
Resolution 0.01mm								
543-400	543-400B	12.7mm	0.02mm	0.02mm	0.01mm	0.9N or less	170g	—
543-404	543-404B	12.7mm	0.02mm	0.02mm	0.01mm	0.5, 0.4, 0.3, 0.2N or less	170g	Low measuring force
—	543-474B	25.4mm	0.02mm	0.02mm	0.01mm	1.8N or less	190g	—
—	543-494B	50.8mm	0.04mm	0.02mm	0.01mm	2.3N or less	260g	—

□ : ANSI/AGD Type

Note) Products with an Order No. suffixed "B" have a flat back, and other models have a back with a lug.

* Overall hysteresis and repeatability specifications are valid for normal measurement at 20°C, and the quantizing error of ±1 count is excluded.

COMMON SPECIFICATIONS

- Display: 6-digit LCD, sign
- Contact point: Spherical tip SR = 1.5mm (carbide tipped), part No. 901312 (for ISO/JIS Type) part No. 21BZB005 (for ANSI/AGD Type)
- Spindle orientation for measurement:
 - Standard model that has a 12.7mm measuring range: No restrictions
 - Standard model that has a 25.4mm or 50.8mm measuring range: Normally at any position between the spindle pointing vertically downward to the spindle horizontal. To perform measurement with the spindle pointing above the horizontal requires a reverse-position coil spring (special accessory).
 - Low measuring force models: See 'Setting measuring force on low measuring force models' on page 5.
- Position detection method: Capacitance type absolute linear encoder
- Battery: SR44 (silver oxide button cell) × 1, part No. 938882
- Battery life: Approximately 7,000 hours of continuous use
- Maximum response speed: Not restricted (except for scanning measurement)
- Service temperature range: 0 to 40°C
- Storage temperature range: 0 to 60°C

Setting measuring force on low measuring force models

•543-404/404B/405/405B/406/406B

Spindle orientation	Spring	Weight (approximately 0.1 N)	Maximum measuring force
Pointing vertically downward	Yes	Yes	0.5N
	Yes	No	0.4N
	No	Yes	0.3N
	No	No	0.2N
Horizontal	Yes	No	0.2N

Note) Operation using configurations other than shown above is not guaranteed.

•543-394/394B/395/395B/396/396B

Spindle orientation	Spring	Weight (approximately 0.1 N)	Maximum measuring force
Pointing vertically downward	Yes	Yes	0.8N (0.3+0.4+0.1=0.8)
	Yes	No	0.6N
	No	Yes	0.4N
	No	No	Not guaranteed
Horizontal	Not guaranteed		

Note) Operation using configurations other than shown above is not guaranteed.

DIMENSIONS

ISO/JIS Type

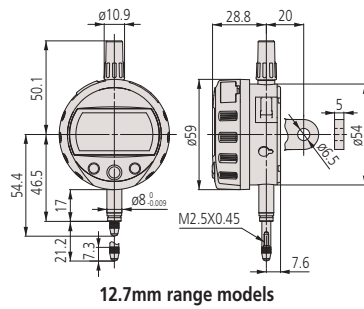

12.7mm range models

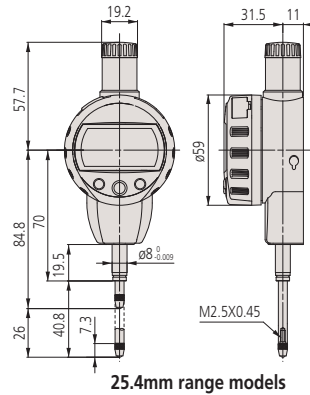

25.4mm range models

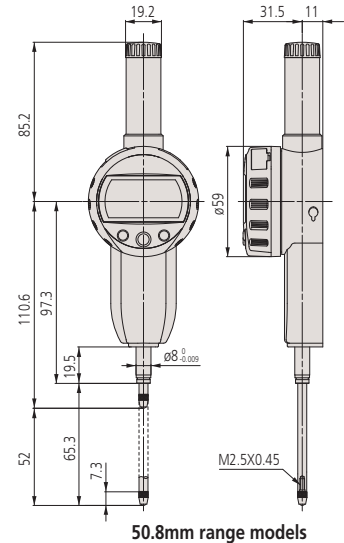

50.8mm range models

ANSI/AGD Type

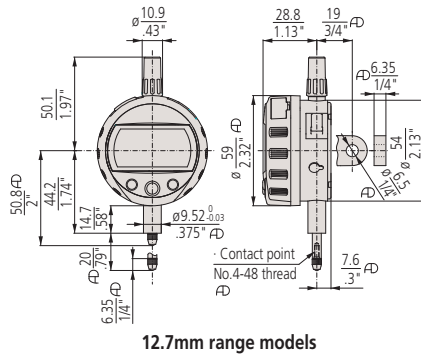

12.7mm range models

* ϕ D is the symbol denoting American Gage Design (AGD). It shows conformance to certain dimensions for Dial Indicators, as specified in ASME / AGD 2, intended to promote interchangeability. Only applicable to models with an "E" suffix.

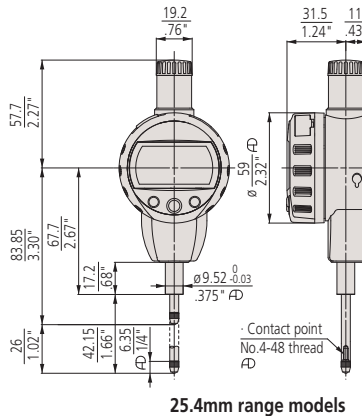

25.4mm range models

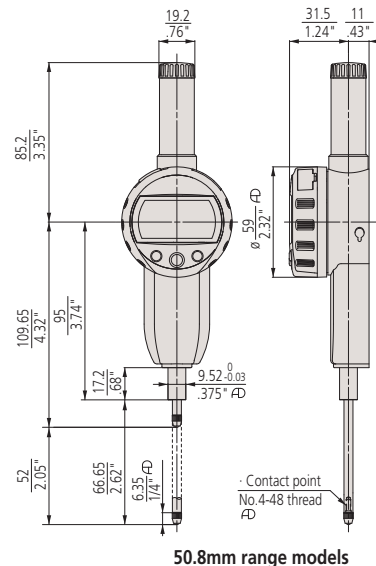

50.8mm range models

Functions and accessories

Functions

- Zero-setting function (INC measurement mode)
- Preset function (ABS scale origin setting)

The preset value can be changed easily by using the SET (digit movement) and MODE (value change) buttons.



- Switching the direction

The measuring direction can be reversed.

- Judging the tolerance

Performs judgment (OK, +NG, -NG) according to the set upper and lower limit values and displays the result as a symbol. Enlarged display of the OK and NG symbols is possible.



Measurement value and tolerance judgment

Enlarged display of the tolerance judgment result

- 330° rotary display

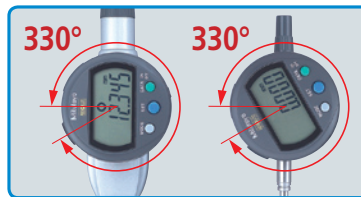

- Resolution switching (For 0.001mm or .00005" resolution models)

Models with 0.001mm resolution are capable of displaying in 0.01mm resolution. Models with .00005" resolution are capable of displaying in .0001" and .0005" resolution. Select the resolution according to the application.



- Display value holding (when no external device is connected)



- Calculation: $f(x) = Ax$

Mounting the ID-C on a measuring jig and setting the calculation factor (to any value) allows direct measurement without using a conversion table and improves measurement efficiency.

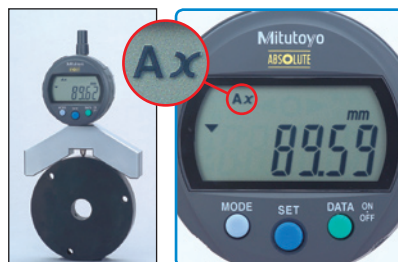

- Data output (when connected to an external device)

From the output terminal, measurement data can be output to a PC via a compact printer, Digimatic mini processor DP-1VR, or input tool by pressing the button below the display. Wireless transmission of measurement data to a PC can also be performed using the measurement data wireless communication system U-WAVE.

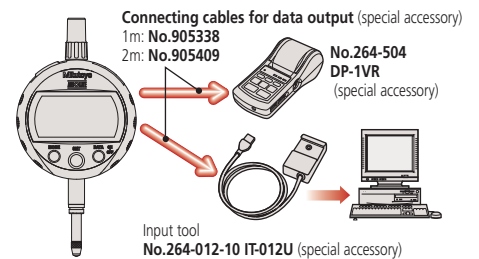

- Function locking

Ensures reliability of measurement by locking the settings to prevent preset function settings from being changed by mistake.



- Low battery voltage alarm
- Error alarm

Standard accessories

- Operation manual
- Inspection certificate
- ① Lifting lever (finger hook)
(Only for models that have a 25.4mm or 50.8mm measuring range)
- Silver oxide button cell for the monitor: SR44 × 1
Part No. 938882
- Weight (only for low measuring force models)

Special accessories

- ② Lifting lever
Part No. 21EZA198
(for models that have a 12.7mm measuring range ISO/JIS Type)
Part No. 21EZA199
(for models that have a 12.7mm measuring range ANSI/ADG Type)
- ③ Lifting cable, part No. 540774
- ④ Lifting knob
Part No. 21EZA105
(for models that have a 12.7mm measuring range ISO/JIS Type)
Part No. 21EZA150
(for models that have a 12.7mm measuring range ANSI/ADG Type)
Part No. 21EZA197
(for models that have a 25.4mm measuring range)
Part No. 21EZA200
(for models that have a 50.8mm measuring range)

- Interchangeable contact points for Mitutoyo dial gages

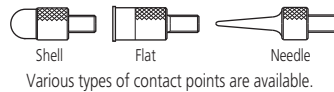

- Various backs for standard Mitutoyo (2 series) dial gages
- Reverse-position coil spring
Part No. 02ACA571
(for models that have a 25.4mm measuring range)
Part No. 02ACA773
(for models that have a 50.8mm measuring range)
- Connecting cable (1m), part No. 905338
- Connecting cable (2m), part No. 905409

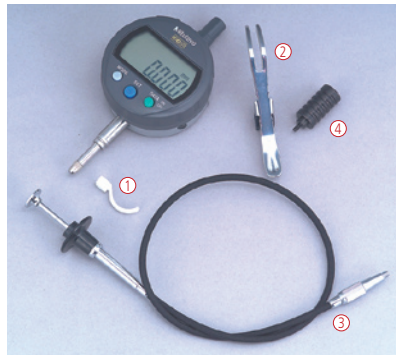

- U-WAVE
(measurement data wireless communication system)
- Digimatic mini processor DP-1VR No. 264-504
- Multiplexer MUX-10F, No. 264-002
- Display unit EC-101D, No. 542-007
- Input tool (USB keyboard signal conversion type)
IT-012U, No. 264-012-10



- Recommended stands
- ⑤ Dial gage stand, No. 7001 7002 7007
- ⑥ Granite comparator stand BSG-30, No. 215-154
- ⑦ Comparator stand BSC-30, No. 215-504
- ⑧ Comparator stand BSG-20, No. 215-151



Various Digimatic Indicators

- ① **ID-C**: Standard Digital Indicator
- ② **ID-N/B**: waterproof, 35mm slim body with various functions
- ③ **ID-H**: infrared remote controller, high accuracy, and various functions
- ④ **ID-S**: cost-effective type that has basic functions
- ⑤ **ID-U1025**: general-purpose type that has a 25.4mm measuring range
- ⑥ **ID-C112RB**: has a built-in calculation function
- ⑦ **ID-C112A**: has a peak hold function
- ⑧ **ID-C112GB**: internal diameter measuring instrument dedicated to cylinder gages

Application Products

ABS Digimatic Thickness Gage



547-300S



547-320S



547-400S

Unit: mm

- For one-touch quick measurement of the thickness of small parts, papers, and felt
- Rust-free ceramic contact point and anvil (except No. 547-401)

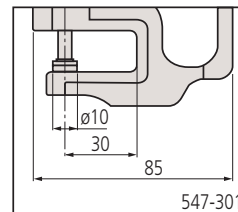

547-301

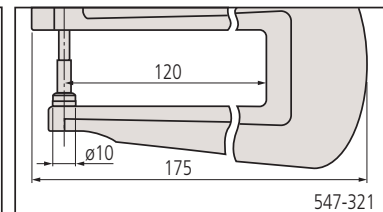

547-321

Inch/Metric ANS/AGD Type

Order No.	Resolution	Measuring range	Throat depth	Contact point and anvil	Parallelism of contact point and anvil	Accuracy	Measuring force
547-300S	.0005"/0.01mm	0~.4"/0~10mm	30mm	10mm flat	.0005" or less	±.001"	1.5N or less
547-320S	.0005"/0.01mm	0~.4"/0~10mm	120mm	10mm flat	.0005" or less	±.001"	1.5N or less
547-400S	.00005"/0.001mm	0~.47"/0~12mm	21mm	6.3mm flat (carbide tipped)	.0001" or less	±.0001"	3.5N or less

Metric ISO/JIS Type

Order No.	Resolution	Measuring range	Throat depth	Contact point and anvil	Parallelism of contact point and anvil	Accuracy	Measuring force
547-301	0.01mm	0~10mm	30mm	10mm flat	10μm or less	±20μm	1.5N or less
547-321	0.01mm	0~10mm	120mm	10mm flat	10μm or less	±20μm	1.5N or less
547-401	0.001mm	0~12mm	21mm	6.3mm flat (carbide tipped)	3μm or less	± 3μm	3.5N or less

- Note) 1. Changing the contact point requires total adjustment, including the main display unit. Contact Mitutoyo for advice.
 2. The accuracy specification does not include the quantizing error of ±1 count.
 3. Left-handed models can be supplied to special order.

ABS Digimatic Lens Meter



547-312S

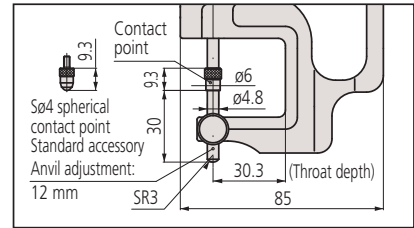
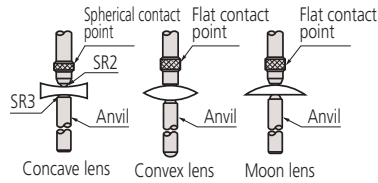

Unit: mm

- Designed for measuring the thickness of concavo-convex lenses and flat objects
- The thickness of flat objects can be measured by replacing the anvil.
- Includes a spherical contact point.

Inch/Metric ANSI/AGD Type

Order No.	Resolution	Measuring range	Throat depth	Anvil adjustment	Accuracy	Measuring force
547-312S	.0005"/0.01mm	0~.4"/0~10mm	30mm	12mm	±.001" or less	1.5N or less

Metric ISO/JIS Type

Order No.	Resolution	Measuring range	Throat depth	Anvil adjustment	Accuracy	Measuring force
547-313	0.01mm	0~10mm	30mm	12mm	±20μm or less	1.5N or less

Note) The accuracy specification does not include the quantizing error of ±1 count. Left-handed models can be supplied to special order.

ABS Digimatic Pipe Gauge



547-361S

- Designed for measuring the thickness of pipes and curved boards

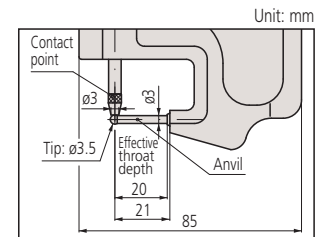

Unit: mm

Inch/Metric ANSI/AGD Type

Order No.	Resolution	Measuring range	Throat depth	Minimum inside diameter of pipe	Accuracy	Measuring force
547-361S	.0005"/0.01mm	0~.4"/0~10mm	20mm	ø3.5mm	±.001" or less	1.5N or less

Metric ISO/JIS Type

Order No.	Resolution	Measuring range	Throat depth	Minimum inside diameter of pipe	Accuracy	Measuring force
547-360	0.01mm	0~10mm	20mm	ø3.5mm	±20μm or less	1.5N or less

Note) 1. Changing the contact point requires total adjustment, including the main display unit. Contact Mitutoyo for advice.
 2. The accuracy specification does not include the quantizing error of ±1 count.
 3. Left-handed models can be supplied to special order.

Application Products

ABS Digimatic Groove Gage



547-3165

- Best suited for measuring the depth of narrow grooves on cylindrical workpieces
- The contact point and measuring face of the anvil are 1mm thick blades.

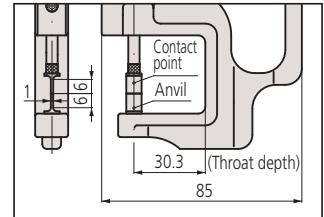

Unit: mm

Inch/Metric ANSI/AGD Type

Order No.	Resolution	Measuring range	Throat depth	Contact point and anvil dimensions (W x D)	Accuracy	Measuring force
547-3165	.0005"/0.01mm	0~4"/0~10mm	30mm	6.5mm x 1mm	±.001" or less	1.5N or less

Metric ISO/JIS Type

Order No.	Resolution	Measuring range	Throat depth	Contact point and anvil dimensions (W x D)	Accuracy	Measuring force
547-315	0.01mm	0~10mm	30mm	6.5mm x 1mm	±20µm or less	1.5N or less

- Note) 1. Changing the contact point requires total adjustment, including the main display unit. Contact Mitutoyo for advice.
 2. The accuracy specification does not include the quantizing error of ±1 count.
 3. Left-handed models can be supplied to special order.

ABS Digimatic Depth Gage

- Suitable for measuring the depth of holes, narrow grooves, and steps.
- The lifting lever can be used either on the left or right sides.



547-2185

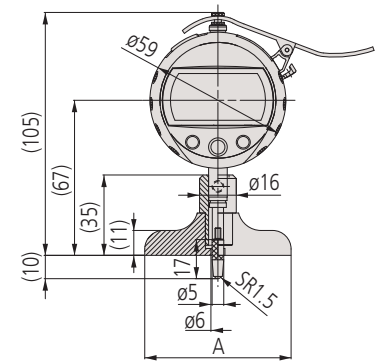

Unit: mm

Inch/Metric ANSI/AGD Type

Order No.	Resolution	Measuring range	Stroke	Accuracy	Measuring force	Base			Contact point: Carbide-tipped ball	Extension rods
						Length	Width	Flatness		
547-2175	.0005"/0.01mm	0~8"	.5"	±.001" or less	1.5N or less	2.5"	.63"	.0002" or less	21JAZA242	4 pcs. (.5", 1", 2", 4")
547-2185	.0005"/0.01mm	0~8"	.5"	±.001" or less	1.5N or less	4"	.63"	.0002" or less		4 pcs. (.5", 1", 2", 4")
547-2575	.00005"/0.001mm	0~8"	.5"	±.0002" or less	1.5N or less	2.5"	.63"	.00008" or less		4 pcs. (.5", 1", 2", 4")
547-2585	.00005"/0.001mm	0~8"	.5"	±.0002" or less	1.5N or less	4"	.63"	.00008" or less		4 pcs. (.5", 1", 2", 4")

Metric ISO/JIS Type

Order No.	Resolution	Measuring range	Stroke	Accuracy	Measuring force	Base			Contact point: Carbide-tipped ball	Extension rods
						Length	Width	Flatness		
547-211	0.01mm	0~200mm	12mm	±20µm	1.5N or less	63.5mm	16mm	5µm or less	21JAA224	5 pcs. (10, 20, 30, 100mm)
547-212						101.6mm		2µm or less		
547-251	0.001mm			±5µm	1.5N or less	63.5mm				
547-252						101.6mm				

Note) The accuracy specification does not include the quantizing error of ±1 count.

Unit: mm

ABS Digimatic Bench Gage

- The support plate allows easy reading by tilting the anvil.
- Carbide measuring faces (for the contact point and anvil)
- The lifting lever can be used either on the left or right sides.

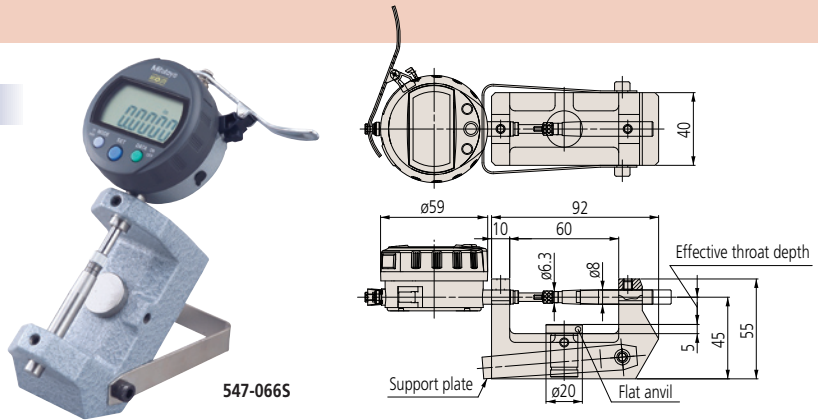

547-0665

Inch/Metric ANSI/AGD Type

Order No.	Indicator stroke	Resolution	Remarks (contact point)	Effective throat depth	Workpiece height	Accuracy	Measuring force
547-0665	.5"	.0005"/0.01mm	.248" DIA flat type	.59"	1"	±.001" or less	1.5N or less

Metric ISO/JIS Type

Order No.	Indicator stroke	Resolution	Workpiece height	Effective throat depth	Anvil adjustment	Accuracy	Measuring force
547-064	12mm	0.01mm	ø20mm	15mm	13mm	±20µm or less	1.5N or less

Note) The accuracy specification does not include the quantizing error of ±1 count.

ABS Digimatic Upright Gage

- Best suited for inspection of small parts at a site
- Carbide ball contact point
- The lifting lever that is a standard accessory for No. 547-054, 547-0345 can be used either on the left or right sides.

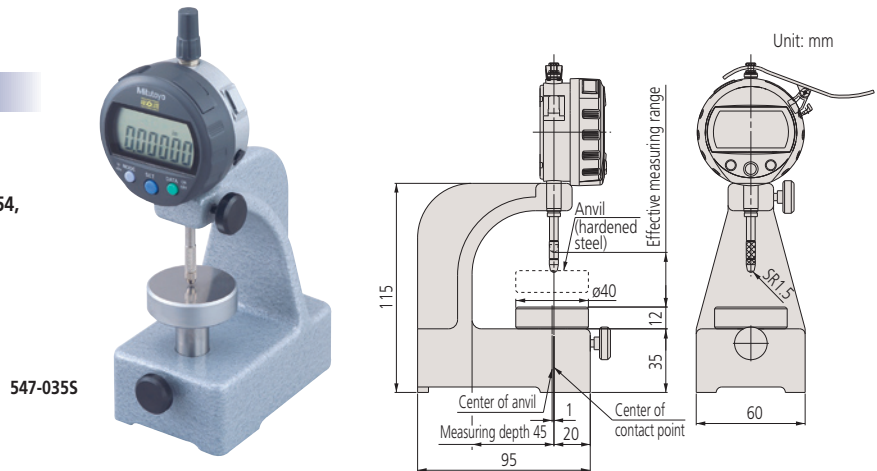

547-0355

Unit: mm

Inch/Metric ANSI/AGD Type

Order No.	Resolution	Measuring range	Anvil	Workpiece height	Accuracy	Measuring force
547-0345	.0005"/0.01mm	.5"	1.57" DIA steel type	1.2"	±.001" or less	1.5N or less
547-0335	.00005"/0.001mm	.5"	1.97" DIA ceramic type	1.2"	±.0001" or less	
547-0355	.00005"/0.001mm	.5"	1.57" DIA steel type	1.2"	±.0001" or less	

Metric ISO/JIS Type

Order No.	Resolution	Measuring range	Anvil	Workpiece height	Accuracy	Measuring force
547-054	0.01mm	12.7mm	ø40mm (steel type)	30mm	±20µm or less	1.5N or less
547-053	0.001mm	12.7mm	ø50mm (ceramic type)		± 3µm or less	
547-055	0.001mm	12.7mm	ø40mm (steel type)		± 3µm or less	

1. The lifting lever (part No. 21EZA198) is a standard accessory for 547-054.
2. The lifting lever (part No. 21EZA199) is a standard accessory for 547-0345.
3. The lifting cable (part No. 540774) is a standard accessory for 547-055, 547-0335, 547-0355.
4. The accuracy specification does not include the quantizing error of ±1 count.

- The ABS (ABSOLUTE) scale used in these products is a capacitance type absolute encoder. Its patent has been registered in Japan, the U.S., the U.K., Germany, and China.



Note: All information regarding our products, and in particular the illustrations, drawings, dimensional and performance data contained in this printed matter as well as other technical data are to be regarded as approximate average values. We therefore reserve the right to make changes to the corresponding designs. The stated standards, similar technical regulations, descriptions and illustrations of the products were valid at the time of printing. In addition, the latest applicable version of our General Trading Conditions will apply. Only quotations submitted by ourselves may be regarded as definitive.

Mitutoyo products are subject to US Export Administration Regulations (EAR). Re-export or relocation of Mitutoyo products may require prior approval by an appropriate governing authority.

Trademarks and Registrations

Designations used by companies to distinguish their products are often claimed as trademarks. In all instances where Mitutoyo America Corporation is aware of a claim, the product names appear in initial capital or all capital letters. The appropriate companies should be contacted for more complete trademark and registration information.

We reserve the right to change specifications and prices without notice.

- Coordinate Measuring Machines
- Vision Measuring Systems
- Form Measurement
- Optical Measuring
- Sensor Systems
- Testing Equipment and Seismometer
- Digital Scale and DRO Systems
- Small Tool Instruments and Data Management

Mitutoyo America Corporation

www.mitutoyo.com

One Number to Serve You Better
1-888-MITUTOYO (1-888-648-8869)

M³ Solution Centers

- Aurora, Illinois**
(Corporate Headquarters)
- Westford, Massachusetts**
- Huntersville, North Carolina**
- Mason, Ohio**
- Plymouth, Michigan**
- City of Industry, California**

Mitutoyo
 Precision is our Profession