



INSTALLATION INSTRUCTIONS

ACCEL Billet Aluminum Distributor with Electronic Advance and Adjustable Rev Limiter for 1952-70 Harley Sportster Motorcycles Model #A577

Note: Will also fit 1930-73 flathead (45 and UL)

OVERVIEW

ACCEL distributor Model A577 is intended for use with 1952-70 Harley-Davidson® Sportster motorcycle engines. The ACCEL A577 replaces the original equipment (OE) points type distributor. The unit can be installed without engine disassembly when stock cylinders and heads are used. The ACCEL A577 offers adjustable advance, adjustable RPM limit settings in 100 RPM increments, and switch selectable single or dual fire modes. Single fire mode improves starting, reduces the occurrence of backfiring at low RPM, and improves power at high RPM. A red status LED flashes when the engine reaches top dead center (TDC) and allows easy static timing. The status LED also provides diagnostic information. A green VOES LED illuminates when the VOES (vacuum switch) input is active.

AVOIDING HEAT RELATED FAILURES

Heat kills electronics. The ACCEL A577 uses electronic devices rated for operation at 105 deg. C (221 deg. F), the highest rating available. The unit can tolerate somewhat higher temperatures, but exposure to temperatures above 125 deg. C (257 deg. F) will greatly reduce life expectancy. We sometimes see problematic applications where several module failures have occurred. The failure mode is a classic thermal intermittent where the module stops firing one cylinder when it gets hot. We have found that these problematic applications share one or more of the following characteristics:

- VOES switch removed or non-functional. All street driven engines require vacuum advance. Without vacuum advance at idle and part throttle, thermo-

dynamic efficiency is reduced and engine temperatures increase significantly.

- Improper carburetor jetting resulting in lean air/fuel ratio (AFR). A lean AFR will cause the engine to run very hot. All performance engine modifications necessitate carburetor re-jetting. Carburetors are never correctly jetted out-of-the-box. The only practical means of correctly jetting a carburetor is to test the motorcycle on a chassis dyno equipped with an exhaust gas sniffer.
- Lack of an oil cooler on a high compression or larger engines.
- Exhaust pipe without heat shield in close proximity to the distributor.
- If any of the above applies to your application, the ACCEL A577 may be exposed to excessive temperatures resulting in reduced life expectancy. Use an infrared thermometer to check the module temperature.

INCLUDED AND ADDITIONAL REQUIRED PARTS

All units include a parts bag with crimp terminals for coil and VOES hookup.

- Electrical System - A 12 volt electrical system is required. Check that the charging system is properly regulated and not producing over 16 volts.
- Spark plugs – Resistor spark plugs must be used in place of the nonresistor spark plugs that were original equipment.
- Spark Plug wire - Spiral core or carbon core wire must be used in place of the solid core or copper core wire that was original equipment. We recommend the ACCEL 300+ Race Wire.
- Coil(s) – A coil or coils with a total primary resistance of 2-4 ohms is required. The stock 5 ohm coil is not compatible. For single fire we recommend the ACCEL 140408 coil. For dual fire use ACCEL part number 140407.

CAUTION: CAREFULLY READ INSTRUCTIONS BEFORE PROCEEDING. NOT LEGAL FOR USE OR SALE ON POLLUTION CONTROLLED VEHICLES

INSTALLATION

1. Turn off the ignition switch and disconnect the battery ground cable before proceeding.
2. Rotate the engine until it is on the compression stroke on the front cylinder. Continue to rotate the engine until the TDC mark is visible through the timing hole (Refer to Repair Manual if Necessary).
3. Remove the existing distributor if still in the engine.
4. Remove the two hex-head screws and the top cover from the new ACCEL A577 distributor. Remove the two hex standoffs and remove the module and upper housing from the distributor base assembly. (Figures 1 & 2)
5. Install the distributor base assembly in the engine with the screw holes and shutter wheel positioned as shown in Figure 3.
 2. It may be necessary to pull the distributor out, turn the shaft, and reinstall to get the shutter wheel at the approximate angle shown. The shutter wheel openings should be at about the 11 o'clock and 7 o'clock positions. The screw holes should be at the 9 o'clock and 3 o'clock positions.
6. Install the distributor clamp and snug the clamp bolt loosely so that the distributor can still be rotated.
7. Reinstall the upper housing and module assembly onto the distributor base assembly as shown in figure 1. Note: the upper housing will only install one way due to the locating screw. Rotate the base assembly slightly if necessary so that the opening in the shutter wheel lines up with the slot in the upper housing (Figure 4).
8. Reinstall the two hex standoffs through the module and upper housing and into the distributor base assembly. We recommend using a drop of

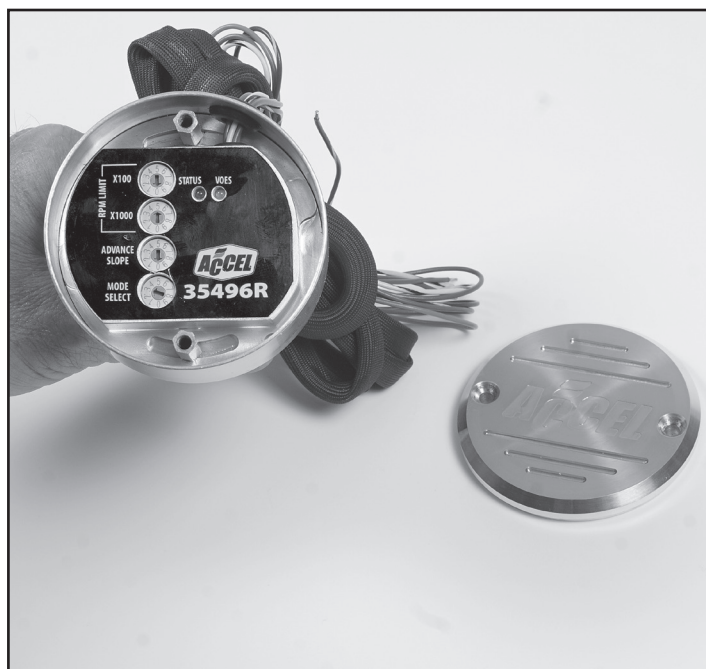

Figure 1

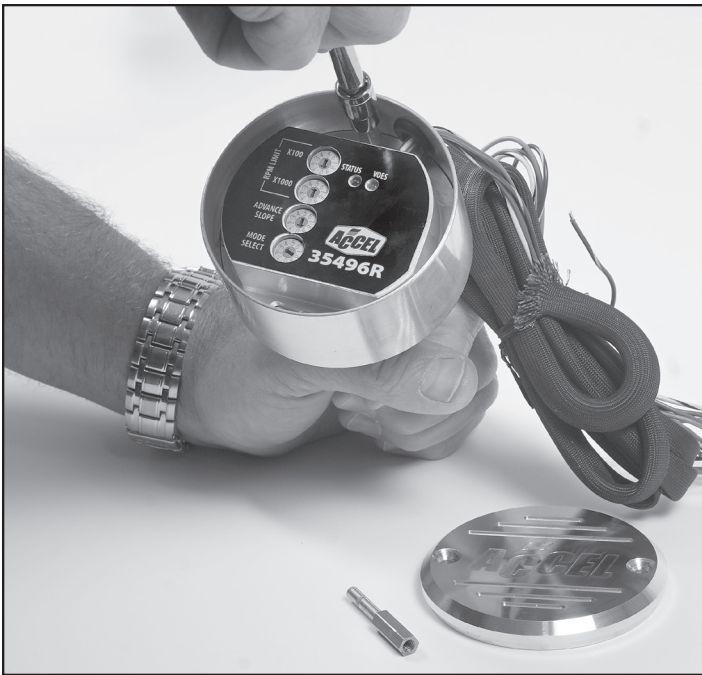

Figure 2



Figure 3



Figure 4

blue threadlock to prevent the standoffs from vibrating loose. Tighten the distributor clamp.

9. Set rotary switches according to the separate "Operating Figure 1 Modes" instruction below.

10. Install the top cover using the two supplied hex head screws. We recommend using a drop of blue threadlock to prevent the standoffs from vibrating loose.

11. Route the wiring harness between the pushrod tubes and the cylinders and up to the coil. Try to keep the harness away from the hot cylinder fins. Connect the wires as indicated in the attached "single fire/dual fire" wiring diagrams (page 4-5)

12. The timing should now be close enough to start the engine. If not, loosen the distributor clamp and turn the distributor slightly in either direction until the engine starts. Once the engine has warmed up, the timing can be set with a timing light. Adjustment to the timing can be made by loosening the distributor clamp and rotating the entire distributor. If necessary, the entire distributor can be removed and rotated one gear tooth to allow the wiring harness to run between the pushrod tubes and cylinders.

OPERATING FIGURE 1 MODES

A single 10 position rotary switch is used to select the operating mode. Switch settings are as follows:

- 0 Street advance curves, dual fire, multi-spark disabled
- 1 Street advance curves, dual fire, multi-spark enabled
- 2 Street advance curves, single fire, multi-spark disabled
- 3 Street advance curves, single fire, multi-spark enabled
- 4 Race advance curves, dual fire, multi-spark disabled
- 5 Race advance curves, dual fire, multi-spark enabled
- 6 Race advance curves, single fire, multi-spark disabled
- 7 Race advance curves, single fire, multi-spark enabled
- 8 Not used
- 9 Not used

The engine will not run if the mode switch setting does not match the wiring hookup (i.e. you cannot select single fire mode with a dual fire coil hookup). Advance curve families are shown in Figures 6 and 7. Use the street advance curves (mode switch settings 0-3) for stock or mildly modified engines. Use the race advance curves (mode switch settings 4-7) for high compression engines. We recommend that you enable multi-spark. When multi-spark is enabled, a continuous series of sparks is fired from the advanced timing point until TDC. Most air-cooled engines require relatively cold spark plugs to prevent detonation under high load. Multi-spark reduces the consequent tendency for plug fouling at idle.

CAUTION: Engine damage from excessive timing advance may result if the purple/white VOES wire is inadvertently shorted to ground.

RECOMMENDED TIMING SETTINGS

Street and race advance curve families are shown in Figures 6 and 7. Each family has minimum and maximum curves. The advance slope switch allows you to run an advance curve in between these minimum and maximum curves. Advance slope switch setting zero corresponds to the minimum advance curve. Switch setting 9 corresponds to the maximum advance curve. Higher switch settings result in a more aggressive curve.

Tuning a particular engine setup always requires some trial and error experimentation, but maximum power is usually obtained by using the highest advance setting possible without audible spark knock. Some recommended starting points are given below:

- For stock engines run on normal pump gas (87-89 octane), use the street advance curves and advance slope setting 5.
- For stock or mildly modified engines run on 92 or higher octane gas, use the street advance curves and advance slope setting 7.
- For high compression engines, use the race advance curves and advance slope setting 2.

You can adjust the initial timing by rotating the ACCEL module relative to the gear housing (clockwise rotation increases initial timing). If you experience spark knock only at low RPM, you can try reducing the initial timing while maintaining an aggressive advance slope for maximum power at high RPM by increasing the advance slope switch setting. If spark knock is a problem at high RPM, decrease the advance slope switch setting. Note that the wide-open throttle (WOT) curves are active unless the VOES input is

grounded. During idle and cruise, the VOES input is grounded (green VOES LED illuminated) and the low manifold pressure (MAP) curves are active.

RPM LIMITER SETTING

You can set the RPM limit from 3,000 to 9,900 RPM in 100 RPM increments by means of two rotary switches. The RPM limit is X100 switch setting (i.e. 57 = 5,700 RPM). Inadvertent settings below 3,000 RPM are ignored and result in a 3,000 RPM limit.

The Model 35496 uses a newly developed RPM limiting algorithm that has been highly optimized for odd firing V twin engines. When the engine is held against the RPM limit, cylinder firing is always paired. This eliminates a torque couple and results in very smooth operation compared to random or sequence type RPM limiters.

Set a safe RPM limit that is appropriate for your engine. Most Evolution® engines with OE valvetrain components should not be run over 5,700 RPM.

STATIC TIMING PROCEDURE

1. Timing marks are located on the flywheel and may be viewed by unscrewing the inspection hole plug. Most engines will have both TDC and advance timing marks for the front cylinder as shown on pg 7s. If you are not sure, refer to your shop manual. You can also identify the TDC mark by removing the spark plugs and rotating the crankshaft (turn rear wheel in high gear) until the front piston comes up on TDC.

2. For static timing, you must rotate the crankshaft so that the front piston is at TDC on the compression stroke. Remove spark plugs and rotate crankshaft. If you place your thumb over the spark plug hole, you will feel pressure as the piston comes up on the compression stroke. Continue rotating the crankshaft until the TDC mark is precisely centered in the inspection hole.

3. Ground the spark plug cables to avoid a shock hazard. You can use small jumper wires with alligator clips for this purpose.

4. Turn on the ignition switch. The red LED is used as a timing indicator. Note that the LED does not immediately illuminate when power is first turned on. Rotate the ignition unit back and forth until the red LED illuminates. Then slowly rotate the unit clockwise until the LED goes out. Note that the LED goes out at TDC.

5. Tighten the standoffs to secure the unit. Turn off the ignition switch and reinstall the spark plugs.

PRECISE TIMING PROCEDURE

1. Use a standard timing light. Note that most dial-back type timing lights will not work correctly with dual fire applications. If you have a dial-back timing light, set the dial-back to zero. Do not enable multi-spark while setting timing.

2. The precise timing procedure is based on using the 35° BTDC timing mark and race maximum advance curve with VOES grounded that reaches 35° BTDC around 2,000 RPM (refer to Figure 7). To use this procedure, you must have a VOES switch connected. If a VOES switch is not used, you must ground the purple/white wire while setting the timing.

3. Set mode switch to 4 for dual fire or 6 for single fire. Set advance slope switch to 9. Connect the timing light pickup to the front cylinder spark plug cable. Loosen standoffs securing the ignition unit. Run the engine at a steady speed just over 2,000 RPM. Rotate the ignition to center the 35° BTDC timing mark in the inspection hole. Tighten standoffs and verify that the timing has not changed. When done, change mode and advance slope switches back to desired values.

GENERAL RECOMMENDATIONS

Coil primary resistance must not be less than 3 ohms. Most OE style dual fire and aftermarket single fire coils meet this requirement. Coils for the new Twin Cam engine have low primary resistance and are not compatible. Due to the short lengths involved on motorcycle applications, energy losses in spark plug wires are insignificant. OE carbon core suppression cables will deteriorate after several years. For a more durable replacement, we suggest spiral core spark plug cables.

The ACCEL module is compatible with all modern "ground sensing" type tachometers including H-D® OE and Autometer units. The red status LED is internally connected to the tachometer output. If the red status LED blinks, the tachometer output should be functional. Some early tachometers require a high voltage trigger pulse. In this case, you will require a commercially available tachometer adapter.

VOES CONSIDERATIONS

The vacuum switch (VOES) provides the vacuum advance required by all street driven engines. Additional advance under low manifold pressure conditions improves idle stability and fuel economy. Most 1980 and later motorcycles are equipped with a OE VOES. Without vacuum advance at idle and part throttle, thermodynamic efficiency is reduced and engine temperatures increase significantly.

The VOES is normally open. At low manifold pressure (or manifold vacuum greater than about 5 inch-Hg), the VOES grounds the purple/white wire and causes the ACCEL module to generate additional timing advance. The green VOES LED illuminates whenever the VOES input is active (timing advanced). The use of a VOES is required for proper operation of the ACCEL module. If your motorcycle did not include an OE VOES, you can use H-D® VOES P/N 26566-91 for stock or mildly modified engines.

TROUBLESHOOTING FLOWCHART

Follow the troubleshooting flowchart shown on pg. 7. Experience has shown that most units returned for warranty are OK and another problem, such as a defective coil, is later identified.

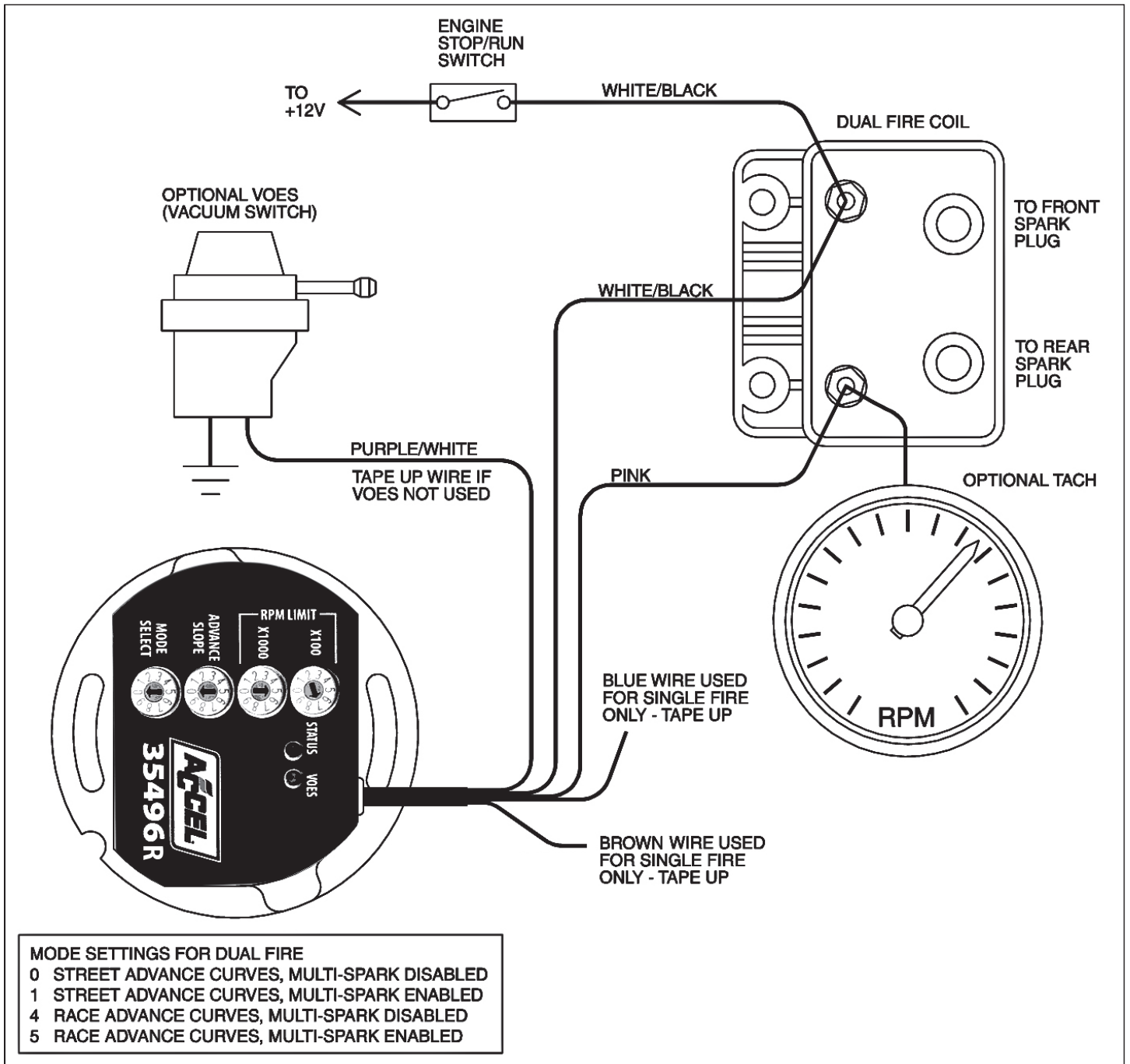

Figure 4 - Dual Fire Wiring Diagram

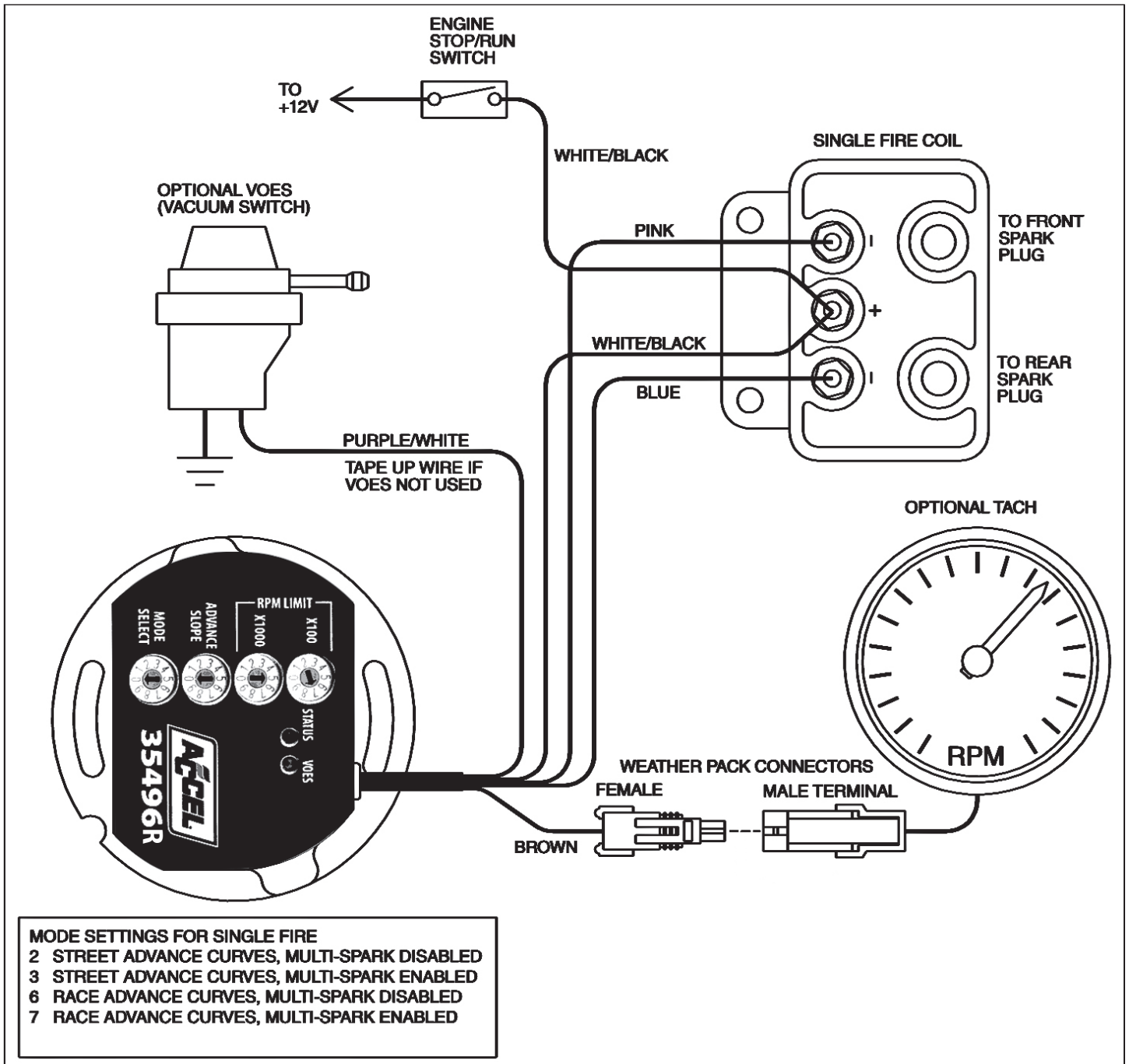

Figure 5 - Single Fire Wiring Diagram

TUNING TIP: Lean air/fuel ratio (AFR) increases the tendency for spark knock. Check AFR and rejet carburetor before optimizing ignition timing. Test the motorcycle on a dyno with an exhaust gas sniffer.

Figure 6 - Street Advance Curves

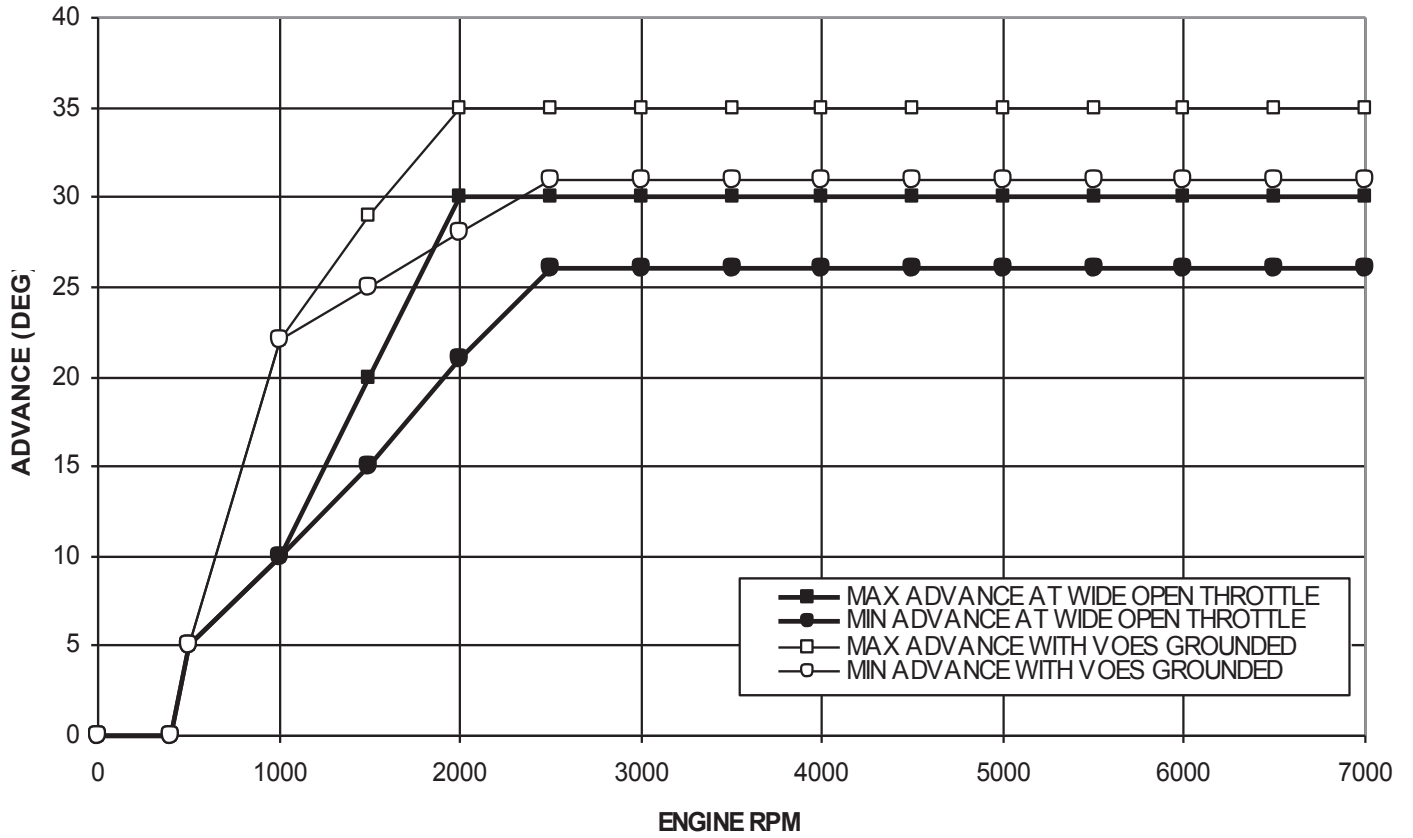
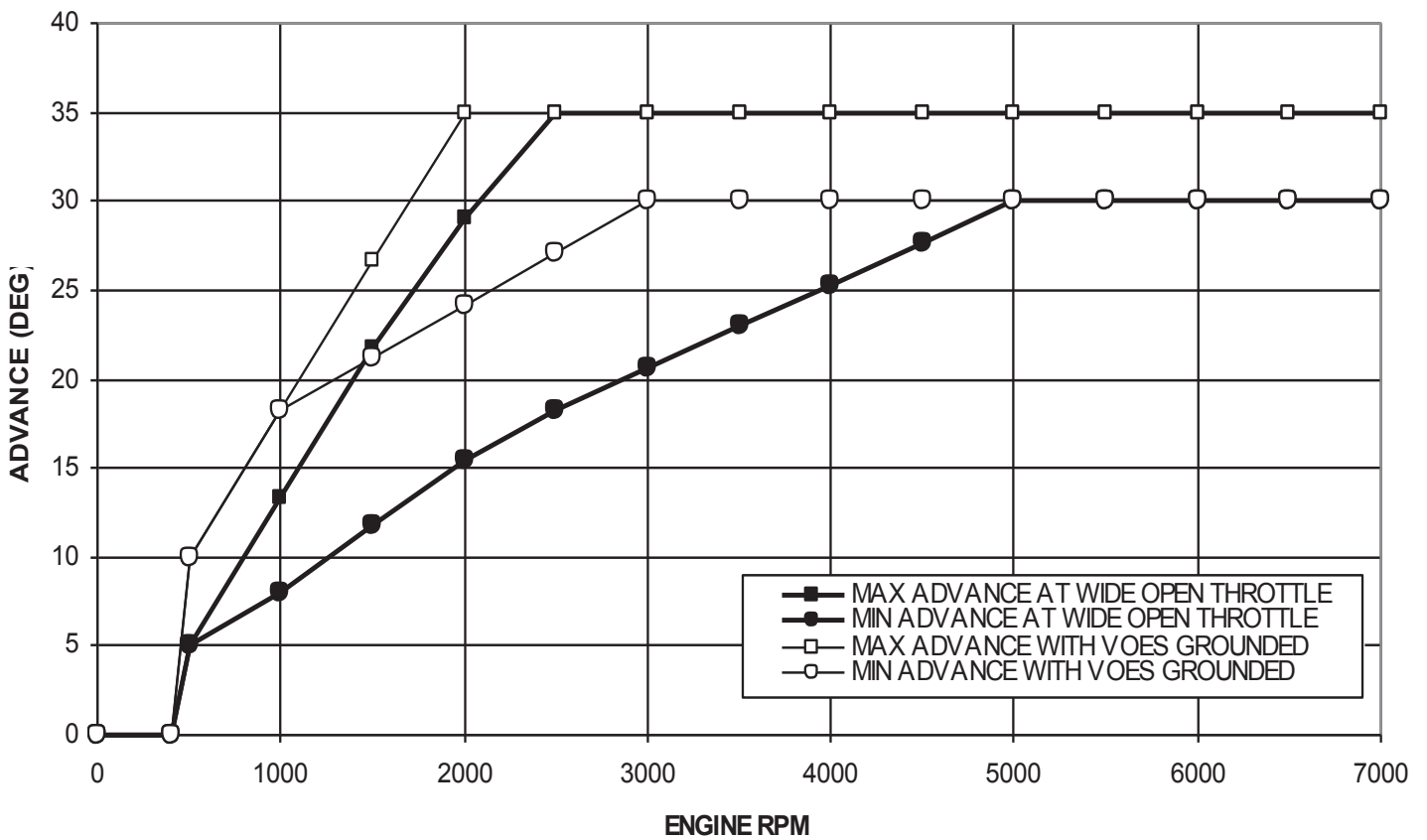
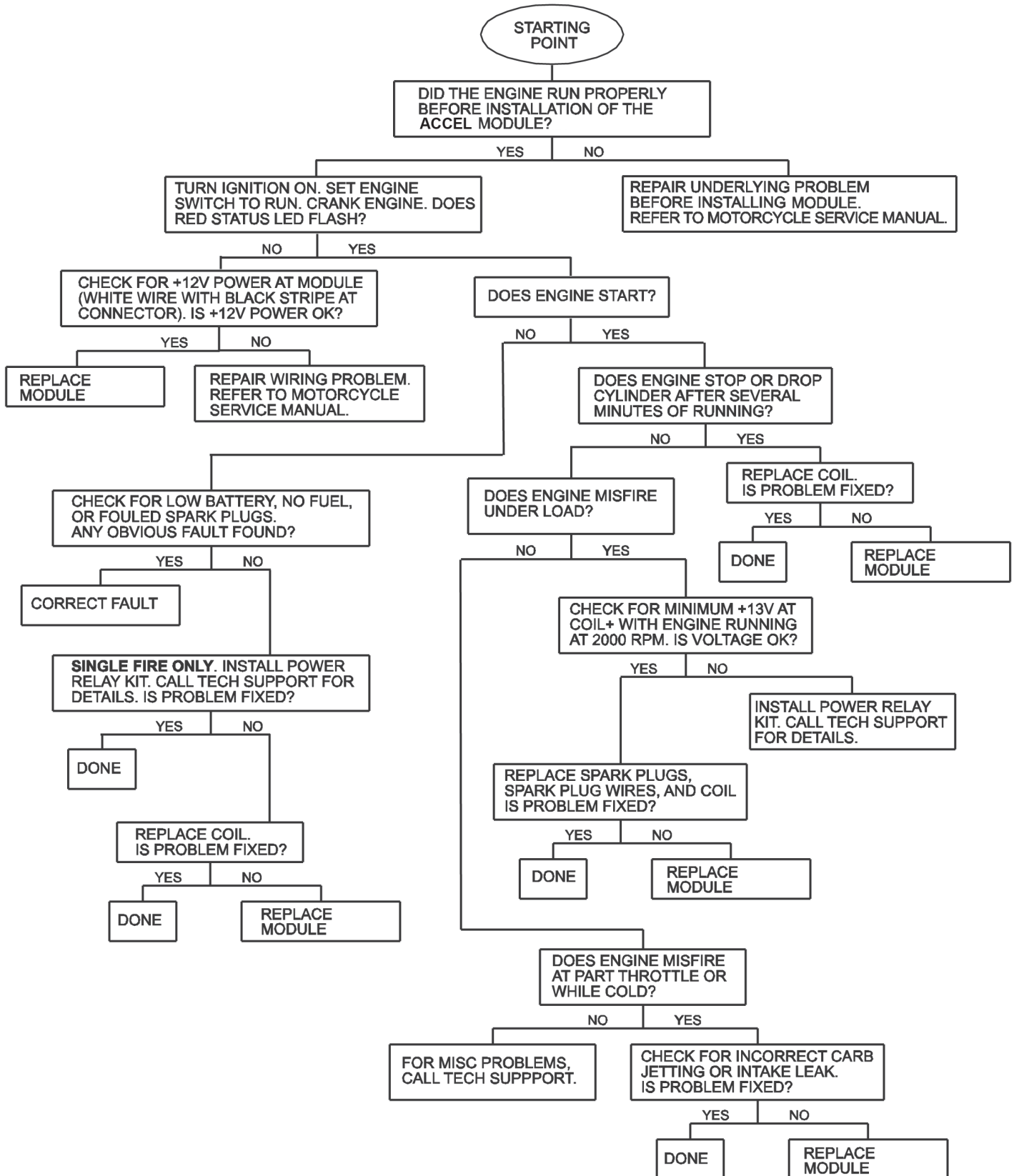

Figure 7 - Race Advance Curves



TROUBLESHOOTING FLOWCHART



**Check out
www.accel-motorcycle.com for the what's new in-
Stealth SuperCoils
Stealth SuperTuners
Spark Plugs
Spark Plug Wire Sets
Charging System Components
Ignition Coils
Tune Up Parts
And Much More**



ACCEL IS A TRADEMARK OF ACCEL PERFORMANCE GROUP
1801 RUSSELLVILLE ROAD, BOWLING GREEN, KY
42101 270-781-9741 OR 866-464-6553

FORM 1626 REV1