



# Acoustical Shells

Incredible acoustics and sophisticated looks in the auditorium and throughout the facility.



## DIVA® FULL-STAGE ACOUSTICAL SHELLS

Great concern should be given to the investment qualities of an acoustical shell. An investment in a Diva full stage acoustical shell will reward you the first time you hear the remarkable difference. It provides unparalleled quality, and its durability provides long-term added value. Plus a Diva full-stage acoustical shell is a beautiful centerpiece that projects an ongoing image of excellence.

Ease of operation alone makes a Diva full-stage acoustical shell worth the investment. The time and effort saved in setup is significant and the shell system is incredibly easy to use. The modular design works well for all kinds of events. No other acoustical shell has so much added value, which makes the return on investment considerable and ongoing.

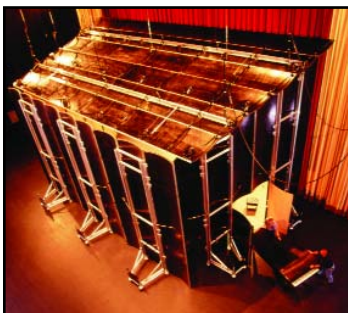

**ALUMINUM FRAME WITH MAINTENANCE-FREE HINGES.** Diva's extruded aluminum structural frame is extremely rigid and keeps Diva panels aligned for the finest visual appearance. The lightweight aluminum design also promotes easy operation and provides key economies.



## LEGACY® ACOUSTICAL SHELL

Legacy acoustical shells use the latest Wenger technology to give you an attractive, effective acoustical enclosure at an affordable price. They can be set up quickly and easily by just one person. And their mobility allows you to acoustically transform any space into a performance venue.

Wenger pioneered acoustical shell design, so it's no surprise that Legacy acoustical shells improve acoustics for better sound ensemble onstage while delivering a fuller, richer sound to the audience. And when the curtain falls, Legacy acoustical shells strike in no time and nest compactly.

Legacy acoustical shell units feature composite-panel construction that enhances both the sound heard on stage as well as the sound projected to the audience.

### FREEDOM & FLEXIBILITY OF ONE-PERSON SETUP



Roll Legacy acoustical shell into place. Lower kick panel and raise and set canopy.

Use tool to adjust canopy angle for optimum sound delivery.

Turn handle of lift mechanism to set shell height into performance position.

# ACOUSTICAL SHELL ENCLOSURES

## Application Information

### Diva® Shell Wall Towers (Rolling/Movable)

- Shell Towers are designed to move from storage to performance positions — and nest one within the other for compact storage.
- Shell Towers are constructed of materials to effectively reflect sound.
- Consideration should be given to method of movement, and to permanent stage floor construction as it relates to the weight of the shell towers.
- Diva and Custom Design/Build Shell models incorporate access doors for personnel and equipment access to the performance area.
- Diva towers are moved with an exclusive Air Transporter which makes consistent shell placement an easy process and which also greatly reduces wear and damage to the floor.

### Diva Shell Ceiling Panels

- Ceiling panels are designed to be suspended from standard stage rigging hardware (rigging to be provided by others).
- Each row of shell ceilings is designed to be suspended from one pipe batten or line set. It is recommended that this line set be dedicated to the shell ceiling suspension.
- Pipe battens — which are installed by a rigging contractor, should be centered over each row of ceiling panels.
- Storage — ceilings are designed to rotate to a vertical position for storage in the stage loft area. Ceiling panels can be specified to be removable to free up additional line sets.
- Give proper consideration to shell ceiling weight and rigging line set capacity.
- Lighting — shells can be lit with the following:
  - a. Integrated light fixtures within the shell ceiling.
  - b. Existing or standard stage lighting — ceilings can be designed to fit between existing lighting.

Give special consideration to shell ceiling weight and rigging line set capacity and locations. Pipe battens, which are installed by a rigging contractor, should be centered over each row of ceiling panels. Contact Wenger for assistance.

### Diva Acoustical Shell Features

- The design, flexibility and extensive finish options of the Diva Acoustical Shell provide a customized shell at an affordable price.
- A combination of shell towers and ceiling rows form a full-stage acoustic enclosure.
- The modular design allows for flexible configurations that can fit ensembles and performances of all sizes.
- Rigid composite panels improve acoustics. Curved panel surfaces reflect and diffuse sound for optimum acoustical performance.
- Two standard tower widths:
  - 10' (3.05 m) 4' (1.22 m) center and 3' (0.91 m) wings
  - 12' (3.66 m) 4' (1.22 m) center and 4' (1.22 m) wings.
- Towers can be sized to your specification, with heights from 16' to 30' (4.87 m to 9.14 m).
- A variety of painted and wood finishes help to make the Diva Acoustical Shell aesthetically pleasing and visually define a performance area.
- Standard Class A fire rating finishes are provided.
- The Diva Acoustical Shell is designed to significantly reduce setup time.
- The patented Air Transporter lifts and moves towers on a cushion of air to reduce stage floor damage.
- The Diva Acoustical Shell tower frames and ceiling trusses are manufactured with rigid aluminum.
- Shell towers are counterweighted for stability. Diagonal bracing, between tower base and frame, provides structural integrity.
- Wenger works to integrate Diva ceiling rows with existing or new theatrical rigging. Rows of ceilings rotate to the vertical position for storage and lock into the performance position for fast setup.
- Ceiling aluminum trusses provide space for an integrated electrical raceway that supplies power for optional lighting packages.
- Access Doors are available including double doors that accommodate a grand piano.
- Towers nest together for compact storage with minimal footprint — in alcove, stage wing or backstage.

# ACOUSTICAL SHELL ENCLOSURES

## Application Information

Front Elevation of Typical DIVA Acoustical Shell

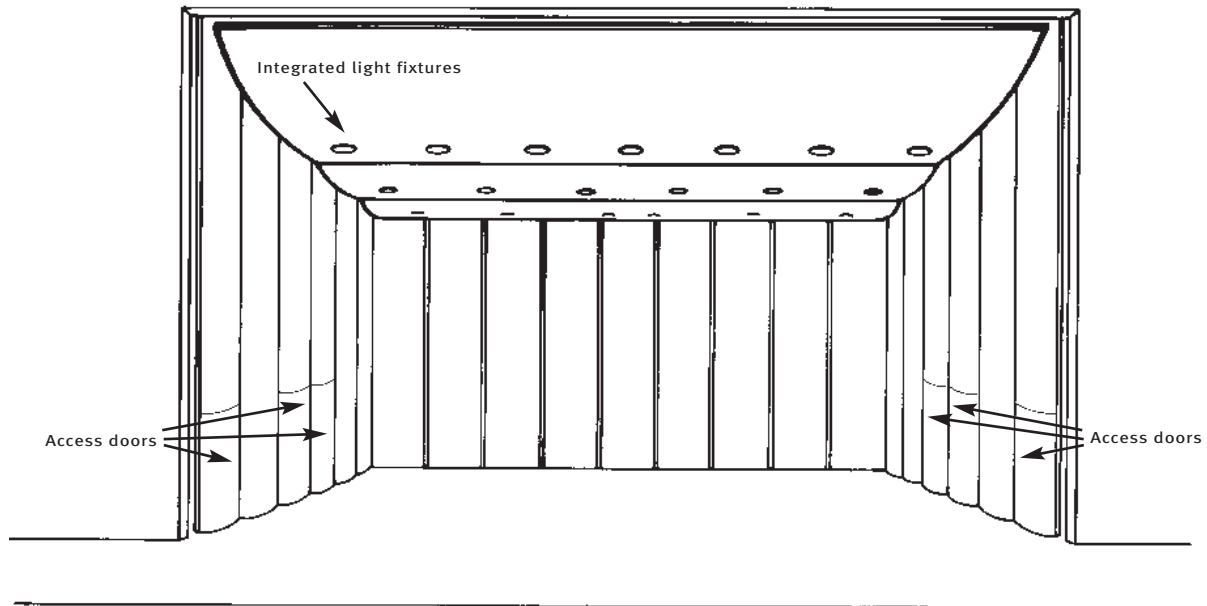

# ACOUSTICAL SHELL ENCLOSURES

## Application Information

### Symbols for Standard Ceiling Panels and Towers

Stage rigging not supplied by Wenger.

All symbols are available on the Wenger Music Facility Products CD included with this Data Book

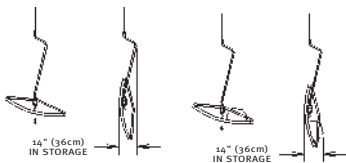

4' (122 cm) ceiling

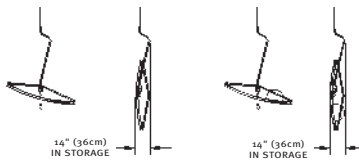

5' (152 cm) ceiling

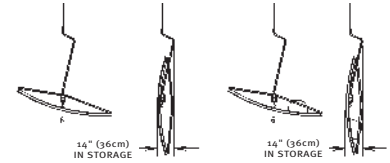

6' (183 cm) ceiling

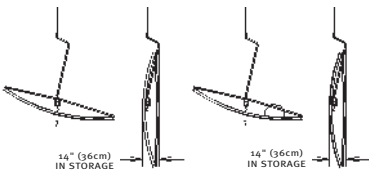

7' (213 cm) ceiling

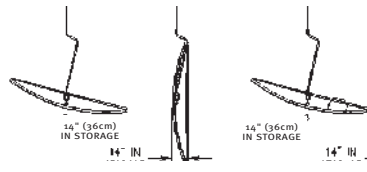

8' (244 cm) ceiling

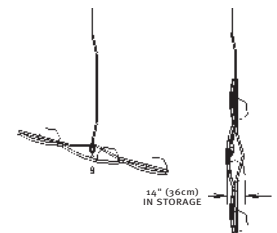

9' (2.74 m) ceiling

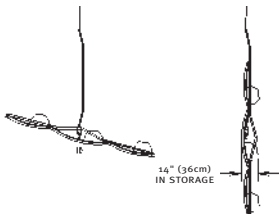

10' (3.04 m) ceiling

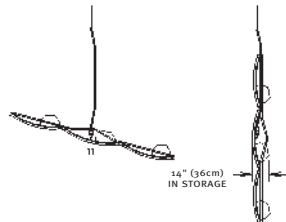

11' (3.35 m) ceiling

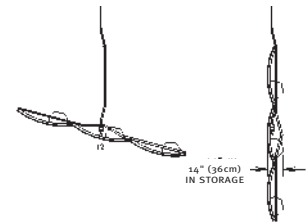

12' (3.65 m) ceiling

### Notes:

1. Ceiling assemblies will weigh about 4 pounds (1.81 kg) per square foot.
2. Each light assembly will weigh about 25 pounds (11.34 kg).
3. Panels that are painted will be constructed of  $\frac{3}{16}$ " (0.47 cm) hardboard on both sides of  $\frac{1}{2}$ " (3.81 cm) paper honeycomb.
4. Panels that are veneered will be constructed of  $\frac{1}{4}$ " (0.63 cm) veneered MDF plywood on face side of  $\frac{1}{2}$ " (3.81 cm) paper honeycomb. Back is  $\frac{3}{16}$ " (0.47cm) hardboard painted black.

# ACOUSTICAL SHELL ENCLOSURES

## Application Information

### Diva Shell Towers

TOP VIEW 12' (3.65m) TOWER

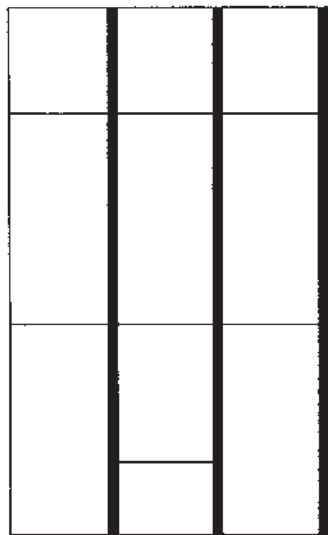
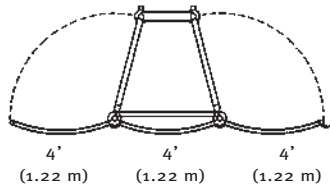

FRONT ELEVATION

TOP VIEW 10' (3.04m) TOWER

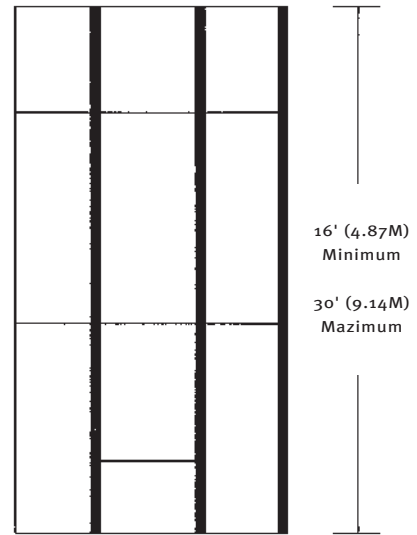
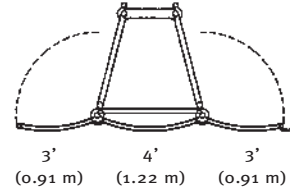

FRONT ELEVATION

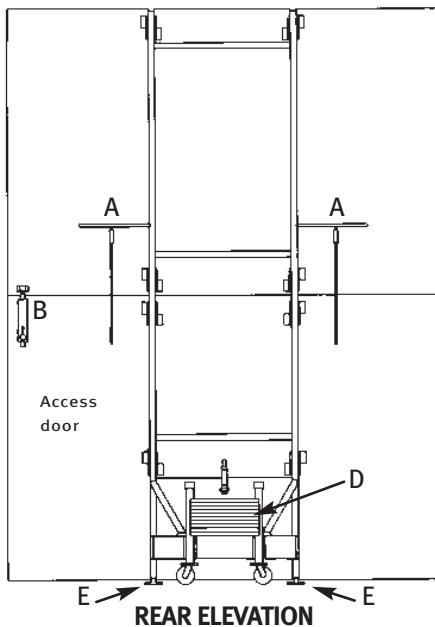

REAR ELEVATION

The Diva Tower shown from the back.

Telescoping wing-stays lock wings into performance and storage positions (A).

The counterweighted base (D) provides shell stability when shell is stationary or being moved with Air Transporter.

The shell rests on leveling pads (E) for uniform set-up on uneven floors.

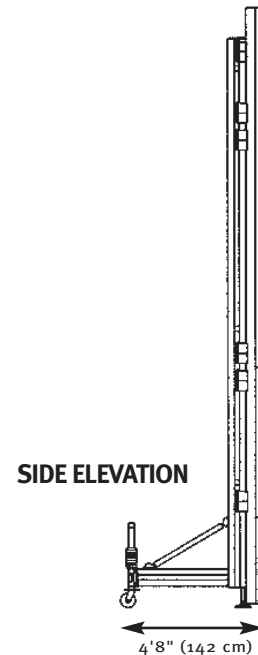

# ACOUSTICAL SHELL ENCLOSURES

## Application Information

### Diva Air Transporter

Wenger's Patented Air Transporter literally moves Diva towers on a cushion of air. Diva glides over virtually any hard surface, even stage floor irregularities. The Air Transporter saves time and problems for stage crews while protecting the stage floor from damage.

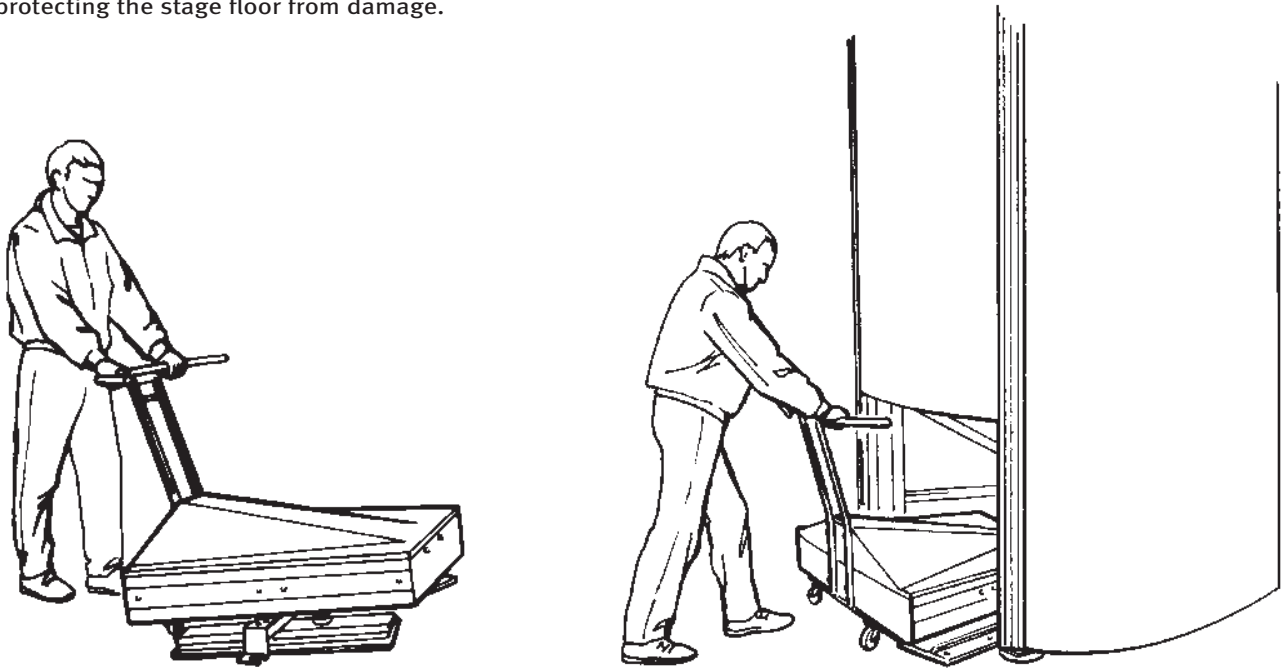

### Diva Towers in Storage

Top view showing how Diva towers nest together in storage position, minimizing required storage space.

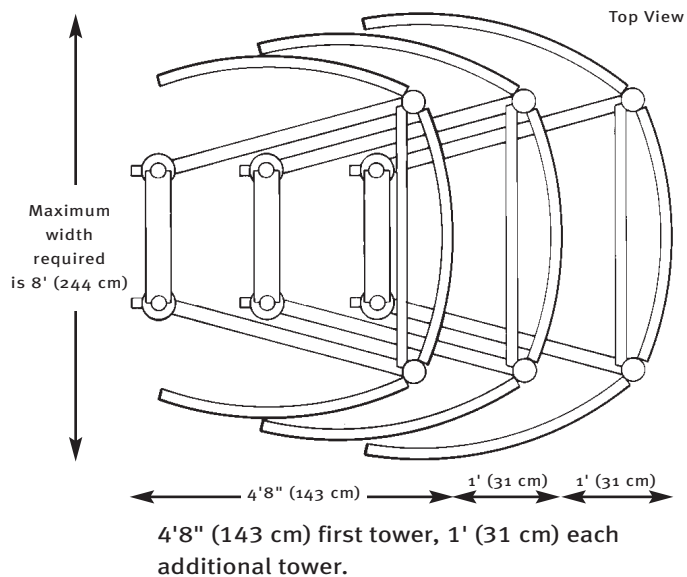

# ACOUSTICAL SHELL ENCLOSURES

## Application Information

### Diva Shell Ceiling Panels

Stage rigging not supplied by Wenger.

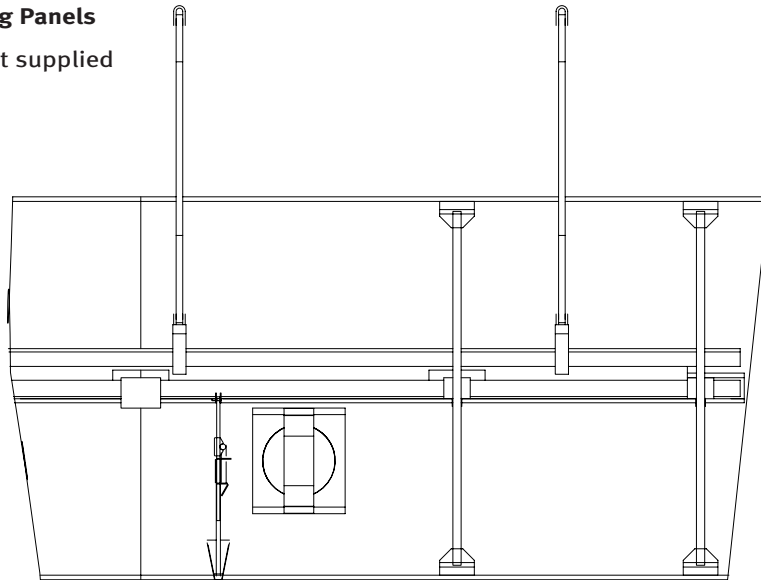

Back View of Ceiling Panel in Storage Position

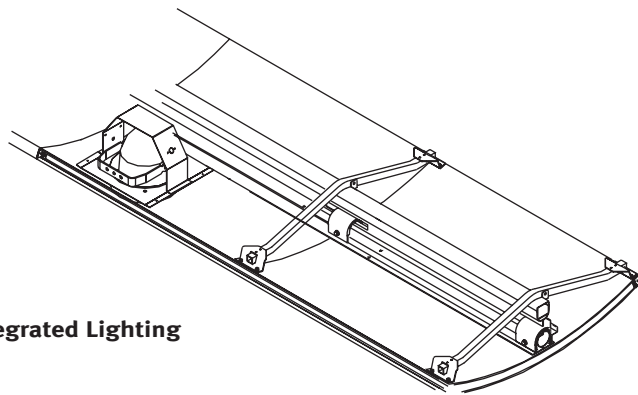
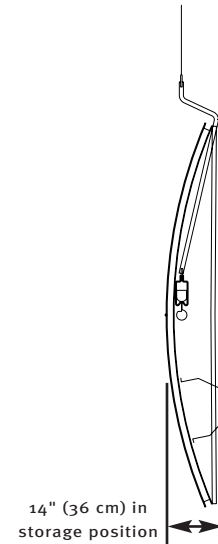

### Integrated Lighting

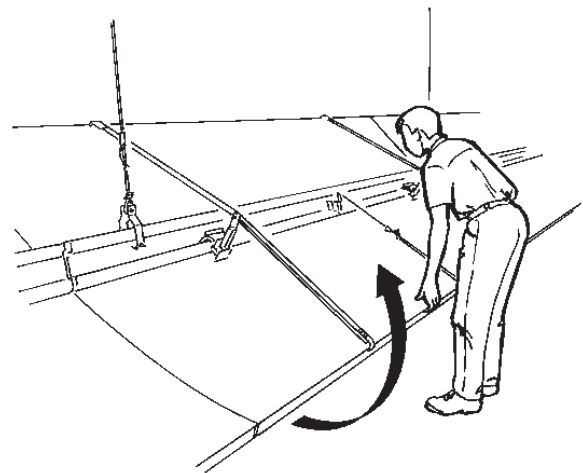

### Ceiling Performance Angle

The angle of the ceilings can be adjusted for different acoustical requirements.

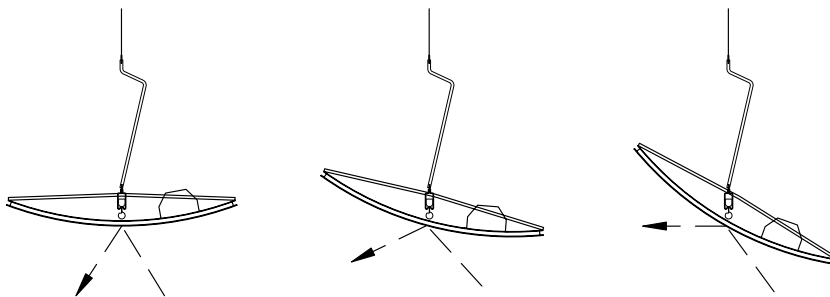

Ceilings placed in a more horizontal position will return more sound energy to the performers on stage. Ceilings placed at a steeper angle will reflect more sound energy to the audience.

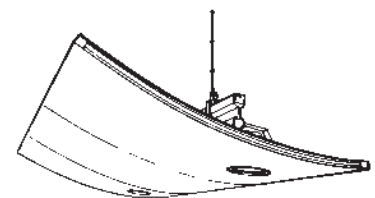

Shell ceiling in performance position.



# ACOUSTICAL SHELL ENCLOSURES

## Application Information

### Typical Layout for a 70' x 35' (21.3 x 10.6 m) Performance Area

Contact Wenger for a layout designed to fit your facility.

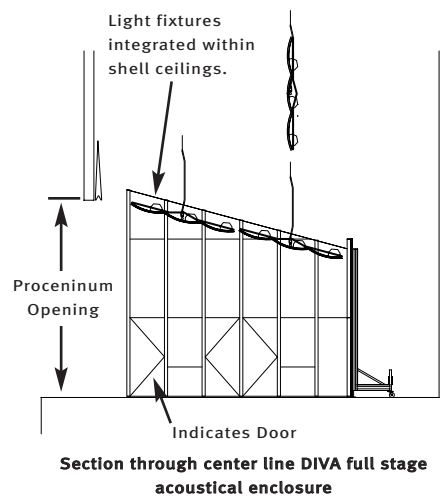
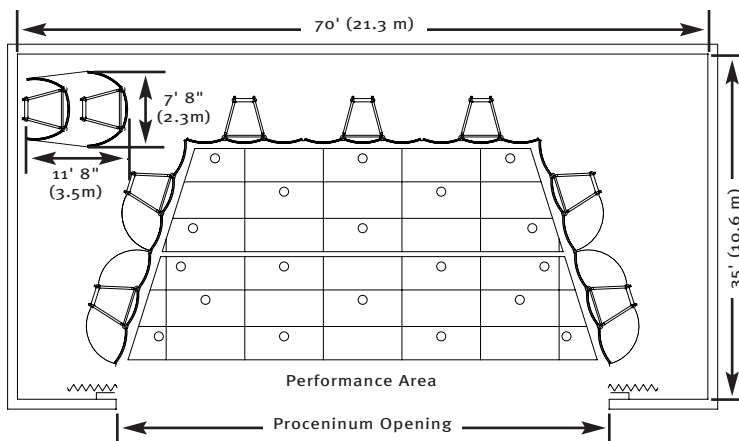
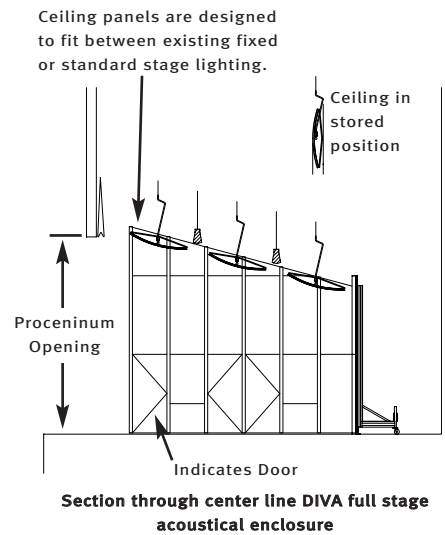
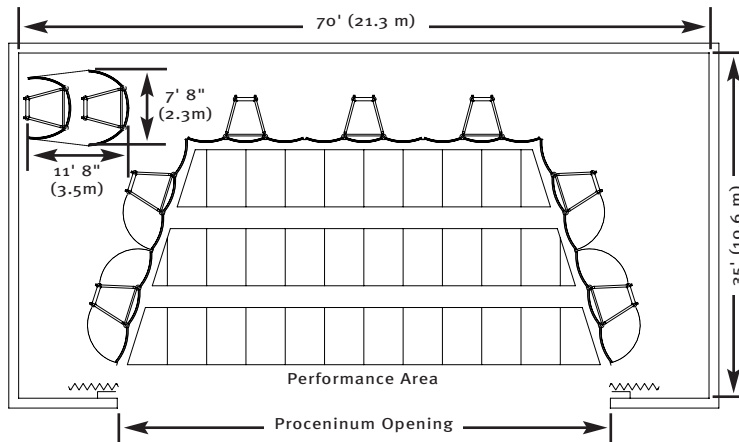

# ACOUSTICAL SHELL ENCLOSURES

## Application Information

### Legacy® Acoustical Shell

- Most economical of our standard shells.
- Towers retract to permit easy movement through a 35" x 79" (89 x 201 cm) opening for a standard 36" (91 cm) door. (Not recommended for applications where shells will have to be moved up and down stairways.)
- The counterweight assembly is located on the backside of the unit to eliminate trip hazards for the performers, allowing for a clean front surface.
- Towers are on caster bases:
  - Permits safe and easy movement between storage and the performance area.
  - Allows shell configurations of different sizes.
  - Tower bases nest within each other and thus take a minimum amount of floor area for storage.
- Square or tapered tower canopy available. Choose to fit your application.
- Base and frame are constructed of durable steel and aluminum.
- Panels are a composite type consisting of a honeycomb core providing a stiff acoustically reflective surface.
- Panel edges consist of a sleek and attractive aluminum extrusion with rounded corners for added safety.
- Maximum height of tower can be 15'2" (462 cm).
- Canopy can be put into 1 or 4 positions for performance (45, 60, 75 or 90 degrees).
- Available in a neutral oyster color.
- Towers are designed for safe one person operation.
- Only 6 turns of the handle are required to raise the shell to its performance position.
- Five year warranty.

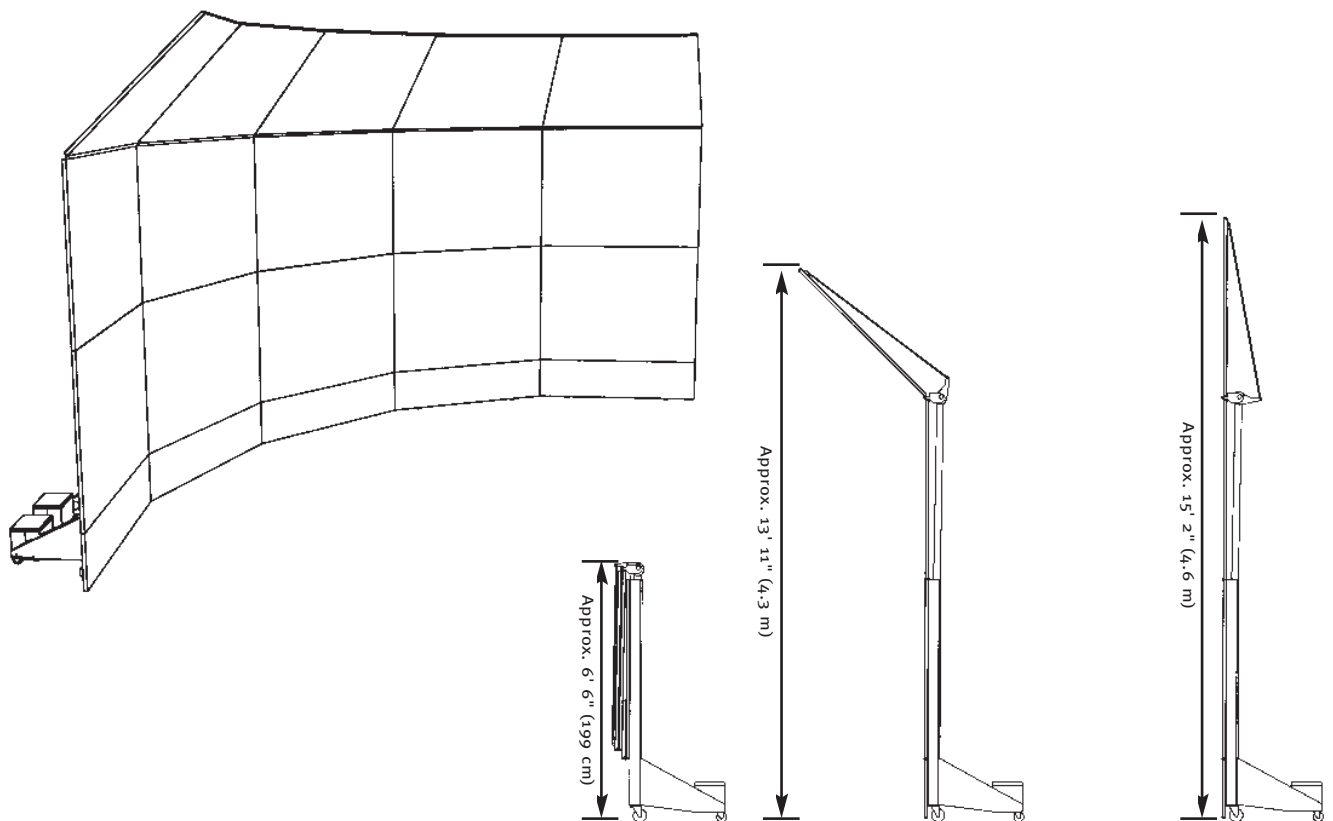

Please call your Wenger representative for technical drawings and information on Legacy Full Stage and Custom shells.