

AD-A102 363

SYNECTICS CORP ROME N Y
IAF GEOGRAPHIC DATA PROCESSING SYSTEM.(U)
JUN 81 J DECKER, M NEWMAN

F/G 9/2

UNCLASSIFIED

RADC-TR-81-121

F30602-78-C-0278

NL

1 0+ 1
AD 4
102,463

END

DATE

FILMED

8-81

DTIC

AD A102363

JL

RADC-TR-81-121
Final Technical Report
June 1981

LEVEL II

12



IAF GEOGRAPHIC DATA PROCESSING SYSTEM

Synectics Corporation

J. Decker
M. Newman

DTIC
ELECTE
S AUG 03 1981

F

APPROVED FOR PUBLIC RELEASE; DISTRIBUTION UNLIMITED

DTIC FILE COPY

ROME AIR DEVELOPMENT CENTER
Air Force Systems Command
Griffiss Air Force Base, New York 13441

81 8 03 064

This report has been reviewed by the RADC Public Affairs Office (PA) and is releasable to the National Technical Information Service (NTIS). At NTIS it will be releasable to the general public, including foreign nations.

RADC-TR-81-121 has been reviewed and is approved for publication.

APPROVED:



JOHN R. BAUMANN
Project Engineer

APPROVED:

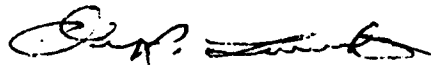

OWEN R. LAWTER, Colonel, USAF
Chief, Intelligence and Reconnaissance Division

FOR THE COMMANDER:



JOHN P. HUSS
Acting Chief, Plans Office

If your address has changed or if you wish to be removed from the RADC mailing list, or if the addressee is no longer employed by your organization, please notify RADC (IRRP) Griffiss AFB NY 13441. This will assist us in maintaining a current mailing list.

Do not return this copy. Retain or destroy.

UNCLASSIFIED

SECURITY CLASSIFICATION OF THIS PAGE (When Data Entered)

REPORT DOCUMENTATION PAGE		READ INSTRUCTIONS BEFORE COMPLETING FORM
1. REPORT NUMBER RADC-TR-81-121	2. GOVT ACCESSION NO. AD-A 102 363	3. RECIPIENT'S CATALOG NUMBER
4. TITLE (and Subtitle) IAF GEOGRAPHIC DATA PROCESSING SYSTEM	5. TYPE OF REPORT & PERIOD COVERED Final Technical Report, Aug 78—Jan 81	6. PERFORMING ORG. REPORT NUMBER N/A
7. AUTHOR(s) J. Decker M. Newman	8. CONTRACT OR GRANT NUMBER(s) F30602-78-C-0278	
9. PERFORMING ORGANIZATION NAME AND ADDRESS Synectics Corporation 310 East Chestnut Street Rome NY 13440	10. PROGRAM ELEMENT, PROJECT, TASK AREA & WORK UNIT NUMBERS 62702F 45941701	
11. CONTROLLING OFFICE NAME AND ADDRESS Rome Air Development Center (IRRP) Griffiss AFB NY 13441	12. REPORT DATE June 1981	13. NUMBER OF PAGES 26
14. MONITORING AGENCY NAME & ADDRESS (if different from Controlling Office) Same	15. SECURITY CLASS. (of this report) UNCLASSIFIED	15a. DECLASSIFICATION/DOWNGRADING SCHEDULE N/A
16. DISTRIBUTION STATEMENT (of this Report) Approved for public release; distribution unlimited.		
17. DISTRIBUTION STATEMENT (of the abstract entered in Block 20, if different from Report) Same		
18. SUPPLEMENTARY NOTES RADC Project Engineer: John R. Baumann (RADC/IRRP)		
19. KEY WORDS (Continue on reverse side if necessary and identify by block number) Advanced Cartographic System System Design to Implementation Multiprocessor Systems Support Interactive Product Array Processing Generation Environment Digital Landmass System Products		
20. ABSTRACT (Continue on reverse side if necessary and identify by block number) The objective of this report was to design and develop a comprehensive digital landmass system (DLMS) digitizing/processing system and a DLMS processing support subsystem to acquire and organize terrain and planimetric data into a common digital landmass data bank. The project maintained a twofold purpose. The first was to identify the best hardware and software components and integrate them into an		

DD FORM 1473

1 JAN 73

EDITION OF 1 NOV 65 IS OBSOLETE

UNCLASSIFIED

(Cont'd)

SECURITY CLASSIFICATION OF THIS PAGE (When Data Entered)

UNCLASSIFIED

SECURITY CLASSIFICATION OF THIS PAGE(When Data Entered)

Item 20 (Cont'd)

efficient cartographic digitizing and editing subsystem aimed at supporting the creation of digital cartographic feature files. These files were sufficiently described to permit subsequent processing of the data to digital landmass simulation products. The other purpose was to provide a subsystem with state-of-the-art technology and proven concepts to support the processing of digital cartographic files for generating digital landmass system products.

The two functional areas of the GDPS (Data Acquisition and Validation and Post-Processing in Support of Product Generation) have specific data processing requirements. These requirements (graphic data handling in a highly interactive procedure environment and large amounts of mass storage and computation time) demand a responsive hardware configuration plus a user-oriented software architecture.

Accession For	
NTIS GRA&I	<input checked="" type="checkbox"/>
DTIC TAB	<input type="checkbox"/>
Unannounced	<input type="checkbox"/>
Justification	
By _____	
Distribution/ _____	
Availability Codes	
Dist	Avail and/or Special
A	

UNCLASSIFIED

SECURITY CLASSIFICATION OF THIS PAGE(When Data Entered)

TABLE OF CONTENTS

1.	INTRODUCTION	1- 1
	1.1 General	1- 1
	1.2 Background	1- 1
	1.3 Scope	1- 1
	1.4 Objectives	1- 2
2.	SYSTEM OVERVIEW	2- 1
	2.1 Subsystem Concept	2- 1
	2.2 GDPS-DS Role	2- 1
	2.3 DLMS-PS Role	2- 1
	2.4 Data Flow Description	2- 2
3.	HARDWARE OVERVIEW	3- 1
	3.1 GDPS Subsystem Configuration Concept	3- 1
	3.2 GDPS-DS	3- 1
	3.3 DLMS-PS	3- 4
4.	FUNCTIONAL OVERVIEW	4- 1
	4.1 GDPS-DS Functions	4- 1
	4.1.1 Digitizing Functions	4- 1
	4.1.2 FADT Processing Functions	4- 3
	4.1.3 Digitized Data Plots	4- 3
	4.2 DLMS-PS Functions	4- 4
	4.2.1 Terrain Functions	4- 4
	4.2.2 Culture Processing	4- 5
5.	TESTING/EVALUATION	5- 1
	5.1 Test Data	5- 1
	5.2 Test Procedures	5- 1
	5.3 Test Results	5- 2
6.	CONCLUSIONS AND RECOMMENDATIONS	6- 1
	6.1 Conclusions	6- 1
	6.2 Recommendations	6- 1
	6.2.1 Americanization of the GDPS	6- 1
	6.2.2 Analysis of GDPS Products	6- 2
	6.2.3 Analysis of DLMS Products	6- 2

TABLE OF CONTENTS (CONTINUED)

6.2.4	Test Data Base Generation	6- 2
6.2.5	GDPS Utilization at the Production Centers . . .	6- 2
6.2.6	C ³ I Requirements	6- 3

LIST OF FIGURES

2-1.	GDPS System Data Flow	2- 3
3-1.	Italian Air Force Geographical Data Processing System.	3- 2
3-2.	GDPS-DS Hardware Configuration.	3- 3
3-3.	DLMS-PS Hardware Configuration.	3- 5

1. INTRODUCTION

1.1 General

This report is the Final Technical Report for the IAF Geographical Data Processing System (GDPS). The information herein is in fulfillment of the obligations set forth in Contract No. F30602-78-C-0278. Companion documents which provide additional, very detailed technical information are:

- a. Geographical Data Processing System Computer Program Documentation Manual (Volumes I and II)
- b. IAF Geographical Data Processing System (GDPS) Design Plan
- c. GDPS Operation Manual
- d. Test Plan/Procedures for IAF Geographical Data Processing System (GDPS)

1.2 Background

In 1976, Synectics developed the Cartographic System, in an effort sponsored by RADC, for the Italian Military Geographics Institute (IGMI). This effort was conducted under the auspices of the joint USAF/Italian Air Force (IAF) Cooperative Research and Development program. The CS was designed to aid in the chart compilation process. With the advent of the Digital Landmass Simulation (DLMS) program, a requirement was placed on all NATO members to collect terrain and planimetric (culture) data over their respective countries. It was decided that, while the CS was adequate for collecting digitized data from charts, it could not support the high degree of processing required to create DLMS digital products. Thus, a second system, the GDPS, would be implemented to support the conversion of digitized output to DLMS formats. In addition, the GDPS would have its own digitizing subsystem, the GDPS-DS to work in parallel with the CS to allow more rapid acquisition of chart inputs.

1.3 Scope

The scope of the IAF-GDPS effort included all activities required to specify, design, fabricate, procure, integrate, and test a hardware and software system which met the functional requirements defined in the Statement of Work. The basic requirement was that the GDPS produce data which is totally compatible with that produced by the DMAAC DLMS processing software. Specifically, this data constitutes two products: terrain and culture input tapes to the DMA Cartographic Data Base. These products

must be constructed according to the following guidelines:

a. Terrain Data Base File Tape:

DMA STANDARD TERRAIN FORMAT (PS/IC/OCTOBER 1977)

b. Culture Data Base File Tape:

DMA STANDARD EXCHANGE FORMAT FOR LINEAR DIGITAL DATA
(MAY 1980)

1.4 Objectives

The objectives of this report are as follows:

- a. To describe the approach and design taken to successfully fulfill the Scope of the effort.
- b. To synopsise the testing/evaluation activity.
- c. To specify additional system enhancements.
- d. To suggest the role which the GDPS (or other similar systems) could fulfill at RADC and at the Defense Mapping Agency (DMA) production centers.

2. SYSTEM OVERVIEW

2.1 Subsystem Concept

As outlined in the Statement of Work, the GDPS is based on a subsystem concept. One subsystem, the GDPS Digitizing Subsystem, GDPS-DS, supports data acquisition of DLMS analyst-prepared inputs. The second subsystem, the DLMS Processing Subsystem, DLMS-PS is used to process GDPS-DS output data into DLMS terrain and culture Cartographic Data Base magnetic tape input files.

2.2 GDPS-DS Role

The GDPS-DS uses prepared chart manuscripts and Feature Analysis Data Table (FADT) information (feature header descriptions for culture data) as input. Processing data through the digitizing and FADT software modules results in the following products being generated:

- a. Digitized Terrain File
- b. Digitized Planimetric (Culture) File
- c. FADT File

The FADT file may be merged with the Culture file at either the GDPS-DS or DLMS-PS. The action of this merging operation results in a culture file in the same format as that of an unmerged culture file.

2.3 DLMS-PS Role

The digitized terrain file or merged/digitized culture file are used as sources to the terrain and culture file software packages respectively. The terrain file is converted to the DMA Standard Terrain Format, and then merged as a subset to a one-degree square coverage file. Once the file has been completed, it may be output to tape as a Cartographic Data Base input. The culture data input is converted to the DMA Standard Exchange Format for Linear Data, after undergoing various reconstruction activities. The file is then converted to tape where it may subsequently be input to the Cartographic Data Base.

The DLMS-PS supports the production of both Level 1 and Level 2 DMA Standard Format products for terrain and culture data.

2.4 Data Flow Description

Figure 2-1 is an illustration describing the GDPS data flow. The flow begins with the receipt of a DLMS manuscript and FADT data sheets (if a culture job is being processed). The chart data is digitized using the GDPSEX digitizing software package. In parallel with this activity, the FADT data is entered on the system through use of a psuedo-text editor. Files result from all of these processes. The files are identified by a job name used to identify the activity session (digitizing or FADT entry). Once these operations are completed, the FADT data file is merged with the digitized file (for culture jobs only). The resultant digitized file, terrain or culture, is output to magnetic tape and subsequently input to the DLMS-PS. Depending on the source type, i.e. culture or terrain, the files are transformed, manipulated, and converted to either of two DMA-specified formats.

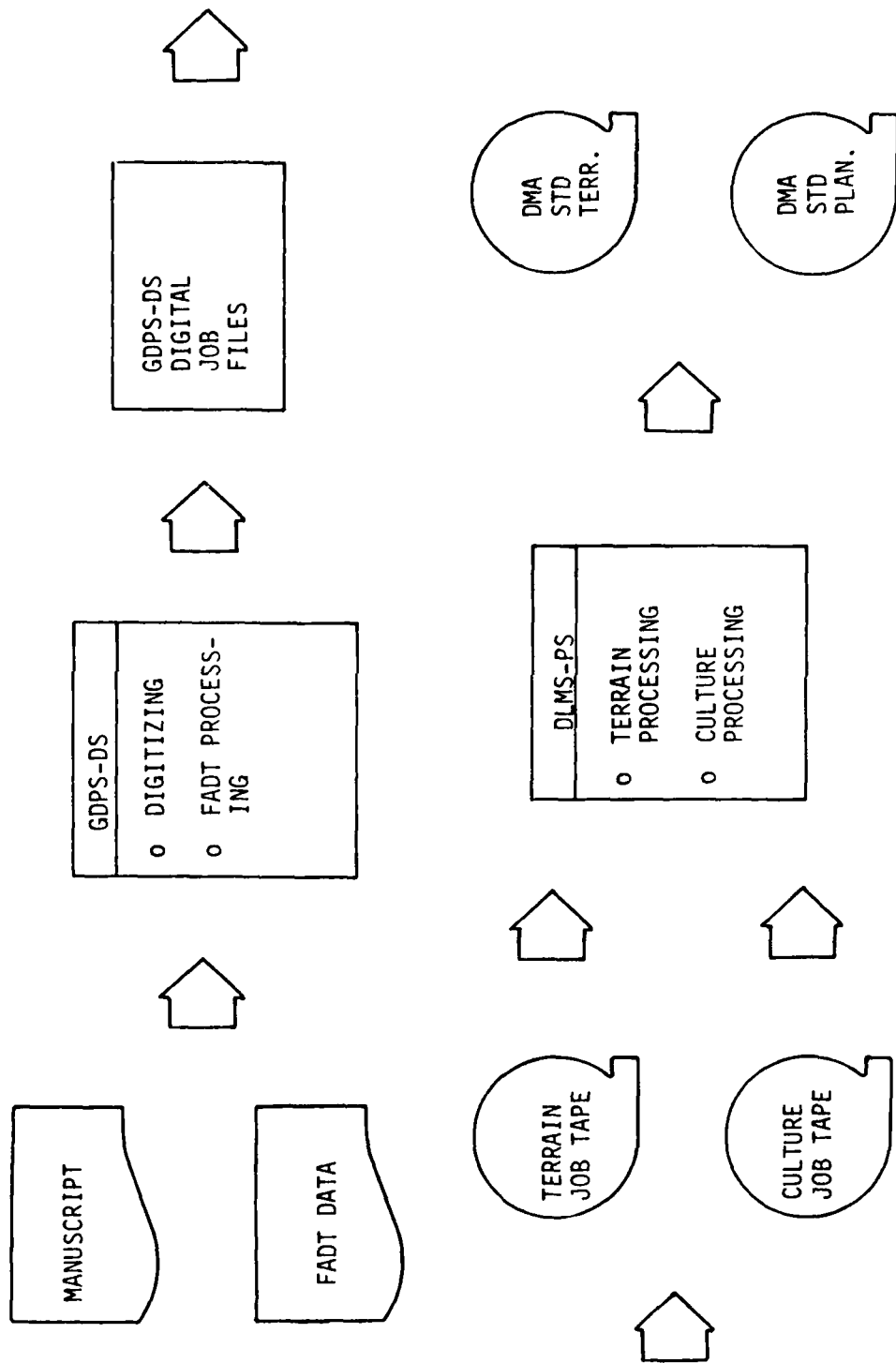

Figure 2-1. GDPS System Data Flow

3. HARDWARE OVERVIEW

3.1 GDPS Subsystem Configuration Concept

The GDPS hardware has been configured as two separate subsystems. The GDPS-DS hardware is intended to support all digitizing activities, while the DLMS-PS hardware will support DLMS digital format conversion processes. Each subsystem is independent of the other. There are built-in compatibilities, however, within the system that allow sharing of hardware resources. They are as follows:

- a. Compatible 7-track magnetic tape units;
- b. Compatible 10-megabyte disk drives which permit the transfer of disk cartridges from one subsystem to the other;
- c. A common plotter which is switch-selectable to either subsystem; and
- d. A common display screen hardcopy unit which can be multiplexed to both subsystem Tektronix display units.

Figure 3-1 illustrates the total GDPS configuration.

3.2 GDPS-DS

The following information pertains to the hardware configuration of the GPDS-DS (Digitizing Subsystem). A roster delineating the hardware illustrated in Figure 3-2 is presented.

The GPDS-DS hardware includes the following components:

- a. Data General ECLIPSE S/130 processor;
- b. 10-Megabyte Disk Cartridge System;
- c. 7-Track 556/800 bpi Magnetic Tape Unit;
- d. 2-Data General Dasher Terminal Printer Consoles;
- e. Data Automation Datatrack 36" x 48" Absolute Digitizing Table;
- f. Tektronix 4014-1 Graphic Display Terminal; and
- g. CALCOMP 1051 Drum Plotter with CALCOMP Microprocessor Interface.

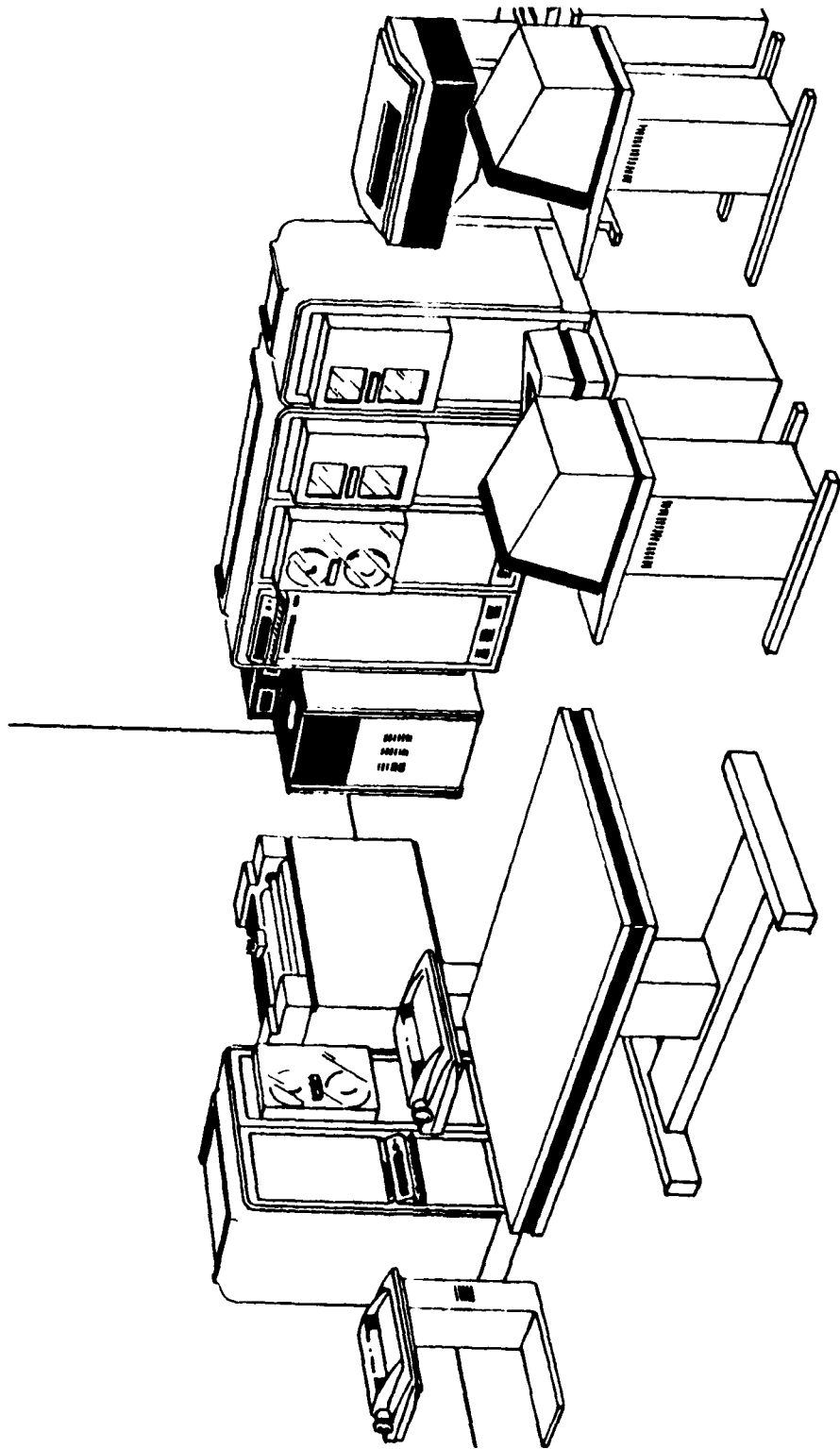

Figure 3-1. Italian Air Force Geographical Data Processing System

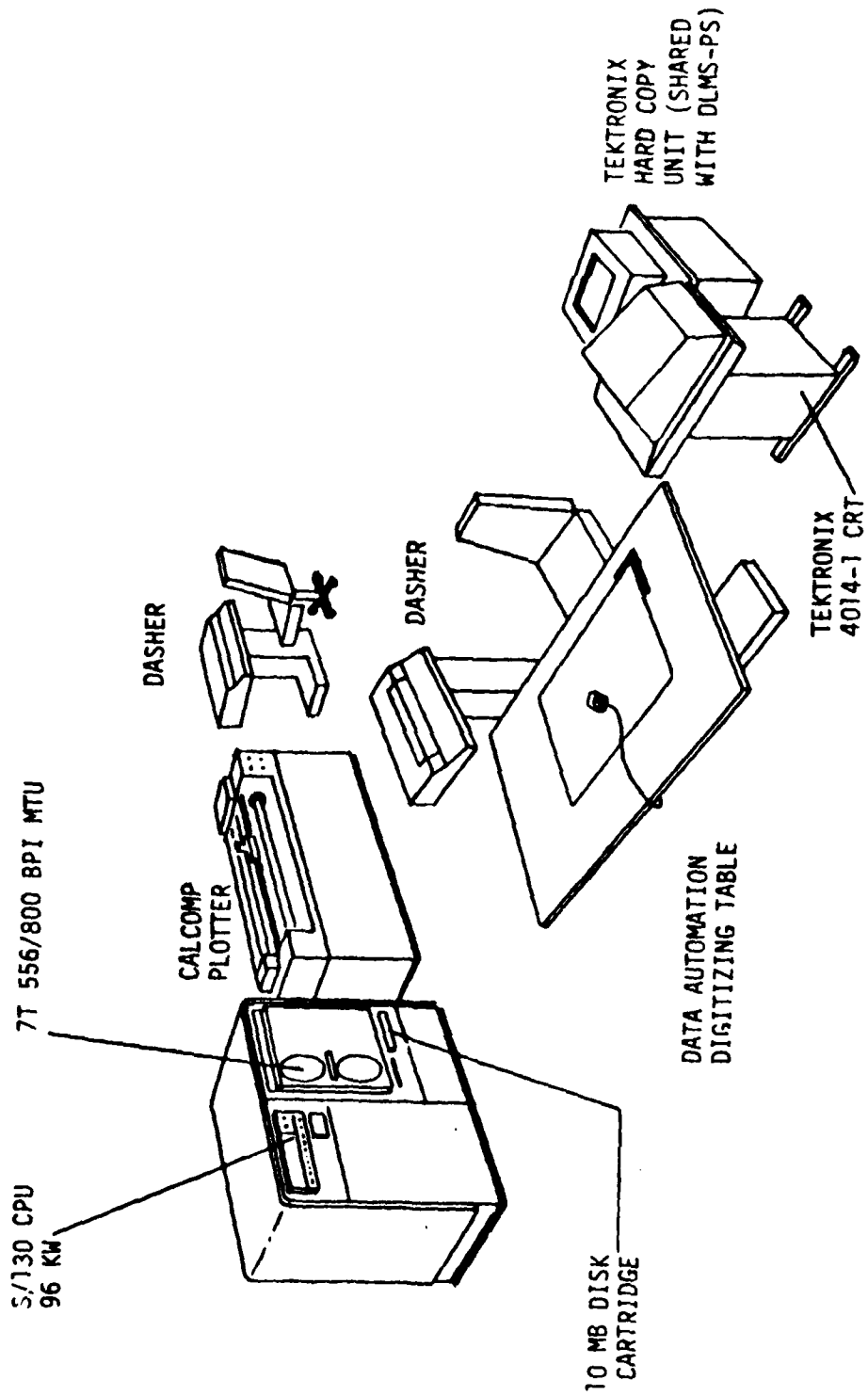

Figure 3-2. GDPS-DS Hardware Configuration

3.3 DLMS-PS

The DLMS-PS hardware configuration (reference Figure 3-3) includes the following components:

- a. Data General ECLIPSE S/250 processor with integral array processor and Floating Point Hardware;
- b. 10-megabyte Disk Cartridge Subsystem;
- c. 7-Track 556/800 bpi Magnetic Tape Unit;
- d. 2 - 9-track 800/1600 bpi Magnetic Tape Units;
- e. Data General Terminal Printer Console;
- f. Data General 300 LPM Printer;
- g. Data General 192 Megabyte Disk Subsystem;
- h. Tektronix 4014-1 Graphic Display Terminal;
- i. Tektronix 4631 Hard Copy Unit (Shared with GDPS-DS); and
- j. CALCOMP 1051 Plotter (shared with the GDPS-DS).

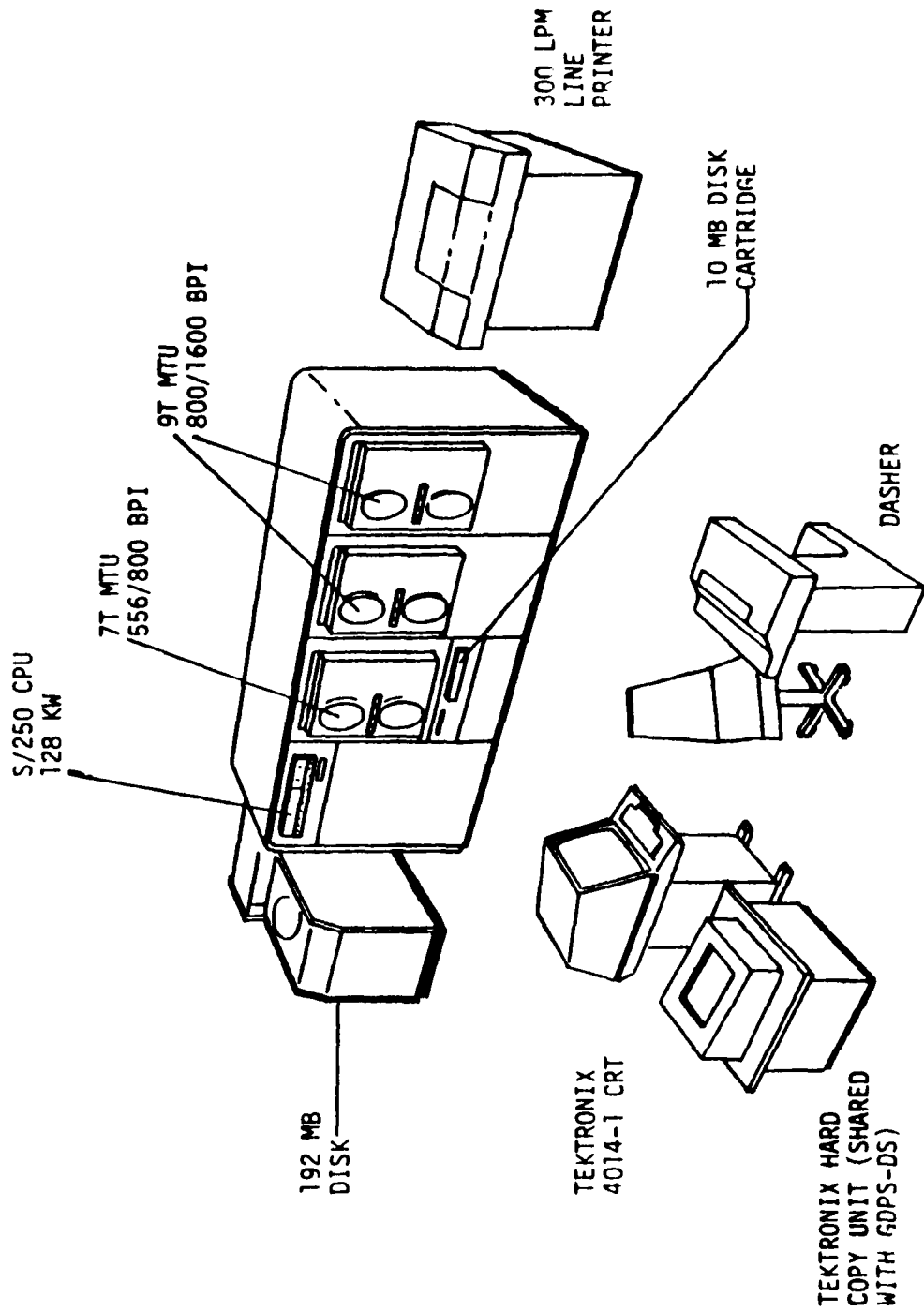

Figure 3-3. DLMS-PS Hardware Configuration

4. FUNCTIONAL OVERVIEW

4.1 GDPS-DS Functions

4.1.1 Digitizing Functions

The digitizing functions are conducted on the GDPS-DS in an interactive environment. Initialization and Registration modes are the first functions performed in a GDPS job session. Depending on whether a new job is to be created or an existing job is to be updated, these functions allow for parameters to be entered or edited and for registration or re-registration to occur.

The Header function is the central mode of operation. From this function, several processing paths are open to the operator for lineal or point digitizing, review, and editing. The transfer of control from one mode of operation to another is performed using the pushbuttons on the digitizing cursor.

4.1.1.1 Initialization

This function determines a job's new/old status and creates or updates a specific job's parameter information. The parameter file resides on disk and is updated with user inputs obtained through prompts on the display terminal. These inputs include Job ID, chart scale, UTM reference points, and other geographic data including corner latitude/longitude coordinates, and UTM zone data among others. After all parameter information is input the user may review and change selected fields.

4.1.1.2 Registration

The registration software sets up the transformation equations necessary for the conversion of data input from the digitizer to the job's geographic frame of reference. This is done by selecting six points on the digitizer-based graphic, associating them with known geographic UTM coordinates and deriving the appropriate equations. The geographic registration is done only once for each chart to be digitized. Transformation coefficients, adjustments and corrections are stored in the job parameter blocks. In addition, registration reference points collected in this function are used by the DLMS processing subsystem to convert from table to geographic coordinates. Subsequent 6-point re-registrations allow for a table-to-table transformation necessary when the table-based manuscript is removed and later remounted.

4.1.1.3 Header

The Header function is used in the assignment of headers and for FAC (Feature Analysis Code) numbers to features prior to their digitization. It is also the central mode of user operation and, through this function, access is made to the Trace, Discrete Point, Review and Edit functions.

Additionally, a menu of auxiliary functions can be accessed. These auxiliary functions allow the user to establish or change selected job parameters during the digitizing session. These parameters include changes in elevation value, contour interval, and display scale.

4.1.1.4 Trace

The Trace function is used to acquire lineal and areal features. The features are stored as lineal data strings. This function accepts an x,y coordinate pair derived from the digitizing table, rounds the point to the nearest multiple of the recording resolution, then packs and stores the data.

Points are input to the Trace function from either continuous stream digitization or an alternate mixed point/continuous digitization method. Each point is displayed on the console screen as it is stored. Exits to the Header and Edit functions are provided through cursor pushbutton logic.

4.1.1.5 Discrete Point

The Point function is used to record discrete point features. Points recorded from the digitizing table are displayed on the display screen relative to their table position. Point labels also appear on the screen. The points are then open to sequential cancellation, if desired. As in the Trace functions, exit to the Header function is provided.

4.1.1.6 Review

The Review function is used to examine features collected within a user-specified area on the digitizing table. Additional capabilities of this function are options to change the display scale, move the display window and exit to the Header mode.

4.1.1.7 Edit

The Edit function provides diverse editing activities which are both feature-dependent and feature-independent. General Edit functions perform initialization of the edit process by locating the user-specified feature, displaying it, determining feature type and permitting header change or feature deletion.

Discrete point features, once located, are drawn on the display screen as a series of plus signs. A square is drawn around the point selected for

editing. Points may be deleted, modified, or added by depressing the appropriate pushbutton on the digitizing cursor. When satisfied with all edits, or at any time in between, the user may redisplay the feature. Exits to Edit or Header modes are provided.

Trace features are displayed on the console screen as continuous line segments. Prefix, suffix, or mid-segment edits may be performed on trace features. As the edit segment is digitized, it is displayed on the screen for verification. Upon completion, the operator is instructed to accept the edit and return to Edit mode; reject the edit and return to Edit mode; or reject the edit and begin digitizing a new edit segment.

4.1.2 FADT Processing Functions

The FADT processing software creates and assigns Feature Analysis Data Table (FADT) descriptors to planimetric features collected in the digitizing process. The FADT processing software consists of two main functions, FADT Entry and FADT Merge.

4.1.2.1 FADT Entry

FADT data consists of radar-significant parameters derived from photographs or other sources and formatted by the feature analyst. The Entry function facilitates input, editing, and review of this data by providing the following capabilities:

- a. creation and update of FADT files;
- b. text-editing support; and
- c. hardcopy output of all or selected FADT's within a file.

4.1.2.2 Merge

The FADT Merge function is used to integrate into the header section of the DLMS feature record the associated entry of the FADT data file. Matches are made between the two files by comparing the FAC (Feature Analysis Code) number of each DLMS feature with the FAC numbers of the FADT entries. Any FADT entries or DLMS features that are not matched are reported and a summary listing of the merged file is produced.

4.1.3 Digitized Data Plots

Verification plots have been developed to help minimize the errors that could occur in the digital input data. The plots consist of terrain or culture file data obtained in the digitizing job session. Plots are output to the Calcomp 1051 Plotter and include annotation indicating file-name and date and time of plot.

4.2 DLMS-PS Functions

4.2.1 Terrain Functions

DLMS terrain processing is the process by which data files containing strings of lineal data from the GDPS-DS are transformed into an elevation matrix. One matrix covers a 1° X 1° area. For every manuscript (data file) received from the GDPS-DS an elevation sub-matrix is built. Each sub-matrix is then merged with other sub-matrices to form the 1° square matrix file. The DLMS-PS terrain processing consists of four major functions as described below.

4.2.1.1 Transformation

The terrain Transformation function is the process by which a terrain job file from the GDPS-DS is converted to an elevation sub-matrix. This process includes:

- a. accepting user inputs needed to set up the sub-matrix file and its associated 1° square matrix filename;
- b. converting UTM northings/eastings to WGS-72;
- c. forming the normal coefficient matrix and solving for polynomial coefficients;
- d. computing grid line numbers in reference to the sub-matrix file; and
- e. storing the converted to WGS-72 elevation data in the appropriate locations of the sub-matrix file.

4.2.1.2 Alteration/Smoothing

Any holes, spikes, anomalies or discrepancies are removed from the manuscript sub-matrix file in the Data Alteration/Smoothing function. The Integrated Array Processor is used extensively by this function. An average elevation for each sub-matrix file record is calculated and used to replace null elevations. Each vertical string of records is examined and a convolution is performed on the string. Data resulting from the convolution is scaled down to cover its original range of elevations.

4.2.1.3 Sub-Matrix Merge

This function merges a user-specified DLMS terrain sub-matrix file into its associated 1° square matrix file. This is accomplished by accepting inputs of the sub-matrix filename and the southwest corner coordinates of the 1 degree square from the user. The appropriate

location in the 1° X 1° matrix file is computed then the sub-matrix data is output to that area.

4.2.1.4 1-Degree Square Output

In this function of the DLMS processing system, the 1° square matrix is output to tape. GDPS-DS terrain data, having been transformed, "smoothed" and merged into a matrix, is formatted according to the DMA Standard for Digital Terrain Data. The formatted data is written to a 9-track tape along with user-supplied header and trailer information.

4.2.1.5 Character Elevation Plot

This function produces an alphabetic character printer plot for verification of a DLMS terrain file. Each alphabetic character represents a specific range of elevations as determined by user inputs. Any grid location which has no elevation will be depicted by a "." on the printer output. Plots may be produced from either a DLMS sub-matrix file before or after the "smoothing" process, or from a 1-degree square file at any time.

4.2.2 Culture Processing

4.2.2.1 Transformation

The culture Transformation function performs the process by which digitized culture data is transformed into absolute geographic coordinates. This function will signal an error condition if the process is executed on anything other than a culture file that has been merged with an FADT file. All digitized table points are converted to WGS-72 geographics then offset to the nearest minute south and west from the southwest corner of the source manuscript. Any feature that crosses a map boundary is "clipped" back to the boundary by means of an interpolation technique using similar triangles. Additionally, DSI (Data Set Identifier) and REG (Registration) records are formatted for subsequent output to tape.

4.2.2.2 String Generation

The culture String Generation function converts the file created in the culture Transformation to DMA Standard Exchange format. The digitized feature oriented file is converted to one that is FAC (feature analysis code) oriented. In this process, strings which belong to more than one physical feature are detected. FAC headers are set up and linked to all strings belonging to that FAC. This method allows duplicate strings to be filtered out of the data at this point. FEA, (Feature Header) SEC (Section), and DAT (Data) records are formatted in this function for output to tape.

4.2.2.3 Output

This function uses the disk files created in the preceding culture functions as input. Since the culture data was previously formatted in the DMA Standard Exchange format, the disk records are simply read then written to the output tape. One culture output file contains data pertaining to one digitized source manuscript as opposed to a terrain output file which contains data in a 1-degree square area.

4.2.2.4 Verification Plots

Two plots are available for verification of culture data processing. Following the Transformation function, the geographics generated as a result of the transformation process may be plotted on the Calcomp plotter for visual verification. Duplicate strings are still present at this point but features will be "clipped" to the manuscript boundaries.

Following the culture String Generation function, another Calcomp plot is available to verify the format and contents of the output data. This plot is also capable of plotting data directly from the culture output tape. At this stage of culture processing any duplicate strings should be removed. Additionally, string ID's and the number of features to which the string belongs are output to the printer.

5. TESTING/EVALUATION

5.1 Test Data

Since the IAF-GDPS was originally intended to support the conversion of Italian manuscript information to digital DLMS products, Synectics attempted to obtain typical Italian charts (IGMI 1:25000 and 1:50000 scale) and Feature Analysis Data Table (FADT) data. When it was learned that these sources were not available within the scheduled timeframe for data analysis and testing/evaluation, Synectics requested, through the RADC Project Engineer, manuscripts and FADT information from the U.S. production centers (DMAAC and DMAHTC).

Manuscripts to support the testing of terrain inputs were furnished by DMAHTC. These manuscripts, or film positives, were supported by lithographic charts, which provided a geographic base. Culture data (overlays and FADT data) were provided by DMAAC.

Several steps were necessary to prepare these sources to a form acceptable to the GDPS. Primarily, the GDPS had been implemented to support processing of Italian-series charts within the geographic locality of Italy.

The geographic transformation modules were then modified to accept the WGS-72 and Tokyo datums instead of the European datum. In addition, the manuscripts selected by Synectics for culture test input did not have a geographic base (no corresponding litho sheets), so Synectics project personnel assigned UTM's and geographic reference points based on the terrain input test data base. Acceptability could then be determined by confirming that the format of the output products matched the DLMS specifications. In addition, using the proof plot facilities of the system would provide a good perspective of the overall data at its various stages of conversion.

5.2 Test Procedures

Testing was accomplished in accordance with the approved Test Plan; that is, both non-operational and operational tests were conducted. Non-operational tests are tests which can be carried out by performing visual inspections, while operational tests are tests which are based on system performance.

Further testing was performed to scrutinize the more salient aspects of the system, such as culture string generation (segments to FAC feature conversion) and array processing support of the data alteration module used in terrain processing.

5.3 Test Results

In all but a few instances, the results generated passed acceptance. In the remaining cases, acceptable results were gained by minor software changes and by a further delineation or clarification of operator instructions. The results were verified by performing data block-to-block comparison with the DLMS product format requirements and visual inspection of output plots.

6. CONCLUSIONS AND RECOMMENDATIONS

6.1 Conclusions

The GDPS has successfully demonstrated that DLMS processing can be effectively performed on a dedicated mini/midi computer consisting of modern off-the-shelf technology. In addition, it has been shown that state-of-the-art architectures, such as array processor augmentation/integration can be exploited very effectively in increasing DLMS processing performance orders of magnitude over conventional main frame computer organization.

An equally important conclusion is that new methods in preparing DLMS data, such as segment digitizing and segment (string) generation to FAC features can eliminate some of the inherent DLMS problems such as overlap/gap occurrences between culture features. New processing approaches lend themselves readily to minicomputer implementation for the following reasons:

- a. there is more interaction between the developer and the computer;
- b. there is less "interference" (resource allocation, scheduling, etc) from other users; and
- c. there would be negligible effect on production schedules, say, on a GDPS-like system at the DMA production centers, since production runs could continue while new processing methods were undergoing development, testing, and evaluation. Once proven, they could be implemented in an operational software package.

6.2 Recommendations

The decision to retain the GDPS at the Experimental Cartographic Facility has put RADC in an excellent posture for future applications and research in digital product processing, supporting diverse MC&G and tactical/strategic requirements. The remaining pages of this report are recommendations to fully exploit the features of the GDPS and bring to the surface the latent capabilities of the system hardware and software.

6.2.1 "Americanization" of the GDPS

The GDPS was designed to handle the IGMI Carto d'Italia series 1:25000 and 1:50000 chart inputs. A UTM registration was used based on the European Datum and International Ellipsoid. In order to handle typical American charts, the registration software should be supplemented

as follows:

- a. The inclusion of more chart scales;
- b. More projections, such as Mercator, Lambert Conformal, and Gnomonic;
- c. Additional models, such as Clark 1866, etc., Bessel, and WGS-72/80.

Corresponding modifications would be made to the DLMS culture and terrain transformation modules to accept these inputs.

6.2.2 Analysis of GDPS Products

Once the GDPS was "Americanized" a thorough study of its capabilities could be conducted using many sources comparable to those used for input at DMA production centers. Accuracy and performance characteristics could be systematically checked using both Level 1 and Level 2 data.

6.2.3 Analysis of DLMS Products

The GDPS is the logical facility for further research and development of DLMS products and specifications. The culture format used by the GDPS was designated as a draft specification. Further refinements could be developed and tested on this system without adversely affecting ongoing production at the Centers.

6.2.4 Test Data Base Generation

RADC can use the GDPS to build an in-house DLMS Carto Data Base. This CDB can support the testing and evaluation of ongoing and future tactical and strategic applications efforts in an environment offering more control and faster response since data base files can be accessed locally or be generated in parallel with the project software.

6.2.5 GDPS Utilization at the DMA Production Centers

The Cartographic Processing System (CPS), which is intended to boost the production rate of DLMS Culture data base files, is currently under development and is an estimated two to three years away from production level. In the interim, a system such as the GDPS could be used to provide rapid throughput of ad hoc DLMS products requiring high priority without affecting the normal UNIVAC 1110 production processing.

6.2.6 C³I Requirements

RADC has been designated by AFIS as the responsible agency for determining map accuracies, precision, and applicability for strategic and tactical weapons requirements. GDPS system elements (hardware and software modules) are ideal building blocks in constructing new products or product modifications and in evaluating the degree of support those products furnish in meeting these requirements.

MISSION
of
Rome Air Development Center

RADC plans and executes research, development, test and selected acquisition programs in support of Command, Control Communications and Intelligence (C³I) activities. Technical and engineering support within areas of technical competence is provided to EST Program Offices (POs) and other ESD elements. The principal technical mission areas are communications, electromagnetic guidance and control, surveillance of ground and aerospace objects, intelligence data collection and handling, information system technology, ionospheric propagation, solid state sciences, microwave physics and electronic reliability, maintainability and compatibility.

