

Advanced Electronic Fuel Injection Systems – An Emissions Solution for both 2- and 4-stroke Small Vehicle Engines

Mark Archer, Greg Bell

Synerject Systems Integration, Balcatta, Australia

ABSTRACT

This paper describes two advanced electronic fuel injection systems for small vehicles which have recently become commercially available. Both systems have been designed and developed by the authors' organisation.

One of the two systems ('aSDI') has been designed and developed for 2-stroke engines and the other ('SePI') for 4-stroke engines. Both systems are intended for application on small vehicles fitted with small 1 – 2 cylinder gasoline engines of displacement 50 – 250 cm³ per cylinder. Typical examples of such small vehicles are: ATV's (All Terrain Vehicles), auto-rickshaws, motorcycles, motorscooters and mopeds¹.

Fuel consumption and emissions results from both systems are presented, and in both cases it is shown that engine-out exhaust emissions meet current and future limits in Europe, India and Taiwan, without the need for exhaust after-treatment. It is also shown that both systems offer significant fuel savings relative to otherwise-equivalent, carburetted baseline vehicles.

Other important benefits of these systems which are discussed in this paper are improved cold start and improved driveability.

The paper also includes a short overview of the performance and cost implications of both systems relative to alternative emissions control methods.

¹ For reasons of convenience, these types of vehicles will be referred to collectively as 'small vehicles' in this paper.

1. INTRODUCTION

During the last 30 years or so, reductions in tailpipe exhaust emissions of more than 90% have been demanded of, and achieved by the automobile industry [1], with one of the most important enabling technologies being low-cost, series-production EFI (Electronic Fuel Injection).

Relative to carburetted fuel systems, the main mechanisms by which EFI has helped to reduce exhaust emissions are as follows:

- 1) Reduced wall wetting.
- 2) Improved fuel atomisation.
- 3) Greater flexibility in A/F (Air/Fuel ratio) control, which in turn has facilitated:
 - Improved warm- and cold-start emissions.
 - Reduced transient emissions.
 - Increased lean A/F operation.
 - High conversion-efficiency exhaust after-treatment.
- 4) Improved unit-to-unit repeatability.

In addition to reduced exhaust emissions, EFI has also introduced other benefits such as reduced brake-specific fuel consumption, increased full-load output and improved driveability [2].

As a result of this reduction in automobile exhaust emissions, it is now often smaller vehicles such as auto-rickshaws, motorcycles, motorscooters and mopeds which are becoming responsible for an increasingly significant proportion of the HC (unburnt hydrocarbons) and CO (carbon monoxide) exhaust

emissions burden in some urban environments. In the EU for example, two- and three-wheeled motor vehicles are currently believed to be responsible for around 5 – 10% of overall HC and CO emissions, and it is anticipated that this proportion will increase to 15 – 20% by the year 2020 [3].

In some large Asian cities, the situation is already more serious; the high popularity of motorcycles in Taiwan for example, means that they are currently believed to be responsible for approximately 30% of overall HC and 40% of overall CO emissions [4].

Increased attention is therefore now being paid to reducing exhaust emissions from small vehicles, and one obvious means of achieving such a reduction is to apply EFI technology from the automotive sector.

When considering the small vehicle market relative to the automobile market however, one key difference immediately becomes apparent; namely: cost. This 'cost' issue manifests itself in two very important ways as follows:

- 1) In the small vehicle market, the maximum allowable piece cost of an emissions reduction system, is smaller than in the automobile market (by approximately one order of magnitude).
- 2) The incremental investment cost of a new technology which will be tolerated by the small vehicle industry is also much smaller than in the automobile industry.

The need for cost-effective emissions solutions in the small vehicle industry is therefore widely recognised, and, as outlined in the following section, a number of alternative low-cost strategies are currently being pursued.

The strategy detailed in this paper involves the application of advanced electronic injection systems: Direct-Injected (DI) in the case of 2-stroke engines and Port-Injected (PI) in the case of 4-stroke engines. Although higher in piece cost than some alternative systems, we believe that such systems offer a better overall cost / benefit balance (i.e. when piece cost, production cost, operational, reliability, environmental, and other issues are all taken into account).

The aims of this paper are therefore:

- 1) To provide a brief description of the Synerject 2-stroke and 4-stroke fuel injection systems.
- 2) To present test results and other information which help give a better understanding of the overall cost / benefit balance offered by both systems.

The 2-stroke system described in this paper became available to the public for the first time in June 2000 on the Aprilia 'DITECH' SR 50 motorscooter (Figure

1) and will soon appear on a number of other small vehicle models produced by a variety of manufacturers worldwide.

Public response to the Aprilia DITECH SR50 motorscooter has been very positive with most significant operating benefits being [5]:

- 'Real world' fuel consumption benefit of 40%.
- Negligible exhaust smoke emissions.
- Improved cold-start.
- Improved driveability.
- Oil consumption reduced by more than 50%.
- Oil 'top-up' service interval increased to 4,000 km.

Figure 1 - Aprilia DITECH SR50 motorscooter



The 4-stroke system described in this paper is due to be released to the public in 2001.

2. ALTERNATIVE EMISSIONS REDUCTION METHODS FOR SMALL VEHICLES

This section includes a brief description of the main emissions reduction methods currently being used and/or considered for use by the small vehicle industry. The advantages and disadvantages associated with these various emissions reduction methods are summarised in Table 1 and Table 2. These methods are as follows:

Table 1 – Comparison of different emissions control systems for small vehicle 2-stroke engines

Attribute	Fuel consumption & CO ₂ emissions	CO emissions	HC + NOx emissions	Emissions durability (catalyst aging / misfire)	Specific torque & power (Acceleration)	Cold start	Driveability	Maintenance (Oil / oil filter servicing)	Incremental piece cost * – relative	Incremental investment cost * – relative	Key	
System												
2-stroke carburettor (Baseline):	(=)	(=)	(=)	(=)	(=)	(=)	(=)	(=)	0.0	0.0	xx	Much worse
Oxidation catalyst:	=	✓	✓	✗	✗	=	=	=	0.3	0.5	✗	Worse
Replace with 4-stroke:	✓	✗	✓	✓	xx	=	✓	✗	1.0	2.0	=	Equal
2-stroke electronic injection ('aSDI'):	✓✓	✓	✓	✓	=	✓	✓✓	✓	1.0	1.0	✓	Better
'aSDI' + oxidation catalyst:	✓✓	✓✓	✓✓	✓	=	✓	✓✓	✓	1.3	1.5	✓✓	Much better

* Indicative cost increment only for 10,000 units per annum – actual costs vary significantly from market to market
 Data sources: [3], [5], [6] & [7] plus internal cost estimates

Table 2 - Comparison of different emissions control systems for small vehicle 4-stroke engines

Attribute	Fuel consumption & CO ₂ emissions	CO emissions	HC + NOx emissions	Emissions durability (cat. aging / tampering)	Specific torque & power (Acceleration)	Cold start	Driveability	Maintenance (SAI valve inspect/clean)	Incremental piece cost * – relative	Incremental investment cost * – relative	Key	
System												
4-stroke carburettor (Baseline):	(=)	(=)	(=)	(=)	(=)	(=)	(=)	(=)	0.0	0.0	xx	Much worse
SAI (Secondary Air Injection):	=	✓	✓	✗	=	=	=	✗	0.5	1.0	✗	Worse
SAI + oxidation catalyst:	=	✓✓	✓✓	✗	=	=	=	✗	0.8	1.5	=	Equal
4-stroke electronic injection ('SePI'):	✓	✓	✓	✓	✓	✓	✓	=	1.0	1.0	✓	Better
'SePI' + Three-Way Catalyst (TWC):	✓	✓✓	✓✓	✓	✓	✓	✓	=	1.3	1.5	✓✓	Much better

* Indicative cost increment only for 10,000 units per annum – actual costs vary significantly from market to market
 Data sources: [3] & [6] plus internal cost estimates

2.1 SUBSTITUTE CARBURETTED 4-STROKE ENGINES FOR CARBURETTED 2-STROKE ENGINES.

Relative to carburetted 2-stroke engines, the main benefits offered by carburetted 4-stroke engines are:

- Misfire-free operation.
- Reduced fuel consumption and CO₂ emissions.
- Reduced HC emissions.
- Improved driveability

However, this is a relatively high piece and investment cost strategy, which is sometimes driven more by the 'clean' image of 4-strokes relative to 2-strokes, rather than an objective consideration of state-of-the-art 2-stroke and 4-stroke engine performance per se.

While this 'substitution' strategy successfully eliminates the high levels of HC, smoke and odour emissions typically associated with carburetted 2-stroke engines, the engine-out CO and NO_x (Nitrogen Oxide) emissions are usually higher, and because of the difference in specific output between 2-stroke and 4-stroke engines, a larger, heavier and more expensive 'substitute' 4-stroke engine is normally required to maintain an equivalent level of performance.

2.2 FIT EXHAUST AFTER-TREATMENT CATALYSTS.

Because small vehicles are only responsible for a relatively low proportion of overall NO_x emissions (estimated to be less than 3% [3] [4]), oxidation-only catalysts are usually fitted to small vehicle engines. In the case of 4-stroke engines, these catalysts are used principally to control CO emissions, while in the case of 2-stroke engines they are used to treat both HC and CO emissions. The main advantage of this strategy, is that it is one of the cheaper means of achieving compliance with current emissions legislation, if the base engine is a carburetted 2-stroke [3] [6].

Although attractive from the perspective of low piece and investment cost therefore, catalysts offer no reduction in fuel consumption or CO₂ emissions, and are susceptible to deterioration, particularly on carburetted 2-strokes due to the large quantity of unburnt fuel and oil in the exhaust [8].

Catalyst fitment also increases exhaust temperature and back-pressure, and, particularly in the case of 2-stroke engines, peak power output can be significantly reduced as a result. In the absence of periodic emissions testing, the effectiveness of this strategy can also be reduced by tampering (e.g. intentional modification and/or removal).

The anticipated, widespread introduction of emissions durability requirements and/or 'cold-start' emissions testing will make small vehicle catalyst durability and 'light-off' more important issues than is currently the case.

2.3 SECONDARY AIR INJECTION (SAI).

This technique is now being increasingly applied to small vehicle 4-stroke engines as a means to reduce CO, and to a lesser extent, HC. Usually a 'passive' reed valve system is used; i.e. negative pressure pulses in the exhaust system are used to draw fresh, filtered air into the exhaust stream, immediately downstream of the exhaust valve. The main advantage of this strategy, is that it is one of the cheaper ways of achieving compliance with current emissions legislation if the base engine is a carburetted 4-stroke [3] [6].

Potential problems with such systems include backfiring [6] and carboning of the reed valve. To ensure continued system function, periodic inspection and/or cleaning of the reed valve(s) is usually recommended (for motorcycles: typically every 5,000 – 6,000 km).

'Passive' SAI is not well suited to carburetted 2-stroke engine applications, due to the following reasons:

- 2-stroke engines rely on negative exhaust pressure pulsations to help scavenge the combustion chamber. If these pulsations are instead used to draw fresh air into the exhaust stream, cylinder scavenging (and thus engine performance) can be compromised.
- On a carburetted 2-stroke engine, unburnt HC are generated mostly as a result of the intake charge 'short-circuiting' to the exhaust port during scavenging. By definition however, this 'short-circuited' charge will contain both unburnt HC and unburnt air. As a result, adding extra air to such a mixture achieves little in it's own right.
- In the case of 'combined' SAI / oxidation catalyst systems, passive SAI can result in excessive catalyst temperature with reduced catalyst and muffler durability as a result [9].

2.4 APPLY ADVANCED ELECTRONIC FUEL INJECTION SYSTEMS.

This is the strategy advocated by Synerject for both 2-stroke and 4-stroke engines, and the one which will be detailed in the remainder of this paper. Although higher in piece cost than either oxidation catalysts or SAI systems (refer Table 1 and Table 2), by offering significantly reduced fuel consumption and increased riding pleasure in addition to very low engine-out exhaust emissions, we believe that such systems offer the best of all worlds to both manufacturer and end user on an overall cost / benefit basis.

Of course, certain combinations of the various methods described above can also be implemented. For example, both 2-stroke and 4-stroke electronic injection systems have been successfully combined with exhaust catalysts, and in the medium term it is anticipated that such systems will become 'standard' as emissions requirements become more stringent [7]. 'Combined' fuel injection / catalyst and SAI / catalyst systems have therefore also been included in Table 1 and Table 2, for comparison purposes.

Note that catalyst fitment has much less effect on the performance of a DI 2-stroke engine relative to a carburetted 2-stroke engine; because DI produces far less engine-out HC and CO emissions, and catalyst temperature / back-pressure are considerably reduced as a result.

On small vehicle 4-stroke engines, electronic injection systems can be combined with an Exhaust Gas Oxygen (EGO) sensor and Three-Way Catalyst (TWC) to facilitate simultaneous treatment of HC, CO and NOx emissions as is currently done in the automobile industry.

3. OVERVIEW – 2-STROKE VS. 4-STROKE SYSTEMS

The 2-stroke and 4-stroke electronic injection systems presented in this paper are similar in many respects. Both are intended for fitment to 1 – 2 cylinder gasoline engines of 50 – 250 cm³ swept volume, and consequently share many of the same components. However, the two systems also differ in a number of important respects, the most significant difference being that the 2-stroke system is a DI (Direct Injection) system, whereas the 4-stroke system is a PI (Port Injection) system.

Table 3, Table 4 and Table 5 list the key components of both systems and schematic diagrams of both systems are shown on Figure 2 and Figure 3.

Of course, DI can be applied to gasoline 4-stroke engines also; since 1996 four major auto manufacturers have released engines of this type to the market, and many others have indicated that they are developing engines of this type for near-term market release [10]. The main driver for this change is the reduced fuel consumption available (typically 10 – 20% better than an otherwise-equivalent PI 4-stroke engine), in conjunction with low engine-out NOx [11] [12]. In light of this development, a logical question is: "Why not apply DI to small vehicle 4-stroke engines also ?"

Table 3 - Engine management sub-system - key components

Component	'aSDI' 2-stroke system	'SePI' 4-stroke system
ECU	✓	✓
Integrated throttle body / Throttle Position Sensor (TPS)	✓	✓
IAV (Idle Air Valve)		✓
Electronic Ignition – High Energy Inductive (HEI) coil	✓	✓
Engine crank sensor	✓	✓
Engine temperature sensor	✓	✓
Vehicle speed sensor	Optional	Optional
Ambient air pressure sensor	Optional	Optional
Immobiliser	Optional	Optional
Electronic oil pump	Optional	
'CO potentiometer' *	Optional	Optional

** This function can be carried out by means of a diagnostic / service tool if required.
(Refer section: 'Diagnostics and Servicing' below).*

Table 4 - Fuel sub-system - key components

Component	'aSDI' 2-stroke system	'SePI' 4-stroke system
Fuel injector	✓	✓
Fuel pump	✓	✓
Fuel regulator	✓	✓
Fuel filter	✓	✓
Air injector	✓	
Air compressor	✓	
Air/fuel rail	✓	
CVP valve	Optional	Optional

Table 5 - Combustion sub-system - key components

Component	'aSDI' 2-stroke system	'SePI' 4-stroke system
Modified cylinder head	✓	
Long-projection spark plug	✓	
Modified piston	Optional	

Figure 2 - System schematic - 'aSDI' 2-stroke electronic injection

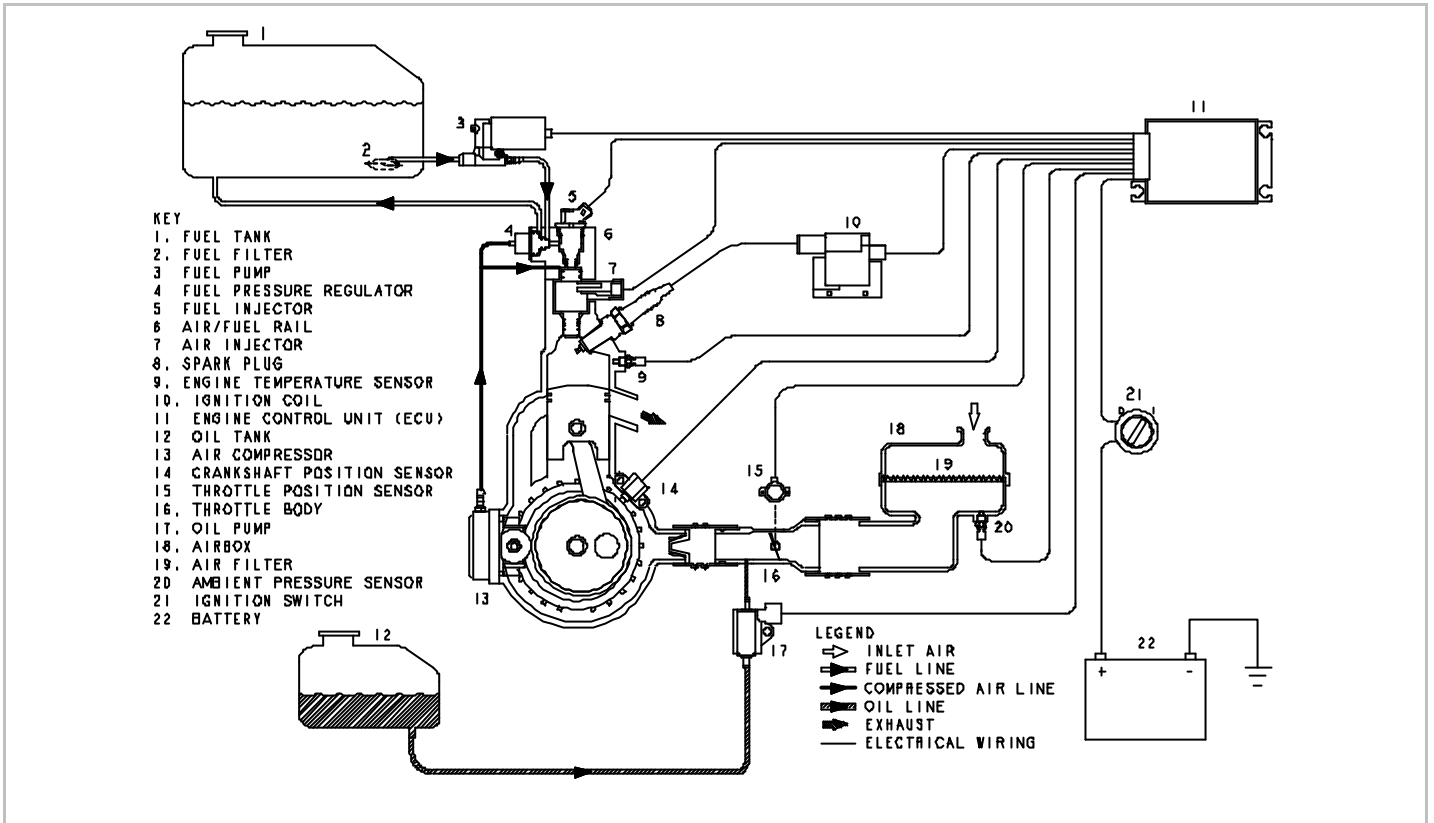
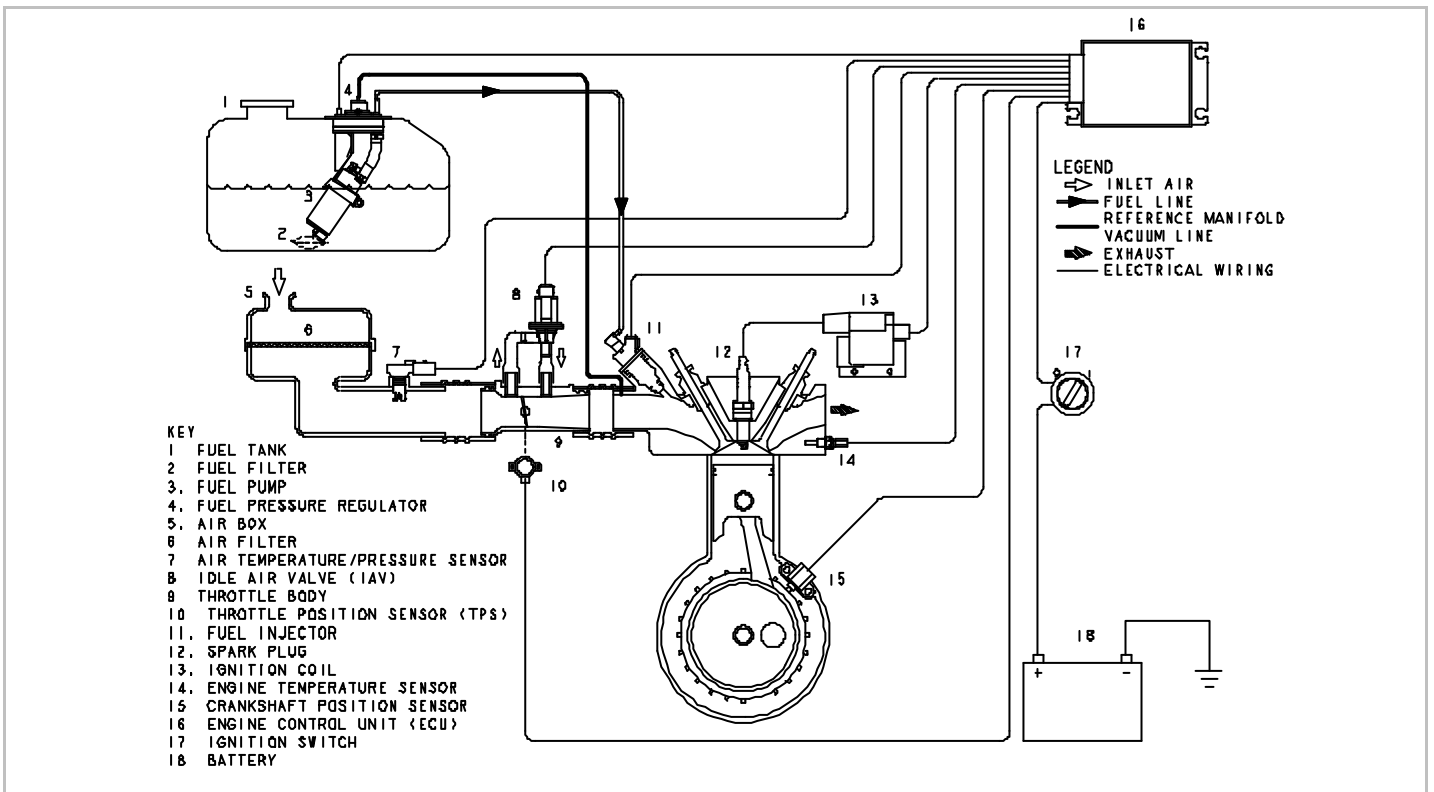

Figure 3 - System schematic - 'SePI' 4-stroke electronic injection



In fact, a development of this type does seem likely in the medium term, as small vehicle fuel consumption and exhaust emissions continue to assume still greater importance. In the current small vehicle market environment however, demand for DI 4-stroke engines is tempered relative to the automobile market by the following factors:

1) Increased emphasis on system low cost.

As discussed in the 'Introduction' section above.

2) Component availability.

To fully exploit the combined emissions / fuel consumption benefits offered by DI relative to PI on a 4-stroke engine, the in-cylinder gas/fuel ratio should be lean, but not unthrottled. On a passenger car engine, this 'controlled enleanment' is readily achieved by means of an ETB (Electronic Throttle Body) and/or EGR (Exhaust Gas Recirculation). Although not yet widely available in the small vehicle industry, such components are standard fitment on many modern automobiles, and in relative terms, DI 4-stroke application is cheaper and easier as a result.

3) Low demand for reduced engine-out NOx.

Small vehicle emissions legislation in many countries has been written with the aim of encouraging more widespread use of 4-stroke engines at the expense of (carburetted) 2-stroke engines. Because 4-stroke engines generally produce more NOx than 2-stroke engines, the emissions legislation 'push' towards low NOx in the small vehicle market is currently weaker than in the passenger car market, and so there is little demand to exploit the reduced engine-out NOx emissions available with DI 4-stroke engines as a result.

The above arguments explain why PI is currently preferred to DI for small vehicle 4-stroke engines; so why not use the same system on small vehicle 2-stroke engines also?

The short answer to this question is: "cost / benefit"; on a 2-stroke engine, the cost / benefit offered by DI is much more favourable than that offered by PI as a result of the much larger fuel consumption and emissions benefits available. The main reason for this difference is that, relative to a carburettor, DI is able to drastically reduce 2-stroke charge losses during scavenging (to the point where engine-out HC emissions are on-par with a 4-stroke engine of similar displacement), whereas PI can only offer a limited improvement (relative to a carburettor) in this respect.

Because of the fundamentally different cylinder charge processes of 2-stroke versus 4-stroke engines, DI-2-stroke fuel systems are also simpler and cheaper than

their 4-stroke counterparts. As demonstrated by the test results presented in this paper for example, large improvements in fuel consumption, HC and CO can be achieved without electronic gasflow control components (such as ETB's and/or EGR).

The main benefits offered by PI on a 2-stroke engine are: reduced fuel consumption (typically by around 10%), improved cold start and improved warm-up; however, these benefits are available with DI to an even greater extent.

Because of improved combustion stability, DI 2-stroke NOx emissions are often higher than those from an otherwise equivalent carburetted (or PI) engine, however, the NOx emissions from 2-stroke engine are low in any case, and even on a DI 2-stroke engine, engine-out NOx emissions are typically:

- Less than the NOx emissions produced by a carburetted 4-stroke engine of similar displacement.
- Up to an order of magnitude smaller than HC emissions in massflow terms.
- Well within current and expected legislated limits (see below).

4. SYSTEM DESCRIPTION – 2-STROKE SYSTEM ('aSDI')

A schematic diagram of the DI 2-stroke system, known as 'aSDI' (air-assisted Synerject Direct Injection), is shown on Figure 2 above. This system is based on the well-known, air-assisted, direct-injection Orbital Combustion Process (OCP), which was first released to the general public in 1996 [13] [14], and has since been applied to a number of engines in a variety of markets worldwide.

Key features of OCP are:

- The use of low-pressure compressed air (as opposed to high fuel pressure) to achieve fuel atomisation.
- The ability to generate an in-cylinder air/fuel 'cloud' consisting of very fine droplets.
- High tolerance to in-cylinder 'residuals' (i.e. retained exhaust gas), by virtue of the injected air.
- Separation of fuel metering and in-cylinder injection functions; these are performed by the fuel injector and 'air injector' respectively (refer Figure 4). This 'division of responsibilities' facilitates a number of important performance benefits including: increased fuel cloud shaping flexibility, greater deposit immunity and reduced system cost.

Figure 4 - OCP fuel and air injectors – typical arrangement

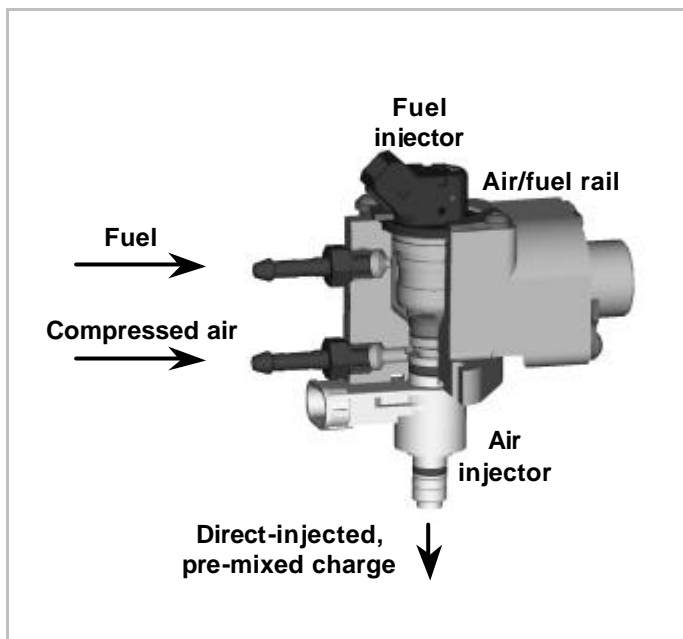

In order to further reduce system cost however, the 'aSDI' system has been significantly simplified relative to the OCP systems currently used on other series-production 2-stroke applications [13]. Key changes in this respect are:

- 1) The 'aSDI' air compressor is run directly off an eccentric on the crankshaft (Figure 5); other applications on larger engines typically use a belt- or gear-driven compressor.

Figure 5 – 'Direct acting' compressor drive

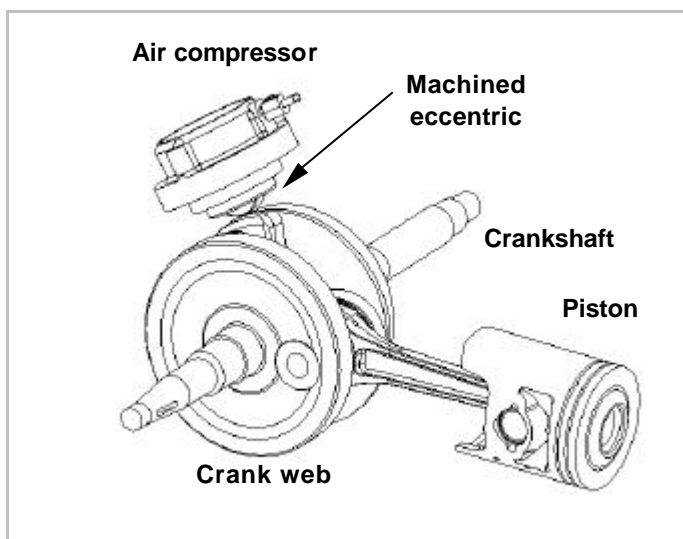

- 2) The 'aSDI' compressed air system does not include an air pressure regulator.

- 3) Key system-specific components such as the ECU and fuel pump have been re-designed and developed to suit the reduced size, cost and complexity requirements of the small vehicle market.
- 4) The complete 'aSDI' system has been designed to minimise electric current consumption, commensurate with the limited electrical power generation capacity available on most small vehicles.

Note that 'aSDI' also differs in a number of important respects from the OCP-based motorscooter system previously presented in [15]. Whereas the earlier system used a FMP (Fuel Metering Pump) for fuel delivery and metering, 'aSDI' now uses a more conventional automotive fuel delivery system with electric fuel pump, (re-calibrated) automotive fuel regulator and (re-calibrated) automotive fuel injector. This change was implemented due to the following reasons:

- Improved response to step changes in driver demand.
- Reduced development and investment costs.
- Increased customer confidence.
- Reduced commercial risk.

Two key components which were required to enable this change were:

- 1) The fuel injector.
- 2) The fuel pump.

These components, along with some of the other system-specific components used by 'aSDI' are described in greater detail below.

5. SYSTEM DESCRIPTION – 4-STROKE SYSTEM ('SePI')

A schematic diagram of the 'SePI' (Synerject electronic Port Injection) PI 4-stroke system is shown on Figure 3.

Relative to contemporary automobile PI systems, the 'SePI' system offers both reduced cost and reduced functionality, in accordance with the demands of the small vehicle market.

Key differences between 'SePI' and a contemporary automotive PI system are as follows:

- 'SePI' has been designed and developed specifically for application to small vehicle 1 – 2 cylinder gasoline engines. Unnecessary automotive functionality (e.g. extra inputs and drivers such as those required for additional cylinders, EGR, electronic throttle control and/or transmission control) have not been included.

- The same, low-cost ECU is used as is used for 'aSDI'.
- Like 'aSDI', 'SePI' also uses a low-cost, low-flow, high-efficiency electrical fuel pump.
- Like 'aSDI', care has been taken to minimise electrical current consumption of the overall 'SePI' system.

The result is a 4-stroke PI system that can be implemented with reduced investment cost, but still offers the performance necessary to meet current and future customer and legislative demands in the small vehicle market.

6. COST REDUCTION STRATEGIES

With both 'aSDI' and 'SePI' systems, piece and investment costs have been minimised by means of the following strategies:

- The functionality of both systems has been reduced to meet only the requirements of the small vehicle target market.
- Modifications to the base vehicle have been minimised.
- Unnecessary differences between applications have been eliminated wherever possible (e.g. 'aSDI' and 'SePI' share many common components and control strategies).
- High-volume, off-the-shelf components have been used where possible (e.g. temperature, pressure, crankangle and throttle position sensors; 'aSDI' oil pump).
- Re-calibrated automotive components have been used in preference to 'clean sheet' designs where practicable (e.g. IAV, fuel injectors and regulators).
- Where necessary (e.g. ECU and fuel pump), the most cost-effective solution has been to design a new system-specific component, tailored to suit the requirements of the small vehicle market, rather than attempting to modify existing automotive components.
- All necessary system components (both system-specific and non-system-specific) are sourced and/or manufactured in high volume by 'Synerject', an Orbital Engine Corporation / Siemens Automotive joint venture company, established for this purpose in 1997.

7. KEY SYSTEM-SPECIFIC COMPONENTS

7.1 ENGINE CONTROL UNIT (ECU)

Figure 6 - ECU external appearance

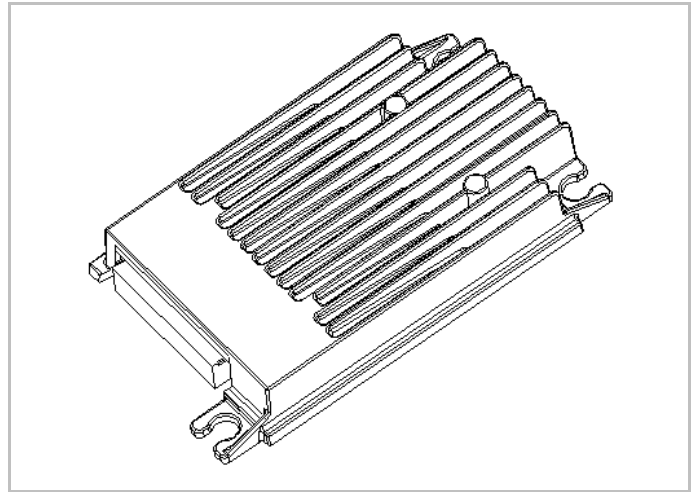

Both 'aSDI' 2-stroke and 'SePI' 4-stroke systems are controlled by an ECU developed specifically for small vehicle applications. Relative to a depopulated automotive ECU, this unit offers reduced size, cost and electrical power consumption. Key ECU requirements are summarised in Table 6.

Table 6 – ECU size, weight & performance

Attribute		Requirement
CPU		8 bit / 8 MHz
Mask ROM (kB)		32
RAM (kB)		1.0
EEPROM (kB)		2.5
Connector		22 pin
Size (mm)	Length	150
	Width	100
	Height	20
Mass (g)		~ 300

7.2 FUEL INJECTORS

Both 'aSDI' and 'SePI' systems use re-calibrated 'Siemens' automotive fuel injectors (refer Table 7 for a list of key requirements).

Table 7 – Fuel injector requirements

Attribute	Requirement	
	'aSDI' 2-stroke system	'SePI' 4-stroke system
Normal differential pressure (Bar)	2.5	
Typical flow rate (g/sec)	< 7.5 kW engines	0.7
	7.5 – 15 kW engines	1.5
Voltage – nominal (V)	14	
Voltage – range (V)	8 – 18	
Injector type	Side-feed (Siemens 'Deka 2')	Top-feed (Siemens 'Deka 1D')
Mounting position	Air/fuel rail	Inlet manifold

Figure 8 - Mounting of 'SePI' fuel injector to inlet manifold

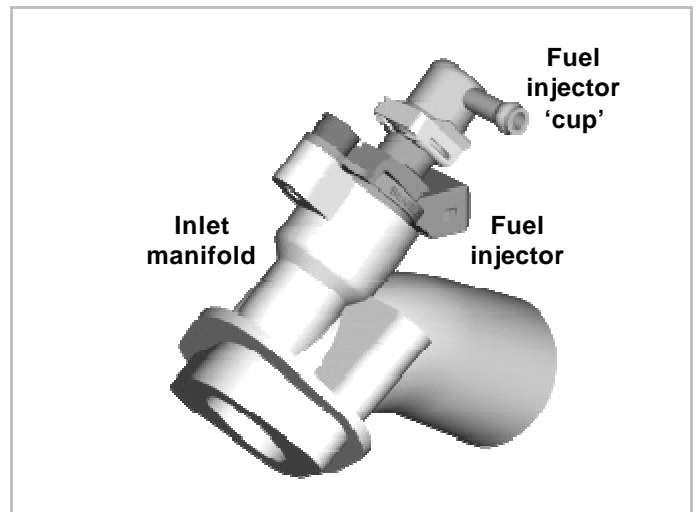

In the case of 'aSDI', both the fuel injector and fuel regulator are mounted on the air/fuel rail, which also holds the 'air injector' (see below) to the cylinder head – refer Figure 7.

In the case of SePI, the fuel injector is mounted to the inlet manifold, and is aimed at the back of the inlet valve(s) in accordance normal PI design practice – refer Figure 8.

Figure 7 – Mounting of 'aSDI' fuel injector and fuel regulator to air/fuel rail (which also holds air injector to cylinder head)

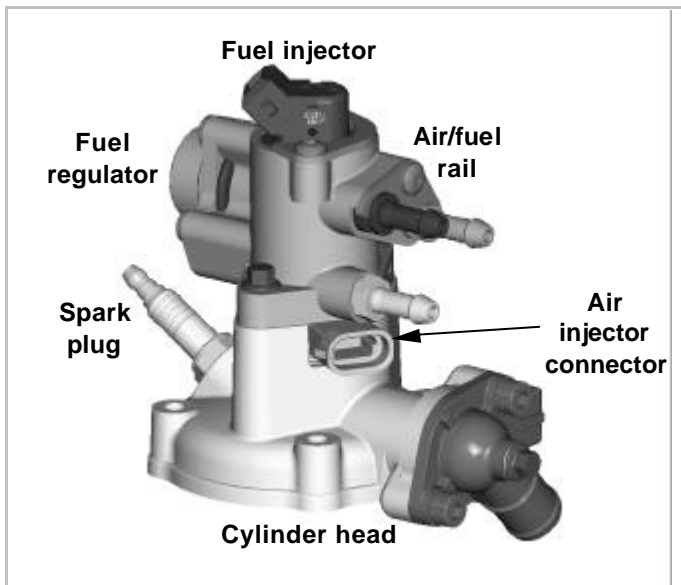

7.3 FUEL PUMP

Although the fuel pump requirements of the 2-stroke and 4-stroke systems are not identical, a low-cost, high energy-efficiency fuel pump is critical for both systems.

The fuel pump requirements of both systems differ mainly in the pressure required for injection (refer Table 8 below). This difference arises from the fact that on 'aSDI', metered fuel is delivered into the back of the air injector, which contains compressed air held at a nominal pressure of 5.0 Bar (gauge); in the case of 'SePI' the pressure downstream of the fuel injector is inlet manifold pressure (i.e. typically -0.7 to 0.0 Bar (gauge)).

Prior to designing the fuel pump described below, a thorough analysis was undertaken to determine:

- What type of pump(s) best suited the above requirements.
- What off-the-shelf fuel pump(s) were best able to meet the above requirements.

The main conclusions of this study were as follows:

- 1) The pump should be electrically rather than mechanically driven.

Two key disadvantages of mechanically-driven pumps are:

- A mechanical pump has an additional sealing requirement at the engine / fuel pump drive interface. Because leaking fuel is hazardous, both from the perspectives of flammability and load control, this seal is a 'critical' design element.
- Prime and hence start times are longer with a mechanical pump.

Table 8 – Required fuel pump performance

Attribute		Requirement	
		'aSDI' 2-stroke system	'SePI' 4-stroke system
Delivery pressure – gauge (Bar)		7.5	2.5
Delivered fuel flow (l/h)	< 7.5 kW engines	7	
	7.5 – 15 kW engines	15	
Voltage – nominal (V)		14	
Voltage – range (V)		8 – 18	
Maximum current draw (A)	< 7.5 kW engines	0.7	
	7.5 – 15 kW engines	2.0	
Mounting position		In-line OR In-tank	

housing are the only parts of this pump that see full delivery pressure.

Figure 9 - External appearance of 'Synerject' piston-style fuel pump for 'aSDI' and 'SePI'

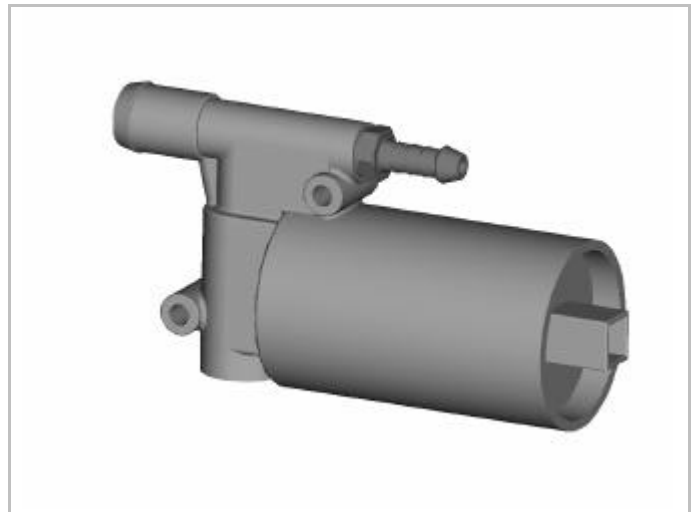

Depending upon customer preference, a cheaper, in-tank, turbine-style pump can be used to supply fuel to 'high-output' (> 7.5 kW) 'SePI' engines. However turbine-style pumps are not recommended for small / low-output 'SePI' engines, due to the relatively high current draw / low energy efficiency associated with this style of pump. Table 9 below summarises the suitability of piston-style versus turbine-style fuel pumps for various 'aSDI' and 'SePI' applications.

Table 9 – Comparison – Piston-style versus turbine-style fuel pumps

Attribute		Piston-style pump	Turbine-style pump
Lower cost			✓
Lower current draw		✓	
Suitability – 'aSDI' (2-stroke)	< 7.5 kW engines	✓	✗ *
	7.5 – 15 kW engines	✓	✗ *
Suitability – 'SePI' (4-stroke)	< 7.5 kW engines	✓	**
	7.5 – 15 kW engines	✓	✓
Mounting	In-line	✓	Not available
	In-tank	✓	✓

* Turbine pump unable to supply fuel at 7.5 Bar.

** Current draw > 1.0 A

- 2) Turbine-style pumps were found to be capable of meeting the 2.5 Bar 'SePI' fuel pressure requirement, but were unable to meet the 7.5 Bar 'aSDI' fuel pressure requirement.
- 3) A piston-style pump offers the best energy efficiency and is the preferred way of meeting the 'aSDI' 7.5 Bar fuel pressure requirement as well as the 2.5 Bar fuel pressure requirement on small / 'low-output' (< 7.5 kW) engines.
- 4) Other pump styles such as roller cell or gerotor were found to be too expensive and/or susceptible to manufacturing tolerance variations.

Figure 9 shows the external appearance of the 'in-line' version of the piston-style pump designed and developed by Synerject in response to the results of this study (an 'in-tank' version has also been designed).

This pump is a fully-sealed, self-priming electrically-driven piston-pump. The electric motor operates 'fully flooded' but is subjected to only tank (i.e. atmospheric) pressure. The pumping chamber and outlet

7.4 FUEL REGULATOR

The fuel regulator used for both 'aSDI' and 'SePI' systems is a high-volume Siemens 'Euro' automotive regulator recalibrated so as to maintain a differential pressure of 2.5 Bar under reduced (small engine) fuel flow conditions.

7.5 AIR INJECTOR ('aSDI' SYSTEM ONLY)

The air injector is a solenoid-actuated, outwardly-opening poppet valve, designed and developed specifically for the purpose of injecting precise quantities of fuel and air directly into the cylinder in the form of a finely atomised air / fuel 'cloud'. The air injector is often considered to be the 'heart' of the 'aSDI' system controlling, as it does, both the shape and timing of this 'cloud'. As mentioned previously, the fuel that passes through the air injector is both metered and delivered into the top of the air injector by a separate, PI-type automotive fuel injector.

Figure 10 - External appearance of air injector

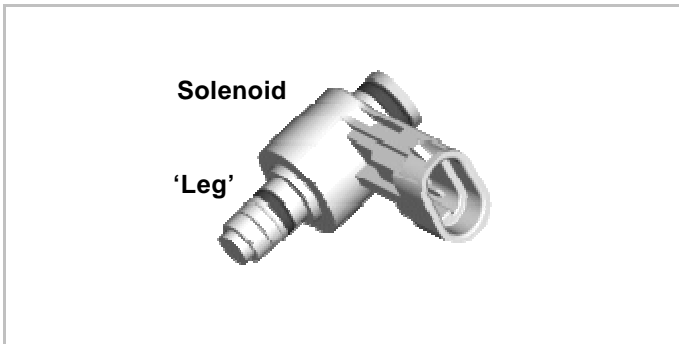

Table 10 - Key 'air injector' requirements

Attribute		Requirement
Differential pressure (Bar)		-50 to +5.0
Operating engine speed range (RPM)		0 – 12,000
Voltage – nominal (V)		14
Voltage – range (V)		8 – 18
Size (mm)	Solenoid diameter	20
	'Leg' diameter	10
	Overall Height	50 (typical) *
Mass (g)		~ 100

* Leg length can be altered to suit application

The external appearance of a typical air injector is as shown in Figure 10, and some key requirements of the air injector are listed in Table 10 above.

7.6 AIR COMPRESSOR ('aSDI' SYSTEM ONLY)

Compressed air for the 'aSDI' system is supplied by a small, 3 cm³ swept-volume, piston-compressor which is mounted to the crankcase and driven off an eccentric machined into one of the crankshaft webs (Figure 5). A cross-section of the compressor is shown on Figure 11.

Fresh, filtered air from the engine crankcase is drawn into the compressor via ports in the compressor cylinder wall. This air is then compressed and delivered to the air/fuel rail via a disc valve in the head of the compressor. Unlike a conventional piston compressor, this design requires no belt, pulley, compressor con-rod / crankshaft, inlet valve, inlet hose and/or inlet air filter. By eliminating unnecessary components in this way, this design offers an exceptionally simple, elegant and low-cost means of supplying compressed air to the air/fuel rail.

Figure 11 - 'aSDI' air compressor

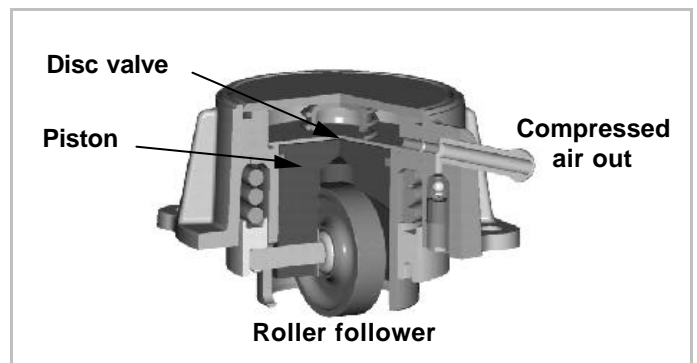

8. VEHICLE FUEL CONSUMPTION AND EMISSIONS

Before considering actual vehicle test data, a brief review of international small vehicle emissions legislation may help to put the test results subsequently presented in better context.

8.1 INTERNATIONAL EMISSIONS LEGISLATION 'FAMILIES' (DRIVECYCLES)

Although there are more than 15 small vehicle emissions standards currently in use world-wide [1], the three most widely-applied emissions legislation 'families' are those based on the ECE 40, ECE 47 and IDC drivecycles, because they apply to the largest number of small vehicles produced annually – refer Table 11. This table shows that 18.1 million motorcycles and motorscooters (approximately 90% of the total number produced annually), must be designed to pass an emissions test carried out over one of these three

drivecycles, and it is therefore results from these 'top three' drivecycles which are presented in this paper.

Table 11 – Motorcycle / motorscooter emissions legislation 'families' (drivecycles)

Country / region	Market volume (x10 ⁶)*	Drivecycle / 'family'			
		ECE 40	ECE 47	IDC	Others
China:	11.0	✓**			
India:	3.6			✓	
Europe: (> 50 cm ³ engines)	1.5	✓			
Europe: (≤ 50 cm ³ engines)	1.2		✓		
Japan:	0.9				✓
Taiwan:	0.8	✓***			
South America:	0.7				✓
USA:	0.4				✓

* Based on sales of motorcycles and motorscooters worldwide in 1999; source: *Chambre Syndicale Nationale du Motocycle (CSNM)*.

** Chinese standards are still being defined, but are expected to be similar to the European 'ECE 40' standards.

*** Although the 'warm-up' phase of the Taiwanese CNS 11386 drivecycle is different to that of the ECE 40 drivecycle, the 'bagged' portion of both drivecycles is identical, and the two tests will be treated as being equivalent for the purposes of this paper.

8.2 VEHICLE TEST RESULTS

So as to provide a broad overview of the fuel consumption and emissions performance which can be achieved with both the 'aSDI' 2-stroke and 'SePI' 4-stroke fuel systems, results from 10 test combinations involving three different vehicle models tested over the 'top three' small vehicle drivecycles will be presented as outlined in Table 12 below.

All three vehicle models tested (i.e. 'Small 2S', 'Large 2S' and 'Large 4S') were contemporary-model, high-performance, 'sports' motorscooters fitted with:

- 1-cylinder gasoline engines of specific output > 50 kW/litre.
- CVT's (Continuously Variable Transmissions) which automatically adjust engine speed relative to

roadspeed. In each case, the CVT used on the 'aSDI'- or 'SePI'-equipped vehicle was unaltered from that fitted to the baseline carburetted vehicle.

Table 12 – Vehicle test results presented - overview

Vehicle		Drivecycle		
Model	Fuel system	ECE 40	ECE 47	IDC
'Small 2S' (≤ 50 cm ³ 2-stroke)	Carburettor (baseline)		✓	
	'aSDI' ('Euro I')		✓	
	'aSDI' ('Devel.')		✓	
'Large 2S' (150-200 cm ³ 2-stroke)	Carburettor (baseline)	✓		
	'aSDI' ('Euro I')	✓		✓
	'aSDI' ('Devel.')			
'Large 4S' (150-200 cm ³ 4-stroke)	Carburettor (baseline)	✓		✓
	'SePI' ('Euro I')			
	'SePI' ('Devel.')	✓		✓

Differences between the 'Euro I'- and 'Development'-specification 'Small 2S' 'aSDI' systems tested (refer Table 12) were as follows:

- The 'development' system used a direct-injector with modified nozzle geometry.
- The geometry of the piston crown was modified on the 'development' engine for improved spray containment.
- Port timing was revised on the 'development' engine to improve scavenging.
- The 'development' ECU calibration was re-optimised to suit these hardware changes.

The fuel consumption and emissions results from all tests, along with relevant current and future emissions limits, are presented on a drivecycle basis in Table 13 to Table 15 below. In each case:

Table 13 – Tailpipe emissions (uncatalysed) and fuel consumption – ECE 40 drivecycle

Vehicle		Tailpipe emissions – measured				Fuel consumption – measured			
Model	Fuel system	HC (g/km)	CO (g/km)	NOx (g/km)	HC+NOx (g/km)	(g/km)		(l/100km)	(km/l)
						Absolute	Relative		
'Large 2S' (150-200 cm ³ 2-stroke)	Carburettor (baseline):	8.5	10.9	0.04	8.5	33.4	-	4.43	22.6
	'aSDI' (Euro I system):	1.06	1.47	0.09	1.16	19.6	-41%	2.58	38.7
		1.76 *	1.82 *	0.06 *	1.82 *	20.4 *	-39% *	2.70 *	37.0 *
'Large 4S' (150-200 cm ³ 4-stroke)	Carburettor (baseline):	0.85	11.1	0.17	1.02	24.6	-	3.33	30.0
	'SePI' (Devel. system):	0.50	1.34	0.25	0.72	20.5	-17%	2.79	35.9

Vehicle type approval		Tailpipe emissions limits				
Category (Region)	Year	HC (g/km)	CO (g/km)	NOx (g/km)	HC+NOx (g/km)	
Motor-cycle (Taiwan)	1998:	-	< 3.5	-	< 2.0	
	2003**:	2S	-	< 7.0 **	-	< 1.0 **
		4S	-	< 7.0 **	-	< 2.0 **
> 50 cm ³ 2-wheeler (Europe)	1999: (Euro I)	2S	< 4.0	< 8.0	< 0.1	(< 4.1)
		4S	< 3.0	< 13.0	< 0.3	(< 3.3)
	2003: (Euro II) ***		< 1.2 ***	< 5.5 ***	< 0.3 ***	(< 1.5) ***

* Re-calibrated for improved compliance with 'Euro I' 0.1 g/km NOx limit for 2-stroke vehicles.

** Cold-start emissions limits – cannot be directly compared to hot-start results presented.

*** Expected limits only – refer [3].

- All tests were carried out at 'stabilised' low mileage (typically around 500 km).
- Engine-out emissions are quoted in all cases (i.e. no exhaust after-treatment catalysts were fitted).
- Each result quoted has been averaged from 2- or 3-off repeat tests.

Important conclusions, drawn from the data presented in Table 13 to Table 15, are as follows:

- 1) For each vehicle/drivecycle combination tested, it was possible to meet current emissions limits in Europe, India and Taiwan, without requiring exhaust after-treatment.
- 2) The 'Large 2S' and 'Large 4S' engines were also able to meet future emissions standards in Europe and India without requiring exhaust after-treatment.

- 3) The 'Development' version of the 'Small 2S' engine was able to meet future European emissions standards without requiring exhaust after-treatment.
- 4) Relative to the baseline carburetted 2-stroke engines, the 'aSDI' engines demonstrated a fuel consumption saving of up to 50%.
- 5) Relative to the baseline carburetted 4-stroke engine, the 'SePI' engine demonstrated a fuel consumption saving of up to 20%.

8.3 EXPECTED FUTURE TRENDS IN INTERNATIONAL EMISSIONS LEGISLATION

Aside from on-going reductions in drivecycle emissions limits (as reflected by the current and expected emissions limits presented in Table 13 to Table 15), other anticipated trends in international small vehicle emissions legislation are as follows:

Table 14 – Tailpipe emissions (uncatalysed) and fuel consumption – ECE 47 drivecycle

Vehicle		Tailpipe emissions – measured				Fuel consumption – measured			
Model	Fuel system	HC (g/km)	CO (g/km)	NOx (g/km)	HC+NOx (g/km)	(g/km)		(l/100km)	(km/l)
						Absolute	Relative		
'Small 2S' (£ 50 cm ³ 2-stroke)	Carburettor (baseline):	7.2	19.1	0.1	7.3	25.8	-	3.46	28.9
	'aSDI' (Euro I system):	1.80	2.47	0.25	2.06	14.9	-42%	1.97	50.8
	'aSDI' (Devel. system):	0.48	0.75	0.45	0.92	11.8	-54%	1.55	64.7

Vehicle type approval		Tailpipe emissions limits			
Category (Region)	Year	HC (g/km)	CO (g/km)	NOx (g/km)	HC+NOx (g/km)
£ 50 cm ³ 2-wheeler (Europe)	1999: (Euro I)	-	< 6.0	-	< 3.0
	2002: (Euro II)	-	< 1.0	-	< 1.2

Table 15 – Tailpipe emissions (uncatalysed) and fuel consumption – IDC drivecycle

Vehicle		Tailpipe emissions – measured				Fuel consumption – measured			
Model	Fuel system	HC (g/km)	CO (g/km)	NOx (g/km)	HC+NOx (g/km)	(g/km)		(l/100km)	(km/l)
						Absolute	Relative		
'Large 2S' (150-200 cm ³ 2-stroke)	'aSDI' (Euro I system):	1.09	1.22	0.08	1.17	17.9	(N/A) *	2.37	42.2
'Large 4S' (150-200 cm ³ 4-stroke)	Carburettor (baseline):	0.90	9.59	0.10	1.00	22.9	-	3.13	32.0
	'SePI' (Devel. system):	0.56	1.21	0.22	0.78	18.3	-20%	2.50	40.0

Vehicle type approval		Tailpipe emissions limits			
Category (Region)	Year	HC (g/km)	CO (g/km)	NOx (g/km)	HC+NOx (g/km)
2-wheeler (India)	2000: [COPA] **	-	< 2.0 [+20%] **	-	< 2.0 [+20%] **
	2003 ***:	-	< 1.5 ***	-	< 1.5 ***
	2005 ***:	-	< 1.0 ***	-	< 1.0 ***

* Baseline carburettor vehicle not tested over IDC (anticipated fuel consumption benefit @ 40%).

** [COPA] = 'Conformity of Production Allowance' (relative to 'Type Approval' emissions limit); no COPA after 2003.

*** Expected limits only – Future Indian emissions limits have not yet been finalised.

1) Increased specification of 'cold-start' emissions testing:

In the USA, motorcycles are currently tested using the same (FTP 75) 'cold-start' drivecycle as passenger cars [1], and Taiwan plans to introduce a 'cold-start' version of the (ECE 40-based) CNS 11386 drivecycle in 2003 [16]. In Europe, research is currently underway aimed at developing a new, more representative, small vehicle emissions test drivecycle by 2002 which may also be of the 'cold-start' type and which will be used for certification from 2006 onwards [3].

2) New / more stringent emissions durability requirements:

In Taiwan and Thailand, it is already the case that small vehicles must meet specified emissions limits at 15,000 and 12,000 km respectively; it is anticipated that similar requirements will soon be introduced into Europe, India and China.

3) Increased implementation of evaporative emissions requirements:

California has had an evaporative emissions requirement for motorcycles since 1978 [17], and Taiwan since 1988 [4]; motorcycles of greater than 150 cm³ swept volume which are sold into the Thai market must also meet an evaporative emissions requirement from 2001 onwards [18], and similar legislation in other countries / regions may be introduced in the near-to-medium term.

Synerject's 'aSDI' and 'SePI' small vehicle fuel injection systems are well placed to meet these anticipated developments by virtue of the following features:

1) Large reductions in engine-out emissions.

(As demonstrated by Table 13 to Table 15).

2) Reduced unit-to-unit performance variation.

Although unit-to-unit exhaust emissions scatter is affected by many factors other than the fuel system (e.g. engine compression ratio; squish; inlet / exhaust timing; etc.), based on accumulated experience in the automobile industry, it is well known that fuel-injected vehicles typically exhibit less unit-to-unit emissions variation than carburetted vehicles, particularly when an oxidising catalyst is used to control exhaust emissions [19].

3) Proven emissions durability.

Figure 12 and Figure 13 show the results from a 15,000 km emissions durability test on a 'Small 2S',

'aSDI'-equipped, Euro I vehicle. As can be seen from these figures, the emissions performance remained stable. This correlates well with the high level of emissions durability previously demonstrated on other versions of the OCP air-assisted DI system [14] [20].

Figure 12 – HC+NOx emissions durability – 'Small 2S' Euro I vehicle

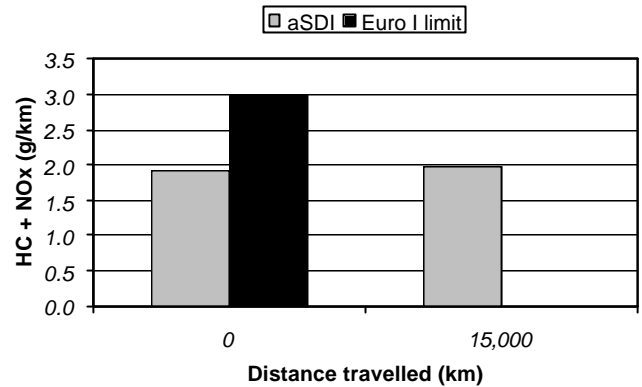
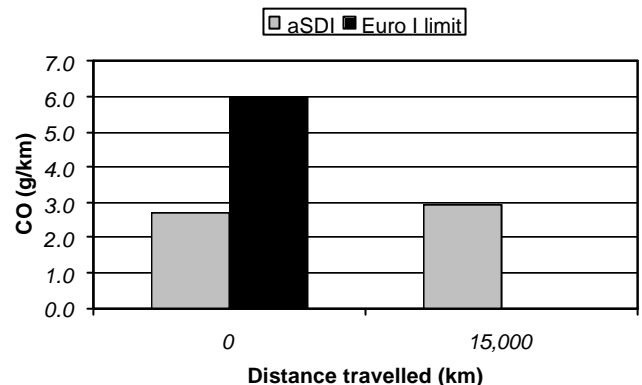

Figure 13 – CO emissions durability – 'Small 2S' Euro I vehicle



4) (Optional) electronically-controlled CVP valve:

A CVP (Canister Vapour Purge) valve has been allowed for in the ECU design. Currently, a simple and cheap 'On/Off' driver is considered sufficient for this purpose; this can be upgraded to a PWM (Pulse Width Modulated) driver if more stringent requirements in this area are introduced.

5) (Optional) catalyst fitment:

Both 'aSDI' and 'SePI' systems can be combined with an exhaust after-treatment catalyst if required, thereby further reducing tailpipe HC and CO by 50% or more.

9. VEHICLE DRIVEABILITY

Relative to carburetted fuel systems, both 'aSDI' and 'SePI' systems offer significantly improved vehicle driveability as a result of the following engine performance benefits:

- 1) Better combustion stability and better vehicle-to-vehicle performance repeatability, due to precise control of A/F, ignition and injection timing.
- 2) Fast, reliable cold start. Both systems are capable of good, repeatable starts at all ambient temperatures in the range: -10°C to 40°C. Otherwise-equivalent carburetted vehicles have longer and/or less repeatable crank-to-run times (particularly when the ambient temperature is below 10°C), and may subsequently stall or 'race'.
- 3) Automatic optimisation of all parameters as engine warms up. The ECU compensates for engine temperature differences automatically, and engine response is not affected. Manual 'choke' actuation is not required.
- 4) Automatic compensation for changes in air inlet pressure due to altitude and/or partial inlet air filter blockage (with optional ambient air pressure sensor).

Because of its good combustion stability and (optional) electronic oiling system, 'aSDI' also reduces the amount of visible smoke and odour emitted by 2-stroke engines down to near-imperceptible levels.

As a result of the above benefits, significantly improved vehicle driving behaviour is perceived by the average operator.

Using the driveability rating system specified in Table 16 for example, the results from back-to-back driveability tests carried out with carburetted and fuel-injected 'Small 2S' and 'Large 4S' vehicles are as shown in Table 17 and Table 18 below.

Based on these results, it can be seen that the average operator is likely to perceive a clear driveability benefit when 'SePI' is fitted (i.e. relative to an otherwise equivalent baseline carburetted engine), and that this driveability difference is even greater in the case of 'aSDI'.

Table 16 - Vehicle driveability rating system

Rating *	Description
10	Exceptional (No undesirable elements)
9	No deficiencies (Traces of undesirable elements)
8	No significant deficiencies (Deficiencies only under special operating conditions)
7	Minor deficiencies (One or more hard-to-detect deficiencies)
6	Obvious, but not objectionable, problems (One or more noticeable deficiencies)
5	Marginal (One or more obvious deficiencies – customer complaint likely)
4	Disturbing (One or more obvious deficiencies – customer seeks corrective action)
3	Lack of confidence (One or more obvious deficiencies – customer loses confidence in the ability of the vehicle to perform reliably)
2	Unreliable (Vehicle function is unreliable)
1	Unpredictable (Vehicle function is unpredictable)

* A driveability rating difference of more than 0.5 represents a significant difference, as perceived by the average operator

Note that the only area in which the 'aSDI' and 'SePI' vehicles were not judged to be superior than the baseline carburetted vehicles was in terms of roll-on throttle response (refer Table 17 and Table 18). In this category, the good response of the baseline carburetted vehicles is a reflection of rich jetting, commonly used on small vehicles to avoid 'hesitation' during transient throttle operation. The 'aSDI' and 'SePI' vehicles were also calibrated to accelerate without hesitation, however unlike the baseline carburetted vehicles, excess fuel has also been eliminated wherever possible in the interests of optimum fuel consumption and reduced engine-out exhaust emissions. This driveability difference therefore reflects the greater flexibility available when trading off exhaust emissions against throttle response with 'aSDI' and/or 'SePI', rather than a response limitation of the 'aSDI' and/or 'SePI' systems per se.

**Table 17 - Vehicle driveability test results –
‘Small 2S’ (£ 50 cm³ 2-stroke vehicle)**

Test	Carburetted vehicle	‘aSDI’ vehicle
Cold start:	5.0	7.0
Hot start:	7.0	7.0
Warm-up:	6.5	7.5
Idle:	5.5	7.0
Roll-on throttle response:	7.5	7.0
Low-speed cruise: (10 km/h)	5.5	8.0
High-speed cruise: (40 km/h)	7.5	7.5
Maximum acceleration:	7.5	7.5
Overrun:	5.0	8.0
Average rating:	6.33	7.39

**Table 18 - Vehicle driveability test results –
‘Large 4S’ (150 – 200 cm³ 4-stroke vehicle)**

Test	Carburetted vehicle	‘SePI’ vehicle
Cold start:	5.5	7.0
Hot start:	7.0	7.5
Warm-up:	6.5	7.5
Idle:	7.0	7.5
Roll-on throttle response:	7.5	7.0
Low-speed cruise: (10 km/h)	7.0	8.0
High-speed cruise: (60 km/h)	7.5	7.5
Maximum acceleration:	7.5	7.5
Overrun:	7.0	8.0
Average rating:	6.95	7.50

10. DIAGNOSTICS AND SERVICING

To make the servicing of ‘aSDI’ and ‘SePI’ vehicles as fast and simple as possible, all ECU’s come complete with a comprehensive, on-board, diagnostic software package. The aims of this software package are to:

- Provide service personnel with easy access to necessary information.
- Provide service personnel with a simple means of carrying out common tests as required for the purpose of problem diagnosis and/or regular servicing.
- Help make the transition from carburetted to ‘aSDI’- and/or ‘SePI’-equipped vehicles as smooth and easy

as possible.

Depending on customer preference, two different means are available for accessing this information as follows:

- 1) Diagnostic/service information can be displayed via MIL (Malfunction Indication Lamp) flashing codes.
- 2) Diagnostic/service information can be displayed by means of a suitable tool which communicates with the ECU using the ‘Keyword 2000’ communications protocol.

To facilitate option 2) above in cases where the customer does not have an existing tool, Orbital Engine Co. has developed a low-cost, hand-held diagnostic/service tool known as ‘Pocket Dash’.

Key features of ‘Pocket Dash’ are as follows:

- 1) Small, hand-held, low-cost electronic display.
- 2) Easy-to-understand, graphic display format.
- 3) Display text available in various languages to suit different geographical markets.
- 4) Ability to display various operating parameters such as engine RPM, ignition angle, injection angle, etc. for servicing purposes.
- 5) Ability to undertake tests commonly required for diagnostic purposes; e.g. operate temperature gauge or MIL (Malfunction Indication Lamp); generate spark at spark plug; etc.
- 6) Ability to display any faults which are stored within the ECU.
- 7) Ability to adjust a limited number of factory presets (e.g. ‘SePI’ idle A/F) within a ‘safe’ range for the purpose of continued vehicle compliance with local emissions standards. (This feature eliminates the need to fit a ‘CO potentiometer’ to the vehicle).
- 8) Ability to download software upgrades (if required).

11. FUTURE DEVELOPMENTS

The main aim of this paper so far has been to describe the current status of Synerject’s ‘aSDI’ 2-stroke and ‘SePI’ 4-stroke small vehicle systems. Looking forward, planned future developments are as follows:

- 1) On-going work to ensure compliance with future emissions standards.

- 2) Piece cost reductions through improved economies of scale.
- 3) Piece cost reductions through localisation.
- 4) System cost reductions through improved integration of the 'aSDI' and 'SePI' systems into the base engine design.

Under category 2), our intent is to broaden the range of application of 'aSDI' and 'SePI' to include not just gasoline-powered small vehicles, but also:

- Other small engines such as small outboard engines and those used on electrical generators and heavy-duty gardening equipment.
- Alternative fuels such as CNG (Compressed Natural Gas) and LPG (Liquid Petroleum Gas).

CONCLUSIONS

The main conclusions arising from the information presented in this paper are as follows:

- 1) Significant reductions in small vehicle fuel consumption and emissions are available, through application of the recently introduced DI 'aSDI' system to 2-stroke engines, and PI 'SePI' system to 4-stroke engines.
- 2) By applying these systems to contemporary-market 2- and 4-stroke vehicles, current emissions limits were met in Europe, India and Taiwan, without requiring exhaust after-treatment. In most cases, future emissions limits were also met, again without requiring exhaust after-treatment.
- 3) Relative to otherwise-equivalent carburetted 2-stroke engines, 'aSDI' demonstrated a fuel consumption saving of around 40% while simultaneously meeting current emissions limits.
- 4) Relative to otherwise-equivalent carburetted 4-stroke engines, 'SePI' demonstrated a fuel consumption saving of around 20% while simultaneously meeting current emissions limits.
- 5) Relative to otherwise-equivalent carburetted vehicles, 'aSDI'- and 'SePI' -equipped vehicles exhibit significantly improved driveability.
- 6) While high-volume, low-cost automotive components are used wherever possible, 'aSDI' and 'SePI' are more than simple 'adaptations' of passenger-car fuel systems. Rather, both systems have been carefully designed 'from the ground up' and developed to meet the cost and performance requirements of small vehicles world-wide. In some cases (e.g. ECU and

fuel pump), new system-specific components have been developed for this purpose.

- 7) Through careful analysis and understanding of future trends in small vehicle markets world-wide (in particular: trends in international exhaust emissions standards), both 'aSDI' and 'SePI' have been designed and developed to be 'future proof'.

By combining low cost and high performance in this way, we at Synerject believe that our 'aSDI' and 'SePI' systems truly offer an optimum 'emissions solution' for small, gasoline-fuelled vehicles world-wide, irrespective of whether a 2-stroke or 4-stroke base engine is preferred.

DEFINITIONS, ACRONYMS, ABBREVIATIONS

Below is a short description of acronyms, abbreviations and other words with special definitions which have been used in this paper.

Word / Abbreviation	Meaning
A/F	Air / Fuel Ratio
'aSDI'	air-assisted Synerject Direct Injection
'Bagged' (phase of drivecycle)	Phase of drivecycle during which exhaust emissions sampling is carried out.
CNS	Chinese National Standard
CO	Carbon monOxide
'Cold start' (emissions test)	Vehicle emissions test which requires that vehicle is started 'cold' and that exhaust emissions sampling commences simultaneously with engine starting.
COP(A)	Conformity of Production (Allowance)
CO Potentiometer	A potentiometer which can be used by service personnel to adjust idle A/F for the purpose of ensuring continued compliance with legislated CO limits.
CVP	Canister Vapour Purge
CVT	Continuously Variable Transmission
Development / Devel. (system)	Development phase (system)
DI	Direct Injection
ECU	Engine Control Unit
EFI	Electronic Fuel Injection
EGR	Exhaust Gas Recirculation
ETB	Electronic Throttle Body
HC	unburnt HydroCarbons

Word / Abbreviation	Meaning
HEI (ignition system)	High Energy Inductive (ignition system)
IAV	Idle Air Valve
(catalyst) 'Light-off'	Temperature at which the chemical conversion efficiency of an exhaust catalyst rises above 50%.
MIL	Malfunction Indication Lamp
N/A	Not Available
NOx	Nitrogen Oxides
OCP	Orbital Combustion Process
PI	Port Injection
SAI	Secondary Air Injection
'SePI'	Synerject electronic Port Injection
'Small vehicles'	auto-rickshaws, motorcycles, motorscooters, etc.
TA T-AP (sensor)	Type Approval Temperature - Absolute Pressure (sensor)
TPS	Throttle Position Sensor
TWC	Three-Way Catalyst (i.e. oxidises HC / CO & reduces NOx simultaneously)
'Warm-up' (drivecycle phase)	Phase of drivecycle which is used to warm the engine up to normal operating temperature prior to commencement of exhaust emissions sampling.

REFERENCES

- [1] CONCAWE, "Motor Vehicle Emission Regulations and Fuel Specifications – Part 2 – Detailed Information and Historic Review (1970 – 1999)", 2000.
- [2] Norbye J., "Automotive Fuel Injection Systems – A Technical Guide", ISBN 0 85429 347 7, 1985.
- [3] Commission of the European Communities, "Proposal for a Directive of the European Parliament and of the Council Amending Directive 97/24/EC on Certain Components and Characteristics of Two or Three-Wheeled Motor Vehicles", 2000/0136 (COD), 2000.
- [4] Environmental Protection Administration (EPA) of the Government of the Republic of China, "Current Situation of Motorcycles Pollution Control in Republic of China", 1996.
- [5] Aprilia S.P.A., "DITECH, Direct Injection Technology", Press release, May 2000.
- [6] ACEM Pollution working group, "The motorcycle industry in Europe, ACEM Pollution Research Program on Motorcycles", 1998.
- [7] Nuti M., "Emissions from Two-Stroke Engines", ISBN 0-7680-0215-X, 1998.
- [8] McDowell A. et al, "Catalyst Deactivation on a Two-Stroke Engine", SAE paper 982015.
- [9] Caponi D. and Nuti M., "Appraisal of Secondary Air Injection for Emission Reduction in Small 2T SI Engines", SAE paper 2000-01-0899.
- [10] Conference proceedings: "21. Internationales Wiener Motorensymposium, 4.-5. Mai 2000 (21st International Vienna Engine Symposium, 4.-5. May 2000)", ISBN 3-18-342012-0, 2000.
- [11] Houston R. and Cathcart G., "Combustion and Emissions Characteristics of Orbital's Combustion Process Applied to Multi-Cylinder Automotive Direct Injected 4-Stroke Engines", SAE paper 980153.
- [12] Eichlseder E. et al, "Chancen und Risiken von Ottomotoren mit Direkteinspritzung (Potential and Risks of Gasoline Direct Injection Engines for Future Passenger Car Drivelines)", MTZ 61, No. 3, 2000.
- [13] Worth D. et al, "Design Considerations for the Application of Air-Assisted Direct In-Cylinder Injection Systems", SAE paper 972074.
- [14] Shawcross D. et al, "A Five-Million Kilometre, 100-Vehicle Fleet Trial, of an Air-Assist Direct Fuel Injected, Automotive 2-Stroke Engine", SAE paper 2000-01-0898.
- [15] Bell G. and Finucci C., "Exhaust Emissions Sensitivities with Direct Injection on a 50cc Scooter", SAE paper 970365.
- [16] Communication with Environmental Protection Administration (EPA) of the Government of the Republic of China, 1998.
- [17] State of California Air Resources Board (CARB), "Hearing Notice and Staff Report – Proposed Amendments to the California On-Road Motorcycle Regulation", 1998.
- [18] Walsh M., "Motor Vehicle Standards and Regulations around the World", mpwalsh@igc.apc.org, 1999.

- [19] Klingenberg H., et al, "Exhaust Emission Compliance and Testing Procedures based on Averaging", Second Symposium on Indian Automotive Technology (SIAT), Volume 1, 1987.
- [20] Houston R. et al, "Development of a Durable Emissions Control System for an Automotive Two-Stroke Engine", SAE paper 960361.

CONTACT DETAILS

Greg Bell
Synerject Systems Integration
1 Whipple Street
Balcatta, 6021
AUSTRALIA

Telephone: + 61 (0)8 9441 2311
Facsimile: + 61 (0)8 9441 2309
Email: gbell@orbeng.com.au