

September 1, 2020

**Advice 4303-G/5936-E**

(Pacific Gas and Electric Company ID U 39 M)

Public Utilities Commission of the State of California

**Subject: PG&E's 2021 Energy Efficiency Annual Budget Advice Letter in Compliance with Decisions 15-10-028 and 18-05-041**

**I. Purpose**

Pacific Gas and Electric Company (PG&E) submits its 2021 energy efficiency (EE) portfolio budget (2021 EE Budget) by Tier 2 advice letter in compliance with the *Decision Re Energy Efficiency Goals for 2016 and Beyond and Energy Efficiency Rolling Portfolio Mechanics*, the "Rolling Portfolio Decision" (Decision (D.) 15-10-028),<sup>1</sup> the *Decision Addressing Energy Efficiency Business Plans* (D.18-05-041),<sup>2</sup> and guidance from the California Public Utilities Commission (CPUC or Commission) Energy Division (ED) staff (Staff).

PG&E requests that the Commission approve its 2021 Annual Budget Advice Letter (ABAL) spending budget of \$237,724,275 and its 2021 cost recovery budget of \$227,724,275 through a non-standard disposition effective January 1, 2021.<sup>3</sup> PG&E additionally requests that the Commission approve the forecasted 2021 electric/gas split for cost recovery allocations effective January 1, 2021.<sup>4</sup>

**II. Background****A. Regulatory Requirements**

D.15-10-028 requires each EE program administrator (PA) to submit an advice letter with a budget for the next calendar year's EE portfolio by the first business day of September

---

<sup>1</sup> D.15-10-028, Ordering Paragraph (OP) 4.

<sup>2</sup> D.18-05-041, OP 41-47.

<sup>3</sup> Section III.J. of this advice letter provides more detail on PG&E's cost recovery request.

<sup>4</sup> The 2021 ABAL forecasted electric/gas split is 83%/17%, applicable to the non-fuel-substitution portion of its EE portfolio budget as shown in Section III.J.1, Table 15.

each year.<sup>5</sup> D.18-05-041 subsequently adopted the budgets set forth in the Business Plans for 2018-2025, which serve to “[set] budget expectations to be more fully developed in annual budget filings.”<sup>6</sup>

## **B. Submittal Requirements**

D.15-10-028 requires each program administrator’s (PA) advice letter to contain:

- A portfolio cost-effectiveness statement; and
- Application summary tables with forecast budgets and savings by sector and program/intervention.<sup>7</sup>

D.18-05-041 requires that the investor-owned utilities’ (IOUs) ABALs include the following:

- A forecasted Total Resource Cost (TRC) test score that meets or exceeds 1.25, except during program years 2019-2022, when the forecasted TRC must meet or exceed 1.0;
- Forecasted energy savings goals that must meet or exceed Commission-established savings goals for each IOU; and
- A forecasted budget that must not exceed the PA’s annual budget in the approved Business Plans, or (if applicable) the revised annual budget in this ABAL.<sup>8</sup>

If a Program Administrator’s (PA) ABAL submitted for program year 2019 through program year 2022 fails to meet the criteria above, including a forecasted portfolio TRC of 1.0 during program years 2019-2022, the PA is to hold a workshop to provide transparency into the associated challenges and receive feedback that would potentially aid the PA in revising its Business Plan pursuant to D.15-10-028 for Commission approval.<sup>9</sup>

## **C. Contents of this Submittal**

PG&E’s advice letter is organized as follows:

- Budget, Goals, and Cost-Effectiveness
- Business Plan Revision
- 2021 Forecast Approach

---

<sup>5</sup> D.15-10-028, OP 4.

<sup>6</sup> D.15-10-028, p.43.

<sup>7</sup> Ibid, p. 59.

<sup>8</sup> D.18-05-041, p. 133.

<sup>9</sup> D.18-05-041, pp. 134-135.

- COVID Considerations
- Cost-Effectiveness Challenges
- Portfolio Strategies to Improve Cost-Effectiveness in 2021
- 2021 Program Changes
- Evaluation, Measurement & Verification (EM&V)
- Unspent Funds
- Cost Recovery
- Metrics

In addition to the information above, PG&E's 2021 ABAL includes the following attachments:

- Attachment 1 – California Energy Data and Reporting System (CEDARS) Filing Confirmation
- Attachment 2 – Program Changes Table
- Attachment 3 – Supplemental Budget Tables
- Attachment 4 – Appendices<sup>10</sup>

### **III. Discussion**

#### **A. Budget, Goals, and Cost-Effectiveness**

PG&E proposes a 2021 EE portfolio budget of \$237.7 million. Table 1 provides an overview of PG&E's 2021 forecasted portfolio budget, savings, and cost-effectiveness. The net savings, TRC, Program Administrator Cost (PAC), and Ratepayer Impact (RIM) forecast values exclude market effects. PG&E is forecasting a portfolio that meets the new 2021 savings goals but is not forecasted to be cost-effective in 2021 as the result of a myriad of factors, including but not limited to PG&E's continued portfolio transition in 2021 to an outsourced model, the result of which is the continued ramp-down of existing programs and the ramp-up of new third-party local and statewide programs.<sup>11</sup> PG&E expects its portfolio cost-effectiveness to improve when most existing programs have transitioned out of the portfolio and most new programs are fully ramped up. In addition to the portfolio transition impact on cost-effectiveness, PG&E still faces cost-effectiveness challenges discussed in detail in Section III.E. PG&E is taking steps to address these challenges and improve cost-effectiveness in 2021, as discussed in Section III.F.

---

<sup>10</sup> Appendix tables include, but are not limited to, the Statewide Program Budgets table and the Caps and Targets table.

<sup>11</sup> See Section III.C. for details on PG&E's forecasting approach.

**Table 1: PG&E 2021 Forecast Budget and Savings Summary**

Sector	Program Year (PY) Budget	PG&E PY FORECAST ENERGY SAVINGS (Net)		
		kWh	kW	MM-therms
Residential	\$49,928,667	178,135,896	44,668	6.8
Commercial	\$56,625,743	90,210,572	12,868	3.7
Industrial	\$28,941,375	47,017,763	4,031	3.4
Agricultural	\$13,871,803	17,782,872	3,962	0.1
Emerging Tech	\$6,320,066	0	0	0.0
Public	\$16,132,136	14,775,962	1,701	0.2
WE&T	\$8,943,045	0	0	0.0
Finance	\$5,198,652	46,651,867	7,931	0.1
OBF Loan Pool	\$17,000,000	0	0	0.0
<b>PG&amp;E Total Program Savings (w/out C&amp;S)</b>	<b>\$202,961,487</b>	<b>394,574,933</b>	<b>75,161</b>	<b>14.3</b>
	<b>CPUC Program Savings Goal</b>	<b>358,000,000</b>	<b>73,000</b>	<b>14.0</b>
	<b>Forecast savings as % of CPUC Program Savings Goal</b>	<b>110%</b>	<b>103%</b>	<b>102%</b>
Codes and Standards	\$25,253,817	976,402,091	212,619	14.5
<b>PG&amp;E EM&amp;V</b>	<b>\$9,508,971</b>			
<b>PG&amp;E PY Spending Budget Request <sup>(a)</sup></b>	<b>\$237,724,275</b>			
<b>(LESS) PG&amp;E Estimated Uncommitted and Unspent Carryover Balance <sup>(b)</sup></b>	<b>\$10,000,000</b>			
<b>PG&amp;E PY Budget Recovery Request <sup>(c)</sup></b>	<b>\$227,724,275</b>			
<b>PG&amp;E Authorized PY Budget Cap (D.18-05-041) <sup>(d)</sup></b>	<b>\$374,399,466</b>			
<b>MCE PY Budget Recovery Request (excl. CCA Uncommitted/Unspent Carryover) <sup>(e)</sup></b>	<b>\$3,149,880</b>			
<b>RCEA PY Budget Recovery Request (excl. CCA Uncommitted/Unspent Carryover) <sup>(f)</sup></b>	<b>\$0</b>			
<b>BayREN PY Budget Recovery Request (excl. CCA Uncommitted/Unspent Carryover) <sup>(e)</sup></b>	<b>\$16,610,596</b>			
<b>3C-REN PY Budget Recovery Request (excl. CCA Uncommitted/Unspent Carryover) <sup>(e)</sup></b>	<b>\$2,997,903</b>			
<b>Total PA (IOU+CCAs+RENS) Recovery Budget</b>	<b>\$250,482,654</b>			
<b>PG&amp;E Forecast PY TRC <sup>(g)</sup></b>	<b>0.89</b>			
<b>PG&amp;E Forecast PY PAC <sup>(g)</sup></b>	<b>1.23</b>			
<b>PG&amp;E Forecast PY RIM <sup>(g)</sup></b>	<b>0.54</b>			

(a) This is the amount by which Statewide 25% requirement will be measured and what PG&E intends to spend in the program year, including carryovers.

(b) The estimated balance of all unspent and uncommitted reflects the total unspent uncommitted for all prior program years up to and through December 31, 2020. These funds are an estimate at the time of this Advice Letter filing and not yet final.

(c) The amount of funds to be collected (budget recovery) for PY 2021.

(d) The IOU Authorized PY Budget Cap uses the "Total Program" budget from PG&E's approved Business Plan Table 1.5. This total 2020 business plan budget was unchanged in the budget true-up table presented in PG&E's 2019 ABAL, Second Supplemental Advice 4011-G-B/5375-E-B filed on January 23, 2019 and approved by the CPUC on April 2, 2019.

(e) Marin Clean Energy (MCE), Bay Area Regional Energy Network (BayREN), and Tri-County Regional Energy Network (3C-REN) 2021 budget recovery requests based on draft 2021 ABAL budgets as presented to the California Energy Efficiency Coordinating Committee (CAEECC) on August 5, 2020, including carryover and 4% EM&V inclusive of CPUC EM&V. These amounts are subject to change upon MCE, BayREN, and 3C-REN 2021 ABAL submissions.

(f) No 2021 cost recovery for the Redwood Cost Energy Authority (RCEA) is required at this time because PG&E transferred funds from its 2020 budget to RCEA for RCEA's full 3-year program amount, including program year 2021, as approved and directed by Resolution E-5050. Thus, RCEA's 2021 budget recovery request is set at \$0.

(g) The portfolio TRC, PAC, and RIM presented in this table are lower than the TRC, PAC, and RIM including codes and standards and market effects.

Table 2 provides the TRC test and PAC test forecasts for its 2021 EE portfolio, both with and without the Codes and Standards program benefits. The TRC and PAC estimates exclude market effects.

**Table 2: PG&E 2021<sup>(a)</sup> Cost-Effectiveness Statement**

Cost-Effectiveness Scenario	2021 TRC Forecast	2021 PAC Forecast	2021 RIM Forecast
Portfolio without C&S	0.89	1.23	0.54
Portfolio with C&S	1.91	6.38	0.66

(a) The 2021 CET User Interface from CEDARS was used to calculate cost-effectiveness.

TRC, PAC, and RIM calculations in Table 2 include costs for:

- Resource and non-resource programs, including Financing and Workforce Education and Training (WE&T) programs;
- EM&V;<sup>12</sup>
- An estimated \$15.6 million for PG&E's ESPI award in 2021;<sup>13</sup>
- Statewide (SW) Marketing, Education and Outreach (ME&O) costs;<sup>14</sup> and
- On-Bill-Financing (OBF) cost of capital.<sup>15</sup>

TRC, PAC, and RIM calculations in Table 2 exclude costs for:

- Emerging Technologies (ET) program costs;
- BayREN, 3C-REN, RCEA, and MCE benefits and costs;<sup>16</sup>
- Financing costs including credit enhancements approved for the Statewide Financing Pilots in D.13-09-044;
- Administrative costs associated with PG&E's performance of the fiscal agent role for BayREN and 3C-REN;<sup>17</sup>
- Energy Savings Assistance (ESA) benefits and costs; and
- Market effects.

### **CEDARS Discrepancies**

The total PG&E portfolio budget, TRC, and PAC values presented in this advice letter contain some discrepancies with the values shown in the CEDARS dashboard for this 2021 filing. These discrepancies are discussed in the sections below and summarized in the Tables 3 and 4 below.

<sup>12</sup> EM&V costs total 4% of PG&E's EE portfolio budget. See Section III.H. for more details on EM&V.

<sup>13</sup> PG&E's \$15.6 million ESPI award estimate for 2021 is based on the ESPI reward request to be submitted via advice letter on September 1, 2020.

<sup>14</sup> PG&E is including SW ME&O costs in its TRC calculation per direction on forecasted TRC costs in the EE Policy Manual V6.0 p.26 and D.09-09-047 pp.69-70, 288.

<sup>15</sup> See "OBF Cost of Capital" discussion under this Section III.A.

<sup>16</sup> D.12-11-015.

<sup>17</sup> D.19-12-021, OP 5

### *OBF Loan Pool Budget*

PG&E's 2021 OBF loan pool contribution budget of \$17,000,000 is included in PG&E's advice letter total portfolio budget but excluded from total portfolio budget shown in the CEDARS dashboard for the 2021 filing. This is because the OBF loan pool Program ID is flagged in CEDARS for exclusion from the portfolio budget as these funds are not forecasted expenditures; rather, they are funds contributing to PG&E's revolving loan pool that is not captured in portfolio budget through CEDARS expenditures reporting.

### *PG&E Administrative Support for RENs*

PG&E administrative support for RENs comprises a cost that is excluded in PG&E's advice letter TRC and PAC but included from the TRC and PAC on the CEDARS dashboard for the 2021 filing. D.19-12-021 OP 5 requires PG&E to forecast administrative costs necessary to fulfill its role as fiscal agent to the RENs and to consider these costs separately in cost-effectiveness analysis starting in 2021. PG&E set up accounting mechanisms at the end of 2019 to track these costs and will be reporting these expenditures for program year 2020. PG&E has used its 2020 spend to date of \$58,799 for fiscal agent administrative costs through June 2020 (six months) to estimate an annualized cost (12 months) of \$117,598 for this work in program year 2021.

The budget to support these administrative costs is embedded in the total portfolio budget presented in Table 1 and not broken out separately in PG&E's 2021 ABAL forecast on CEDARS. Because PG&E's CEDARS forecast does not include a separate Program ID to capture these REN administrative costs distinct from the rest of its portfolio, these costs were not excluded from the TRC and PAC calculations in CEDARS. The portfolio TRC and PAC shown in Table 2 exclude REN administrative costs as directed by D.19-12-021. The exclusion of these costs does not materially impact the 2021 portfolio TRC and PAC values with or without codes and standards.

### *OBF Cost of Capital*

OBF cost of capital (COC) comprises a cost that is included in PG&E's advice letter TRC and PAC but excluded from the TRC and PAC on the CEDARS dashboard for the 2021 filing. PG&E calculated cost effectiveness for OBF using an approach consistent with PG&E's 2020 Supplemental ABAL and 2019 Second Supplemental ABAL,<sup>18</sup> in which COC is treated as an incentive cost, as these are funds that benefit customers that are not recouped through loan repayments.<sup>19</sup> As described in its 2020 ABAL, PG&E is reducing the cost of capital (COC) incentive amount by the complement of the net-to-

---

<sup>18</sup> Second Supplemental Advice 4011-G-B/5375-E-B, p.16 and Supplemental Advice 4136-G-A/5627-E-A, p.16.

<sup>19</sup> The cost of capital incentive forecast is a function of the 2021 forecasted OBF loan origination totals (equal to the OBF Alternative Pathway program forecast's gross measure cost total, against which loans will be sized) and a weighted average cost of capital (WACC) estimate of 7.5%.

gross (NTG) value (i.e. 1 - NTG) consistent with Commission policy on the TRC treatment of incentive costs because the COC benefits the non-freerider participants.<sup>20</sup> However, the COC is not a program incentive expenditure that appears in CEDARS, unlike the incentives for other programs, and is not a component of the portfolio budget. Thus, the total COC incentive costs of \$220,772 are not included in portfolio data filed on CEDARS, or in the TRC and PAC values calculated on CEDARS as a function of the filing data inputs. The inclusion of these COC incentive costs does not materially impact the 2021 portfolio TRC and PAC values with or without codes and standards.

**Table 3: Summary of Advice Letter and CEDARS Discrepancy Sources**

Discrepancy	Source	OBF Loan Pool Contribution Budget (\$17,000,000)	OBF COC Incentive Cost (\$220,772)	REN Fiscal Agent Administrative Support Costs (\$117,598)
PG&E Total Portfolio Budget	CEDARS Dashboard	Excluded	n/a	n/a
	Advice Letter	Included	n/a	n/a
PG&E Portfolio TRC and PAC, with and without C&S	CEDARS Dashboard	n/a	Excluded	Included
	Advice Letter	n/a	Included	Excluded

**Table 4: Summary of Advice Letter and CEDARS Value Discrepancies<sup>(a)</sup>**

Program ID	Total PG&E EE Portfolio Budget	TRC without C&S	PAC without C&S	TRC with C&S	PAC with C&S
CEDARS Dashboard	\$220,724,275	0.89	1.23	1.91	6.38
Advice Letter	\$237,724,275	0.89	1.23	1.91	6.38

(a) No discrepancies in TRC and PAC values are apparent between the CEDARS dashboard and the advice letter because the source of TRC and PAC calculation discrepancies involve relatively small forecasted cost amounts that do not materially impact the TRC and PAC values when rounded to the nearest hundredth.

## B. Business Plan Revision

As noted in Section III.A, PG&E forecasts a portfolio TRC of less than 1.0 without C&S or market effects for 2021, which triggers the requirement for PG&E to file a new business plan application per D.15-10-028, OP 2. PG&E triggered a new business plan application filing with its 2020 ABAL filed in 2019, in which it forecast a portfolio TRC of less than 1.0

<sup>20</sup> D.07-09-043 describes the role of NTG in the TRC calculation of net participant costs, with detailed TRC cost calculations showing the derivation of incentives x (1 - NTG) in D.07-09-043 Attachment 9.

without C&S or market effects. PG&E is not filing a new Business Plan application on September 1, 2020 because the CPUC has directed PG&E and the other California PAs to submit revised business plan applications on September 1, 2021, which will include considerations regarding the COVID-19 pandemic.<sup>21</sup>

### **C. Forecast Approach**

PG&E's 2021 ABAL reflects its continued focus on transitioning its portfolio to a predominantly third-party outsourced portfolio. This forecast assumes PG&E will achieve the 40% outsourcing target by December 31, 2020.<sup>22</sup> 2021 will be a year of transition, focusing on ramping down any remaining non-third-party qualified programs and ramping up new local and SW programs.

#### **New Local Programs**

PG&E signed new local programs across all five sectors (Industrial, Agricultural, Public, Commercial, and Residential) through the first wave of PG&E's local multi-sector third-party solicitation. The Industrial, Agricultural, and Public sectors are fully covered, while coverage for the commercial and residential sectors will be addressed in the second wave of PG&E's local multi-sector third-party solicitation that is currently underway. Because commercial and residential sector program contracts are still pending, this 2021 ABAL filing includes placeholder forecasts for new local programs in the commercial and residential sectors. Local Government Partnership (LGP) non-resource programs launched in July 2020 to support local governments, especially those serving HTR and DAC, as well as resource acquisition programs in the Public sector and are included in this 2021 forecast. All new local program forecasts for these sectors incorporate forecasts submitted by third parties that were awarded contracts through PG&E's solicitations. Third parties will have a greater responsibility to deliver verifiable and persistent energy savings and understand and abide by all policies and regulations that govern energy-efficiency programs and platforms.

#### **New Statewide Programs**

For SW programs, this 2021 ABAL forecast relies on forecasts provided by Lead PAs for programs in which PG&E is a funding PA, and includes PG&E-developed forecasts for those in which PG&E is the Lead PA. PG&E is the Lead PA for the following SW programs:

- Codes & Standards Advocacy (National, State Appliances, and Building Codes)
- New Construction (Residential and Non-Residential)
- Institutional Partnerships – State of California
- Workforce Education & Training (WE&T) – Career & Workforce Readiness
- Workforce Education & Training (WE&T) – Career Connections

---

<sup>21</sup> Amended Scoping Ruling Addressing Impacts of COVID-19 (Amended Scoping Ruling), issued July 3, 2020.

<sup>22</sup> D.18-01-004, OP 1



New Codes & Standards' National and State Appliance Advocacy programs launched in 2020, while a new Codes & Standards' Building Codes Advocacy program launched in 2019. The remaining PG&E-led SW programs are expected to launch in 2021.

While PG&E is the largest proportional load share contributor amongst the IOUs for SW programs, it is only the lead for two resource-acquisition SW programs<sup>23</sup> and therefore will be reliant on the other IOU Lead PAs to deliver cost-effective savings through their third-party implemented programs. PG&E will fund statewide programs as required<sup>24</sup> and therefore will receive energy savings credit based on this funding contribution. SW programs account for approximately 13.5% of the 2021 portfolio budget (excluding C&S, portfolio administrator costs and OBF loan pool) but 6% of PG&E's 2021 first-year net kWh savings forecast (excluding C&S), and approximately 12% PG&E's 2021 first-year net therm savings forecast (excluding C&S).

### Existing Programs

This 2021 ABAL forecast includes the following existing programs in Table 5 that qualify under the new third-party definition.<sup>25</sup>

**Table 5: Existing Programs that Qualify Under the New Third-Party Definition<sup>(a)</sup>**

2021 Program ID <sup>(a)</sup>	2021 Program Description <sup>(b)</sup>	Corresponding 2020 Program ID	Corresponding 2020 Program Description
PGE_Res_001a	Pay for Performance – Comfortable Home Rebates	PGE210010	Pay for Performance Pilot
PGE_Res_001b	Pay for Performance – Home Intel		
PGE_Res_001c	Pay for Performance – Home Energy Rewards		
PGE_Res_001d	Pay for Performance – Home Energy Optimization		
PGE_Res_002a	Residential Energy Advisor – Home Energy Check-Ups	PGE21001	Residential Energy Advisor
PGE_Res_002c	Residential Energy Advisor – Home Energy Reports		
PGE210212	Compressed Air and Vacuum Optimization Program (aka Industrial Compressed Air Systems Efficiency, or iCASE)	PGE210212	Compressed Air and Vacuum Optimization Program (aka Industrial Compressed Air Systems Efficiency, or iCASE)
PGE_SW_CSA_App	State Appliance Standards Advocacy	PGE_SW_CSA_App	State Appliance Standards Advocacy
PGE_SW_CSA_Bldg	State Building Codes Advocacy	PGE_SW_CSA_Bldg	State Building Codes Advocacy
PGE_SW_CSA_Natl	National Codes & Standards Advocacy	PGE_SW_CSA_Natl	National Codes & Standards Advocacy

<sup>23</sup> New Construction and Institutional Partnerships (State of California and Department of Corrections and Rehabilitation).

<sup>24</sup> D.18-05-41, OP 22.

<sup>25</sup> D.16-08-019, OP 10

---

(a) “Existing programs” in this table refers to programs that were operating in 2020 and will continue to operate in 2021. New Codes & Standards National and State Appliance Standards Advocacy contracts awarded via Solicitation in Q1 2020 and therefore are existing programs that will continue into 2021. New State Building Codes Advocacy contracts were awarded in 2019 and will continue into 2021.

(b) The 2020 Pay for Performance Pilot program (PGE210010) is broken out into four separate Program IDs for each implementer (PGE\_Res\_001a, PGE\_Res\_001b, PGE\_Res\_001c, and PGE\_Res\_001d) for the 2021 ABAL filing. Similarly, the 2020 Residential Energy Advisor Program (PGE21001) is broken out into three separate Program IDs for each subprogram (PGE\_Res\_002a, PGE\_Res\_002b, and PGE\_Res\_002c) for the 2021 ABAL filing. Only programs PGE\_Res\_002a for Home Energy Check-Ups and PGE\_Res\_002c for Home Energy Reports are included in this table. See Section III.G. of this advice letter for more details on Program ID changes resulting from Program ID Reorganization.

This forecast also includes existing non-third-party qualifying programs (both PG&E-implemented and vendor-implemented programs). PG&E is extending and continuing budget for select vendor-implemented existing programs to ensure portfolio flexibility to address impacts from the COVID-19 pandemic and ensure customer coverage until the new local and SW programs ramp up in 2021 or beyond. PG&E-implemented programs remain in the portfolio in 2021 to close out existing pipelines of already committed customer projects or to serve customers who may not be served by one of the third party implemented programs.

PG&E is also forecasting the continuation of the Home Energy Reports behavioral program offering of the Residential Energy Advisor program for part of 2021. While a new residential behavioral program is expected to be under contract by the end of 2020 and launch in 2021, replacing the current Home Energy Reports program, PG&E anticipates its current Home Energy Reports program to operate in 2021 before the new program ramps up. As discussed under the 2021 Program Changes of this advice letter (Section III.G), PG&E will be splitting up its 2020 Residential Energy Advisor Program ID (PGE21001) into three separate Program IDs for 2021 to distinguish among distinct Residential Energy Advisor program offerings; these new 2021 Program IDs are listed in Table 12 of Section III.G. One of these new 2021 Program IDs (PGE\_Res\_002c) will cover the Home Energy Reports component of the Residential Energy Advisor program,<sup>26</sup> for which program activity is forecasted for at least the first quarter of 2021. PG&E has also included a placeholder forecast for the new third-party residential program that has yet to be contracted, but will be operating in 2021, captured under a third-party residential placeholder Program ID (PGE\_3P\_Res). The forecasts for the existing Home Energy Reports program (PGE\_Res\_002c) and the new residential behavioral placeholder (PGE\_3P\_Res) reflect the expected transition from the existing to the new residential behavioral program.

---

<sup>26</sup> Per Table 12 in Section III.G., the new 2021 Program ID for the Home Energy Reports component of the 2020 Residential Energy Advisor program will be “PGE\_Res\_002c” with the accompanying 2021 program name “Residential Energy Advisor - Home Energy Reports”.

## **D. COVID-19 Considerations**

PG&E developed this 2021 ABAL forecast amidst a period of unprecedented economic and market uncertainty due to the global pandemic caused by COVID-19. While it is impossible to confidently predict the precise impact of the pandemic on PG&E's EE portfolio or individual customer sectors, PG&E observed the following trends in the residential and non-residential sectors of its EE portfolio and has adjusted some of its approaches to customer engagement as a result. Because the extent and duration of the impact of the COVID-19 global pandemic is uncertain, PG&E will strive to remain flexible in its COVID-19 response.

### **Residential Trends**

Since Governor Newsom issued the statewide Shelter-in-Place (SIP) order on March 19, 2020, residential energy usage increased as Californians stayed home. Based on a July 2020 report by the California Energy Commission, residential energy usage increased by approximately 15% year-to-date compared to the same period in 2019.<sup>27</sup> As a result, residential customers want tips on how to save energy and information on home energy usage, high bill alerts, and EE programs.<sup>28</sup> PG&E's residential sector savings continue to be driven by behavioral programs which, to date, have not seen a decline in forecasted savings due to the pandemic. SIP poses a challenge to completing certain program installations, such as for direct install (DI) programs. As cities and counties reopen in California, customers and contractors continue to observe local and state guidelines to ensure that safe installations can occur. In this period of uncertainty and economic downturn, the needs of Hard-to-reach (HTR) and Disadvantaged Communities (DAC) may be more pronounced as the economic impacts are likely most heavily felt by those communities.

### **Residential Actions**

In 2020, in recognition of the shift in the way residential customers are using energy, PG&E worked both internally and with third-party residential program implementers on several actions that are expected to continue in some capacity into 2021 and are reflected in this 2021 ABAL forecast. These actions include increased communications with regular COVID-19 support emails approximately every 10-20 days, which are sent to roughly 3.3 million customers. PG&E's COVID-19 Customer Support Outreach highlights billing and service modifications, safety tips, financial assistance programs, online tools for energy use, and low- or no-cost energy-efficiency programs and energy-savings tips. PG&E expanded the number of customers receiving Home Energy Reports (HERs), adding 160,000 customers. HERs now serves a total of 1.8 million customers, which consists of approximately 40% income-qualified customers and 60% non-income qualified customers. PG&E also plans to add a new feature to the HERs program called Bill Forecast Alerts (BFAs) that will alert customers who reach a certain billing or energy

---

<sup>27</sup> [https://www.energy.ca.gov/sites/default/files/2020-07/Energy%20Insights\\_FINAL%2007-17-2020.pdf](https://www.energy.ca.gov/sites/default/files/2020-07/Energy%20Insights_FINAL%2007-17-2020.pdf)

<sup>28</sup> Oracle Customer Survey, May 2020.

usage threshold and provide behavioral tips to reduce their usage. PG&E believes that these expansions of HERs will support customers impacted by COVID-19 while also driving cost-effective savings for the portfolio.

Additionally, PG&E expanded the service area for one of its Residential Pay-for-Performance Programs, the Home Energy Rewards program, from serving two counties to PG&E's entire service area. This program provides free energy kits to customers and a significantly reduced price for smart thermostats, among other benefits.

### **Non-Residential Trends**

As Californians stayed home with the March 2019 SIP order and electricity consumption shifted from non-residential to residential, the impact to non-residential industries varied based upon factors such as their designation as an "essential" business, or the level of vulnerability to the impacts of decreased in-person business activities.

The economic impact to "essential" businesses such as grocery stores, laboratories, data centers, and communications has been positive, given that these businesses remain open and have seen an increase in demand. However, many businesses whose models are heavily reliant on in-person business activities such as hospitality, restaurants, retail, etc. - that are not deemed "essential" - have been negatively impacted, triggering additional economic hardship for the businesses as well as the individuals who are now unemployed in these industries.<sup>29</sup> These economic forces are severely impacting demand, discretionary spending, and supply chains, and may force some businesses to transform their business models. The uncertain future for many businesses increases the perceived risk from financial institutions that provide access to capital, resulting in higher costs for those businesses to borrow money as well as impacts to their ability or desire to spend available capital on EE projects.

Before Governor Newsom's recently enacted revised budget, there was a projected \$54 billion budget deficit due to sharply reduced state revenues, increased costs in health and human services programs, and added costs to address COVID-19.<sup>30</sup> The enacted budget places an emphasis on public health and safety, and promotes economic recovery, particularly for small businesses. With critical federal funding to aid state and local governments still uncertain, there is a trickle-down impact to areas reliant on this funding such as K-12 schools and higher education, particularly for EE investments.

---

<sup>29</sup> As of June 2020, California's unemployment rate of 14.9%, while lower than the record high of 16.4% in May 2020, is still far higher than the 12.3% during the height of the Great Recession in 2010. More information accessible via <https://www.edd.ca.gov/newsroom/unemployment-july-2020.htm>.

<sup>30</sup> <http://www.ebudget.ca.gov/2020-21/pdf/Enacted/BudgetSummary/FullBudgetSummary.pdf>

**Non-Residential Actions**

On March 16, 2020, seven Bay Area jurisdictions<sup>31</sup> enacted stay-at-home orders beginning March 17, 2020. On March 20, 2020 PG&E's EE programs issued "stop work" orders to contractors providing home and other in-person EE and weatherization upgrades in alignment with the statewide SIP guidelines. On June 1, 2020, based on State and CPUC guidance, PG&E's EE Programs resumed in-person work in accordance with local and state SIP guidelines, requiring contracted implementers to obtain written customer authorization to visit their site, and document and adhere to State and local safety guidance - whichever is more restrictive. PG&E is prepared to take similar action and re-instate a pause to EE programs should conditions warrant such a response. Going forward, PG&E will continue to prioritize the health and safety of its customers, employees, and contractors, while actively monitoring performance across its portfolio.

Given the financial and capital constraints that many businesses are experiencing, PG&E's financing programs such as On-Bill Financing (OBF) offer non-residential customers increased access to affordable capital to invest in EE upgrades to their businesses without upfront capital, while remaining cash flow neutral. Unlike traditional rebate and incentive programs where a customer must otherwise have the capital to invest in the project, financing offers customers the ability to make an EE investment when they may not have otherwise been able to make one. OBF uses a revolving loan pool: as OBF funds are repaid, they are re-issued in the form of new loans with new projects, providing greater leverage for ratepayer funds. This structure enables the continued investment in EE projects without significant impacts to the EE portfolio budget and budget recovery request.

PG&E is requesting an increase of \$3,500,000 in the OBF loan pool contribution relative to the 2020 ABAL for a total of \$17,000,000 to ensure that the revolving loan pool is sufficiently funded to accommodate the potential for increased demand. For example, local governments will continue to have a role to play in helping California achieve its ambitious climate goals, and many have Climate Action Plans that they will still need to pursue while managing within the global pandemic. The increases to PG&E's OBF loan pool and the potential to make loans of up to \$4,000,000 available, by exception, for projects with unique energy savings opportunities,<sup>32</sup> can be leveraged to support these local governments pursue activities within their respective Climate Action Plans.

To support customers in this challenging economic landscape, PG&E anticipates the potential for increased budget for the same/similar levels of savings for programs that would be achieved in the absence of the pandemic. As noted in Section III.C, this 2021 ABAL forecast includes existing program extensions to ensure portfolio flexibility to address impacts from the COVID-19 pandemic.

---

<sup>31</sup> Jurisdictions include Alameda, Contra Costa, Marin, San Francisco, San Mateo, and Santa Clara counties, and City of Berkeley.

<sup>32</sup> D.19-03-001, p. 2.

## **E. Cost-Effectiveness Challenges**

As noted in Section III.A, PG&E is forecasting a portfolio TRC of 0.89 without C&S or market effects for 2021. PG&E's 2021 portfolio reflects a 25% increase in cost-effectiveness relative to its 2020 ABAL forecasted TRC of 0.71 without C&S or market effects.<sup>33</sup> However, PG&E's portfolio still faces cost-effectiveness challenges including the diminished availability of high-volume measures with positive net benefits, the downward trend of avoided costs, the inclusion of non-resource programs and costs in PG&E's portfolio that must be offset by resource program benefits, and the exclusion of C&S from the threshold TRC and PAC tests. As a result of the cost-effectiveness challenges below, PG&E is not forecasting a cost-effective portfolio in 2021. In addition, PG&E's portfolio cost-effectiveness may likely be further impacted by COVID-19 pandemic uncertainty during portfolio implementation.

### **Diminished Availability of High-Volume, Positive-Net-Benefit Measures**

PG&E's recent portfolios through 2019 were heavily reliant on programs such as Primary Lighting to contribute significant, positive net benefits.<sup>34</sup> Historically, these high-volume measures with positive net benefits have been critical to bringing in enough portfolio TRC benefits to offset the multitude of TRC costs in the portfolio. While the Residential Lighting savings potential and associated positive net benefits were eliminated from incentive programs, these savings have been absorbed by the C&S programs. The C&S absorption of measures that were previously highly cost-effective in incentive programs has outpaced the creation of cost-effective opportunities in incentive programs. This has contributed to the challenges in achieving a cost-effective portfolio without the inclusion of C&S benefits.

### **Downward Trend of Electric Avoided Costs**

Electric avoided costs comprise a majority of PG&E's energy-efficiency portfolio benefits, and the downward trend in the value of electric avoided cost benefits since 2017 has presented a significant challenge to achieving a cost-effective portfolio. Although average electric avoided cost benefits have increased with the 2020 avoided cost update<sup>35</sup> relative to the 2019 avoided cost update, mid-day electric avoided cost benefits have decreased substantially relative to pre-2017 avoided costs, resulting in fewer avoided cost benefits realized for a given kilowatt-hour of electricity saved in the EE portfolio.

### **Non-Resource and "Policy-Driven" Programs**

The IOUs are expected to fund activities outside of EE resource acquisition such as non-resource (e.g. workforce education and training) and policy programs focused on policy

---

<sup>33</sup> Advice 4136-G/5627-E filed September 3, 2020, and Advice 4136-G-A/5627-E-A, filed November 15, 2019. Non-standard disposition of Advice 4136-G/5627-E and Advice 4136-G-A/5627-E-A dated December 20, 2019 and issued on December 24, 2019.

<sup>34</sup> Net TRC Benefits = Benefits – TRC Costs.

<sup>35</sup> Resolution E-5077 adopted updates to the avoided cost calculator for use in demand-side distributed energy resources cost-effectiveness analyses.

objectives (e.g. social equity programs such as those aimed at serving HTR, DAC and market transformation programs designed to achieve long-term EE savings impacts in support of state climate goals). However, these programs do not produce immediately quantifiable cost-effective savings while contributing to portfolio costs in the threshold portfolio TRC calculation. EE portfolios are expected to fund these activities in addition to programs focused on EE resource acquisition, while also cost-effectively delivering on energy savings goals within budget.<sup>36</sup> However, non-resource programs may not necessarily play any role in achieving cost-effective energy savings goals because they do not provide direct energy savings and only have costs, yet frequently provide necessary support to resource programs.<sup>37</sup>

### **Exclusion of C&S from Threshold TRC and PAC Tests**

Another challenge in meeting portfolio cost-effectiveness goals is that savings from C&S activities are not included in the threshold portfolio TRC and PAC tests. When the Commission confirmed the exclusion of C&S from the threshold TRC and PAC tests in 2012,<sup>38</sup> C&S composed a small part of the EE portfolio, but that is no longer the case. After years of effective advocacy for C&S by the PAs, many measures have successfully led to implementation through C&S. For example, C&S savings accounted for only 9% of total savings in the 2006 – 2008 program cycle;<sup>39</sup> however, C&S savings were forecasted to be 63% of first-year net GWh for the 2020 statewide portfolio.<sup>40</sup> The role of C&S as a “bonus” contributor to the overall EE portfolio no longer reflects the magnitude of savings and benefits that C&S delivers relative to the rest of the EE portfolio. PG&E has recognized C&S as one of the most cost-effective channels for EE interventions and has invested accordingly; however, this disparity between the C&S and non-C&S portfolios will grow as a result of this investment. Thus, the more successful PG&E is at using C&S to drive savings at lower cost, the more challenging it is for the remaining portfolio to be cost-effective.

## **F. Portfolio Strategies to Improve Cost-Effectiveness in 2021**

### **Portfolio Management and Balancing**

PG&E pursues portfolio management tactics to address cost-effectiveness in its portfolio. PG&E emphasizes cost-effective programs and encourages innovative and market-driven solutions through its third-party solicitations. As PG&E transitions its portfolio towards the 60% outsourcing target by the end of 2022,<sup>41</sup> it has prioritized the introduction

---

<sup>36</sup> D.18-05-041 Findings of Fact 16.

<sup>37</sup> D.12-05-015, p.11

<sup>38</sup> D.12-11-015, p.99.

<sup>39</sup> D.12-05-015, p. 85.

<sup>40</sup> Budget Filing Detailed Report for program year 2020, downloadable from the CPUC's CEDARS website.

<sup>41</sup> D. 18-01-004, OP 1

of new local and statewide third-party programs over maintaining existing programs. In order to optimize and balance the portfolio, PG&E also manages budget allocations for activities outside of EE resource acquisition to mitigate against the negative net benefits incurred by these expenditures in the portfolio. Lastly, PG&E intends to monitor the impact of its statewide programs on cost-effectiveness.

As noted in Section III.C, while PG&E is the largest proportional load share contributor amongst the IOUs for statewide programs, it is only the lead for two resource-acquisition statewide programs,<sup>42</sup> and therefore will be reliant on the other Lead IOUs to deliver cost-effective savings through their third-party implemented programs. PG&E will fund statewide programs as required<sup>43</sup> and therefore receive energy savings credit based on this funding contribution. Should those programs underperform, PG&E will need to re-balance and adjust for that underperformance within the program year by relying more on its local resource programs. Or, in the event that they overperform, this may enable PG&E to rely less on its local resource programs.

In addition to the non-resource programs mentioned above, PG&E's portfolio administrator costs required to run its EE portfolio are included in the threshold portfolio TRC calculation and must be offset by resource-acquisition program benefits. PG&E is committed to continuing to thoughtfully manage its portfolio administrator costs, as demonstrated by the 30% reduction in total portfolio administrator costs between 2018 and 2021.<sup>44</sup> As PG&E's portfolio begins its transition to a predominantly outsourced portfolio, as portfolio administrator, PG&E will provide portfolio and program oversight, and assist third-party providers with other support services to improve program offerings, avoid administrative redundancies, and ensure regulatory compliance. To accomplish this, PG&E will retain portfolio-related costs associated with program/portfolio administration responsibilities that align with PG&E's regulatory and fiduciary responsibilities as stewards of ratepayer funds, as well as those portfolio administration responsibilities critical to the achievement of portfolio goals. These costs typically do not vary greatly based on the number or scale of programs in the portfolio. Examples of portfolio-related costs include oversight roles such as regulatory compliance; savings and financial reporting; portfolio optimization; evaluation, measurement and verification (EM&V) support; and IT investments.

Program-related portfolio administrator costs are those that more directly support programs within PG&E's portfolio and vary based upon the number or scale of programs. Examples of these costs include roles such as engineering reviews, quality assurance

---

<sup>42</sup> New Construction and Institutional Partnerships (State of CA, Department of General Services, and Department of Corrections and Rehabilitation)

<sup>43</sup> D.18-05-41 OP 22.

<sup>44</sup> PG&E's portfolio administrator costs are comprised of the functional groups in Attachment 3, Appendix I.A.5, excluding third-party implementer contract costs, local government partnership contract costs, program implementation non-labor costs, and incentive costs.



and quality control (QA/QC), contract management, account management/sales and marketing, education, and outreach (ME&O). Starting in 2021, when possible, PG&E will be tracking program-related costs as direct charges to individual programs to more accurately allocate program-related portfolio administrator costs to the specific program supported by PG&E staff.

### **Responding to Changing Market and Regulatory Conditions**

Many of the market and regulatory conditions under which PG&E's EE portfolio operates are outside of its control. Thus, PG&E is focusing on opportunities relatively within its control to respond to those inevitable changing conditions. PG&E will continue to actively participate in regulatory proceedings that may be impactful to cost effectiveness and long-term success of the EE portfolio. Additionally, in anticipation of (a) market or regulatory conditions that may substantially impact programs, and (b) opportunities to monitor ongoing program performance, PG&E will continue annual program reviews and will realign programs as necessary. Lastly, as customers seek on-bill financing support for their projects amidst the current economic uncertainty, PG&E has instituted cost-effectiveness requirements for large on-bill financing projects to help balance customer and portfolio cost-effectiveness needs.

### **Portfolio Administrator Activities**

Acting as a portfolio administrator of a majority-outsourced portfolio necessitates strong QA/QC in the selection of those third-party programs via solicitations and for program performance once launched. PG&E will continue to provide critical oversight activities to ensure that ratepayer funds are prudently used. PG&E will ensure that savings claims of third-party implementers are reasonable, accurate, and in compliance with CPUC policy. PG&E expects this responsibility to increase with the expansion of third-party implemented programs. QA/QC program performance and ex ante/ex post alignment. Additionally, PG&E is aligning stakeholder interests on cost-effective offerings and projects through contract terms that encourage performance-based payments. To facilitate this, PG&E is investing in IT system changes to enable effective contract management.

## **G. 2021 Program Changes**

This section identifies changes to PG&E's proposed programmatic activity in compliance with D.15-10-028 and D.18-05-041. PG&E met its first major third-party program outsourcing milestone requirement as of June 30, 2020,<sup>45</sup> with 25% of its EE portfolio budget now under contract to third-party implementers pending Commission review of PG&E's Tier 2 advice letters seeking approval of new third-party contracts valued at \$5 million or more and/or with a contract duration longer than three years.<sup>46</sup> The portfolio

---

<sup>45</sup> D.18-05-041, OP4.

<sup>46</sup> D.18-01-004, OP 5.

balancing necessary to onboard these new programs, which are expected to support PG&E's portfolio cost-effectiveness goals, requires the ramp down and closure of existing programs.<sup>47</sup>

The program budget changes described in the section reflect budgets that changed by 40% or more relative to program budgets approved in its 2020 ABAL in accordance with D.18-05-041 OP 41 and section 7.2.<sup>48</sup> Program changes and closures are detailed in the following sections and summarized in Attachment 2 to this advice letter.

### **Programs to be closed immediately with the disposition of the 2021 ABAL**

PG&E intends to close fourteen existing programs starting in 2021, pending the disposition of this advice letter. These programs, shown in Table 6 below, are closing as a result of overlap with the new local third-party and/or statewide programs that are expected to be active in 2021, and to make room in the portfolio for new programs that qualify under the new third-party definition.<sup>49</sup> These programs are not included in PG&E's 2021 ABAL CEDARS filing.

**Table 6: Programs to be Closed Immediately with the Disposition of the 2021 ABAL**

<b>Program ID</b>	<b>Program Name</b>	<b>Closure Date</b>
PGE21008	Enhance Time Delay Relay	12/2020
PGE210011	Residential Energy Fitness Program	12/2020
PGE21003	Multifamily Energy Efficiency Program	12/2020
PGE21009	Direct Install for Manufactured and Mobile Homes	12/2020
PGE210112	School Energy Efficiency	12/2020
PGE210123	Healthcare Energy Efficiency Program	12/2020
PGE210135	Water Infrastructure and System Efficiency (WISE)	12/2020
PGE21015	Commercial HVAC	12/2020
PGE21018	EnergySmart Grocer Program	12/2020
PGE21026	Energy Efficiency Services for Oil Production	12/2020
PGE210311	Process Wastewater Treatment Energy Management Program for Ag Food Processing	12/2020
PGE210312	Dairy and Winery Industry Efficiency Solutions	12/2020

<sup>47</sup> For the purposes of this 2021 ABAL, a "closed" program is no longer accepting new applications. Unless otherwise noted, a closed program may still have program spend and savings claims into 2021 and beyond, in order to meet outstanding program commitments and complete project pipelines in place prior to closure.

<sup>48</sup> See Attachment 4, Appendix Table 4 for the 2021 budgets associated with these programs.

<sup>49</sup> D.16-08-019, OP 10.

PGE21039	Comprehensive Food Process Audit & Resource Efficiency (CFP)	12/2020
PGE2110052	Strategic Energy Resources	12/2020
PGE21061	Technology Development Support	12/2020
PGE21076	Career and Workforce Readiness <sup>(a)</sup>	12/2020
PGE21041	Primary Lighting	12/2019 <sup>(b)</sup>
PGE21042	Lighting Innovation	12/2019 <sup>(b)</sup>
PGE21051	Building Codes Advocacy	12/2020 <sup>(c)</sup>
PGE21052	Appliance Standards Advocacy	12/2020 <sup>(c)</sup>
PGE21057	National Codes and Standards Advocacy	12/2020 <sup>(c)</sup>

(a) The Career and Workforce Readiness program had no program expenditures in PY2019 and has no program expenditures to date in PY2020. This program was set up in 2019 in anticipation of supporting the launch of the SW WE&T Career and Workforce Readiness program that was ultimately delayed until 2021. This program is being sunset now that the new SW WE&T Career and Workforce Readiness program is launching in 2021 (see Table 10 below).

(b) The Primary Lighting Program (PGE21041) and Lighting Innovation Program (PGE21042) ceased program activity at the end of 2019, however there were residual expenditures in early 2020. In 2019, the Primary Lighting Program was an upstream lighting program focused primarily on incentivizing the manufacture of advanced light-emitting diodes (LEDs). D.19-08-034 adopted goals that updated the baseline for residential lighting to LEDs effective January 1, 2020, significantly reducing the cost-effective savings potential for this program. PG&E indicated in its 2020 ABAL that no program activities were expected for the Primary Lighting Program in 2020, but did not formally close the program until Southern California Edison (SCE) as the SW Lead closed its Primary Lighting Program, which was signaled in its 2020 ABAL (Advice 4068-E). The Lighting Innovation Program was a non-resource program that evaluated products or program approaches new to the lighting market for eventual transfer to EE portfolios. PG&E completed its last trial study for this Program in 2019 and requests to formally close this program via this advice letter, following the SW lighting lead SCE in its closure of the Lighting Innovation Program in its 2019 ABAL (Advice 3859-E). Any future research on advanced lighting can be administered via the Emerging Technologies Program. A new SW lighting program is launching in 2021; see program PGE\_SW\_UL in Table 10 of this advice letter.

(c) The C&S Building Codes Advocacy program (PGE21051), Appliance Standards Advocacy program (PGE21052), and National Codes and Standards Advocacy program (PGE21057) are being replaced by the new statewide programs PGE\_SW\_CSA\_Bldg, PGE\_SW\_CSA\_App, and PGE\_SW\_CSA\_Natl, respectively. These new SW programs are shown in Table 8.

Additionally, PG&E notes that activities from the Energy Upgrade California program (PGE21004, known as Advanced Home Upgrade) and the Residential HVAC program (PGE21006) were moved to the Residential Pay for Performance program, which includes similar offerings and opportunities for operational efficiencies as a result of the consolidation. The Program IDs for these programs will be retired in CEDARS, however the program activities will continue under the additional program as described. See the section below titled "Program ID Changes Resulting from Program ID Reorganization" for more details on this transition.

### Programs to be Closed Upon Completion of Commitments

PG&E's 2021 ABAL forecast includes budgets for many programs that it plans to close upon completion of program commitments, notwithstanding any unforeseen impacts or customer needs associated with the COVID-19 pandemic. The programs are in the

process of ramping down, in most cases as a result of overlap with new, local third-party programs and/or statewide programs ramping up in 2021.

**Table 7: Programs to be Closed Upon Completion of Commitments**

Program ID	Program Name	% Budget Change from 2020	Reason for Closure	Contract Extension Date	Explanation
PGE2110051	Local Government Energy Action Resources (LGEAR)	-72%	New local third-party and/or statewide program overlap	09/2021	Previous Energy Watch programs, funded through LGEAR, will ramp down and close direct install programs by the end of 2020, but select contracts have been extended into 2021 to gap-fill for incoming third-party programs.
PGE210210	Industrial Retro-commissioning Program	+6%	New local third-party and/or statewide program overlap	2021 (Month TBD)	Finishing existing pipeline and ramping down in anticipation of new third-party program overlap.
PGE21036	Industrial Refrigeration Performance Plus (IRPP)	N/A <sup>(a)</sup>	Low savings achievement	2021 (Month TBD)	PG&E's 2019 EE Annual Report filed May 1, 2020 noted this program was expected to ramp down and close by 2021. Budget ramp-down for closing out project costs was also mentioned in PG&E's 2019 and 2020 ABALs as well as Appendix B of PG&E's 2020 ABAL workshop presentation. <sup>(a)</sup>
PGE211025	Savings by Design	+10%	New local third-party and/or statewide program overlap	n/a <sup>(b)</sup>	Finishing existing project pipeline in anticipation of SW replacement program. Program not accepting new applications.
PGE210143	Hospitality Program <sup>(c)</sup>	+21%	New local third-party and/or statewide program overlap	06/2021	New local Commercial resource program(s) are expected to replace this program upon launch in mid-2021. Extended into 2021 to ensure customer coverage due to COVID-19 impacts.
PGE21027	Heavy Industry Energy Efficiency Program	-66%	New local third-party and/or statewide program overlap	2021 (Month TBD)	Ramping down in anticipation of new third-party program overlap.
PGE21092	Third-Party Financing	0% <sup>(d)</sup>	No future program spending expected	2021 or 2022 (Month and Year TBD)	Contract still in place for management of remaining third-party loan pool, however no 2021 spend expected.
PGE21005	Residential New Construction - California Advanced Homes Program	-59%	New local third-party and/or statewide program overlap	12/2021	This program will be replaced by a new SW Residential New Construction program. Per notes in PG&E AL 4270-G/5867-E, the Advanced Energy Rebuild portion of this program will close to new applications at the end of 2020, with existing project pipeline to complete in 2021.
PGE2110011	California Community Colleges	+73%	New local third-party and/or statewide program overlap	2022 (Month TBD)	Increased budget to finish large existing projects continuing into 2021 or 2022. Ramping down in anticipation of new SW program overlap.
PGE2110012	University of California/Calif-	+363%	New local third-party and/or	2022 (Month TBD)	Increased budget to finish large existing projects continuing into 2021 or 2022.

	ornia State University		statewide program overlap		Ramping down in anticipation of new SW program overlap.
PGE2110013	State of California	+24%	New local third-party and/or statewide program overlap	2021 (Month TBD)	Increased budget to finish large existing projects continuing into 2021. Ramping down in anticipation of new SW program overlap.
PGE2110014	Department of Corrections and Rehabilitation	+53%	New local third-party and/or statewide program overlap	2021 (Month TBD)	Increased budget to finish large existing projects continuing into 2021. Ramping down in anticipation of new SW program overlap.

(a) The IRPP budget change is shown as "N/A" because \$0 were forecast for the 2020 ABAL, and approximately \$25k is forecasted for 2021. The long project close-out process has resulted in final project costs occurring in 2021 despite \$0 budget in 2020 as noted in PG&E's 2020 ABAL, Advice 4136-G-A/5627-E-A, p.18. PG&E's 2020 ABAL workshop presentation Appendix B also noted this program would "close upon completion of commitments" (presentation distributed to the EE service lists R.13-11-005 and A.17-01-013 on May 6, 2020). Lastly, PG&E's 2019 ABAL discussed a planned sunset of this program in Advice 4011-G/5373-E p.27, and via second supplemental Advice 4011-G-B/5373-E p.3 noted this program was forecasted with continued 2019 budget to enable a small number of project completions.

(b) The Savings by Design program does not have an implementer contract, thus this field is marked as "n/a"; however, the program ramp-down is expected to be complete by 2022.

(c) The Hospitality Program primarily serves the hospitality sector but has evolved over the past three years to also serve grocery, small retail, office, and restaurant sectors as well. While the hospitality sector has been heavily impacted by COVID-19, other sectors have contributed to the remaining program pipeline. This program will be closing upon completion of its committed projects and is expected to sunset in June of 2021. The program name is not adjusted in the table above due to the cost to implement this change. The 2021 forecast reflects a budget increase from the 2020 ABAL, however due to incrementally cost-effective savings opportunities in 2020, the program's funding increased relative to the 2020 ABAL program forecast. The 2021 ABAL budget is a reduction relative to the 2020 operational budget.

(d) The Third-Party Financing program budget change is shown as "0%" because \$0 were forecasted for the 2020 ABAL, and \$0 are forecasted for the 2021 ABAL. While no spend is anticipated in 2021 for this program, the Program ID will remain "active" in 2021 because there is currently an active third-party contract in place for the management of third-party loan pool funds, and future spend is possible in this program but will be handled through fund-shifting if needed. PG&E's 2020 ABAL workshop presentation Appendix B also noted this program would "close upon completion of commitments" (presentation distributed to the EE service lists R.13-11-005 and A.17-01-013 on May 6, 2020).

### Programs with Budget Changes of 40% or More Relative to the 2020 ABAL

Several programs have 2021 budgets that have decreased by 40% or more relative to PG&E's 2020 ABAL, shown in Table 8 below. The first three programs in this table, as noted in the explanation column, are PG&E-implemented and will continue to operate through the duration of 2021 to fill portfolio gaps and support customer needs as the portfolio ramps up new third-party local and statewide programs. These PG&E-implemented programs will eventually close in future program years, which will be signaled in PG&E's 2022 ABAL and/or 2023-2026 Business Plan application to be filed on September 1, 2021.

**Table 8: Programs with Budgets Decreased by 40% or More**

Program ID	Program Name	% Budget Change from 2020	Driver of Budget Reduction	Explanation
PGE21002	Residential Energy Efficiency	-83%	New local third-party and/or statewide program overlap	Ramping down due to overlap with SW Plug Load and Appliance program (PGE_SW_PLA). Program will operate through the majority of 2021. Future closure for this PG&E-implemented program may be signaled in 2022 ABAL depending on portfolio needs.

PGE21012	Commercial Deemed Incentives	-54%	New local third-party and/or statewide program overlap	Ramping down while fulfilling existing project commitments and gap-filling for new third-party programs. Program will operate through duration of 2021. Future closure for this PG&E-implemented program may be signaled in 2022 ABAL depending on portfolio needs.
PGE21034	Agricultural Energy Advisor	-88%	New local third-party and/or statewide program overlap	The Advanced Pumping Energy Efficiency Program (APEP) component of this subprogram is moving under Integrated Energy Education and Training (PGE21071) to align non-resource program activities. Program will operate through duration of 2021. Future closure for this PG&E-implemented program may be signaled in 2022 ABAL depending on portfolio needs.
PGE21062	Technology Assessments	-53%	New local third-party and/or statewide program overlap	Ramping down due to overlap with SW Emerging Technologies Program (PGE_SW_ETP_Gas) and in anticipation of new SW electric Emerging Technologies program.

Table 9 shows programs with 2021 budgets that increased by 40% or more relative to PG&E's 2020 ABAL. Most of the existing programs in this table show increased budget to cover costs of finishing existing projects and filling in gaps in the portfolio as new programs come on board.

**Table 9: Programs with Budgets Increased by 40% or More**

Program ID	Program Name	% Budget Change from 2020	Explanation
PGE_3P_Com	Third-Party Placeholder – Local Commercial Programs	+135%	The placeholder budget for new local third-party commercial programs not yet under contract is higher in 2021 than 2020 because these new programs are expected to be under contract by the end of 2020 and launching in 2021. The budget forecasted for 2020 was lower due to solicitations timing, which ultimately was delayed past the date expected for the 2020 ABAL.
PGE_3P_Res	Third-Party Placeholder – Local Residential Programs	+74%	The placeholder budget for new local third-party residential programs not yet under contract is higher in 2021 than 2020 because a new residential behavioral program is expected to be under contract by the end of 2020 and launching in 2021. The budget forecasted for 2020 was lower due to solicitations timing, which ultimately was delayed past the date expected for the 2020 ABAL.
PGE_SW_CSA_App	State Appliance Standards Advocacy	+110%	New statewide program ramping up. The 2021 budget reflects additional program administrator costs for 2021 (relative to the 2020 ABAL forecast), including Applied Technology Services support of C&S advocacy subprograms.
PGE_SW_CSA_Bldg	State Building Codes Advocacy	+55%	New statewide program ramping up. The 2021 budget reflects additional program administrator costs for 2021 (relative to the 2020 ABAL forecast), including Applied Technology Services support of C&S advocacy subprograms.

PGE_SW_CSA_Natl	National Codes & Standards Advocacy	+40%	New statewide program ramping up. The 2021 budget reflects additional program administrator costs for 2021 (relative to the 2020 ABAL forecast), including Applied Technology Services support of C&S advocacy subprograms.
PGE_SW_NC_NonRes	SW New Construction Non-Residential	+57%	New statewide program ramping up.
PGE_SW_NC_Res	SW New Construction Residential	+539%	New statewide program ramping up. Low 2020 budget forecasted in 2020 (\$456k) due to anticipated start in late 2020, however new program launch delayed to 2021.
PGE_Res_001a <sup>(a)</sup>	Pay for Performance (CHR, HEA, HER, and ICF) <sup>(a)</sup>	+57%	Program budget increase reflect funds needed to cover 2021 M&V payments resulting from prior-year projects, and increased participant enrollment in 2021. Additionally, program activities from Energy Upgrade California (PGE21004) and Residential HVAC (PGE21006) have moved under the Pay for Performance-CHR new 2021 Program ID (PGE_Res_001a). See the "Program ID Changes Resulting from Program ID Reorganization" section and accompanying Table 11 below for more details.
PGE_Res_001b <sup>(a)</sup>			
PGE_Res_001c <sup>(a)</sup>			
PGE_Res_001d <sup>(a)</sup>			
PGE210212	Compressed Air and Vacuum Optimization Program	+174%	The 174% budget increase reflects an absolute budget increase of approximately \$505k to cover project commitments.
PGE21022	Industrial Deemed Incentives	+57%	Increased budget to finish existing projects and gap-fill for new third-party programs.
PGE21031	Agricultural Calculated Incentives	+173%	Increased budget to finish existing projects and gap-fill for new third-party programs.
PGE21063	Technology Introduction Support	+123%	Introducing new program activities for heat pump water heater replacement, including fuel substitution measures. <sup>(b)</sup>
PGE210911	On-Bill Financing Alternative Pathway	+408%	Transitioning majority of OBF projects (and OBF administration) to the Alternative Pathway model.

(a) PGE\_Res\_001a, PGE\_Res\_001b, PGE\_Res\_001c, and PGE\_Res\_001d are new Program IDs for the four Pay for Performance implementers of the Pay for Performance program activities for 2021 that were previously forecasted and reported through 2020 under Program ID PGE210010. See the "Program ID Changes Resulting from Program ID Reorganization" section and accompanying Table 12 below for more details. The % budget change for PGE\_Res\_001a, PGE\_Res\_001b, PGE\_Res\_001c, and PGE\_Res\_001d is based on the total 2021 program budgets for these four new Program IDs compared to the 2020 program budget for Pay for Performance (PGE210010).

(b) Cost recovery for the fuel substitution portion of this program is discussed in Section III.J. of this advice letter.

### New Programs Launching in 2021

PG&E is introducing multiple new programs into its 2021 portfolio as a result of its third-party local and statewide solicitations processes (and the statewide solicitations of other lead PAs, in cases where PG&E is not the lead PA). There is a total of 25 new programs in 2021:

- Eight new local, third-party resource programs;
- Eight new government partnership non-resource programs; and

- Nine new statewide programs.<sup>50</sup>

These new programs are listed in Table 10 below. Some of these programs will incur expenditures to be reported in 2020 as a result of implementation plan development upon finalization of the new program contracts. Attachment 4, Table 8 of this advice letter details the SW program budgets by IOU for 2021.

**Table 10: New Local Third-Party, Government Partnership, and Statewide Programs for 2021 Portfolio**

Program ID	Program Name	Program Type
PGE_Ag_001	Agriculture Energy Savings Action Plan	Local Third-Party
PGE_Com_001	Grocery Comprehensive Retrofit & Commissioning	Local Third-Party
PGE_Com_002	Smart Labs	Local Third-Party
PGE_Ind_002	Business Energy Performance Program	Local Third-Party
PGE_Ind_003	Industrial Systems Optimization Program	Local Third-Party
PGE_Pub_009	Government & K-12 Comprehensive Program	Local Third-Party
PGE_Pub_010	RAPIDS Wastewater Treatment Optimization Program	Local Third-Party
PGE_Res_003	Multifamily Energy Savings Program	Local Third-Party
PGE_Pub_001	Central Coast Leaders in Energy Action Program	Government Partnership
PGE_Pub_002	Marin Energy Watch Partnership	Government Partnership
PGE_Pub_003	Redwood Coast Energy Watch	Government Partnership
PGE_Pub_004	Central California Energy Watch	Government Partnership
PGE_Pub_005	San Mateo County Energy Watch Program	Government Partnership
PGE_Pub_006	Energy Access SF	Government Partnership
PGE_Pub_007	Sierra Nevada Energy Watch	Government Partnership
PGE_Pub_008	Sonoma Public Energy	Government Partnership
PGE_SW_FS	Food Service POS	Statewide
PGE_SW_UL	Lighting (Upstream)	Statewide

<sup>50</sup> While PG&E's 2021 forecast includes fourteen statewide Program IDs in 2021, only nine are listed in Table 10 because the remaining five 2021 SW programs were included in PG&E's 2020 ABAL, and thus are shown in Table 9 for program budget changes relative to 2020. The five SW programs introduced in 2020 and continuing in 2021 are the SW Non-Residential New Construction program (PGE\_SW\_NC\_NonRes), the SW Residential New Construction program (PGE\_SW\_NC\_Res), and the SW Codes and Standards Advocacy programs for Appliance, State Building, and National codes (PGE\_SW\_CSA\_App, PGE\_SW\_CSA\_Bldg, and PGE\_SW\_CSA\_Natl, respectively). Each statewide program also includes a second Program ID in CEDARS to capture PG&E's administrative costs to support the statewide program. These additional Program IDs are not shown in Tables 9 (no significant budget changes relative to 2020) or Table 10.



PGE_SW_MCWH	Midstream Comm Water Heating	Statewide
PGE_SW_ETP_Gas	Emerging Technologies Program, Gas	Statewide
PGE_SW_PLA	Plug Load and Appliance	Statewide
PGE_SW_HVAC_Up	Upstream HVAC (Comm + Res)	Statewide
PGE_SW_WET_K12	WE&T K-12 Connections	Statewide
PGE_SW_WET_WORK	WE&T Career and Workforce Readiness	Statewide
PGE_SW_IP_Gov	Institutional Partnerships: Department of General Services and Department of Corrections and Rehabilitation	Statewide

### Program ID Changes Resulting from Program ID Reorganization

PG&E is deactivating two of its Program IDs on CEDARS as program activities are transferred under existing Program IDs to remove duplicative program offerings between Programs, as shown in Table 11 below. The program activities under the Program IDs that are being deactivated will not be ceasing, therefore the program activities are not classified as “closed” at this point in time; rather, these program activities will be continuing but consolidated under another existing Program ID to ensure consolidated and coordinated program activities.

**Table 11: 2020 Program IDs Deactivated as Program Activities Move to Alternative Existing Program ID**

2020 ABAL		2021 ABAL	
Program ID	Program Name	Program ID Acquiring Program Activities	Program Name Acquiring Program Activities
PGE21004	Energy Upgrade California	PGE_Res_001a	Pay for Performance – Comfortable Home Rebates
PGE21006	Residential HVAC		

As PG&E moves towards a largely outsourced portfolio, it seeks to align the Program IDs in CEDARS with individual program implementers to enable more transparent program performance management for implementers. To this end, PG&E is splitting up three of its 2020 existing Program IDs into multiple Program IDs as shown in Table 12 below. The 2020 Residential Pay for Performance program (historically PGE210010) has been split into four separate Program IDs for its 2021 forecast, for each of its unique residential Pay for Performance implementers. Similarly, PG&E has split up its 2020 Industrial Strategic Energy Management program (historically PGE21030) into two separate Program IDs for its 2021 forecast for each implementer. Lastly, PG&E has split up its 2020 Residential Energy Advisor program into three separate Program IDs for its 2021 forecast for each distinct program offering.

**Table 12: 2020 Program IDs Split into Multiple 2021 Program IDs**

2020 ABAL		2021 ABAL	
Program ID	Program Name	Program ID	Program Name
PGE210010	Residential Pay for Performance Pilot	PGE_Res_001a	Pay for Performance – Comfortable Home Rebates
		PGE_Res_001b	Pay for Performance – Home Intel
		PGE_Res_001c	Pay for Performance – Home Energy Rewards
		PGE_Res_001d	Pay for Performance – Home Energy Optimization
PGE21030	Industrial Strategic Energy Management	PGE_Ind_001a	Industrial Strategic Energy Management - Food Processing
		PGE_Ind_001b	Industrial Strategic Energy Management - Manufacturing
PGE21001	Residential Energy Advisor	PGE_Res_002a	Residential Energy Advisor – Home Energy Check-Ups
		PGE_Res_002b	Residential Energy Advisor - Marketplace
		PGE_Res_002c	Residential Energy Advisor – Home Energy Reports

## H. EM&V

PG&E proposes a PG&E EM&V budget of \$9,508,971, consistent with the 4% EM&V budget cap originally adopted in D.09-09-047 and upheld in subsequent EE budget Decisions.<sup>51</sup> D.16-08-019 established grounds to revise the allocation of EM&V fund split between Commission and IOU EM&V efforts, beginning after the EE Business Plans are approved by the Commission, to at least 60% reserved for Commission staff evaluation efforts and up to 40% for PAs.<sup>52</sup> The default allocation is 72.5% of EM&V funds for Commission EM&V efforts and 27.5% for PG&E EM&V efforts. PG&E's 2021 EM&V forecast includes a shift of \$275,000 in estimated costs for eTRM maintenance and administration from the CPUC EM&V portion to PG&E's PA EM&V portion, bringing the EM&V allocation to 69.6% CPUC / 30.4% PG&E PA.<sup>53</sup> Table 13 presents the EM&V allocations for PG&E, BayREN, MCE, and 3C-REN using the REN and MCE 2021 budgets presented in their CAEECC presentations on August 5, 2020.

<sup>51</sup> D.10-04-029, D.12-05-015, D.14-10-046, D.15-10-028, D.16-08-019.

<sup>52</sup> D.16-08-019, OP 16.

<sup>53</sup> Draft 2022 DEER Resolution E-5082, p.10 directs the IOUs to include eTRM administration and maintenance costs in their 2021 ABALs. A joint call with the IOUs and Amy Reardon on April 7, 2020 introduced the plan to leverage EM&V funds for these expenses, and verbal approval was received from Energy Division staff to proceed with this plan and reallocate a share of CPUC EM&V funds to the IOU to cover this eTRM work.

**Table 13: 2020 EM&V Budget**

PA	Total PA Budget without EM&V	EM&V Total <sup>(a)</sup>	EM&V CPUC Portion <sup>(b)</sup>	EM&V PA Portion	Total PA Budget with EM&V
PG&E <sup>(c)</sup>	\$228,215,304	\$9,508,971	\$6,619,004	\$2,889,967	\$237,724,275
BayREN <sup>(d)</sup>	\$23,911,548	\$996,315	\$736,250	\$260,065	\$24,907,863
MCE <sup>(e)</sup>	\$7,527,318	\$313,638	\$193,201	\$120,437	\$7,840,956
3C-REN <sup>(f)</sup>	\$3,920,942	\$163,373	\$129,760	\$33,612	\$4,084,315

(a) The EM&V total amount (including CPUC and PA portions) is assumed to be 4% of the PA's total budget with EM&V.

(b) For BayREN, MCE, and 3C-REN, the EM&V CPUC portion was calculated by subtracting the PA's portion from the EM&V total.

(c) Assumes a total PG&E EM&V split of 69.6% CPUC / 30.4% PA. PG&E shifted \$275,000 in EM&V budget from the CPUC share of the default 72.5% CPUC / 27.5% PG&E split of the total EM&V budget to the PG&E share to cover anticipated eTRM enhancement costs in 2021, in alignment with Draft 2022 DEER Resolution E-5082, p.10 and conversations with Energy Division Staff in Q2 2020.

(d) BayREN total budget without EM&V and EM&V PA portion taken from BayREN 2021 ABAL CAEECC Presentation on August 5, 2020.

(e) MCE total budget without EM&V and EM&V PA portion taken from MCE 2021 ABAL CAEECC Presentation on August 5, 2020.

(f) 3C-REN total budget without EM&V and EM&V PA portion taken from 3C-REN 2021 ABAL CAEECC Presentation on August 5, 2020. PG&E's portion of 3C-REN's budget is 45.6%.

## I. Unspent Funds

### 1. PG&E Prior Years' Unspent Funds

Table 14 illustrates PG&E's unspent funds for prior years' program cycles.<sup>54</sup> This data is also presented in the Appendices on Table 6: Committed Energy Efficiency Program Funding Not Yet Spent, and Table 7: 2020 Authorized and Spent/Unspent Detail. As of June 2020, PG&E estimates that \$10 million of funds are unspent and uncommitted. The 2021 EE revenue collections will be offset by 2020 unspent and uncommitted funds to be finalized in early 2021 when 2020 program year activities conclude.

PG&E submitted a Tier 1 Advice Letter 4298-G/5926-E on August 24, 2020 summarizing the remaining balance of unspent and uncommitted funds from Program Year 2019 to be returned at the soonest rate filing opportunity. The Commission's non-standard disposition of PG&E's 2020 ABAL, issued on December 24, 2019, approved the return of an estimated \$13,324,000 in unspent and uncommitted 2019 funds.<sup>55</sup> However, after this disposition was received and 2019 program year expenditures were finalized, PG&E determined there was a remaining balance of \$7,674,475 in 2019 unspent and uncommitted funds to be returned. These remaining funds will be returned at the soonest

<sup>54</sup> Table 8 reflects balances through June 2020.

<sup>55</sup> Non-standard disposition to Advice 4136-G/5627-E and Advice 4136-G-A/5627-E-A, dated December 20, 2019 and issued on December 24, 2019.

opportunity; the Tier 1 advice letter is assumed to be effective as of August 24, 2020, the date of the advice letter submission.

**Table 14: Prior Years' Unspent Funds as of June 2020**

	PY2013-2015	PY 2016	PY 2017	PY 2018	PY 2019	PY 2020 (estimated)	Totals
<b>Unspent &amp; Committed</b>							
EM&V <sup>(a)</sup>	\$3,168,896	\$15,672,827	\$14,479,143	\$11,501,157	\$0	\$7,837,885	\$52,659,907
Financing Pilots <sup>(b)</sup>	\$123,025	\$0	\$165,400	\$220,797	\$500,000	\$500,000	\$1,509,222
BayREN	\$3,760,885	\$0	\$42,769	\$5,218,732	\$2,989,987	\$11,161,983	\$23,174,356
MCE	\$36,182	\$104,615	\$0	\$223,670	-\$56,956	\$5,370,600	\$5,678,111
3C REN	\$0	\$0	\$0	\$0	\$2,420,453	\$1,890,093	\$4,310,546
<b>Total</b>	<b>\$7,088,987</b>	<b>\$15,777,442</b>	<b>\$14,687,312</b>	<b>\$17,164,356</b>	<b>\$5,853,483</b>	<b>\$26,760,561</b>	<b>\$87,332,142</b>
<b>Estimated Unspent &amp; Uncommitted for 2021 Offset</b>							
Utility Program Funds	\$0	\$0	\$0	\$0	\$0	\$10,000,000	\$10,000,000

(a) Includes unspent funds from the CPUC (\$41.7 million) and PG&E (\$11.0 million)

(b) 2017, 2018, 2019, and 2020 committed funds were authorized in AL 3904-G/5175-E, approved effective December 3, 2017.

## 2. PG&E's MCE Sub-Account Prior Years' Unspent Funds

In D.14-10-046, the Commission instructed PG&E to offset MCE's unspent funds against payments to be made to MCE under its authorized electric EE portfolio budget. As of July 31, 2020, PG&E estimates that all of MCE's 2020 electric funds (authorized in ABAL 37-E) will be paid to MCE by the end of 2020.

## J. Cost Recovery

### 1. EE Budget Cost Recovery

The PG&E energy efficiency budget for 2021 cost recovery purposes upon approval of this advice letter is \$227,724,275,<sup>56</sup> which includes the estimated unspent and uncommitted carryover balance for program year 2020 discussed in Section III.I.1. The energy-efficiency budgets for PG&E's 2021 cost recovery related to MCE, BayREN, and 3C-REN will be based upon Commission approval of the budgets they present in their 2021 ABALs, including the CPUC portion of the REN and CCA EM&V budgets. PG&E

<sup>56</sup> Revenue Fees and Uncollectible Account Expenses (RF&U) are not included in this cost recovery budget but will be added to electric funding to determine the revenue requirement when recovered in rates through the Annual Electric True-up (AET). This cost recovery budget includes benefits burdens.

will collect from customers the combined total of PG&E, MCE, BayREN, and 3C-REN's cost recovery budgets. PG&E is not requesting cost recovery budget for RCEA because it is funding RCEA's 2021 program using unspent and uncommitted funds from its 2020 program year budget.<sup>57</sup>

The allocation of the authorized 2021 budget for electric and gas cost recovery will be based on the electric/gas split attributed to the most recent Commission-approved program forecast.<sup>58</sup> If the Commission approves the electric/gas split of 83%/17% associated with the 2021 EE program forecast in this advice letter, PG&E will apply this electric/gas split for 2021 cost recovery purposes. If the Commission does not approve the electric/gas split associated with the 2021 EE program forecast in this advice letter, PG&E will default to its last approved electric/gas split of 70%/30% from the 2020 ABAL.<sup>59</sup>

PG&E's electric and gas cost recovery requests reflect direction by D.19-08-009 OP 5 for PG&E to fund fuel substitution measures via ratepayers of the new fuel and not the fuel being substituted. PG&E's Emerging Technologies Subprogram Technology Introduction Support (PGE21063) will, among other program activities, be exploring heat pump water heater fuel substitution measures.<sup>60</sup> Of the total Technology Introduction Support program budget, PG&E expects approximately \$877,602 to support fuel substitution activities and will ensure this budget is included in the portion of costs recovered via electric rates.

**Table 15: PG&E 2021 EE Portfolio Cost Recovery Summary**

Cost Recovery Component	Total Amount	Applicable Electric/Gas Split <sup>(a)</sup>		Electric Portion for Cost Recovery	Gas Portion for Cost Recovery
		Electric	Gas		
PG&E Total 2021 EE Portfolio Budget (Less Fuel Substitution Budget)	\$236,846,673	83%	17%	\$196,582,739	\$40,263,934
Estimated 2020 Unspent and Uncommitted Funds	-\$10,000,000	70%	30%	-\$7,000,000	-\$3,000,000
2021 Budget Forecasted to Support Fuel Substitution <sup>(b)</sup>	\$877,602	100%	0%	\$877,602	\$0

<sup>57</sup> RCEA 2021 budget recovery request is set at \$0. PG&E transferred funds from its 2020 budget to RCEA for the full 3-year program amount approved via Resolution E-5050, as directed by the Resolution. No further cost recovery for RCEA is required at this time.

<sup>58</sup> The electric/gas split will be applied to the portion of the 2021 EE portfolio budget not attributed to support fuel-substitution measures as shown in Table 15. The EE portfolio costs to support fuel-substitution program activities will be recovered through electric rates only.

<sup>59</sup> Advice 4136-G/5627-E filed September 3, 2020, and Advice 4136-G-A/5627-E-A, filed November 15, 2019. Non-standard disposition of Advice 4136-G/5627-E and Advice 4136-G-A/5627-E-A dated December 20, 2019 and issued on December 24, 2019.

<sup>60</sup> See Section III.G. of this advice letter.

Total	\$227,724,275		\$190,460,341	\$37,263,934
-------	---------------	--	---------------	--------------

(a) The 2021 electric/gas split is forecasted to be 83%/17%. The 2020 electric/gas split of 70%/30% was approved via non-standard disposition to Advice 4136-G/5627-E and Advice 4136-G-A/5627-E-A, dated December 20, 2019 and issued on December 24, 2019.

(b) Fuel substitution measures as part of the Technology Introduction Support program (PGE21063) are discussed in Table 9, Section III.G. of this advice letter.

## 2. Integrated Demand-Side Management (IDSM) Budget

D.18-05-041 directs each IOU PA to set aside a minimum of \$1 million for the residential sector and a load-share-proportional fraction of \$20 million for the commercial sector from each IOU PA's IDSM budget for testing and deployment of integration strategies.<sup>61</sup> In consultation and agreement with the IOUs, PG&E will budget \$8 million of the required \$20 million for the commercial sector. With an additional \$1 million of IDSM budget for the residential sector, PG&E's budget for IDSM activities will total \$9 million.

**Table 16: Demand Response IDSM Funding Request in 2021 Rates**

Category	PG&E Electric Demand Response Funds <sup>62</sup>
Energy Efficiency	\$1,000,000
Demand Response	\$8,000,000
<b>Total PG&amp;E</b>	<b>\$9,000,000</b>

Regarding IDSM funding, RF&U is not included in this table but will be added to electric funding to determine the revenue requirement when recovered in rates through the AET.

Of PG&E's \$9 million IDSM budget, \$1 million will be allocated to the EE portion of the IDSM budget, and \$8 million will be allocated to the Demand Response portion of the IDSM budget. The \$1 million EE portion of the budget is embedded within the residential and ET sector budgets shown in Table 1. The \$8 million IDSM budget related to Demand Response will continue to be tracked in the Demand Response Expense Balancing Accounting and recovered via the Distribution Revenue Adjustment Mechanism.

## K. Metrics

Pursuant to D.18-05-041, PG&E reported on sector-level metrics and their associated targets for program years 2017, 2018, and 2019 as part of the 2017, 2018, and 2019 EE

<sup>61</sup> D.18-05-041, OP 10.

<sup>62</sup> Administrative Law Judge's Ruling Providing Guidance for the 2012-2014 Demand Response Applications, Rulemaking (R.) 07-01-041, August 27, 2010 directed that future authority and funding for the demand response portion of the Integrated Design-Side Management activities be considered in EE proceedings starting with the EE applications for 2013-2015. These funds were approved in D.18-05-041, OP 10.

Annual Report filings filed on May 1, 2018, May 1, 2019, and May 1, 2020, respectively. They can be found in spreadsheet form on the CPUC's data reporting website, Energy Efficiency Statistics (EEStats),<sup>63</sup> by filtering documents for the "Annual" Report Category and "Narrative & Spreadsheet" Report Type.

### **Protests**

**\*\*\*Due to the COVID-19 pandemic and the shelter at home orders, PG&E is currently unable to receive protests or comments to this advice letter via U.S. mail or fax. Please submit protests or comments to this advice letter to EDTariffUnit@cpuc.ca.gov and PGETariffs@pge.com\*\*\***

Anyone wishing to protest this submittal may do so by letter sent via U.S. mail, facsimile or E-mail, no later than September 21, 2020, which is 20 days after the date of this submittal. Protests must be submitted to:

CPUC Energy Division  
ED Tariff Unit  
505 Van Ness Avenue, 4<sup>th</sup> Floor  
San Francisco, California 94102

Facsimile: (415) 703-2200  
E-mail: EDTariffUnit@cpuc.ca.gov

Copies of protests also should be mailed to the attention of the Director, Energy Division, Room 4004, at the address shown above.

The protest shall also be sent to PG&E either via e-mail or U.S. mail (and by facsimile, if possible) at the address shown below on the same date it is mailed or delivered to the Commission:

Erik Jacobson  
Director, Regulatory Relations  
c/o Megan Lawson  
Pacific Gas and Electric Company  
77 Beale Street, Mail Code B13U  
P.O. Box 770000  
San Francisco, California 94177

Facsimile: (415) 973-3582  
E-mail: PGETariffs@pge.com

---

<sup>63</sup> <http://eestats.cpuc.ca.gov/Views/Documents.aspx>

Any person (including individuals, groups, or organizations) may protest or respond to an advice letter (General Order 96-B, Section 7.4). The protest shall contain the following information: specification of the advice letter protested; grounds for the protest; supporting factual information or legal argument; name, telephone number, postal address, and (where appropriate) e-mail address of the protestant; and statement that the protest was sent to the utility no later than the day on which the protest was submitted to the reviewing Industry Division (General Order 96-B, Section 3.11).

### **Effective Date**

PG&E requests that the Commission approve its 2021 spending budget of \$237,724,275 and its 2021 cost recovery budget of \$227,724,275 through a non-standard disposition effective January 1, 2021. PG&E additionally requests that the Commission approve the forecasted 2021 electric/gas split 83%/17% associated with its 2021 EE program forecast for non-fuel-substitution cost recovery budget allocations effective January 1, 2021. This will allow PG&E to recover gas and electric costs in amounts that more appropriately match the new measure potential in 2021.<sup>64</sup>

### **Notice**

In accordance with General Order 96-B, Section IV, a copy of this advice letter is being sent electronically and via U.S. mail to parties shown on the attached list and the parties on the service lists for R.13-11-005, A.17-01-013 et al. Address changes to the General Order 96-B service list should be directed to PG&E at email address PGETariffs@pge.com. For changes to any other service list, please contact the Commission's Process Office at (415) 703-2021 or at Process\_Office@cpuc.ca.gov. Send all electronic approvals to PGETariffs@pge.com. Advice letter submittals can also be accessed electronically at: <http://www.pge.com/tariffs/>.

\_\_\_\_\_  
/S/

Erik Jacobson  
Director, Regulatory Relations

### **Attachments:**

- Attachment 1 – California Energy Data and Reporting System (CEDARS) Filing Confirmation
- Attachment 2 – Program Changes Table
- Attachment 3 – Supplemental Budget Tables
- Attachment 4 – Appendices

---

<sup>64</sup> The 2021 ABAL forecasted electric/gas split is 83%/17%, excluding fuel-substitution program budget, compared with the 70%/30% electric/gas split approved in the 2020 ABAL that is the basis of cost recovery budget allocation in 2020.



cc: Peter Franzese, Energy Division  
Service List R.13-11-005  
Service List A.17-01-013 et al.



# ADVICE LETTER SUMMARY

## ENERGY UTILITY



MUST BE COMPLETED BY UTILITY (Attach additional pages as needed)

Company name/CPUC Utility No.: Pacific Gas and Electric Company (ID U39M)

Utility type:

- ELC       GAS       WATER  
 PLC       HEAT

Contact Person: Kimberly Loo

Phone #: (415)973-4587

E-mail: PGETariffs@pge.com

E-mail Disposition Notice to: KELM@pge.com

### EXPLANATION OF UTILITY TYPE

ELC = Electric      GAS = Gas      WATER = Water  
 PLC = Pipeline      HEAT = Heat

(Date Submitted / Received Stamp by CPUC)

Advice Letter (AL) #: 4303-G/5936-E

Tier Designation: 2

Subject of AL: PG&E's 2021 Energy Efficiency Annual Budget Advice Letter in Compliance with Decisions 15-10-028 and 18-05-041

Keywords (choose from CPUC listing): Compliance, Energy Efficiency

AL Type:  Monthly  Quarterly  Annual  One-Time  Other:

If AL submitted in compliance with a Commission order, indicate relevant Decision/Resolution #: D.15-10-028 and D.18-05-041

Does AL replace a withdrawn or rejected AL? If so, identify the prior AL: No

Summarize differences between the AL and the prior withdrawn or rejected AL:

Confidential treatment requested?  Yes  No

If yes, specification of confidential information:

Confidential information will be made available to appropriate parties who execute a nondisclosure agreement. Name and contact information to request nondisclosure agreement/ access to confidential information:

Resolution required?  Yes  No

Requested effective date: 1/1/21

No. of tariff sheets: 0

Estimated system annual revenue effect (%): N/A

Estimated system average rate effect (%): N/A

When rates are affected by AL, include attachment in AL showing average rate effects on customer classes (residential, small commercial, large C/I, agricultural, lighting).

Tariff schedules affected: N/A

Service affected and changes proposed<sup>1</sup>: N/A

Pending advice letters that revise the same tariff sheets: N/A

<sup>1</sup>Discuss in AL if more space is needed.

**Protests and all other correspondence regarding this AL are due no later than 20 days after the date of this submittal, unless otherwise authorized by the Commission, and shall be sent to:**

CPUC, Energy Division  
Attention: Tariff Unit  
505 Van Ness Avenue  
San Francisco, CA 94102  
Email: [EDTariffUnit@cpuc.ca.gov](mailto:EDTariffUnit@cpuc.ca.gov)

Name: Erik Jacobson, c/o Megan Lawson  
Title: Director, Regulatory Relations  
Utility Name: Pacific Gas and Electric Company  
Address: 77 Beale Street, Mail Code B13U  
City: San Francisco, CA 94177  
State: California Zip: 94177  
Telephone (xxx) xxx-xxxx: (415)973-2093  
Facsimile (xxx) xxx-xxxx: (415)973-3582  
Email: [PGETariffs@pge.com](mailto:PGETariffs@pge.com)

Name:  
Title:  
Utility Name:  
Address:  
City:  
State: District of Columbia Zip:  
Telephone (xxx) xxx-xxxx:  
Facsimile (xxx) xxx-xxxx:  
Email:

## **Attachment 1**

**California Energy Data and Reporting System (CEDARS)  
Filing Confirmation**

PGE 2021 ABAL  
Attachment 1 – CEDARS Filing Receipt

CEDARS FILING SUBMISSION RECEIPT

The PGE portfolio filing has been submitted and is now under review. A summary of the filing is provided below.

PA: Pacific Gas & Electric (PGE)

Filing Year: 2021

Submitted: 23:59:51 on 31 Aug 2020

By: Wilson Wong

Advice Letter Number: 4303-G/5936-E

\* Portfolio Filing Summary \*

- TRC: 1.9084
- PAC: 6.3843
- TRC (no admin): 2.4915
- PAC (no admin): 29.424
- RIM: 0.6618
- Budget: \$220,724,275.20

\* Programs Included in the Filing \*

- PGE21002: Residential Energy Efficiency
- PGE21005: Residential New Construction
- PGE21007: California New Homes Multifamily
- PGE21011: Commercial Calculated Incentives
- PGE21012: Commercial Deemed Incentives
- PGE21014: Commercial Energy Advisor
- PGE210143: Hospitality Program
- PGE21021: Industrial Calculated Incentives
- PGE210210: Industrial Recommissioning Program
- PGE210212: Compressed Air and Vacuum Optimization Program
- PGE21022: Industrial Deemed Incentives
- PGE21024: Industrial Energy Advisor
- PGE21027: Heavy Industry Energy Efficiency Program
- PGE21031: Agricultural Calculated Incentives
- PGE21032: Agricultural Deemed Incentives
- PGE21034: Agricultural Energy Advisor
- PGE21036: Industrial Refrigeration Performance Plus
- PGE21053: Compliance Improvement
- PGE21054: Reach Codes
- PGE21055: Planning and Coordination

PGE 2021 ABAL

Attachment 1 – CEDARS Filing Receipt

- PGE21056: Code Readiness
- PGE21062: Technology Assessments
- PGE21063: Technology Introduction Support
- PGE21071: Integrated Energy Education and Training
- PGE21072: Connections
- PGE21091: On-Bill Financing (excludes Loan Pool)
- PGE210911: On-Bill Financing Alternative Pathway
- PGE21091LP: Financing Loan Pool Addition
- PGE2110011: California Community Colleges
- PGE2110012: University of California/California State University
- PGE2110013: State of California
- PGE2110014: Department of Corrections and Rehabilitation
- PGE2110051: Local Government Energy Action Resources (LGEAR)
- PGE211025: Savings by Design (SBD)
- PGE\_3P\_Com: New 3P Placeholder - Commercial
- PGE\_3P\_Res: New 3P Placeholder - Residential
- PGE\_Ag\_001: Agriculture Energy Savings Action Plan
- PGE\_Com\_001: Grocery Comprehensive Retrofit and Commissioning
- PGE\_Com\_002: Smart Labs
- PGE\_EMV: Evaluation Measurement and Verification
- PGE\_ESA: Energy Savings Assistance
- PGE\_ESPI: Energy Savings Performance Index
- PGE\_Ind\_001a: Industrial Strategic Energy Management - Food Processing
- PGE\_Ind\_001b: Industrial Strategic Energy Management - Manufacturing
- PGE\_Ind\_002: Business Energy Performance Program
- PGE\_Ind\_003: Industrial Systems Optimization Program
- PGE\_Pub\_001: Central Coast Leaders in Energy Action Program
- PGE\_Pub\_002: Marin Energy Watch Partnership
- PGE\_Pub\_003: Redwood Coast Energy Watch
- PGE\_Pub\_004: Central California Energy Watch
- PGE\_Pub\_005: San Mateo County Energy Watch Program
- PGE\_Pub\_006: Energy Access SF
- PGE\_Pub\_007: Sierra Nevada Energy Watch
- PGE\_Pub\_008: Sonoma Public Energy
- PGE\_Pub\_009: Government and K-12 Comprehensive Program
- PGE\_Pub\_010: RAPIDS Wastewater Treatment Optimization Program
- PGE\_Res\_001a: Pay for Performance - Comfortable Home Rebates
- PGE\_Res\_001b: Pay for Performance - Home Intel
- PGE\_Res\_001c: Pay for Performance - Home Energy Rewards
- PGE\_Res\_001d: Pay for Performance - Home Energy Optimization
- PGE\_Res\_002a: Residential Energy Advisor - Home Energy Checkups
- PGE\_Res\_002b: Residential Energy Advisor - Marketplace
- PGE\_Res\_002c: Residential Energy Advisor - Home Energy Reports
- PGE\_Res\_003: Multifamily Energy Savings Program
- PGE\_SW\_CSA\_App: State Appliance Standards Advocacy
- PGE\_SW\_CSA\_App\_PA: State Appliance Standards Advocacy PA Costs

PGE 2021 ABAL

Attachment 1 – CEDARS Filing Receipt

- PGE\_SW\_CSA\_Bldg: State Building Codes Advocacy
- PGE\_SW\_CSA\_Bldg\_PA: State Building Codes Advocacy PA Costs
- PGE\_SW\_CSA\_Natl: National Codes & Standards Advocacy
- PGE\_SW\_CSA\_Natl\_PA: National Codes & Standards Advocacy PA Costs
- PGE\_SW\_ETP\_Gas: Emerging Technologies Program, Gas
- PGE\_SW\_ETP\_Gas\_PA: Emerging Technologies Program, Gas - PGE Costs
- PGE\_SW\_FS: Food Service POS
- PGE\_SW\_FS\_PA: Food Service POS - PGE Costs
- PGE\_SW\_HVAC\_Up: Upstream HVAC (Comm and Res)
- PGE\_SW\_HVAC\_Up\_PA: Upstream HVAC (Comm and Res) - PGE Costs
- PGE\_SW\_IP\_Gov: Institutional Partnerships: DGS and DoC
- PGE\_SW\_IP\_Gov\_PA: Institutional Partnerships: DGS and DoC - PGE Costs
- PGE\_SW\_MCWH: Midstream Comm Water Heating
- PGE\_SW\_MCWH\_PA: Midstream Comm Water Heating - PGE Costs
- PGE\_SW\_MEO: Statewide Marketing Education and Outreach
- PGE\_SW\_NC\_NonRes: New Construction Non-Residential
- PGE\_SW\_NC\_NonRes\_PA: New Construction Non-Residential - PGE Costs
- PGE\_SW\_NC\_Res: New Construction Residential
- PGE\_SW\_NC\_Res\_PA: New Construction Residential - PGE Costs
- PGE\_SW\_PLA: Plug Load and Appliance
- PGE\_SW\_PLA\_PA: Plug Load and Appliance - PGE Costs
- PGE\_SW\_UL: Lighting (Upstream)
- PGE\_SW\_UL\_PA: Lighting (Upstream) - PGE Costs
- PGE\_SW\_WET\_CC: WET Career Connections
- PGE\_SW\_WET\_CC\_PA: WET Career Connections - PGE Costs
- PGE\_SW\_WET\_Work: WET Career and Workforce Readiness
- PGE\_SW\_WET\_Work\_PA: WET Career and Workforce Readiness - PGE Costs

## **Attachment 2**

### **Program Changes Table**



PG&E 2021 EE ABAL Attachment 2 – Program Changes Tables

**Programs to be closed with the disposition of 2021 ABAL**

Program ID	Program Name	Third-Party Implementer or Core	Statewide or Local	PA justification <sup>(a)</sup>	% change	2020 Claimed TRC	2021 Filed TRC <sup>(b)</sup>	2021 ABAL Budget	2020 ABAL Budget	Year program started <sup>(c)</sup>	For existing third party implemented programs, MM/YY Program was due to sunset prior to PY 2021 ABAL planning and new 3P contracting <sup>(d)</sup>	For existing third party implemented programs, MM/YY Program is extended to as a result of PY 2021 ABAL planning and timing for new 3P contracts' ramp up <sup>(d)</sup>
PGE21008	Enhance Time Delay Relay	Third-Party	Local	Will be replaced by incoming 3P program.	n/a	0.44	n/a	\$0	\$872,822	2013	12/2020	n/a
PGE210011	Residential Energy Fitness Program	Third-Party	Local	Will be replaced by incoming 3P program.	n/a	0.00	n/a	\$0	\$6,529,042	2016	12/2020	n/a
PGE21003	Multifamily Energy Efficiency Program	Core	Local	Will be replaced by incoming 3P program.	n/a	0.52	n/a	\$0	\$4,651,856	2013	12/2020	n/a
PGE21009	Direct Install for Manufactured and Mobile Homes	Third-Party	Local	Closed as a result of portfolio balancing.	n/a	0.46	n/a	\$0	\$813,165	2013	12/2020	n/a
PGE210112	School Energy Efficiency	Third-Party	Local	Will be replaced by incoming 3P program.	n/a	0.36	n/a	\$0	\$1,292,461	2013	12/2020	n/a
PGE210123	Healthcare Energy Efficiency Program	Third-Party	Local	Will be replaced by incoming 3P program.	n/a	0.00	n/a	\$0	\$994,021	2013	12/2020	n/a
PGE210135	Water Infrastructure and System Efficiency (WISE)	Third-Party	Local	Will be replaced by incoming 3P program.	n/a	0.00	n/a	\$0	\$1,301,793	2014	12/2020	n/a
PGE21015	Commercial HVAC	Core	Local	Will be replaced by incoming 3P program.	n/a	0.23	n/a	\$0	\$6,044,854	2013	12/2020	n/a
PGE21018	EnergySmart Grocer Program	Third-Party	Local	Will be replaced by incoming 3P program.	n/a	0.33	n/a	\$0	\$6,176,529	2013	12/2020	n/a
PGE21026	Energy Efficiency Services for Oil Production	Third-Party	Local	Will be replaced by incoming 3P program.	n/a	0.00	n/a	\$0	\$927,077	2013	12/2020	n/a
PGE210311	Process Wastewater Treatment Energy Management Program for Ag Food Processing	Third-Party	Local	Will be replaced by incoming 3P program.	n/a	0.00	n/a	\$0	\$203,931	2013	12/2020	n/a
PGE210312	Dairy and Winery Industry Efficiency Solutions	Third-Party	Local	Will be replaced by incoming 3P program.	n/a	0.33	n/a	\$0	\$1,421,553	2013	12/2020	n/a
PGE21039	Comprehensive Food Process Audit & Resource Efficiency (CFP)	Third-Party	Local	Will be replaced by incoming 3P program.	n/a	0.00	n/a	\$0	\$2,250,083	2013	12/2020	n/a
PGE2110052	Strategic Energy Resources	Third-Party	Local	Will be replaced by incoming 3P LGP programs.	n/a	n/a	n/a	\$0	\$4,961,247	2013	12/2020	n/a
PGE21061	Technology Development Support	Core	Local	Will be replaced by incoming 3P program.	n/a	n/a	n/a	\$0	\$449,065	2013	12/2020	n/a
PGE21076	Career and Workforce Readiness	Core	Statewide	Will be replaced by new 2021 SW program.	n/a	n/a	n/a	\$0	\$131,789	2019	12/2020	n/a
PGE21041	Primary Lighting	Core	Statewide	Will be replaced by new 2021 SW program.	n/a	n/a	n/a	\$0	\$0	2013	12/2019 <sup>(e)</sup>	n/a
PGE21042	Lighting Innovation	Core	Statewide	Will be replaced by new 2021 SW program.	n/a	n/a	n/a	\$0	\$0	2013	12/2019 <sup>(e)</sup>	n/a
PGE21051	Building Codes Advocacy	Core	Statewide	Will be replaced by new 2021 SW program.	n/a	n/a	n/a	\$0	\$0	2013	12/2020	n/a

## PG&E 2021 EE ABAL Attachment 2 – Program Changes Tables

### Programs to be closed with the disposition of 2021 ABAL

Program ID	Program Name	Third-Party Implementer or Core	Statewide or Local	PA justification <sup>(a)</sup>	% change	2020 Claimed TRC	2021 Filed TRC <sup>(b)</sup>	2021 ABAL Budget	2020 ABAL Budget	Year program started <sup>(c)</sup>	For existing third party implemented programs, MM/YY Program was due to sunset prior to PY 2021 ABAL planning and new 3P contracting <sup>(d)</sup>	For existing third party implemented programs, MM/YY Program is extended to as a result of PY 2021 ABAL planning and timing for new 3P contracts' ramp up <sup>(d)</sup>
PGE21052	Appliance Standards Advocacy	Core	Statewide	Will be replaced by new 2021 SW program.	n/a	n/a	n/a	\$0	\$0	2013	12/2020	n/a
PGE21057	National Codes and Standards Advocacy	Core	Statewide	Will be replaced by new 2021 SW program.	n/a	n/a	n/a	\$0	\$0	2013	12/2020	n/a

(a) See advice letter Section III.G, Tables 7 through 12 for more details on program changes justification.

(b) 2021 filed TRC represents reported results through Q1. TRC values are not representative of full-year performance, and are subject to change in future quarters. Any erroneous reporting values will be corrected in future reporting quarters.

(c) 2013 is the earliest program start year in this table because the majority of current Program IDs were introduced in 2013. Some programs may have been present prior to 2013 under a different (or possibly the same) program ID.

(d) In some cases the contract end date is unknown at the month level, in which case months are marked "TBD".

(e) See advice letter Section III.G., Table 6 for more details.

PG&E 2021 EE ABAL Attachment 2 – Program Changes Tables

**Programs to be closed upon completion of commitments**

Program ID	Program Name	Third-Party Implementer or Core	Statewide or Local	PA justification <sup>(a)</sup>	% change	2020 Claimed TRC	2021 Filed TRC <sup>(b)</sup>	2021 ABAL Budget	2020 ABAL Budget	Year program started <sup>(c)</sup>	For existing third party implemented programs, MM/YY Program was due to sunset prior to PY 2021 ABAL planning and new 3P contracting <sup>(d)</sup>	For existing third party implemented programs, MM/YY Program is extended to as a result of PY 2021 ABAL planning and timing for new 3P contracts' ramp up <sup>(d)</sup>
PGE2110051	Local Government Energy Action Resources (LGEAR)	Third-Party	Local	Previous Energy Watch programs, funded through LGEAR, will ramp down and close direct install programs by the end of 2020, but select contracts have been extended into 2021 to gap-fill for incoming third-party programs.	-72%	0.33	0.56	\$3,075,395	\$11,058,317	2013	n/a	09/2021
PGE210210	Industrial Retro-commissioning Program	Third-Party	Local	Finishing existing pipeline and ramping down in anticipation of new third-party program overlap.	6%	0.00	0.53	\$1,505,303	\$1,426,592	2013	n/a	TBD/2021
PGE21036	Industrial Refrigeration Performance Plus	Third-Party	Local	Program has been ramping down since 2019 for closing out project costs, as mentioned in the 2019 and 2020 ABALs and the 2019 Annual Report.	n/a	0.00	0.00	\$25,073	\$0	2013	n/a	TBD/2021
PGE211025	Savings by Design	Core	Local	Finishing existing project pipeline in anticipation of SW replacement program. Program not accepting new applications.	10%	0.67	0.58	\$1,300,904	\$1,178,280	2013	n/a	n/a <sup>(e)</sup>
PGE210143	Hospitality Program	Third-Party	Local	Ramping down in anticipation of new third-party program overlap but continuing in 2021 to support customers during COVID pandemic.	21%	0.46	0.76	\$3,059,266	\$2,529,781	2016	n/a	06/2021
PGE21027	Heavy Industry Energy Efficiency Program	Third-Party	Local	Finishing existing pipeline and ramping down in anticipation of new third-party program overlap.	-66%	0.38	1.19	\$2,762,997	\$8,117,891	2013	n/a	TBD/2021
PGE21092	Third-Party Financing	Core	Local	Contract still in place for management of remaining third-party loan pool, however no 2021 spend expected.	n/a	0.00	n/a	\$0	\$0	2013	n/a	TBD/2021 or TBD/2022
PGE21005	Residential New Construction - California Advanced Homes Program	Core	Local	Ramping down in anticipation of SW replacement program overlap.	-59%	0.21	0.62	\$1,569,420	\$3,849,277	2013	n/a	12/2021
PGE2110011	California Community Colleges	Core	Local	Increased budget to finish large existing projects	73%	0.04	0.47	\$1,234,186	\$712,478	2013	n/a	TBD/2022
PGE2110012	University of California/California State University	Core	Local	Increased budget to finish large existing projects	363%	-0.41	0.46	\$1,883,522	\$406,780	2013	n/a	TBD/2022
PGE2110013	State of California	Core	Local	Increased budget to finish large existing projects	24%	0.00	0.78	624,642	504,005	2013	n/a	TBD/2021
PGE2110014	Department of Corrections and Rehabilitation	Core	Local	Increased budget to finish existing projects.	53%	0.00	1.74	\$807,589	\$527,187	2013	n/a	TBD/2021

(a) See advice letter Section III.G, Tables 7 through 12 for more details on program changes justification.

(b) 2021 filed TRC represents reported results through Q1. TRC values are not representative of full-year performance, and are subject to change in future quarters. Any erroneous reporting values will be corrected in future reporting quarters.

PG&E 2021 EE ABAL Attachment 2 – Program Changes Tables

**Programs to be closed upon completion of commitments**

Program ID	Program Name	Third-Party Implementer or Core	Statewide or Local	PA justification <sup>(a)</sup>	% change	2020 Claimed TRC	2021 Filed TRC <sup>(b)</sup>	2021 ABAL Budget	2020 ABAL Budget	Year program started <sup>(c)</sup>	For existing third party implemented programs, MM/YY Program was due to sunset prior to PY 2021 ABAL planning and new 3P contracting <sup>(d)</sup>	For existing third party implemented programs, MM/YY Program is extended to as a result of PY 2021 ABAL planning and timing for new 3P contracts' ramp up <sup>(d)</sup>
------------	--------------	---------------------------------	--------------------	---------------------------------	----------	------------------	-------------------------------	------------------	------------------	-------------------------------------	---	--

(c) 2013 is the earliest program start year in this table because the majority of current Program IDs were introduced in 2013. Some programs may have been present prior to 2013 under a different (or possibly the same) program ID.

(d) In some cases the contract end date is unknown at the month level, in which case months are marked "TBD".

(e) The savings by design program is not implemented by a third-party contractor, however the program is expected to ramp-down to completion by the end of 2022.

## PG&E 2021 EE ABAL Attachment 2 – Program Changes Tables

### Programs with reduced budgets (>40% budget decrease), to continue in 2021

Program ID	Program Name	Third-Party Implementer or Core	Statewide or Local	PA justification <sup>(a)</sup>	% change	2020 Claimed TRC	2021 Filed TRC <sup>(b)</sup>	2021 ABAL Budget	2020 ABAL Budget	Year program started <sup>(c)</sup>	For existing third party implemented programs, MM/YY Program was due to sunset prior to PY 2021 ABAL planning and new 3P contracting <sup>(d)</sup>	For existing third party implemented programs, MM/YY Program is extended to as a result of PY 2021 ABAL planning and timing for new 3P contracts' ramp up <sup>(d)</sup>
PGE21002	Residential Energy Efficiency	Core	Local	Ramping down due to SW program overlap. Program will operate through the majority of 2021. Future closure for this PG&E-implemented program may be signaled in 2022 ABAL.	-83%	0.26	0.41	\$949,405	\$5,549,380	2013	n/a	n/a
PGE21012	Commercial Deemed Incentives	Core	Local	Ramping down while fulfilling existing project commitments and gap-filling for new third-party programs. Program will operate through duration of 2021. Future closure for this PG&E-implemented program may be signaled in 2022 ABAL.	-54%	1.26	2.51	\$4,091,291	\$8,852,809	2013	n/a	n/a
PGE21034	Agricultural Energy Advisor	Core	Local	The Advanced Pumping Energy Efficiency Program (APEP) component of this subprogram is moving under Integrated Energy Education and Training (PGE21071). Program will operate through duration of 2021. Future closure for this PG&E-implemented program may be signaled in 2022 ABAL.	-88%	0.56	0.00	\$278,369	\$2,326,462	2013	n/a	n/a
PGE21062	Technology Assessments	Core	Local	Ramping down due to overlap with SW programs.	-53%	0.00	N/A	\$1,460,138	\$3,120,821	2013	n/a	n/a

(a) See advice letter Section III.G, Tables 7 through 12 for more details on program changes justification.

(b) 2021 filed TRC represents reported results through Q1. TRC values are not representative of full-year performance, and are subject to change in future quarters. Any erroneous reporting values will be corrected in future reporting quarters.

(c) 2013 is the earliest program start year in this table because the majority of current Program IDs were introduced in 2013. Some programs may have been present prior to 2013 under a different (or possibly the same) program ID.

(d) In some cases the contract end date is unknown at the month level, in which case months are marked "TBD". Contract extension dates for program budgets increasing or decreasing by 40% or more are marked as "n/a" because contracts will be in place at least through the end of 2021.

PG&E 2021 EE ABAL Attachment 2 – Program Changes Tables

Programs with enhanced budgets (>40% budget increase)

Program ID	Program Name	Third-Party Implementer or Core	Statewide or Local	PA justification (a)	% change	2020 Claimed TRC	2021 Filed TRC (b)	2021 ABAL Budget	2020 ABAL Budget	Year program started (c)	For existing third party implemented programs, MM/YY Program was due to sunset prior to PY 2021 ABAL planning and new 3P contracting (d)	For existing third party implemented programs, MM/YY Program is extended to as a result of PY 2021 ABAL planning and timing for new 3P contracts' ramp up (d)
PGE_3P_Com	Third-Party Placeholder – Local Commercial Programs	Third-Party	Local	The placeholder budget for new local third-party commercial programs not yet under contract is higher in 2021 than 2020 because these new programs are expected to be under contract by the end of 2020 and launching in 2021. The budget forecasted for 2020 was lower due to solicitations timing, which ultimately was delayed past the date expected for the 2020 ABAL.	135%	n/a	1.26	\$19,351,551	\$8,241,182	2020	n/a	n/a
PGE_3P_Res	Third-Party Placeholder – Local Residential Programs	Third-Party	Local	The placeholder budget for new local third-party residential programs not yet under contract is higher in 2021 than 2020 because a new residential behavioral program is expected to be under contract by the end of 2020 and launching in 2021. The budget forecasted for 2020 was lower due to solicitations timing, which ultimately was delayed past the date expected for the 2020 ABAL.	74%	n/a	1.11	\$20,731,541	\$7,055,634	2020	n/a	n/a
PGE_SW_CSA_App	State Appliance Standards Advocacy	Core	SW	New statewide program ramping up.	110%	6.84	10.73	\$3,563,071	\$1,693,770	2020	n/a	n/a
PGE_SW_CSA_Bldg	State Building Codes Advocacy	Core	SW	New statewide program ramping up.	55%	1.37	1.72	\$4,236,532	\$2,735,280	2020	n/a	n/a
PGE_SW_CSA_Natl	National Codes & Standards Advocacy	Core	SW	New statewide program ramping up.	40%	1.47	1.99	\$2,194,267	\$1,569,630	2020	n/a	n/a
PGE_SW_NC_NonRes	SW New Construction Non-Residential	Core	SW	New statewide program ramping up.	57%	0.00	0.36	\$1,195,802	\$760,000	2020	n/a	n/a
PGE_SW_NC_Res	SW New Construction Residential	Core	SW	New statewide program ramping up. Low 2020 budget forecasted in 2020 (\$456k) due to anticipated start in late 2020, however new program launch delayed to 2021, resulting in large 2021 increase.	539%	n/a	1.18	\$2,915,109	\$456,000	2020	n/a	n/a
PGE_Res_001a (e)	Pay for Performance – Comfortable Home Rebates	Third-Party	Local	Program budget increase reflect funds needed to cover 2021 M&V payments resulting from prior-year projects, and increased participant enrollment in 2021. Additionally, program activities from Energy Upgrade California (PGE21004) and Residential HVAC (PGE21006) have moved under the Pay for Performance-CHR new 2021 Program ID (PGE_Res_001a). See the “Program ID Changes Resulting from Program ID Reorganization” and accompanying Table 11 of section III.G. of the Advice Letter for more details.	57%	0.00	0.41	\$3,478,918	\$4,835,316	2016	n/a	n/a
PGE_Res_001b (e)	Pay for Performance – Home Intel	Third-Party	Local				0.19	\$667,404			n/a	n/a
PGE_Res_001c (e)	Pay for Performance – Home Energy Rewards	Third-Party	Local				0.83	\$757,322			n/a	n/a
PGE_Res_001d (e)	Pay for Performance – Home Energy Optimization	Third-Party	Local				0.38	\$2,690,921			n/a	n/a

PG&E 2021 EE ABAL Attachment 2 – Program Changes Tables

**Programs with enhanced budgets (>40% budget increase)**

Program ID	Program Name	Third-Party Implementer or Core	Statewide or Local	PA justification (a)	% change	2020 Claimed TRC	2021 Filed TRC (b)	2021 ABAL Budget	2020 ABAL Budget	Year program started (c)	For existing third party implemented programs, MM/YY Program was due to sunset prior to PY 2021 ABAL planning and new 3P contracting (d)	For existing third party implemented programs, MM/YY Program is extended to as a result of PY 2021 ABAL planning and timing for new 3P contracts' ramp up (d)
PGE210212	Compressed Air and Vacuum Optimization Program	Third-Party	Local	Ramping down in anticipation of SW replacement program overlap.	174%	0.00	0.70	\$795,251	\$290,275	2017	n/a	n/a
PGE21022	Industrial Deemed Incentives	Core	Local	Increased budget to finish existing projects and gap-fill for new third-party programs.	57%	2.09	1.22	\$238,153	\$151,294	2013	n/a	n/a
PGE21031	Agricultural Calculated Incentives	Core	Local	Increased budget to finish existing projects and gap-fill for new third-party programs.	173%	0.00	0.57	\$5,310,769	\$1,947,535	2013	n/a	n/a
PGE21063	Technology Introduction Support	Core	Local	Introducing new program activities for heat pump water heater replacement, including fuel substitution measures.	123%	n/a	n/a	\$3,322,253	\$1,490,116	2013	n/a	n/a
PGE210911	On-Bill Financing Alternative Pathway	Core	Local	Transitioning majority of OBF projects (and OBF administration) to the Alternative Pathway model.	408%	0.00	1.03	\$4,030,576	\$793,414	2013	n/a	n/a

(a) See advice letter Section III.G, Tables 7 through 12 for more details on program changes justification.

(b) 2021 filed TRC represents reported results through Q1. TRC values are not representative of full-year performance, and are subject to change in future quarters. Any erroneous reporting values will be corrected in future reporting quarters.

(c) 2013 is the earliest program start year in this table because the majority of current Program IDs were introduced in 2013. Some programs may have been present prior to 2013 under a different (or possibly the same) program ID.

(d) In some cases the contract end date is unknown at the month level, in which case months are marked "TBD". Contract extension dates for program budgets increasing or decreasing by 40% or more are marked as "n/a" because contracts will be in place at least through the end of 2021.

(e) PGE\_Res\_001a, PGE\_Res\_001b, PGE\_Res\_001c, and PGE\_Res\_001d are new Program IDs for the four Pay for Performance implementers of the Pay for Performance program activities for 2021 that were previously forecasted and reported through 2020 under Program ID PGE210010. See the "Program ID Changes Resulting from Program ID Reorganization" section and accompanying Table 12 below for more details. The % budget change for PGE\_Res\_001a, PGE\_Res\_001b, PGE\_Res\_001c, and PGE\_Res\_001d is based on the total 2021 program budgets for these four new Program IDs compared to the 2020 program budget for Pay for Performance (PGE210010).

PG&E 2021 EE ABAL Attachment 2 – Program Changes Tables

**Programs that are new in 2021**

Program ID	Program Name	Third-Party Implementer or Core	Statewide or Local	PA justification <sup>(a)</sup>	% change	2020 Claimed TRC	2021 Filed TRC <sup>(b)</sup>	2021 ABAL Budget	2020 ABAL Budget	Year program started <sup>(c)</sup>	For existing third party implemented programs, MM/YY Program was due to sunset prior to PY 2021 ABAL planning and new 3P contracting <sup>(d)</sup>	For existing third party implemented programs, MM/YY Program is extended to as a result of PY 2021 ABAL planning and timing for new 3P contracts' ramp up <sup>(d)</sup>
PGE_Ag_001	Agriculture Energy Savings Action Plan	Third-Party	Local	Local solicitations	n/a	n/a	1.39	\$5,741,691	\$0	TBD/2021	n/a	n/a
PGE_Com_001	Grocery Comprehensive Retrofit & Commissioning	Third-Party	Local	Local solicitations	n/a	n/a	0.94	\$921,180	\$0	TBD/2021	n/a	n/a
PGE_Com_002	Smart Labs	Third-Party	Local	Local solicitations	n/a	n/a	0.00	\$731,411	\$0	TBD/2021	n/a	n/a
PGE_Ind_002	Business Energy Performance Program	Third-Party	Local	Local solicitations	n/a	n/a	1.30	\$5,934,442	\$0	TBD/2021	n/a	n/a
PGE_Ind_003	Industrial Systems Optimization Program	Third-Party	Local	Local solicitations	n/a	n/a	0.90	\$4,720,291	\$0	TBD/2021	n/a	n/a
PGE_Pub_009	Government & K-12 Comprehensive Program	Third-Party	Local	Local solicitations	n/a	n/a	1.27	\$3,224,434	\$0	TBD/2021	n/a	n/a
PGE_Pub_010	RAPIDS Wastewater Treatment Optimization Program	Third-Party	Local	Statewide solicitations	n/a	n/a	0.24	\$629,350	\$0	TBD/2021	n/a	n/a
PGE_Res_003	Multifamily Energy Savings Program	Third-Party	Local	Statewide solicitations	n/a	n/a	1.09	\$4,168,929	\$0	TBD/2021	n/a	n/a
PGE_Pub_001	Central Coast Leaders in Energy Action Program	Third-Party	Local	Statewide solicitations	n/a	n/a	0.00	\$346,341	\$0	TBD/2021	n/a	n/a
PGE_Pub_002	Marin Energy Watch Partnership	Third-Party	Local	Statewide solicitations	n/a	n/a	0.00	\$277,907	\$0	TBD/2021	n/a	n/a
PGE_Pub_003	Redwood Coast Energy Watch	Third-Party	Local	Statewide solicitations	n/a	n/a	0.00	\$374,846	\$0	TBD/2021	n/a	n/a
PGE_Pub_004	Central California Energy Watch	Third-Party	Local	Local solicitations	n/a	n/a	0.00	\$800,802	\$0	TBD/2021	n/a	n/a
PGE_Pub_005	San Mateo County Energy Watch Program	Third-Party	Local	Local solicitations	n/a	n/a	0.00	\$448,606	\$0	TBD/2021	n/a	n/a
PGE_Pub_006	Energy Access SF	Third-Party	Local	Local solicitations	n/a	n/a	0.00	\$1,004,578	\$0	TBD/2021	n/a	n/a
PGE_Pub_007	Sierra Nevada Energy Watch	Third-Party	Local	Local solicitations	n/a	n/a	0.00	\$746,897	\$0	TBD/2021	n/a	n/a
PGE_Pub_008	Sonoma Public Energy	Third-Party	Local	Statewide solicitations	n/a	n/a	0.00	\$396,496	\$0	TBD/2021	n/a	n/a
PGE_SW_FS	Food Service POS	Third-Party	SW	Local solicitations	n/a	n/a	1.35	\$4,598,474	\$0	TBD/2021	n/a	n/a



PG&E 2021 EE ABAL Attachment 2 – Program Changes Tables

**Programs that are new in 2021**

Program ID	Program Name	Third-Party Implementer or Core	Statewide or Local	PA justification (a)	% change	2020 Claimed TRC	2021 Filed TRC (b)	2021 ABAL Budget	2020 ABAL Budget	Year program started (c)	For existing third party implemented programs, MM/YY Program was due to sunset prior to PY 2021 ABAL planning and new 3P contracting (d)	For existing third party implemented programs, MM/YY Program is extended to as a result of PY 2021 ABAL planning and timing for new 3P contracts' ramp up (d)
PGE_SW_UL	Lighting (Upstream)	Third-Party	SW	Local solicitations	n/a	n/a	1.07	\$3,824,503	\$0	TBD/2021	n/a	n/a
PGE_SW_MCWH	Midstream Comm Water Heating	Third-Party	SW	Local solicitations	n/a	n/a	2.91	\$4,546,753	\$0	TBD/2021	n/a	n/a
PGE_SW_ETP_Gas	Emerging Technologies Program, Gas	Third-Party	SW	Local solicitations	n/a	n/a	0.00	\$1,537,675	\$0	TBD/2021	n/a	n/a
PGE_SW_PLA	Plug Load and Appliance	Third-Party	SW	Local solicitations	n/a	n/a	0.98	\$3,469,126	\$0	TBD/2021	n/a	n/a
PGE_SW_HVAC_Up	Upstream HVAC (Comm + Res)	Third-Party	SW	Local solicitations	n/a	n/a	1.42	\$5,050,941	\$0	TBD/2021	n/a	n/a
PGE_SW_WET_CC	WE&T Career Connections	Third-Party	SW	Local solicitations	n/a	n/a	0.00	\$372,802	\$0	TBD/2021	n/a	n/a
PGE_SW_WET_WORK	WE&T Career and Workforce Readiness	Third-Party	SW	Local solicitations	n/a	n/a	0.00	\$702,647	\$0	TBD/2021	n/a	n/a
PGE_SW_IP_Gov	Institutional Partnerships: Department of General Services and Department of Corrections and Rehabilitation	Third-Party	SW	Local solicitations	n/a	n/a	0.00	\$256,545	\$0	TBD/2021	n/a	n/a

(a) See advice letter Section III.G, Tables 7 through 12 for more details on program changes justification.

(b) 2021 filed TRC represents reported results through Q1. TRC values are not representative of full-year performance, and are subject to change in future quarters. Any erroneous reporting values will be corrected in future reporting quarters.

(c) 2013 is the earliest program start year in this table because the majority of current Program IDs were introduced in 2013. Some programs may have been present prior to 2013 under a different (or possibly the same) program ID.

(d) In some cases the contract end date is unknown at the month level, in which case months are marked "TBD". Contract extension dates for program budgets increasing or decreasing by 40% or more are marked as "n/a" because contracts will be in place at least through the end of 2021.

## **Attachment 3**

### **Supplemental Budget Tables**

**PG&E 2021 ABAL Attachment 3 – Supplemental Budget Tables**

**Table of Contents**

- I. DESCRIPTION OF IN-HOUSE EE ORGANIZATIONAL STRUCTURE & ASSOCIATED COSTS ..... 2
  - A. Narrative description of in-house departments/organizations supporting the PA's EE portfolio ..... 2
  - B. Table showing PA EE "Full Time Equivalent" headcount by department/organization ..... 3
  - C. Table showing costs by functional area of management structure ..... 3
  - D. Table showing cost drivers across the EE organization ..... 4
  - E. Explanation of allocation of labor and O&M costs between EE-functions and GRC- functions or other non-EE functions ..... 4
- II. BUDGET TABLES INCLUDING INFORMATION IDENTIFIED IN THE SCOPING MEMO ..... 7
  - A. Attachment-A, Question C.8 ..... 7
  - B. Attachment-A, Question C.9 ..... 7
  - C. Attachment-A, Question C.10 ..... 7

## PG&E's Supplemental Budget Information

On August 8, 2019, PG&E, the Public Advocates Office (Cal PA), and The Utility Reform Network (TURN), met and conferred to discuss the supplemental budget information for inclusion in the Program Administrators' (PAs) 2021 Annual Budget Advice Letter filings. The three parties agreed on a template to be submitted with each PA's 2021 Annual Budget Advice Letter (ABAL). PG&E submits the following information pursuant to its agreement with Cal PA and TURN and in support of its 2021 ABAL.

### I. DESCRIPTION OF IN-HOUSE ENERGY EFFICIENCY (EE) ORGANIZATIONAL STRUCTURE & ASSOCIATED COSTS

#### A. Narrative description of in-house departments/organizations supporting the Program Administrator's (PA) EE portfolio

1. Functions conducted by each department/organization.

PG&E's "Narrative Description – Functions Conducted by Each Department/Organization" is provided in Appendix I.A.1. of this Attachment 3 for Supplemental Budget Information.

2. Management structure and organizational chart.

An organizational chart depicting the management structure of PG&E's Energy Efficiency Department is provided in Appendix I.A.2 of this Attachment 3 for Supplemental Budget Information.

3. Staffing needs by department/organization, including current and forecast for 2021, as well as a description of what changes are expected in the near term (2022-23) or why it is impossible to predict beyond 2021, if that is the Program Administrator's position.

PG&E's staffing for 2019 and 2021 forecast are provided in the "Portfolio Headcount (FTE)" table in Appendix I.C. PG&E cannot currently predict EE staffing needs by department/organization beyond 2021 because staffing needs are contingent upon the outcome of statewide and third-party program solicitations and ongoing portfolio balancing activities. PG&E will continue to identify opportunities to reduce labor costs over time.

Therefore, PG&E forecasted some reductions in 2021 in anticipation of these changes but is not able to predict beyond 2021 until PG&E knows the result of portfolio balancing and the level of PA support needed by new implementers. For example, if implementers opt-in to additional Informational Technology (IT), Marketing, or Sales team support, PG&E's costs in these functions could increase. As PG&E heads into 2021 with more information, PG&E can provide an update to our 2022 ABAL forecasts.

4. Non-program functions currently performed by contractors (e.g. advisory consultants), as well as a description of what changes are expected in the near term (2022-2023) or why it's impossible to predict beyond 2021, if that is the PA's position.

All costs charged to the EE balancing account (i.e., the cost reflected in section I. C, below) support PG&E's EE programs. As such, there are no "non-program" costs to disclose. PG&E does not foresee any change in this practice.

5. Anticipated drivers of in-house cost changes by department/organization.

PG&E lists its drivers of in-house cost changes by department/organization in the table in Appendix I.A.5. of this Attachment 3 for Supplemental Budget Information.

6. Explanation of method for forecasting costs.

PG&E's 2021 ABAL was forecasted using forecasting inputs for new local third-party programs, new statewide programs, and continuing existing programs. Forecast data for its new local third-party programs were based on inputs submitted by the third parties that were awarded contracts through PG&E's solicitations. In cases where commercial and residential sector new third-party program contracts are still pending, PG&E included placeholder forecasts. For new statewide programs in PG&E's forecast in which PG&E is the lead PA, PG&E developed the forecasts. For new statewide programs led by another PA, PG&E used forecast data provided by the lead PA.

Forecast staffing levels reflect anticipated reductions due to PG&E's continued focus on driving out labor costs by finding efficiencies in PG&E's program delivery activities. Actual costs may vary depending on the result of portfolio balancing and the level of PA support needed by PG&E's new implementers.

**B. Table showing PA EE "Full Time Equivalent" (FTE) headcount by department/organization.**

The table showing PG&E full-time equivalent headcount can be found in Appendix I.B. of this Attachment 3 for Supplemental Budget Information.

**C. Table showing costs by functional area of management structure.**

PG&E provides the requested information in multiple tables in Appendix I.C. of this Attachment 3 for Supplemental Budget Information:

- Function Definitions Table,
- Residential Budget Detail,
- Commercial Budget Detail,
- Agricultural Budget Detail,
- Industrial Budget Detail,
- Public Sector Budget Detail, and
- Cross-Cutting Budget Detail.

These tables itemize expenses into labor, non-labor O&M (with contract labor identified).

There were no associated capital costs.

**D. Table showing cost drivers across the EE organization**

The following table shows the major cost drivers across PG&E's EE organization. As recommended by TURN and Cal PA, this table is based on the format of testimony concerning cost drivers in PG&E's 2017 general rate case (GRC).

Cost Driver	2019 Expenditures	2021 Forecast	Difference
Program Design and Delivery	\$255.4	\$195.6	-\$59.8
Program Fulfillment	\$2.8	\$2.1	-\$0.7
Operations Support	\$14.3	\$13.5	-\$0.8
<b>Total*</b>	<b>\$272.5</b>	<b>\$211.2</b>	<b>-\$61.3</b>

\*This is the Total Sector Budget, which excludes EM&V, DSM, On Bill Financing (OBF) Loan Pool, Bay Area Regional Network (BayREN), Marin Clean Energy (MCE), and Tri-County Regional Network (3C-REN).

Program Design and Delivery – overall decrease in cost primarily associated with the following drivers:

- Existing program ramp-down in anticipation of new programs.
- Addition of third-party and statewide contracts.
- Decrease in staffing due to operational efficiencies.

Program Fulfillment – Overall decrease in staffing costs due to fewer custom projects for inspections and fewer rebates being processed.

Operations Support —Primarily driven by lower IT O&M costs and reduction in discretionary IT project spend. Absorbing costs for additional Policy, Strategy and Regulatory Reporting Compliance activity within the EE proceeding since 2019, including working towards statewide and outsourcing portfolio compliance targets, NMEC policy and reporting, potential and goals analysis and related filings, revised Business Plan development, continued ABAL filings, market transformation framework participation, among other activities.

**E. Explanation of allocation of labor and O&M costs between EE-functions and GRC- functions or other non-EE functions**

1. When an employee spends less than 100% of her/his time on EE, how are costs tracked and recovered (e.g., on a pro rata basis between EE rates and GRC rates; when time exceeds a certain threshold, all to EE; etc.).

PG&E employees fill out timesheets each week and charge their hours worked to order numbers. Typically, an employee will charge a maximum of 40 hours per week. Order numbers are the accounting vehicle for capturing costs of the EE subprograms, as well as non-EE programs (demand response (DR), Energy Savings Assistance (ESA), etc.) and GRC-related activities. Each order number is assigned attributes that allow for the accurate reporting of charged costs. There are unique attributes assigned to each order that identify the following information used

for regulatory reporting:

- Funding Cycle (e.g., EE, DR, ESA, etc.)
- EE Program or Sector (e.g., Residential, Commercial, Industrial, etc.)
- EE Subprogram (e.g., Energy Upgrade California (EUC) Home Upgrade, Commercial Calculated Incentives, etc.)
- Cost Category (e.g., Administrative, Marketing, Implementation, EM&V)
- Program Type (e.g., Resource, Non-resource)
- Delivery Channel (e.g., Core, Third-party, Governmental Partnerships)

Each order number can only be assigned one attribute from each of the above reporting categories. For example, an order cannot be assigned multiple funding cycles. Costs charged to an order can only be identified and reported as either EE or DR or ESA or GRC, etc. An order can only be identified and reported to only one Sector, only one Subprogram, only one Cost Category, etc.

Because of this model of charging and categorizing costs, when an employee fills out a timesheet, the employee must choose an order or orders that reflect the work functions performed during the week. There is a dropdown menu on the timesheet in which the employee selects the appropriate order number that reflects the work performed. For example, assume that a PG&E employee performed implementation functions for the Energy Upgrade California subprogram that is part of the current EE funding cycle for 24 hours during one week. The employee must choose an order number that describes the subprogram, funding cycle, and cost category of the work performed. The employee would accordingly record 24 hours associated with that order. Then, assume that the same employee also worked 16 hours in the same week on some GRC activities. The employee would choose a different order number that best describes the GRC activities performed, then record the 16 hours against that GRC order.

Once the timesheet is complete, the employee's supervisor would review and approve it. Because of the existing cost model, costs charged to GRC-related orders should not be reported or charged against authorized EE budgets or recorded in EE balancing accounts. By the same token, costs charged to EE orders should be reported against authorized EE budgets, recorded in the EE balancing accounts, and matched against the electric and gas EE- collected revenue. Management costs and other overheads such as office charges are embedded in the employee hourly rate.

2. Describe the method used to determine the proportion charged to EE balancing accounts for all employees who also do non-EE work.

See the response to Question I.E.1, above.

3. Identify the EE functions that are most likely to be performed by employees who also do non-EE work (e.g. Customer Account Representatives?)

PG&E identifies the following functions:

- Account Management / Sales
- Engineering Services support (Applied Technical Services Organization)
- EM&V
- Call Centers
- Marketing, Education and Outreach (ME&O)
- Inspections
- Information Technology (IT and System Administration)
- Program Management support (Sourcing Organization)
- Portfolio Analytics
- Policy, Strategy, and Regulatory Reporting Compliance support (Business Finance Organization, Financial Reporting & Governance)

4. Are labor costs charged to EE fully loaded?

Yes.

5. How are burden benefit-related administrative and general (A&G) expenses for employees who work on EE programs recovered (EE rates or GRC rates)?

PG&E allocates these costs to EE pursuant to a settlement agreement with Marin Clean Energy (MCE) and TURN, which was adopted in Decision (D.)14-08-032. PG&E's burden benefit-related A&G expenses for employees who work on EE programs are litigated through its GRC and are recovered through EE rates.

6. When EE and non-EE activities are supported by the same non-labor resources, how are the costs of those resources or systems allocated to EE and non-EE activities?

Assuming that "non-labor resources" are defined as contractors and consultants, typically a contract would be created that supports only one funding cycle. The contractor would perform work for only EE, only DR or only ESA, etc. within the scope of one contract. However, occasionally there are contracts that support multiple funding cycles. In this situation, when the Purchase Order (PO) for the contract is created, all work and contracted amounts within the scope of the contract are identified as to the funding cycle being supported (EE, ESA, DR, etc.). Separate PO line items representing each funding cycle would be assigned order numbers that roll up to that particular funding cycle. When the contractor performs work on the contract, its invoice should specify enough detail to determine which funding cycle(s) the work pertained to and which PO line item(s) the work should be charged against. When the invoice is paid, the appropriate order numbers are charged and the costs are reported to the corresponding funding cycles.

7. Identify the EE O&M costs that are most likely to be spread to non-EE functions as well as EE, if any

See the list provided in response to Question I.E.3, above.



## II. BUDGET TABLES INCLUDING INFORMATION IDENTIFIED IN THE SCOPING MEMO<sup>1</sup>

### A. Scoping Memo Attachment-A, Question C.8

“Present a single table summarizing energy savings targets, and expenditures by sector (for the six specified sectors). This table should enable / facilitate assessment of relative contributions of the sectors to savings targets, and relative cost-effectiveness.”

1. TURN and ORA invite the PAs to propose a common table format for this information. We don't have anything specific in mind. Additionally, include a brief description of the method used by the PA to estimate the costs presented in the C.8 Table.

A single table labeled “Portfolio Summary” summarizing energy savings targets, and expenditures by sector (for the six specified sectors) can be found in Appendix II.A. of this Attachment 3 for Supplemental Budget Information. Please refer to PG&E’s response to Question I.A.6 for a brief description of the method used by PG&E to estimate the costs presented in this table.

### B. Scoping Memo Attachment-A, Question C.9

“Using a common budget template developed in consultation with interested stakeholders (hopefully agreed upon at a "meet and confer" session), display how much of each year's budget each PA anticipates spending "in-house" (e.g., for administration, non-outsourced direct implementation, other non-incentive costs, marketing), by sector and by cross-cutting program.”

1. TURN and ORA invite the PAs to propose a common table format for this information. We don't have anything specific in mind. Additionally, include a brief description of the method used by the PA to estimate the costs presented in the C.9 Table.

Please refer to the Tables in Section I.C, “Costs by functional Areas of Management Structure,” for PG&E’s estimate of the portion of annual budget that it anticipates spending “in-house” (e.g., for administration, non-outsourced direct implementation, other non-incentive costs, and marketing), by sector and by cross-cutting programs. Please refer to PG&E’s response to Question I.A.6 for a brief description of the method used by PG&E to estimate the costs presented in this table.

### C. Scoping Memo Attachment-A, Question C.10

“Present a table akin to PG&E's Figure 1.9 (Portfolio Overview, p 37) or SDG&E's Figure 1.10 (p. 23) that not only shows anticipated solicitation schedule of "statewide programs" by calendar year and quarter, but also expected solicitation schedule of local third-party solicitations, by sector, and program area (latter to extent known, and/or by intervention

---

<sup>1</sup> A Scoping Memo was issued on April 14, 2017 seeking supplemental budget information from PAs. See D.18-05-041, p.6.

strategy if that is more applicable). For both tables, and for each program entry on the calendar, give an approximate size of budget likely to be available for each solicitation (can be a range)."

1. TURN and ORA invite the PAs to propose a common table format for this information. We don't have anything specific in mind. Additionally, include a brief description of the method used by the PA to estimate the costs presented in the C.10 Table.

PG&E provides a table with its expected solicitation schedule for local third-party solicitations and by sector in Appendix II.C. of this Attachment 3 for Supplemental Budget Information. For PG&E's budgets for Statewide Programs, please refer to the Statewide Budget Table in Table 8 of Attachment 4 of PG&E's 2021 ABAL.

**PG&E 2021 ABAL Attachment 3: Supplemental Budget Information**

**LIST OF ATTACHMENT 3 APPENDICES**

<b>APPENDIX</b>	<b>CONTENTS</b>
<b>I.A1.</b>	<b>Narrative Description – Functions Conducted by Each Department/Organization</b>
<b>I.A.2.</b>	<b>PG&amp;E’s Energy Efficiency Department Organizational Charts</b>
<b>I.A.5.</b>	<b>Drivers of In-House Cost Changes</b>
<b>I.B.</b>	<b>Energy Efficiency “Full Time Equivalent” Headcount: Portfolio Staffing</b>
<b>I.C.</b>	<b>Costs by Functional Area of Management Structure: Function Definitions Residential Budget Detail Commercial Budget Detail Agricultural Budget Detail Industrial Budget Detail Public Sector Budget Detail Cross-Cutting Budget Detail.</b>
<b>II.A.</b>	<b>Question C-8: Portfolio Summary</b>
<b>II.C.</b>	<b>Question C-10: Aggregate Budgets for Statewide Programs EE Programs Solicitation Strategy</b>

## PG&E 2021 ABAL Attachment 3: Supplemental Budget Information

### Appendix I.A1.

#### Narrative Description – Functions Conducted by Each Department/Organization

**Codes and Standards (C&S) & Cross Cutting:** C&S works with local, state, and federal authorities to develop and substantiate new building codes and appliance standards. C&S also supports compliance improvement through development and delivery of education, training, and tools. Major functions and areas of responsibility include Building Energy Codes Advocacy, Appliance Standards, Reach Codes and Planning/Coordination. This team also manages the new construction programs.

**Education Centers (Energy Centers):** This team supports the training centers and delivers classes/events each year to a variety of partners including 3P, Low Income, Contractors, Architects, etc. They also maintain a tools lending library, deliver programs to K-12 schools + community colleges throughout our territory and consult on energy efficiency needs for customers.

**EE Procurement:** This team oversees the implementation of a business strategy to transition at least 60% of the EE budget to fund EE programs proposed, designed, implemented and delivered by third party vendors and at least 25% of EE budget to fund statewide programs by 2022.

**EE Quality Control and Communications (QC&C):** The EE QC&C team includes the Deemed Platform Quality Control (DPQC) team, and the Custom Implementation Team (CIT),. QC&C is also responsible for oversight on EE Meter-based Platform Quality Control—including NMEC Quality Control--as well as our process improvement and guidance document oversight, and EE stakeholder communications and training. DPQC develops and maintains workpaper data that substantiate the energy savings for our deemed products. CIT reviews calculated incentive applications and manages the CPUC's Custom Project Review process for calculated projects. All parts of QC&C support the review of program data including savings claims that will be reported to the CPUC. Overall the QC&C team supports the delivery of accurate and compliant incentive program data across all channels by providing technical support, performing quality assurance activities, and managing EE-related communication and training with internal parties and external vendors.

**Field Engineering Services:** The Field Engineering Services team supports implementation and technical review of our calculated energy efficiency programs through on-site auditing services, calculation assistance, and technical support for our sales and service staff.

**Non-Residential Programs:** This team includes the Commercial Programs, Industrial, Agriculture, & Water Programs (IAW), and financing programs. The Commercial team focuses on leveraging relationships with retailers, manufacturers, distributors and trade professionals to drive access and adoption of EE products and services. In addition, the IAW Program team is responsible for the overall strategy and execution of energy efficiency programs that cater to a wide array of customer segments that include Refineries, Oil Production, Manufacturing, Food

Processing, Water Agencies, Wineries, Dairies and Agricultural Growers. The IAW team is also leading the water-energy nexus related activities. Our financing team oversees On-Bill Financing, our interaction with the Statewide financing pilots, project evaluation tools and EE funding related activities.

**Policy Shaping, Analytics & Compliance:** This team provides strong and sound policy direction and leadership to EE Programs to empower them with the knowledge and tools they need to drive business objectives, achieve EE savings goals, and demonstrate strength in program administration. It also provides direction for future EE portfolio administration. Addresses long-term EE strategic issues and related regulatory and legislative policy issues that arise at state and national levels. Aims to Influence long term policy to advance PG&E's EE goals and ensure PG&E's leadership in EE is well represented in key markets.

**Portfolio Strategy & Optimization:** This team focuses on proactively planning for and overseeing the strategy and health of the EE portfolio

**Residential and Partnership Programs:** This team designs, manages and delivers programs that engage and support residential customers. In addition, this team also manages local and regional partnerships covering nearly every city and county in PG&E's service territory as well as supports four statewide joint-Investor Owned Utilities (IOU) institutional partnerships. The team serves as the Public Sector lead for the EE Portfolio overseeing the strategy and programs that serve cities, counties, public schools, special districts, higher education institutions and state government organizations.

### **Organizations Outside EE that Support EE Activities**

**Application Management:** Application Management includes Enrollment & Incentive Management (E&IM). E&IM manages vendor contract with Parago, PG&E's partner for residential rebate fulfillment services; processes deemed and partner rebates; and supports application processing for the financing programs.

**Applied Technical Services (ATS):** Applied Technology Services (ATS) provides a range of technology-based services across PG&E. These include chemical and site testing, civil and mechanical engineering support, equipment testing and emerging technologies testing, and meteorology operations and analytics, among others.

**Business Development & Customer Engagement (BDCE) Performance Reporting & Analysis:** The BDCE Performance Reporting & Analysis team supports the Business Energy Solutions (BES) and Local Customer Experience (LCE) teams with performance management, quality assurance, process improvement, data mining, analysis, and reporting.

**Business Energy Solutions (BES):** BES manages relationships with PG&E's commercial, industrial, and agricultural customers, helping to manage business customers' energy and cost reduction and service-related needs. It is aligned along key market segments serving large customers and small/medium size businesses to respond to industry trends, customer needs and opportunities as well as provide service and product offerings.

**Business Finance:** Business Finance provides accounting and budgeting support to help manage spending and align it with regulatory and corporate priorities. Business Finance provides direct support for each assigned budget manager.

**Central Inspections:** The Central Inspection Program provides inspection verification of EE and ESA programs and products. CIP validates the physical installation and use of EE and ESA measures that were submitted on applications requesting rebates or incentives. Without the inspection/verification process the business is at risk due to not following CPUC/Business program guidelines and/or possible fraud by vendors or customer claiming rebates/incentives they are not authorized to receive.

**Customer Care Business Operations:** The Business Operations team supports all of Customer Care (including EE) with transactional financial management including posting invoices and accruals, contract management, quality assurance, compliance, process improvement, and reporting. The team is also responsible for developing and implementing customer privacy and governance, overseeing risk management, regulatory compliance, and leads various significant Customer Care-wide projects and manages their transition to operation (such as records management).

**Customer Insights and Experience (CIX):** Customer Insights & Experience serves as a resource for any PG&E department seeking information about customers for strategic and tactical decision-making purposes. The team conducts primary research regarding general customer behavior, attitudes, and profiles, or for specific programs, policies, and projects, maintains customer database and conducts data analysis, and delivers actionable insights and strategies at both the enterprise level and for individual business units.

**Data and Energy Management Products:** The Data and Energy Management Products team leverages data of all kinds to better serve customers; works across the organization to tackle cross-cutting strategic issues related to customer data access and data governance. It also develops, manages and coordinates PG&E's broad portfolio of interval data-based research and analytical projects spanning Time Varying Rates, Distributed Generation and Energy Efficiency.

**EE Evaluation, Measurement, and Verification (EM&V):** conducts EE market and program evaluations for the purposes of program improvement, and to inform long-term program and policy planning. The team works to ensure that CPUC EM&V study methods and implementation provide results and savings values that are reasonable, reliable, actionable and accurate. In addition, the team provides support for development of EE goals and potential, long-term EE savings forecasts, and cost-effectiveness calculations.

**Energy Insight (System Administration):** The System Administration team is responsible for developing and implementing the long-term strategy of energy efficiency platforms; maintaining existing energy efficiency platforms and integrating the Energy Insight platform into the business; developing a governance process across energy efficiency platforms; and partnering with IT to ensure projects and enhancements are aligned with our long-term strategy.

**Financial Reporting & Governance (FR&G):** In collaboration with Business Finance, FR&G develops long-range financial plans for regulatory filings; facilitates the annual budget planning process and quarterly forecasting process; and provides financial support including benchmarking activities and audit support for all balancing accounts. FR&G also leads supplier diversity activities for Customer Care.

**Information Technology (IT):** The Information Technology organization designs, develops, operates and maintains the technology and telecommunications systems that enable PG&E to meet its commitment to providing safe, reliable and affordable service to customers. IT supports

the business by improving service quality, increasing capabilities through the development of additional functionality, implementing new technologies, reducing costs, increasing productivity, and facilitating organizational and business effectiveness through enabling technologies.

**Law:** The Law Department provides high quality advice, counsel, and representation of the Company. It provides actionable feedback to the lines of business in order to identify and reduce areas of risk, based on claims, lawsuits, and other legal activities.

**Local Customer Experience (LCE):** The Local Customer Experience team strengthens the outreach and program support offered to customers, communities and internal partners by the Customer Impact team.

**Call Center:** PG&E operates 5 call centers throughout its service territory to respond to customer inquiries.

**Smarter Energy Line (SEL):** Smarter Energy Line (SEL) is a designated group of call center representatives that provide residential customers information about energy reduction, energy savings, rebates, energy efficient appliance options, Energy Partners, and PG&E's many program offerings. The team's main goal is "customer education" and providing targeted assistance to customers who have recently had their Energy Cost Inquiries resolved.

**Solutions Marketing:** Solutions Marketing collaborates with various CES groups to produce marketing campaigns and collateral and provide marketing support to deliver on its vision of elevating the importance of energy management to PG&E customers by offering them unique and simple solutions.

**Sourcing:** The Sourcing organization is the functional lead for the procurement of materials and services. The department collaborates with internal clients and suppliers to develop mutually beneficial total cost solutions for goods and services. To provide dedicated and expert service, the Sourcing organization is segmented into the following functional groups: Electric Sourcing, Gas Sourcing, IT Sourcing, and Generation Supply Chain.

PG&E 2021 ABAL Attachment 3: Supplemental Budget Information

Appendix I.A.2.

PG&E's Energy Efficiency Department Organizational Charts as of August 3, 2020

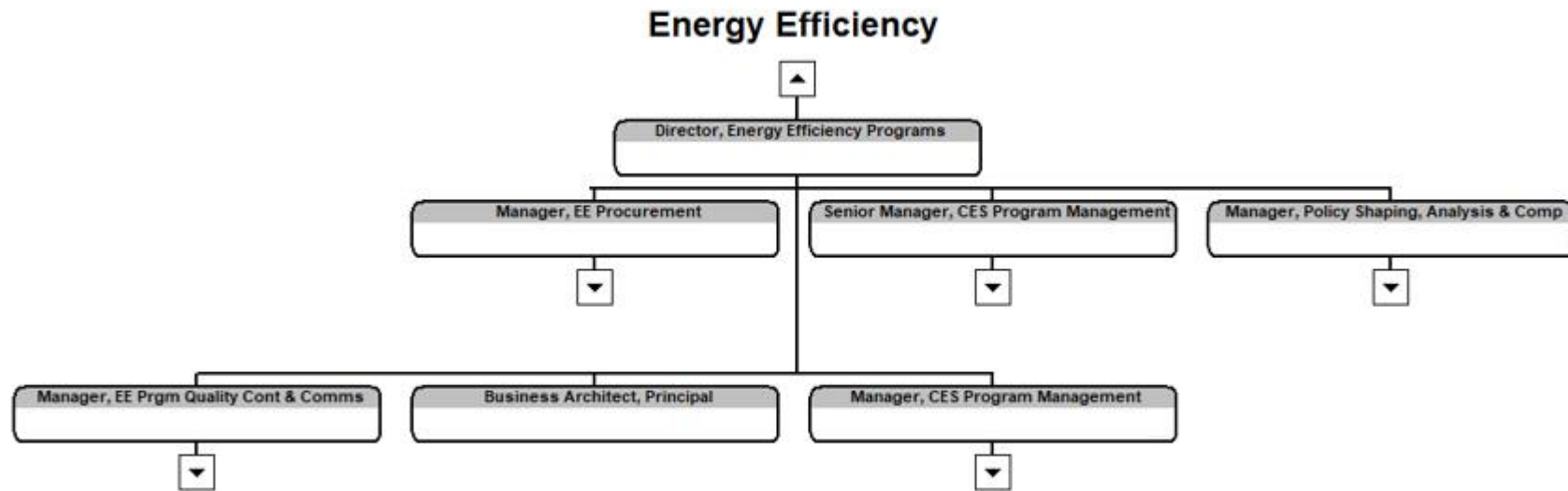



## EE Procurement

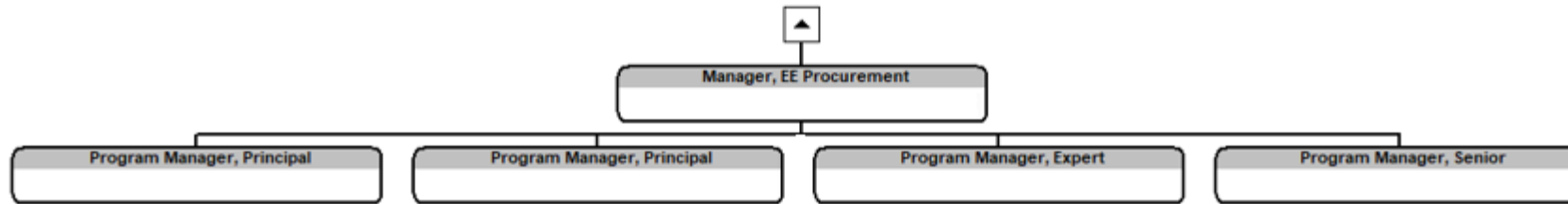

## Portfolio Strategy & Program Oversight

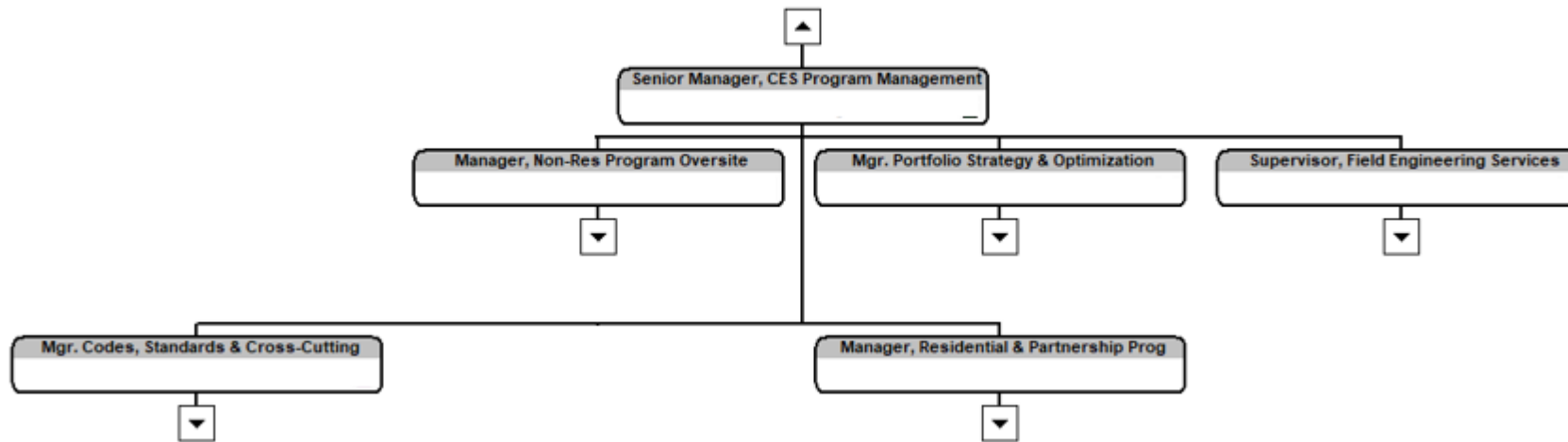

### Non-Residential Program Oversight

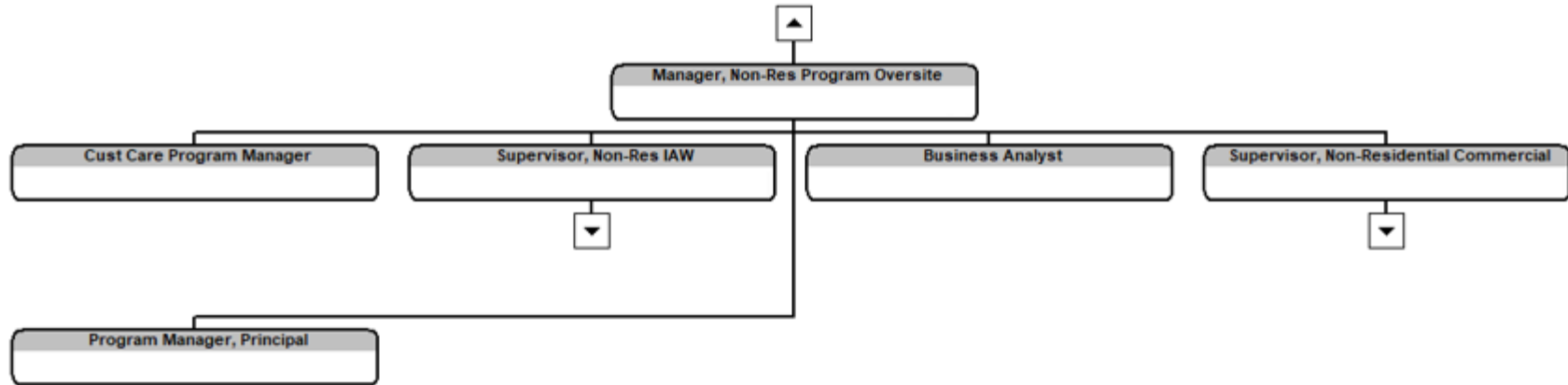

### Non-Res IAW Programs

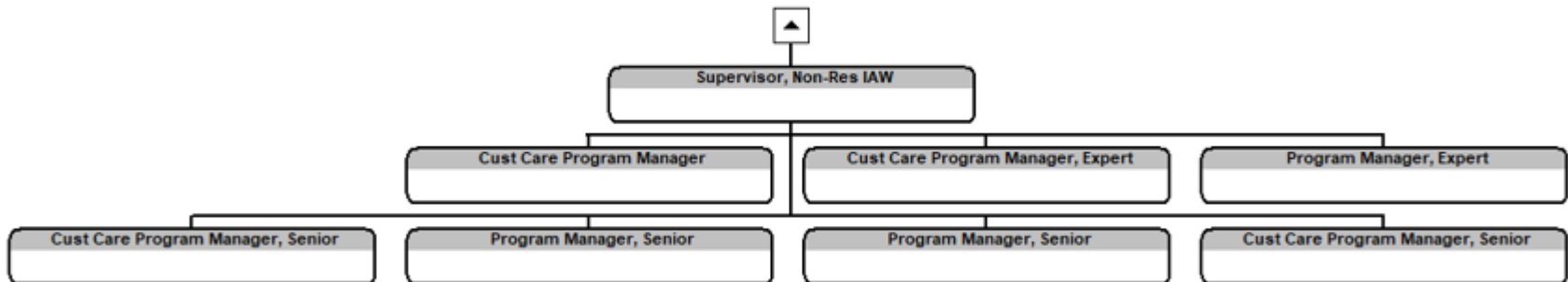

## Non-Residential Commercial

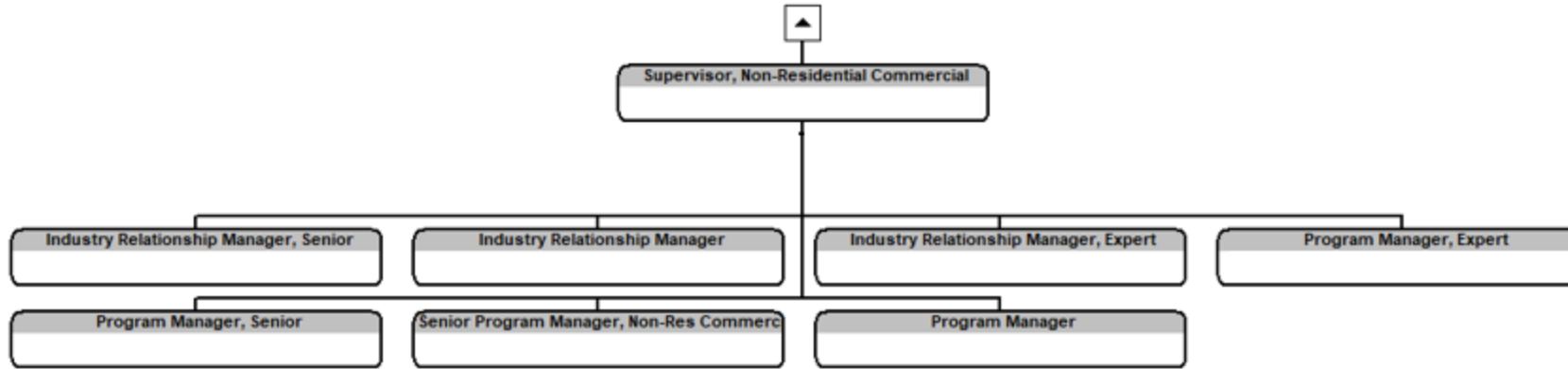

## Portfolio Strategy & Optimization

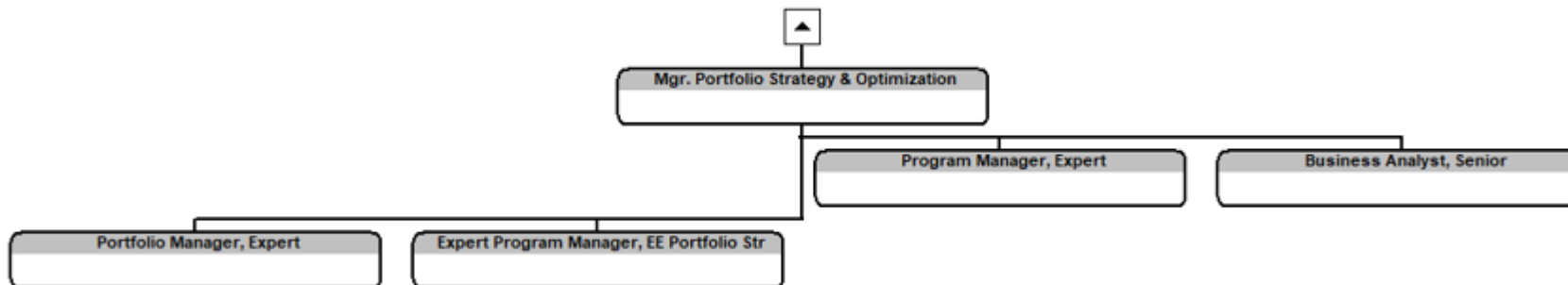

## Field Engineering Services

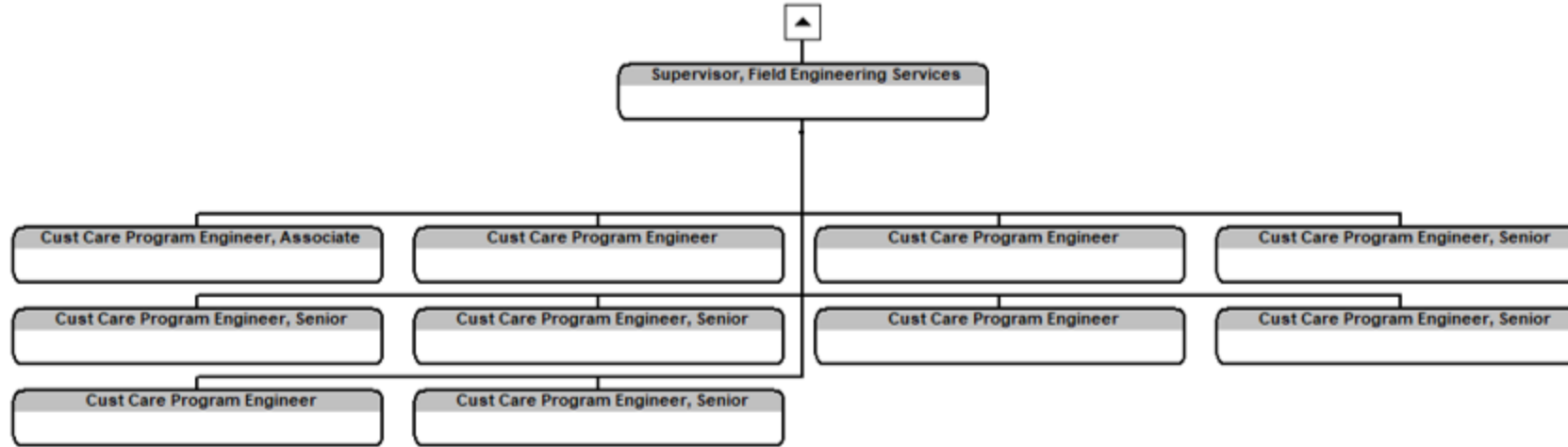

## Codes, Standards & Cross-Cutting

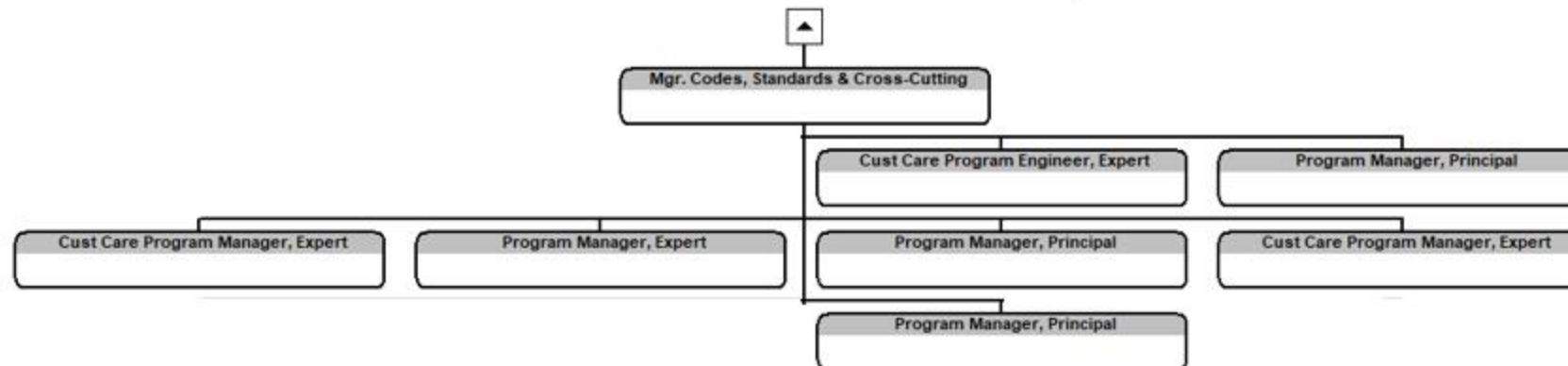

**Residential & Partnership Prgms**



### Policy Shaping, Analytics & Compliance

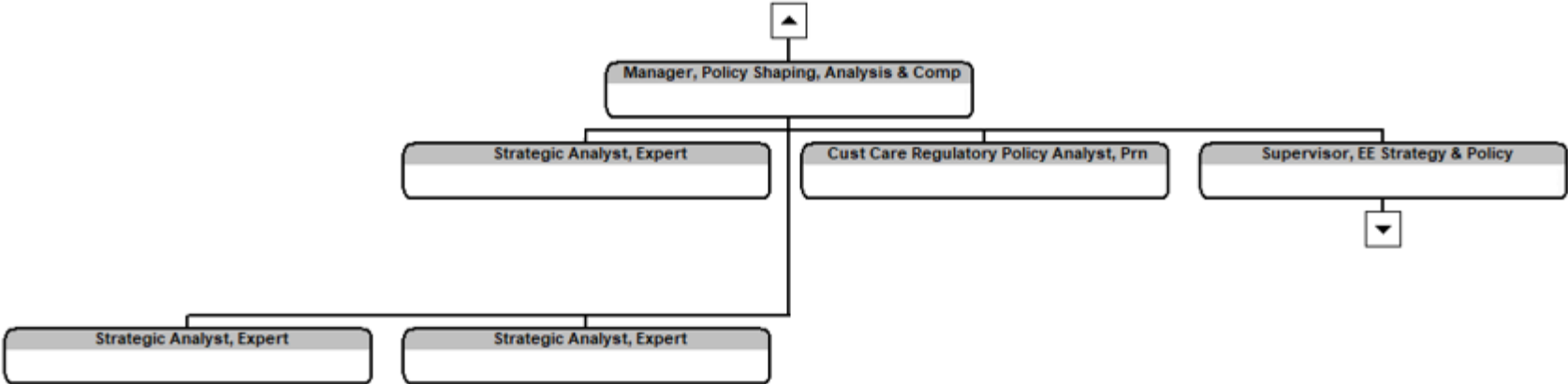

### Policy and Reporting

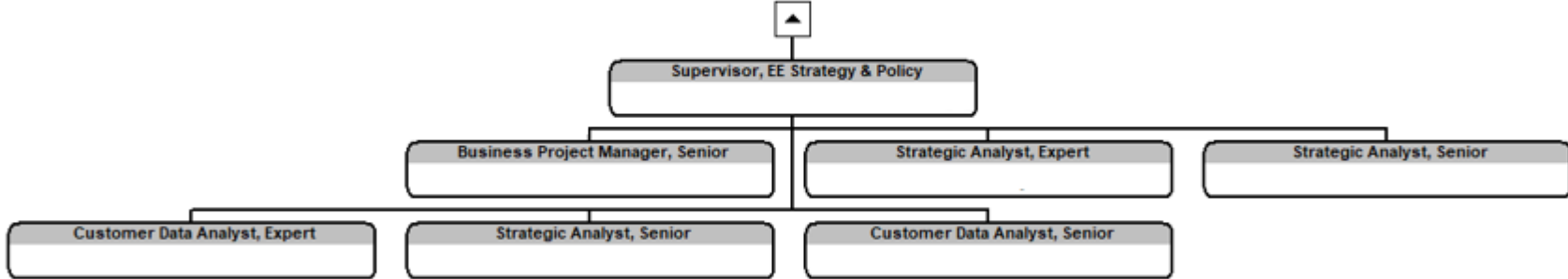

## EE Prgm Quality Control & Communications

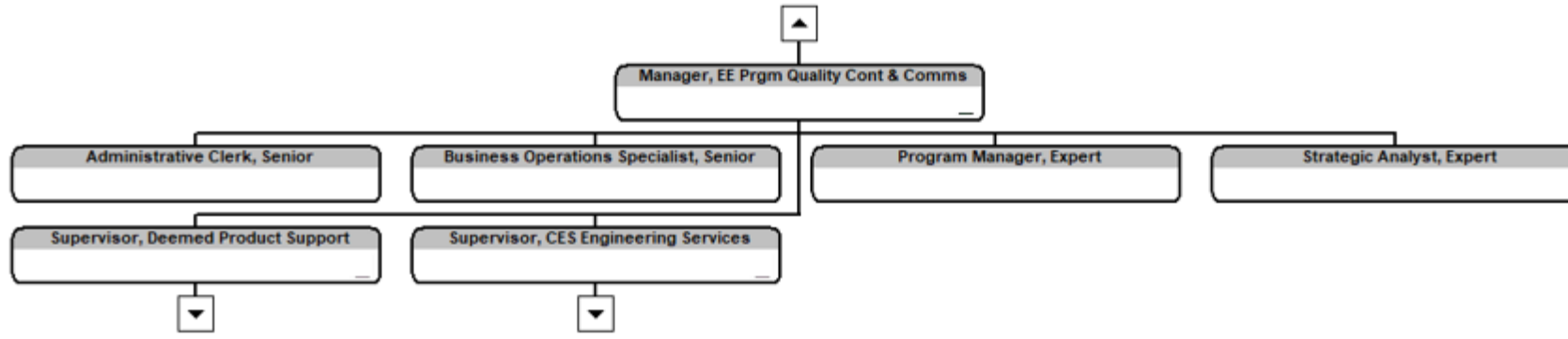

## Deemed Product Support

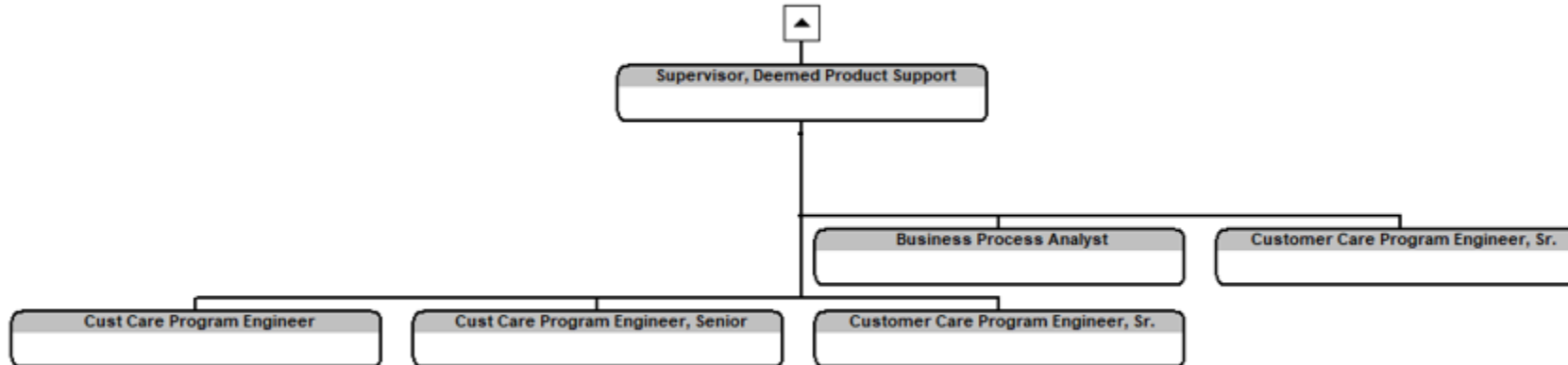

### Custom Implementation

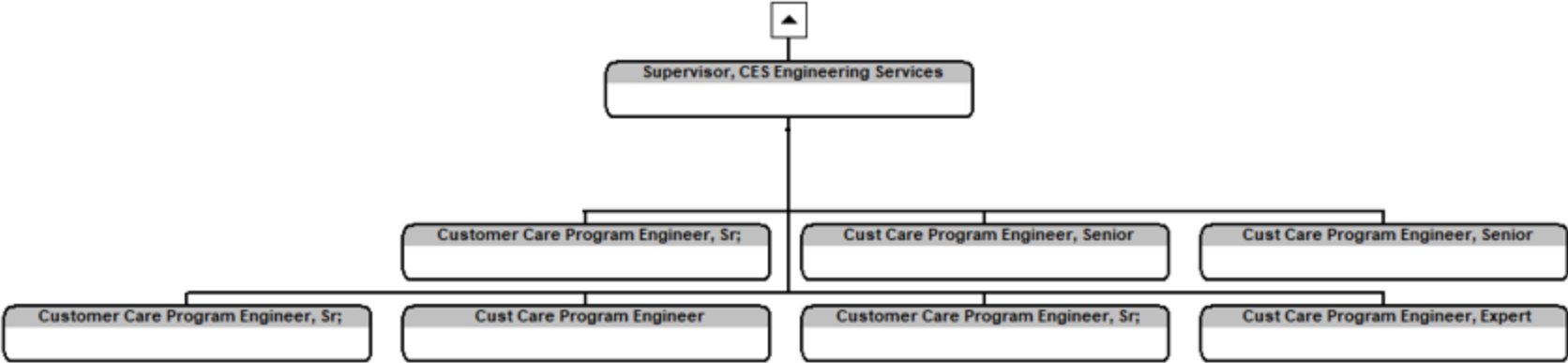

### Workforce Education & Training

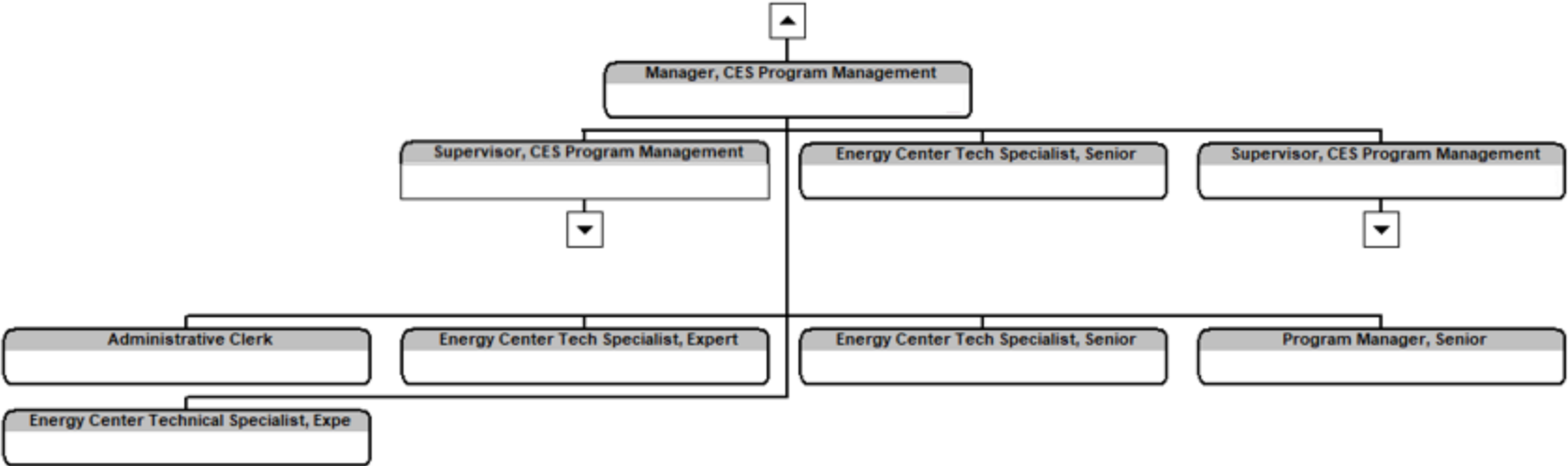



### Energy Centers, Commercial

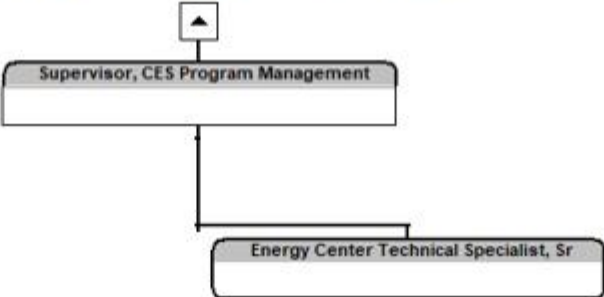

### Energy Centers, Residential

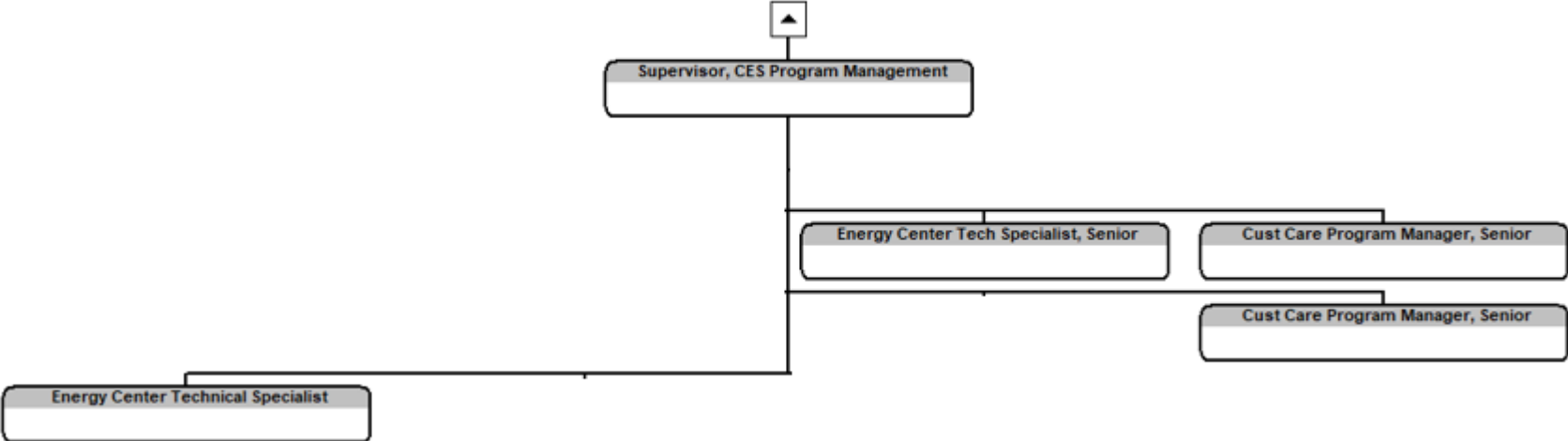

## Organizations Outside of EE

- Application Management
- Applied Technical Services
- BDCE Performance Reporting & Analysis
- Business Energy Solutions
- Business Finance
- Central Inspections
- Customer Care Business Operations
- Customer Insights and Experience
- Data and Energy Management Products
- EM&V
- System Administration
- Financial Reporting & Governance
- IT
- Law
- Local Customer Experience
- Call Center
- Smarter Energy Line
- Solutions Marketing
- Sourcing

**PG&E 2021 ABAL Attachment 3: Supplemental Budget Information**

**Appendix I.A.5.  
Drivers of In-House Cost Changes**

Sector	Cost Element	Functional Group	2019 EE Expenditures (\$Million)	2021 EE Budget (\$Million)	Difference	Drivers
<b>PG&amp;E Portfolio including EM&amp;V and DSM, excluding OBF Loan Pool</b>	Labor (1)	Policy, Strategy, and Regulatory Reporting Compliance	\$3.9	\$3.9	\$0.0	Absorbing costs for additional activity within the EE proceeding since 2019, including working towards statewide and outsourcing portfolio compliance targets, NMEC policy and reporting, potential and goals analysis and related filings, revised Business Plan development, continued ABAL filings, market transformation framework participation, among other activities.
		Program Management	\$13.7	\$12.3	-\$1.4	Reduction in PM staffing as more of the Portfolio transitions to 3rd party implemented programs.
		Engineering services	\$6.4	\$6.6	\$0.2	Plan to transition down consultant work and bring it back in house, as well as scale with lower demand for custom work.
		Customer Application/Rebate/Incentive Processing	\$1.9	\$1.4	-\$0.5	Reduction in rebate processing as volume is lower.
		Customer Project Inspections	\$0.7	\$0.6	-\$0.2	Decreased volume in project inspections.
		Portfolio Analytics	\$1.2	\$1.0	-\$0.2	Small decrease due to efficiencies in analytical processes.
		ME&O (Local)	\$2.4	\$2.4	\$0.0	Immaterial.
		Account Management / Sales	\$9.2	\$8.7	-\$0.5	Reduction in account management staffing due to lower volume in PG&E-led core programs and overall decrease in EE projects in the Non-Residential sectors (Commercial, Industrial, Agriculture, Public)
		IT	\$4.5	\$3.6	-\$0.9	Decrease due to lower O&M costs and reduction in discretionary project spend.
		Call Center	\$0.4	\$0.4	\$0.0	Immaterial.
		EM&V	\$1.2	\$1.1	-\$0.1	Immaterial.
	<b>Labor Total</b>		\$45.6	\$42.1	-\$3.5	Reduction includes absorbing two years of annual inflation.

Sector	Cost Element	Functional Group	2019 EE Expenditures (\$Million)	2021 EE Budget (\$Million)	Difference	Drivers
	Non-Labor	Third-Party Implementer Contracts (as defined per D.16-08-019, OP 10)	\$15.1	\$67.4	\$52.4	N/A as these are outsourced costs and the question asks for drivers of in-house costs.
		Local/Government Partnerships Contracts (3)	\$11.6	\$0.0	-\$11.6	N/A as these are outsourced costs and the question asks for drivers of in-house costs. Note: Local/Government Partnerships Contracts have been re-contracted and are now included as Third-Party Implementer Contracts.
		<b>Other Contracts</b>				
		Program Implementation	\$70.0	\$31.0	-\$39.0	Reduced existing programs' contracts spend to make room for new third-party and statewide contracts.
		Policy, Strategy, and Regulatory Reporting Compliance	\$0.8	\$1.2	\$0.4	CAEECC and other ad hoc regulatory support contracts (e.g. Potential and Goals).
		Program Management	\$2.7	\$2.2	-\$0.4	Reduction in contractors supporting program management.
		Engineering services	\$6.8	\$4.7	-\$2.1	Plan to transition down consultant work and bring it back in house, as well as scale with lower demand for custom work.
		Customer Application/Rebate/Incentive Processing	\$0.2	\$0.2	\$0.0	Immaterial.
		Customer Project Inspections	\$0.0	\$0.0	\$0.0	Immaterial.
		Portfolio Analytics	\$0.0	\$0.0	\$0.0	Immaterial.
		ME&O (Local)	\$5.9	\$4.7	-\$1.2	Reduction in Marketing costs as Portfolio transitions to third-party implemented and implementers take on more of the marketing efforts of their respective programs.
		Account Management / Sales	\$0.2	\$0.2	\$0.0	Immaterial.
		IT	\$4.7	\$4.3	-\$0.4	Decrease due to lower O&M costs and reduction in discretionary project spend.
		Call Center	\$0.0	\$0.0	\$0.0	Immaterial.
		EM&V	\$13.2	\$8.4	-\$4.8	EM&V budgets are set at 4% and spend typically occurs in future years.
		Facilities				Included in Labor.

Sector	Cost Element	Functional Group	2019 EE Expenditures (\$Million)	2021 EE Budget (\$Million)	Difference	Drivers
		Incentives--(PA-Implemented and Other Contracts Program Implementation) Programs	\$100.8	\$25.4	-\$75.4	Reduced existing programs' contracts & incentives spend to make room for new third-party and statewide contracts.
		Incentives--Third Party Program (as defined per D.16-08-019, OP 10)	\$9.6	\$29.1	\$19.4	N/A as these are outsourced costs and the question asks for drivers of in-house costs.
	Non-Labor Total		\$241.4	\$178.6	-\$62.7	
Total			\$287.0	\$220.7	-\$66.2	
	Other (collected through GRC) (2)	Labor Overheads	\$6.4	\$6.0	-\$0.4	2021 benefits burden amount represents estimated 2021 benefit burden expenditures. This estimate is calculated based on 2019 expenditures, reduction in 2021 FTEs forecast from 2019 FTEs, and 3% forecast inflation. The actual amount may differ based on the Benefit Burden decision rendered in the GRC proceeding.

Notes: (1) Labor costs are already loaded with employee benefits costs.

(2) These costs are collected in the EE balancing account but are litigated in the GRC Decision (D.17-05-013) - Decision Authorizing Pacific Gas and Electric Company's General Rate Case Revenue Requirement for 2017-2019, issue date of May 11, 2017. The 2020-2022 GRC Decision is still pending at the time of this filing.

**PG&E 2021 ABAL Attachment 3: Supplemental Budget Information**

**Appendix I.B.  
Energy Efficiency “Full Time Equivalent” Headcount:  
Portfolio Staffing**

Functional Group	2019 EE Portfolio FTE	2021 EE Portfolio FTE
Policy, Strategy, and Regulatory Reporting Compliance	35.1	33.1
Program Management	68.4	57.7
Engineering Services	38.6	37.6
Customer Application/Rebate/Incentive Processing	22.8	15.6
Customer Project Inspections	5.4	3.9
Portfolio Analytics	7.1	5.6
EM&V	7.0	6.1
ME&O	11.1	10.6
Account Management / Sales	63.6	56.7
IT	41.2	31.2
Call Center	1.6	1.7
<b>Total</b>	<b>301.8</b>	<b>259.7</b>

(1) 2021 FTEs were calculated based on the change in labor costs between 2019 and 2021 (adjusted for a 3% escalation/year) and applying that change to 2019 FTEs.

**PG&E 2021 ABAL Attachment 3: Supplemental Budget Information**

**Appendix I.C.  
Costs by Functional Area of Management Structure**

FUNCTION DEFINITIONS  
RESIDENTIAL BUDGET DETAIL  
COMMERCIAL BUDGET DETAIL  
AGRICULTURAL BUDGET DETAIL  
INDUSTRIAL BUDGET DETAIL  
PUBLIC SECTOR BUDGET DETAIL  
CROSS-CUTTING BUDGET DETAIL.

Aggregated Category	Definition	Functional Category	Detailed Definition
Policy, Strategy, and Regulatory Reporting Compliance	Includes policy, strategy, compliance, audits and regulatory support	Planning & Compliance	Demand Side Management (DSM) Goal Planning; lead legislative review/positioning; policy support on reg proceedings; portfolio optimization; end use-market strategy; DSM lead for PRP, DRP, ES; locational targeting; audit support; Sarbanes-Oxley (SOX) certifications; developing control plans; developing action plans; continuous monitoring; inspections; program/product QA/QC; decision compliance oversight/tracking; data requests; policies & procedures
		Company Regulatory Support	Case management for EE proceedings
Program management	Includes labor, contracts, admin costs for program design, program implementation, product and channel management for all sectors	Program Management & Delivery	Market Segment & Locational Resource programs; Business Core & Finance Programs; Large Power DR Programs; Non-Residential Heating, Ventilation, Air Conditioning (HVAC) & Technical Services; Program Integration & Optimization; Residential EE & Demand Response (DR) Programs (incl. Res HVAC Quality Installation); IQP & Economic Assistance Programs; Mass Market DR Programs; Education & Information Products & Services; Energy Leader Partnerships; Institutional & Federal Partnerships; REN Coordination; Strategic Plan Support; Energy/Water Program Management; Service Level Agreement Tracking
		Product Management	Manage end-to-end new products and services (P&S) intake, evaluation, and launch process; develop and facilitate P&S governance teams, coordination of all sub-process owners, stakeholders, and technical resources required to evaluate and launch new products; evaluate and launch new services and OOR opportunities; develop external partnerships & strategic alliances; work with various companies and associations to help advance standards, products, and tech.; work with external experts to help reduce SCE costs to deliver new prog. and products; develop and launch new customer technologies, products, services for residential and business customers; conduct customer pilots of new technologies and programs; lead customer field demonstrations of new technologies and products; align new P&S to savings programs/incentives; develop new programs/incentives in support of savings goals
		Channel Management	
		Contract Management	Budget forecasting, spend tracking, invoice processing, and contract management with vendors and suppliers; Regulatory support for ME&O activities
Engineering Services	Includes engineering, project management, and contracts associated with workpaper development and pre/post sales project technical reviews and design assistance	Custom project support	Management of Emerging Products projects; Customized reviews; LCR/RFO support; Ex-ante review management; Technical policy support; Technical assessments; Workpapers; Tool development; End use subject matter expertise
		Deemed workpapers	
		Project management	



Aggregated Category	Definition	Functional Category	Detailed Definition
Customer Application/Rebate and Incentive Processing	Costs associated with application management and rebate and incentive processing (deemed and custom)	Rebate & Application Processing	
Inspections	Costs associated with project inspections	Inspections	
Portfolio Analytics	Includes analytics support, including internal performance reporting and external reporting	Data analytics	Data development for programs, products and services; Standard and ad hoc data extracts for internal and external clients; Database management; CPUC, CAISO reporting; Data reconciliation; E3 support; Compliance filing support; Funding Oversight; ESPI support; Program Results Data & Performance
EM&V	EM&V expenditures	EM&V Studies	Program and product review; manage evaluation studies
		EM&V Forecasting	EE lead for LTPP and IEPR; market potential study; integration w/ procurement planning; CPUC Demand Analysis Working Group
ME&O	Costs associated with utility EE marketing; no statewide; focus on outsourced portion	Marketing	Customer Programs, Products, and Services Marketing; Digital Product Development; Digital Content & Optimization
		Customer insights	Voice of the Customer; Customer satisfaction study measurement and analysis (JD Power, SDS); Customer testing/research
Account Management / Sales	Costs associated with account rep energy efficiency sales functions	Account Management	
IT	IT project specific costs and regular O&M	IT - project specific	Projects and minor enhancements. Includes project management/business integration ("PMO/BID"). Excluded: maintenance (which SCE defines as when something goes down, normal batch processing, verifying interfaces, etc.).
		IT – regular operations & maintenance	
Call Center	Costs associated with call center staff fielding EE program questions	Call Center	
Incentives	Costs of rebate and incentive payments to customers	Incentives	

Sector	Cost Element	Functional Group	2019 EE Portfolio Expenditures (\$Million)	2021 EE Portfolio Budget (\$Million)	
Residential	Labor (1)	Policy, Strategy, and Regulatory Reporting Compliance	\$1.6	\$1.0	
		Program Management	\$2.7	\$2.3	
		Engineering services	\$0.5	\$0.3	
		Customer Application/Rebate/Incentive Processing	\$0.4	\$0.2	
		Customer Project Inspections	\$0.3	\$0.1	
		Portfolio Analytics	\$0.4	\$0.2	
		ME&O (Local)	\$0.8	\$1.0	
		Account Management / Sales	\$0.0	\$0.0	
		IT	\$1.3	\$1.1	
		Call Center	\$0.4	\$0.1	
	Labor Total			\$8.4	\$6.3
	Non-Labor	Third-Party Implementer (as defined per D.16-08-019, OP 10)		\$1.7	\$26.8
		Local/Government Partnerships Contracts		\$0.0	\$0.0
		Other Contracts			
		Program Implementation		\$15.1	\$1.9
		Policy, Strategy, and Regulatory Reporting Compliance		\$0.2	\$0.3
		Program Management		\$0.8	\$0.5
		Engineering services		\$0.6	\$0.2
		Customer Application/Rebate/Incentive Processing		\$0.1	\$0.0
		Customer Project Inspections		\$0.0	\$0.0
		Portfolio Analytics		\$0.0	\$0.0
		ME&O (Local)		\$2.1	\$2.2
		Account Management / Sales		\$0.0	\$0.0
		IT		\$1.6	\$1.3
		Call Center		\$0.0	\$0.0
		Facilities		\$0.0	\$0.0
		Incentives--(PA-implemented and Other Contracts Program Implementation) Programs		\$48.5	\$4.8
		Incentives--Third Party Program (as defined per D.16-08-019, OP 10)		\$10.0	\$5.5
Non-Labor Total			\$80.7	\$43.6	
Residential Total			\$89.1	\$49.9	
	Other (litigated through GRC) (2)	Labor Overheads	\$1.2	\$0.9	

Notes: (1) Labor costs are already loaded with employee benefits costs.

(2) These costs are collected in the EE balancing account but are litigated in the GRC Decision (D.17-05-013) - Decision Authorizing Pacific Gas and Electric Company's General Rate Case Revenue Requirement for 2017-2019, issue date of May 11, 2017. The 2020-2022 GRC Decision is still pending at the time of this filing.

Sector	Cost Element	Functional Group	2019 EE Portfolio Expenditures (\$Million)	2021 EE Portfolio Budget (\$Million)
--------	--------------	------------------	--	--------------------------------------

Commercial	Labor(1)	Policy, Strategy, and Regulatory Reporting Compliance	\$0.7	\$0.8	
		Program Management	\$2.4	\$2.3	
		Engineering services	\$2.4	\$2.0	
		Customer Application/Rebate/Incentive Processing	\$0.5	\$0.2	
		Customer Project Inspections	\$0.4	\$0.3	
		Portfolio Analytics	\$0.3	\$0.2	
		ME&O (Local)	\$1.2	\$0.8	
		Account Management / Sales	\$3.3	\$2.3	
		IT	\$1.1	\$0.7	
		Call Center	\$0.0	\$0.1	
		Labor Total		\$12.2	\$9.5
	Non-Labor	Third-Party Implementer (as defined per D.16-08-019, OP 10)	\$0.3	\$19.4	
		Local/Government Partnerships Contracts (3)	\$0.0	\$0.0	
		Other Contracts			
		Program Implementation	\$19.3	\$1.0	
		Policy, Strategy, and Regulatory Reporting Compliance	\$0.2	\$0.3	
		Program Management	\$0.5	\$0.4	
		Engineering services	\$2.6	\$1.6	
		Customer Application/Rebate/Incentive Processing	\$0.0	\$0.0	
		Customer Project Inspections	\$0.0	\$0.0	
		Portfolio Analytics	\$0.0	\$0.0	
		ME&O (Local)	\$2.3	\$1.1	
		Account Management / Sales	\$0.1	\$0.0	
		IT	\$1.2	\$0.8	
		Call Center	\$0.0	\$0.0	
		Facilities	\$0.0	\$0.0	
		Incentives--(PA-implemented and Other Contracts Program Implementation) Programs	\$28.6	\$6.5	
Incentives--Third Party Program (as defined per D.16-08-019, OP 10)	\$0.0	\$15.9			
Non-Labor Total		\$55.1	\$47.1		
Commercial Total		\$67.3	\$56.6		
	Other (litigated through GRC) (2)	Labor Overheads	\$1.8	\$1.4	

- Notes: (1) Labor costs are already loaded with employee benefits costs.  
(2) These costs are collected in the EE balancing account but are litigated in the GRC Decision (D.17-05-013) - Decision Authorizing Pacific Gas and Electric Company's General Rate Case Revenue Requirement for 2017-2019, issue date of May 11, 2017. The 2020-2022 GRC Decision is still pending at the time of this filing.

Sector	Cost Element	Functional Group	2019 EE Portfolio Expenditures (\$Million)	2021 EE Portfolio Budget (\$Million)
Industrial	Labor (1)	Policy, Strategy, and Regulatory Reporting Compliance	\$0.2	\$0.6
		Program Management	\$1.0	\$1.1

	Engineering services		\$1.0	\$1.7
	Customer Application/Rebate/Incentive Processing		\$0.1	\$0.1
	Customer Project Inspections		\$0.0	\$0.1
	Portfolio Analytics		\$0.1	\$0.2
	ME&O (Local)		\$0.1	\$0.1
	Account Management / Sales		\$1.7	\$3.1
	IT		\$0.6	\$0.5
	Call Center		\$0.0	\$0.1
	<b>Labor Total</b>		<b>\$4.8</b>	<b>\$7.5</b>
Non-Labor	Third-Party Implementer (as defined per D.16-08-019, OP 10)		\$0.2	\$5.1
	Local/Government Partnerships Contracts (3)		\$0.0	\$0.0
	Other Contracts			
	Program Implementation		\$11.9	\$3.8
	Policy, Strategy, and Regulatory Reporting Compliance		\$0.1	\$0.2
	Program Management		\$0.2	\$0.3
	Engineering services		\$0.7	\$0.8
	Customer Application/Rebate/Incentive Processing		\$0.0	\$0.0
	Customer Project Inspections		\$0.0	\$0.0
	Portfolio Analytics		\$0.0	\$0.0
	ME&O (Local)		\$0.2	\$0.1
	Account Management / Sales		\$0.0	\$0.1
	IT		\$0.5	\$0.6
	Call Center		\$0.0	\$0.0
	Facilities		\$0.0	\$0.0
	Incentives--(PA-implemented and Other Contracts Program Implementation) Programs		\$6.5	\$6.5
Incentives--Third Party Program (as defined per D.16-08-019, OP 10) (3)		-\$0.4	\$3.9	
	<b>Non-Labor Total</b>		<b>\$19.9</b>	<b>\$21.4</b>
	<b>Industrial Total</b>		<b>\$24.7</b>	<b>\$28.9</b>
	Other (litigated through GRC) (2)	Labor Overheads	\$0.7	\$1.1

- Notes:
- (1) Labor costs are already loaded with employee benefits costs.
  - (2) Negative incentives primarily represent a reversal of an accrual from the previous year.
  - (3) These costs are collected in the EE balancing account but are litigated in the GRC Decision (D.17-05-013) - Decision Authorizing Pacific Gas and Electric Company's General Rate Case Revenue Requirement for 2017-2019, issue date of May 11, 2017. The 2020-2022 GRC Decision is still pending at the time of this filing.

Sector	Cost Element	Functional Group	2019 EE Portfolio Expenditures (\$Million)	2021 EE Portfolio Budget (\$Million)	
Agricultural	Labor(1)	Policy, Strategy, and Regulatory Reporting Compliance	\$0.1	\$0.3	
		Program Management	\$0.6	\$0.5	
		Engineering services	\$0.8	\$0.6	
		Customer Application/Rebate/Incentive Processing	\$0.1	\$0.1	
		Customer Project Inspections	\$0.0	\$0.1	
		Portfolio Analytics	\$0.1	\$0.1	
		ME&O (Local)	\$0.1	\$0.1	
		Account Management / Sales	\$1.1	\$1.3	
		IT	\$0.4	\$0.2	
		Call Center	\$0.0	\$0.0	
	Labor Total			\$3.3	\$3.3
	Non-Labor	Third-Party Implementer (as defined per D.16-08-019, OP 10)		\$0.1	\$2.5
		Local/Government Partnerships Contracts (3)		\$0.0	\$0.0
		Other Contracts			
		Program Implementation		\$1.3	\$0.0
		Policy, Strategy, and Regulatory Reporting Compliance		\$0.1	\$0.1
		Program Management		\$0.2	\$0.2
		Engineering services		\$0.5	\$0.2
		Customer Application/Rebate/Incentive Processing		\$0.0	\$0.0
		Customer Project Inspections		\$0.0	\$0.0
		Portfolio Analytics		\$0.0	\$0.0
		ME&O (Local)		\$0.3	\$0.2
		Account Management / Sales		\$0.0	\$0.0
		IT		\$0.3	\$0.3
		Call Center		\$0.0	\$0.0
		Facilities		\$0.0	\$0.0
		Incentives--(PA-implemented and Other Contracts Program Implementation) Programs		\$4.9	\$4.7
Incentives--Third Party Program (as defined per D.16-08-019, OP 10)		\$0.0	\$2.4		
Non-Labor Total			\$7.6	\$10.6	
Agricultural Total			\$10.9	\$13.9	
	Other (litigated through GRC) (2)	Labor Overheads	\$0.5	\$0.5	

Notes: (1) Labor costs are already loaded with employee benefits costs.  
(2) These costs are collected in the EE balancing account but are litigated in the GRC Decision (D.17-05-013) - Decision Authorizing Pacific Gas and Electric Company's General Rate Case Revenue Requirement for 2017-2019, issue date of May 11, 2017. The 2020-2022 GRC Decision is still pending at the time of this filing.

Sector	Cost Element	Functional Group	2019 EE Portfolio Expenditures (\$Million)	2021 EE Portfolio Budget (\$Million)	
Public	Labor(1)	Policy, Strategy, and Regulatory Reporting Compliance	\$0.6	\$0.3	
		Program Management	\$2.6	\$1.4	
		Engineering services	\$0.2	\$0.2	
		Customer Application/Rebate/Incentive Processing	\$0.1	\$0.1	
		Customer Project Inspections	\$0.0	\$0.0	
		Portfolio Analytics	\$0.2	\$0.1	
		ME&O (Local)	\$0.1	\$0.0	
		Account Management / Sales	\$2.2	\$1.5	
		IT	\$0.9	\$0.3	
		Call Center	\$0.0	\$0.0	
	Labor Total			\$6.8	\$4.0
	Non-Labor	Third-Party Implementer (as defined per D.16-08-019, OP 10)		\$0.0	\$5.2
		Local/Government Partnerships Contracts		\$11.6	\$0.0
		Other Contracts			
		Program Implementation		\$8.6	\$1.9
		Policy, Strategy, and Regulatory Reporting Compliance		\$0.2	\$0.1
		Program Management		\$0.3	\$0.2
		Engineering services		\$0.3	\$0.2
		Customer Application/Rebate/Incentive Processing		\$0.0	\$0.0
		Customer Project Inspections		\$0.0	\$0.0
		Portfolio Analytics		\$0.0	\$0.0
		ME&O (Local)		\$0.2	\$0.0
		Account Management / Sales		\$0.0	\$0.0
		IT		\$0.9	\$0.3
		Call Center		\$0.0	\$0.0
		Facilities		\$0.0	\$0.0
		Incentives--(PA-implemented and Other Contracts Program Implementation) Programs		\$12.2	\$2.8
Incentives--Third Party Program (as defined per D.16-08-019, OP 10)		\$0.0	\$1.4		
Non-Labor Total			\$34.3	\$12.2	
Public Total			\$41.1	\$16.1	
	Other (litigated through GRC) (2)	Labor Overheads	\$0.9	\$0.6	

Notes: (1) Labor costs are already loaded with employee benefits costs.  
(2) These costs are collected in the EE balancing account but are litigated in the GRC Decision (D.17-05-013) - Decision Authorizing Pacific Gas and Electric Company's General Rate Case Revenue Requirement for 2017-2019, issue date of May 11, 2017. The 2020-2022 GRC Decision is still pending at the time of this filing.

Sector	Cost Element	Functional Group	2019 EE Portfolio Expenditures (\$Million)	2021 EE Portfolio Budget (\$Million)	
Cross-cutting	Labor (1)	Policy, Strategy, and Regulatory Reporting Compliance	\$0.7	\$0.9	
		Program Management	\$4.4	\$4.7	
		Engineering services	\$1.6	\$1.9	
		Customer Application/Rebate/Incentive Processing	\$0.7	\$0.7	
		Customer Project Inspections	\$0.0	\$0.0	
		Portfolio Analytics	\$0.2	\$0.2	
		ME&O (Local)	\$0.2	\$0.5	
		Account Management / Sales	\$0.9	\$0.4	
		IT	\$0.1	\$0.8	
	Call Center	\$0.0	\$0.1		
	Labor Total			\$8.8	\$10.3
	Non-Labor	Third-Party Implementer (as defined per D.16-08-019, OP 10)		\$12.8	\$8.3
		Local/Government Partnerships Contracts		\$0.0	\$0.0
		Other Contracts			
		Program Implementation		\$13.8	\$22.4
		Policy, Strategy, and Regulatory Reporting Compliance		\$0.1	\$0.3
		Program Management		\$0.7	\$0.6
		Engineering services		\$2.1	\$1.7
		Customer Application/Rebate/Incentive Processing		\$0.1	\$0.1
		Customer Project Inspections		\$0.0	\$0.0
		Portfolio Analytics		\$0.0	\$0.0
		ME&O (Local)		\$0.7	\$1.0
		Account Management / Sales		\$0.0	\$0.0
		IT		\$0.3	\$0.9
		Call Center		\$0.0	\$0.0
		Facilities		\$0.0	\$0.0
	Incentives--(PA-implemented and Other Contracts Program Implementation) Programs		\$0.0	\$0.0	
Incentives--Third Party Program (as defined per D.16-08-019, OP 10)		\$0.0	\$0.0		
Non-Labor Total			\$30.5	\$35.4	
Cross-cutting Total			\$39.3	\$45.7	
	Other (litigated through GRC) (2)	Labor Overheads	\$1.3	\$1.5	

Notes: (1) Labor costs are already loaded with employee benefits costs.  
(2) These costs are collected in the EE balancing account but are litigated in the GRC Decision (D.17-05-013) - Decision Authorizing Pacific Gas and Electric Company's General Rate Case Revenue Requirement for 2017-2019, issue date of May 11, 2017. The 2020-2022 GRC Decision is still pending at the time of this filing.

**PG&E 2021 ABAL Attachment 3: Supplemental Budget Information**

**Appendix II.A.  
Question C-8:  
Portfolio Summary**

Sector	2019 EE Portfolio Expenditures (\$Million)				2021 EE Portfolio Budget (\$Million)				2019 EE Portfolio Savings			2021 EE Portfolio Forecasted Savings		
	Labor	Non-Labor (excl. Incentives)	Incentives	Total	Labor	Non-Labor (excl. Incentives)	Incentives	Total	KWH	KW	M THERMS	KWH	KW	M THERMS
Residential	\$8.4	\$22.2	\$58.5	\$89.1	\$6.3	\$33.3	\$10.3	\$49.9	319,006,980	53,794	4.6	178,135,896	44,668	6.8
Commercial	\$12.2	\$26.5	\$28.6	\$67.3	\$9.5	\$24.7	\$22.4	\$56.6	95,775,512	18,860	2.0	90,210,572	12,868	3.7
Agricultural	\$3.3	\$2.7	\$4.9	\$10.9	\$3.3	\$3.5	\$7.1	\$13.9	18,135,463	6,478	0.1	17,782,872	3,962	0.1
Industrial	\$4.8	\$13.9	\$6.0	\$24.7	\$7.5	\$11.0	\$10.4	\$28.9	18,362,190	1,325	5.4	47,017,763	4,031	3.4
Public (GP)	\$6.8	\$22.0	\$12.2	\$41.1	\$4.0	\$8.0	\$4.2	\$16.1	50,057,650	6,837	0.0	14,775,962	1,701	0.2
Cross Cutting*	\$8.8	\$30.5	\$0.0	\$39.3	\$10.3	\$35.4	\$0.0	\$45.7	748,297,203	165,187	15.2	1,023,053,958	220,550	14.6
<b>Total Sector Budget</b>	<b>\$44.3</b>	<b>\$117.8</b>	<b>\$110.4</b>	<b>\$272.5</b>	<b>\$40.9</b>	<b>\$115.9</b>	<b>\$54.4</b>	<b>\$211.2</b>	<b>1,249,634,998</b>	<b>252,480</b>	<b>27.3</b>	<b>1,370,977,024</b>	<b>287,780</b>	<b>28.8</b>
DSM	\$0.0	\$0.0	\$0.0	\$0.0	\$0.0	\$0.0	\$0.0	\$0.0	n/a	n/a	n/a	n/a	n/a	n/a
EM&V-PA	\$1.2	\$1.2	\$0.0	\$2.5	\$1.1	\$1.9	\$0.0	\$3.0	n/a	n/a	n/a	n/a	n/a	n/a
EM&V-ED	\$0.0	\$11.9	\$0.0	\$11.9	\$0.0	\$6.5	\$0.0	\$6.5	n/a	n/a	n/a	n/a	n/a	n/a
OBF - Loan Pool	\$0.0	\$0.0	\$31.1	\$31.1	\$0.0	\$0.0	\$17.0	\$17.0	n/a	n/a	n/a	n/a	n/a	n/a
<b>EE Total</b>	<b>\$45.6</b>	<b>\$131.0</b>	<b>\$141.4</b>	<b>\$318.0</b>	<b>\$42.1</b>	<b>\$124.2</b>	<b>\$71.4</b>	<b>\$237.7</b>	<b>n/a</b>	<b>n/a</b>	<b>n/a</b>	<b>n/a</b>	<b>n/a</b>	<b>n/a</b>

\* Cross Cutting Sector includes Codes & Standards, Emerging Technologies, Workforce Education & Training, Financing.



PG&E 2021 ABAL Attachment 3: Supplemental Budget Information

Appendix II.C.

Question C-10:

Aggregate Budgets for Statewide Programs  
EE Programs Solicitation Strategy

Joint IOU Energy Efficiency Solicitation Timeline

Schedule as of 7/30/2020 (Schedule may be subject to change at IOU's discretion)

IOU	Year		2019												2020												2021											
	Quarter		Q1			Q2			Q3			Q4			Q1			Q2			Q3			Q4			Q1			Q2			Q3			Q4		
	Month		Jan	Feb	Mar	Apr	May	Jun	Jul	Aug	Sep	Oct	Nov	Dec	Jan	Feb	Mar	Apr	May	Jun	Jul	Aug	Sep	Oct	Nov	Dec	Jan	Feb	Mar	Apr	May	Jun	Jul	Aug	Sep	Oct	Nov	Dec
PG&E	Local Customer Programs	Residential Sector	RFA	RFP Prep			RFP			Contract Negotiation																												
PG&E		Commercial Sector		RFP Prep			RFP			Contract Negotiation																												
PG&E		Industrial Sector		RFP Prep			RFP			Contract Negotiation																												
PG&E		Agricultural Sector		RFP Prep			RFP			Contract Negotiation																												
PG&E		Public Sector		RFP Prep			RFP			Contract Negotiation																												
PG&E	Statewide Programs PG&E Lead	New Construction	RFA Prep		RFA		RFP Prep			RFP			Contract Negotiation																									
PG&E		WE&T Career and Workforce Readiness	RFA Prep			RFA		RFP Prep		RFP		Contract Negotiation																										
PG&E		WE&T K-12 Connections	RFA Prep			RFA		RFP Prep		RFP		Contract Negotiation																										
PG&E		State of CA / Dept. of Corrections	RFA Prep			RFA		RFP Prep		RFP		Contract Negotiation																										
PG&E		Codes & Standards Appliances	RFP Prep			RFP		Contract Negotiation																														
PG&E	Ad-Hoc Targeted Solicitations	LGP Non-Resource	RFA Prep		RFA		RFP Prep		RFP		Contract Negotiation																											

# **Attachment 4**

## **Appendices**

## PG&E 2021 ABAL Attachment 4 Appendix Tables

All Attachment 4 Appendix Tables are downloadable on PG&E's 2021 Budget Filing dashboard on CEDARS.

<b>Appendix Table Number</b>	<b>Location in Filing Materials</b>
Tables 1 – 8	Included in this attachment.
Table 9	Included as Table 1 of the advice letter.
Table 10	Included in this attachment.
Tables 11 – 18 (and Functions Definitions table)	Included in Attachment 3 for Supplemental Budget Information.
Table 19	Included in this attachment.

**Attachment 4, Table 1**

**PA Name:** Pacific Gas and Electric Company

**Budget Year:** 2021

<b>Table 1 -Bill Payer Impacts - Rates by Customer Class</b>				
	<b>Electric Average Rate (Res and Non-Res) \$/kwh</b>	<b>Gas Average Rate (Non-CARE Residential) \$/therm</b>	<b>Total Average Bill Savings by Year (\$)</b>	<b>Total Average Lifecycle Bill Savings (\$)</b>
<b>Present Rates - System Average</b>				
2018	\$ 0.19545	\$ 1.53810	\$ 296,725,167	\$ 3,461,239,273
2019	\$ 0.20701	\$ 1.56836	\$ 301,462,245	\$ 3,456,129,207
2020	\$ 0.22169	\$ 1.68169	\$ 274,428,669	\$ 3,129,687,409
2021*	\$ 0.22213	\$ 1.67328	\$ 352,761,643	\$ 3,974,867,028

\* = Based on current effective rates

Notes

- 1) Average first year electric bill savings is calculated by multiplying an average electric rate with first year net kWh energy savings.
- 2) Average first year gas bill savings is calculated by multiplying an average gas rate with first year net therm energy savings.
- 3) Total average first year bill savings is the sum of Notes 1 and 2.
- 4) Average lifecycle electric bill savings is calculated by multiplying an average electric rate with lifecycle net kWh energy savings.
- 5) Average lifecycle gas bill savings is calculated by multiplying an average gas rate with lifecycle net therm energy savings.
- 6) Total average lifecycle bill savings is the sum of Notes 4 and 5.
- 7) As of 5/1/2020, the bundled average electric rate is \$0.22169
- 8) As of 8/1/2020, the bundled average gas rate is \$1.6656 per therm before the impact of EE programs.
- 9) Total Average Bill Savings by Year and Lifecycle Bill Savings include C&S net lifecycle savings and exclude ESA Programs.
- 10) Consistent with SPM TRC/PAC/RIM tests, all savings used from actuals and forecasts in this table are net not gross
- 11) 2018 and 2019 estimated bill savings are based on energy savings from program year annual reports, and 2020 and 2021 estimated bill savings are based on the 2020 and 2021 ABAL forecasts.

Table 2a - Electric Bill Payer Impacts - Current and Proposed Revenues and Rates, Total and Energy Efficiency, by Customer Class

Customer Classes	2019 Energy Efficiency Electric Annual Revenue Change \$000	2019 Percentage Change In Electric Revenues	2019 Electric Average Rate \$/kwh	2019 Energy Efficiency Portion of Electric Average Rate \$/kwh	2020 Energy Efficiency Electric Annual Revenue Change \$000	2020 Percentage Change In Electric Revenues	2020 Electric Average Rate \$/kwh	2021 Proposed Energy Efficiency Electric Annual Revenue Change \$000	2021 Proposed Percentage Change In Electric Revenues	2021 Electric Average Rate \$/kWh	2021 Energy Efficiency Portion of Electric Average Rate \$/kWh
<b>Bundled</b>											
Residential	\$ 73,572	2.3%	\$ 0.21522	\$ 0.00488	\$ 35,082	1.1%	\$ 0.22913	\$ 7,132	0.2%	\$ 0.22976	\$ 0.00304
Commercial - Small	\$ 20,179	2.2%	\$ 0.24953	\$ 0.00532	\$ 8,713	1.1%	\$ 0.26618	\$ 1,771	0.2%	\$ 0.26627	\$ 0.00334
Commercial - Medium	\$ 14,730	2.0%	\$ 0.22316	\$ 0.00434	\$ 6,966	1.0%	\$ 0.23721	\$ 1,416	0.2%	\$ 0.23740	\$ 0.00271
Commercial - Large	\$ 17,372	2.0%	\$ 0.19801	\$ 0.00383	\$ 8,377	1.0%	\$ 0.20694	\$ 1,703	0.2%	\$ 0.20726	\$ 0.00238
Streetlights	\$ 720	2.1%	\$ 0.25842	\$ 0.00522	\$ 235	0.9%	\$ 0.30458	\$ 48	0.2%	\$ 0.30463	\$ 0.00325
Standby	\$ 1,431	2.9%	\$ 0.15881	\$ 0.00454	\$ 1,033	1.2%	\$ 0.18482	\$ 210	0.2%	\$ 0.18577	\$ 0.00271
Agricultural	\$ 18,001	1.9%	\$ 0.21202	\$ 0.00388	\$ 9,005	0.8%	\$ 0.25109	\$ 1,831	0.2%	\$ 0.25146	\$ 0.00235
Industrial	\$ 17,662	1.7%	\$ 0.15858	\$ 0.00272	\$ 8,926	0.8%	\$ 0.16657	\$ 1,815	0.2%	\$ 0.16696	\$ 0.00167
<b>Direct Access Service</b>											
Residential	\$ 63,999	3.2%	\$ 0.15968	\$ 0.00488	\$ 35,126	1.5%	\$ 0.17293	\$ 7,141	0.3%	\$ 0.17362	\$ 0.00304
Commercial - Small	\$ 23,561	3.5%	\$ 0.15903	\$ 0.00532	\$ 13,309	1.6%	\$ 0.17919	\$ 2,706	0.3%	\$ 0.17929	\$ 0.00334
Commercial - Medium	\$ 23,919	3.5%	\$ 0.12799	\$ 0.00434	\$ 11,914	1.5%	\$ 0.14831	\$ 2,422	0.3%	\$ 0.14850	\$ 0.00271
Commercial - Large	\$ 34,856	3.8%	\$ 0.10359	\$ 0.00383	\$ 18,340	1.7%	\$ 0.11757	\$ 3,728	0.3%	\$ 0.11788	\$ 0.00238
Streetlights	\$ 645	3.2%	\$ 0.16670	\$ 0.00522	\$ 427	1.6%	\$ 0.17360	\$ 87	0.3%	\$ 0.17365	\$ 0.00325
Standby	\$ 159	3.1%	\$ 0.15321	\$ 0.00454	\$ 111	1.4%	\$ 0.16453	\$ 23	0.3%	\$ 0.16524	\$ 0.00271
Agricultural	\$ 3,783	2.7%	\$ 0.14988	\$ 0.00388	\$ 2,021	1.2%	\$ 0.16531	\$ 411	0.2%	\$ 0.16567	\$ 0.00235
Industrial	\$ 26,304	4.1%	\$ 0.06828	\$ 0.00272	\$ 13,105	1.8%	\$ 0.07743	\$ 2,664	0.4%	\$ 0.07779	\$ 0.00168
<b>Departed Load</b>	\$ 6,360	25.2%			\$ 4,803	10.6%		\$ 976	2.0%		

\* 2020 total revenues from May 1, 2020 Rate Change as filed in AL 5661-E

\*\* Electric revenue requirements from Appendix Table 3c are reflected in this rate impact table.

Table 2b - Gas Bill Payer Impacts - Current and Proposed Revenues and Rates, Total and Energy Efficiency, by Customer Class

Customer Classes	2019 Energy Efficiency Gas Annual Revenue Change * \$000	2019 Percentage Change In Gas Revenue	2019 Gas Average Rate \$/therm	2019 Energy Efficiency Portion of Gas Average Rate \$/therm	2020 Energy Efficiency Gas Annual Revenue Change \$000	2020 Percentage Change In Gas Revenue	2020 Gas Average Rate \$/therm	2021 Proposed Energy Efficiency Gas Annual Revenue Change \$000	2021 Proposed Percentage Change In Gas Revenue	2021 Gas Average Rate \$/therm	2021 Energy Efficiency Portion of Gas Average Rate \$/therm
<b>Core Retail Bundled</b>											
Residential - Non-CARE	\$ 16,264	0.8%	\$ 1.5684	\$ 0.0127	\$ 3,986	0.2%	\$ 1.6817	\$ (10,833)	-0.5%	\$ 1.6733	\$ 0.0073
Residential - CARE	\$ 4,245	0.8%	\$ 1.2443	\$ 0.0127	\$ 1,040	0.2%	\$ 1.3247	\$ (2,828)	-0.5%	\$ 1.3163	\$ 0.0073
Commercial - Small	\$ 12,822	2.4%	\$ 1.0966	\$ 0.0293	\$ 3,142	0.6%	\$ 1.2146	\$ (8,540)	-1.5%	\$ 1.1953	\$ 0.0168
Commercial - Large	\$ 704	2.1%	\$ 0.7631	\$ 0.0197	\$ 173	0.6%	\$ 0.8316	\$ (469)	-1.5%	\$ 0.8187	\$ 0.0113
Commercial - Natural Gas Vehicle	\$ -	0.0%									
<b>Core Retail - Transportation Only</b>											
Residential - Non-CARE	\$ 1,951	1.1%	\$ 1.2533	\$ 0.0127	\$ 478	0.3%	\$ 1.3501	\$ (1,299)	-0.7%	\$ 1.3417	\$ 0.0073
Residential - CARE	\$ 509	1.1%	\$ 0.9292	\$ 0.0127	\$ 125	0.3%	\$ 0.9932	\$ (339)	-0.7%	\$ 0.9848	\$ 0.0073
Commercial - Small	\$ 9,483	3.7%	\$ 0.7979	\$ 0.0293	\$ 2,324	0.8%	\$ 0.9031	\$ (6,316)	-2.1%	\$ 0.8838	\$ 0.0168
Commercial - Large	\$ 613	3.7%	\$ 0.4932	\$ 0.0197	\$ 150	0.9%	\$ 0.5571	\$ (408)	-2.3%	\$ 0.5441	\$ 0.0113
Commercial - Natural Gas Vehicle	\$ -										
<b>Noncore- Transportation Only <sup>2</sup></b>											
Industrial - Distribution	\$ 7,344	8.2%	\$ 0.3761	\$ 0.0294	\$ 1,800	1.8%	\$ 0.3964	\$ (4,892)	-4.8%	\$ 0.3770	\$ 0.0169
Industrial - Transmission	\$ 13,830	5.7%	\$ 0.2011	\$ 0.0084	\$ 3,354	1.2%	\$ 0.2003	\$ (9,193)	-3.3%	\$ 0.1947	\$ 0.0049
Industrial - Backbone	\$ 112	15.6%	\$ 0.1071	\$ 0.0084	\$ 63	8.1%	\$ 0.0930	\$ (93)	-11.1%	\$ 0.0874	\$ 0.0049
Electric Generation		0.0%									
Natural Gas Vehicle		0.0%									
Wholesale		0.0%									
Unbundled Backbone and Storage		0.0%									
<b>Total Annual Revenue Requirement</b>	\$ 67,877	1.5%			\$ 16,636			\$ (45,210)			

\*2019 Energy Efficiency Revenues were allocated based on the adopted GCAP volumes (D. 19-10-036) in order to isolate the impacts of the change in Energy Efficiency Revenues only.

\*\* Gas revenue requirements from Appendix Table 3c are reflected in this rate impact table.

Attachment 4, Table 3  
 PA Name: Pacific Gas and Electric Company  
 Budget Year: 2021

Table 3a - Budget and Cost Recovery by Funding Source

	2021
2021 EE Portfolio Budget	\$ 274,557,408
Unspent/Uncommitted Program Carryover Funds from 2020	\$ 24,074,755
<b>Total Funding Request for 2021 EE Portfolio</b>	<b>\$ 250,482,654</b>

Table 3b - Budget by Funding Source [1]

2021 Authorized (Before Carryover)	2021 Budget	Allocation
Electric Procurement EE Funds	\$ 228,031,841	83.05%
Gas PPP Surcharge Funds	\$ 46,525,567	16.95%
<b>Total Funds</b>	<b>\$ 274,557,408</b>	<b>100%</b>

Table 3c - Revenue Requirement for Cost Recovery by Funding Source

2021 Authorized Funding in Rates (including carryover )	2021 Revenue Requirement	Allocation after Carryover adjustment
Electric Procurement EE Funds	\$ 211,179,513	84.3%
Gas PPP Surcharge Funds	\$ 39,303,141	15.7%
<b>Total Funds</b>	<b>\$ 250,482,654</b>	<b>100%</b>

Table 3d - Unspent/Uncommitted Carryover Funds (in positive \$ amonts)

Total Unspent/Uncommitted Funds	Electric PGC	Electric Procurement	Total Electric	Gas	Total
2020	\$ -	\$ 16,852,328	\$ 16,852,328	\$ 7,222,426	\$ 24,074,755
2018-2019	\$ -	\$ -	\$ -	\$ -	\$ -
<b>Total Pre-2021</b>	<b>\$ -</b>	<b>\$ 16,852,328</b>	<b>\$ 16,852,328</b>	<b>\$ 7,222,426</b>	<b>\$ 24,074,755</b>

EM&V Unspent/Uncommitted Funds [2]	Electric PGC	Electric Procurement	Total Electric	Gas	Total
2020	\$ -	\$ -	\$ -	\$ -	\$ -
2018-2019	\$ -	\$ -	\$ -	\$ -	\$ -
<b>Total Pre-2021</b>	<b>\$ -</b>	<b>\$ -</b>	<b>\$ -</b>	<b>\$ -</b>	<b>\$ -</b>

Program Unspent/Uncommitted Funds [2]	Electric PGC	Electric Procurement	Total Electric	Gas	Total
2020	\$ -	\$ 16,852,328	\$ 16,852,328	\$ 7,222,426	\$ 24,074,755
2018-2019	\$ -	\$ -	\$ -	\$ -	\$ -
<b>Total Pre-2021</b>	<b>\$ -</b>	<b>\$ 16,852,328</b>	<b>\$ 16,852,328</b>	<b>\$ 7,222,426</b>	<b>\$ 24,074,755</b>

[1] The electric and gas split for program year 2021 is forecasted to be 83%/17%, applicable to the portion of PG&E's EE portfolio budget that will not be supporting fuel substitution program activities. The portfolio budget that is forecasted to support fuel-substitution activities will be recovered 100% through electric rates only. See advice letter Section III.J.1., Table 15 for more details on the fuel-substitution budget. The resulting electric/gas split for the entire portfolio, including fuel-substitution activities, is 84.3% electric / 15.7% gas.

[2] Carryover for BayREN, 3C-REN, and MCE were taken from their respective 2021 ABAL presentations to CAEECC on August 5, 2020. Carryover from these presentations is assumed to include carryover from both 2019 and 2020, but the carryover estimates were not broken out by year. PG&E assumed the 2020 electric/gas split of 70%/30% for all carryover in the absence of more precise information. Final 2021 cost recovery amounts, including carryover broken out by program year and corresponding electric/gas split, will be filed by PG&E in a Tier 1 advice letter following the issuance of 2021 ABAL dispositions for PG&E, BayREN, 3C-REN, and MCE.

Attachment 4, Table 4  
PA Name: Pacific Gas and Electric Company  
Budget Year: 2021

Table 4 – Budget, Spent, Unspent, Carryover Details [1]

New/Existing Program #	Discontinued Program #	Main Program Name / Sub-Program Name	2020 Budget Spent as of 07/31/2020 [2]	2021 Proposed Budget	2021 Budget Offset (Expected 2020 Unspent/ Uncommitted and Any Remaining Pre-2020 Unspent/ Uncommitted Funding)	2021 Funds Requested	Program Type	New Business Sector
<b>Residential - Local</b>								
	PGE21001	Residential Energy Advisor [3]	\$ 12,197,688	\$ -	\$ -	\$ -	IOU Core/Statewide	Residential
	PGE21004	Energy Upgrade California [4]	\$ (73,923)	\$ -	\$ -	\$ -	IOU Core/Statewide	Residential
	PGE21006	Residential HVAC [4]	\$ 11,282	\$ -	\$ -	\$ -	IOU Core/Statewide	Residential
	PGE210010	Pay for Performance Pilot [3]	\$ 2,075,521	\$ -	\$ -	\$ -	Third/Local Party	Residential
PGE_Res_002a		Residential Energy Advisor - HEC	\$ -	\$ 2,165,909	\$ -	\$ 2,165,909	Third/Local Party	Residential
PGE_Res_002b		Residential Energy Advisor - Marketplace	\$ -	\$ 1,484,048	\$ -	\$ 1,484,048	Third/Local Party	Residential
PGE_Res_002c		Residential Energy Advisor - Home Energy Reports	\$ -	\$ 8,448,590	\$ -	\$ 8,448,590	Third/Local Party	Residential
PGE21002		Residential Energy Efficiency	\$ 2,071,758	\$ 949,405	\$ -	\$ 949,405	IOU Core/Statewide	Residential
PGE21005		Residential New Construction	\$ 2,434,092	\$ 3,937,257	\$ -	\$ 3,937,257	IOU Core/Statewide	Residential
PGE21007		California New Homes Multifamily	\$ 741,063	\$ 2,512,779	\$ -	\$ 2,512,779	Third/Local Party	Residential
PGE_Res_001a		Pay for Performance – Comfortable Home Rebates	\$ -	\$ 3,478,918	\$ -	\$ 3,478,918	Third/Local Party	Residential
PGE_Res_001b		Pay for Performance – Home Intel	\$ -	\$ 667,404	\$ -	\$ 667,404	Third/Local Party	Residential
PGE_Res_001c		Pay for Performance – Home Energy Rewards	\$ -	\$ 757,322	\$ -	\$ 757,322	Third/Local Party	Residential
PGE_Res_001d		Pay for Performance – Home Energy Optimization	\$ -	\$ 2,690,921	\$ -	\$ 2,690,921	Third/Local Party	Residential
PGE_Res_003		Multifamily Energy Savings Program	\$ -	\$ 4,168,929	\$ -	\$ 4,168,929	Third/Local Party	Residential
PGE_3P_Res		New Local 3P - Residential	\$ -	\$ 12,282,950	\$ -	\$ 12,282,950	Third/Local Party	Residential
<b>Residential - Statewide</b>								
PGE_SW_NC_Res		New Construction Residential	\$ -	\$ 2,413,152	\$ -	\$ 2,413,152	IOU Core/Statewide	Residential
PGE_SW_PLA		Plug Load and Appliance	\$ -	\$ 3,306,000	\$ -	\$ 3,306,000	IOU Core/Statewide	Residential
PGE_SW_NC_Res_PA		New Construction Residential PA Costs	\$ -	\$ 501,957	\$ -	\$ 501,957	IOU Core/Statewide	Residential
PGE_SW_PLA_PA		Plug Load and Appliance - PGE Costs	\$ -	\$ 163,126	\$ -	\$ 163,126	IOU Core/Statewide	Residential
<b>Commercial - Local</b>								
PGE21011		Commercial Calculated Incentives	\$ 3,440,061	\$ 6,598,323	\$ -	\$ 6,598,323	IOU Core/Statewide	Commercial
PGE211025		Savings by Design (SBD)	\$ 15,183	\$ 1,300,904	\$ -	\$ 1,300,904	IOU Core/Statewide	Commercial
PGE21012		Commercial Deemed Incentives	\$ 4,673,192	\$ 4,091,291	\$ -	\$ 4,091,291	IOU Core/Statewide	Commercial
PGE21014		Commercial Energy Advisor	\$ 866,299	\$ 1,355,344	\$ -	\$ 1,355,344	IOU Core/Statewide	Commercial
PGE210143		Hospitality Program	\$ 4,903,608	\$ 3,059,266	\$ -	\$ 3,059,266	Third/Local Party	Commercial
PGE_3P_Com		New 3P Placeholder - Commercial	\$ -	\$ 19,351,551	\$ -	\$ 19,351,551	Third/Local Party	Commercial
PGE_Com_001		Grocery Comprehensive Retrofit & Commissioning	\$ -	\$ 921,180	\$ -	\$ 921,180	Third/Local Party	Commercial
PGE_Com_002		Smart Labs	\$ -	\$ 731,411	\$ -	\$ 731,411	Third/Local Party	Commercial
<b>Commercial - Statewide</b>								
PGE_SW_FS		Food Service POS	\$ -	\$ 4,149,033	\$ -	\$ 4,149,033	IOU Core/Statewide	Commercial
PGE_SW_HVAC_Up		Upstream HVAC (Comm + Res)	\$ -	\$ 4,715,920	\$ -	\$ 4,715,920	IOU Core/Statewide	Residential
PGE_SW_MCWH		Midstream Comm Water Heating	\$ -	\$ 3,882,192	\$ -	\$ 3,882,192	IOU Core/Statewide	Commercial
PGE_SW_NC_NonRes		New Construction Non-Residential	\$ -	\$ 912,000	\$ -	\$ 912,000	IOU Core/Statewide	Commercial
PGE_SW_UL		Lighting (Upstream)	\$ -	\$ 3,552,000	\$ -	\$ 3,552,000	IOU Core/Statewide	Commercial
PGE_SW_FS_PA		Food Service POS - PGE Costs	\$ -	\$ 449,440	\$ -	\$ 449,440	IOU Core/Statewide	Commercial
PGE_SW_HVAC_Up_PA		Upstream HVAC (Comm + Res) - PGE Costs	\$ -	\$ 335,021	\$ -	\$ 335,021	IOU Core/Statewide	Residential
PGE_SW_MCWH_PA		Midstream Comm Water Heating - PGE Costs	\$ -	\$ 664,561	\$ -	\$ 664,561	IOU Core/Statewide	Commercial
PGE_SW_NC_NonRes_PA		New Construction Non-Residential PA Costs	\$ -	\$ 283,802	\$ -	\$ 283,802	IOU Core/Statewide	Commercial
PGE_SW_UL_PA		Lighting (Upstream) - PGE Costs	\$ -	\$ 272,503	\$ -	\$ 272,503	IOU Core/Statewide	Commercial
<b>Agricultural - Local</b>								
PGE_Ag_001		Agriculture Energy Savings Action Plan	\$ -	\$ 5,741,691	\$ -	\$ 5,741,691	Third/Local Party	Agricultural
PGE21031		Agricultural Calculated Incentives	\$ (358,080)	\$ 5,310,769	\$ -	\$ 5,310,769	IOU Core/Statewide	Agricultural
PGE21032		Agricultural Deemed Incentives	\$ 1,574,950	\$ 2,515,902	\$ -	\$ 2,515,902	IOU Core/Statewide	Agricultural

Attachment 4, Table 4  
PA Name: Pacific Gas and Electric Company  
Budget Year: 2021

Table 4 – Budget, Spent, Unspent, Carryover Details [1]

New/Existing Program #	Discontinued Program #	Main Program Name / Sub-Program Name	2020 Budget Spent as of 07/31/2020 [2]	2021 Proposed Budget	2021 Budget Offset (Expected 2020 Unspent/ Uncommitted and Any Remaining Pre-2020 Unspent/ Uncommitted Funding)	2021 Funds Requested	Program Type	New Business Sector
PGE21034		Agricultural Energy Advisor	\$ 537,781	\$ 278,369	\$ -	\$ 278,369	IOU Core/Statewide	Agricultural
PGE21036		Industrial Refrigeration Performance Plus	\$ 261	\$ 25,073	\$ -	\$ 25,073	Third/Local Party	Cross-Cutting
<b>Industrial - Local</b>								
	PGE21023	Industrial Continuous Energy Improvement [3]	\$ (0)	\$ -	\$ -	\$ -	IOU Core/Statewide	Industrial
	PGE21030	Industrial Strategic Energy Management [3]	\$ 734,094	\$ -	\$ -	\$ -	Third/Local Party	Industrial
PGE21021		Industrial Calculated Incentives	\$ 194,563	\$ 6,980,753	\$ -	\$ 6,980,753	IOU Core/Statewide	Industrial
PGE21022		Industrial Deemed Incentives	\$ 176,797	\$ 238,153	\$ -	\$ 238,153	IOU Core/Statewide	Industrial
PGE21024		Industrial Energy Advisor	\$ 186,302	\$ 286,526	\$ -	\$ 286,526	IOU Core/Statewide	Industrial
PGE210210		Industrial Recommissioning Program	\$ 404,379	\$ 1,505,303	\$ -	\$ 1,505,303	Third/Local Party	Industrial
PGE210212		Compressed Air and Vacuum Optimization Program	\$ 138,085	\$ 795,251	\$ -	\$ 795,251	Third/Local Party	Industrial
PGE21027		Heavy Industry Energy Efficiency Program	\$ 3,420,945	\$ 2,762,997	\$ -	\$ 2,762,997	Third/Local Party	Industrial
PGE_Ind_001a		Industrial Strategic Energy Management - Food Processing	\$ -	\$ 2,593,563	\$ -	\$ 2,593,563	Third/Local Party	Industrial
PGE_Ind_001b		Industrial Strategic Energy Management - Manufacturing	\$ -	\$ 3,124,098	\$ -	\$ 3,124,098	Third/Local Party	Industrial
PGE_Ind_002		Business Energy Performance Program	\$ -	\$ 5,934,442	\$ -	\$ 5,934,442	Third/Local Party	Industrial
PGE_Ind_003		Industrial Systems Optimization Program	\$ -	\$ 4,720,291	\$ -	\$ 4,720,291	Third/Local Party	Industrial
<b>Public - Local</b>								
PGE_Pub_009		Government & K-12 Comprehensive Program	\$ -	\$ 3,224,434	\$ -	\$ 3,224,434	Third/Local Party	Public
PGE_Pub_010		RAPIDS Wastewater Treatment Optimization Program	\$ -	\$ 629,350	\$ -	\$ 629,350	Third/Local Party	Public
PGE2110011		California Community Colleges	\$ 359,447	\$ 1,234,186	\$ -	\$ 1,234,186	State Institutional Partnership	Public
PGE2110012		University of California/California State University	\$ (1,800,458)	\$ 1,883,522	\$ -	\$ 1,883,522	State Institutional Partnership	Public
PGE2110013		State of California	\$ 37,338	\$ 624,642	\$ -	\$ 624,642	State Institutional Partnership	Public
PGE2110014		Department of Corrections and Rehabilitation	\$ (250,436)	\$ 807,589	\$ -	\$ 807,589	State Institutional Partnership	Public
PGE2110051		Local Government Energy Action Resources (LGEAR)	\$ 7,476,630	\$ 3,075,395	\$ -	\$ 3,075,395	Local Government Partnership	Public
<b>Public - Statewide</b>								
PGE_SW_IP_Gov		Institutional Partnerships: DGS & DoC	\$ -	\$ 190,000	\$ -	\$ 190,000	State Institutional Partnership	Public
PGE_SW_IP_Gov_PA		Institutional Partnerships: DGS & DoC - PGE Costs	\$ -	\$ 66,545	\$ -	\$ 66,545	State Institutional Partnership	Public
<b>Public LGP - Local</b>								
PGE_Pub_001		Central Coast Leaders in Energy Action Program	\$ 18,179	\$ 346,341	\$ -	\$ 346,341	Local Government Partnership	Public
PGE_Pub_002		Marin Energy Watch Partnership	\$ 16,119	\$ 277,907	\$ -	\$ 277,907	Local Government Partnership	Public
PGE_Pub_003		Redwood Coast Energy Watch	\$ 19,446	\$ 374,846	\$ -	\$ 374,846	Local Government Partnership	Public
PGE_Pub_004		Central California Energy Watch	\$ 54,781	\$ 800,802	\$ -	\$ 800,802	Local Government Partnership	Public
PGE_Pub_005		San Mateo County Energy Watch Program	\$ 28,554	\$ 448,606	\$ -	\$ 448,606	Local Government Partnership	Public
PGE_Pub_006		Energy Access SF	\$ 39,676	\$ 1,004,578	\$ -	\$ 1,004,578	Local Government Partnership	Public
PGE_Pub_007		Sierra Nevada Energy Watch	\$ 52,376	\$ 746,897	\$ -	\$ 746,897	Local Government Partnership	Public
PGE_Pub_008		Sonoma Public Energy	\$ 18,948	\$ 396,496	\$ -	\$ 396,496	Local Government Partnership	Public
<b>Financing - Local</b>								
PGE21092		Third-Party Financing [5]	\$ (361)	\$ -	\$ -	\$ -	IOU Core/Statewide	Cross-Cutting
PGE21093		New Financing Offerings [6]	\$ -	\$ -	\$ -	\$ -	IOU Core/Statewide	Cross-Cutting
PGE21091		On-Bill Financing (excludes Loan Pool)	\$ 2,669,950	\$ 1,168,076	\$ -	\$ 1,168,076	IOU Core/Statewide	Cross-Cutting
PGE210911		On-Bill Financing Alternative Pathway	\$ 262,641	\$ 4,030,576	\$ -	\$ 4,030,576	IOU Core/Statewide	Cross-Cutting
<b>Financing Loan Pool - Local</b>								
PGE21091LP		Financing Loan Pool Addition	\$ 14,648,574	\$ 17,000,000	\$ -	\$ 17,000,000	Non-Program	Cross-Cutting



Table 4 – Budget, Spent, Unspent, Carryover Details [1]

New/Existing Program #	Discontinued Program #	Main Program Name / Sub-Program Name	2020 Budget Spent as of 07/31/2020 [2]	2021 Proposed Budget	2021 Budget Offset (Expected 2020 Unspent/ Uncommitted and Any Remaining Pre-2020 Unspent/ Uncommitted Funding)	2021 Funds Requested	Program Type	New Business Sector
<b>Codes &amp; Standards - Local</b>								
	PGE21053	Compliance Improvement	\$ 3,485,412	\$ 5,524,990	\$ -	\$ 5,524,990	IOU Core/Statewide	Cross-Cutting
	PGE21054	Reach Codes	\$ 697,973	\$ 2,043,666	\$ -	\$ 2,043,666	IOU Core/Statewide	Cross-Cutting
	PGE21055	Planning and Coordination	\$ 917,271	\$ 740,393	\$ -	\$ 740,393	IOU Core/Statewide	Cross-Cutting
	PGE21056	Code Readiness	\$ 2,517,553	\$ 6,950,898	\$ -	\$ 6,950,898	IOU Core/Statewide	Cross-Cutting
<b>Codes &amp; Standards - Statewide</b>								
	PGE_SW_CSA_App	State Appliance Standards Advocacy	\$ 779,860	\$ 1,693,770	\$ -	\$ 1,693,770	IOU Core/Statewide	Cross-Cutting
	PGE_SW_CSA_Bldg	State Building Codes Advocacy	\$ 4,980,348	\$ 2,735,280	\$ -	\$ 2,735,280	IOU Core/Statewide	Cross-Cutting
	PGE_SW_CSA_Natl	National Codes & Standards Advocacy	\$ 1,821,722	\$ 1,569,630	\$ -	\$ 1,569,630	IOU Core/Statewide	Cross-Cutting
	PGE_SW_CSA_App_PA	State Appliance Standards Advocacy PA Costs	\$ 993,507	\$ 1,869,301	\$ -	\$ 1,869,301	IOU Core/Statewide	Cross-Cutting
	PGE_SW_CSA_Bldg_PA	State Building Codes Advocacy PA Costs	\$ 576,715	\$ 1,501,253	\$ -	\$ 1,501,253	IOU Core/Statewide	Cross-Cutting
	PGE_SW_CSA_Natl_PA	National Codes & Standards Advocacy PA Costs	\$ 103,581	\$ 624,637	\$ -	\$ 624,637	IOU Core/Statewide	Cross-Cutting
<b>Emerging Technology - Local</b>								
	PGE21062	Technology Assessments	\$ 720,193	\$ 1,460,138	\$ -	\$ 1,460,138	IOU Core/Statewide	Cross-Cutting
	PGE21063	Technology Introduction Support	\$ (16,112)	\$ 3,322,253	\$ -	\$ 3,322,253	IOU Core/Statewide	Cross-Cutting
<b>Emerging Technology - Statewide</b>								
	PGE_SW_ETP_Gas	Emerging Technologies Program, Gas	\$ -	\$ 1,512,000	\$ -	\$ 1,512,000	IOU Core/Statewide	Cross-Cutting
	PGE_SW_ETP_Gas_PA	Emerging Technologies Program, Gas - PGE Costs	\$ -	\$ 25,675	\$ -	\$ 25,675	IOU Core/Statewide	Cross-Cutting
<b>Workforce Ed. &amp; Training - Local</b>								
	PGE21071	Integrated Energy Education and Training	\$ 3,580,830	\$ 7,248,382	\$ -	\$ 7,248,382	IOU Core/Statewide	Cross-Cutting
	PGE21072	Connections	\$ 544,210	\$ 619,213	\$ -	\$ 619,213	IOU Core/Statewide	Cross-Cutting
<b>Workforce Ed. &amp; Training - Statewide</b>								
	PGE_SW_WET_CC	SW WET Career Connections	\$ -	\$ 266,000	\$ -	\$ 266,000	IOU Core/Statewide	Cross-Cutting
	PGE_SW_WET_Work	WE&T Career and Workforce Readiness	\$ -	\$ 561,943	\$ -	\$ 561,943	IOU Core/Statewide	Cross-Cutting
	PGE_SW_WET_CC_PA	SW WET Career Connections – PGE Costs	\$ -	\$ 106,802	\$ -	\$ 106,802	IOU Core/Statewide	Cross-Cutting
	PGE_SW_WET_Work_PA	WE&T Career and Workforce Readiness - PGE Costs	\$ -	\$ 140,704	\$ -	\$ 140,704	IOU Core/Statewide	Cross-Cutting
<b>Programs Discontinued in 2021 with 2020 Spending</b>								
	PGE21008	Enhance Time Delay Relay	\$ 1,103,160	\$ -	\$ -	\$ -	Third/Local Party	Residential
	PGE210011	Residential Energy Fitness Program	\$ (1,658,445)	\$ -	\$ -	\$ -	Third/Local Party	Residential
	PGE21003	Multifamily Energy Efficiency	\$ 536,362	\$ -	\$ -	\$ -	IOU Core/Statewide	Residential
	PGE21009	Direct Install for Manufactured and Mobile Homes	\$ 1,407,252	\$ -	\$ -	\$ -	Third/Local Party	Residential
	PGE210112	School Energy Efficiency	\$ 375,118	\$ -	\$ -	\$ -	Third/Local Party	Commercial
	PGE210123	Healthcare Energy Efficiency Program	\$ 132,339	\$ -	\$ -	\$ -	Third/Local Party	Commercial
	PGE210135	Water Infrastructure and System Efficiency	\$ 542,679	\$ -	\$ -	\$ -	Third/Local Party	Industrial
	PGE21015	Commercial HVAC	\$ 3,670,302	\$ -	\$ -	\$ -	IOU Core/Statewide	Commercial
	PGE21018	EnergySmart Grocer	\$ 2,098,867	\$ -	\$ -	\$ -	Third/Local Party	Commercial
	PGE21026	Energy Efficiency Services for Oil Production	\$ 308,425	\$ -	\$ -	\$ -	Third/Local Party	Industrial
	PGE210311	Process Wastewater Treatment EM Pgm for Ag Food Processing	\$ 33,998	\$ -	\$ -	\$ -	Third/Local Party	Agricultural
	PGE210312	Dairy and Winery Industry Efficiency Solutions	\$ 561,639	\$ -	\$ -	\$ -	Third/Local Party	Agricultural
	PGE21039	Comprehensive Food Process Audit & Resource Efficiency Pgm	\$ 287,687	\$ -	\$ -	\$ -	Third/Local Party	Agricultural
	PGE2110052	Strategic Energy Resources	\$ 3,677,383	\$ -	\$ -	\$ -	Local Government Partnership	Public
	PGE21061	Technology Development Support	\$ 56,813	\$ -	\$ -	\$ -	IOU Core/Statewide	Cross-Cutting
	PGE21076	Career and Workforce Readiness	\$ -	\$ -	\$ -	\$ -	IOU Core/Statewide	Cross-Cutting

Attachment 4, Table 4  
 PA Name: Pacific Gas and Electric Company  
 Budget Year: 2021

Table 4 – Budget, Spent, Unspent, Carryover Details [1]

New/Existing Program #	Discontinued Program #	Main Program Name / Sub-Program Name	2020 Budget Spent as of 07/31/2020 [2]	2021 Proposed Budget	2021 Budget Offset (Expected 2020 Unspent/ Uncommitted and Any Remaining Pre-2020 Unspent/ Uncommitted Funding)	2021 Funds Requested	Program Type	New Business Sector
	PGE21041	Primary Lighting	\$ 136,275	\$ -	\$ -	\$ -	IOU Core/Statewide	Residential
	PGE21042	Lighting Innovation	\$ 3,857	\$ -	\$ -	\$ -	IOU Core/Statewide	Cross-Cutting
	PGE21051	Building Codes Advocacy [7]	\$ (503,023)	\$ -	\$ -	\$ -	IOU Core/Statewide	Cross-Cutting
	PGE21052	Appliance Standards Advocacy [7]	\$ 68,175	\$ -	\$ -	\$ -	IOU Core/Statewide	Cross-Cutting
	PGE21057	National Codes & Standards Advocacy [7]	\$ 4,590	\$ -	\$ -	\$ -	IOU Core/Statewide	Cross-Cutting
	PGE21073	Strategic Planning [8]	\$ (4,034)	\$ -	\$ -	\$ -	IOU Core/Statewide	Cross-Cutting
<b>PA PROGRAM TOTAL</b>			<b>\$ 98,559,792</b>	<b>\$ 228,215,304</b>	<b>\$ -</b>	<b>\$ 228,215,304</b>		
<b>EM&amp;V (PA &amp; CPUC Portions) Total</b>								
EM&V CPUC		PG&E EM&V - CPUC	\$ 2,030,129	\$ 6,619,004	\$ -	\$ 6,619,004	IOU Core/Statewide	Cross-Cutting
EM&V PG&E		PG&E EM&V - PG&E	\$ 1,114,028	\$ 2,889,967	\$ -	\$ 2,889,967	IOU Core/Statewide	Cross-Cutting
<b>PA TOTAL with EM&amp;V</b>			<b>\$ 101,703,948</b>	<b>\$ 237,724,275</b>	<b>\$ -</b>	<b>\$ 237,724,275</b>		
<b>Estimated Funds to be Returned in 2021 Rates</b>					\$ 10,000,000	\$ (10,000,000)		
<b>TOTAL PA EE PORTFOLIO</b>			<b>\$ 101,703,948</b>	<b>\$ 237,724,275</b>	<b>\$ 10,000,000</b>	<b>\$ 227,724,275</b>		
<b>ME&amp;O &amp; ESA</b>								
PGE_SWMEO	PGE_SWMEO	Statewide Marketing, Education & Outreach (EE portion only) [9]	\$ 4,733,981	\$ 6,859,212			IOU Core/Statewide	Cross-Cutting
PGE_ESA	PGE_ESA	Energy Savings Assistance Program [10]	\$ 71,405,519	\$ 123,400,000			IOU Core/Statewide	Residential

[1] Details of PG&E's program changes for its 2021 portfolio can be found in Section III.G. of the advice letter.

[2] PG&E's 2020 EE budget was approved on December 24, 2019 in Advice Letter 4136-G/5627-E and supplement.

[3] The Program IDs for Residential Energy Advisor (PGE21001), Pay for Performance Pilot (PGE210010), and Industrial Strategic Energy Management (PGE21030) are being discontinued in CEDARS in 2021, however program activities from these two programs will continue in 2021 under multiple new Program IDs. Program activities from Residential Energy Advisor (PGE21001) will continue under PGE\_Res\_002a, PGE\_Res\_002b, and PGE\_Res\_002c. Program activities from the Pay for Performance Pilot (PGE210010) will continue under PGE\_Res\_001a, PGE\_Res\_001b, PGE\_Res\_001c, and PGE\_Res\_001d. Program activities from Industrial Strategic Energy Management (PGE21030) will continue under PGE\_Ind\_001a and

[4] The Program IDs for Energy Upgrade California Program (PGE21004) and the Residential HVAC Program (PGE21006) are being discontinued in CEDARS in 2021, however program activities from these two programs will continue in 2021 under

[5] Third-party financing will be closed upon completion of commitments in 2021 or 2022. This program is forecasted with \$0 budget because no 2021 spend is expected, however a contract is still in place for management of the remaining third-party

[6] New Finance Offerings program is excluded from the EE ABAL budget as funding for this program was approved via D.13-09-044. See advice letter p.5.

[7] Minimal expenditures are reported for Q1 2020 for these programs as a result of the transition to new statewide Codes and Standards Advocacy programs. See Section III.G. of the advice letter for more details.

[8] Strategic planning was sunset in PG&E's 2019 ABAL (Advice 4011-G/5376-E). Residual portfolio overhead payments are shown in Q1 2020 expenditures.

[9] Statewide ME&O budgets for 2017 through September 2019 were approved in Advice Letter 3783-G/4963-E on January 23, 2017, effective November 28, 2016. Budgets for October 2019 through 2021 were approved in Advice Letter 4098-G/5544-

[10] ESA budget reflects the authorized funding per year in D.16-11-022 and approved midcycle request as per approval from AL 3990-G/5329-E and supplements, on January 4, 2019

Attachment 4, Table 5

PA Name: Pacific Gas and Electric Company

Budget Year: 2021

**Table 5 - Total 2021 Requested and 2017-2020 Revenue Collected (\$000)**

Category (2017-20 Authorized <sup>[1]</sup> and 2021 Request)	Electric Demand Response Funds	Electric Energy Efficiency Funds	Natural Gas Public Purpose Funds	Total Energy Efficiency Funds
2017 Program Funds - Utility	\$ 3,264	\$ 327,271	\$ 62,337	\$ 389,609
2017 Program Funds - REN		\$ 13,891	\$ 2,646	\$ 16,537
2017 Program Funds - CCA		\$ 1,333	\$ 254	\$ 1,586
2017 EM&V		\$ 14,271	\$ 2,718	\$ 16,989
<b>2017 Annualized Total</b>	<b>\$ 3,264</b>	<b>\$ 356,766</b>	<b>\$ 67,955</b>	<b>\$ 424,721</b>
2018 Program Funds - Utility	\$ 3,264	\$ 307,407	\$ 58,554	\$ 365,961
2018 Program Funds - BayREN		\$ 18,787	\$ 3,578	\$ 22,365
2018 Program Funds - MCE		\$ 6,891	\$ 1,313	\$ 8,204
2018 EM&V		\$ 13,879	\$ 2,644	\$ 16,522
<b>2018 Annualized Total</b>	<b>\$ 3,264</b>	<b>\$ 346,964</b>	<b>\$ 66,088</b>	<b>\$ 413,052</b>
2019 Program Funds - Utility	\$ 7,771	\$ 233,116	\$ 73,615	\$ 306,731
2019 Program Funds - BayREN (including EM&V)		\$ 18,266	\$ 5,768	\$ 24,034
2019 Program Funds - MCE (including EM&V)		\$ 5,279	\$ 1,667	\$ 6,946
2019 Program Funds - 3C-REN (including EM&V)		\$ 2,153	\$ 680	\$ 2,833
2019 EM&V (IOU only)		\$ 9,713	\$ 3,067	\$ 12,780
<b>2019 Annualized Total</b>	<b>\$ 7,771</b>	<b>\$ 268,527</b>	<b>\$ 84,798</b>	<b>\$ 353,325</b>
2020 Program Funds - Utility	\$ 7,771	\$ 159,760	\$ 68,469	\$ 228,229
2020 Program Funds - BayREN (including EM&V)		\$ 16,612	\$ 7,119	\$ 23,731
2020 Program Funds - MCE (including EM&V)		\$ 4,958	\$ 2,125	\$ 7,083
2020 Program Funds - 3C-REN (including EM&V)		\$ 2,082	\$ 892	\$ 2,975
2020 EM&V (IOU only)		\$ 6,657	\$ 2,853	\$ 9,510
<b>2020 Annualized Total</b>	<b>\$ 7,771</b>	<b>\$ 190,069</b>	<b>\$ 81,458</b>	<b>\$ 271,527</b>
2021 Requested Program Funds - Utility <sup>[2]</sup>	\$ 8,000	\$ 189,568	\$ 38,647	\$ 228,215
2021 Requested Program Funds - BayREN (incl. EM&V)		\$ 20,674	\$ 4,234	\$ 24,908
2021 Requested Program Funds - MCE (incl. EM&V)		\$ 6,508	\$ 1,333	\$ 7,841
2021 Requested Program Funds - 3C-REN (incl. EM&V)		\$ 3,390	\$ 694	\$ 4,084
2021 Requested EM&V (IOU only) <sup>[2]</sup>		\$ 7,892	\$ 1,617	\$ 9,509
<b>2021 Total Portfolio Request</b>	<b>\$ 8,000</b>	<b>\$ 228,032</b>	<b>\$ 46,526</b>	<b>\$ 274,557</b>

[1] The authorized budget excludes reductions from past unspent funds and carryover and is consistent with funding approved in D. 09-09-047, D. 12-11-015, D.14-10-046 and D.15-10-028.

[2] The electric and gas split for program year 2021 is forecasted to be 83%/17%, applicable to the portion of PG&E's EE portfolio budget that will not be supporting fuel substitution program activities (including EM&V). The portfolio budget that is forecasted to support fuel-substitution activities will be recovered 100% through electric rates only. See advice letter Section III.J.1., Table 15 for more details on the fuel-substitution budget.

Attachment 4, Table 6

PA Name: Pacific Gas and Electric Company

Budget Year: 2021

Table 6 - Committed Energy Efficiency Program Funding - Funds Not Yet Spent as of 7/31/2020

Accrued funds not yet spent (\$000).	Electric Procurement Funds	Natural Gas Public Purpose Funds	Total
Category			
2013-2015 to date EM&V Funds	\$2,598	\$570	\$3,169
2013-2015 to date Program Funds - Utility [1]	(\$189)	(\$42)	(\$231)
2013-2015 to date Program Funds - BayREN	\$3,084	\$677	\$3,761
2013-2015 to date Program Funds - MCE	\$30	\$7	\$36
2016 to date EM&V Funds	\$12,852	\$2,821	\$15,673
2016 to date Program Funds - Utility [1]	\$0	\$0	\$0
2016 to date Program Funds - BayREN	\$0	\$0	\$0
2016 to date Program Funds - MCE	\$86	\$19	\$105
2017 to date EM&V Funds	\$12,162	\$2,317	\$14,479
2017 to date Program Funds - Utility [1]	\$139	\$26	\$165
2017 to date Program Funds - BayREN	\$36	\$7	\$43
2017 to date Program Funds - MCE	\$0	\$0	\$0
2018 to date EM&V Funds	\$9,661	\$1,840	\$11,501
2018 to date Program Funds - Utility [1]	\$185	\$35	\$221
2018 to date Program Funds - BayREN	\$4,384	\$835	\$5,219
2018 to date Program Funds - MCE	\$188	\$36	\$224
2019 to date EM&V Funds	\$0	\$0	\$0
2019 to date Program Funds - Utility [1]	\$380	\$120	\$500
2019 to date Program Funds - BayREN	\$2,272	\$718	\$2,990
2019 to date Program Funds - MCE	(\$43)	(\$14)	(\$57)
2019 to date Program Funds - 3C REN	\$1,840	\$581	\$2,420
2020 to date EM&V Funds	\$4,456	\$1,910	\$6,365
2020 to date Program Funds - Utility [1]	\$350	\$150	\$500
2020 to date Program Funds - REN	\$4,387	\$1,880	\$6,267
2020 to date Program Funds - CCA	\$3,759	\$1,611	\$5,371
2020 to date Program Funds - 3C REN	\$1,445	\$619	\$2,064

[1] Utility Funds represent New Financing Pilots funding initially authorized in the 2013-2015 cycle. Additional funding for this program was authorized in AL 3904-G/5175-E, approved effective December 3, 2017. \$500,000 per year for 2017 through 2020 were committed to continuously fund this program.

**Attachment 4, Table 7**

**PA Name: Pacific Gas and Electric Company**

**Budget Year: 2021**

**Table 7 - 2020 Authorized and Spent/Unspent Detail (Spend as of July 31, 2020)**

<b>Authorized, spent and unspent program funds (Excludes IOU EM&amp;V and OBF Loans) (\$000)</b>	<b>Electric Procurement Funds</b>	<b>Natural Gas Public Purpose Funds</b>	<b>Total</b>
<b>Category</b>			
2020 Annualized Authorized Program Budget	\$ 174,667	\$ 73,851	\$ 248,518
2020 Actual Spent [1]	\$ 75,052	\$ 30,843	\$ 105,895
2020 Unspent before deducting committed funds	\$ 99,615	\$ 43,008	\$ 142,623
2020 Committed funds [2]	\$ 9,941	\$ 4,261	\$ 14,202
2020 Unspent as of July 31, 2020 [3]	\$ 89,674	\$ 38,747	\$ 128,421
2020 Unspent/uncommitted - estimated available for 2021 [4]	\$ 16,852	\$ 7,222	\$ 24,075

[1] Actual spent means funds expensed, including accruals and payments made on previous year commitments as of July 31, 2020.

[2] 2020 Committed funds as of July 31, 2020. Represents unspent and committed Financing Pilots, BayREN, MCE, and 3C REN funds.

[3] Excludes \$533,000 of interest accrued in the balancing account through July 31, 2020 (\$423,000 electric; \$110,000 gas).

[4] Funds to be amortized in 2021 rates. Includes estimated unspent & uncommitted from PG&E of \$10,000,000 and carryover funds from Non-IOU entities of \$14,075,000. Carryover for BayREN, 3C-REN, and MCE were taken from their respective 2021 ABAL presentations to CAEECC on August 5, 2020. Carryover from these presentations is assumed to include carryover from both 2019 and 2020, but the carryover estimates were not broken out by year. PG&E assumed the 2020 electric/gas split of 70%/30% for all carryover in the absence of more precise information. Final 2021 cost recovery amounts, including carryover broken out by program year and corresponding electric/gas split, will be filed by PG&E in a Tier 1 advice letter following the issuance of 2021 ABAL dispositions for PG&E, BayREN, 3C-REN, and MCE.

Attachment 4, Table 8  
Statewide Program Budgets Table

(Col E)\*(IOU 'Electric Proportional Share' from INPUT TABLE) +  
[(1-Col E)\*(IOU 'Gas Proportional Share' from INPUT TABLE)]

Statewide Program*	Lead IOU	Col A	Col B	Col C	Col D	Col E	Combined (Electric & Gas) Proportional Contribution per Load-Share (Target share. Actual funding may be within +/-20%)				2021 Program Forecast by IOU**				2022 Program Budget by IOU**				Maximum Annual Budget After Launch			
		2021 Program Budget (Total for all contributing IOUs)**	2022 Program Budget (Total for all contributing IOUs)**	Maximum Annual Program Budget (Total for all contributing IOUs)****	Expected or Actual Launch Date (MM/YYYY)***	Percent Electric	PG&E	SDG&E	SCE	SCG	PG&E	SDG&E	SCE	SCG	PG&E	SDG&E	SCE	SCG	PG&E	SDG&E	SCE	SCG
Workforce education, and training: Career and workforce readiness	PG&E	\$ 1,232,332	\$2,112,569	\$ 2,112,569	Jul-2021	80%	45.60%	13.96%	32.08%	8.36%	\$ 561,943	\$ 172,034	\$ 395,332	\$ 103,023	\$ 963,331	\$ 294,915	\$ 677,712	\$ 176,611	\$ 963,331	\$ 294,915	\$ 677,712	\$ 176,611
Res New Construction		\$ 5,292,000	\$8,862,000	\$ 12,000,000	Jun-2021	80%	45.60%	13.96%	32.08%	8.36%	\$ 2,413,152	\$ 738,763	\$ 1,697,674	\$ 442,411	\$ 4,041,072	\$ 1,237,135	\$ 2,842,930	\$ 740,863	\$ 5,472,000	\$ 1,675,200	\$ 3,849,600	\$ 1,003,200
NonRes New Construction		\$ 2,000,000	\$14,000,000	\$ 20,000,000	Jun-2021	80%	45.60%	13.96%	32.08%	8.36%	\$ 912,000	\$ 279,200	\$ 641,600	\$ 167,200	\$ 6,384,000	\$ 1,954,400	\$ 4,491,200	\$ 1,170,400	\$ 9,120,000	\$ 2,792,000	\$ 6,416,000	\$ 1,672,000
Codes and Standards Advocacy		\$ 13,155,000	\$13,155,000	\$ 13,155,000	Feb-2020	80%	45.60%	13.96%	32.08%	8.36%	\$ 5,998,680	\$ 1,836,438	\$ 4,220,124	\$ 1,099,758	\$ 5,998,680	\$ 1,836,438	\$ 4,220,124	\$ 1,099,758	\$ 5,998,680	\$ 1,836,438	\$ 4,220,124	\$ 1,099,758
Institutional Partnerships, DGS & Dept of Corrections	SCE	\$ 416,667	\$2,500,000	\$ 5,000,000	Aug-2021	80%	45.60%	13.96%	32.08%	8.36%	\$ 190,000	\$ 58,167	\$ 133,667	\$ 34,833	\$ 1,140,000	\$ 349,000	\$ 802,000	\$ 209,000	\$ 2,280,000	\$ 698,000	\$ 1,604,000	\$ 418,000
WER&T Career Connections		\$ 583,333	\$1,000,000	\$ 1,000,000	Jul-2021	80%	45.60%	13.96%	32.08%	8.36%	\$ 266,000	\$ 81,433	\$ 187,133	\$ 48,767	\$ 456,000	\$ 139,600	\$ 320,800	\$ 83,600	\$ 456,000	\$ 139,600	\$ 320,800	\$ 83,600
Water/wastewater pumping	SCG	\$ -	\$1,846,970	\$ 5,300,000	Sep-2022	80%	45.60%	13.96%	32.08%	8.36%	\$ -	\$ -	\$ -	\$ -	\$ 842,218	\$ 257,837	\$ 592,508	\$ 154,407	\$ 2,416,800	\$ 739,880	\$ 1,700,240	\$ 443,080
Lighting (Upstream)		\$ 8,000,000	\$12,000,000	\$ 12,000,000	May-2021	100%	44.40%	15.50%	40.10%	0.00%	\$ 3,552,000	\$ 1,240,000	\$ 3,208,000	\$ -	\$ 5,328,000	\$ 1,860,000	\$ 4,812,000	\$ -	\$ 5,328,000	\$ 1,860,000	\$ 4,812,000	\$ -
ETP, electric		\$ -	\$14,032,875	\$ 17,897,000	Apr-2022	100%	44.40%	15.50%	40.10%	0.00%	\$ -	\$ -	\$ -	\$ -	\$ 6,230,597	\$ 2,175,096	\$ 5,627,183	\$ -	\$ 7,946,268	\$ 2,774,035	\$ 7,176,697	\$ -
Institutional Partnerships, UC/CSU/CCC	SDG&E	\$ -	\$1,393,939	\$ 4,000,000	Sep-2022	80%	45.60%	13.96%	32.08%	8.36%	\$ -	\$ -	\$ -	\$ -	\$ 635,636	\$ 194,594	\$ 447,176	\$ 116,533	\$ 1,824,000	\$ 558,400	\$ 1,283,200	\$ 334,400
ETP, gas *****		\$3,000,000	\$3,000,000	\$ 3,000,000	Jul-2021	0%	50.40%	7.80%	0.00%	41.80%	\$ 1,512,000	\$ 234,000	\$ -	\$ 1,254,000	\$ 1,512,000	\$ 234,000	\$ -	\$ 1,254,000	\$ 1,512,000	\$ 234,000	\$ -	\$ 1,254,000
Food Service POS		\$8,836,824	\$10,877,696	\$ 12,227,068	Apr-2021	40%	48.00%	10.88%	16.04%	25.08%	\$ 4,241,676	\$ 961,446	\$ 1,417,427	\$ 2,216,275	\$ 5,221,294	\$ 1,183,493	\$ 1,744,782	\$ 2,728,126	\$ 5,868,993	\$ 1,330,305	\$ 1,961,222	\$ 3,066,549
Midstream Comm Water Heating		\$8,087,900	\$9,640,241	\$ 11,192,583	Apr-2021	40%	48.00%	10.88%	16.04%	25.08%	\$ 3,882,192	\$ 879,964	\$ 1,297,299	\$ 2,028,445	\$ 4,627,316	\$ 1,048,858	\$ 1,546,295	\$ 2,417,772	\$ 5,372,440	\$ 1,217,753	\$ 1,795,290	\$ 2,807,100
Res HVAC QI/QM	SDG&E	\$ -	\$ 6,900,000	\$ 6,900,000	Apr-2023	80%	45.60%	13.96%	32.08%	8.36%	\$ -	\$ -	\$ -	\$ -	\$ -	\$ -	\$ -	\$ -	\$ 3,146,400	\$ 963,240	\$ 2,213,520	\$ 576,840
Plug Load and Appliance		\$ 7,250,000	\$29,356,559	\$29,356,559	Sep-2021	80%	45.60%	13.96%	32.08%	8.36%	\$ 3,306,000	\$ 1,012,100	\$ 2,325,800	\$ 606,100	\$ 13,386,591	\$ 4,098,176	\$ 9,417,584	\$ 2,454,208	\$ 13,386,591	\$ 4,098,176	\$ 9,417,584	\$ 2,454,208
Upstream HVAC (Comm + Res)		\$ 10,341,930	\$12,652,339	\$ 12,652,339	Jan-2021	80%	45.60%	13.96%	32.08%	8.36%	\$ 4,715,920	\$ 1,443,733	\$ 3,317,691	\$ 864,585	\$ 5,769,467	\$ 1,766,267	\$ 4,058,870	\$ 1,057,736	\$ 5,769,467	\$ 1,766,267	\$ 4,058,870	\$ 1,057,736
<b>Total</b>		<b>\$ 68,195,986</b>	<b>\$ 136,430,188</b>	<b>\$ 167,793,118</b>							<b>\$ 31,551,563</b>	<b>\$ 8,937,278</b>	<b>\$ 18,841,747</b>	<b>\$ 8,865,398</b>	<b>\$ 62,536,202</b>	<b>\$ 18,629,808</b>	<b>\$ 41,601,164</b>	<b>\$ 13,663,014</b>	<b>\$ 76,860,970</b>	<b>\$ 22,978,208</b>	<b>\$ 51,506,860</b>	<b>\$ 16,447,081</b>

\*The numbers in this table are accurate as of August 14, 2020, and are reflected in all of PG&E's 2021 ABAL materials, including its advice letter and CEDARS filing submission. Any changes made by a SW lead after August 14, 2020 are not reflected in this table.

\*\*The budget is proportional to the anticipated launch date of the program.

\*\*\*Launch date assumes that the signed contracts filed via AL are approved by ED in 90-days, where applicable.

\*\*\*\*Maximum annual program budget subject to change with consensus across IOUs

BP Decision (D.18-05-041): OP 23. The 25 percent requirement for statewide funding articulated in D.16-08-019 shall be calculated as a proportion of the utility program administrator's total portfolio budget, including evaluation, measurement, and verification funding, but excluding funding allocated to other program administrators for other (non-statewide) programs. The percentage requirement for statewide program funding for the Southern California Gas Company shall be reduced to 15 percent, but remain 25 percent for the other utility program administrators consistent with D.16-08-019.

IOU	Percent PPP Electric	Percent PPP Gas	Electric Proportional Share	Gas Proportional Share
PG&E	80%	20%	44.4%	50.4%
SDG&E	90%	10%	15.5%	7.8%
SCE	100%	0%	40.1%	0.0%
SoCalGas	0%	100%	0.0%	41.8%

Table 10: Caps and Targets

2021 Energy Efficiency Caps And Target Expenditure Projections							
		Expenditures			Cap & Target Performance		
Line	Budget Category	Non-Third- Party Qualifying Costs (including PA costs and old-definition 3P/GP contracts that don't meet the new definition)	Third Party Qualifying Costs <sup>2</sup> (including SW)	Total Portfolio	Percent of Budget	Cap %	Target %
1	<b>Administrative Costs</b>	<b>\$19,147,169</b>	<b>\$6,352,591</b>	<b>\$25,499,760</b>			
2	IOU <sup>1</sup>	\$14,284,835	\$0	\$14,284,835	<b>5.8%</b>	<b>10.0%</b>	
3	Third Party & Partnership <sup>2</sup>	\$1,469,291	\$5,958,779	\$7,428,070			<b>10.0%</b>
4	Target Exempt Programs <sup>3</sup>	\$3,393,043	\$393,812	\$3,786,855			
5	<b>Marketing and Outreach Costs <sup>4</sup></b>	<b>\$13,906,135</b>	<b>\$3,901,936</b>	<b>\$17,808,071</b>			
6	Marketing & Outreach	\$7,046,923	\$3,901,936	\$10,948,859	<b>4.5%</b>		<b>6.0%</b>
7	Statewide Marketing & Outreach <sup>5</sup>	\$6,859,212	\$0	\$6,859,212			
8	<b>Direct Implementation Costs</b>	<b>\$105,528,691</b>	<b>\$86,237,995</b>	<b>\$191,766,686</b>			
9	Direct Implementation (Incentives and Rebates)	\$42,370,572	\$29,057,177	\$71,427,749			
10	Direct Implementation (Non-Incentives and Non-Rebates)	\$36,855,064	\$52,079,626	\$88,934,690	<b>36.4%</b>		<b>20.0%</b>
11	Direct Implementation Target Exempt Programs <sup>3</sup>	\$26,303,055	\$5,101,192	\$31,404,247			
12	<b>EM&amp;V Costs (Investor Owned Utilities &amp; Energy Division) <sup>6,7</sup></b>	<b>\$9,508,971</b>	<b>\$0</b>	<b>\$9,508,971</b>	<b>4.0%</b>	<b>4.0%</b>	
13	<b>Total <sup>8</sup></b>	<b>\$148,090,966</b>	<b>\$96,492,522</b>	<b>\$244,583,487</b>			
14	<b>2021 Proposed Budget <sup>9</sup></b>	<b>\$141,231,754</b>	<b>\$96,492,522</b>	<b>\$237,724,275</b>			
15	<b>Third-Party Implementer Contracts (as defined per D.16-08-019, OP 10) <sup>10</sup></b>	<b>\$0</b>	<b>\$96,492,522</b>	<b>\$96,492,522</b>			

## PG&E 2021 EE ABAL Attachment 4

### Table 10: Caps and Targets

#### Table Notes:

1. 10% cap requirement based on D. 09-09-047 is set for IOU only.
2. New third-party program definition per D.16-08-019, OP 10. For Row 3 of this table, the "Third Party & Partnership" administrative costs under the "Non-Third Party Qualifying Costs" column are costs for programs that met the old Third-Party definition prior to the transition to the new third party definition.
3. Target Exempt Programs are Non-Resource Programs which include: Emerging Technologies, Workforce Education & Training, Strategic Energy Resources (SER) program, Third-Party Public LGPs, and Codes & Standards programs (excluding Building Codes Advocacy, Appliance Standards Advocacy and National Standards Advocacy).
4. Statewide Marketing & Outreach (SW ME&O) is excluded from the Marketing and Outreach cost target calculation per D.13-12-038, at p. 82.
5. The 2019-2021 Statewide ME&O budget is authorized in D.19-01-005. The amount in Line 7 represents the portion allocated to EE.
6. EM&V costs include only PG&E's IOU EM&V budget.
7. The EM&V percentage is based on PG&E's total programs budget of \$237,724,275, which excludes SWME&O, BayREN, MCE and 3C-REN. This is the Total in line 13, minus SWME&O in line 7.
8. As directed in the Energy Efficiency Policy Manual Version 6 April 2020, Appendix C, this total includes SW ME&O and excludes BayREN, MCE, and 3C-REN budgets and is the denominator used to calculate the Admin, Marketing, and Direct Implementation Non-Incentives percentages.
9. PG&E's 2021 Proposed Budget of \$237,724,275 excludes SWME&O budget of \$6,859,212 and excludes BayREN, MCE and 3C-REN budgets of \$24,907,863, \$7,840,956 and \$4,084,315 respectively.
10. PG&E's Third-Party Implementer Contracts (as defined per D.16-08-019, OP 10) includes third-party contract and incentive budgets and statewide qualifying contract and incentive budgets. This 2021 forecasted total is not used to calculate the third-party outsourcing compliance targets. Rather, outsourcing compliance targets are calculated using annualized total contract amounts for each qualifying third-party contract.































**PG&E Gas and Electric  
Advice Submittal List  
General Order 96-B, Section IV**

AT&T	Downey & Brand	Pioneer Community Energy
Albion Power Company	East Bay Community Energy	Redwood Coast Energy Authority
Alcantar & Kahl LLP	Ellison Schneider & Harris LLP	Regulatory & Cogeneration Service, Inc.
Alta Power Group, LLC	Energy Management Service	SCD Energy Solutions
Anderson & Poole	Engineers and Scientists of California	
Atlas ReFuel	GenOn Energy, Inc.	SCE
BART	Goodin, MacBride, Squeri, Schlotz & Ritchie	SDG&E and SoCalGas
Barkovich & Yap, Inc.	Green Power Institute	SPURR
California Cotton Ginners & Growers Assn	Hanna & Morton	San Francisco Water Power and Sewer
California Energy Commission	ICF	Seattle City Light
California Public Utilities Commission	IGS Energy	Sempra Utilities
California State Association of Counties	International Power Technology	Southern California Edison Company
Calpine	Intestate Gas Services, Inc.	Southern California Gas Company
Cameron-Daniel, P.C.	Kelly Group	Spark Energy
Casner, Steve	Ken Bohn Consulting	Sun Light & Power
Cenergy Power	Keyes & Fox LLP	Sunshine Design
Center for Biological Diversity	Leviton Manufacturing Co., Inc.	Tecogen, Inc.
Chevron Pipeline and Power	Los Angeles County Integrated	TerraVerde Renewable Partners
City of Palo Alto	Waste Management Task Force	Tiger Natural Gas, Inc.
City of San Jose	MRW & Associates	TransCanada
Clean Power Research	Manatt Phelps Phillips	Troutman Sanders LLP
Coast Economic Consulting	Marin Energy Authority	Utility Cost Management
Commercial Energy	McKenzie & Associates	Utility Power Solutions
Crossborder Energy	Modesto Irrigation District	Water and Energy Consulting Wellhead
Crown Road Energy, LLC	NLine Energy, Inc.	Electric Company
Davis Wright Tremaine LLP	NRG Solar	Western Manufactured Housing
Day Carter Murphy	Office of Ratepayer Advocates	Communities Association (WMA)
Dept of General Services	OnGrid Solar	Yep Energy
Don Pickett & Associates, Inc.	Pacific Gas and Electric Company	
Douglass & Liddell	Peninsula Clean Energy	