

AIRCRAFT MAINTENANCE MANUAL - PART I
SYSTEM DESCRIPTION SECTION

CHAPTER 09 – TOWING AND TAXIING

LIST OF EFFECTIVE PAGES

Ch-Se-Su	Effectivity	Page	Date	Ch-Se-Su	Effectivity	Page	Date
09 - Effective Pages							
ALL		1	Jan 15/2005				
09 - Contents	ALL	1	Jan 15/2005				
09-00-00	ALL	1	Jan 15/2005				
		2	Jan 15/2005				
		3	Jan 15/2005				
		4	Jan 15/2005				
		5	Jan 15/2005				
		6	Jan 15/2005				
		7	Jan 15/2005				
		8	Jan 15/2005				
		9	Jan 15/2005				
		10	Jan 15/2005				
		11	Jan 15/2005				

EFFECTIVITY: ALL

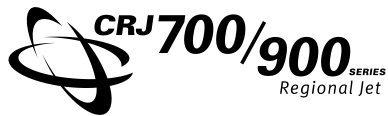

AIRCRAFT MAINTENANCE MANUAL - PART I
SYSTEM DESCRIPTION SECTION

CHAPTER 09 – TOWING AND TAXIING

TABLE OF CONTENTS

Subject	Ch-Se-Su	Effectivity	Page
TOWING AND TAXIING	09-00-00		
TOWING AND TAXING	A01	ALL	1
INTRODUCTION			
GENERAL DESCRIPTION			
TOWING (WITH A TOW BAR)			
TAXIING			4
TOWING AND TAXIING	AA1	ALL	6
INTRODUCTION			
GENERAL DESCRIPTION			
TOWING (WITH A TOW BAR)			
TAXIING			10

EFFECTIVITY: ALL

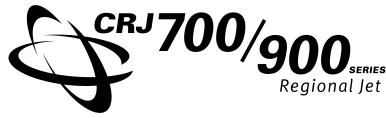

AIRCRAFT MAINTENANCE MANUAL - PART I
SYSTEM DESCRIPTION SECTION

On A/C 10001-10999

TASK 09-00-00-001-A01 TOWING AND TAXING

INTRODUCTION

This section contains data related to the procedures for towing and taxiing of the aircraft.

GENERAL DESCRIPTION

The aircraft can be towed or pushed with a towing tractor when it is not possible or practical to move the aircraft with its own power. A minimum of two persons is necessary to tow the aircraft. Five persons are required to tow the aircraft in restricted areas.

The pilot's seat is the only seat with the steering tiller and must be occupied for taxiing. The operator maneuvers the aircraft with the use of the engine power, differential braking and the nosewheel steering.

TOWING (WITH A TOW BAR)

Figures 09-00-00-000001
and 09-00-00-000002.

The aircraft can be pushed or towed with the tow bar connected to the axle of the nose landing gear and with the steering torque arms connected or disconnected. The nosewheel steering system must be selected to OFF before towing. The upper and lower torque links may be disconnected or connected with a steering angle limit of ± 70 degrees. The upper torque link is spring loaded against a stop to maintain its position clear of the nose wheels and aft door during towing. This will prevent the steering system and nose landing gear (NLG) from damage during towing. If NLG shock strut is not properly inflated there is a risk of interference between the tire and the disconnect upper torque link. Therefore, in this case towing must be done with the torque links connected and steering angle limit of ± 70

degrees. Towing is accomplished by connecting an approved tow bar to attachment fittings on the nose landing gear axle.

The equipment that is necessary to tow the aircraft is as follows :

- Tow tractor
- Main wheel chocks
- Tow bar
- Two headsets with extension cords
- Passenger door support cable

TRAINING INFORMATION POINTS

Before towing or taxiing, make sure that all three landing gear ground lockpins are installed.

If towing or taxiing is necessary with a flat tire(s), refer to the appropriate manual for the correct procedures or seek advise from the aircraft manufacturer.

During aircraft recovery missions, main gear towing of the aircraft forward or rearward with rope assemblies must be done as per the applicable manual or manufacturer's instructions. Obey all warnings and cautions to prevent damage to the landing gear, wire harness, and brake lines, etc.

A tow- barless towing tractor can also be used to tow the aircraft.

EFFECTIVITY: See first page of

TASK 09-00-00-001-A01

09-00-00

Page 1
Jan 15/2005

AIRCRAFT MAINTENANCE MANUAL - PART I
SYSTEM DESCRIPTION SECTION

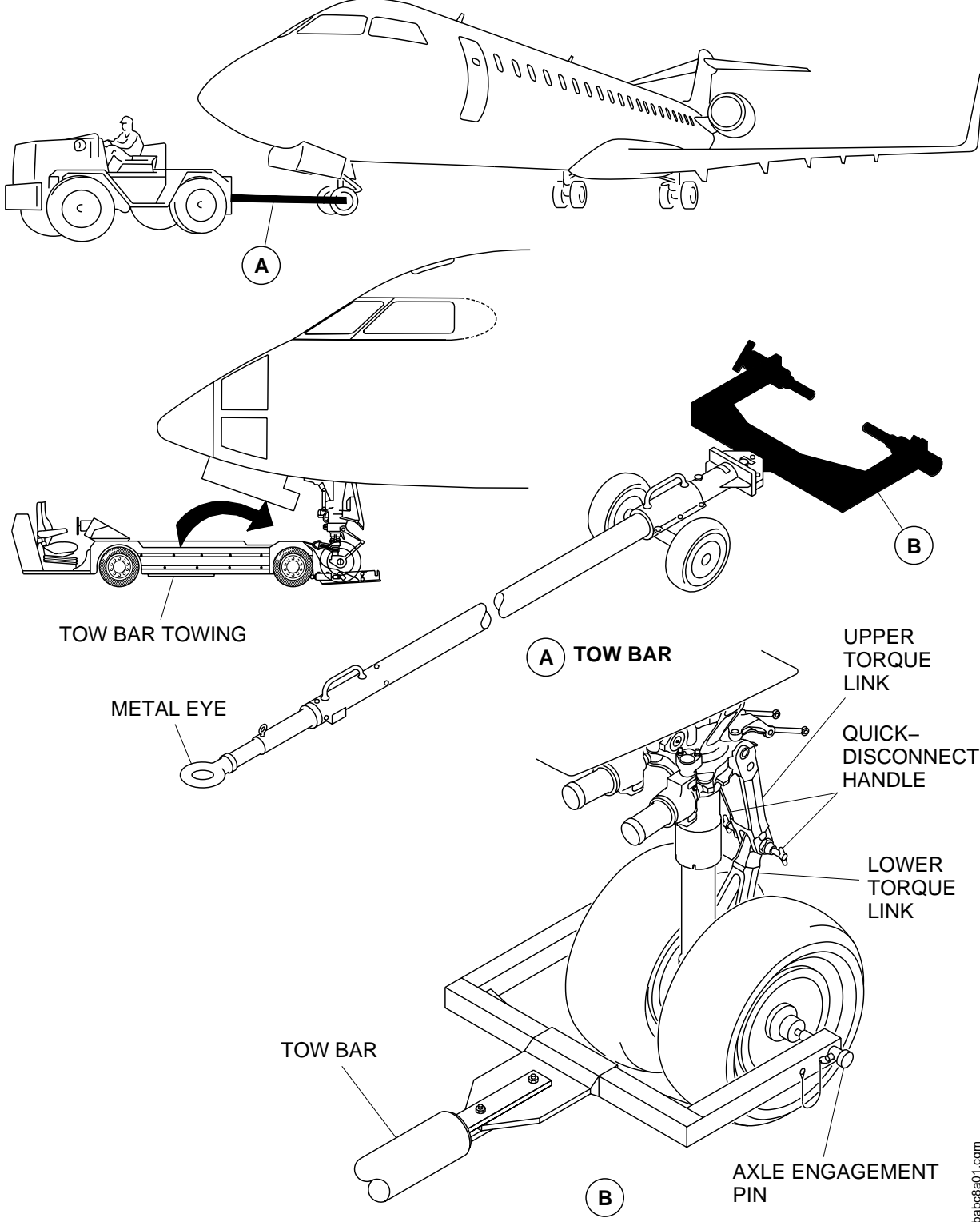

Tow Bar / Tow Barless Towing
Figure 09-00-00-000001

babc8a01.cgm

EFFECTIVITY: See first page of
 TASK 09-00-00-001-A01

AIRCRAFT MAINTENANCE MANUAL - PART I
SYSTEM DESCRIPTION SECTION

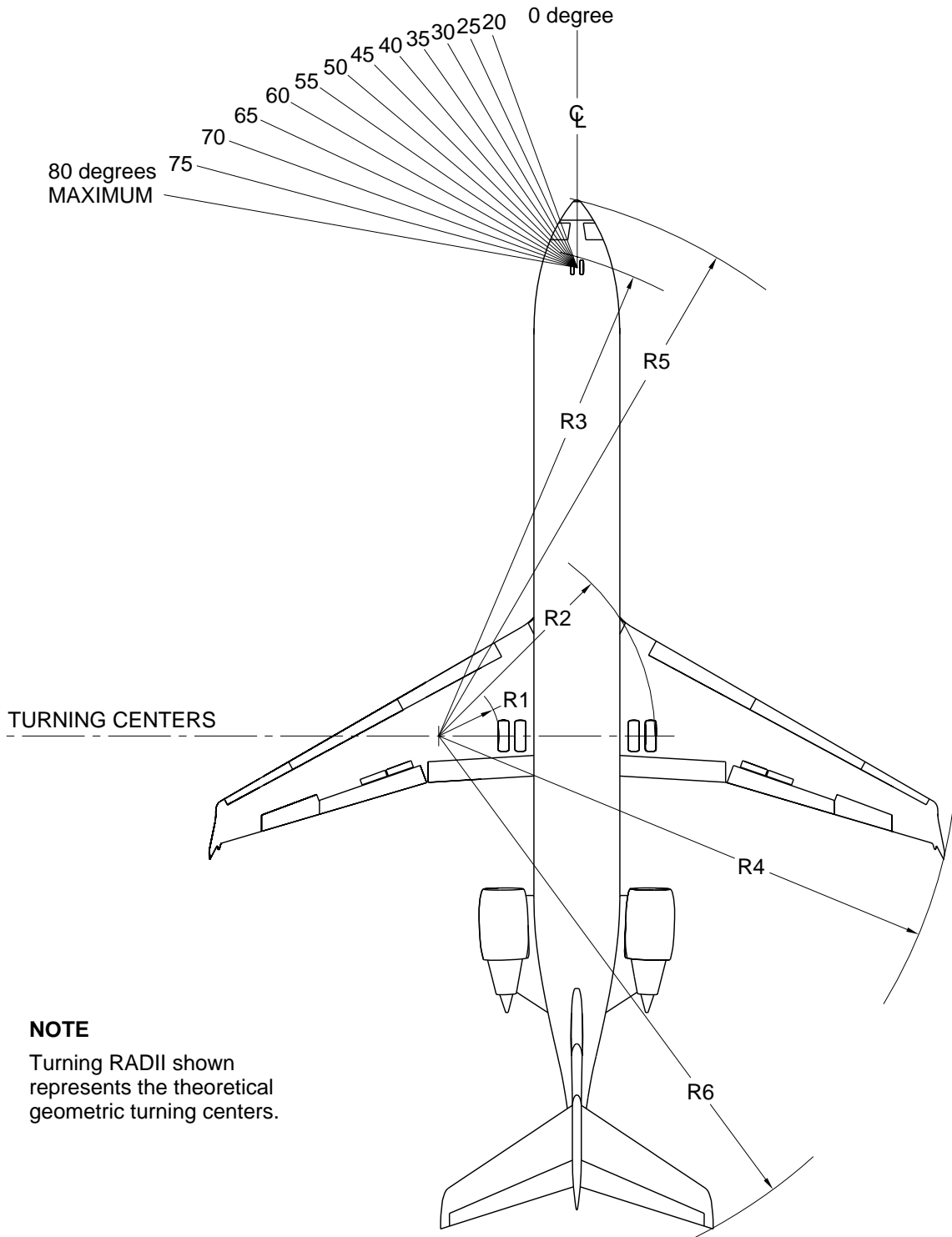

NOTE
 Turning RADII shown represents the theoretical geometric turning centers.

Towing - Turning Radius
 Figure 09-00-00-000002

EFFECTIVITY: See first page of
 TASK 09-00-00-001-A01

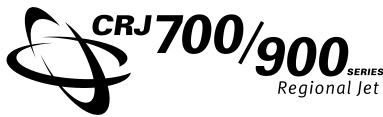

AIRCRAFT MAINTENANCE MANUAL - PART I
SYSTEM DESCRIPTION SECTION

TAXIING

Figure 09-00-00-000003.

When taxiing, the aircraft direction is normally controlled using the nosewheel steering system.

If the nosewheel steering system is not available, the aircraft direction can be controlled using differential thrust and braking. The maximum steering radius allowed is 80° left or right of center for either free-castering or central power steering.

TRAINING INFORMATION POINTS

The minimum towing crew consists of two qualified persons. One person operates the towing vehicle and the other person operates the aircraft brakes in the flight compartment. The aircraft brakes are used only in an emergency.

When the aircraft is towed in a confined space, in addition to the tow vehicle operator and the aircraft brake operator, one person must be at the end of each wing. That person must make sure sufficient distance is maintained to prevent contact with other objects or aircraft.

When the aircraft is pushed rearward, it is important to control and stop the movement of the aircraft using the towing vehicle. If the aircraft wheel brakes are used, it could lift the nose gear off ground.

Make sure that the nosewheel steering arming switch is OFF before the tow bar is connected to the aircraft.

Make sure there is sufficient weight on nosewheel before towing. This prevents the nose centering mechanism from coming into operation.

Obey the towing speed limits.

Make sure that the brake pressure is within limits before towing.

Towing the aircraft with one or both engines removed will affect the aircraft center-of-gravity. Ballast weight must be added before towing the aircraft.

Make sure that the tow bar is serviceable before connecting it to the nose gear axle.

EFFECTIVITY: See first page of

TASK 09-00-00-001-A01

09-00-00

Page 4
Jan 15/2005

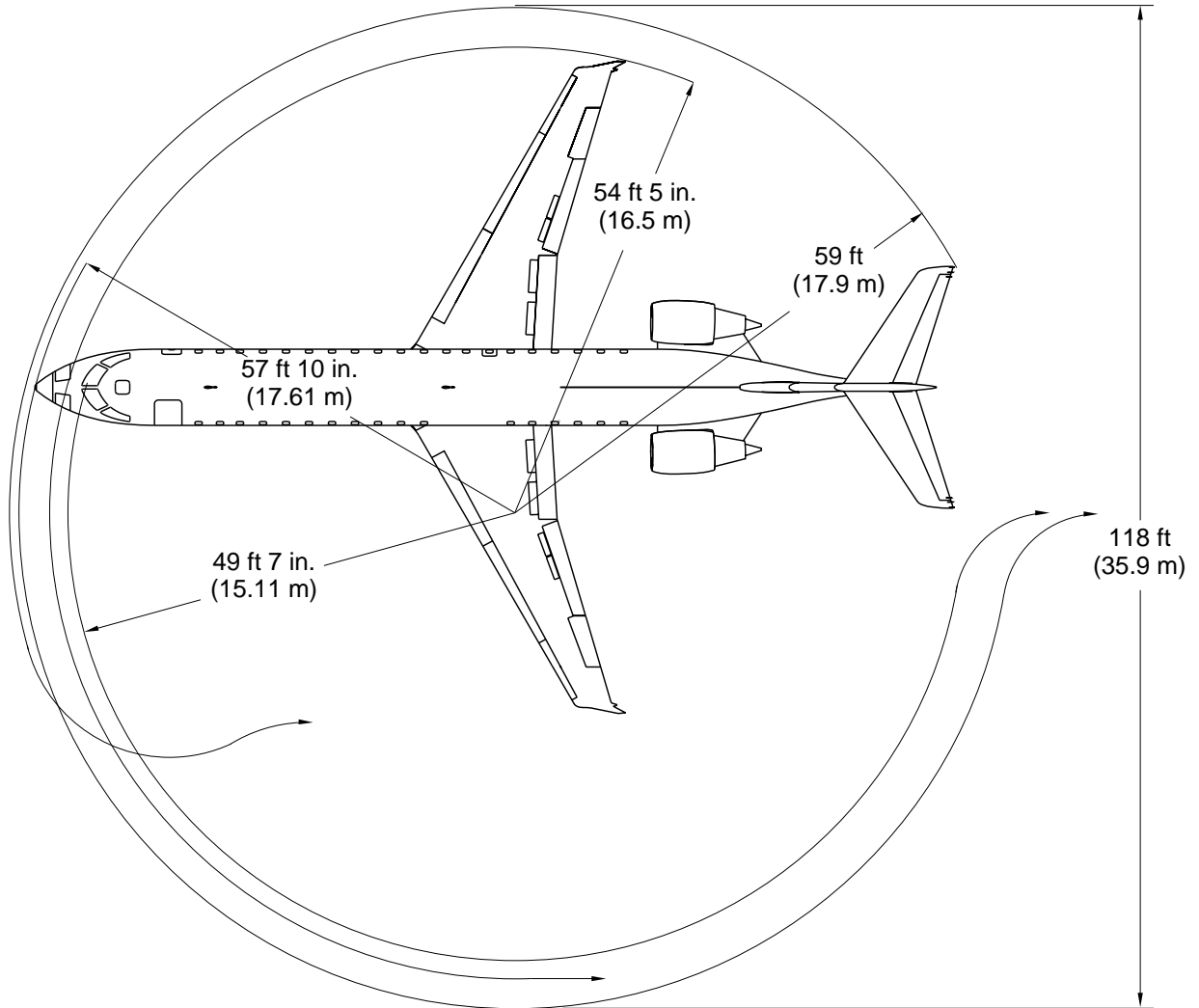

NOTE

MAXIMUM STEERING.
 Symmetrical and idle thrust.
 No differential braking.
 70 degrees steering angle.
 3 degrees slip.
 Dry runway.
 Slow continuous turn.
 Maximum A/C weight
 AFT CG.

Taxiing - Turning Radius
 Figure 09-00-00-000003

babc9a01.cgm

EFFECTIVITY: See first page of

TASK 09-00-00-001-A01

09-00-00

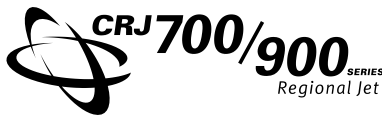

AIRCRAFT MAINTENANCE MANUAL - PART I
SYSTEM DESCRIPTION SECTION

On A/C 15001-15990

TASK 09-00-00-001-AA1 TOWING AND TAXIING

INTRODUCTION

This section contains data related to the procedures for towing and taxiing of the aircraft.

GENERAL DESCRIPTION

The aircraft can be towed or pushed with a towing tractor and a standard tow bar when it is not possible or practical to move the aircraft with its own power. A minimum of two persons is necessary to tow the aircraft. Five persons are required to tow the aircraft in restricted areas.

For taxiing, the pilot's seat is the only seat with the steering tiller, and must be occupied during taxiing. The operator maneuvers the aircraft with the use of the engine power, differential braking and the nosewheel steering.

TOWING (WITH A TOW BAR)

Figures 09-00-00-000007
and 09-00-00-000012.

The aircraft can be pushed or towed with the tow bar connected to the axle of the nose landing gear and with the steering torque links connected or disconnected. The nosewheel steering system must be selected to OFF before towing. With the torque links connected or disconnected, the turning angle limit of the nosewheel is 70° either side of center. The upper torque link is spring loaded against a stop to maintain its position clear of the nose wheels and aft door during towing. This will prevent the steering system and nose landing gear (NLG) from damage during towing.

If the NLG shock strut is not properly inflated there is a risk of interference between the tire and the disconnected upper torque link. Therefore, in this case towing must be done with the torque links connected. Towing is accomplished by connecting an approved tow

bar to attachment fittings on the nose landing gear axle

The equipment that is necessary to tow the aircraft is as follows:

- Tow tractor
- Main wheel chocks
- Tow bar
- Two headsets with extension cords
- Passenger door support cable

TRAINING INFORMATION POINTS

Before towing:

- Make sure that all three landing gear ground lockpins are installed
- Make sure that the brake pressure is within limits before towing.
- Make sure that the tow bar is serviceable before it is connected to the nose gear axle.
- Make sure there is sufficient weight on nosewheel before towing. This prevents the nose centering mechanism from coming into operation.
- Make sure that the nosewheel steering arming switch is OFF before connecting the tow bar to the aircraft.
- The minimum towing crew consists of two qualified persons. One person operates the towing vehicle and the other person operates the aircraft brakes in the flight compartment. The aircraft brakes are used only in an emergency.
- When the aircraft is towed in a confined space, in addition to the tow vehicle operator and the aircraft brake operator, one person must be at the end of each wing.
- Do not exceed the maximum towing speed of 3 MPH
- When the aircraft is pushed rearward, it is important to control and stop the movement of the aircraft using the towing vehicle. If the aircraft wheel brakes are used, it could lift the nose gear off ground and cause possible damage to the rear fuselage.

EFFECTIVITY: See first page of

TASK 09-00-00-001-AA1

09-00-00

Page 6
Jan 15/2005

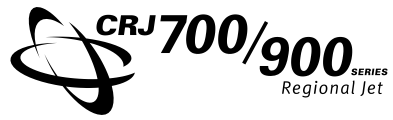

AIRCRAFT MAINTENANCE MANUAL - PART I
SYSTEM DESCRIPTION SECTION

- Towing the aircraft with one or both engines removed will affect the aircraft center-of-gravity. Ballast weight must be added before towing the aircraft.
- A tow-barless towing tractor can also be used to tow the aircraft.

EFFECTIVITY: See first page of

TASK 09-00-00-001-AA1

09-00-00

Page 7
Jan 15/2005

AIRCRAFT MAINTENANCE MANUAL - PART I
SYSTEM DESCRIPTION SECTION

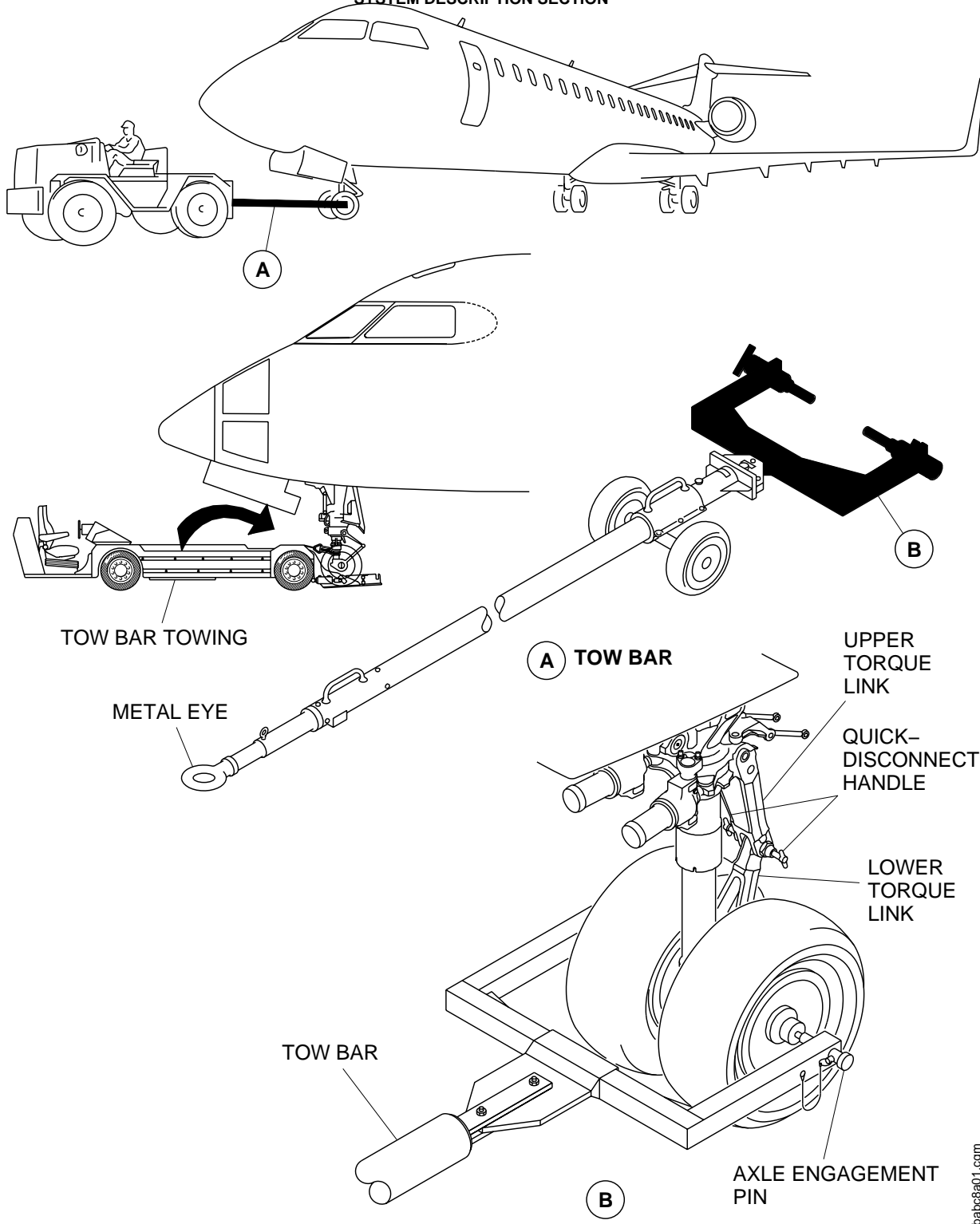

Tow Bar / Tow Barless Towing
Figure 09-00-00-000007

EFFECTIVITY: See first page of

TASK 09-00-00-001-AA1

AIRCRAFT MAINTENANCE MANUAL - PART I
SYSTEM DESCRIPTION SECTION

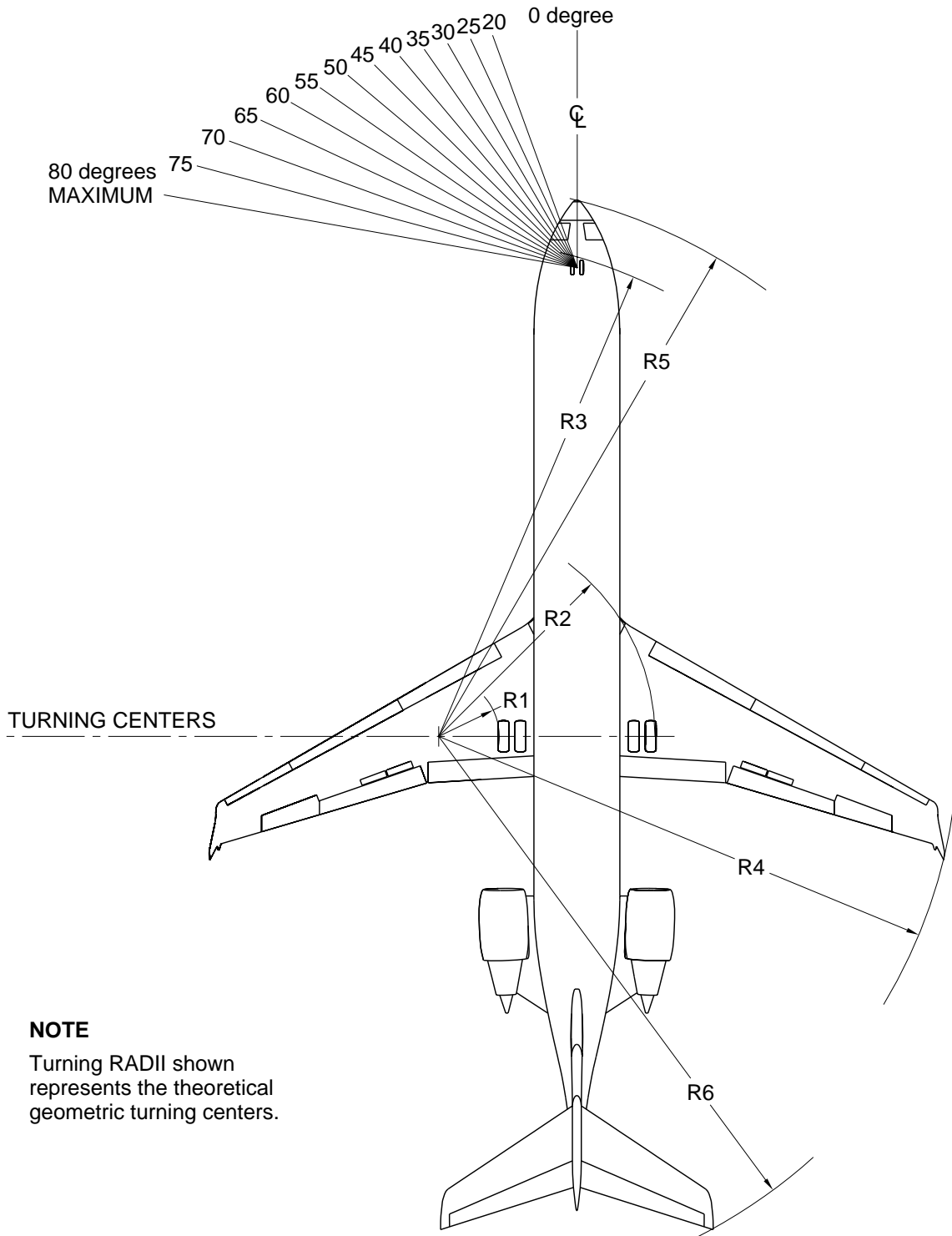

babj3a01.cgm

Towing - Turning Radius
 Figure 09-00-00-000012

EFFECTIVITY: See first page of
 TASK 09-00-00-001-AA1

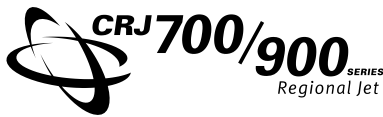

AIRCRAFT MAINTENANCE MANUAL - PART I
SYSTEM DESCRIPTION SECTION

TAXIING

Figure 09-00-00-000013.

When taxiing the aircraft, direction is usually controlled using the nosewheel steering system. If the nosewheel steering system is not available, the aircraft direction can be controlled using differential thrust and braking. The maximum steering radius allowed is $80\pm 2^\circ$ left or right of center for either free-castering or central power steering.

All personnel that taxi the aircraft must use an approved check list and follow all check list procedures.

TRAINING INFORMATION POINTS

In addition to the Training Information Points listed under aircraft towing, the conditions that follow must be met before taxiing the aircraft:

- Make sure the brake accumulators are precharged to 600 ± 50 psi.
- Make sure that the parking brake is ON
- Make sure hydraulic pumps No. 1, 2 and 3 are ON
- Make sure the brake pressure is 3000 ± 200 psi.
- Make sure that the Navigation lights are turned ON
- Make sure that the VHF radio(s) are set to the required ground frequency

NOTE

If there is a requirement to taxi the aircraft with a flat tire, refer to the Supplementary Procedures section of the Flight Crew Operating Manual

EFFECTIVITY: See first page of

TASK 09-00-00-001-AA1

09-00-00

Page 10
Jan 15/2005

AIRCRAFT MAINTENANCE MANUAL - PART I
SYSTEM DESCRIPTION SECTION

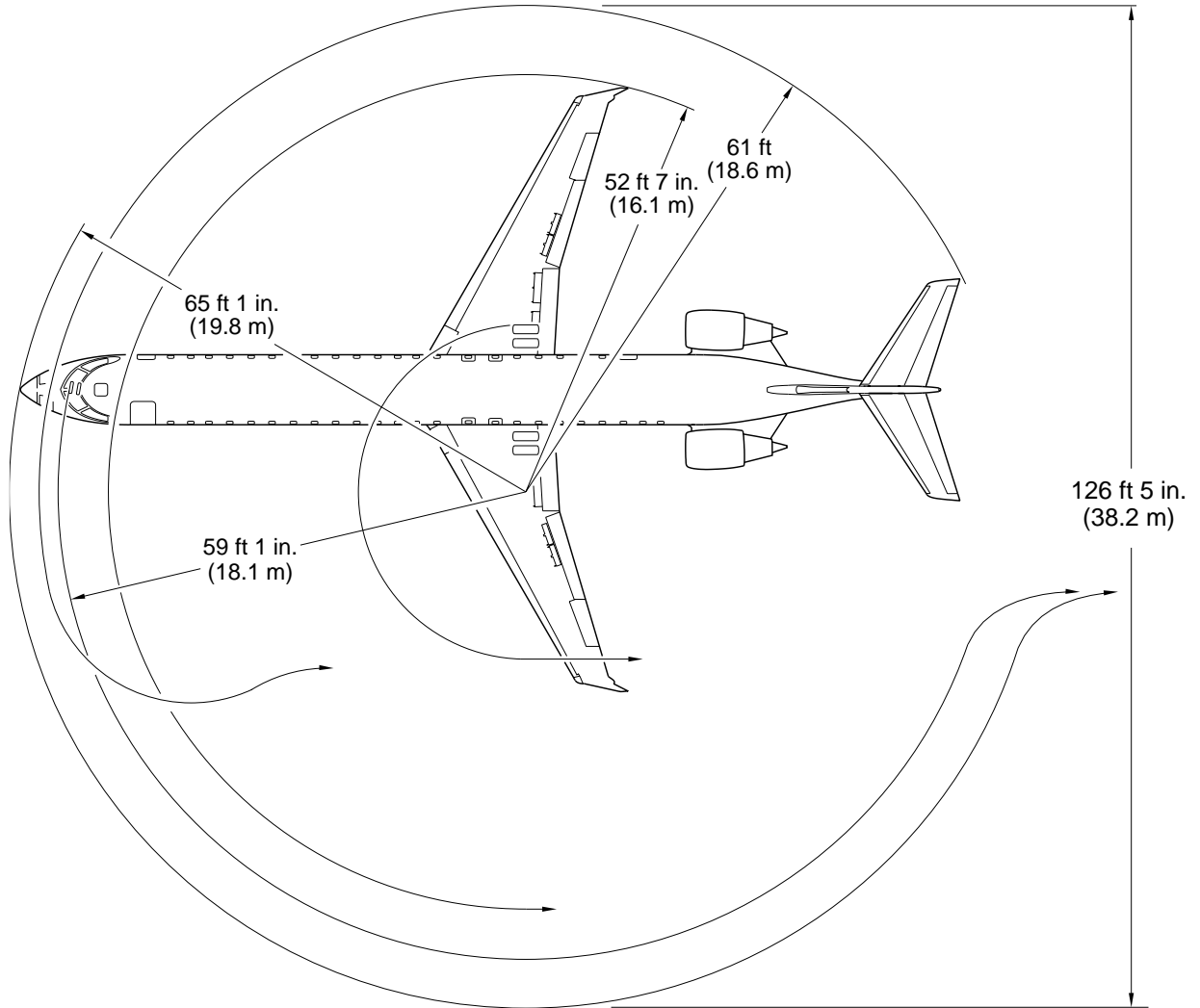

NOTE

MAXIMUM STEERING.
 Symmetrical and idle thrust.
 No differential braking.
 80 degrees steering angle.
 3 degrees slip.
 Dry runway.
 Slow continuous turn.
 Maximum A/C weight
 AFT CG.

baqqz01.cgm

Taxiing - Turning Radius
 Figure 09-00-00-000013

EFFECTIVITY: See first page of

TASK 09-00-00-001-AA1

09-00-00

