

## AVI 75 - INSTALLATION INSTRUCTIONS - VERTICAL

### General Notes:

Aire Technologies Series 75 Fire Dampers are approved for use in static systems with a fire rating of less than 3 hours and are to be installed vertically in accordance with the attitude label on the damper.

In testing Aire Technologies products, no caulking was used between the retaining angles and sleeve or between the retaining angles and partition. Application of such products in those areas shall only be done at the direction of the Authority Having Jurisdiction. The damper must be installed square. Twisting, racking, compressing, or stretching the damper into the opening is prohibited. Dust, dirt, paint, etcetera can inhibit the operation of the damper and can void the warranty. Special care must be taken in the installation and maintenance of the damper.

### INSPECTION

Inspect for shipping damage.

Inspect for proper size and model.

Inspect installed damper for proper orientation, as stated on damper label.

Inspect for obstructions which could interfere with free operation and complete closure.

Manually cycle the damper to verify proper operation.

### INSTALLATION

The basic intent of a proper installation is to secure the fire damper in, not to, the opening in such a manner as to prevent distortion and disruption of the damper operation by allowing the fire damper in openings to expand and the connecting duct to separate in the event of the collapse of the hanging system. The fire damper must be positioned within the masonry, block or gypsum wallboard fire barrier. Reference page F-4 for details of a recommended drywall partition installation.

### DAMPER TO SLEEVE ATTACHMENT

A sleeve shall be used of sufficient length to permit direct attachment of perimeter mounting angles. This damper can be supplied by the factory mounted in a sleeve. If the sleeve is not factory supplied, it must be attached on both sides of the damper by one of the following methods:

Secure with  $\frac{1}{4}$ " dia. bolts and nuts or by welding with beads  $\frac{1}{2}$ " in length, or with No. 10 steel sheet metal screws. Fasteners shall be 6" maximum on centers. Fasteners cannot be placed where they will interfere with damper operation. Gaps at corners between the damper and its sleeve must be small enough to prohibit the passage of an  $\frac{1}{8}$ " dia. rod through the entire depth of the gap between two damper panels and its sleeve.

### SLEEVE THICKNESS

Sleeves shall be the same gauge or heavier as the duct to which it is attached. Gauges shall conform to SMACNA or ASHRAE duct standards. Damper sleeve can be no thicker than 10 GA steel. On type C dampers, the sleeve must be 22 GA or heavier.

### EXPANSION CLEARANCE

The opening in the wall or floor for the fire damper shall be sized so as to provide expansion clearance between the sleeve and opening. Clearances do not vary with walls constructed of different materials. A minimum of  $\frac{1}{8}$ " per foot of overall damper/sleeve width and height is required. The maximum opening size shall not exceed  $\frac{1}{8}$ " per foot plus 1", minimum total clearance shall be at least  $\frac{1}{4}$ " larger than the overall assembly.

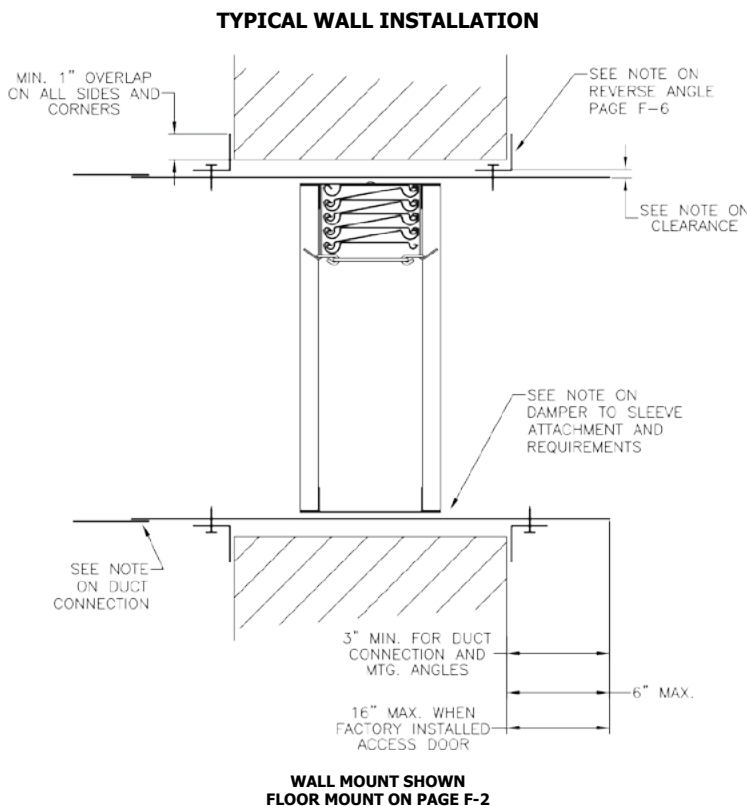

UNDERWRITERS' LABORATORIES (ULS55C)  
CLASSIFIED CEILING RADIATION DAMPERS  
FIRE RESISTANCE RATED 3 HOURS.  
FOR USE IN UL CLASSIFIED BUILDING  
MATERIALS RATED 3 HOURS OR LESS.

## AVI 75 - INSTALLATION INSTRUCTIONS - HORIZONTAL

### General Notes:

Aire Technologies Series 75 Fire Dampers are approved for use in static systems with a fire rating of less than 3 hours and are to be installed horizontally in accordance with the attitude label on the damper.

In testing Aire Technologies products, no caulking was used between the retaining angles and sleeve or between the retaining angles and partition. Application of such products in those areas shall only be done at the direction of the Authority Having Jurisdiction. The damper must be installed square. Twisting, racking, compressing, or stretching the damper into the opening is prohibited. Dust, dirt, paint, etcetera can inhibit the operation of the damper and can void the warranty. Special care must be taken in the installation and maintenance of the damper.

### INSPECTION

Inspect for shipping damage.

Inspect for proper size and model.

Inspect installed damper for proper orientation, as stated on damper label.

Inspect for obstructions which could interfere with free operation and complete closure.

Manually cycle the damper to verify proper operation.

### INSTALLATION

The basic intent of a proper installation is to secure the fire damper in, not to, the opening in such a manner as to prevent distortion and disruption of the damper operation by allowing the fire damper in openings to expand and the connecting duct to separate in the event of the collapse of the hanging system. The fire damper must be positioned within the masonry, block or gypsum wallboard fire barrier. Reference page F-4 for details of a recommended drywall partition installation.

### DAMPER TO SLEEVE ATTACHMENT

A sleeve shall be used of sufficient length to permit direct attachment of perimeter mounting angles. This damper can be supplied by the factory mounted in a sleeve. If the sleeve is not factory supplied, it must be attached on both sides of the damper by one of the following methods:

Secure with  $\frac{1}{4}$ " dia. bolts and nuts or by welding with beads  $\frac{1}{2}$ " in length, or with No. 10 steel sheet metal screws. Fasteners shall be 6" maximum on centers. Fasteners cannot be placed where they will interfere with damper operation. Gaps at corners between the damper and its sleeve must be small enough to prohibit the passage of an  $\frac{1}{8}$ " dia. rod through the entire depth of the gap between two damper panels and its sleeve.

### SLEEVE THICKNESS

Sleeves shall be the same gauge or heavier as the duct to which it is attached. Gauges shall conform to SMACNA or ASHRAE duct standards. Damper sleeve can be no thicker than 10 GA steel. On type C dampers, the sleeve must be 22 GA or heavier.

### EXPANSION CLEARANCE

The opening in the wall or floor for the fire damper shall be sized so as to provide expansion clearance between the sleeve and opening. Clearances do not vary with walls constructed of different materials. A minimum of  $\frac{1}{8}$ " per foot of overall damper/sleeve width and height is required. The maximum opening size shall not exceed  $\frac{1}{8}$ " per foot plus 1", minimum total clearance shall be at least  $\frac{1}{4}$ " larger than the overall assembly.

### TYPICAL HORIZONTAL INSTALLATION

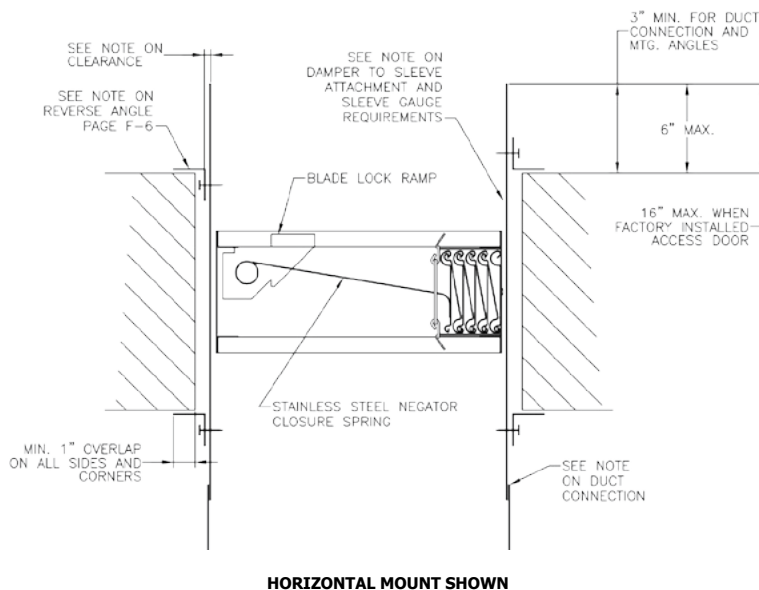

UNDERWRITERS 'LABORATORIES (UL55C)  
CLASSIFIED CEIUNG RADIATION DAWPERS  
FIRE RESISTENCE RATED 3 HOURS.  
FOR USE IN UL CLASSIF'IED BUILDING  
WATERIALS RATED 3 HOURS OR LESS.

## AVI 75 - INSTALLATION INSTRUCTIONS - TYPICAL

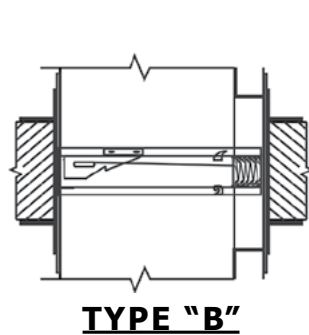
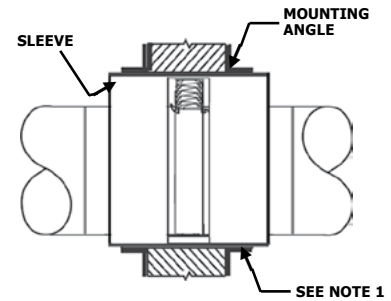
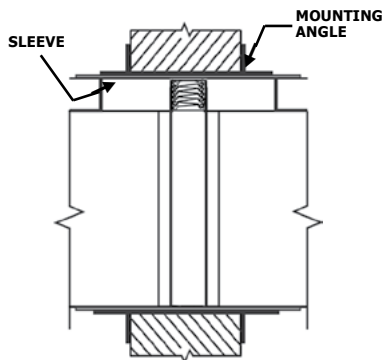
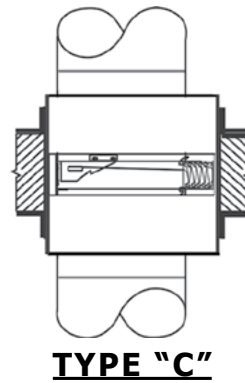
**TYPE "B"****TYPE "C"****TYPE "C"**

The factory supplied 22 GA collar to 18 GA cap connection on type "C" dampers is a breakaway connection under the following conditions:

1. Round unit duct diameters are no larger than 52".
2. Oval duct sizes on vertical dampers are no larger than 60" w x 60" h.
3. Oval duct sizes on horizontal dampers are no larger than 40" w x 60" h.
4. Duct gauges shall conform to the SMACNA or ASHRAE duct standards.
5. Duct diameters of 22" (559 mm) and smaller shall have three (3) No. 10 (4.8 mm) diameter sheet metal screws evenly spaced around the circumference of the duct.
6. Duct diameters greater than 22" and up shall have five (5) sheet metal screws evenly spaced around the circumference of the duct.
7. Dampers outside of these restrictions (ie) multiple dampers and special size and application dampers must use a 4" wide drawband connection as shown in the SMACNA Fire, Smoke, and Radiation Damper Installation Guide.



UNDERWRITERS 'LABORATORIES (ULS55C)  
CLASSIFIED CEIUNG RADIATION DAWPERS  
FIRE RESISTENCE RATED 3 HOURS.  
FOR USE IN UL CLASSIF'IED BUILDING  
WATERIALS RATED 3 HOURS OR LESS.

# AVI 75 - INSTALLATION INSTRUCTIONS

## for fire dampers installed into metal or wood framed fire barriers with ratings of less than 3 hours

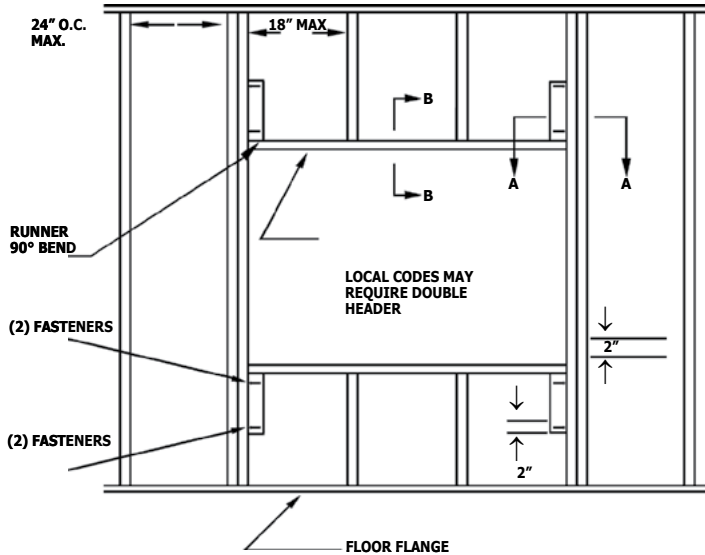

**NOTES:**

1. These illustrated partition designs have successfully been tested in conjunction with 1½-hour classified fire dampers. For additional designs, reference Underwriters Laboratories, Inc. Fire Resistance Directory. Specific framing requirements of openings may vary with the local authority that has jurisdiction. Specific framing requirements should be provided in the architectural and structural drawings.
2. Reference the damper's installation instructions regarding the approved method of attaching the damper to the sleeve, attaching the retaining angles to the sleeve, required expansion clearances, sleeve gauge, etc. Type of framing does not effect the stated required expansion clearance.
3. Gypsum panels surrounding the opening are to be fastened to all stud and runner flanges, 12" O.C. maximum.
4. When wooden studs are used, filler pieces must be installed around the entire opening. Filler pieces are optional when metal studs are used (consult local codes to determine if filler pieces are required). Filler pieces are to be double screwed (or nailed to wooden studs) on 12" max. centers to the web of runners and studs.
5. The Office of the California State Fire Marshal and other local jurisdictions require filler pieces around both wood and metal framed openings (no filler pieces around concrete or masonry openings). These codes also require a double header for wood framed openings, consult local code authorities.
6. Double jamb studding shown and required when opening width or height exceeds 36". Single jamb studding acceptable for openings 36" x 36" and smaller.

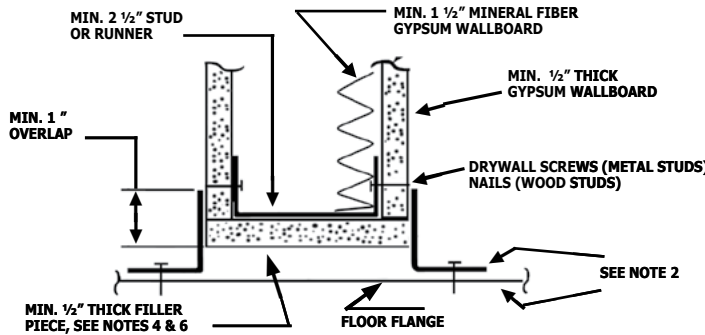

**1-HOUR RATED PARTITION WALL SECTION "B-B"**

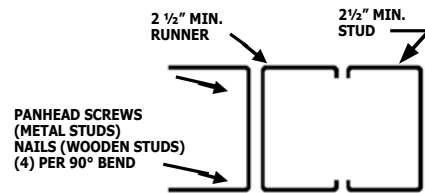
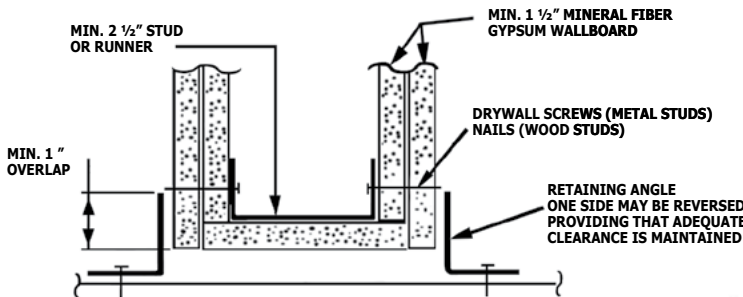

**SECTION "A-A"**



UNDERWRITERS 'LABORATORIES (ULS55C)  
CLASSIFIED CEIUNG RADIATION DAWPERS  
FIRE RESISTENCE RATED 3 HOURS.  
FOR USE IN UL CLASSIF'IED BUILDING  
WATERIALS RATED 3 HOURS OR LESS.

# AVI 75 - INSTALLATION INSTRUCTIONS

## breakaway connections

### Breakaway Style Transverse Joints

- Transverse joints illustrated at right have always been approved as breakaway connections. SMACNA testing has also approved the following variations as breakaway connections.
- Standing "S" joints can be applied with No. 10 sheet metal screws (through joint and duct) subject to the following limitations: Maximum 2 screws in each side and in bottom joint.

Transverse joints illustrated can be applied as top and bottom joints with Drive Slip - side joints in duct heights up to 20 inches.

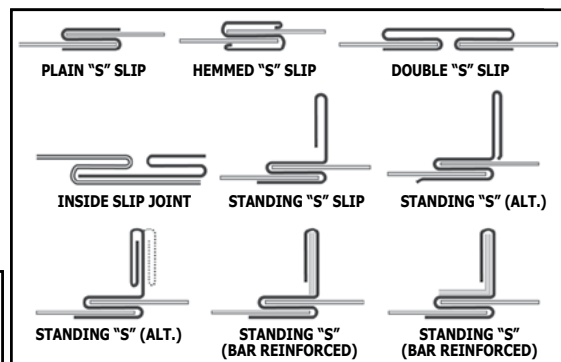

### Round and Oval Duct Breakaway

Round or flat oval ducts connected to type C damper collars may use no. 10 sheetmetal screws as follows:

Ducts to 22" wide (or dia.) and smaller may use 3 screws.

Ducts larger than 22" wide (or dia.) may use 5 screws.

NOTE: All breakaway connections described may have duct sealant applied in accordance with SMACNA recommendations.

### Connections

### Manufactured Flanged System Breakaway Connections

Flanged connection systems manufactured by Ductmate, Ward and Nexus are approved as breakaway connections when installed as illustrated.

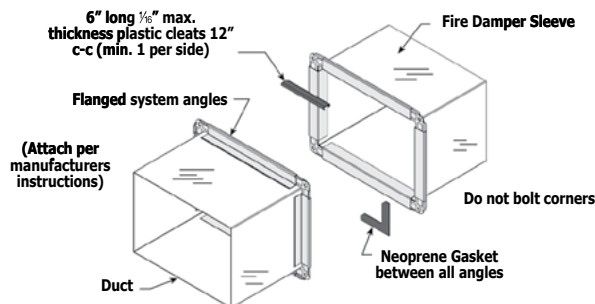

### Proprietary Flange System Breakaway Connections (TDC by Lockformer, TDF by Engle)

TDC and TDF systems are approved as breakaway connections when installed as described in the TDC or TDF addendum to the SMACNA Duct Construction Standards except the corners may not be bolted. Standard 5" metal clip may be used with spacing as shown in diagram.

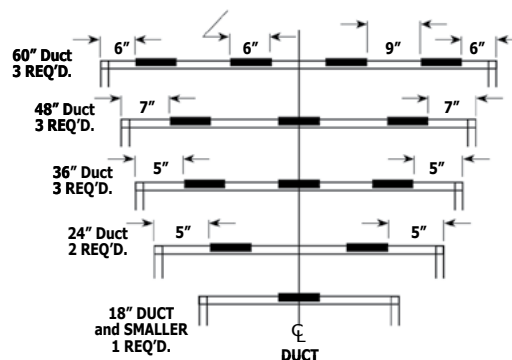
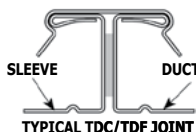

UNDERWRITERS ' LABORATORIES (ULS55C)  
 CLASSIFIED CEIUNG RADIATION DAWPERS  
 FIRE RESISTENCE RATED 3 HOURS.  
 FOR USE IN UL CLASSIF'IED BUILDING  
 WATERIALS RATED 3 HOURS OR LESS.

## AVI 75 - INSTALLATION INSTRUCTIONS

### ATTACHING FIRE DAMPERS TO SLEEVES

Fire Dampers must be attached to sleeves as shown in fig. 1. All four sides of the damper frame must be attached to the sleeve with one row of attachments on each side of the blade channel. Attachments must be spaced a maximum of 6" on centers and a maximum of 2" from corners. A minimum of 4 attachments (2 on each side of the blade channel) per side (16 per damper) are required. One of the methods of attachment shown below must be used.

- Tack or spot welds
- 1/2" weld beads
- No. 10 sheet metal screws
- 1/4" bolts and nuts

### SECURING FIRE DAMPER AND SLEEVES TO WALL AND FLOOR OPENING

Fire damper and sleeve assemblies must be installed in wall and floor openings using retaining angles on each side of the wall or floor as described below:

- Retaining angles must be a minimum of 16 gauge steel and have a minimum of 1 1/2" X 1 1/2" legs.
- Retaining angles must be attached to the sleeve using the procedures and methods described in F-24. The angles must be attached to all 4 sides of the sleeve with butt joints at each corner. A minimum of two attachments are required on each side, top and bottom. The angles need not be attached to each other at the corners.
- Retaining angles must completely cover the clearance space between the sleeve and the wall/floor opening, plus overlap the wall/floor a minimum of 1". This coverage includes all corners (fig. 2).
- Retaining angles should not be fastened to the wall/floor material. The angles should only sandwich the wall/floor and allow for damper/sleeve expansion during periods of intense heat.
- For grille installation, angle legs may be reversed and one leg inserted into the wall/floor opening providing the required clearance is maintained between angle leg fasteners and the wall/opening.

### CONNECTING DUCTS TO FIRE DAMPER SLEEVE

Any Duct connection other than breakaway is considered rigid. The connections shown on F-22 are considered breakaway. Factory furnished duct collars on type C fire dampers are also considered breakaway.

### MULTIPLE SECTION FIRE DAMPERS

Multi-section dampers are to be assembled from single sections no greater than 60" x 60". Multi-section dampers are to be no greater than 120" x 120" for vertical installations or 120" x 60" for horizontal installations using 1/2" bead welds, #10 sheet metal screws or 1/4" bolts and nuts.

When multiple sections are shipped unassembled, installer shall fasten dampers together using one of those means.

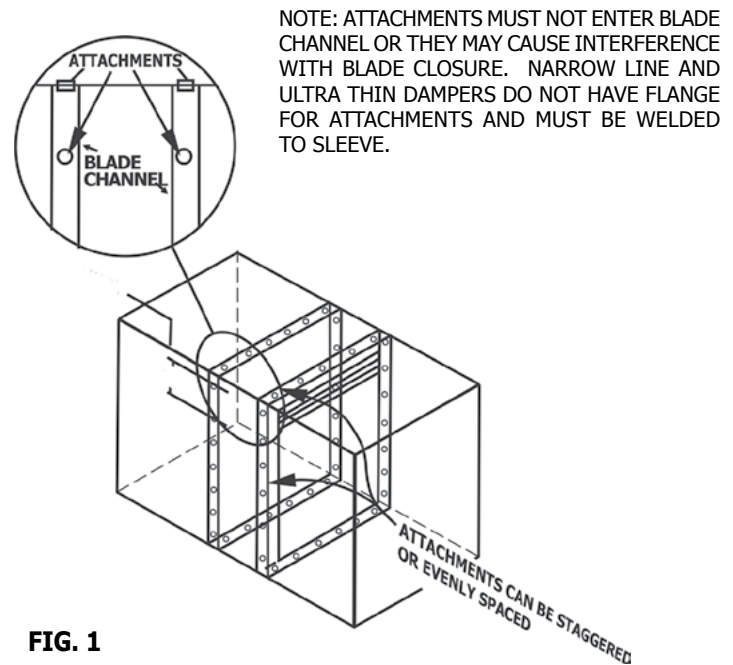

FIG. 1

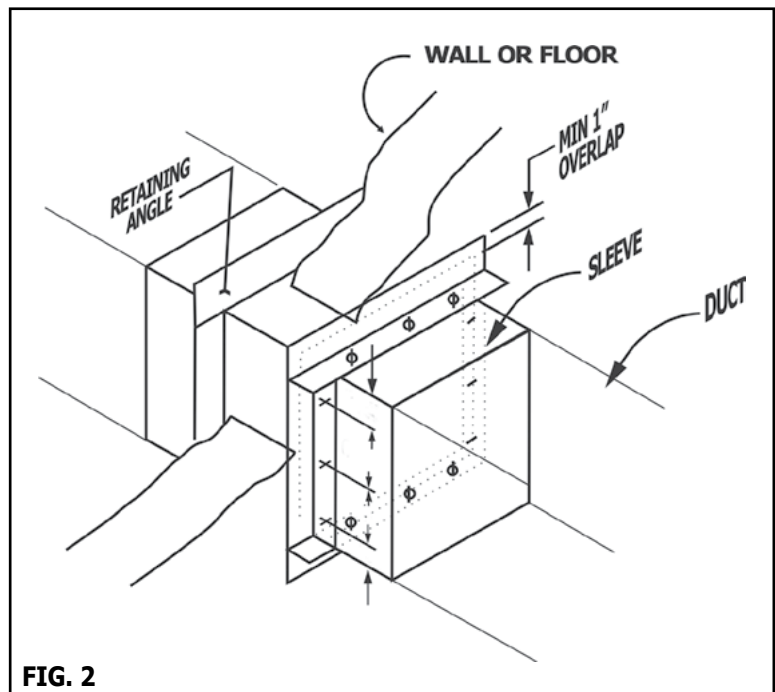

FIG. 2



UNDERWRITERS 'LABORATORIES (ULS55C)  
CLASSIFIED CEIUNG RADIATION DAWPERS  
FIRE RESISTENCE RATED 3 HOURS.  
FOR USE IN UL CLASSIF'IED BUILDING  
WATERIALS RATED 3 HOURS OR LESS.

# AVI 75 - INSTALLATION INSTRUCTIONS

## **MOUNTING ANGLES**

Secure mounting angles to the sleeve and not to the wall or floor. Mounting angles to frame the four sides of the sleeve on both faces. When reverse mounting angles are used the size of the opening must be increased to maintain the specified expansion clearance between the angle/fasteners and the opening. Angles shall be a minimum of 1½" x 1½" x 16 ga. on dampers 36" x 50" and smaller. For dampers greater than 36" x 50", angles to be a minimum of 1½" x 1½" x 14 ga. Fasten angles to the sleeve using ¼" dia. bolts and nuts or by welding with beads ½" in length, or with No. 10 steel sheet metal screws. Fasteners or weld beads shall be 6"(single section) or 4"(multi section) maximum on centers.

## **ACCESS**

Suitable access must be provided for damper inspection and servicing. Where it is not possible to achieve sufficient size access, it will be necessary to install a removable section of duct.

## **DUCT CONNECTION**

The installation of the damper and all duct connections to the damper sleeve shall conform to NFPA-90A and the SMACNA Fire, Smoke and Radiation Damper Installation Guide. All duct connections shall also conform to UL555. Connecting ducts shall not be continuous but shall terminate at the damper sleeve. Duct connections to the sleeve will be either of the breakaway or rigid types, breakaway types are listed below. The following determines if the connections are to be rigid or breakaway. For rigid type duct connections, sleeve shall be a minimum of 16 ga. on dampers not exceeding 36" wide or 24" high or 24" diameter and 14 ga. on larger units. Dampers supplied with thinner sleeves will require a breakaway connection of the following type. Plain "S" slip, double "S" slip shown below. Ductmate type-connections as shown on page 12, all connections not listed as breakaway shall be considered as rigid. Breakaway joints of the types shown below shall have no more than two No. 10 (4.8mm) diameter sheet metal screws on each side and on the top and bottom located in the center of the slip pocket and shall penetrate both sides of the slip pocket. Breakaway joints of the type shown below are permitted on the top and bottom of horizontal ducts (vertical dampers) with flat slips not exceeding 20 inches (508 mm) in length on the sides.



**PLAIN "S" SLIP**



**DOUBLE "S" SLIP**



**INSIDE SLIP JOINT**



**HEMMED "S" SLIP**



**STANDING "S" SLIP**



**STANDING "S" SLIP  
(BAR REINFORCED)**



**STANDING "S" SLIP  
(ANGLE REINFORCED)**



**STANDING "S" SLIP**

## **MAINTENANCE**

Dampers shall be maintained in intervals as stated in NFPA-90A Appendix B, unless local codes require more frequent inspections. Check the fuse link, check the stainless steel closure spring where furnished, cycle damper and check for free operation and complete closure, clean with mild detergent or solvent, secure damper open with fusible link.

## **SINGLE-SIDE RETAINING ANGLE INSTALLATION OPTION**

**Application:** Single section dampers may be installed using single-side retaining angles in lieu of conventional 2-sided retaining angle installation up to a maximum section size of 36" x 36". Single-side retaining angles may be field fabricated or factory supplied and may be installed in metal stud, wood stud, concrete or masonry partitions.

**Installation:** Single-sided retaining angles should be a minimum of 1-½" x 1-½" x 16 gauge steel. The retaining angles should be attached to the damper sleeve (18 gauge maximum thickness and 22 gauge minimum thickness) with ¾" #10 screws at 3" maximum spacing and 2" maximum from the corners. Coarse threaded standard drywall screws with a minimum length of 1-5/8" should be used to attach the retaining angle to steel or wood framed walls with a maximum screw spacing of 3". Attach retaining angle to concrete or masonry partitions with 3/16" concrete screws with a maximum spacing of 12". Ensure that the annular space between the damper sleeve and wall opening is maintained according to UL555 requirements (1/8" per lineal foot of damper). The close plane of the damper blades must remain within the plane of the wall. Single-side retaining angles shall be installed on the top side of a ceiling/floor for horizontal mounting.



UNDERWRITERS' LABORATORIES (UL555C)  
CLASSIFIED CEILING RADIATION DAMPERS  
FIRE RESISTANCE RATED 3 HOURS.  
FOR USE IN UL CLASSIFIED BUILDING  
MATERIALS RATED 3 HOURS OR LESS.

## AVI 75 - INSTALLATION INSTRUCTIONS

**transfer openings and duct terminals  
for 1½ hour and 3 hour curtain fire dampers  
series 75 and series 05**

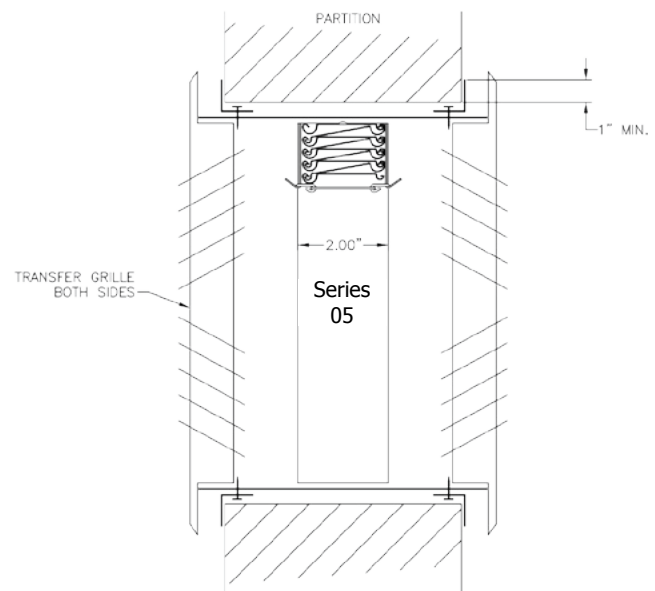
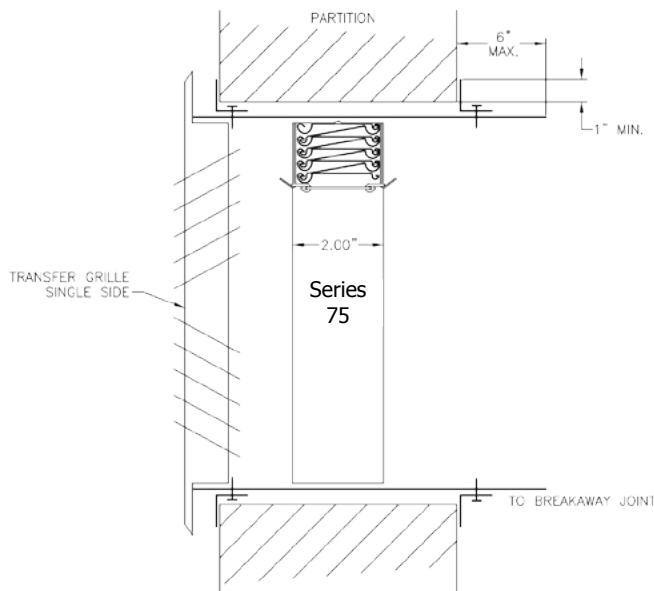

1. Perimeter mounting angles are to be a minimum of 1½" X 1½" X 16 ga. on dampers 36 X 50 and smaller. For dampers greater than 36 X 50, angles to be a minimum of 1½" X 1½" X 14 ga.
2. Grille to flange fasteners cannot penetrate the fire wall.
3. Secure angles to sleeve only, so as to frame the wall opening. Fasten to the sleeve only using the same means as required for fastening the damper to the sleeve.
4. Grille to flange attachment by means of ¼" dia. pop rivets, #8 sheet metal screws or #8 bolts and nuts. Fasteners to be plated steel or stainless steel, minimum two fasteners per side.



UNDERWRITERS 'LABORATORIES (ULS55C)  
CLASSIFIED CEIUNG RADIATION DAWPERS  
FIRE RESISTENCE RATED 3 HOURS.  
FOR USE IN UL CLASSIF'IED BUILDING  
WATERIALS RATED 3 HOURS OR LESS.



## AVI 75 - OPERATION AND MAINTENANCE

### **OPERATION AND MAINTENANCE OF FIRE DAMPERS**

All dampers shall be tested and inspected 1 year after installation. After the first year, dampers shall be inspected every 4 years, with the exception of hospitals, where the inspections shall be every 6 years. In testing the dampers, the fusible link shall be removed to ensure full closure and lock in place. The damper must not be blocked from closure in any way. Once the testing is complete, the fusible link shall be reinstalled. If any paint is on the link, or if the link has been damaged, it shall be replaced with another fusible link of equal temperature, load rating, and size. Please see NFPA 80 Section 19.4 for more details.

### **MAINTENANCE OF FIRE DAMPERS**

Typically dampers do not require maintenance. However, if cleaning is necessary, use a mild detergent and dry completely. Do not use lubricants as they can attract dust and debris.

<b>SYMPTOM</b>	<b>POSSIBLE CAUSE</b>	<b>CORRECTIVE ACTION</b>
Damper does not open or close completely	Frame is "racked" causing blades to bind.	Adjust frame so that it is plumb and square
	Dust and/or debris	Clean with mild detergent and dry
Link separated	Excessive heat/cold	Replace link



UNDERWRITERS 'LABORATORIES (ULS55C)  
 CLASSIFIED CEILING RADIATION DAMPERS  
 FIRE RESISTANCE RATED 3 HOURS.  
 FOR USE IN UL CLASSIFIED BUILDING  
 MATERIALS RATED 3 HOURS OR LESS.