

Aisin AF 33-5 Automatic Transaxle Introduction

Course #17341.10B

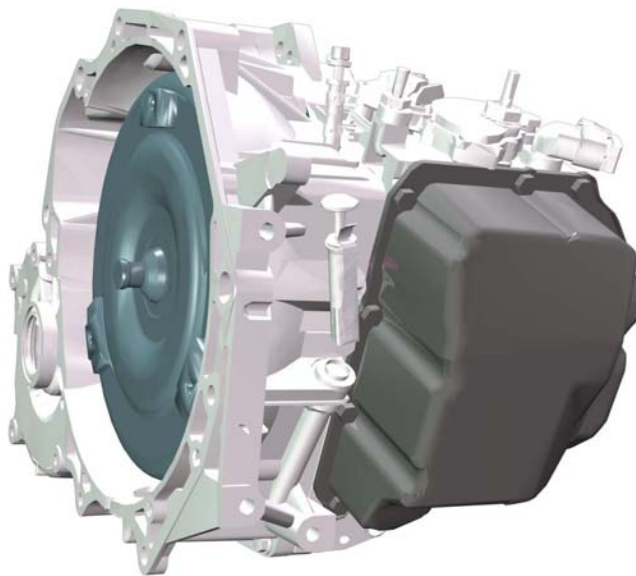

Service
Know-How

Caution

In order to reduce the chance of personal injury and/or property damage, carefully observe the following information:

The service manuals of General Motors Corporation are intended for use by professional, qualified technicians. Attempting service procedures without the appropriate training, tools, and equipment could cause personal injury, vehicle damage, or improper vehicle operation. Proper vehicle service is important to the safety of the service technician and to the safe, reliable operation of all motor vehicles. If a replacement part is needed, use the same part number or an equivalent part. Do not use a replacement part of lesser quality.

The service manuals contain effective methods for performing service procedures. Some of the procedures require the use of tools that are designed for specific purposes.

Accordingly, any person who intends to use a replacement part, a service procedure, or a tool that is not recommended by General Motors, must first establish that there is no jeopardy to personal safety or the safe operation of the vehicle.

The service manuals contain Cautions and Notices that must be observed carefully in order to reduce the risk of injury. Improper service may cause vehicle damage or render the vehicle unsafe. The Cautions and Notices are not all-inclusive. General Motors cannot possibly warn of all the potentially hazardous consequences that may result by not following the proper service procedures.

The service manuals cover service procedures for vehicles that are equipped with Supplemental Inflatable Restraints (SIR). Failure to observe all SIR Cautions and Notices could cause air bag deployment, personal injury, or otherwise unneeded SIR repairs. Refer to the SIR component and wiring location views in Restraints before performing a service on or around SIR components or wiring.

If multiple vehicle systems are in need of repair, including SIR, repair the SIR system first to reduce the risk of accidental air bag deployment and personal injury.

Aisin AF33-5 Automatic Transaxle

Foreword

This manual contains diagnostic and service information regarding the Aisin AF33-5 Automatic Transaxle. It includes features that make it unique, basic operation and service strategies, maintenance and tools required for service. It will also include a guide to distinguish which repairs can be completed on-vehicle vs. repairs that require bench service. Always refer to the applicable vehicle Service Information and appropriate Dealer Technical Service Bulletins for additional information regarding specific system operation and diagnostic/repair procedures.

When this manual refers to a brand name, a number, or a specific tool, you may use an equivalent product in place of the recommended item, unless instructed otherwise.

All information, illustrations, and specifications in this manual are based on the latest product information available at the time of publication approval. General Motors reserves the right to make changes at any time without notice.

When technical assistance is required, call the Technical Assistance Center at 1-877-446-8227.

Published by General Motors Corporation, Service Operations, Warren, Michigan 48090-9008.

© 2004 GENERAL MOTORS CORPORATION. ALL RIGHTS RESERVED. Information cutoff date 02-13-04.

LITHO IN U.S.A.

No part of this book may be reproduced, stored in any retrieval system, or transmitted in any form or by any means (including but not limited to electronic, mechanical, photocopying, and recording) without prior written permission of General Motors Corporation. This applies to all text, illustrations, tables and charts.

All product names throughout this book are trademarks or registered trademarks of their respective holders.

Table of Contents

1. Introduction	1-1
Aisin AF33-5 Automatic Transaxle	1-1
Transaxle Identification Information	1-2
AF33-5 Basic Specifications	1-3
Required Tools	1-4
2. Automatic Transaxle Components	2-1
Major Mechanical Components	2-1
Major Electrical Components	2-2
Major Hydraulic Components	2-3
3. Adaptive Learn Functions	3-1
Transaxle Adaptive Functions	3-1
Transaxle Adaptive Learn Procedure	3-2
Uphill Mode Feature	3-4
Downhill Mode Feature	3-4
4. Unique Features	4-1
Clutch-to-Clutch Strategy	4-1
Fluids	4-2
Three Planetary Gear Sets	4-3
Four Piece Valve Body	4-4
5. Valve Body Components	5-1
Valves Located in the Front Control Valve Body Assembly	5-1
Valves Located in the Middle Control Valve Body Assembly	5-1
Valves Located in the Rear Control Valve Body Assembly	5-2
Valves Located in the Rear No. 2 Control Valve Body Assembly	5-2
6. Solenoid Operation	6-1
Five Shift Solenoids	6-1
Three Linear Solenoids	6-2
Emergency Mode	6-3
7. Apply Components	7-1
Clutch Pack	7-1
Sprags	7-1
Seven Friction Clutch Packs	7-2
Low Clutch and Second Clutch Sprags	7-2
9. Service Items: On-Vehicle	8-1
On-Vehicle Service Items	8-1
On-Vehicle Procedures	8-1
Fluid Level Check Procedure	8-2
Third Gear Band Anchor Bolt	8-3
Line Pressure Check	8-4
Park/Neutral Position Switch	8-5
Park/Neutral Position Switch Adjustment	8-6
9. Service Items: Bench	9-1
Bench Service Items	9-1
Filter Replacement	9-2
Front Differential Bearing Pre-Load	9-3
Bearing Torque Specification	9-4
Measure Forward and Direct Clutch End Play	9-5
Gaskets	9-6

1. Introduction

Aisin AF33-5 Automatic Transaxle

In the 2005 Model Year, Chevrolet will introduce a new model called the Equinox. The transaxle used in the Equinox is the Aisin AF33-5, which will be available in both front wheel and all wheel drive configurations.

The Aisin AF33-5 is a fully automatic, five speed, electronically controlled transaxle. It can be operated in any one of six different modes:

- P – Park, enabling the engine to be started while preventing the vehicle from rolling either forward or backward.
- R – Reverse, enabling the vehicle to be operated only in the rearward direction.
- N – Neutral, enabling the engine to start and operate without driving the vehicle. If necessary, this position should be selected to restart the engine while the vehicle is moving.
- D – Drive range, which should be used for all normal driving conditions for maximum efficiency and fuel economy.
- L4 – Intermediate range, which can be used for conditions where it may be more desirable to use four gear ratios, such as when towing a trailer or driving on hilly terrain. This range will prevent the transaxle from shifting above fourth gear.
- L2 – Low range, which adds more performance for congested traffic and hilly terrain. This range will prevent the transaxle from shifting above second gear.

Many procedures listed in this General Motors Service Know-How release are documented in SI online documents and bulletins. Always check Service Information for updated documentation.

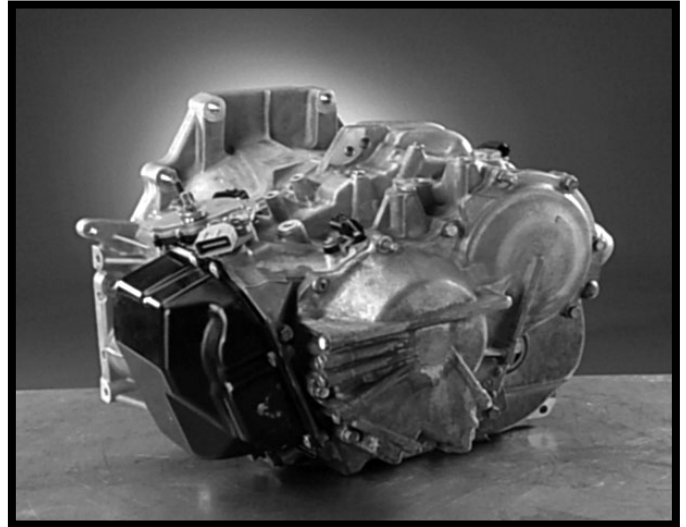

Figure 1-1, The Aisin AF33-5 Automatic Transaxle



Figure 1-2, The 2005 Chevrolet Equinox

1. Introduction

Transaxle Identification Information

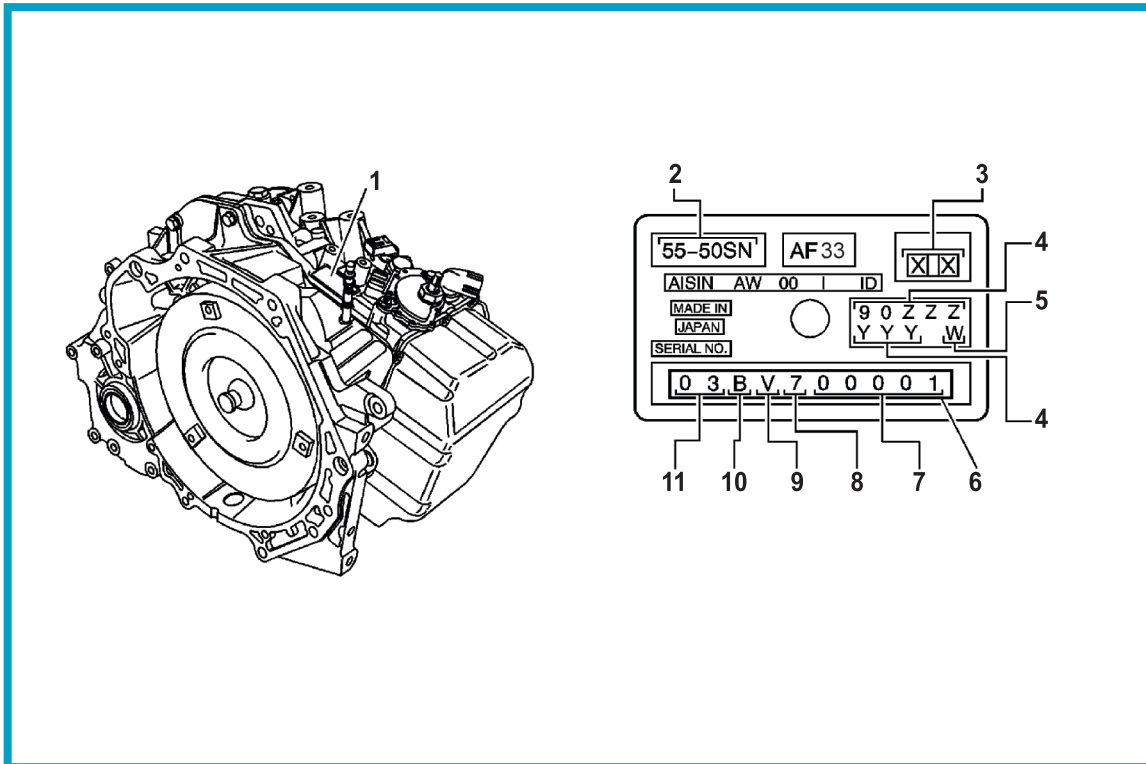

Figure 1-3, Transaxle Identification Information

1. Transaxle I.D. Location
2. Model Number
3. GM I.D. Code
4. GM Part Number
5. Calibration Code
6. AW Production Unit Number
7. Serial Number During the Month of Manufacture
8. Assembly Line Code
9. Model of Transaxle, V = 55-50SN
10. Month of Manufacture, A = Jan, B = Feb, etc
11. Year of Manufacture, 03 = 2003

AF33-5 Basic Specifications

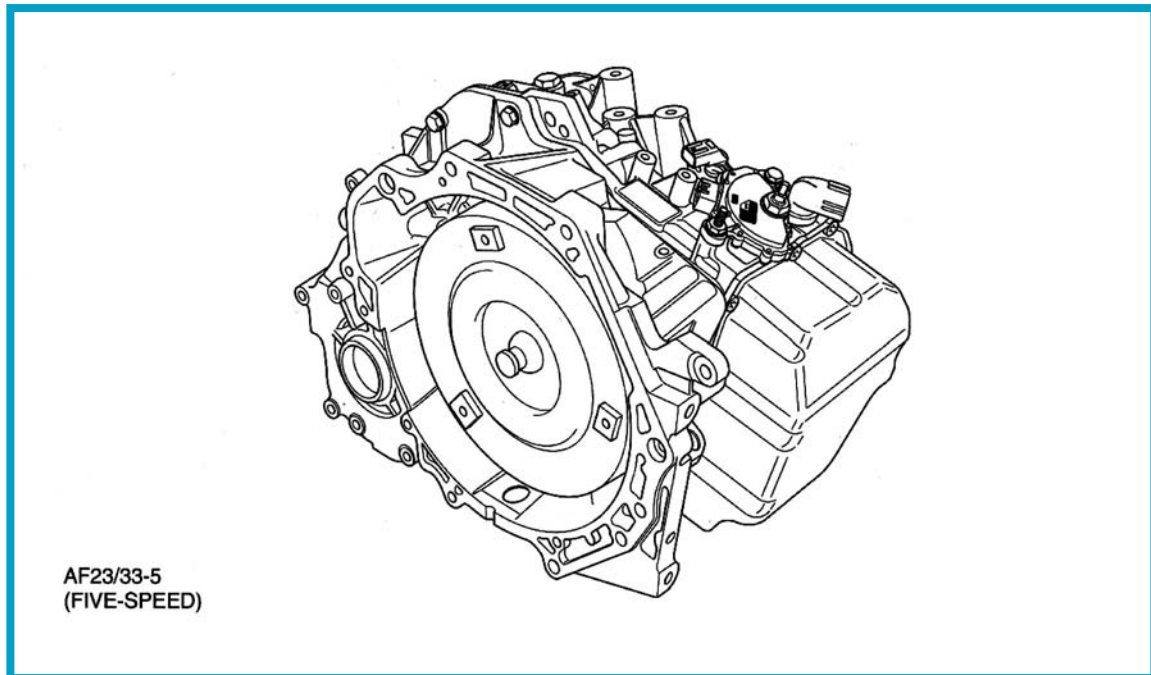

Figure 1-4, Aisin AF33-5 Basic Specifications

- **Country of Origin**
Japan
- **Transaxle Drive**
Transverse front wheel drive
All wheel drive
- **Transaxle Type**
Fully automatic, electronically-controlled, five-speed, front wheel or all wheel drive transaxle with a torque converter clutch
- **Gear Ratios**

1st	4.685
2nd	2.942
3rd	1.923
4th	1.301
5th	1.000
Rev	3.177
- **Trailer Towing Capacity**
2,500 lb (1,134 kg)
- **Transmission Fluid Type**
T-IV (GM P/N 88900925)
- **Transaxle Weight**
AF33-5 - Wet: 198.4 lb (90 kg)
- **Six Position Quadrant**
P - Park
R - Reverse
N - Neutral
D - Drive
L4 - Low 4
L2 - Low 2
- **Pressure Taps Available**
Line Pressure

1. Introduction

Required Tools

Tools	Tool Number
3rd Gear Band Anchor Bolt Socket	DT 47599
Rotational Torque Adapter	DT 47687
Pressure Gage	J 21867
Transmission Line Pressure Adapter	J 21867-50
Clutch Spring Compressor	J 23327
Booster and Clutch Pack Compressor	J 23456
Servo Piston/Clutch Spring Compressor	J 25024-A
Snap Ring Remover	J 28585
Oil Pump Seal Installer	J 35582
Connector Test Adapter Kit	J 35616-A/BT-8637
Cooler Flush Adapter	J 35944-440
Fascia Retainer Remover	J 36346
Output Shaft Assembly Remover and Installer	J 38868
Coast Clutch Spring Compressor	J 41236
Cooler Line Seal Installer/Remover	J 41239
Output Shaft Seal Installer	J 44809
Seal Remover	J 45000
Universal Clamp Press	J 45053
Transmission Oil Cooling System Flush and Flow Test Tool	J 45096
Removal Bridge	J 45124
Holding Fixture	J 45159
Differential Bearing Race Remover	J 45160
Manual Shift Bearing Replacer	J 45161
Spring Compressor Bridge	J 45164
Dial Indicator Extension Rod - 8"	J 45166
Differential Bearing Race Installer	J 45184
Bore Gage Set	J 45185
Forward and Direct Clutch Spring Compressor	J 45186
Differential Output Shaft Oil Seal Installer	J 45187
Dial Indicator Set	J 45200
Transmission Indicator Alignment Tool	J 45404
Slide Hammer Adapter	J 6125-1B

2. Automatic Transaxle Components

Major Mechanical Components

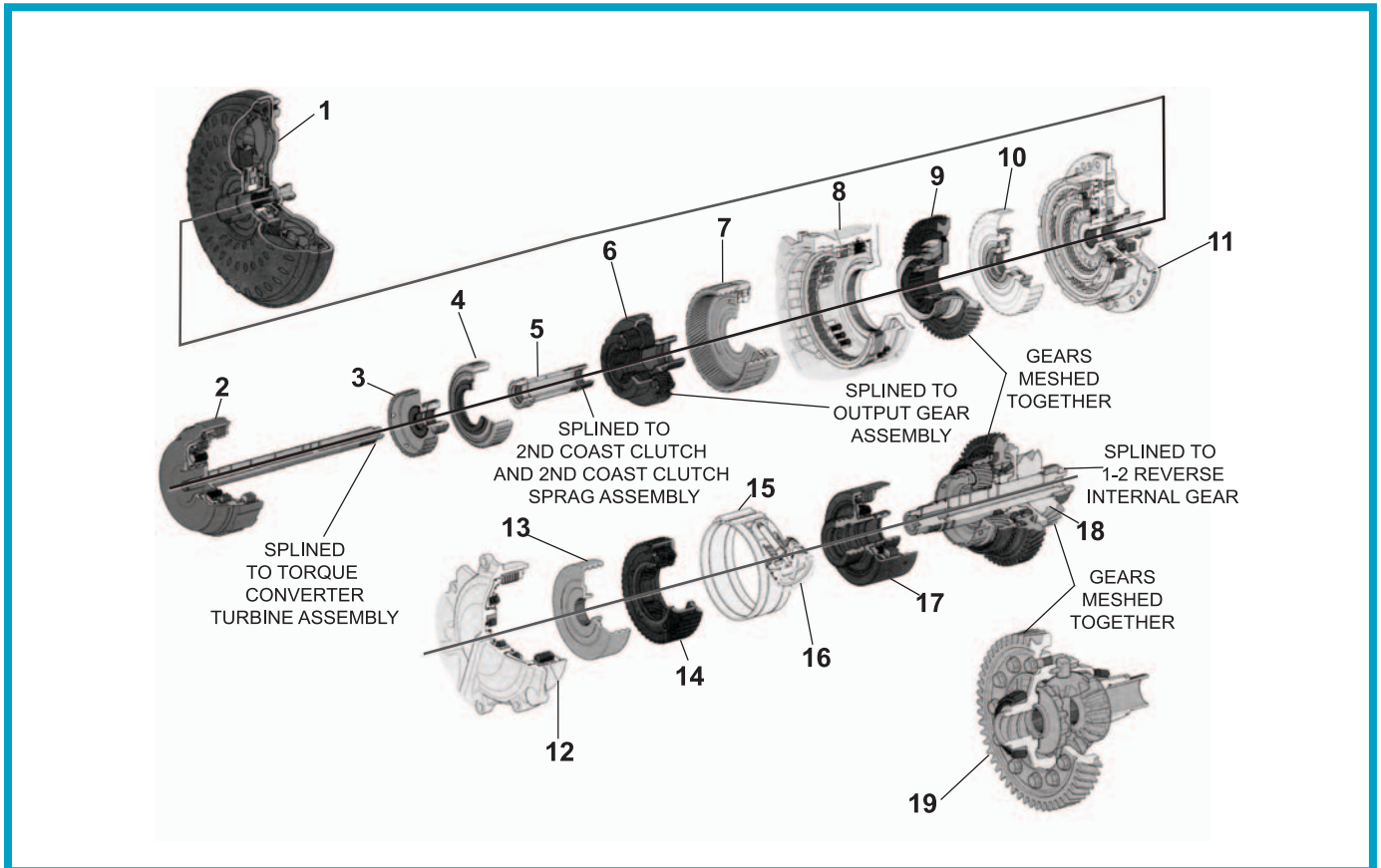

Figure 2-1, Location of Major Mechanical Components

The major mechanical components of the Aisin AF33-5 are as follows:

1. Torque Converter Assembly
2. Forward and Direct Clutch Assembly
3. Rear Sun Gear Assembly
4. Rear Internal Gear
5. Front Sun Gear
6. Front Carrier Assembly
7. Front Internal Gear and Low Clutch Sprag Assembly
8. Low and Reverse Clutch Plates and Disc Assembly
9. Output Gear Assembly
10. Second Coast Clutch, Second Clutch Hub, and Second Clutch Sprag Assembly
11. Automatic Transmission Fluid Pump, Second Coast Clutch, and Second Clutch Assembly
12. 1-2 Reverse Clutch Assembly
13. 1-2 Reverse Internal Gear
14. 1-2 Reverse Carrier Gear Assembly
15. 3rd Gear Band Assembly
16. 3rd Gear Band Servo Piston Assembly
17. 4-5 Clutch Assembly
18. Front Differential Transfer Drive Gear Assembly
19. Front Differential Assembly

2. Automatic Transaxle Components

Major Electrical Components

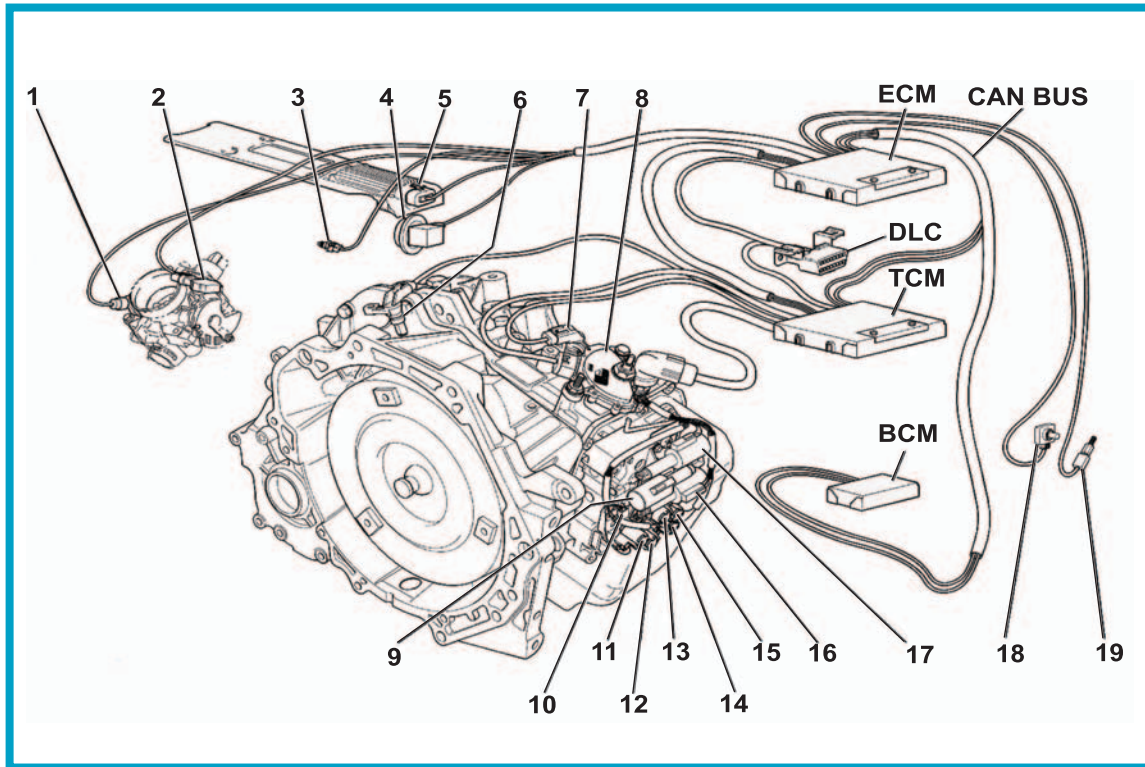

Figure 2-2, Location of Major Electrical Components

The major electrical components of the Aisin AF3-5 are as follows:

- | | |
|---|--|
| 1. Throttle Position (TP) Sensor | 12. Reverse Shift Solenoid Valve Assembly (S5) – Green |
| 2. Manifold Absolute Pressure (MAP) Sensor | 13. Reverse, 1st Shift Solenoid Valve Assembly (SI) – Black |
| 3. Engine Coolant Temperature (ECT) Sensor | 14. 1-2, 2-3, Reverse Shift Solenoid Valve Assembly (S3) – Dark Gray |
| 4. Cruise Control Information | 15. 3-4, 4-5 Shift Solenoid Valve Assembly (S4) – Blue |
| 5. Engine Speed (Ignition Module) | 16. Shift Pressure Control Solenoid Valve Assembly (SLS) – Green |
| 6. Automatic Transaxle Output Speed Sensor (OSS) Assembly | 17. Lock Up Pressure Control Solenoid Valve Assembly (SLU) – Black |
| 7. Automatic Transaxle Input Speed Sensor (ISS) Assembly | 18. Accelerator Pedal Position (APP) Sensor |
| 8. Park/Neutral Position Switch Assembly | 19. TCC Brake Switch |
| 9. Line Pressure Control Solenoid Valve Assembly (SLT) – Blue | |
| 10. Automatic Transmission Fluid Temperature (TFT) Sensor | |
| 11. 2-3, 3-4 Shift Solenoid Valve Assembly (S2) – Light Gray | |

Major Hydraulic Components

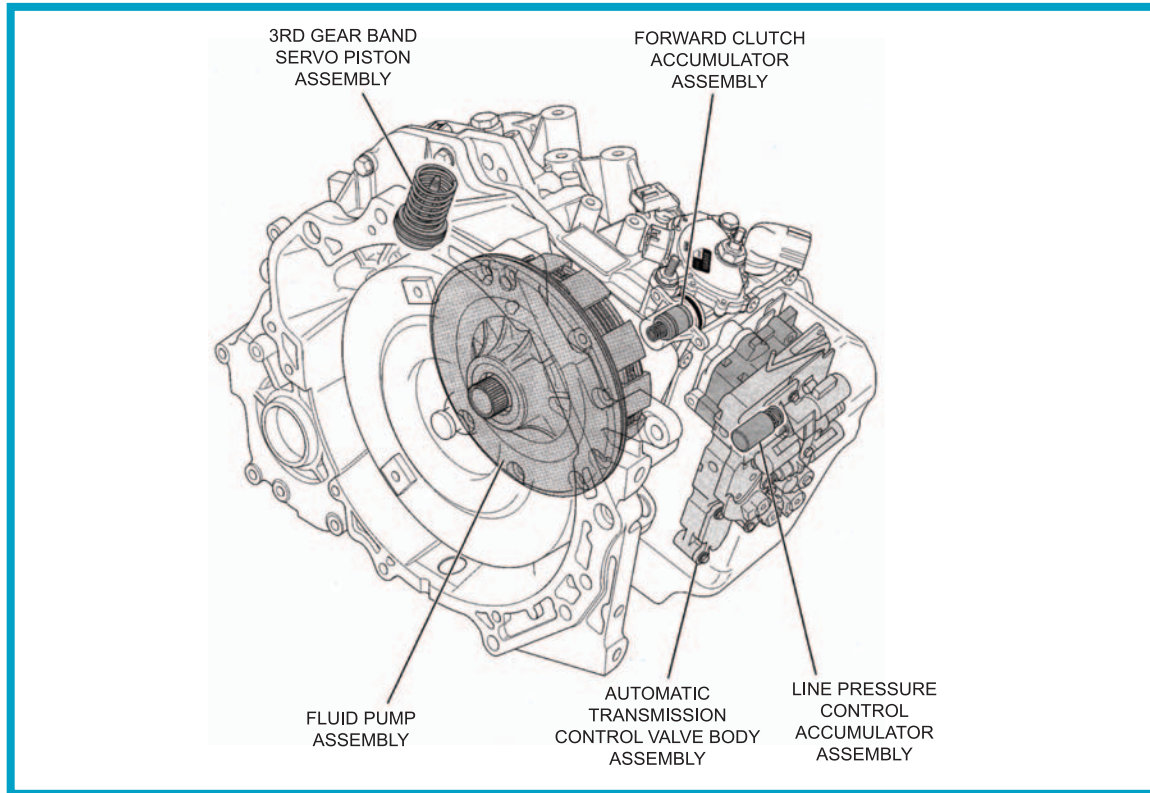

Figure 2-3, Location of Major Hydraulic Components

The major hydraulic components of the Aisin AF33-5 are as follows:

- Fluid Pump Assembly
- Automatic Transaxle Control Valve Body Assembly (4-piece)
 - Front Control Valve Body
 - Middle Control Valve Body
 - Rear Control Valve Body
 - Rear No. 2 Control Valve Body
- Line Pressure Control (SLT) Accumulator Assembly
- Forward Clutch (C1) Accumulator Assembly
- 3rd Gear Band (B4) Servo Piston Assembly

3. Adaptive Learn Functions

Transaxle Adaptive Functions

Programming within the Transaxle Control Module (TCM) allows for automatic adjustments in shift pressure that are based on the changing characteristics of the transaxle components.

As the apply components within the transaxle wear, shift time (the time required to apply a clutch) increases. In order to compensate for this wear, the TCM adjusts trim pressure by controlling the line pressure control solenoid valve in order to maintain the originally calibrated shift timing.

The automatic adjusting process is referred to as "adaptive learning" and it is used to assure consistent shift feel plus increase transaxle durability.

The TCM monitors the Automatic Transaxle Input Speed Sensor (A/T ISS) and the Automatic Transaxle Output Speed Sensor (A/T OSS) during commanded shifts to determine if a shift is occurring too fast (harsh) or too slow (soft) and adjusts the line pressure control solenoid valve signal to maintain a set shift feel.

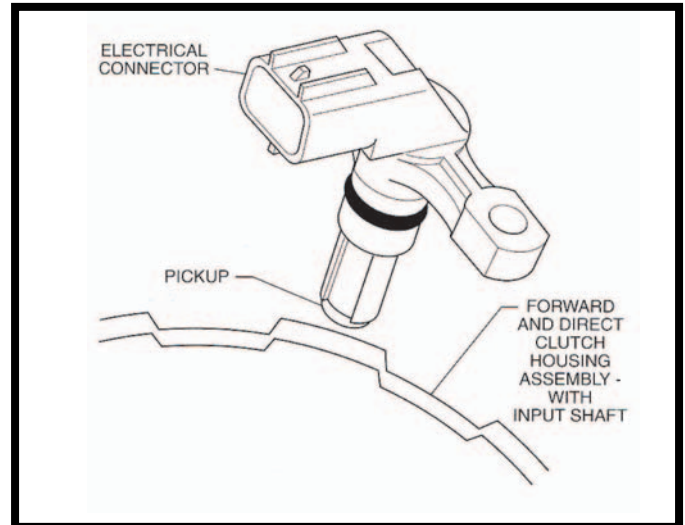

Figure 3-1, The Automatic Transaxle Input Speed Sensor (ISS)

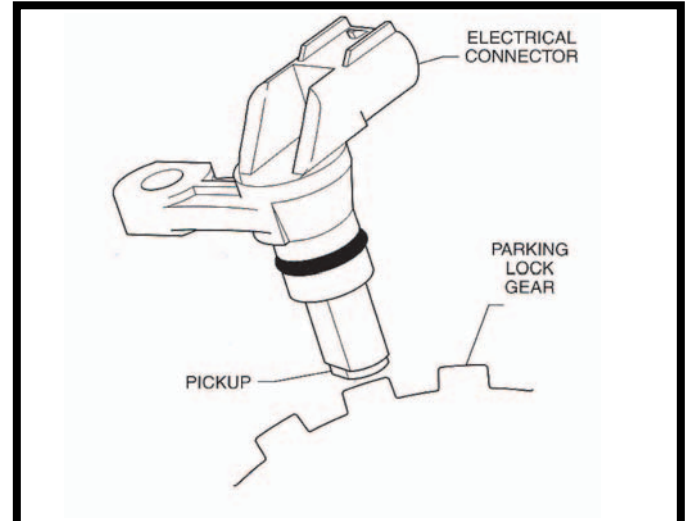

Figure 3-2, The Automatic Transaxle Output Speed Sensor (OSS)

3. Adaptive Learn Functions

Transaxle Adaptive Learn Procedure

Perform the transaxle adaptive learn procedure after any of the following service procedures:

- Transaxle Control Module (TCM) Replacement
- TCM Calibration Change
- Control Valve Body Replacement
- Transaxle Overhaul
- Transaxle Replacement

The adapt function learn procedure is based on a number of transaxle shifts, rather than driving time or distance.

— IMPORTANT —

Perform all steps of the adaptive learn procedure. Engine flare during shifting or harsh shifts will occur if not done correctly. When performing the up/down shifting during 2-3 and 3-4 upshifts, small shift flare may occur the first or second time, depending on transaxle internal tolerances.

1. Warm the transaxle fluid until 150°F – 230°F (65°C – 110°C). The adaptive learn procedure will not work unless transaxle fluid is the correct temperature.
2. Reset the transaxle adaptive learns using a scan tool. Go to the Transmission Special Functions then Trans. Output Controls menu and select Reset Transmission Adapts.
3. Perform the following steps for the garage shifts adaptive learn:
 - a. Apply the parking brake and the foot brake.
 - b. Shift from NEUTRAL to REVERSE and keep in REVERSE for 3 seconds.
 - c. Shift from REVERSE to NEUTRAL.
 - d. Repeat steps **b** and **c** five times.
 - e. Shift from NEUTRAL to DRIVE and keep in DRIVE for 3 seconds.
 - f. Shift from DRIVE to NEUTRAL.
 - g. Repeat steps **e** and **f** five times.
4. Perform the following steps for the up/down shifting adaptive learn.
 - a. Drive the vehicle in DRIVE with light (15-20%) throttle until above 50 km/h (31 mph) in 4th gear.
 - b. Decelerate and apply the brakes until vehicle comes to a stop. Brake the vehicle so that it takes at least 14 seconds.
 - c. Repeat steps **a** and **b** five times.
 - d. Drive the vehicle in DRIVE with medium (50-55%) throttle until shifts into 5th gear.
 - e. Decelerate and apply the brakes until vehicle comes to a stop. Brake the vehicle slowly, so that each downshift occurs.
 - f. Repeat steps **d** and **e** five times.

5. Perform the following steps for 2-1 manual down shift adaptive learn.
 - a. Drive the vehicle in L4 until over 25 km/h (16 mph) in 2nd with any throttle position.
 - b. Decelerate, shift from L4 to L2 manually and stop the vehicle.
 - c. Repeat steps **a** and **b** ten times.
6. Confirm shift quality.

— IMPORTANT—

If shift quality does not improve, ensure the TCM has the correct transmission calibration.

3. Adaptive Learn Functions

Uphill Mode Feature



Figure 3-3, Uphill Mode Helps Maintain Vehicle Speed on an Incline

The first time a customer experiences the sensation of the uphill mode in action, they may believe that there is a problem with the vehicle.

When traveling uphill, the Aisin AF33-5 shifts accordingly to maintain a constant speed. The driver does not need to increase pressure on the accelerator in order to climb a hill. The transaxle will continuously adjust itself by downshifting and upshifting to maintain the vehicle speed. This is normal operation.

Downhill Mode Feature



Figure 3-4, Downhill Mode Helps Maintain Vehicle Speed on a Decline

This mode is sometimes called auto-grade braking. Downhill mode, similar to the uphill mode, will occasionally cause customers to believe there is a shifting issue with their new vehicle.

In downhill mode, the Aisin AF33-5 applies clutches to maintain a constant speed. The customer will feel engine braking, a process that uses the compression of the engine to slow the vehicles descent of the hill along with an increase in engine RPMs. Again, this is normal operation.

4. Unique Features

Clutch-to-Clutch Strategy

RANGE	GEAR	RATIO	REV. 1ST SS VALVE (S1)	2-3, 3-4 SS VALVE (S2)	1-2, 2-3 REV SS VALVE (S3)	3-4, 4-5 SS VALVE (S4)	REVERSE SS VALVE (S5)	SECOND CLUTCH (B2)	SECOND COAST CLUTCH (B1)	SECOND COAST SPRAG (F1)	LOW CLUTCH SPRAG (F2)	LOW AND REVERSE CLUTCH (B3)	FORWARD CLUTCH (C1)	DIRECT CLUTCH (C2)	4-5 CLUTCH (C3)	3RD GEAR BAND (B4)	1-2 REVERSE CLUTCH (B5)
PARK	P	—	OFF	OFF	OFF	OFF	OFF										APPLIED
REVERSE	R	3.177	OFF*	OFF	ON*	OFF	ON*					APPLIED		APPLIED			APPLIED
NEUTRAL	N	—	OFF	OFF	OFF	OFF	OFF										APPLIED
D	1	4.685	ON	OFF	ON	OFF	OFF				HOLDING		APPLIED				APPLIED
	2	2.942	OFF	ON	ON	OFF	OFF	APPLIED	APPLIED	HOLDING			APPLIED				APPLIED
	3	1.923	OFF	ON	ON	ON	OFF	APPLIED	APPLIED	HOLDING			APPLIED			APPLIED	
	4	1.301	OFF	ON	OFF	ON	OFF	APPLIED	APPLIED	HOLDING			APPLIED		APPLIED		
	5	1.000	OFF	OFF	OFF	ON	OFF	APPLIED					APPLIED	APPLIED	APPLIED		
	Emergency	1.000	OFF	OFF	OFF	OFF	OFF	APPLIED						APPLIED	APPLIED	APPLIED	
L4	1	4.685	ON	OFF	ON	OFF	OFF				HOLDING		APPLIED				APPLIED
	2	2.942	OFF	ON	ON	OFF	OFF	APPLIED	APPLIED	HOLDING			APPLIED				APPLIED
	3	1.923	OFF	ON	ON	ON	OFF	APPLIED	APPLIED	HOLDING			APPLIED			APPLIED	
L2	1 E/B	4.685	ON	OFF	ON	OFF	ON				HOLDING	APPLIED	APPLIED				APPLIED
	2	2.942	OFF	ON	ON	OFF	OFF	APPLIED	APPLIED	HOLDING			APPLIED				APPLIED

* If vehicle speed is above 7 km/h (4mph), the TCM commands the shift solenoid valves to inhibit reverse.

Figure 4-1, The Clutch-to-Clutch Strategy

The clutch-to-clutch process brings one apply element on and takes another apply element off at the exact same moment in order to achieve the next gear.

For example, when shifting from fourth to fifth gear, the second coast clutch is turned off while at the same time, the direct clutch is turned on.

This differs from other automatic transaxle operation in that most will continue to add apply components for each upshift, without turning other apply components off.

This clutch-to-clutch strategy is unique to the Aisin AF33-5.

4. Unique Features

Fluids



Figure 4-2, T-IV Fluid

Under normal operation, fluid changes are not necessary. The Aisin AF33-5 is considered a filled-for-life transaxle.

T-IV is the only fluid used in the AF33-5.

— CAUTION —

NEVER use Dexron III in place of, or mixed with, the specified T-IV synthetic fluid.

Failure to use the specified T-IV fluid will result in poor shifting quality, and eventually transaxle failure.

- Type:
T-IV (synthetic) GM P/N 88900925
DO NOT USE DEXRON III
- Capacity (approximate):
8.2 qt (7.8L)

— SPECIAL NOTE —

If the transaxle is subjected to what is considered severe duty, fluid maintenance may be required. Severe duty may warrant a fluid change at 50,000 miles. Refer to the fluid service/maintenance schedule found in SI for more detailed information.

Three Planetary Gear Sets

A unique feature of the Aisin AF33-5 is its use of three planetary gear sets.

Planetary gear sets are used in automatic transaxles as the primary method of multiplying the torque, or twisting force, of the engine (reduction). Planetary gear sets are also used to reverse the direction of rotation, function as a coupling for direct drive, and provide an overdrive gear ratio.

The three sets of planetary gears found in the Aisin AF33-5 are (Figure 4-3):

1. Front Carrier Assembly
2. Front Differential Transfer Drive Gear Carrier Assembly
3. 1-2, Reverse Carrier Gear Assembly

The front carrier assembly is unique because it resembles a combination of two gear sets. This gear set consists of two sets of pinion gears (one long and one short) in one carrier assembly, two sun gears (front sun gear and a rear sun gear assembly) and two internal gears (front internal gear and rear internal gear). The front and rear sun gears are in constant mesh with the long pinion gears. The long pinion gears are in constant mesh with the short pinion gears and the rear internal gear. The short pinion gears are in constant mesh with the front internal gear. The end result is that the two sets of pinions produce the various gear ratios.

The front differential transfer drive gear carrier assembly and the 1-2, reverse carrier gear assembly both operate in a manner typical of planetary gear sets found in other General Motors transmissions and transaxles.

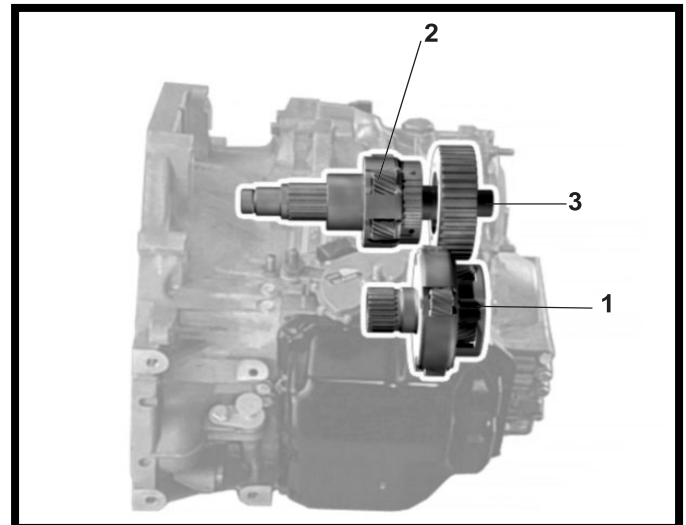

Figure 4-3, Three Planetary Gear Sets

4. Unique Features

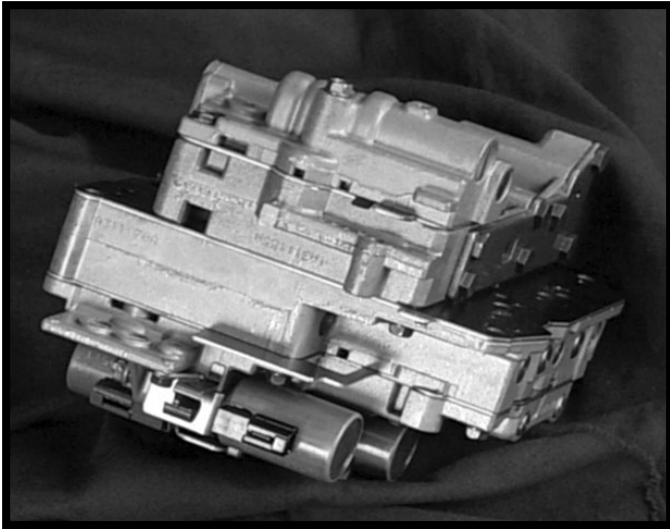

Figure 4-4, The Valve Body

Four Piece Valve Body

The valve body in the Aisin AF33-5 is designed in four pieces. However, it is only available as a complete unit for service. The only components that can be independently serviced are the shift solenoids and the manual valve.

The valve body consists of the following pieces:

- Front Control Valve Body
- Middle Control Valve Body
- Rear Control Valve Body
- Rear No. 2 Control Valve Body

Remember, the valve body **CANNOT** be opened for service.

It may be disassembled for inspection, but, once it is opened for any reason, it **MUST** be replaced.

5. Valve Body Components

Valves Located in the Front Control Valve Body Assembly

The following valves are all found within the front control valve body assembly (Figure 5-1):

- Pressure Relief Valve
- Solenoid Modulator Valve
- Forward Clutch Control Valve
- Neutral Relay Valve
- Second Coast Clutch Control Valve
- Line Pressure Control Solenoid Valve Assembly
- Torque Converter Clutch Lock Up Pressure Control Solenoid Valve Assembly
- Shift Pressure Control Solenoid Valve Assembly
- Reverse, 1st Shift Solenoid Valve Assembly
- 2-3, 3-4 Shift Solenoid Valve Assembly
- 1-2, 2-3, Reverse Shift Solenoid Valve Assembly
- 3-4, 4-5 Shift Solenoid Valve Assembly
- Reverse Shift Solenoid Valve Assembly
- Check Valves

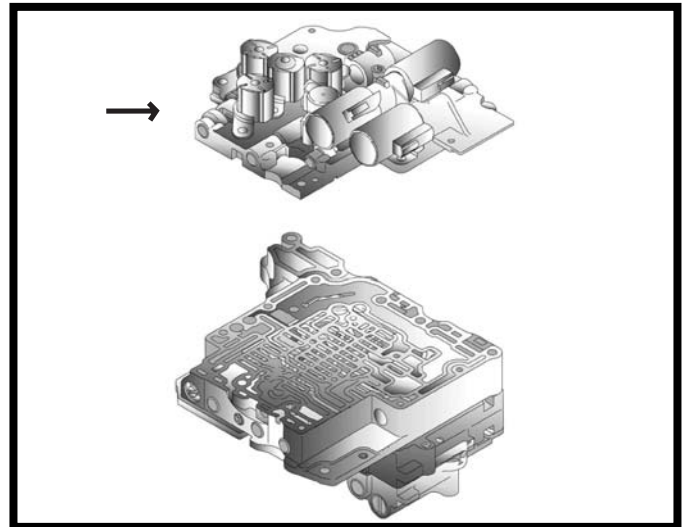

Figure 5-1, The Front Control Valve Body Assembly

Valves Located in the Middle Control Valve Body Assembly

The following valves are all found within the middle control valve body assembly (Figure 5-2):

- Manual Valve
- Solenoid Valve Train
 - Solenoid Relay Valve Plunger
 - Solenoid Relay Valve
- Cooler By-Pass Valve
- Torque Converter Clutch Check Valve
- 3rd Gear Band Release Valve
- U1 Shift Valve
- M1 Shift Valve
- U2 Shift Valve
- Primary Regulator Valve Train
 - Primary Regulator Valve
 - Primary Regulator Valve Plunger

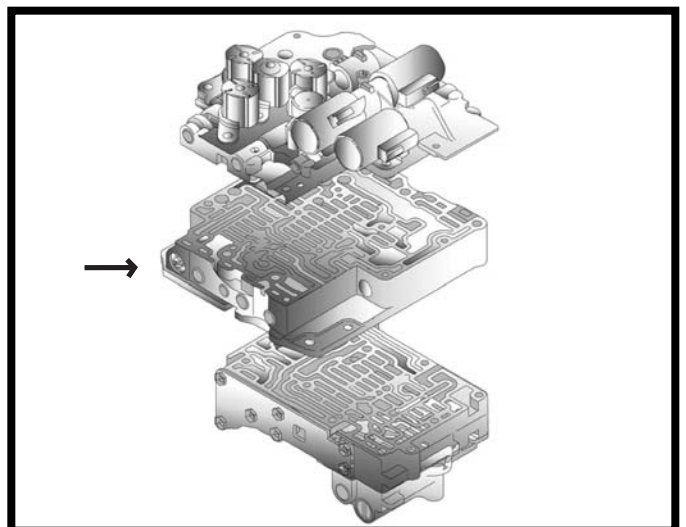

Figure 5-2, The Middle Control Valve Body Assembly

5. Valve Body Components

Valves Located in the Rear Control Valve Body Assembly

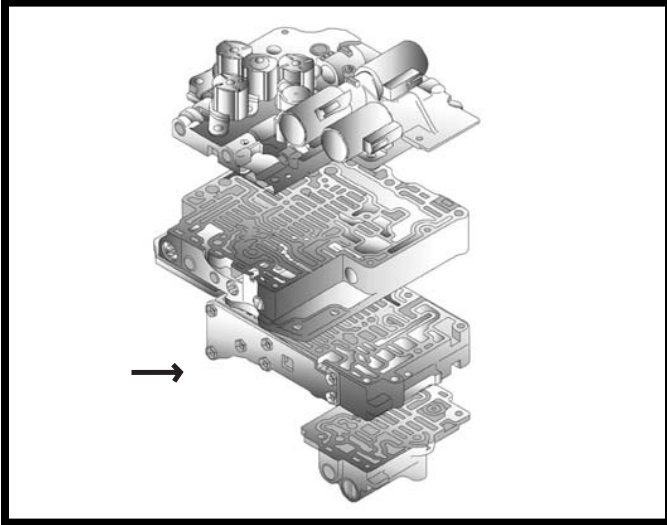

Figure 5-3, The Rear Control Valve Body Assembly

The following valves are all found within the rear control valve body assembly (Figure 5-3):

- Lock Up Relay Valve Train
 - Lock Up Relay Control Valve Plunger
 - Lock Up Relay Valve
- 1-2 Reverse Clutch Control Valve
- 3rd Gear Bank Control Valve
- Shift Pressure Relay Valve
- M2 Shift Valve
- Shift Pressure Control Valve Train
 - Shift Pressure Control Valve
 - Shift Pressure Control Valve Plunger
- Secondary Regulator Valve
- Line Pressure Control Accumulator Assembly

Valves Located in the Rear No. 2 Control Valve Body Assembly

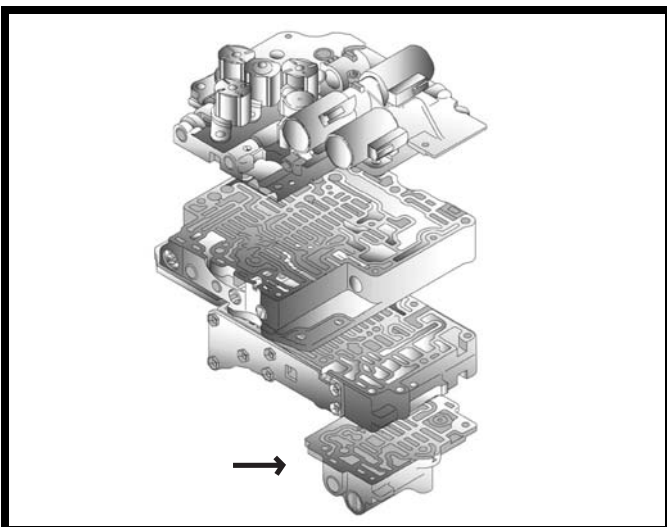

Figure 5-4, The Rear No. 2 Control Valve Body Assembly

The following valves are all found within the rear No. 2 control valve body assembly in the Aisin AF33-5 (Figure 5-4):

- Torque Converter Clutch Check Valve
- Second Clutch Control Valve
- Lock Up Control Valve Train
 - Lock Up Control Valve
 - Lock Up Control Valve Plunger

6. Solenoid Operation

Five Shift Solenoids

The function of the five shift solenoids is to apply and release the clutch packs by locking-up the planetary gear sets in order to achieve different gear ratios. These five shift solenoids are identified as:

- Reverse, First Shift Solenoid Valve, or S1
- 2-3, 3-4 Shift Solenoid Valve, or S2
- 1-2, 2-3 Shift Solenoid Valve, or S3
- 3-4, 4-5 Shift Solenoid Valve, or S4
- Reverse Shift Solenoid Valve, or S5

Shift solenoid operation relies on a mixture of solenoid ON/OFF signals to properly route fluid (Figure 6-1).

RANGE	GEAR	RATIO	REV, 1ST SS VALVE (S1)	2-3, 3-4 SS VALVE (S2)	1-2, 2-3, REV SS VALVE (S3)	3-4, 4-5 SS VALVE (S4)	REVERSE SS VALVE (SS)
PARK	P	—	OFF	OFF	OFF	OFF	OFF
REVERSE	R	3.177	OFF*	OFF	ON*	OFF	ON*
NEUTRAL	N	—	OFF	OFF	OFF	OFF	OFF
D	1	4.685	ON	OFF	ON	OFF	OFF
	2	2.942	OFF	ON	ON	OFF	OFF
	3	1.923	OFF	ON	ON	ON	OFF
	4	1.301	OFF	ON	OFF	ON	OFF
	5	1.000	OFF	OFF	OFF	ON	OFF
	EMERGENCY	1.000	OFF	OFF	OFF	OFF	OFF
L2	1	4.685	ON	OFF	ON	OFF	OFF
	2	2.942	OFF	OFF	ON	OFF	OFF
	3	1.923	OFF	OFF	ON	ON	OFF
L4	1 ENGINE BRAKING	4.685	ON	OFF	ON	OFF	ON
	2	2.942	OFF	ON	OFF	OFF	OFF

The reverse, 1st; 2-3, 3-4; and 3-4, 4-5 shift solenoid valves are normally-open.

The 1-2, 2-3, reverse; and reverse shift solenoid valves are normally-closed.

The reverse shift solenoid valve is also energized (ON) during 2-3 and 3-4 shifts.

* = If vehicle speed is greater than 4 mph (7 km/h), the TCM commands the shift solenoid valves to inhibit reverse

Figure 6-1, Shift Solenoid ON/OFF Signals

6. Solenoid Operation

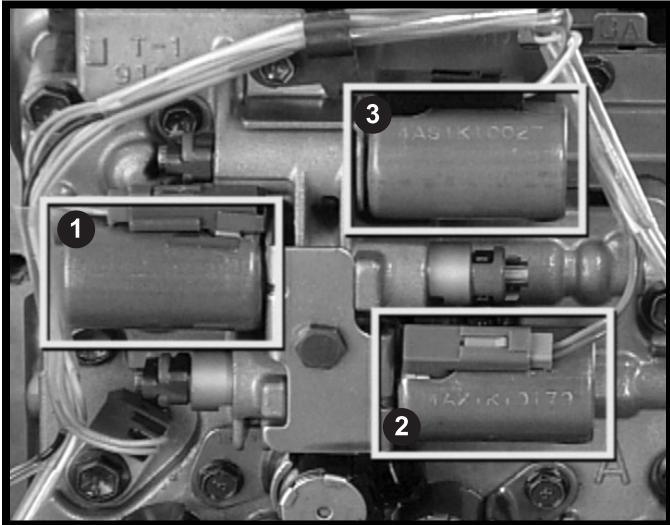

Figure 6-2, Three Linear Solenoids

Three Linear Solenoids

All three linear solenoids are TCM controlled. The TCM varies the current flow to the linear solenoids so that as current flow decreases, pressure increases and as current flow increases, the solenoid output pressure decreases.

The three linear solenoids are (Figure 6-2):

1. Line Pressure Control Solenoid
2. Shift Pressure Control Solenoid
3. Torque Converter Clutch Lock-Up Pressure Control Solenoid

The line pressure control solenoid maintains consistent pressure for proper transaxle operation.

The shift pressure control solenoid maintains shift feel by controlling the hydraulic pressure for the application, or release, of the friction components. (This is a part of the transaxle adaptive functions.)

The torque converter clutch lock-up pressure control solenoid controls the apply and release pressure of the torque converter clutch, and the low and reverse clutch during low range first gear operation.

In some publications, these solenoids are abbreviated as:

- **SLT** = Line Pressure Control Solenoid
- **SLS** = Shift Pressure Control Solenoid
- **SLU** = Torque Converter Clutch Lock-Up Pressure Control Solenoid

Emergency Mode

All five of the shift solenoid valves will be de-energized (turned OFF) if the entire electronic control system of the transaxle ever becomes disabled.

In "Emergency Mode" the vehicle will only operate in fifth gear, regardless of the forward gear selection.

The torque converter clutch lock-up pressure control solenoid valve is also turned OFF during "Emergency Mode" to prevent torque converter clutch apply.

This function will allow the driver to safely operate the vehicle until the condition can be corrected.

If the transaxle is in Drive Range when "Emergency Mode" is enabled, the transaxle will assume a fifth gear hydraulic power flow state, with the following exceptions:



Figure 6-3, In Emergency Mode, the MIL Will Illuminate

— SPECIAL NOTE —

In "Emergency Mode" the vehicle will also operate in Reverse, Park, or Neutral if selected by the driver. The only forward gear permitted at this time will be fifth, regardless of the gear selector position.

3-4, 4-5 Shift Solenoid Valve Assembly (S4) De-Energized

- 3-4, 4-5 Shift Solenoid (SS) Valve Assembly (S4)
The 3-4, 4-5 SS valve assembly is de-energized, allowing fluid pressure in the S4 signal fluid circuit to exhaust through the solenoid.
- Solenoid Relay Valve
Solenoid Relay Valve fluid pressure exhausts into the sump.

Lock Up Pressure Control Solenoid Valve (SLU) De-Energized

- Lock Up Pressure Control Solenoid Valve (SLU)
The lock up pressure control solenoid valve is de-energized, allowing lock up control fluid and TCC signal fluid to exhaust through the solenoid.

7. Apply Components

Clutch Pack

The Aisin AF33-5 incorporates both mechanical and hydraulic apply components within its design.

The hydraulic "apply" and "release" components, such as clutches and bands, provide automatic gear range shifting (Figure 7-1).

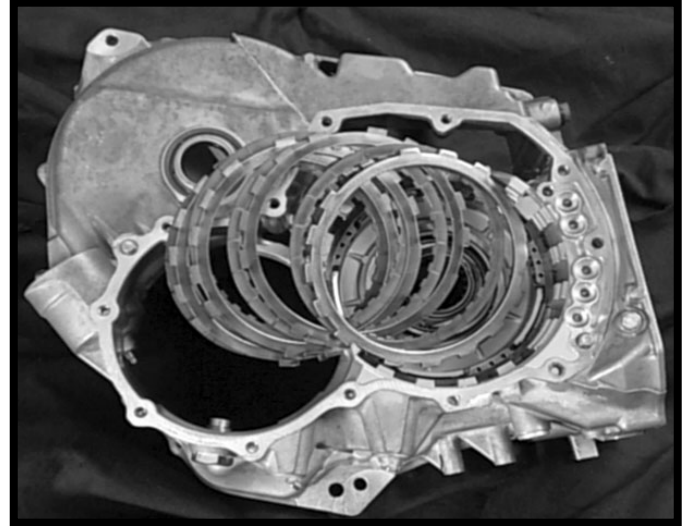

Figure7-1, Clutch Packs

Sprags

The mechanical "apply" and "release" components, such as sprag clutches (Figure 7-2), react to the hydraulically "applied" components by "holding" or "releasing" the planetary gearset components as necessary.

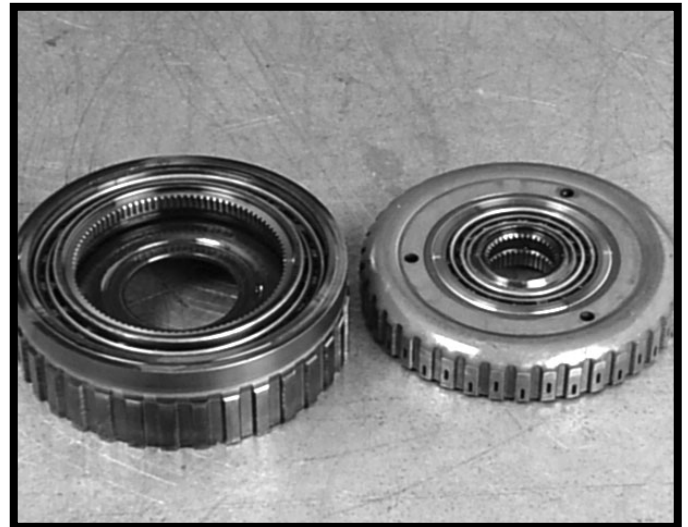

Figure 7-2, Sprags

7. Apply Components

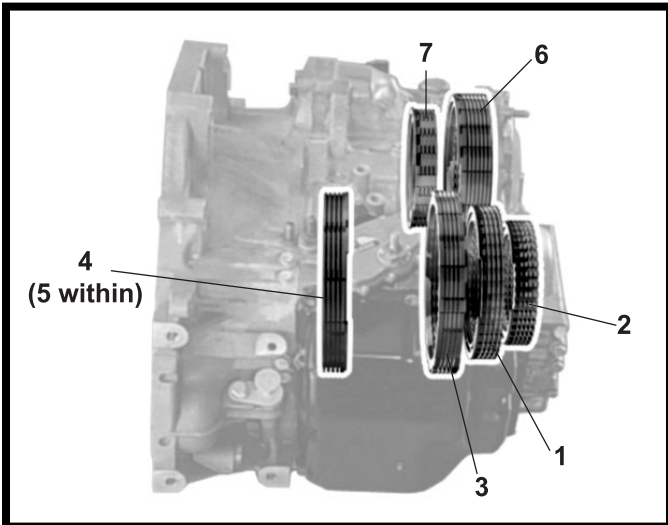

Figure 7-3, The Aisin AF33-5 Uses Seven Friction Clutch Packs

Seven Friction Clutch Packs

These multiple disc, hydraulic clutches provide the grip that is required to hold the rotating components in order to obtain the proper gear ratio (Figure 7-3).

The Seven Friction Clutch Packs are:

1. Forward Clutch
2. Direct Clutch
3. Low And Reverse Clutch
4. Second Clutch
5. Second Coast Clutch
6. 1-2 Reverse Clutch
7. 4-5 Clutch

Sprags are mechanical clutches, or holding devices, that consist of elements assembled between inner and outer races.

When the sprags are combined together with the hydraulic friction clutch packs, they are capable of providing the Aisin AF33-5 with six different gear ratios through the gear sets.

Low Clutch and Second Clutch Sprags

The Aisin AF33-5 incorporates two sprags as part of its apply components. One sprag is used for low, and the other is used for second (Figure 7-4).

1. Front Internal Gear and Low Clutch Sprag

The front internal gear and low clutch sprag assembly is located between the front internal gear outer race and the low clutch sprag inner race. The low clutch sprag is a type of one-way mechanical clutch that holds the front internal gear stationary during acceleration in first gear, in all ranges.

2. Second Clutch Sprag

The second clutch sprag assembly is located between the second clutch sprag outer race assembly and the second coast clutch hub inner race. When the second clutch sprag is holding, it prevents the second coast clutch hub and the front sun gear from rotating in the direction opposite of engine rotation. The clutch hub is holding when the transaxle is in second, third and fourth gears.

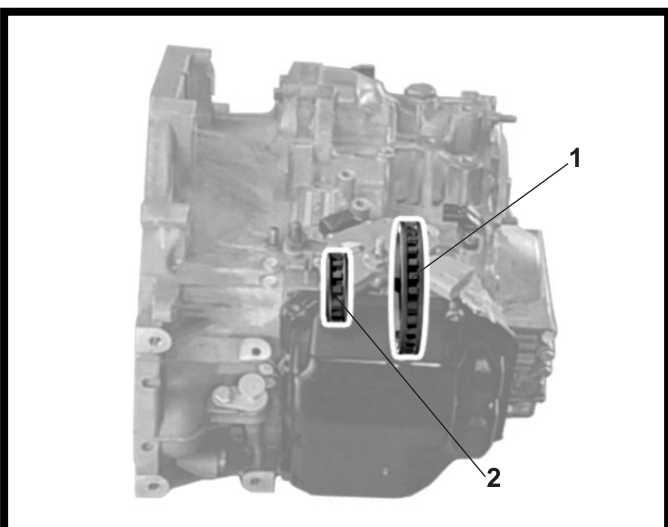

Figure 7-4, The Aisin AF33-5 Uses Two Mechanical Sprags

8. Service Items: On-Vehicle

On-Vehicle Service Items

The Aisin AF33-5 has a number of service items that are considered on-vehicle transaxle repair. They include:

- Wiring Harness
- Park/Neutral Position Switch
- Input Speed Sensor (ISS)
- Output Speed Sensor (OSS)
- Oil Level Gauge
- Valve Body Assembly
- Shift Solenoids

These items can be replaced without removing the transaxle from the vehicle.



Figure 8-1, Many Items Can Be Repaired/ Replaced With the Transaxle in the Vehicle

On-Vehicle Procedures

The following list of procedures can be completed without removing the transaxle from the vehicle:

- Fluid Level Check
- Line Pressure Check
- Park/Neutral Position Switch Adjustment (Figure 8-2)



Figure 8-2, Park/Neutral Position Switch Adjustment

8. Service Items: On-Vehicle

Fluid Level Check Procedure



Figure 8-3, Checking the Fluid Level

Typically, the fluid level should not need to be checked, unless there is a fluid leak, or a service has been completed that required fluid removal. However, if you do need to check the fluid level in the Aisin AF33-5 it is relatively simple task, once you know where to look. This transaxle has no dipstick tube, but it does have a dipstick. It is located on the inboard side of the transaxle, and is attached to the case with a retaining bolt. This retaining bolt needs to be removed in order to extract the dipstick, and check the fluid level (Figure 8-3).

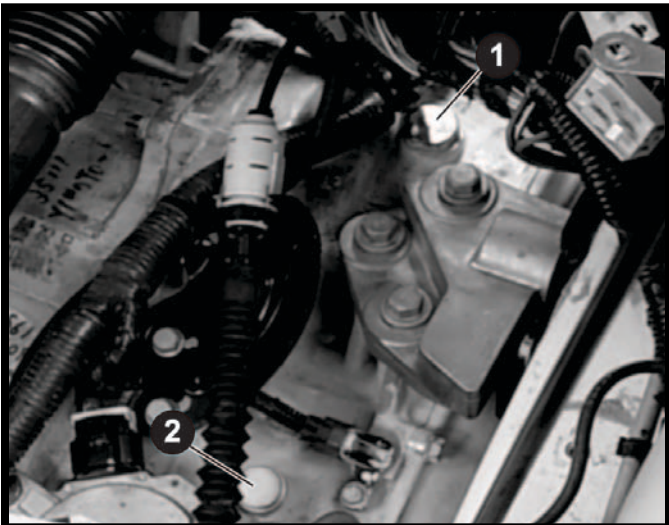

Figure 8-4, Fluid Fill Plug and the Third Gear Band Anchor Bolt

If you ever need to fill the transaxle, make sure to remove the fluid fill plug, which is near the park/neutral position switch. **DO NOT** remove the third gear band anchor bolt (Figure 8-4).

1. Third Gear Band (Five Sided)
2. Fluid Fill Plug (Hex Head)

— SPECIAL NOTE —

Removal of the third gear band anchor bolt will result in a loss of third gear. This cannot be corrected by simply replacing the bolt. The transaxle must be removed from the vehicle and disassembled for repair.

Third Gear Band Anchor Bolt

— CAUTION —

DO NOT, under any circumstances, remove the third gear band anchor bolt while the transaxle is installed in the vehicle.

Because of its close proximity to the fluid fill plug, you must understand the danger of accidentally removing the third gear band anchor bolt (Figure 8-5).

The third gear band anchor bolt is distinguishable by its five sided, pentagon shape and to remove it requires the use of special tool DT 47599.

Removal of the third gear band anchor bolt will release the third gear band that wraps around the four-five clutch drum (Figure 8-6). This will result in a loss of third gear and will require transaxle removal and disassembly for repair.

Simply replacing the bolt after removal will not correct the un-seated band.

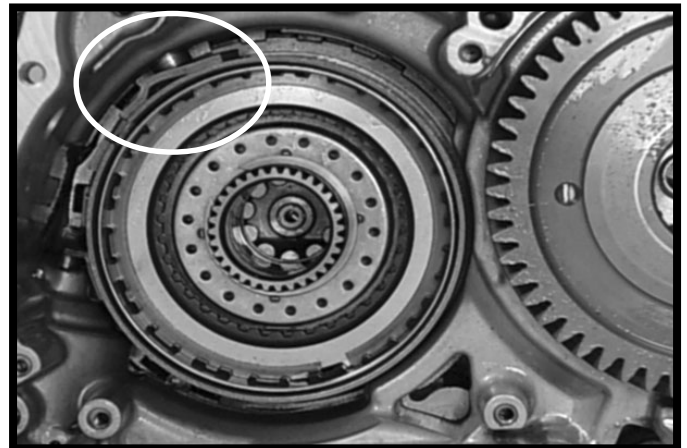

Figure 8-5, The Third Gear Band Anchor Bolt Correctly Seated

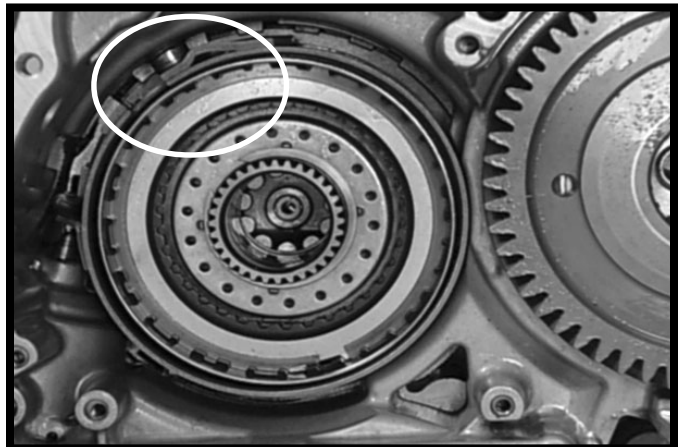

Figure 8-6, The Third Gear Band Anchor Bolt Un-Seated

8. Service Items: On-Vehicle

Line Pressure Check

Line pressure may be checked on the Aisin AF33-5 using tool J 21867 and adapter J 21867-50 installed in the transaxle fluid pressure test hole.

The line pressure is checked in two gear ranges. Reverse and Drive.

The pressure check must be completed in both of these ranges to ensure that the pressure requirements are met in different gear ranges.



Figure 8-7, Check the Line Pressure in Reverse and Drive

Park/Neutral Position Switch

The Park/Neutral position switch (Figure 8-8) is a sliding contact design, and is attached to the manual shift detent lever on the outside of the transaxle case.

The function of a Park/Neutral position switch and a manual lever position sensor are combined in this single assembly.

Four signals are produced and sent to the TCM. These four signals indicate which gear the driver has selected.

The four Park/Neutral position switch signals are:

- **Mode A**
- **Mode B**
- **Mode C**
- **Mode PA**

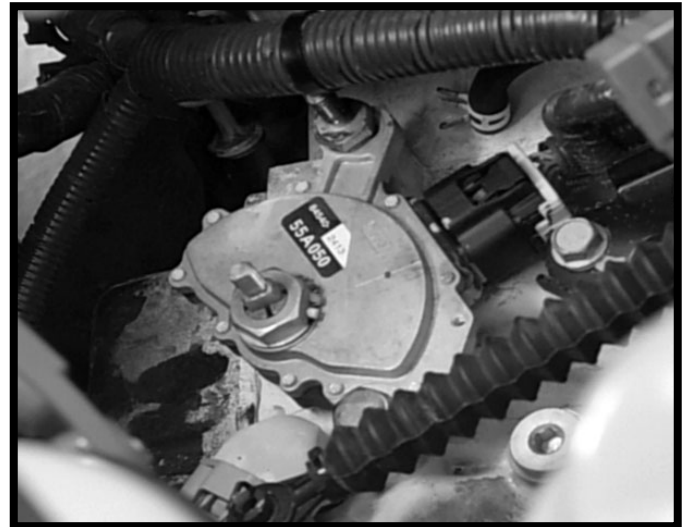

Figure 8-8, The Park/Neutral Position Switch

Figure 8-9 shows the switch state of the manual position lever.

All of these input sensors can be monitored using the Tech 2, but remember that you need a CANdi module because the TCM is on GMLAN.

RANGE INDICATOR	CIRCUIT				
	IG	A	B	C	D
PARK	1	1	0	0	1
REVERSE	1	1	1	0	0
NEUTRAL1	0	1	0	1	
DRIVE	1	0	1	1	0
LOW 4	1	1	1	1	1
LOW 2	1	1	0	1	0

1=Closed (resistance < 10 ohms) 0=Open (resistance > 100k ohms)

Figure 8-9, Transaxle Range Switch Logic Chart

8. Service Items: On-Vehicle



Figure 8-10, Tool J 45404

Park/Neutral Position Switch Adjustment

If the vehicle is capable of starting in a position other than Park or Neutral, this indicates that the Park/Neutral position switch requires an adjustment.

To begin, the battery box, the battery and the battery tray bracket must first be removed from the vehicle in order to access the switch.

Refer to battery replacement and battery box replacement in SI for detailed information about the removal and reinstallation procedure for these components.

The adjustment procedure is as follows:

- Shift the transaxle into the Neutral position.
- Using the Fascia Retainer Remover, tool J 36346, remove the control cable assembly from the Park/Neutral position switch lever.
- Loosen the transaxle range switch bolts and install the Transaxle Range Shift Alignment tool, special tool J 45404 (Figure 8-10) and align the pointer to the neutral basic line.
- Remove the alignment tool and tighten the Park/Neutral position switch bolts to 25 Nm, or 18 lb ft.
- Install the control cable assembly to the Park/Neutral position switch lever.
- Reinstall the battery tray bracket, the battery box and the battery.
- After the switch has been adjusted, verify that the engine will only start in Park or Neutral.
- If the engine starts in any other position, readjust the switch as necessary.

9. Service Items: Bench

Bench Service Items

The Aisin AF33-5 also has a number of service items that are considered bench repair.

- Filter Replacement
- Rotational Torque Measurement
- Front Differential Bearing Replacement
- Front Differential Side Gear Shim Replacement
- Selective Thrust Washer Replacement
- Clutch Pack Replacement
- Planetary Gear Replacement

These items must be serviced with the transaxle removed from the vehicle (Figure 9-2).



Figure 9-1, Internal Components of the Aisin AF33-5

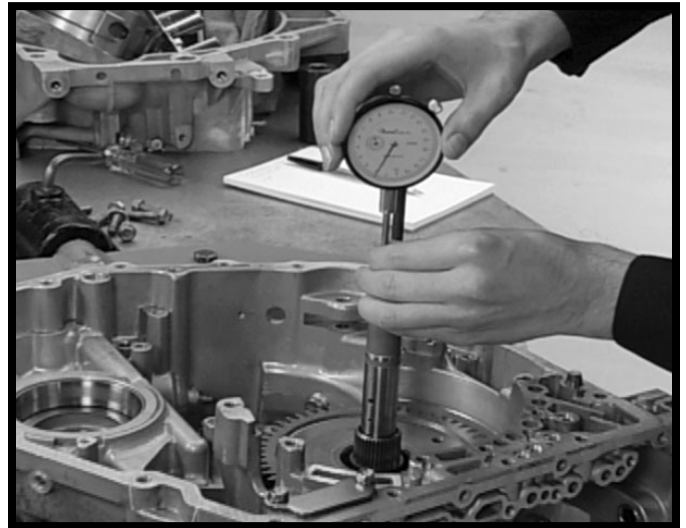

Figure 9-2, Transaxle Removed From the Vehicle

Filter Replacement

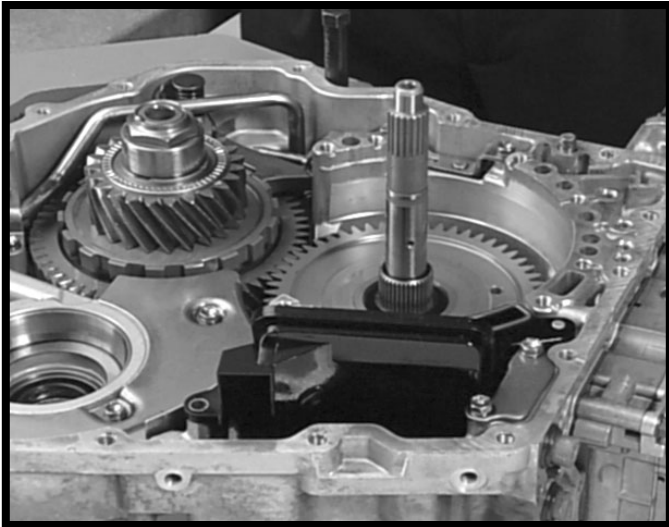

Figure 9-3, The Fluid Filter in the Aisin AF33-5

Filter replacement is NOT a routine maintenance item during normal use. The Aisin AF33-5 is considered a filled-for-life transaxle. However, if filter replacement is required, the transaxle must be removed from the vehicle. This is an outline only. Refer to SI for the complete service procedure.

- Rotate the transaxle assembly so that the fluid pump is facing up
- Remove the 8 fluid pump bolts, and use tool J 45053 to remove the fluid pump assembly from the transaxle case
(Be sure not to damage the stator shaft bushing during this step)
- Remove the second coast clutch hub/outer race and second coast clutch hub and washer
- Remove the 17 torque converter housing cover bolts

— SPECIAL NOTE —

Make sure that you are extremely careful not to interchange the 30mm torque converter housing bolts with the 28mm fluid pump bolts. If you use the longer 30mm bolts in the fluid pump, you will cause internal damage in the transaxle.



Figure 9-4, Aisin AF33-5 Fluid Filter

- Remove the torque converter housing (If needed, a soft-faced hammer can be used to assist in the removal of the torque converter housing)
- Remove the front differential assembly and the case fluid passage gasket
- Remove the fluid filter retaining fastener
- Remove and replace the fluid filter
- After checking front differential bearing pre-load, the transaxle may be reassembled

During transaxle reassembly, it is necessary to check the front differential bearing pre-load.

Front Differential Bearing Pre-Load

Front differential bearing pre-load is inspected by measuring torque needed to rotate the differential carrier (Figure 9-5).

- Start with the torque converter housing facing up
- Install the front differential into the empty transaxle case
- Install the torque converter housing to the transaxle case using the 30mm bolts and torque them in sequence
- Insert tool DT 47687 into the axle shaft opening of the differential over the exposed differential splines
- Rotate the tool until it engages with the differential pinion shaft
- Use a beam-type torque wrench to measure the rotational torque required to slowly rotate the front differential assembly
- Record the readings
- Remove the tool from the front differential assembly
- Shim as necessary
- Continue transaxle re-assembly

This is an outline only. Refer to SI for complete service procedure.

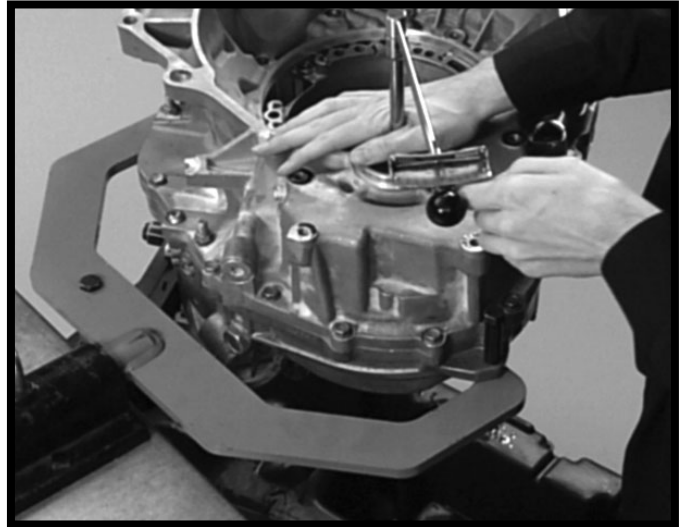

Figure 9-5, Checking Front Differential Bearing Pre-Load

9. Service Items: Bench

Bearing Torque Specification

When checking the front differential rotational torque, the torque rating should be between 6-11 lb in, or 0.69-1.18 Nm.

If the measurement is within the specifications, pre-load adjustment is not necessary. If the measurement is **not** within the listed specifications, then the front differential bearing race shim **must** be changed to the proper thickness. SI will show you the sizes available for this application.

— SPECIAL NOTE —

A thicker shim increases rotating torque.
A thinner shim decreases rotating torque.

Measure Forward and Direct Clutch End Play

If the transaxle has been disassembled, it is necessary to measure the forward and direct clutch end play before reassembly is complete.

In order to properly measure end play:

- Reassemble the transaxle to the point where the forward and direct clutch assembly is installed in the case
- Install the transaxle case cover
- Rotate the transaxle case so that the input shaft is facing up
- Mount and zero the dial indicator



Figure 9-6, Replacing the Selective Thrust Washer

— SPECIAL NOTE —

Before every measurement, ensure that the contact tip of the dial indicator is tight.

- Carefully pull straight up on the input shaft until it stops
- Record the measurement shown on the dial indicator

Specification: Forward and direct clutch end play measures between .007 - .022 in. (0.188 - 0.570mm). End play is adjusted using a selective thrust washer. Refer to SI for further details.

9. Service Items: Bench

Gaskets

One final note about the Aisin AF33-5, there are no gaskets to seal the control valve body cover to the case or to secure the case to the torque converter housing.

In order to properly seal these surfaces, you will need to use an approved GM sealant (Figure 9-7).

The sealant is specified as GM P/N 89020326, or equivalent



Figure 9-7, Use Only GM Approved Sealant

GENERAL MOTORS TRAINING MATERIALS

- Authentic GM Training Materials for Classroom Courses, Videos, Certified-Plus Training (CPT), Computer-Based Training (CBT), Interactive Distance Learning (IDL), and GM Service Know-How
- Hydra-matic Training Publications
- Training Simulators

These publications & videos offer thousands of facts on service procedures and how systems operate on GM cars and trucks.

Includes the same materials used in General Motors Training Centers for GM Dealer Technician Training.

***Send today for your FREE
GM training materials catalog***

General Motors Training Materials
MSX International
1426 Pacific Drive ● Auburn Hills, MI 48326
1-800-393-4831



WE SUPPORT
VOLUNTARY TECHNICIAN
CERTIFICATION
THROUGH

