

AKA News

Knitting



The Journal of the American Kitefliers Association

Volume 8 Number 5 1986

1986 Newport Convention
SPECIAL EDITION



Shirone Giant To Fly
At AKA Newport Convention

Member Merchants

The following merchants have agreed to allow a 10% discount to AKA members.

High As A Kite
34 Princess Street
Sausalito, CA 94965
(415) 332-8944

Kite & Gift, Inc.
333 Jefferson Street
San Francisco, CA 94133
(415) 885-5785

Hyperkites
1821 Fifth Avenue
San Diego, CA 92101
(619) 231-4977

Kite Dreams
751 W. Washington Blvd.
Los Angeles, CA 90014
(213) 614-8911

Kite Makers of San Francisco
Pier 39, Space A-13
San Francisco, CA 94133
(415) 641-1226

Fighting Kite Co.
3116 Arlotte Avenue
Long Beach, CA 90808
(213) 596-9360

Seaport Kite Shop
867 W. Harbor Drive
San Diego, CA 92101
(619) 232-2268

The Ultimate High
419 Shoreline Village Drive
Long Beach, CA 90802
(213) 436-3180

Colors of the Wind
2900 Main Street
Santa Monica, CA 90405
(213) 399-8044

Fabric Design
2101 Bryant Street
San Francisco, CA 94110
(415) 387-3306

The Crossing
P.O. Box 248
Duncan Mills, CA 95430
(707) 865-2829

Windborne Kites
585 Cannery Row
Monterey, CA 93940
(408) 373-7422

Victoria Kite Store
102-560 Johnson Street
Victoria, British Columbia
Canada 7BW 3C6
(604) 381-5377

Touch the Sky, Inc.
836 Yonge Street
Toronto, Ontario
Canada, M4W 2H1
(416) 964-0434

Touch the Sky—Harbourside
207 Queens Quay West
Toronto, Ontario
Canada M5J 1A7
(416) 362-5983

The Kite Store
1415 Larimer Square
Denver, CO 80202
(303) 623-2353

The Kite Site
3101 M Street, N.W.
Washington, DC 20007
(202) 965-4230

The Kite Shop
49 Rehoboth Avenue
Rehoboth Beach, DE 19971
(302) 227-1616

Cloud 9 Kites
1122 East Atlantic Avenue
Delray Beach, FL 33444
(306) 272-5224

Toys Ahoy
28 Periwinkle Place
Sanibel Island, FL 33957
(813) 472-4800

Harper's Bizarre
99 E. Palmetto Park Road
Boca Raton, FL 33432
(305) 392-9297

Harper's Bizarre
328 North Federal Highway
Boca Raton, FL 33432

Harper's Bizarre
Seafair Mall
101-14 North Beach Road
Dania, FL 33004
(305) 272-5224

Key West Kite Company
409 Greene Street
Key West, FL 33040
(305) 296-2535

High Performance Kites
1019 University Avenue
Honolulu, HI 96826
(808) 942-8799

Kite Fantasy
2863 Kalakaua Avenue
Honolulu, HI 96815
(808) 732-KITE

Stanton Hobby Shop, Inc.
4734 North Milwaukee Avenue
Chicago, IL 60630
(312) 283-6449

Video Hotline, Inc.
858 Green Bay Road
Winnetka, IL 60093
(312) 441-8070

Outermost Kites
P.O. Box 1032
240 Commercial St.
Provincetown, MA 02657
(617) 487-3766

Outermost Kites
North Market Building
Faneuil Hall Market Place
Boston, MA 02109

Outermost Kites
570 Main St.
Hyannis, MA 02601
(617) 775-7263

Outermost Kites
393 Thames St.
Newport, RI 02840
(401) 849-6203

Hobbies, Games & Software
Westboro Shopping Center
Westboro, MA 01581
(617) 366-2030

Whippoorwill Crafts
126 South Market Building
Faneuil Hall Market Place
Boston, MA 02109

Kites Aweigh
6 Fleet Street
Annapolis, MD 21401
(301) 268-6065

The Kite Loft
5 N 2nd Street
Ocean City, MD 21842
(301) 289-7855

The Kite Loft
Harborplace
Light Street Pavilion
Baltimore, MD 21201
(301) 528-0888

Windy's Kite Shop
37½ Cottage Street
Bar Harbor, ME 04609
(207) 288-5337

Where the Wind Blows
500 Pleasure Creek Drive
Blaine, MI 55434
(612) 786-7607

Unique Place/World of Kites
525 S. Washington at Sixth
Royal Oak, MI 48067
(313) 398-5900

Soar-n-Dipity
1102 Flushing Road
Flint, MI 48504
(313) 234-8320

Kite Kraft
245 S. Main
Frankenmuth, MI 48634
(517) 781-3029

Toys Ahoy
249 Culver Street
Saugatuck, MI 49453
(616) 857-2621

Sky Line Kite Shop
Tower 200
Detroit, MI 48243
(313) 249-4504

Mackinaw Kite Company
Chinook Pier
Grand Haven, MI 49417
(616) 846-7501

Mackinaw Kite Company
105 Huron Street
Mackinaw City, MI 49701
(616) 436-8051

Kitty Hawk Kites
Rt. 1, Box 226
Kill Devil Hills, NC 27948
(919) 441-4629

Something in the Air
353 Ocean Boulevard
Hampton Beach, NH 03842

Gone With the Wind
Old Cobblestone Village
Vernon, NJ 07462
(201) 827-8754

Gone With the Wind
Americana Resort
McAfee, NJ 07428
(201) 827-3555

Colors of the Wind
345 W. Manhattan
Santa Fe, NM 87501
(505) 982-8235

Go Fly A Kite, Inc.
153 East 53rd Street
New York, NY 10022
(212) 308-1666

Outta Sight Kites
12-77 Country Village
Kingston, NY 12401
(914) 331-9085

Go Fly A Kite
1201 Lexington Avenue
New York, NY 10028
(212) 247-4440

The Kite Kompany
33 West Orange
Chagrin Falls, OH 44022
(216) 247-4223

Once Upon A Time
153 The Arcade
401 Euclid Avenue
Cleveland, OH 44114
(216) 696-TOYS

Flights of Fancy
22 S. High Street
Dublin, OH 43017
(614) 764-8697

Wind Play
232 S.W. Ankeny Street
Portland, OR 97204
(503) 223-1760

Kites & Other Delights
28667 Spencer Creek Road
Eugene, OR 97405
(503) 484-0104

Kites & Other Delights
Fifth Street Market
Eugene, OR 97401
(503) 344-KITE

The Kite Shop
P.O. Box 517
Rockaway, OR 97136
(503) 355-8088

Klassy Kites
King of Prussia Plaza
King of Prussia, PA 19406
(215) 337-2199

The Rainbow Store
952 Hamilton Mall
Allentown, PA 18101
(215) 770-1080

The Rainbow Store
Market Place
Bethlehem, PA 18018
(215) 865-2572

The Meadow Mouse Shop
520 N. Pennsylvania Avenue
Morrisville, PA 19067
(215) 736-8253

Airborne Kites
Bannister's Wharf
Newport, RI 02840
(401) 849-5688

Klig's Kites
Myrtle Beach Pavilion
Myrtle Beach, SC 29577
(803) 626-9250

Klig's Kites
North Kings Highway
Myrtle Beach, SC 29577
(803) 449-2856

Houston Camera Exchange
5801A Bissonnet
Bellaire, TX 77401
(713) 557-9267

Krazy Kites
Virginia Beach Fishing Pier
Virginia Beach, VA 23451
(804) 422-5483

Great Winds Kite Shop
402 Occidental Avenue, So.
Seattle, WA 98104
(206) 624-6886

Suspended Elevations
2116 N. Pacific
Seattle, WA 98103
(206) 633-4780

Fish Creek Kite Company
3853 Highway 42
P.O. Box 331
Fish Creek, WI 54212
(414) 868-3769

Four Winds Kite Company
N70 W6340 Bridge Road
Cedarburg, WI 53012
(414) 375-1226

Pages Booktraders
801 South Irwin Avenue
Green Bay, WI 53001
(414) 437-9566

**Drachen & Drachensachen
Kite Store**
Eisenacher Strasse 81
1000 Berlin 62 Germany
030/784 77 69 - 795 47 00

1986 Officers and Executive Committee

President
Margo Brown
6636 Kirkley Avenue
McLean, VA 22101
(703) 893-3886

First Vice President
Robert Price
3839 Dustin Road
Burtonsville, MD 20866
(301) 421-9620

Second Vice President
Fran Gramkowski
High Fly Kite Company
33 Evergreen Lane
Haddonfield, NJ 08033
(609) 429-6260

Third Vice President
Michael Keating
2283 Bristol Road
Columbus, OH 43221
(614) 451-4870

Corresponding Secretary
Nat Kobitz
6708 Chippewa Drive
Baltimore, MD 21209
(301) 486-8253

Recording Secretary
Jewell Price
3839 Dustin Road
Burtonsville, MD 20866
(301) 421-9620

Treasurer
Jon Burkhardt
10113 Lloyd Road
Potomac, MD 20850
(301) 424-6976

Board of Past Presidents

W.D. (Red) Braswell
10000 Lomond Drive
Manassas, VA 22110
(703) 361-2671

Bevan Brown
6636 Kirkley Avenue
McLean, VA 22101
(703) 893-3886

Founder

Robert Ingraham
315 No. Bayard Street
Silver City, NM 88061
(505) 538-9083

John F. (Jack) Van Gilder
1925 Walnut, S.W.
Seattle, WA 98116
(206) 938-0550

Miller S. Makey, Sr.
2557 Clark Drive
Grove City, OH 43123
(614) 871-0727

Sustaining Members

Red Braswell, Wood Ellis
George Moran, Hod Taylor

Sponsor Members

Red Braswell

Regional Directors

REGION 1: New England
CT, NH, MA, ME, RI, VT
Carl Poehler
9 Vine Street
Melrose, MA 02176
(617) 662-6999

REGION 2: New York State
Jerry Gorsuch
380 Grimsby Street
Staten Island, NY 10306
(718) 351-7461

REGION 3: Penn-Jersey
New Jersey, Pennsylvania
Michael Carroll
P.O. Box 215
Plainsboro, NJ 08536
(609) 799-6398

REGION 4: Mid-Atlantic
DC, DE, MD, VA, WV
Pete Ianuzzi
1908 Old Frederick Road
Baltimore, MD 21228
(301) 744-4754

REGION 5: South
AL, FL, GA, LA, MS, NC, SC, TN
Charlie Henderson
3044 Anthony Drive
Decatur, GA 30033
(404) 292-0649

REGION 6: Northeast Central
IN, KY, MI, OH
Fred Bell
315 S. Kellner
Columbus, OH 43209
(614) 231-1559

REGION 7: Northwest Central
IA, IL, MN, WI
Al Hargus, III
4705 W. Byron
Chicago, IL 60641
(312) 545-9572

REGION 8: Mountain
AZ, CO, ID, MT, ND, NE,
NM, NV, SD, UT, WY
Brian Volkman
The Kite Store
1415 Larimer Square
Denver, CO 80202
(303) 477-9549

REGION 9: Southwest
AR, KS, MO, OK, TX
Michael G. Freeman
P.O. Box 12039
Wichita, KS 67277
(316) 721-3848

REGION 10: Pacific NW
AK, HI, OR, WA, BC
Doug Hagaman
4413 123rd Avenue, S.E.
Bellevue, WA 98006
(206) 746-7378

REGION 11: N. California
Monterey County and North
Bob McCort
801 Carson Avenue
Manteca, CA 95336
(209) 823-3212

REGION 12: S. California
South of Monterey County
Tony Cyphert
3734 Madison
Unit 10
San Diego, CA 92116
(619) 280-3075

REGION 13: International
Adrian Conn
344 Dieppe Street
Windsor, Ontario
Canada N8S 3V2
(519) 948-8819

DEPARTMENTS

2 MEMBER MERCHANTS

4 PRESIDENT'S CORNER

By Margo Brown

5 OBSERVATIONS

By John F. VanGilder

11 KITE PLANS MADE EASY

The Fighter Kite
By Wayne Hosking

13 AKA NEWS

Executive Committee Minutes
Submitted by Jewell Price



FEATURES

6 THE 5TH ANNUAL WASHINGTON STATE INTERNATIONAL KITE FESTIVAL

At Long Beach, Washington --
28 miles of uninterrupted beautiful
beach and winds from the sea
Courtesy of Kay Buesing

8 THE AMERICAN KITEFLIERS' 1986 CONVENTION AT NEWPORT, R.I.

9 1986 AKA CONVENTION SCHEDULE

9 MUSIC BALLET COMPETITION FOR MANEUVERABLE KITES

By Olan Turner

10 NATIONAL FESTIVAL EVENTS

By Bevan Brown, Fran Gramkowski,
Robert Loera, Charlie Sotich,
and Olan Turner

16 AKA T-SHIRTS ON SALE

How to get your limited
edition AKA T-shirt.

Cover Photo: The Giant Shirone Kite was flown at the Black Ships Festival by the Japanese Delegation and 15 friends. It measures 5 meters by 7 meters tall and is made of washi paper and bamboo construction. It will fly again at the 1986 AKA Convention at Newport. **Cover Photo Credit:** Ms. Dale Alley, of Warwick, R.I.

Editorial Staff

Fred Bell
Bill Biggie
Red Braswell
Bevan Brown

Margo Brown
Jon Burkhardt
Tom Casselman
Dr. Paul E. Garber

Pete Ianuzzi
Robert Ingraham
Hazel Ingraham
Nancy Keating

Arthur Kurle
Charlie Sotich
Jack Van Gilder
Debra Lashbrook, Editor

Kiting is published in odd numbered months by the American Kitefliers Association, 6636 Kirkley Avenue, McLean, VA 22101.

Distributed free of charge to AKA members.

President's Corner

LOOKING AHEAD!

October seems to be a time of renewal for kitefliers. Those of us who fly kites know that October's steady winds continually beckon us away from our appointed tasks. When a large part of the world is preparing for winter, kitefliers create another spring for themselves on the fields and beaches of the world.

October is also a time for renewing friendships at our national convention. Your board and convention committee have been working at top speed to develop items for the convention schedule contained in this special Newport Convention edition. In the convention information section is an overview and schedule of daily activities. Barring that old nemesis — weather, all plans should go great! We are also circulating a "Fast Facts" sheet (you may have already seen it) and I would like to thank Newport and other member clubs who printed this fact sheet in their newsletters and helped spread the word.

Since the fast facts sheet was put together, Rick Kinnaird has finalized plans for an Auction Committee meeting on Thursday, October 2 at 5 p.m. Rick would also like to have the word circulated for volunteers especially to fill the following positions at the auction — an auction marshal, major domo, head cashier, chief recorder, treasurer and an auction reporter. Further explanation about the duties of the volunteers can be had from Rick at (301)229-1708. You may wonder why you are getting this info from me in this letter. Well, Rick is busy preparing to become a father in October. We will miss Eileen at the convention this year. She says she is convinced that the timing of this blessed event is a "Rainbow Warriors" revenge, but most of us Mama-Sans are thinking Eileen will give us a new Mama-San recruit for our team.

For AKA Members interested in the Educational Workshop Kite Packet, please take time to give us your thoughts at the convention display. Take pen in hand and comment on the material on display by the registration desk as you pick up your items for the convention. After final comments are made on the packet, this workshop item will go into final



printing and be available as one of AKA's public service offerings.

A Membership Directory is another one of the items that will be available at the convention for purchase by AKA members. This Membership Directory has been requested by numerous AKA members. If you do not wish to be listed in this AKA Membership Directory, which is restricted to private use only, contact us by October 1st or your name will appear in the Directory. Our first Directory was available after the Houston Convention and this one will be set up in a similar manner. This booklet is the complete AKA membership, separate from the convention attendance list.

We have been working extremely hard to improve the business management aspects of AKA. We have just completed a close review of our three most critical support functions and taken action to ensure that essential services are provided in each. These are (1) preparation and production of your AKA Journal, (2) maintaining membership rolls, and (3) maintaining financial records.

At present, we have hired Debra Lashbrook as Editor of your Journal, and she is assisted and guided by your editorial staff. Bob Price is maintaining the membership rolls and depositing dues, and we have a consultant accountant who is working with Jon Burkhardt, our new AKA Treasurer to set up an appropriate record keeping system. Hamilton Wells, previous Treasurer on this AKA Board, will continue to act as a consultant for us and will be working with Jon. (A nice piece of news about Ham's eye damage is that a lazer treatment was used and Ham's vision is healing. Ham is a great guy and I wish you all could meet him.)

These initial steps have taken care of our immediate needs, but we have further to go. With your support we can accomplish anything. We are committed to continuing our efforts until we can provide for long term stability and consistent quality of member services.

One world, one sky, let's fly!

Observations

RAGING CONTROVERSY ON RUDDERS

By John F. VanGilder

In response to Bob Ingraham's letter in *Kiting*, May, 1986, "Are They Bridles or Keels?", I must say that it's about time SOMEBODY rose to the bait and commented. Where are the rest of you lily-livers?

He got it right about delta "keels" being nothing but "solid bridles". He's right-on when he says the triangular shape of the keel supports the centerline spar. He's approximately correct when he states the Japanese kitemakers have used multi-string bridles for "...maybe 25,000 years." That ol' shellback was THERE.

But when Bob teed off on my and Al Hartig's use of keels as rudders, he could not have picked on a point I am more sure of. I have been correcting yaw (flying off to one side or the other) for literally YEARS by the simple device of adding a rudder to the back, lower, aft end of a delta keel. Bob probably doesn't have as much experience with unbalanced deltas as I do. Maybe when I reach age 89 I'll be the craftsman he is.

I never go flying without my flightbag containing reels of assorted-strength line, etc., and TAPE. To correct delta yaw, slit the last few inches of the keel and stiffen it with tape:

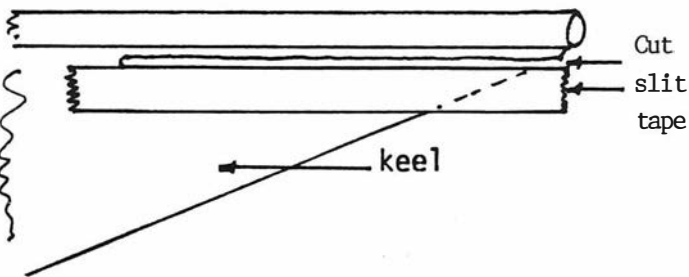

Lay kite flat, upside down, and tape end of keel, which has become an instant rudder, off to one side — but just a very little bit:

Bottom View:

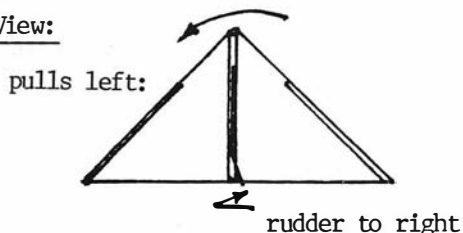

Aft End View:
taped rudder

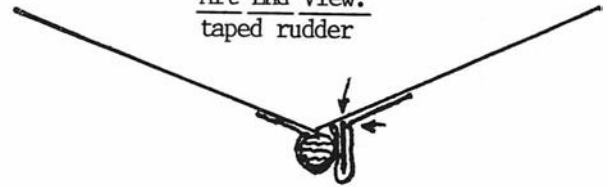

Tape rudder to wing and center spar — tape off-center very little. It's surprising how little it takes to control a large kite.

On some of my cloth kites, I've tried to get fancy with battens to stiffen the rudder. But I found to my sorrow that you need strong 1/16th-inch fiberglass. Bamboo curtain shade sticks break easily when the kite is rolled up.

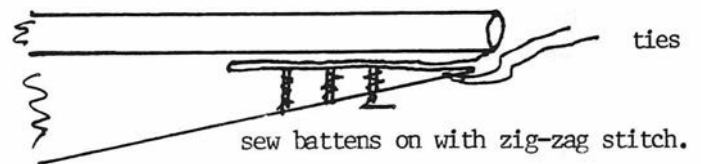

I must admit that Bob and I have already exchanged missiles on this subject immediately after publication of *KITING*. And for some reason he took umbrage at the fact that I addressed him as "Living Legend," something about "sounding like old and musty things." I can't understand it.

He told me in uncertain terms that "...you are of course all wrong in your cockeyed theories about kite rudders but poor old Alexander Graham Bell thought the tetrahedron was the ideal airfoil but look how well he made out after he got into the cracker business." I had warned him that I knew enough to duck after I flang.

He went on to "...appreciate your undying interest in my mental welfare. You are driving me crazy with your screwball aerodynamic theories..." When I noted that I hoped he (especially he) and Hazel were mellowing with age, he did soften a bit: "My sympathies to Vi as usual. The poor girl suffers, I know. And my best, because I know that beneath your crude exterior there beats a heart of gold."

All I said was!!!

The Washington State Kite Festival

Information & photographs
courtesy of Kay Buesing

The 5th Annual WSIKF ran from August 18th through the 24th on the sands at Long Beach. It echoed the international air of last year's festival. Kite experts from England, Japan and the United States were featured at the seven-day event. Katsutaka Murooka, from Japan, flew his giant rokkakus and kytoon kites, which are half balloon and half kite. Attached to his kites were still and video cameras which took aerial photographs of the festival.

Martin Lester demonstrated his three-dimensional inflatable kites from England — all real crowd pleasers — especially his ghostly sharks!

Margo Brown, AKA President, helped judge single line competitive events and succumbed to temptation and added to the Brown collection a Martin Lester American space shuttle, which she says will fly at next spring's Smithsonian Air & Space Museum's Kite Festival as a demonstration item for the crowd.

Robert Loera, a champion stunt kite flier from Hawaii, attended the festival and organized the stunt kite competitions for the novice, amateur, and professional fliers. Robert also gave a fantastic demonstration of stunt kite maneuvers for the pleasure and delight of the spectators (estimated at 2500 at any one time).

Dusk on Friday found the Long Beach kitefliers lighting the sky with their kite night fly. Adding to the new "constellations" in the sky was a fireworks display sponsored by Mayor Fred Rutherford, of Long Beach.

The success of the fly was helped by the following kite committee members: Carole Knopski, Kay Buesing, Kent Butler, Tom Sisson, Roert Loera, Don and Lynn Lary, Doug Hagaman, Kathy Goodwind, Jim Kulbel, Kix Lowry and Virginia Leach.

STUNT COMPETITION WINNERS

Novice Stunt

1. David Wiltman
2. Eric Bourlet
3. Clay Davis

Intermediate Stunt

1. Martin Kramer
2. Jim Le Monte
3. Mike Brown

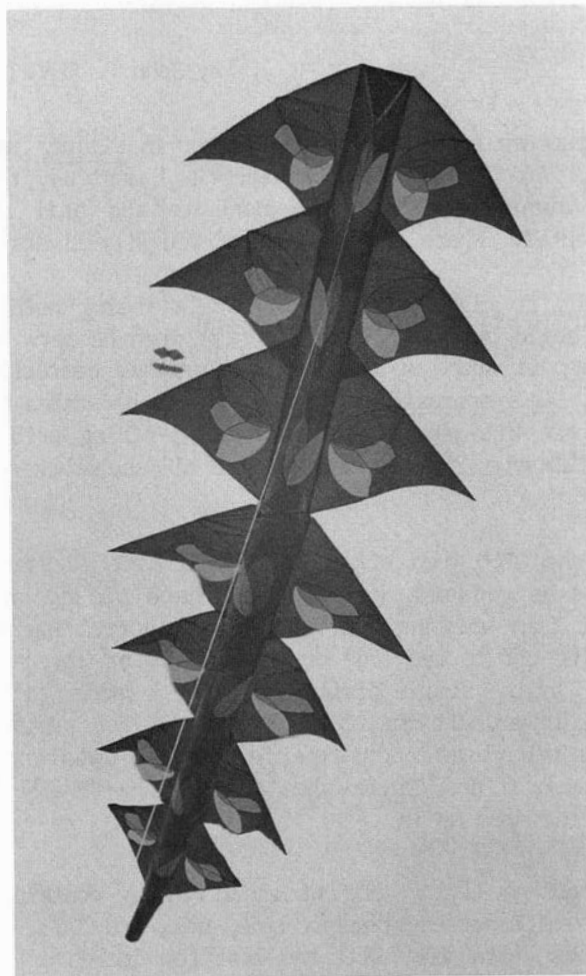

Stacked Deltas enhance the sky at Long Beach, Washington.

Professional Stunt

- 1st Ken Fredericks
- 2nd Randy Tom
- 3rd Eric Streede

Kite Team Competition

(Steve Edeiken Memorial Award)

- 1st AOK Associated Oregon Kitefliers
- 2nd WKA Washington Kite Association
- 3rd CKG California Kite Group

HANDCRAFTED KITE WINNERS

Most Colorful

- 1st Bill Lester
- 2nd Bill Gobel
- 3rd Molly McConnell

Smallest

- 1st Mike Steel
- 2nd Tom Caldwell
- 3rd Leonard Hogg

HANDCRAFTED KITE WINNERS (continued)

Highest Angle

- 1st Larry Zilar
- 2nd Lynn Lary
- 3rd Molly McConnell

Reel Out

- 1st Don Lary
- 2nd Lynn Lary
- 3rd Rick Talbott

Most Unique

- 1st Larry Zilar
- 2nd Tom Caldwell
- 3rd Aime' Barsalou

Surprise Event

- 1st Mike Button
- 2nd Mark Satcliffe
- 3rd Dale Groff

INDIVIDUAL COMPETITION WINNERS

Reel Out

- 1st Dana Shaver
- 2nd Rick Talbott
- 3rd Bill Kirsch

Highest Angle

- 1st Betsy Parnell
- 2nd Bill Lester
- 3rd Larry Zilar

Longest Tail (spool)

- 1st Rod Yarger
- 2nd Heather Yarger
- 3rd Dana Shaver

Longest Tail (other)

- 1st Kay Henry
- 2nd Don Lary
- 3rd Larry Zilar

Oldest

- 1st Bob Hammah 4-18-08
- 2nd Julian Wolf 5-31-08
- 3rd Bob Conklin 9-20-09

Farthest from Home

- 1st Bob Conklin (Albany, N.Y.)
- 2nd Chad Curtis (Anchorage)
- 3rd Kay Henry (San Diego)

Best All Around

- 1st Larry Zilar
- 2nd Bill Lester (tied)
- 3rd Mike Button (tied)
- 4th Lynn Lary

Touch Me

- 1st Mike Button
- 2nd Lynn Lary
- 3rd Michael Boyce

Most Beautiful

- 1st Bill Goble
- 2nd Betsy Parnell
- 3rd Bill Lester

Longest Train

- 1st Scott Cowell
- 2nd Larry Zilar
- 3rd Bill Lester



CHILDREN'S DAY WINNERS

(1 to 9 Years)

47 entries

Most Beautiful

- 1st Aaron Beanguard
- 2nd Brett Talbot
- 3rd Brandon Talbot
- 4th Michael Lary

Highest Angle

- 1st Jason Tish
- 2nd Josh Woodward
- 3rd Brandon Lary
- 4th Hayley Yarger

Reel Out

- 1st Michael Lary
- 2nd Robin McCoy
- 3rd Tory Anderson
- 4th Cris Hamerus

Youngest Flyer

- 1st Karen Stanforth
(one year)
- 2nd Amanda Shaver
- 3rd Poppy Beldrow
- 4th Brandon Talbot

(10 to 16 Years)

69 entries

Most Beautiful

- 1st Adam Gunderson
- 2nd Rob Wernli
- 3rd Toby Church

Reel Out

- 1st Michael Boyce
- 2nd Rob Wernli
- 3rd Jason Alexander

Highest Angle

- 1st Adam Gunderson
- 2nd Randy Wirkkala
- 3rd Molly McConnell

Touch Me

- 1st Michael Boyce
- 2nd Sam Spute
- 3rd Randy Wirkkala
- 4th Michael Boyce

Crash Event

- 1st Paul Toutonghi
- 2nd Randy Wirkkala
- 3rd Michael Boyce



Martin Lester, England (left), Margo Brown, Virginia (center), and Katsutaka Murooka, Japan, compare notes prior to the dual line kite events. The dual line event attracted over 40 entries and had \$500 in cash awards. This dual line event introduced for the first time two new super kites - the Action Combo- a dart +8.2 and Hyper-kites' new Star Dart.

The American Kitefliers Convention

DROP ANCHOR IN NEWPORT, RHODE ISLAND!

October 2-5, 1986

Southern New England has held a key position in U.S. history since the Pilgrims landed at Plymouth Rock. The sea has remained a dominant factor in the region, dictating the weather and the livelihoods of the people. The America's Cup Yacht Race, run since the 1850's, began in Newport, our AKA Convention City.

Newport's best known features are its resort section of magnificent estates and its beaches. Between Easton and Bailey's Beaches is Cliff Walk, which winds on the bluffs for 3 miles, skirting many of these private estates. Cliff Walk is open to the public and lends itself to a banquet of pictures for camera buffs. The Newport Chamber of Commerce (10 America's Cup Avenue) offers taped walking tours of Cliff Walk and maps and brochures outlining a walking tour of historic Newport.

The town still retains the appearance of a colonial seaport. On the waterfront next to Thames Street is Bowen's Wharf, an area of restored 18th and 19th century shops and restaurants. The Old Colony House (1739) on Washington Square was the scene of milestones in America's move towards independence from Great Britain. The Declaration of Independence was read from the building's balcony and the Federal Constitution was ratified at the Old Colony House in 1790. Newport has had many famous residents. One was Matthew Perry, whose impressive naval career peaked with the opening of Japan in 1854. This accomplishment of Perry's is considered one of America's most successful naval diplomatic quests. Many naval sites are open to the Newport visitor. A reproduction of the ship **Providence**, the first authorized ship of the Continental Navy and the first command of John Paul Jones is at Fort Adams State Park, off Harrison Avenue. Narragansett Bay served as the principal anchorage for the Atlantic Fleet, and was protected by Fort Adams, one of the largest forts and which guarded the bay from 1799 to 1945. A mystery in Newport is the Old Stone Mill in Touro Park, between Bellevue Avenue and Mill Street. It is believed by historical researchers to have been built by Norsemen long before Columbus' voyage. Touro Synagogue, at 72 Touro Street is the oldest synagogue (1763) in America.

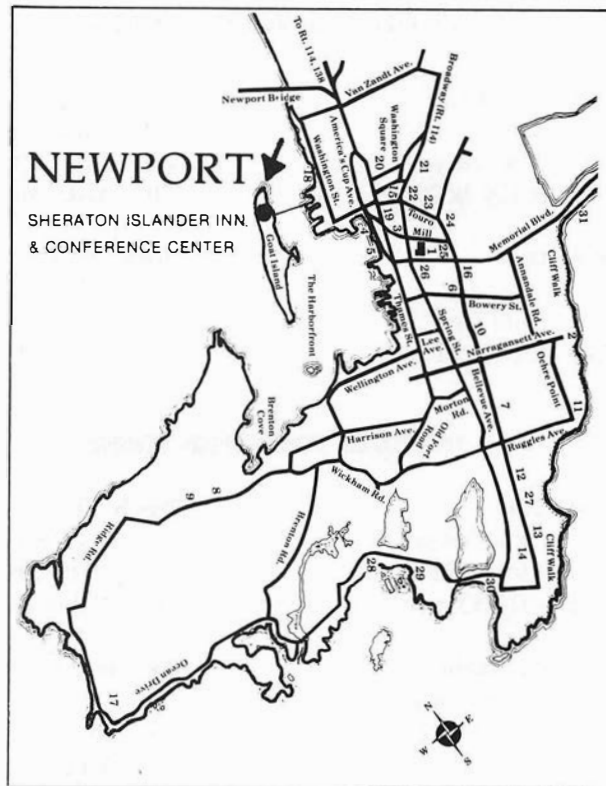

- | | |
|---------------------------------------|------------------------------|
| 1. Mill Street Inn | 17. Brenton Point State Park |
| 2. Cliff Walk-Forty Steps | 18. Hunter House |
| 3. Trinity Church | 19. Brick Market |
| 4. Bowen's Wharf | 20. White Horse Tavern |
| 5. Bannister's Wharf | 21. Hazard House |
| 6. Kingscote | 22. Touro Synagogue |
| 7. The Elms | 23. Newport Historical Soc. |
| 8. Fort Adams State Park | 24. Redwood Library |
| 9. Hammersmith Farm | 25. Old Stone Mill |
| 10. Chateau-Sur-Mer | 26. St. Mary's Church |
| 11. The Breakers | 27. Beechwood |
| 12. Rosecliff | 28. Hazard Beach |
| 13. Marble House | 29. Gooseberry Beach |
| 14. Belcourt Castle | 30. Bailey's Beach |
| 15. Old Colony House | 31. Newport Beach |
| 16. International Tennis Hall of Fame | |

MAP OF NEWPORT

Across the causeway, from Long Way (see map) is the convention hotel and as Newport is a walking town, most places are available to you for a less than 15 minutes walk. Transportation assistance has Tony Bisbano (401-683-1742) available to those with special needs.

NEWPORT, RHODE ISLAND

1986 AKA Convention Schedule

MUSICAL BALLET FOR MANEUVERABLE KITES

By Olan Turner

Thursday, October 2

All Activities in Convention Area & Adjacent Field

All Day	Registration
Noon to 4 P.M.	Workshops & casual flying
7 P.M. to 9 P.M.	Business Meeting
10 P.M. to 11 P.M.	Night fly, open & competitive

Friday, October 3

9 A.M. to 11:30 A.M.	Workshops (convention area)
11:30 A.M. to 1:00 P.M.	Kite flying demos (At Brenton Point State Park)
1 P.M. to 4:30 P.M.	AKA National Dual Line Competition, Challenge Events (Brenton Point)
6 P.M. to 7:30 P.M.	Buffet Dinner or Optional Clambake
7:30 P.M. to ?	AKA Annual Kite Auction

Saturday, October 4

10 A.M. to Noon	Challenges & Free Fly (Brenton Point)
11:30 A.M. to Noon	Rokakku Challenge (Brenton Point)
Noon to 1 P.M.	Kite Flying Demos, Registration & Picture-Taking for Member's Choice; Lunch on Field (Brenton Point)
1 P.M. to 4:30 P.M.	AKA National Comprehensive (Brenton Point)
5:30 P.M. to 6:30 P.M.	Cocktail Hour & Member's Choice Voting (Convention Banquet Area)
6:30 P.M. to 10 P.M.	Annual Banquet & Awards

Sunday, October 5

Morning	Brunch (at the hotel)
Afternoon	Tour of Newport Mansions and Harbor Cruise



This year's AKA Nationals will include competitions for both Individual and Team Ballet - Maneuvers flown and choreographed to music. Contestants will provide their own music on tapes. In both Individual and Team competitions the presentations will be limited to a minimum of 3 minutes and a maximum of 5 minutes.

Kites flown will be the option of the contestant and each participant may fly a single stunter or a multiple. In the Team Ballet a team must consist of two or more members.

Judging in both Individual and Team Ballet competitions will be based on the following elements:

- 1) Music Selection - appropriateness to the performance.
- 2) Choreography - how well the maneuvers fit the music.
- 3) Maneuvers - variety, smoothness and execution. For teams, execution will include coordination of maneuvers between team members.

Those members interested in competing in the Musical Ballet Competition should register as soon as possible upon arrival at the AKA Annual Meeting. Specific details on scoring and penalties and other pertinent factors will be reviewed at the Contestant Meeting prior to the competitions.

Usage of this logo by AKA members for personal purposes is permitted. All commercial usage will require written permission from Tom Casselman and the Convention Committee. He may be contacted at: 365 Riverside Street, Portsmouth, R.I., 02871 or (401)683-4880.



National Festival Events



By Bevan Brown, Fran Gramkowski,
Robert Loera, Charlie Sotich,
and Olan Turner

The Newport AKA National Kite Festival this year will be very similar in events and procedures to last year's at San Diego. The competitive events will include the AKA National Comprehensive, Dual Line Competition, and Member's Choice.

Events and Happenings

A. The National Comprehensive will be judged based on Design, Craftsmanship, Appearance, Flight Handling, and Flight. Awards will be for Overall Winner, and 1st, 2nd, and 3rd in each of four categories: (1) Box, Winged Box, Cellular, or other rigid framed complex kites, (2) Delta, Delta Derivative, (3) Flat Surfaces with tail, or bowed kites, and (4) Figure, Novelty, or other. The Overall Winner will be the highest score of all entrants. This is for kites made and flown by the entrant (sorry, no entries by proxy).

B. The Dual Line Competition will consist of individual and team events as follows: (1) Individual (Experienced), (2) Individual (Open), (3) Individual Ballet to Music, (4) Team Ballet to Music, and (5) Team Formation. The Individual Experienced and Open Competitions will consist of four compulsory maneuvers and a two-minute freestyle. The groups will be intermixed for judging (draw for flying order), and fly the same routines, with 1st, 2nd, and 3rd place winners selected from each group.

The performance is to be non-stop and flow from one maneuver to the next — so memorize and practice the following sequence of maneuvers:

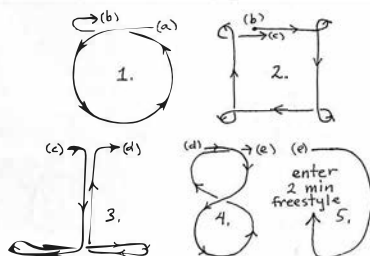

The flyer will enter in the air from the staging area, and exit to the landing area on completion. The figures are to be as large and uniform as possible, and the closer to the ground the better for low passes and the bottom of the square. The vertical eight is to be an "infinity" shape with the center crossing made at a 45-degree slope. Note that the first circle is made counter-clockwise, then a reverse made to enter the square in a clockwise direction, following the direction of the arrows for the rest.

The Individual and Team Ballet routines will be up to the entrant, who must supply a cassette tape of the music to be used. These routines should be a maximum of five minutes. Team Formation competitors will be asked to perform the compulsory maneuvers 1, 2, and 4 before their three-minute freestyle routine.

C. The Member's Choice will be based upon photographs taken Saturday afternoon and displayed on Saturday evening, with voting done prior to the banquet. Categories include: (1) Best Individual Kite, (2) Best Individual Kite Accessory, (3) Best Newly Introduced Manufactured Kite, and (4) Best Newly Introduced Manufactured Kite Accessory. These last two items are to be available on the market and introduced within the last two years.

D. At this time, Kite Challenge Events include (1) The Kite Costume Challenge (sponsored by Al Hargus, III), (2) The Single Line Fighter Kite (by Robert Loera).

E. Kite Happenings include the Night Fly at 10:00 p.m. Thursday, and the Rokkaku Challenge Saturday afternoon.

HEAR YE — HEAR YE

MANUFACTURERS, DISTRIBUTORS, RETAILERS, & OTHERS

Plans are under way to assemble the famous AKA "Goody Bag" to be given to each participant upon arrival at the convention. Most anything is welcome — logo items, advertising giveaways, "things no kiteflyer should be without", etc. If you would like to donate to the "Goody Bag Program", please send your items to: Ms. Izabella Casselman, C/O Outermost Kites, 393 Thames Street, Newport, Rhode Island, 02840. For further information, you may contact Izabella at (401)683-4880.

Kite Plans Made Easy

THE FIGHTER KITE

By Wayne Hosking

Throughout Asia, kite fighting is a way of life and not just a pastime. Thousands of people gather and the sky becomes a sea of kites. Kite fighting can be highly organized with money wagered, or just something to do on a balmy evening. In parts of Japan, kites are so large that teams are required to fly them.

TIPS: The most important part of kite fighting is handling the line. A taut line is easier to cut than a slack one. Kites are maneuvered until the lines touch. A sharp pull and one line will usually give. If your kite is not at an advantageous position, release tension and maneuver the kite out of danger.

The higher the kite, the less control one has. If the kite "falls" out of control, tug hard until the kite is felt on the end of the line.

Tails are not used in kite fighting unless there is a strong wind. Before launching into light wind conditions, gently bend the spine back and hold for a short time. This will stop the kite from "drifting off" in flight.

TAG: A friendly game of tag involves the capturing of the opponents tail with one's line. The captured kite will then lose its wind and control (a foul is when lines cross). Use thin tails made of 1/4" - 1/2" wide crepe paper about 20 feet in length. If the kite fails to stunt with the tail, add paper clips or clay to the kite's bottom at base of spine.

FIGHTING: The object of fighting is to cut away the opponent's kite with one's own line (no blades or other objects are used). In India there is a specially prepared fighting line called MANJA. Thin flying line such as button hold thread or dental floss will do very well for the novice.

TO FLY: Have an assistant hold the kite, by the side corners, downwind 50 - 100 feet. On a given signal have the kite launched with a slight upward push (always keep spare line on the ground for quick feed out). If the kite fails to launch, but the wind is correct, try a small loop above the tow point. Small sharp jabs on the line and released

tension will usually cause the kite to turn. When the kite is facing the required direction pull hard on the line and the kite will travel in that direction. To stop a dive, release tension on the line. With a little practice, the fighter can be maneuvered about the sky at will.

FIGHTER

RATING: 2B with tail; 2D without tail

WIND: Light to moderate

LINE: 6/10 lb. test (2.7/4.5 kg)

MATERIALS: 1 - 18" square plastic sheet
1 - 27 1/2" x 1/8" dowel or bamboo
1 - 21 1/2" x 1/8" dowel or bamboo
1 - bridle line 43"

METHOD:

1. Fold sail in halves. Measure 4" down from top (Y) along the fold and draw a line to the corner X. Cut along line X-Y. (Fig. 1)
2. Measure bridle points from bottom of sail. (Fig 1)
3. Tape spine to kite. (Fig. 3)
4. Reinforce cross strut. (Fig 2)
5. Lay cross strut from corner A and halfway between top of kite and bridle point C. Tape spar at A. Bend spar and tape at B. (Fig. 3)
6. Punch holes on both sides of spine at points C & D. (Fig. 3 & 4) Tie bridle, twice length of kite, around both dowels at C and at D. (Fig. 3)
7. Hold bridle by two fingers with kite flat. (Fig. 5) Move along bridle a half inch forward from the balance point and tie a loop.
8. A tail can be attached at bottom of kite by taping or tying to spine.
9. In light conditions fold kite back and hold. (Fig. 6) This will stop the kite from "drifting off".

CONVERSION:

	1/8 INCH	3	MM		
4	"	10	CM	21 1/2 "	54.75 CM
6	"	15	CM	27 1/2 "	69.75 CM
18	"	45.5	CM	43 "	114.5 CM

Kite Plans Made Easy (continued from page 11)

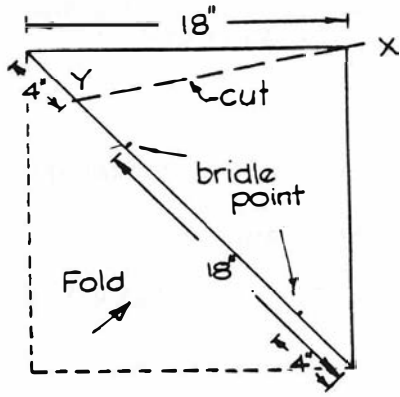
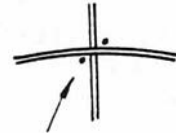
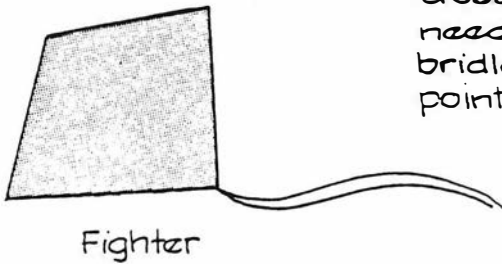

Fig. 1



Punch bridle holes on both sides of spine and cross strut, or use a needle to thread the bridle through these points.

Fig. 4

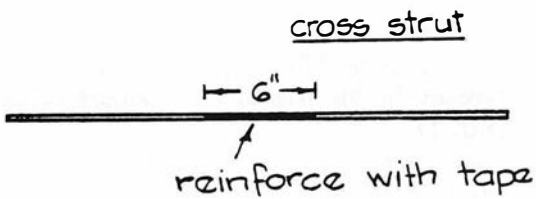
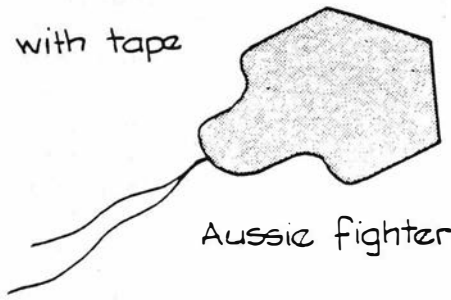

Fig. 2



Aussie fighter

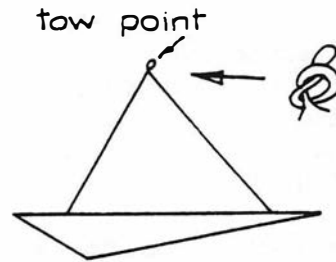

Fig. 5

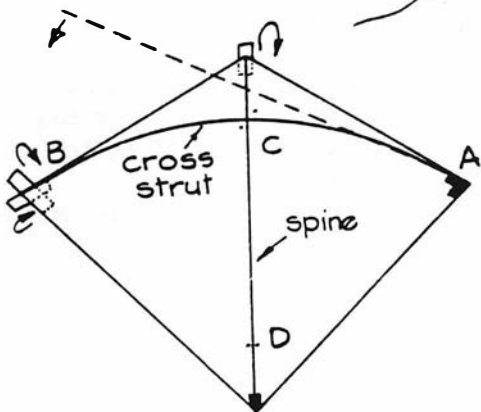
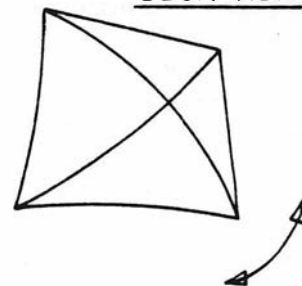

Fig. 3

Back View.



Fold kite back and hold.

Fig. 6

AKA News

AKA Executive Committee Minutes July 7, 1986 As Amended

The Executive Committee of the AKA met at the home of President Margo Brown at 6636 Kirkley Avenue in McLean, Virginia on July 7, 1986 at 7:37 p.m. Present were Margo, Red Braswell, Hamilton Wells, Bevan Brown, Bob Price, and Jewell Price. Kathleen (Kathy) O'Neil and Jon Burkhardt were present part of the time.

The minutes of the June 26, 1986 meeting were read and approved as amended.

Bob Price suggested printing the minutes and By-Laws in smaller print than that used in regular articles. This would provide more space for other articles.

Margo discussed articles, plans, options, pictures, etc. for July KITING. After some discussion it was decided that only the volume and number would be on the front cover, but a publishing date would be included inside the magazine. Inside of dust cover will be used for membership forms.

Kathy O'Neil, a graphics artist, presented a proposal for work she could do to help in publishing KITING.

Jon Burkhardt also presented a proposal from an editor.

Hamilton Wells suggested that a president-elect be elected a year in advance so that there would be some degree of continuity from year to year as administrations change. Also he recommended that officers be installed at the annual meeting and begin their terms immediately. He recommended increasing family membership dues and use of a calendar year membership cycle.

Red Braswell moved that Tom Casselman be authorized to buy two pair of headsets (\$79.95 per set of two at Radio Shack) for use at the Newport Convention. Motion carried.

It was decided to have a special meeting on July 10 to discuss proposed amendments to the By-Laws.

During the discussion with Jon and Kathy concerning their proposals and Jon's experience as editor of the May issue of KITING we learned that many

mistakes were made by Drohan in preparation of material for publication. Some corrections had to be made after material had been sent to the printer. These late corrections were wasteful of time and money. It is hoped this type of error will be avoided in the future.

The meeting was adjourned at 10:30 p.m.

Jewell Price
Recording Secretary

July 25, 1986
August 1, 1986

AKA Executive Committee Minutes July 10, 1986

The Executive Committee of the AKA met at the home of President Margo Brown at 6636 Kirkley Avenue in McLean, Virginia on July 10, 1986 at 6:45 p.m. Present were Margo, Red Braswell, Bob Price and Jewell Price.

The AKA tax filing time was extended, the extension notice having been received on July 10, 1986. The new filing deadline was given as July 15, 1986. The employer identification number (provided by Drohan Management Group) on our extension was incorrect.

Since the May issue of KITING was not sent first class, as directed by the executive committee, it was decided to extend the early registration opportunity for the AKA convention from July 15 to July 31.

Tom Casselman proposed having a large banner (8' x 12') made for use at the convention and other AKA sanctioned events at a cost of \$300.00. The executive committee felt that a decision on this proposal should be postponed until we have a better understanding of our financial status.

The By-Laws Committee presented proposed amendments which, with some changes, were approved for publication in the July issue of KITING. These proposed amendments will be brought before the October AKA convention for action.

The meeting was adjourned at 9:10 p.m.

Jewell Price
Recording Secretary

July 25, 1986

**AKA Executive Committee Minutes
July 28, 1986
Approved as Amended**

The Executive Committee of the AKA met at the home of President Margo Brown at 6636 Kirkley Avenue in McLean, Virginia on July 28, 1986 at 6:35 p.m. Present were Margo, Red Braswell, Bob Price, Hamilton Wells, Don McCasland, and Jewell Price.

Minutes of the July 7, 1986 meeting were approved as amended and minutes of the July 10, 1986 meeting were accepted as presented.

During a visit to the printer to determine if the mailing charges for the May 1986 issue of KITEING were proper, Bob Price was able to have a monetary mistake corrected, thereby providing a substantial portion of the postage pre-payment for the July issue.

Hamilton Wells, who has resigned as treasurer (note attachments), gave an oral report and turned over records to the association. As of July 18, 1986 there was a total of \$2562.75 in the McLean Bank. At the end of July there will be some interest posted. There are about \$6400 in the Sandy Spring National Bank.

The Ben Blinn Fund of \$10,314.09 is separate from the general fund and the Steve Edeiken Fund will be separated when the McLean account is closed. Ham's best estimate of the value of the Edeiken Fund is \$1439.54 as of the 18th of July.

Margo accepted Ham's resignation and expressed deep gratitude for all his work to get our finances in order and properly organized. She also expressed to Hamilton our best wishes for recovery from his vision problems.

Our state and federal tax filings are still unresolved. Margo is pursuing information with a call to Parke and Higham, the accounting firm which was contracted through Drohan Management Group (DMG) to review our finances and file our taxes. The final report and check from the San Diego convention were lost by Paul Thomas. He said the check and report were thrown in the trash by the cleaning lady. He searched the dumpster but it had been emptied. Paul Thomas accepted the responsibility

for the loss by DMG and agreed to contact John and Ila Laing to obtain a replacement check and closure statement. Lack of this report has prevented our filing 1985 tax returns.

A copy of the letter of acceptance of the termination of the contract by DMG will be placed in the archives.

Red Braswell moved that Hamilton Wells's letter of resignation, his final financial report, and his notes of recommendations be made a part of these minutes. Motion carried.

The signature cards for the Ben Blinn Fund have been changed to reflect the removal of Paul Thomas' name and the addition of a third signer. Also the signature cards for the other accounts are being changed.

Bob Price moved that we charge \$2.00 per copy of the AKA publication for the last six issues and \$1.00 for older ones, plus postage. Excepted would be issues with few copies available. Red Braswell moved to amend the motion to change the charges to \$3.00 and \$2.00, which would include postage. Motion, as amended, carried.

Red Braswell moved that Liz Carroll be appointed financial registrar for the 1986 AKA convention in Newport, RI. Also, he moved that Mrs. Tony (Julia) Bisbano be appointed sales agent for the 1986 convention in Newport, RI. Motions carried. It was decided that the Auction Committee would be responsible for providing a credit card machine for the auction.

The meeting was adjourned at 9:20 p.m.

Jewell Price
Recording Secretary

August 5, 1986
August 6, 1986

GRANDMASTER KITES
The Ultimate State of the Art
in Single-Line Maneuverable and Dancing Kites

Hand Painted, Hand-Crafted, Fine Tuned yet Durable
Excels in Winds of 0-20 Miles an Hour

Interested: Contact Joseph Vaughan at P.O. Box 276,
Mifflinville, PA, 18631 or call (717)759-3167.

**AKA Executive Committee Minutes
August 5, 1986**

The Executive Committee of the AKA met at the home of President Margo Brown at 6636 Kirkley Avenue in McLean, Virginia on August 5, 1986 at 6:30 p.m. Present were Margo, Red Braswell, Bob Price, and Jewell Price.

Minutes of the July 28, 1986 meeting were approved as amended. Jewell Price called attention to the following items:

1. The Nominating Committee should prepare ballot information immediately.
2. The Election Committee should be formed immediately.
3. The September issue of KITING must be in mail by end of August if it is to carry the ballot to members and save a special mailing.
4. Sanctioning of the Air Force Museum Fly.
5. Sanctioning of the alternate week flies for the Central Ohio Kitefliers Association.
6. Chicago Skyliners request for hosting 1988 convention.
7. A call for committee reports for the 1986 convention.

Margo contacted Parke and Higham about filing taxes. Parke and Higham said the final report from San Diego Convention is needed before tax returns can be filed. Red Braswell has been attempting to get Drohan Management Group (DMG) to have the check and report from the San Diego Convention replaced. Paul Thomas' response has been unsatisfactory; however, this morning Red was able to meet with William Drohan, President of DMG. Mr. Drohan claimed not to have known of the problem but assured Red that he would make every effort to have them replaced. Mr. Drohan was informed that because of DMG's poor performance, AKA is under a potential \$10 per day fine until the IRS forms are filed. If there has been no solution to the check and final report replacement in about two weeks, the Executive Committee will consider the matter again.

Margo asked that it be recorded in the minutes that Red Braswell was responsible for transferring the AKA telephone from DMG to the Kirkley Avenue address. He also sent change of address cards to various post offices and mail is finally being properly forwarded to AKA at 6636 Kirkley Avenue.

Margo went over the July issue of the magazine and reported that even though a great deal of work had been done it is still not ready for the printer. The Executive Committee authorized Margo to have the July issue finished by Debra Lashbrook, a candidate for editor of the AKA publication.

Judy Neuger has suggested that the membership be notified by postcard that the deadline for the early registration fee of \$60 be extended to August 31, 1986. Bob Price moved that Judy's suggestion be implemented and that the card include information from an article which is to be published in the July issue of KITING.

The meeting was adjourned until 7:00 p.m., August 6, 1986.

Jewell Price
Recording Secretary

August 19, 1986

**AKA Executive Committee Minutes
August 6, 1986**

The Executive Committee of the AKA met at the home of President Margo Brown at 6636 Kirkley Avenue in McLean, Virginia on August 6, 1986 at 7:50 p.m. Present were Margo, Red Braswell, Bob Price, and Jewell Price.

Red reported that, according to Paul Thomas, William Drohan, President of Drohan Management Group (DMG), a certified letter has been sent to Ila Laing confirming a conversation with her in which she indicated she would send a replacement check and another copy of the financial report from San Diego.

Margo stated that at 10:30 p.m. on July 5, 1986, Tom Casselman called her to report on convention progress. Tom is negotiating the contract with the Sheraton Islander Hotel concerning the Friday night meals.

Susan Mayer, Chairperson of the Ways and Means Committee, is working with Tom Casselman to see that patches, T-shirts, pins, etc. are ready for the convention.

Red Braswell moved that we accept the proposal of Debra Lashbrook to edit and publish KITING and that we instruct Margo to sign a contract to that effect. Motion carried.

Bob Price moved that the editor of the AKA publication (**KITING, AKA NEWS, or whatever name is selected**) be given authority to set deadline dates for submission of material for publication so that issuance (mailing) dates of the first day of January, March, May, July, September, and November may be met. The editorial board, authors, officers, etc. may submit material and suggestions up to the deadline date. The editor may establish a publication date so that known material may be inserted at the last possible time if space is reserved. If such material is not delivered by the publication date, the editor will fill the space with previously prepared alternate material.

The deadline and publication dates (which may be the same) for each issue will be announced to the membership at least 30 days in advance of the deadline date. Delay of publication on behalf of the association may be permitted if 6 executive committee members and the editor concur. Motion carried.

Margo reported that she checked with printing companies and found that they charge comparable prices for printing postcards. Bob Price moved that the Executive Committee authorize expenditure by Margo of \$311.50 for postcards and printing. Any money left over will be used to defray other costs involved. Motion carried.

The meeting was adjourned at 9:30 p.m.

Jewell Price
Recording Secretary

August 20, 1986

**FKC
Fighting
Kite Co.**

3116 ARLOTTE AVENUE
LONG BEACH, CA 90808
(213) 596-9360

**LOWEST
PRICE
FIGHTER KITES
IN AMERICA**

*Genuine Indian craftsmanship
in strong glassine paper.*

IN CHAMPIONSHIPS

FIRST PRIZE, INTL. KITE FIGHTING
at SAN FRANCISCO,

10 FIGHTER KITES	\$17.00
50 FIGHTER KITES	\$48.00
100 FIGHTER KITES	\$78.00
500 FIGHTER KITES	\$310.00

ALL KITES 15 INCHES UNBRIDLED
ADD 15% FOR SHIPPING AND HANDLING
CALIF. RESIDENT ADD 6% ADDITIONAL

AKA T-Shirts On Sale



AKA's shirt features a new version of our logo, as interpreted by Fred Bell, in blue and white, on the front and the words "American Kiteflier" printed in white down the sleeves. AKA has purchased a limited quantity of the shirts for sale at \$15.00. Don't be left out. Send your order now to: Red Braswell, 1,000 Lomond Drive, Manassas, Virginia, 22110, or order from Red at (703)361-2671.

Specify small, medium, large or extra large. The shirts are 50% cotton, 50% polyester.

AKA is proud and happy to announce the availability of a limited edition AKA T-shirt. A high-quality long sleeved shirt in bright red, this shirt is sure to be the uniform for serious kites.