

# ALGO

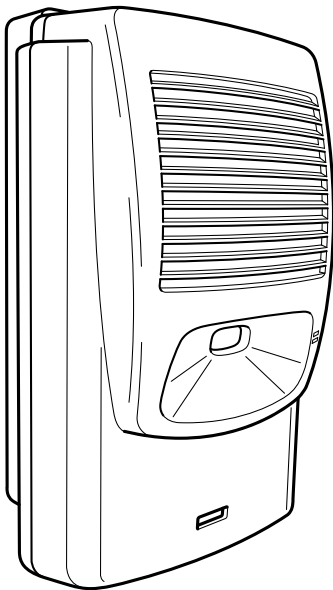

## **8180 SIP Audio Alerter**

### **User Guide**

For Firmware Version 1.1

---

Algo Communication Products Ltd.

90-00041D

# Table of Contents

<b>Overview .....</b>	<b>3</b>
<i>Introduction .....</i>	<i>3</i>
<i>Key Features.....</i>	<i>3</i>
<i>Front and Back Views .....</i>	<i>5</i>
<b>Setup and Installation.....</b>	<b>6</b>
<i>Wall Mounting .....</i>	<i>6</i>
<i>Outputs.....</i>	<i>6</i>
<i>Programming and Configuration .....</i>	<i>7</i>
<b>Web Interface Control Panel .....</b>	<b>9</b>
<i>Config Menu .....</i>	<i>9</i>
<i>Services Menu .....</i>	<i>15</i>
<b>NAT .....</b>	<b>16</b>
<i>STUN Server.....</i>	<i>16</i>
<i>Asterisk and other SIP Servers .....</i>	<i>17</i>
<b>Multicast Configuration .....</b>	<b>18</b>
<i>Setting up Master and Slave units .....</i>	<i>18</i>
<i>Unmanaged Mode .....</i>	<i>20</i>
<b>Auto-Provisioning (via TFTP).....</b>	<b>21</b>
<i>MD5 Checksum.....</i>	<i>21</i>
<i>Generating a generic configuration file .....</i>	<i>22</i>
<i>Generating a specific configuration file.....</i>	<i>22</i>
<b>8180 Firmware .....</b>	<b>23</b>
<i>Upgrade 8180 Firmware .....</i>	<i>23</i>
<b>Appendix .....</b>	<b>24</b>
<i>Multicast Technical Information.....</i>	<i>24</i>
<i>Specifications .....</i>	<i>25</i>
<i>FCC Compliance .....</i>	<i>28</i>
<i>Important Safety Notice .....</i>	<i>28</i>
<i>Optional 8180 Accessories .....</i>	<i>28</i>

# Overview

## Introduction

The 8180 SIP Audio Alerter is a SIP compliant PoE network audio device for loud ring and voice paging applications using dual endpoints. When registered with a SIP server, one endpoint will play an audio file from internal memory upon ring detection. The second endpoint will auto-answer for voice paging, complete with two-way talkback.

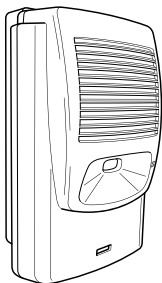

## Key Features

### **Loudness**

Equipped with a high efficiency integrated amplifier and tuned high quality loud speaker, the 8180 is typically eight times louder than a telephone speaker. If the optional 1185 Horn Speaker is used, then the 8180 can be 20 times louder.

### **Audio Files**

Several audio files are pre-loaded into the 8180 internal memory for ring sounds and users may also record or upload custom audio files, music, sound effects, or voice announcements.

### **Ambient Noise Compensation**

The 8180's SoundSure™ technology automatically adjusts loud ring and paging volume to compensate for background ambient noise. If SoundSure™ is enabled, the ambient noise level is measured and recorded at the time that the volume is adjusted. Whenever the 8180 is activated, the alert volume will get louder or quieter by the same dB level as the ambient noise measured just prior to the alert.

## **Outputs for External Equipment and Devices**

Outputs for external speaker, slave amplifier, or visual alerter plus multicasting capability enable many more options to enhance notification and alert capabilities.

## **Configuration & Provisioning**

Configure the 8180 through a web interface control panel or by using the program buttons on the back of the unit. Central provisioning may also be used to allow units to be preconfigured for a specific server prior to deployment in the field. Configuration files are automatically downloaded from a TFTP server using DHCP.

## **Paging Talkback**

Allows bidirectional communication between the 8180 and the phone. Talkback is ideal for confirmation that page announcements have been received.

## **Multicasting**

Allows multiple units to simultaneously ring or play a page audio stream.

## **Blue Indicator Light**

This LED light is on during initialization, boot, message waiting or while active. Ring and Page modes, when active, will turn the LED on steady. If the optional Talkback mode is enabled, the LED will flash instead (during a page event) to provide a clear indication that the microphone is active. If Message Waiting is supported and active, the light will flash, or be on steady (depending on its setting).

---

For comprehensive product and application information, please visit [www.algosolutions.com/8180](http://www.algosolutions.com/8180)

## Front and Back Views

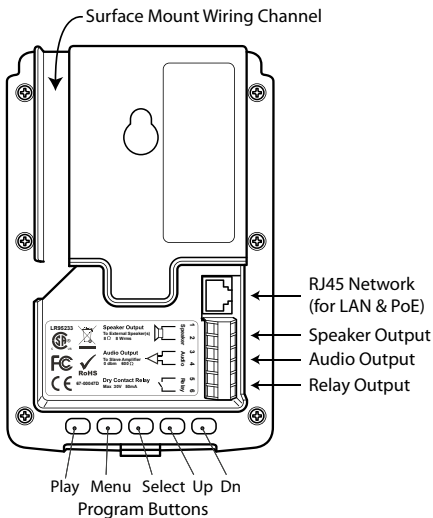
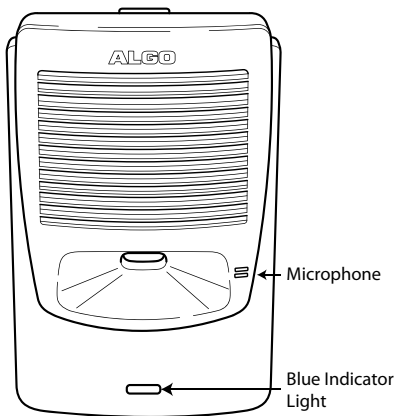

# Setup and Installation

## Wall Mounting

Mount the wall bracket securely and snap the 8180 into the bracket by engaging the top first and then pushing the bottom firmly into place. To remove the 8180 from the bracket, press firmly on the tab of the bottom catch, then lift the cover.

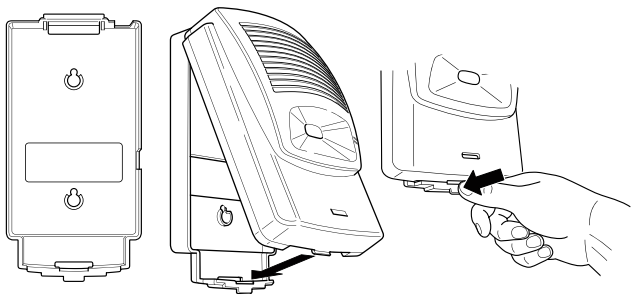

## Outputs

### Relay

May be enabled for ring, paging or both to activate a visual alerter, mute background music, or enable a slave amplifier.

### Auxiliary Speaker

For connection to an external 8  $\Omega$  horn speaker (e.g. for outdoor/wet locations) or to ceiling speakers wired in a series-parallel configuration to maintain minimum 8  $\Omega$ . The presence of an external speaker(s) will automatically disable the internal speaker to preserve power.

### Audio

High impedance output for driving 600  $\Omega$  load up to 0 dBm. Internal speaker may be active simultaneously, but levels can't be adjusted separately.

## Programming and Configuration

Primary configuration of the 8180 is through the web interface control panel. In addition, there are program buttons on the unit itself for basic setup options.

### **Connection to Network and Obtaining IP Address**

After connecting the 8180 to a network PoE port, the blue indicator light will turn on during initialization. The 8180 will then attempt to obtain an IP address from the DHCP server. If unsuccessful, the 8180 will default to the fixed IP address 192.168.1.111. When the IP address is selected, the 8180 will chime and turn off the blue light.



*If you don't have a PoE switch, you'll need a PoE injector that installs between the 8180 and network switch. The PoE injector will supply 48 Vdc to the 8180. Most PoE injectors are capable of providing more power than the 8180 requires (12.95 W). Ensure that the PoE injector is fully compliant to the IEEE 802.3af standard.*

### **Web Interface Control Panel**

The 8180 is configured using a web interface tool accessed by entering the 8180 IP address into a browser.

To find this IP address, press the Menu button until the option for "IP Address" is reached. Then press Select to hear the address. Alternatively, search the network using the Algo Network Device Locator Tool available for download from [www.algosolutions.com/locator](http://www.algosolutions.com/locator).

## **Program Buttons**

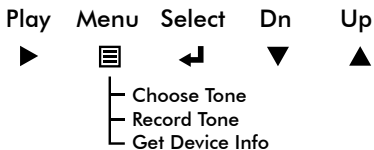

The Program buttons on the back of the 8180 allow local adjustment of alert tones and alert volume. The buttons are intentionally hidden from view after installation and can be disabled using the web interface.

The ▶ button plays the current ring tone and allows volume adjustment using the ▼ and ▲ buttons. Press ▶ to exit.

The ☰ button steps through the following three options:

1. Choose ring tone
2. Record ring tone using microphone
3. Get device information (IP address and MAC address)

Press the ↩ button to choose option or ▶ to exit.



# Web Interface Control Panel

Using the SIP Audio Alerter web interface control panel, configure the 8180 network settings and select the desired options. These settings survive power cycling and may be programmed in advance prior to site installation.



*After changing settings, click Save Settings (at top or bottom of page). Note that this will end any active call. To change and test volume levels during an active call, press the Adjust buttons next to these settings instead.*

The following tables provide information on each of the options in the control panel:

## Config Menu

### SIP

SIP	
<input type="checkbox"/> SIP Domain/Proxy:	10.0.0.10
Outbound Proxy (optional):	
STUN Server (optional): ⓘ	
Registrar (optional):	
Register Period (seconds):	3600
Different Ports for Extensions: ⓘ	<input type="radio"/> On <input checked="" type="radio"/> Off
Keep-alive Method:	<input checked="" type="radio"/> None <input type="radio"/> Double CRLF
Keep-alive Period (seconds):	30
<input type="checkbox"/> Ring Detect Extension:	1502
Auth ID:	VHL8012
Password:	●●●●●●●●
<input type="checkbox"/> Page Audio Extension:	1503
Auth ID:	VHL8013
Password:	●●●●●●●●

<b>SIP Domain/Proxy</b>	SIP Server Name or IP address
<b>Outbound Proxy (optional)</b>	Outbound proxy is a proxy (server) that stands between a private network and the Internet.
<b>STUN Server (optional)</b>	Allow communication between SIP server and 8180 if NAT is present. See "NAT" on page 16.

<b>Registrar (optional)</b>	A registrar is a server that accepts REGISTER requests from SIP devices. Configure Registrar if the SIP Proxy does not accept REGISTER requests.
<b>Register Period (seconds)</b>	Maximum requested period of time where the 8180 will re-register with the SIP server. Default setting is 3600 seconds (1 hour). Only change if instructed otherwise.
<b>Different Ports for Extensions</b>	Turn this option ON for certain proxies. For example: Cisco Communication Manager to send ring and page SIP requests through different port numbers.
<b>Keep-alive Method</b>	Maintain connection between the 8180 and the SIP Server if the 8180 is behind NAT. See "NAT" on page 16.
<b>Keep-alive Period (seconds)</b>	Period of time where the 8180 will send some information to the SIP Server to keep the connection alive.
<b>Ring Detect Extension</b>	Extension name that will be monitored to activate the 8180 ring. Cannot auto-answer.
<b>Page Audio Extension</b>	Extension name that will be monitored to activate the 8180 page auto-answer.
<b>Auth ID</b>	Authentication ID; Used to register the device on the SIP Server.
<b>Password</b>	SIP password used to register the device on the SIP Server.

## Features

**Features**

Ring Tone: 1202.wav

Ring Volume: 2

Ambient Noise Compensation:  On  Off

Page Volume: 5

Page Timeout: None

Page Mode:  One-way  Talkback

Page Tone: page-notif.wav

Message Waiting Light:  None  On  Flash

Message Waiting Event:  Any  Status Line  New Message

Multicast Mode:  None  Master  Slave  Unmanaged

Speaker Mode:  Auto  External  Internal  Disabled

Relay Mode:  Both  Ring  Page  Disabled

Provisioning via DHCP:  On  Off

Hold Button to Play:  On  Off

<b>Ring Tone</b>	Selection of files that can be played when ring detect is activated.
<b>Ring Volume</b>	Ring volume can be selected and saved, or it can be adjusted live by clicking on "Adjust".
<b>Ambient Noise Compensation (SoundSure™)</b>	When activated, adjusts the ring or page volume depending on the ambient noise.
<b>Page Volume</b>	Page volume can be selected and saved, or it can be adjusted live by clicking on "Adjust".
<b>Page Timeout</b>	Hang up call after the preselected period of time.
<b>Page Mode</b>	<p><b>One-way audio:</b> Transmission only; from the phone to the 8180.</p> <p><b>Talkback:</b> Allow half-duplex communication through the 8180 (direction based on voice detection). The communication can only be initiated from a phone.</p>

<b>Page Tone</b>	Selection of different page tones. Page tones are played before starting the paging. Select None to skip playing a page tone.
<b>Message Waiting Light</b>	Will activate the 8180 front light when there is a message waiting signal on the line. Function available if supported by the SIP server.
<b>Message Waiting Event</b>	Message Waiting Light can be activated by a Status Line, New Message, or both (if supported by SIP Server).
<b>Multicast Mode</b>	See "Multicast Configuration" on page 18.
<b>Speaker Mode</b>	Auto: Detect automatically if a external speaker is connected to the 8180.
<b>Relay Mode</b>	Relay activation: Ring, Page, Both, or disabled. Relay can trigger external light or other device when specified event occurs.
<b>Provisioning via DHCP (TFTP Deployment)</b>	See "Auto-Provisioning (via TFTP)" on page 21.
<b>Hold Button to Play</b>	Hold or press Play button to play current ring tone.

## Network

Network	
DHCP	<input type="radio"/> On <input checked="" type="radio"/> Off
IP Address:	<input type="text"/>
Netmask:	<input type="text"/>
Gateway:	<input type="text"/>
DNS 1:	<input type="text"/>
DNS 2:	<input type="text"/>
	<input type="checkbox"/> Advanced Settings
	DHCP Timeout (seconds): <input type="text" value="60"/>
	NTP Server: <input type="text"/>

<b>DHCP</b>	Dynamic Host Configuration Protocol (DHCP) is an IP standard designed to make administration of IP addresses simpler. Normally set to On, DHCP will automatically configure IP addresses for each 8180 on the network. Alternatively, if your IT Administrator has assigned one or more <i>static</i> IP addresses, set the DHCP setting to Off.
<b>DHCP Timeout (seconds)</b>	Length of time following a request from an 8180 to the DHCP server that the 8180 will wait before assuming the server is not available. After such time, the 8180 will use its default address of 192.168.1.111  Default is 60 seconds.
<b>NTP Server</b>	Network Time Protocol server IP address. Allows device to automatically set its clock by connecting to an external server.

## Admin

Admin	
Device Name: ⓘ	<input type="text" value="sipalerter"/>
Password:	<input type="password" value="••••"/>
Re-type Password:	<input type="password" value="••••"/>
Program Buttons:	<input checked="" type="radio"/> Enabled <input type="radio"/> Disabled
Advanced Settings	
Log Level:	<input checked="" type="radio"/> Error <input type="radio"/> Info <input type="radio"/> Debug
Log Size (1~1000 KB):	<input type="text" value="100"/>
Log Method:	<input type="radio"/> Local <input type="radio"/> Network <input checked="" type="radio"/> Both
Log Server IP:	<input type="text"/>
Language:	<input type="text" value="English"/>
Voice Prompt:	<input type="text" value="English"/>

<b>Device Name</b>	Name to identify the device on the network (similar to "Computer Name" field in Windows).
<b>Password</b>	Password to log into the 8180 web interface. You should change the default password in order to secure the device on the network. If you have forgotten your password, a soft reset will restore the default setting (including <i>all</i> of the device's default settings). To do this, disconnect the network cable from the 8180. Push and hold the Volume Down button and reconnect the network cable. Hold the button until the front light flashes three times.
<b>Program Buttons</b>	Enable or disable the Program Buttons on the back of the 8180.
<b>Log Level</b>	Amount of information provided in the log files.
<b>Language</b>	Set Web Interface language (More languages will be added in the future. Please contact Algo with your request.)
<b>Voice Prompt</b>	Set Voice Prompt language (More languages will be added in the future. Please contact Algo with your request.)

# Services Menu

Settings

When reset, delete all ringtones

Reset Reset All Settings to Factory Default

Reboot Reboot the Device

Save Log Messages: Page 1 Page 2

Save Settings to File: Backup Settings

Restore Settings from File: Restore Settings

Browse..

Upgrade

File: [ ] Browse..

MDS: [ ] Browse..

## Settings

<b>Save Log Messages</b>	Show or save log files
<b>Save Settings to File</b>	Save the device settings to a text file for backup or to setup an auto-provisioning configuration file.
<b>Restore Settings from File</b>	Restore settings from a backup file.

## Upgrade

<b>Upgrade</b>	Refer to "8180 Firmware" on page 23
----------------	-------------------------------------

# NAT



NAT (Network Address Translation) is located between a private network and the Internet. When properly configured, it allows an 8180 installed on a private network to have access to the outside world, such as would be required when using a hosted SIP provider (i.e. a SIP server that is remotely located).

Algo provides NAT support for both STUN and Asterisk. To configure NAT for the server that applies to your application, follow these steps:

## STUN Server

1. Enter the STUN Server name or IP address
2. Set Keep-alive Method to None
3. Click Save Settings

### SIP

 SIP Domain/Proxy:	<input type="text" value="10.0.0.10"/>
Outbound Proxy (optional):	<input type="text"/>
STUN Server (optional): 	<input type="text" value="10.0.0.30"/>
Registrar (optional):	<input type="text"/>
Register Period (seconds):	<input type="text" value="3600"/>
Use Same Port: 	<input checked="" type="radio"/> On <input type="radio"/> Off
Keep-alive Method:	<input checked="" type="radio"/> None <input type="radio"/> Double CRLF
Keep-alive Period (seconds):	<input type="text" value="30"/>



## Asterisk and other SIP Servers

1. Set Keep-alive Method to Double CRLF
2. Set Keep-alive Period to 30
3. Click Save Settings

SIP

---

SIP Domain/Proxy:

Outbound Proxy (optional):

STUN Server (optional):  ⓘ

Registrar (optional):

Register Period (seconds):

Use Same Port: ⓘ  On  Off

Keep-alive Method:  None  Double CRLF

Keep-alive Period (seconds):

---



*The NAT library sends the binding requests for each port every 30 seconds to ensure NAT mapping is valid all the time.*

# Multicast Configuration

## Setting up Master and Slave units

To set up multicasting, first configure a single 8180 unit as a master, then set up one or more 8180s as slaves. To do this:

1. Set the 8180 that you want to use as the master with normal Ring and Page line definitions

**SIP**

SIP Domain/Proxy: 10.0.0.12

Outbound Proxy (optional):

STUN Server (optional):

Registrar (optional):

Register Period (seconds): 3600

Different Ports for Extensions:  On  Off

Keep-alive Method:  None  Double CRLF

Keep-alive Period (seconds): 30

Ring Detect Extension: 1503

Auth ID:

Password: ●●●●

Page Audio Extension:

Auth ID:

Password:

2. On the same unit, set the Multicast Mode to Master

Multicast Mode:  None  Master

Slave  Unmanaged

Multicast Zone:

3. Configure one or more 8180s to Slave Mode. Ring and Page for these slave devices do not have to be defined.

Multicast Mode:  None  Master

Slave  Unmanaged

Multicast Zone:



*The Multicast Zone must always be the same on both Master and Slave(s).*

## **Multicast Zone**

In most cases, you will be able to leave the default Multicast Zone setting unchanged. For more information on this, please refer to “Multicast Technical Information” on page 24.

### **Master and Slave Multicast Operation**

Once the configuration is complete, each time the master 8180 receives a:

- Ring signal, all the master and slave units will play their current ring tone
- Page audio stream, all the master and slave units will play the audio

Slave units have independent ring tone and volume settings. The ring tone played on a slave unit is the currently selected tone and volume level of that unit.

For example, if the Chime tone is chosen on Slave 1 at volume level 10, and the Gong tone on Slave 2 at volume level 5, when they receive a ring signal from the master 8180, Slave 1 will play the Chime tone at volume 10 while Slave 2 will play the Gong tone at volume 5.

## Unmanaged Mode

Multicast Mode:  None  Master  
 Slave  Unmanaged

Multicast Zone: ⓘ

This mode allows 8180s to play an audio (RTP) stream from a source other than an 8180. For example, you can use the Unmanaged Mode to play audio from another phone on the switch that is generating a page to other phones using multicast.

### ***Multicast Unmanaged Mode Operation***

In Unmanaged Mode, the 8180 will start listening on the multicast zone and will play any RTP  $\mu$ Law or A-law audio stream. Once it detects audio, the 8180 will first play a page tone (if configured) and then open the audio channel. When the audio stream stops for at least 2 seconds, the audio channel is closed and the 8180 returns to its normal idle state where it again listens for a new page or for ring or other events.

# Auto-Provisioning (via TFTP)

Auto-provisioning allows installers to pre-configure 8180 units prior to installation on a network. It is typically used for large deployments.

If desired, 8180 configuration files can be automatically downloaded from a TFTP (Trivial File Transfer Protocol) server using DHCP Option 66. Option 66 is a term used by some DHCP vendors to describe DHCP code 66. This option code (when set) supplies a TFTP boot server address to the DHCP client to boot from.



*DHCP must be enabled in order for Auto-provision to work.*

One of two files can be uploaded on the TFTP server:

1. generic file *algop8180.conf*, or
2. specific file *algom[MAC].conf*

## MD5 Checksum

In addition to the .conf file, an .md5 checksum file must also be uploaded to the TFTP server. This checksum file is used to verify that the .conf file is transferred correctly without error.

A tool such as can be found at <http://www.fourmilab.ch/md5> may be used to generate this file.

## Generating a generic configuration file

1. Connect an 8180 on the network
2. Access the 8180 web interface
3. Configure the 8180 with desired options
4. Click on the Services tab and then on Backup Settings
5. Save the file *settings.txt*
6. Rename file *settings.txt* to *algot8180.conf*
7. File *algot8180.conf* can now be uploaded on the TFTP server



*If using a generic configuration file, extensions and credentials have to be entered manually once the 8180 has automatically downloaded the configuration file.*

## Generating a specific configuration file

1. Follow steps 1 to 5 as listed in the section “Generating a generic configuration file” on page 22.
2. Rename file *settings.txt* to *algot[MAC address].conf* (e.g. *algot0022EE020009.conf*)
3. File *algot[MAC address].conf* can now be uploaded on the TFTP server.



*The specific configuration file will only be downloaded by the 8180 with the MAC address specified in the configuration file name. Since all the necessary settings can be included in this file, the 8180 will be ready to work immediately after the configuration file is downloaded. The MAC address of each 8180 can be found on the back label of the unit.*

# 8180 Firmware

Periodically, new firmware for the 8180 is released that either offers new functionality or addresses problems.

To determine if there is firmware available for the 8180, please visit [www.algosolutions.com/8180](http://www.algosolutions.com/8180)

## Upgrade 8180 Firmware

1. From the top menu, click on Services



2. Click Reboot



Wait 30-60 seconds for the device to reboot and the webpage to automatically reload.

3. Login to the device again, and click on Services.
4. In the Upgrade section, click on Browse and select the 8180 firmware file to upload. Note that both the FW firmware and MD5 checksum files must be loaded.



5. Click Start Upgrade
6. After the upgrade is complete, confirm that the firmware version has changed (refer to top right of Control Panel).

# Appendix

## Multicast Technical Information

Each 8180 has its own IP address, and shares a common multicast IP and port number (multicast zone) for multicast packets.

The master unit transmits to the multicast zone, and all the slave units listen to the multicast zone. When a master unit receives a valid SIP ring event, it will ring locally and also send out a special packet to the multicast zone. The network switches and router see the packet and deliver it to all the members of the group. When a page audio call occurs, the master unit will transmit all the RTP audio packets to the multicast zone and all the slave units will receive them.

The multicast IP and port number must be the same on all the master and slave units of one group. The user may define multiple zones by picking different multicast IP addresses and/or port numbers.

1. Multicast IP addresses range: 224.0.0.0/4  
(from 224.0.0.0 to 239.255.255.255)
2. Port numbers range: 1 to 65535
3. By default, the 8180 is set to use the multicast IP address 224.0.2.60 and the port number 50000



*Make sure that the multicast IP address and port number do not conflict with other services and devices on the same network.*



## Specifications

<b>Power Input</b>	48 V PoE Class 0 (Max 12.95 W - Idle 1 W)
<b>Sound Pressure Level (dBA at 1 m)</b>	106 dBA internal speaker 120 dBA external horn speaker
<b>Internal Memory</b>	<ul style="list-style-type: none"><li>• 6 minutes @ 8 kHz sampling 8-bit <math>\mu</math>-Law audio</li></ul> 3 MB <ul style="list-style-type: none"><li>• 90 seconds @ 16 kHz sampling 16 bit linear audio</li></ul>
<b>Relay Output</b>	Max 30 V 50 mA
<b>Speaker Output</b>	5.5 Wrms 8 Ohm (auto-detection disconnects internal speaker)
<b>Audio Output</b>	0 dBm into 600 Ohm load
<b>Ring Tones (Shipping with 8180)</b>	<ul style="list-style-type: none"><li>• Bell NA</li><li>• Bell UK</li><li>• Buzzer</li><li>• Chime</li><li>• Dogs</li><li>• Gong</li><li>• Warble1 (low)</li><li>• Warble2 (medium)</li><li>• Warble3 (high)</li><li>• Warble4 (trill)</li></ul>
<b>Environmental</b>	0-40° C; 10-95% RH non-condensing; Indoor use only (horn speaker may be located outdoors)
<b>NAT</b> (Network Address Translation)	STUN, Asterisk
<b>Compliance</b>	EN60950:2001, IEEE 802.3-2008, RFC3261, RoHS, CE, FCC, CSA (USA & Canada)

*In the interests of continuing product improvement, specifications are subject to change without notice.*



For more in-depth information on the 8180, including application notes and FAQ, please visit [www.algosolutions.com/8180](http://www.algosolutions.com/8180)

## Dimensions - Front and Side

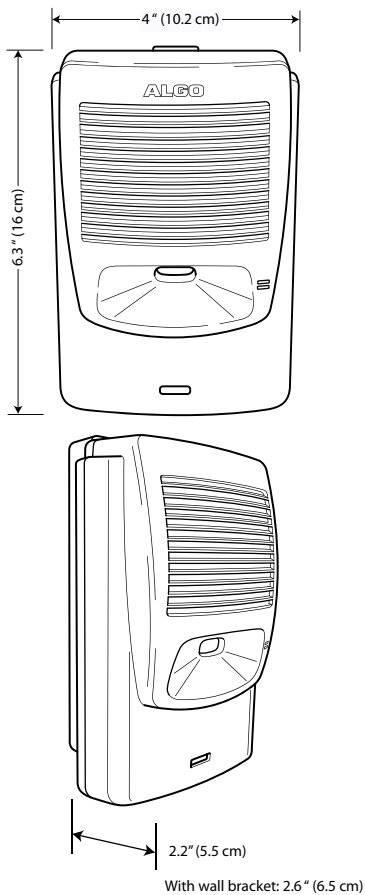

## Dimensions - Wall Bracket

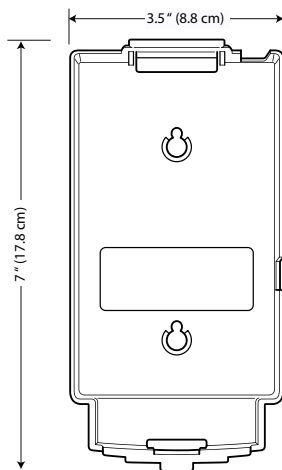

## FCC Compliance

This equipment has been tested and found to comply with the limits for a Class A digital device, pursuant to part 15 of the FCC Rules. These limits are designed to provide reasonable protection against interference in a residential installation. This equipment generates, uses, and can radiate radio frequency energy and, if not installed and used in accordance with the instructions, may cause harmful interference to radio communications. However, there is no guarantee that interference will not occur in a particular installation. If this equipment does cause harmful interference to radio or television reception, which can be determined by turning the equipment off and on, the user is encouraged to try to correct the interference by one or more of the following measures: 1) Reorient or relocate the receiving antenna, 2) Increase the separation between the equipment and receiver, 3) Connect the equipment into an outlet on a circuit different from that to which the receiver is connected, or 4) Consult the dealer or an experienced radio/TV technician for help.

## Important Safety Notice



*The 8180 is intended for installation in a dry indoor location with all connected wiring located within the perimeter of a building.*

*The 8180 is a Power over Ethernet (PoE) device. The PoE power source must be a Limited Power Source (LPS), provided by CAT5 UTP cable, and isolated from mains by minimum reinforced or double insulation. Ensure that the PoE injector or PoE enabled switch carries safety regulatory approval marks (ie CSA, UL, CE).*

## Optional 8180 Accessories

**1185 Horn  
Speaker**

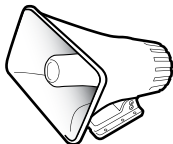

[algosolutions.com/1185](http://algosolutions.com/1185)

**1127 Visual  
Alerter**

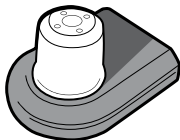

[algosolutions.com/1127](http://algosolutions.com/1127)

**1126 Strobe Light**



[algosolutions.com/1126](http://algosolutions.com/1126)

# ALGO

Algo Communication Products Ltd.  
4500 Beedie Street  
Burnaby, BC Canada V5J 5L2  
[www.algosolutions.com](http://www.algosolutions.com)