

Altivar ATV IMC Drive Controller Programming Guide

04/2014



E100000000390.08

www.schneider-electric.com

Schneider
Electric

The information provided in this documentation contains general descriptions and/or technical characteristics of the performance of the products contained herein. This documentation is not intended as a substitute for and is not to be used for determining suitability or reliability of these products for specific user applications. It is the duty of any such user or integrator to perform the appropriate and complete risk analysis, evaluation and testing of the products with respect to the relevant specific application or use thereof. Neither Schneider Electric nor any of its affiliates or subsidiaries shall be responsible or liable for misuse of the information contained herein. If you have any suggestions for improvements or amendments or have found errors in this publication, please notify us.

No part of this document may be reproduced in any form or by any means, electronic or mechanical, including photocopying, without express written permission of Schneider Electric.

All pertinent state, regional, and local safety regulations must be observed when installing and using this product. For reasons of safety and to help ensure compliance with documented system data, only the manufacturer should perform repairs to components.

When devices are used for applications with technical safety requirements, the relevant instructions must be followed.

Failure to use Schneider Electric software or approved software with our hardware products may result in injury, harm, or improper operating results.

Failure to observe this information can result in injury or equipment damage.

© 2014 Schneider Electric. All rights reserved.

Table of Contents



	Safety Information	5
	About the Book	7
Chapter 1	About the Altivar ATV IMC Drive Controller	11
	Altivar ATV IMC Drive Controller	11
Chapter 2	How to Configure the Controller	13
	How to Configure the Controller	13
Chapter 3	Create an ATV IMC Program with the ATV Template ..	15
	Create an Altivar ATV IMC Drive Controller Application	16
	Overview of the ATV Template	17
	Program Organisation Unit (POU)	18
Chapter 4	Libraries	21
	Automation Libraries	21
Chapter 5	Supported Standard Data Types	23
	Supported Standard Data Types	23
Chapter 6	Memory Mapping	25
	Memory Organization	25
Chapter 7	Tasks	27
	Maximum Number of Tasks	28
	Task Configuration Screen	29
	Task Types	31
	System and Task Watchdogs	33
	Task Priorities	34
	Default Task Configuration	35
Chapter 8	Controller States and Behaviors	37
8.1	Controller State Diagram	38
	Controller State Diagram	39
8.2	Controller States Description	45
	Controller States Description	45
8.3	State Transitions and System Events	49
	Controller States and Output Behavior	50
	Commanding State Transitions	53
	Error Detection, Types, and Management	58
	Remanent Variables	60

Chapter 9	Controller Device Editor	61
	Controller Parameters	62
	Controller Selection	64
	Services	66
Chapter 10	Local Input/Output Configuration	67
	Local I/O Configuration	68
	Addressing	70
Chapter 11	Local HSC Configuration	71
	HSC Types	72
	HSC Configuration Screen Description	73
Chapter 12	ATV IMC Resident Drive Data Configuration	75
	ATV IMC Resident Drive Configuration and Usage	76
	ATV IMC Display Data Configuration and Usage	78
	ATV IO Option Board	80
Chapter 13	Ethernet Configuration	81
	Ethernet Services	82
	IP Address Configuration	84
	Modbus TCP Slave Device	89
	Modbus TCP Server	92
	System Variables Description	94
Chapter 14	ATV IMC Web Server	103
	Web Server	104
	Monitoring Page	108
	Diagnostics Page	113
	Setup Page	114
	Documentation Page	118
Chapter 15	CANopen	119
	CANopen Interface Configuration	119
Chapter 16	Connecting ATV IMC to a PC	123
	Connecting the Altivar ATV IMC Drive Controller to a PC	123
Chapter 17	Changing the ATV IMC Firmware	129
	Changing the Altivar ATV IMC Drive Controller Firmware with ATVIMC_Firmware_Loader_V1.0.exe	130
	Changing the Altivar ATV IMC Drive Controller firmware with SoMachine Central	133
Chapter 18	Compatibility	135
	Software and Firmware Compatibilities	135
	Glossary	137
	Index	145

Safety Information



Important Information

NOTICE

Read these instructions carefully, and look at the equipment to become familiar with the device before trying to install, operate, or maintain it. The following special messages may appear throughout this documentation or on the equipment to warn of potential hazards or to call attention to information that clarifies or simplifies a procedure.



The addition of this symbol to a Danger safety label indicates that an electrical hazard exists, which will result in personal injury if the instructions are not followed.



This is the safety alert symbol. It is used to alert you to potential personal injury hazards. Obey all safety messages that follow this symbol to avoid possible injury or death.

DANGER

DANGER indicates an imminently hazardous situation which, if not avoided, **will result in** death or serious injury.

WARNING

WARNING indicates a potentially hazardous situation which, if not avoided, **can result in** death or serious injury.

CAUTION

CAUTION indicates a potentially hazardous situation which, if not avoided, **can result in** minor or moderate injury.

NOTICE

NOTICE is used to address practices not related to physical injury.

PLEASE NOTE

Electrical equipment should be installed, operated, serviced, and maintained only by qualified personnel. No responsibility is assumed by Schneider Electric for any consequences arising out of the use of this material.

A qualified person is one who has skills and knowledge related to the construction and operation of electrical equipment and its installation, and has received safety training to recognize and avoid the hazards involved.

About the Book



At a Glance

Document Scope

The purpose of this document is to:

- show you how to program and operate the ATV IMC,
- help you understand how to program the ATV IMC functions,
- help you become familiar with the ATV IMC functions.

NOTE: Read and understand this document and all related documents before installing, operating, or maintaining the ATV IMC.

Validity Note

This document has been updated with the release of SoMachine V4.1.

Related Documents

Title of Documentation	Reference Number
SoMachine Programming Guide	EIO0000000067 (ENG); EIO0000000069 (FRE); EIO0000000068 (GER); EIO0000000071 (SPA); EIO0000000070 (ITA); EIO0000000072 (CHS)
ATV IMC Drive Controller Hardware Guide	S1A10252 (ENG); S1A34915 (FRE); S1A34916 (GER); S1A34918 (SPA); S1A34917 (ITA); S1A34919 (CHS)
ATV IMC Drive Controller System Functions and Variables ATV-IMC PLCSystem Library Guide	EIO0000000596 (ENG); EIO0000000597 (FRE); EIO0000000598 (GER); EIO0000000599 (SPA); EIO0000000600 (ITA); EIO0000000601 (CHS)
ATV IMC Drive Controller High Speed Counting ATV-IMC HSC Library Guide	EIO0000000602 (ENG); EIO0000000603 (FRE); EIO0000000604 (GER); EIO0000000605 (SPA); EIO0000000606 (ITA); EIO0000000607 (CHS)

Title of Documentation	Reference Number
SoMachine Modbus and ASCII Read/Write Functions PLCCommunication Library Guide	EIO0000000361 (ENG); EIO0000000742 (FRE); EIO0000000743 (GER); EIO0000000745 (ITA); EIO0000000744 (SPA); EIO0000000746 (CHS)
Altivar 61 Communication Manual	1760661 (ENG)
Altivar 71 Communication Manual	1755861 (ENG)
SoMachine Compatibility and Migration User Guide	EIO0000001684 (ENG); EIO0000001685 (FRE); EIO0000001686 (GER); EIO0000001687 (ITA); EIO0000001688 (SPA); EIO0000001689 (CHS)

You can download these technical publications and other technical information from our website at www.schneider-electric.com.

Product Related Information

 WARNING
<p>LOSS OF CONTROL</p> <ul style="list-style-type: none"> ● The designer of any control scheme must consider the potential failure modes of control paths and, for certain critical control functions, provide a means to achieve a safe state during and after a path failure. Examples of critical control functions are emergency stop and overtravel stop, power outage and restart. ● Separate or redundant control paths must be provided for critical control functions. ● System control paths may include communication links. Consideration must be given to the implications of unanticipated transmission delays or failures of the link. ● Observe all accident prevention regulations and local safety guidelines.¹ ● Each implementation of this equipment must be individually and thoroughly tested for proper operation before being placed into service. <p>Failure to follow these instructions can result in death, serious injury, or equipment damage.</p>

¹ For additional information, refer to NEMA ICS 1.1 (latest edition), "Safety Guidelines for the Application, Installation, and Maintenance of Solid State Control" and to NEMA ICS 7.1 (latest edition), "Safety Standards for Construction and Guide for Selection, Installation and Operation of Adjustable-Speed Drive Systems" or their equivalent governing your particular location.

WARNING

UNINTENDED EQUIPMENT OPERATION

- Only use software approved by Schneider Electric for use with this equipment.
- Update your application program every time you change the physical hardware configuration.

Failure to follow these instructions can result in death, serious injury, or equipment damage.

Chapter 1

About the Altivar ATV IMC Drive Controller

Altivar ATV IMC Drive Controller

Introduction

The Altivar ATV IMC Drive Controller (ATV IMC: Altivar Integrated Machine Controller) is an option card which can be installed in the Altivar 61 or the Altivar 71 drive. It can be combined with another option card (I/O extension or communication).

NOTE: The ATV IMC is compatible with drives containing a firmware version greater than or equal to V3.3ie43.

Only one Altivar ATV IMC Drive Controller option card can be installed on a drive.

The Altivar ATV IMC Drive Controller is used to adapt the variable speed drive to specific applications by integrating control system functions.

Key Features

The Altivar ATV IMC Drive Controller supports the following IEC61131-3 programming languages using the SoMachine software:

- IL: Instruction List
- ST: Structured Text
- FBD: Function Block Diagram
- SFC: Sequential Function Chart
- LD: Ladder Diagram

SoMachine software can also be used to program the controller using CFC (Continuous Function Chart) language.

The Altivar ATV IMC Drive Controller can manage up to 9 tasks.

The Altivar ATV IMC Drive Controller includes the following features using the SoMachine software:

- 10 digital inputs (2 inputs can be used for 2 counters or 2 inputs can be used for 2 incremental encoders)
- 2 analog inputs
- 6 digital outputs
- 2 analog outputs
- A master port for the CANopen bus
- A mini-USB B port for programming with SoMachine software
- An Ethernet port to be used for programming with SoMachine software or Modbus TCP communication.

The Altivar ATV IMC Drive Controller can also use:

- The drive I/O
- The I/O extension card (I/O basic and I/O extended)
- The encoder interface card points counter
- The drive parameters (speed, current, torque, etc.)
- The drive remote keypad (as application HMI).

Compatible Option Cards

This table provides the references of the ATV 61/71 option cards compatible with the Altivar ATV IMC Drive Controller:

Reference	Option Card Description
VW3A3201	Logic (digital) I/O card
VW3A3202	Extended I/O card
VW3A3303	Modbus ASCII communication card
VW3A3310D	Modbus TCP/IP Daisy-Chain Ethernet card
VW3A3304	Interbus communication card
VW3A3316	Ethernet IP communication card
VW3A3309	DeviceNet communication card
VW3A3307	Profibus DP communication card
VW3A3307S371	Profibus DP V1 communication card

Features of the Altivar ATV IMC Drive Controller

This table lists the features of the Altivar ATV IMC Drive Controller drive controller:

Reference	Power Supply	Ethernet Interface	CANopen Master	Digital Inputs	Digital Outputs	Analog Inputs	Analog Outputs	Memory Size
VW3A3521	24 Vdc	yes	yes	10	6	2	2	3 MB

Chapter 2

How to Configure the Controller

How to Configure the Controller

Introduction

First, create a new project or open an existing project in the SoMachine software.

Refer to the *SoMachine Programming Guide* for information on how to:

- add a controller to your project
- add expansion modules to your controller
- replace an existing controller
- convert a controller to a different but compatible device

You can also start a new project using the ATV Template (*see page 15*).

NOTE: Use the ATV Template when starting a new project with an ATV IMC Controller.

Devices Tree

The **Devices tree** shows a structured view of the current hardware configuration. When you add a controller to your project, a number of nodes are automatically added to the **Devices tree**, depending on the functions the controller provides.

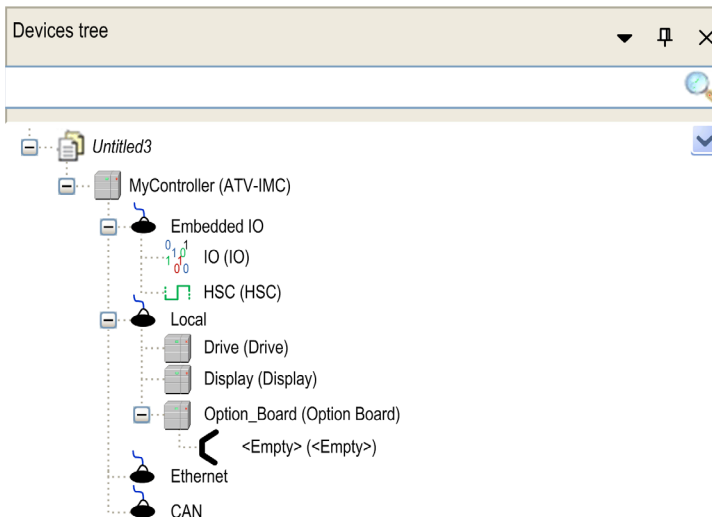

Item	Description
Embedded IO	Shows the Embedded IO functions of the ATV IMC.
Local	Shows the local drive data configuration.
Ethernet CAN	Embedded communications interfaces.

Applications Tree

The **Applications tree** allows you to manage project-specific applications as well as global applications, POU's, and tasks.

Tools Tree

The **Tools tree** allows you to configure the HMI part of your project and to manage libraries.

Chapter 3

Create an ATV IMC Program with the ATV Template

Overview

This chapter describes how to create an Altivar ATV IMC Drive Controller application using the ATV Template program.

What Is in This Chapter?

This chapter contains the following topics:

Topic	Page
Create an Altivar ATV IMC Drive Controller Application	16
Overview of the ATV Template	17
Program Organisation Unit (POU)	18

Create an Altivar ATV IMC Drive Controller Application

ATV Template Usage

When an Altivar ATV IMC Drive Controller is being used on a local drive (a local drive is the drive on which the Altivar ATV IMC Drive Controller card is connected), the ATV template program is a good help for the users less familiar with the Altivar ATV IMC Drive Controller as well as a good support for advanced users to optimize the programming of an Altivar ATV IMC Drive Controller.

This template provides a program structure and the implementation of some functions such as the `MANDATORY_AT_EACH_CYCLE` function, access to acyclic data, and keypad parameter saves, all of which are necessary when programming an Altivar ATV IMC Drive Controller.

It is a best practice to use the ATV template to start an Altivar ATV IMC Drive Controller application.

Create a Project with the ATV Template

Use SoMachine Central to create a project with the ATV template.

Refer to New Project Assistant - Templates (see *SoMachine Central, User Guide*) for more information.

Overview of the ATV Template

Template Diagram

The ATV template is a structured program following the logic shown in this diagram:

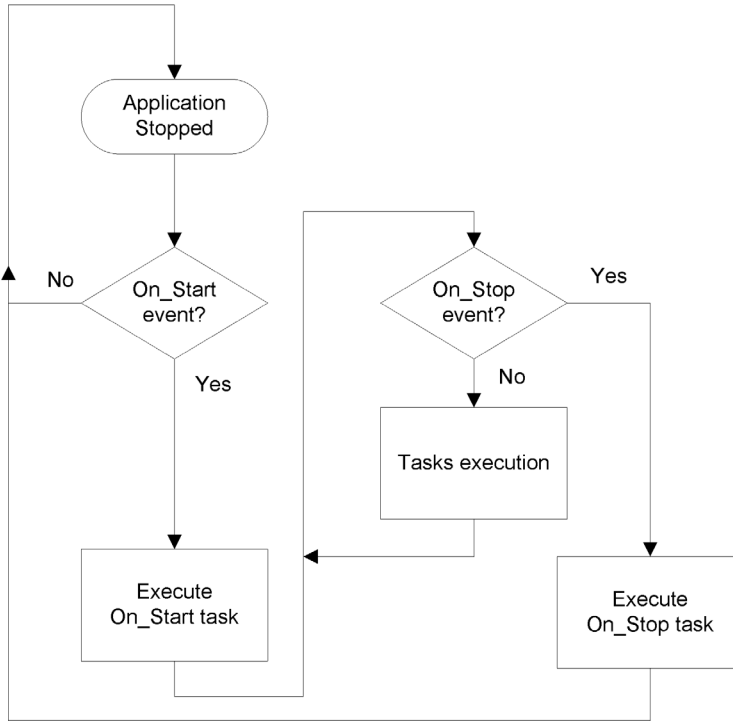

Tasks Description

The ATV_Template is structured around 5 tasks:

Start_task This task is executed with the On_Start event and executes the ATV_IMC_Start POU.

Stop_task This task is executed with the On_Stop event and executes the ATV_IMC_Stop POU.

Tasks execution The following 3 tasks are executed during this step with the following priority:

- 1- **Sync_task** This task is executed with the On_Sync event and executes the Application_SyncTask POU.
- 2- **Mast** This is a cyclic task; it is executed every 20 ms and executes the Application_MastTask POU.
- 3- **Freewheel_task** This is a freewheel task; it is executed in background and executes the PLC_PRG POU.

For more information about task and events, refer to the Task Types ([see page 31](#))

Program Organisation Unit (POU)

Overview

The ATV Template has several POUs that can be used to manage a local drive and execute the applications you may need.

POUs are displayed in the **Applications tree**.

POUs are organized in 2 different categories:

- The POUs executed directly because of a task
- The POUs executed by the PLC_PRG POU.

POUs Executed by a Task

The following POUs are executed with the occurrence of a task:

POU name	Description
ATV_IMC_Stop	This program is only called once. Program here actions to execute when the program stops, for example manage Fall back state of canopen device.
ATV_IMC_Start	This program is only called once. Program here actions to execute when the program starts. There are 2 optional functions prepared if required for your application. Remove the comment elements (* and *) to enable the functionality : <ul style="list-style-type: none"> ● Activate the fault datation (see <i>Altivar ATV IMC Drive Controller, ATV IMC UserLib Library Guide</i>) ● Read the switch (see <i>Altivar ATV IMC Drive Controller, ATV IMC UserLib Library Guide</i>)
Application_MastTask	This program is called every 20 ms, program here actions that don't affect the local drive.
Application_SyncTask	This program is called every 2 ms (by default), when fast drive control is required for your process, program here drive control commands with the Drive Control functions and Drive Functions (see <i>Altivar ATV IMC Drive Controller, ATV IMC UserLib Library Guide</i>).

POU name	Description
PLC_PRG	<p>This is the main application POU.</p> <p>This POU manages the application according to the status of the drive through the usage of the <code>MANDATORY_AT_EACH_CYCLE</code> (see <i>Altivar ATV IMC Drive Controller, ATV IMC UserLib Library Guide</i>) function.</p> <p>Several POU are executed here depending on the result of the <code>MANDATORY_AT_EACH_CYCLE</code> function block:</p> <ul style="list-style-type: none"> ● Drive_Stop ● Drive_Start ● Display_RestoreSavedParameters ● Application_Aperiodic Exchange ● Application_Main

POUs Executed During PLC_PRG

Depending on the result of the `MANDATORY_AT_EACH_CYCLE` function block, the following POU can be executed:

MANDATORY_AT_EACH_CYCLE result	POU executed	Description
bError =1	Drive_Stop	Execute in this program actions to be done when drive is not present or communication interruption.
xInitState =1	Drive_Start	<p>This program is executed when the drive is present but not initialized.</p> <p>You can generate aperiodic requests to configure the drive and get data from the drive when removing the comment elements in this program.</p> <p>NOTE: Update the value <code>wStateInitialization</code> in the case 3 of the <code>Drive_Start</code> POU if you want to use the aperiodic request.</p>
	Display_RestoreSavedParameters	<p>This POU is executed during the case 3 of the <code>Drive_Start</code> POU execution.</p> <p>In an ATV IMC application, the keypad allows to display parameters used during the execution of the application. This POU allows to restore the values of the Display Parameter (see page 79) which had been configured to be saved.</p>
xInitState =0	Application_Aperiodic Exchange	Use this POU to read and write the drive parameters with the <code>DriveParameterRead1</code> and <code>DriveParameterWrite1</code> functions.
	Application_Main	This POU should be used for your main application. The execution of this POU is done once the presences of the drive is confirmed and the initialization done.

 **WARNING**

UNINTENDED EQUIPMENT OPERATION

Only use the Drive Parameter function (see *Altivar ATV IMC Drive Controller, ATV IMC UserLib Library Guide*) in a POU linked to the freewheel task.

Failure to follow these instructions can result in death, serious injury, or equipment damage.

Chapter 4

Libraries

Automation Libraries

Introduction

Libraries provide functions, function blocks, data types, and global variables that can be used to develop your project.

The **Library Manager** of SoMachine provides information about the libraries included in your project and allows you to install new ones. For more information on the **Library Manager**, refer to the SoMachine Programming Guide.

ATV IMC Drive Controller Libraries

When you select a ATV IMC for your application, ATV IMC automatically loads the following libraries:

Library Name	Description
IoStandard	CmpIoMgr configuration types, ConfigAccess, Parameters, and help functions: manages the I/Os in the application.
Standard	Contains all functions and function blocks which are required matching IEC61131-3 as standard POUs for an IEC programming system. The standard POUs must be tied to the project (standard.library).
Util	Analog Monitors, BCD Conversions, Bit/Byte Functions, Controller Datatypes, Function Manipulators, Mathematical Functions, Signals.
ATV IMC SysLib	interface with the ATV 71 and 61 local drive
ATV IMC UserLib	interface with the ATV 71 and 61 local drive
ATV IMC HSC (<i>see Altivar ATV IMC Drive Controller, High Speed Counting, ATV IMC HSC Library Guide</i>)	Contains function blocks and variables to get information and send commands to the Fast Inputs/Outputs of the ATV IMC controller. These function blocks permit you to implement HSC (High Speed Counting) functions on the Fast Inputs/Outputs of the ATV IMC controller.
ATV IMC PLCSystem (<i>see Altivar ATV IMC Drive Controller, System Functions and Variables, ATV-IMC PLCSystem Library Guide</i>)	Contains functions and variables to get information and send commands to the controller system.

Chapter 5

Supported Standard Data Types

Supported Standard Data Types

Supported Standard Data Types

The controller supports the following IEC data types:

Data Type	Lower Limit	Upper Limit	Information Content
BOOL	False	True	1 Bit
BYTE	0	255	8 Bit
WORD	0	65,535	16 Bit
DWORD	0	4,294,967,295	32 Bit
LWORD	0	$2^{64}-1$	64 Bit
SINT	-128	127	8 Bit
USINT	0	255	8 Bit
INT	-32,768	32,767	16 Bit
UINT	0	65,535	16 Bit
DINT	-2,147,483,648	2,147,483,647	32 Bit
UDINT	0	4,294,967,295	32 Bit
LINT	-2^{63}	$2^{63}-1$	64 Bit
ULINT	0	$2^{64}-1$	64 Bit
REAL	1.175494351e-38	3.402823466e+38	32 Bit
LREAL	2.2250738585072014e-308	1.7976931348623158e+308	64 Bit
STRING	1 character	255 characters	1 character = 1 byte
WSTRING	1 character	255 characters	1 character = 1 word
TIME	-	-	32 Bit

For more information on ARRAY, LTIME, DATE, TIME, DATE_AND_TIME, and TIME_OF_DAY, refer to the SoMachine Programming Guide.

Chapter 6

Memory Mapping

Memory Organization

Introduction

This section provides the RAM (Random Access Memory) size with the different types of area for controllers and libraries.

ATV IMC Memory

The RAM size is more than 3 MBytes composed of 2 areas:

- 1024 Kbytes System Area for Operating System memory
- 2248 Kbytes Customer Area for dedicated application memory

This table shows the different types of memory areas with their sizes for the ATV IMC memory:

Area	Element	Size (Kbytes)
System Area 1024 Kbytes	Located Variables (%MW0...%MW65535)	128
	Reserved	896
Customer Area 2248 Kbytes	Variables (including Retain and Persistent variables, see table below)	2248 ⁽¹⁾
	Application	
	Libraries	
	Symbols	
⁽¹⁾ Size checked at build time and must not exceed the value indicated in the table.		

Retained and Persistent Variables	
64 Kbytes	Retain Variables ⁽²⁾
32 Kbytes	Persistent Variables
⁽²⁾ Not all the 64 Kbytes are available for the customer application because some libraries may use Retain Variables.	

Library Size

Library Name	Average Size	Comment
3S CANopenStack	86 Kbyte	Depends on the functions used. Each CANopen node increases the memory size of 11 Kbyte.

NOTE: The maximum number of CANopen nodes is 16.

Chapter 7

Tasks

Introduction

The **Task Configuration** node in the **Applications tree** allows you to define one or more tasks to control the execution of your application program.

The task types available are:

- Cyclic
- Freewheeling
- External event

This chapter begins with an explanation of these task types and provides information regarding the maximum number of tasks, the default task configuration, and task prioritization. In addition, this chapter introduces the system and task watchdog functions and explains its relationship to task execution.

What Is in This Chapter?

This chapter contains the following topics:

Topic	Page
Maximum Number of Tasks	28
Task Configuration Screen	29
Task Types	31
System and Task Watchdogs	33
Task Priorities	34
Default Task Configuration	35

Maximum Number of Tasks

Maximum Number of Tasks

The maximum number of tasks you can define for the ATV IMC are:

- Total number of tasks = 9
- Cyclic tasks = 3
- Freewheeling tasks = 1
- External Event tasks = 5

Special Considerations for Freewheeling

A Freewheeling task (*see page 32*) does not have a fixed duration. In Freewheeling mode, each task scan starts when the previous scan has been completed and after a period of system processing (30% of the total duration of the Freewheeling task). If the system processing period is reduced to less than 15% for more than 3 seconds due to other tasks interruptions, a system error is detected. For more information, refer to the System Watchdog (*see page 33*).

NOTE: You should not use a Freewheeling task in a multi-task application when some high priority and time-consuming tasks are running. Doing so runs the risk of provoking a task Watchdog Timeout. You should not assign CANopen to a freewheeling task. CANopen should be assigned to a cyclic task.

Task Configuration Screen

Screen Description

This screen allows you to configure the tasks. Double-click the task that you want to configure in the **Applications tree** to access this screen.

Each configuration task has its own parameters that are independent of the other tasks.

The **Configuration** window is composed of 4 parts:

The screenshot shows the MAST Configuration window with the following sections:

- Priority (0..31):** A text input field containing the value '1'.
- Type:** A dropdown menu set to 'Cyclic' and an 'Interval (e.g. t#200ms):' field containing '#20ms' with a unit dropdown set to 'ms'.
- Watchdog:** An 'Enable' checkbox that is checked, a 'Time (e.g. t#200ms):' field containing '100' with a unit dropdown set to 'ms', and a 'Sensitivity:' field containing '1'.
- Toolbar:** A row of icons for 'Add Call', 'Remove Call', 'Change Call', 'Move Up', 'Move Down', and 'Open POU'.
- Table:** A table with two columns: 'POU' and 'Comment'. The table is currently empty.

The table describes the fields of the **Configuration** screen:

Field Name	Definition
Priority	<p>Configure the priority of each task with a number from 0 to 31 (0 is the highest priority, 31 is the lowest).</p> <p>Only one task at a time can be running. The priority determines when the task will run:</p> <ul style="list-style-type: none"> ● a higher priority task will pre-empt a lower priority task ● tasks with same priority will run in turn (2 ms time-slice) <p>NOTE: Do not assign tasks with the same priority. If there are yet other tasks that attempt to pre-empt tasks with the same priority, the result could be indeterminate and unpredictable. For safety information, refer to Task Priorities (see page 34).</p>
Type	<p>These task types are available:</p> <ul style="list-style-type: none"> ● Cyclic (see page 31) ● External (see page 32) ● Freewheeling (see page 32)
Watchdog	<p>To configure the watchdog (see page 33), define these 2 parameters:</p> <ul style="list-style-type: none"> ● Time: enter the timeout before watchdog execution. ● Sensitivity: defines the number of expirations of the watchdog timer before the controller stops program execution and enters a HALT state (see page 39).
POUs	<p>The list of POUs (see SoMachine, Programming Guide) (Programming Organization Units) controlled by the task is defined in the task configuration window:</p> <ul style="list-style-type: none"> ● To add a POU linked to the task, use the command Add Call and select the POU in the Input Assistant editor. ● To remove a POU from the list, use the command Remove Call. ● To replace the currently selected POU of the list by another one, use the command Change Call. ● POUs are executed in the order shown in the list. To move the POUs in the list, select a POU and use the command Move Up or Move Down. <p>NOTE: You can create as many POUs as you want. An application with several small POUs, as opposed to one large POU, can improve the refresh time of the variables in online mode.</p>

Task Types

Introduction

The following section describes the various task types available for your program, along with a description of the task type characteristics.

Cyclic Task

A Cyclic task is assigned a fixed cycle time using the Interval setting in the Type section of Configuration subtab for that task. Each Cyclic task type executes as follows:

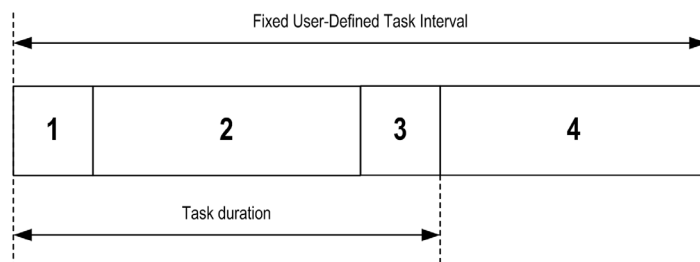

1. **Read Inputs:** The physical input states are written to the %I input memory variables and other system operations are executed.
2. **Task Processing:** The user code (POU, and so on) defined in the task is processed. The %Q output memory variables are updated according to your application program instructions but not yet written to the physical outputs during this operation.
3. **Write Outputs:** The %Q output memory variables are modified with any output forcing that has been defined; however, the writing of the physical outputs depends upon the type of output and instructions used.
For more information on defining the bus cycle task, refer to the SoMachine Programming Guide.
For more information on I/O behavior, refer to Controller States Detailed Description ([see page 45](#)).
4. **Remaining Interval time:** The controller firmware carries out system processing and any other lower priority tasks.

NOTE: If you define too short a period for a cyclic task, it will repeat immediately after the write of the outputs and without executing other lower priority tasks or any system processing. This will affect the execution of all tasks and cause the controller to exceed the system watchdog limits, generating a system watchdog exception.

NOTE: Get and set the interval of a Cyclic Task by application using the **GetCurrentTaskCycle** and **SetCurrentTaskCycle** function. (Refer to Toolbox Advance Library Guide for further details.)

Freewheeling Task

A Freewheeling task does not have a fixed duration. In Freewheeling mode, each task scan begins when the previous scan has been completed and after a short period of system processing. Each Freewheeling task type executes as follows:

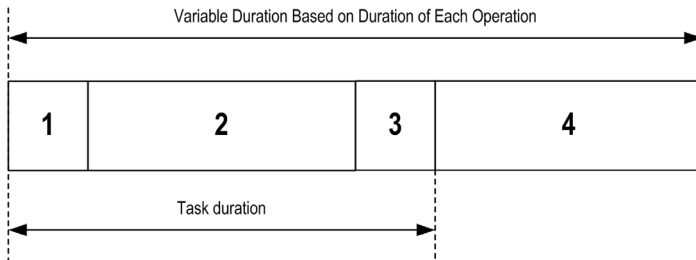

1. **Read Inputs:** The physical input states are written to the %I input memory variables and other system operations are executed.
2. **Task Processing:** The user code (POU, and so on) defined in the task is processed. The %Q output memory variables are updated according to your application program instructions but not yet written to the physical outputs during this operation.
3. **Write Outputs:** The %Q output memory variables are modified with any output forcing that has been defined; however, the writing of the physical outputs depends upon the type of output and instructions used.
For more information on defining the bus cycle task, refer to the SoMachine Programming Guide.
For more information on I/O behavior, refer to Controller States Detailed Description ([see page 45](#)).
4. **System Processing:** The controller firmware carries out system processing and any other lower priority tasks (for example: HTTP management, Ethernet management, parameters management).

External Event Task

This type of task is event-driven and is initiated by the detection of a hardware or hardware-related function event. It starts when the event occurs unless pre-empted by a higher priority task. In that case, the External Event task will start as dictated by the task priority assignments.

NOTE: It is not possible to assign more than one task to a single external event.

You can trigger a task associated to an external event through:

- A rising edge on a Fast input (`on_LI53` and `on_LI54`)
- The start/stop of the controller program (`on_Start` and `on_Stop`)
- An external event periodically produced by the local drive (`on_Sync`)

NOTE: You can configure the `on_Sync` period with the `SyncTaskPeriodSet` function (*see Altivar ATV IMC Drive Controller, ATV IMC UserLib Library Guide*) (default value is 2 ms).

System and Task Watchdogs

Introduction

Two types of watchdog functionality are implemented for the ATV IMC:

- **System Watchdogs:** These watchdogs are defined in and managed by the controller firmware. These are not configurable by the user.
- **Task Watchdogs:** Optional watchdogs that can be defined for each task. These are managed by your application program and are configurable in SoMachine.

System Watchdogs

Two system watchdogs are defined for the ATV IMC. They are managed by the controller firmware and are therefore sometimes referred to as hardware watchdogs in the SoMachine online help. When the system watchdog exceeds its threshold conditions, an error is detected.

The threshold conditions for the 2 system watchdogs are defined as follows:

- If all of the tasks require more than 85% of the processor resources for more than 3 seconds, a system error is detected. The controller enters the EMPTY state.
- If the lowest priority task of the system is not executed during an interval of 20 seconds, a system error is detected. The controller responds with an automatic reboot into the EMPTY state.

NOTE: System watchdogs are not configurable by the user.

Task Watchdogs

SoMachine allows you to configure an optional task watchdog for every task defined in your application program. (Task watchdogs are sometimes also referred to as software watchdogs or control timers in the SoMachine online help). When one of your defined task watchdogs reaches its threshold condition, an application error is detected and the controller enters the HALT state.

When defining a task watchdog, the following options are available:

- **Time:** This defines the allowable maximum execution time for a task. When a task takes longer than this, the controller will report a task watchdog exception.
- **Sensitivity:** The sensitivity field defines the number of task watchdog exceptions that must occur before the controller detects an application error.

To access the configuration of a task watchdog, double-click the **Task** in the **Applications tree**.

NOTE: For more information on watchdogs, refer to SoMachine Programming Guide.

Task Priorities

Task Priority Configuration

You can configure the priority of each Cyclic and on_LI5x tasks between 0 and 31 (0 is the highest priority and 31 is the lowest). Each task must have a unique priority.

Priority levels from the highest to lowest:

- On_SYNC task
- Cyclic task, on_LI53, on_LI54
- Freewheel task has the lowest priority.

NOTE: Changing the priority value of the On_SYNC and the Freewheel tasks will not be taken into account. Their priority is fixed as described above. Further, changing the priority of the cyclic task, on_LI5x above the On_SYNC or below the freewheel task will likewise have no effect.

WARNING

UNINTENDED EQUIPMENT OPERATION

Do not assign the same priority to different tasks.

Failure to follow these instructions can result in death, serious injury, or equipment damage.

Default Task Configuration

Default Task Configuration

The MAST task can be configured in Freewheeling or Cyclic mode. The MAST task is automatically created by default in Cyclic mode. Its preset priority is medium (15), its preset interval is 20 ms, and its task watchdog service is activated with a time of 100 ms and a sensitivity of 1. Refer to Task Priorities ([see page 34](#)) for more information on priority settings. Refer to System and Task Watchdogs ([see page 33](#)) for more information on watchdogs.

Designing an efficient application program is important in systems approaching the maximum number of tasks. In such an application, it can be difficult to keep the resource utilization below the system watchdog threshold. If priority reassignments alone are not sufficient to remain below the threshold, some lower priority tasks can be made to use fewer system resources if the SysTaskWaitSleep function is added to those tasks. For more information about this function, see the optional SysTask library of the system / SysLibs category of libraries.

NOTE: Do not delete or change the name of the MAST task. If you do so, SoMachine detects an error when you attempt to build the application, and you will not be able to download it to the controller.

Chapter 8

Controller States and Behaviors

Introduction

This chapter provides you with information on controller states, state transitions, and behaviors in response to system events. It begins with a detailed controller state diagram and a description of each state. It then defines the relationship of output states to controller states before explaining the commands and events that result in state transitions. It concludes with information about Remanent variables and the effect of SoMachine task programming options on the behavior of your system.

What Is in This Chapter?

This chapter contains the following sections:

Section	Topic	Page
8.1	Controller State Diagram	38
8.2	Controller States Description	45
8.3	State Transitions and System Events	49

Section 8.1

Controller State Diagram

Controller State Diagram

Controller State Diagram

The following diagram describes the controller operating mode:

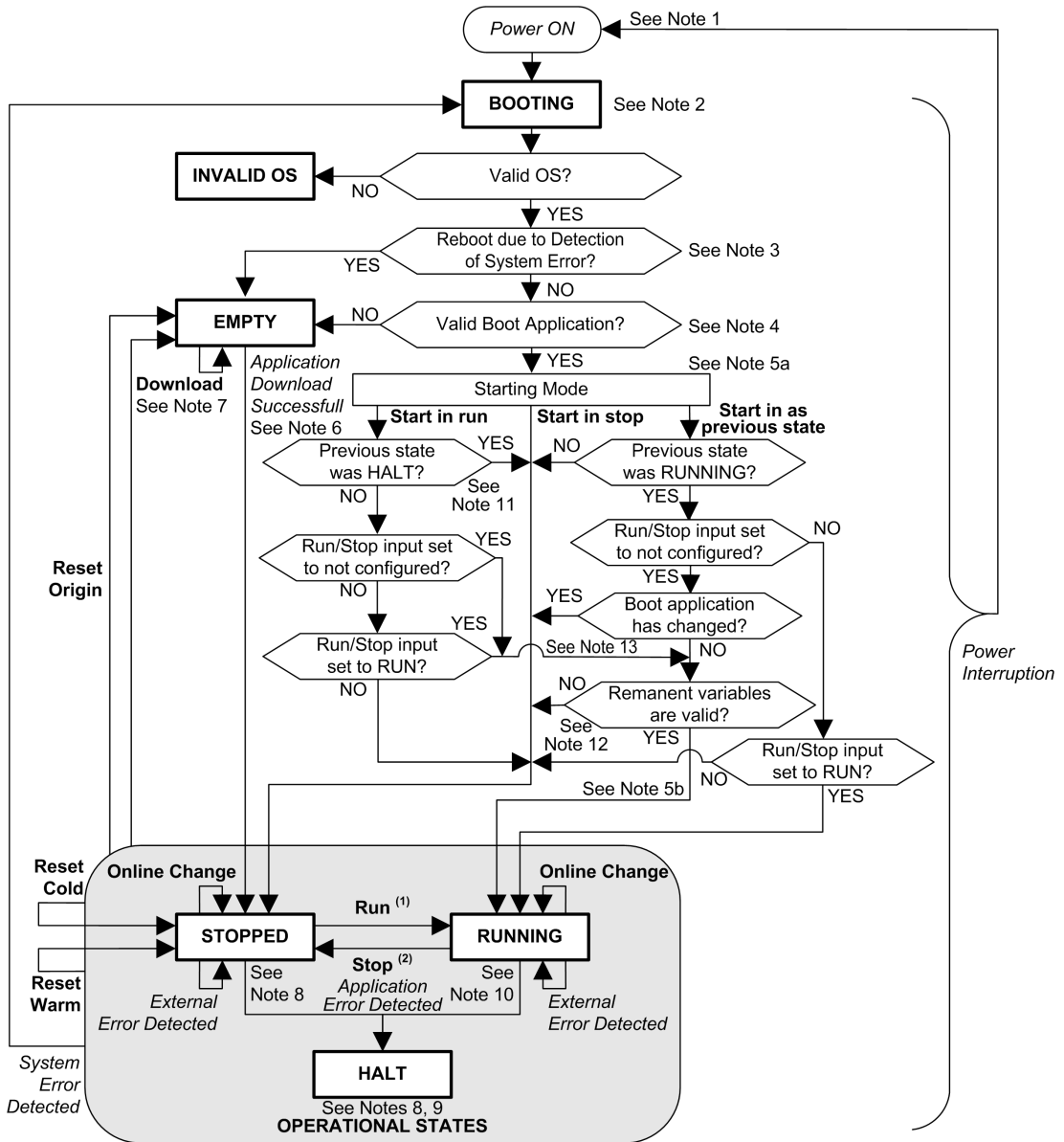

Legend:

- Controller states are indicated in **ALL-CAPS BOLD**
- User and application commands are indicated in **Bold**

- System events are indicated in *Italics*
 - Decisions, decision results and general information are indicated in normal text
- (1) For details on STOPPED to RUNNING state transition, refer to Run Command ([see page 53](#)).
- (2) For details on RUNNING to STOPPED state transition, refer to Stop Command ([see page 53](#)).

Note 1

The Power Cycle (Power Interruption followed by a Power ON) deletes all output forcing settings. Refer to Controller State and Output Behavior ([see page 50](#)) for further details.

Note 2

There is a 1-2 second delay between entering the BOOTING state and the LED indication of this state. The boot process can take up to 5 seconds under normal conditions. The outputs will assume their initialization states.

Note 3

In some cases, when a system error is detected, it will cause the controller to automatically reboot into the EMPTY state as if no Boot application were present in the Flash memory. However, the Boot application is not actually deleted from the Flash memory.

Note 4

The application is loaded into RAM after verification of a valid Boot application.

During the load of the boot application, a Check context test occurs to assure that the Remanent variables are valid. If the Check context test is invalid, the boot application will load but the controller will assume STOPPED state ([see page 55](#)).

Note 5a

The **Starting Mode** is set in the **PLC settings** tab of the **Controller Device Editor**.

Note 5b

When a power interruption occurs, the controller reassumes the state before the power interruption. However, depending on the source of power of the ATV IMC drive controller and whether you configured the Run/Stop input, the ATV IMC drive controller may interpret the loss of power to the Run/Stop input as a Stop command. In this case, when power returns the controller will assume the STOPPED state.

Note 6

During a successful application download, the following events occur:

- The application is loaded directly into RAM.
- By default, the Boot application is created and saved into the Flash memory.

Note 7

The default behavior after downloading an application program is for the controller to enter the STOPPED state irrespective of the Run/Stop input setting or the last controller state before the download.

However, there are two important considerations in this regard:

Online Change: An online change (partial download) initiated while the controller is in the RUNNING state returns the controller to the RUNNING state if successful and provided the Run/Stop input is configured and set to Run. Before using the **Login with online change** option, test the changes to your application program in a virtual or non-production environment and confirm that the controller and attached equipment assume their expected conditions in the RUNNING state.

 **WARNING****UNINTENDED EQUIPMENT OPERATION**

Always verify that online changes to a RUNNING application program operate as expected before downloading them to controllers.

Failure to follow these instructions can result in death, serious injury, or equipment damage.

NOTE: Online changes to your program are not automatically written to the Boot application, and will be overwritten by the existing Boot application at the next reboot. If you wish your changes to persist through a reboot, manually update the Boot application by selecting **Create boot application** in the Online menu (the controller must be in the STOPPED state to achieve this operation).

Multiple Download: SoMachine has a feature that allows you to perform a full application download to multiple targets on your network or fieldbus. One of the default options when you select the **Multiple Download...** command is the **Start all applications after download or online change** option, which restarts all download targets in the RUNNING state, provided their respective Run/Stop inputs are commanding the RUNNING state, but irrespective of their last controller state before the multiple download was initiated. Deselect this option if you do not want all targeted controllers to restart in the RUNNING state. In addition, before using the **Multiple Download** option, test the changes to your application program in a virtual or non-production environment and confirm that the targeted controllers and attached equipment assume their expected conditions in the RUNNING state.

WARNING

UNINTENDED EQUIPMENT OPERATION

Always verify that your application program will operate as expected for all targeted controllers and equipment before issuing the "**Multiple Download...**" command with the "**Start all applications after download or online change**" option selected.

Failure to follow these instructions can result in death, serious injury, or equipment damage.

NOTE: During a multiple download, unlike a normal download, SoMachine does not offer the option to create a Boot application. You can manually create a Boot application at any time by selecting **Create boot application** in the **Online menu** on all targeted controllers (the controller must be in the STOPPED state for this operation).

Note 8

The SoMachine software platform allows many powerful options for managing task execution and output conditions while the controller is in the STOPPED or HALT states. Refer to Controller States Description ([see page 45](#)) for further details.

Note 9

To exit the HALT state it is necessary to issue one of the Reset commands (Reset Warm, Reset Cold, Reset Origin), download an application or cycle power.

In case of non recoverable event (hardware watchdog or internal detected error), a cycle power is mandatory.

Note 10

The RUNNING state has two exception conditions.

They are:

- RUNNING with External Detected Error: this exception condition is indicated by the MS Status LED, which displays solid green with 1 red flash. You may exit this state by clearing the external detected error. No controller commands are required.
- RUNNING with Breakpoint: this exception condition is indicated by the MS Status LED, which displays 3 green flashes. Refer to Controller States Description ([see page 45](#)) for further details.

Note 11

When Starting Mode is set to Start in run and if the Run/Stop input is not configured, the controller will reboot in STOPPED state. A second reboot will be necessary to set the controller in RUNNING state.

Note 12

Remanent variables can be invalid if battery is not present for example.

Note 13

The boot application can be different from the application loaded. It can happen when the boot application was downloaded through USB Key, FTP or File Transfer or when an online change was performed without creating the boot application.

Section 8.2

Controller States Description

Controller States Description

Introduction

This section provides a detailed description of the controller states.

⚠ WARNING
<p>UNINTENDED EQUIPMENT OPERATION</p> <ul style="list-style-type: none"> • Never assume that your controller is in a certain controller state before commanding a change of state, configuring your controller options, uploading a program, or modifying the physical configuration of the controller and its connected equipment. • Before performing any of these operations, consider the effect on all connected equipment. • Before acting on a controller, always positively confirm the controller state by viewing its LEDs, confirming the condition of the Run/Stop input, verifying the presence of output forcing, and reviewing the controller status information via SoMachine.⁽¹⁾ <p>Failure to follow these instructions can result in death, serious injury, or equipment damage.</p>

⁽¹⁾ The controller states can be read in the PLC_R.i_wStatus system variable of the ATV IMC PLCSystem (see *Altivar ATV IMC Drive Controller, System Functions and Variables, ATV-IMC PLCSystem Library Guide*)

Controller States Table

The following table describes the controller states:

Controller State	Description	RUN/MS LED
BOOTING	The controller executes the boot firmware and its own internal self-tests. It then verifies the checksum of the firmware and user applications. It does not execute the application nor does it communicate.	Green/red flashing
BOOTING after detection of a <i>System Error</i>	This state is the same as the normal BOOTING state except that a flag is set to make it appear as if no Boot application is present and the LED indications are different.	Rapid red flashing

Controller State	Description	RUN/MS LED
INVALID_OS	There is not a valid firmware file present in the Flash memory. The controller does not execute the application. Communication is only possible through the USB host port, and then only for uploading a valid OS. Refer to Upgrading ATV IMC Controller Firmware (see page 129).	Red flashing
EMPTY	There is no or an invalid application.	Single green flash
EMPTY after detection of a <i>System Error</i>	This state is the same as the normal EMPTY state except that a flag is set to make it appear as if no Boot Application is present (no Application is loaded) and the LED indications are different.	Red
RUNNING	The controller is executing a valid application.	Green
RUNNING with Breakpoint	This state is the same as the RUNNING state with the following exceptions: <ul style="list-style-type: none"> • The task-processing portion of the program does not resume until the breakpoint is cleared. • The LED indications are different. For more information on breakpoint management, refer to the SoMachine Programming Guide.	3 green flashes
RUNNING with detection of an <i>External Error</i>	This state is the same as the normal RUNNING state except the LED indications are different.	Green / single red flash
STOPPED	The controller has a valid application that is stopped. See Details of the STOPPED State (see page 47) for an explanation of the behavior of outputs and field buses in this state.	Green flashing
STOPPED with detection of an <i>External Error</i>	This state is the same as the normal STOPPED state except the LED indications are different.	Green flashing / single red flash
HALT	The controller stops executing the application because it has detected an Application Error. This description is the same as for the STOPPED state with the following exceptions: <ul style="list-style-type: none"> • The task responsible for the Application Detected Error always behaves as if the Update IO while in stop option was not selected. All other tasks follow the actual setting. • The LED indications are different. 	Single red flash

Details of the STOPPED State

The following statements are true for the STOPPED state:

- Ethernet, Serial (Modbus, ASCII, and so on), and USB communication services remain operational and commands written by these services can continue to affect the application, the controller state, and the memory variables.
- All outputs initially assume their configured default state (**Keep current values** or **Set all outputs to default**) or the state dictated by output forcing if used. The subsequent state of the outputs depends on the value of the **Update IO while in stop** setting and on commands received from remote devices.

Task and I/O Behavior When Update IO While In Stop Is Selected

When the **Update IO while in stop** setting is selected:

- The Read Inputs operation continues normally. The physical inputs are read and then written to the %I input memory variables.
- The Task Processing operation is not executed.
- The Write Outputs operation continues. The %Q output memory variables are updated to reflect either the **Keep current values** configuration or the **Set all outputs to default** configuration, adjusted for any output forcing, and then written to the physical outputs.

NOTE: Expert functions continue to operate. For example, a counter will continue to count.

However, these Expert functions do not affect the state of the outputs. The outputs of Expert I/O conform to the behavior stated here.

NOTE: Commands received by Ethernet, Serial, USB, and CAN communications can continue to write to the memory variables. Changes to the %Q output memory variables are written to the physical outputs.

CAN Behavior When Update IO While In Stop Is Selected

The following is true for the CAN buses when the **Update IO while in stop** setting is selected:

- The CAN bus remains fully operational. Devices on the CAN bus continue to perceive the presence of a functional CAN Master.
- TPDO and RPDO continue to be exchanged.
- The optional SDO, if configured, continue to be exchanged.
- The Heartbeat and Node Guarding functions, if configured, continue to operate.
- If the **Behaviour for outputs in Stop** field is set to **Keep current values**, the TPDOs continue to be issued with the last actual values.
- If the **Behaviour for outputs in Stop** field is **Set all outputs to default** the last actual values are updated to the default values and subsequent TPDOs are issued with these default values.

Task and I/O Behavior When Update IO While In Stop Is Not Selected

When the **Update IO while in stop** setting is not selected, the controller sets the I/O to either the **Keep current values** or **Set all outputs to default** condition (as adjusted for output forcing if used). After this, the following becomes true:

- The Read Inputs operation ceases. The %I input memory variables are frozen at their last values.
- The Task Processing operation is not executed.
- The Write Outputs operation ceases. The %Q output memory variables can be updated via the Ethernet, Serial, and USB connections. However, the physical outputs are unaffected and retain the state specified by the configuration options.

NOTE: Expert functions cease operating. For example, a counter will be stopped.

CAN Behavior When Update IO While In Stop Is Not Selected

The following is true for the CAN buses when the **Update IO while in stop** setting is not selected:

- The CAN Master ceases communications. Devices on the CAN bus assume their configured fallback states.
- TPDO and RPDO exchanges cease.
- Optional SDO, if configured, exchanges cease.
- The Heartbeat and Node Guarding functions, if configured, stop.
- The current or default values, as appropriate, are written to the TPDOs and sent once before stopping the CAN Master.

Section 8.3

State Transitions and System Events

Overview

This section begins with an explanation of the output states possible for the controller. It then presents the system commands used to transition between controller states and the system events that can also affect these states. It concludes with an explanation of the Remanent variables, and the circumstances under which different variables and data types are retained through state transitions.

What Is in This Section?

This section contains the following topics:

Topic	Page
Controller States and Output Behavior	50
Commanding State Transitions	53
Error Detection, Types, and Management	58
Remanent Variables	60

Controller States and Output Behavior

Introduction

The ATV IMC defines output behavior in response to commands and system events in a way that allows for greater flexibility. An understanding of this behavior is necessary before discussing the commands and events that affect controller states. For example, typical controllers define only 2 options for output behavior in stop: fallback to default value or keep current value.

The possible output behaviors and the controller states to which they apply are:

- managed by **Application Program**
- keep **Current Values**
- set All **Outputs to Default**
- hardware **Initialization Values**
- software **Initialization Values**
- **Output Forcing**

Managed by Application Program

Your application program manages outputs normally. This applies in the RUNNING and RUNNING with External Error detected states.

Keep Current Values

Select this option by choosing **Keep current values** in the **Behavior for outputs in Stop** drop-down menu of the **PLC settings** subtab of the **Controller Editor**. To access the Controller Editor, right-click on the controller in the device tree and select **Edit Object**.

This output behavior applies in the STOPPED and HALT controller states. Outputs are set to and maintained in their current state, although the details of the output behavior vary greatly depending on the setting of the **Update I/O while in stop** option and the actions commanded via configured fieldbuses. Refer to Controller States Description ([see page 45](#)) for more details on these variations.

Set All Outputs to Default

Select this option by choosing **Set all outputs to default** in the **Behavior for outputs in Stop** drop-down menu of the **PLC settings** subtab of the **Controller Editor**. To access the **Controller Editor**, right-click on the controller in the device tree and select **Edit Object**.

This output behavior applies when the application is going from RUN state to STOPPED state or if the application is going from RUN state to HALT state. Outputs are set to and maintained in their current state, although the details of the output behavior vary greatly depending on the setting of the **Update I/O while in stop** option and the actions commanded via configured fieldbuses. Refer to Controller States Description ([see page 45](#)) for more details on these variations.

Hardware Initialization Values

This output state applies in the BOOTING, EMPTY (following power cycle with no boot application or after the detection of a system error), and INVALID_OS states.

In the initialization state, analog, transistor, and relay outputs assume the following values:

- For an analog output: Z (high impedance)
- For a fast transistor output: Z (high impedance)
- For a regular transistor output: 0 Vdc
- For a relay output: Open

Software Initialization Values

This output state applies when downloading or when resetting the application. It applies at the end of the download or at the end of a reset warm or cold.

The software **Initialization Values** are the initialization values of outputs images (%I, %Q, or variables mapped on %I or %Q).

By default, they are set to 0 but it is possible to map the I/O in a GVL and assign to the outputs a value different from 0.

Output Forcing

The controller allows you to force the state of selected outputs to a defined value for the purposes of system testing, commissioning, and maintenance.

You are only able to force the value of an output while your controller is connected to SoMachine.

To do so, use the **Force values** command in the **Debug** menu.

Output forcing overrides all other commands to an output irrespective of the task programming that is being executed.

When you logout of SoMachine when output forcing has been defined, you are presented with the option to retain output forcing settings. If you select this option, the output forcing continues to control the state of the selected outputs until you download an application or use one of the Reset commands.

When the option **Update I/O while in stop**, if supported by your controller, is checked (default state), the forced outputs keep the forcing value even when the logic controller is in STOP.

Output Forcing Considerations

The output you wish to force must be contained in a task that is currently being executed by the controller. Forcing outputs in unexecuted tasks, or in tasks whose execution is delayed either by priorities or events will have no effect on the output. However, once the task that had been delayed is executed, the forcing will take effect at that time.

Depending on task execution, the forcing could impact your application in ways that may not be obvious to you. For example, an event task could turn on an output. Later, you may attempt to turn off that output but the event is not being triggered at the time. This would have the effect of the forcing being apparently ignored. Further, at a later time, the event could trigger the task at which point the forcing would take effect.

WARNING

UNINTENDED EQUIPMENT OPERATION

- You must have a thorough understanding of how forcing will affect the outputs relative to the tasks being executed.
- Do not attempt to force I/O that is contained in tasks that you are not certain will be executed in a timely manner, unless your intent is for the forcing to take affect at the next execution of the task whenever that may be.
- If you force an output and there is no apparent affect on the physical output, do not exit SoMachine without removing the forcing.

Failure to follow these instructions can result in death, serious injury, or equipment damage.

Commanding State Transitions

Run Command

Effect: Commands a transition to the RUNNING controller state.

Starting Conditions: BOOTING or STOPPED state.

Methods for Issuing a Run Command:

- Run/Stop Input: If configured, command a rising edge to the Run/Stop input (assuming the Run/Stop switch is in the RUN position). Set the Run/Stop to 1 for all of the subsequent options to be effective.
Refer to Run/Stop Input (*see page 68*) for more information.
- SoMachine Online Menu: Select the **Start** command.
- **Login with online change** option: An online change (partial download) initiated while the controller is in the RUNNING state returns the controller to the RUNNING state if successful.
- **Multiple Download** Command: sets the controllers into the RUNNING state if the **Start all applications after download or online change** option is selected, irrespective of whether the targeted controllers were initially in the RUNNING, STOPPED, HALT, or EMPTY state.
- The controller is restarted into the RUNNING state automatically under certain conditions.

Refer to Controller State Diagram (*see page 39*) for further details.

Stop Command

Effect: Commands a transition to the STOPPED controller state.

Starting Conditions: BOOTING, EMPTY, or RUNNING state.

Methods for Issuing a Stop Command:

- Run/Stop Input: If configured, command a value of 0 to the Run/Stop input. Refer to Run/Stop Input (*see page 68*) for more information.
- SoMachine Online Menu: Select the **Stop** command.
- **Login with online change** option: An online change (partial download) initiated while the controller is in the STOPPED state returns the controller to the STOPPED state if successful.
- **Download** Command: implicitly sets the controller into the STOPPED state.
- **Multiple Download** Command: sets the controllers into the STOPPED state if the **Start all applications after download or online change** option is not selected, irrespective of whether the targeted controllers were initially in the RUNNING, STOPPED, HALT, or EMPTY state.
- The controller is restarted into the STOPPED state automatically under certain conditions.

Refer to Controller State Diagram (*see page 39*) for further details.

Reset Warm

Effect: Resets all variables, except for the remanent variables, to their default values. Places the controller into the STOPPED state.

Starting Conditions: RUNNING, STOPPED, or HALT states.

Methods for Issuing a Reset Warm Command:

- SoMachine Online Menu: Select the **Reset warm** command.
- By an internal call by the application using the PLC_W. q_wPLCControl and PLC_W. q_uiOpenPLCControl system variables of the ATV IMC PLCSystem library (see *Altivar ATV IMC Drive Controller, System Functions and Variables, ATV-IMC PLCSystem Library Guide*).

Effects of the Reset Warm Command:

1. The application stops.
2. Forcing is erased.
3. Diagnostic indications for detected errors are reset.
4. The values of the retain variables are maintained.
5. The values of the retain-persistent variables are maintained.
6. All non-located and non-remanent variables are reset to their initialization values.
7. The values of the %MW registers are maintained.
8. All fieldbus communications are stopped and then restarted after the reset is complete.
9. All I/O are briefly reset to their initialization values and then to their user-configured default values.

For details on variables, refer to Remanent Variables (see page 60).

Reset Cold

Effect: Resets all variables, except for the retain-persistent type of remanent variables, to their initialization values. Places the controller into the STOPPED state.

Starting Conditions: RUNNING, STOPPED, or HALT states.

Methods for Issuing a Reset Cold Command:

- SoMachine Online Menu: Select the **Reset cold** command.
- By an internal call by the application using the PLC_W. q_wPLCControl and PLC_W. q_uiOpenPLCControl system variables of the ATV IMC PLCSystem library (see *Altivar ATV IMC Drive Controller, System Functions and Variables, ATV-IMC PLCSystem Library Guide*).

Effects of the Reset Cold Command:

1. The application stops.
2. Forcing is erased.
3. Diagnostic indications for detected errors are reset.
4. The values of the retain variables are reset to their initialization value.
5. The values of the retain-persistent variables are maintained.
6. All non-located and non-remanent variables are reset to their initialization values.
7. The values of the %MW registers are maintained.
8. All fieldbus communications are stopped and then restarted after the reset is complete.
9. All I/O are briefly reset to their initialization values and then to their user-configured default values.

For details on variables, refer to Remanent Variables (see page 60).

Reset Origin

Effect: Resets all variables, including the remanent variables, to their initialization values. Erases all user files on the controller. Places the controller into the EMPTY state.

Starting Conditions: RUNNING, STOPPED, or HALT states.

Methods for Issuing a Reset Origin Command:

- SoMachine Online Menu: Select the **Reset origin** command.

Effects of the Reset Origin Command:

1. The application stops.
2. Forcing is erased.
3. All user files (Boot application, data logging) are erased.
4. Diagnostic indications for detected errors are reset.
5. The values of the retain variables are reset.
6. The values of the retain-persistent variables are reset.
7. All non-located and non-remanent variables are reset.
8. The values of the first 500 %MW registers are maintained.
9. All fieldbus communications are stopped.
10. All I/O are reset to their initialization values.

For details on variables, refer to Remanent Variables ([see page 60](#)).

Reboot

Effect: Commands a reboot of the controller.

Starting Conditions: Any state.

Methods for Issuing the Reboot Command:

- Power cycle

Effects of the Reboot:

1. The state of the controller depends on a number of conditions:
 - a. The controller state will be RUNNING if:

The Reboot was provoked by a power cycle and:

 - the **Starting Mode** is set to **Start in run**, and if the Run/Stop input is not configured, and if the controller was not in HALT state before the power cycle, and if the remanent variables are valid.
 - the **Starting Mode** is set to **Start in run**, and if the Run/Stop input is configured and set to RUN, and if the controller was not in HALT state before the power cycle, and if the remanent variables are valid.
 - the **Starting Mode** is set to **Start in as previous state**, and Controller state was RUNNING before the power cycle, and if the Run/Stop input is set to not configured and the boot application has not changed and the remanent variables are valid.
 - the **Starting Mode** is set to **Start in as previous state**, and Controller state was RUNNING before the power cycle, and if the Run/Stop input is configured and is set to RUN.
 - b. The controller state will be STOPPED if:

The Reboot was provoked by a Power cycle and:

 - the **Starting Mode** is set to **Start in stop**.

- the **Starting Mode** is set to **Start in as previous state** and the controller state was not RUNNING before the power cycle.
 - the **Starting Mode** is set to **Start in as previous state** and the controller state was RUNNING before the power cycle, and if the Run/Stop input is set to not configured, and if the boot application has changed.
 - the **Starting Mode** is set to **Start in as previous state** and the controller state was RUNNING before the power cycle, and if the Run/Stop input is set to not configured, and if the boot application has not changed, and if the remanent variables are not valid.
 - the **Starting Mode** is set to **Start in as previous state** and the controller state was RUNNING before the power cycle, and if the Run/Stop input is configured and is set to STOP.
 - the **Starting Mode** is set to **Start in run** and if the controller state was HALT before the power cycle.
 - the **Starting Mode** is set to **Start in run**, and if the controller state was not HALT before the power cycle, and if the Run/Stop input is configured and is set to STOP.
- c. The controller state will be EMPTY if:
- There is no boot application or the boot application is invalid, or
 - The reboot was provoked by specific detected System Errors.
- d. The controller state will be INVALID_OS if there is no valid firmware.
2. Forcing is maintained if the boot application is loaded successfully. If not, forcing is erased.
 3. Diagnostic indications for detected errors are reset.
 4. The values of the retain variables are restored if saved context is valid.
 5. The values of the retain-persistent variables are restored if saved context is valid.
 6. All non-located and non-remanent variables are reset to their initialization values.
 7. The values of the $\%MW$ registers are reset to 0.
 8. All fieldbus communications are stopped and restarted after the boot application is loaded successfully.
 9. All I/O are reset to their initialization values and then to their user-configured default values if the controller assumes a STOPPED state after the reboot.

For details on variables, refer to Remanent Variables ([see page 60](#)).

NOTE: The Check context test concludes that the context is valid when the application and the remanent variables are the same as defined in the Boot application.

NOTE: If you provide power to the Run/Stop input from the same source as the controller, the loss of power to this input will be detected immediately, and the controller will behave as if a STOP command was received. Therefore, if you provide power to the controller and the Run/Stop input from the same source, your controller will normally reboot into the STOPPED state after a power interruption when **Starting Mode** is set to **Start in as previous state**.

NOTE: If you make an online change to your application program while your controller is in the RUNNING or STOPPED state but do not manually update your Boot application, the controller will detect a difference in context at the next reboot, the remanent variables will be reset as per a Reset cold command, and the controller will enter the STOPPED state.

Download Application

Effect: Loads your application executable into the RAM memory. Optionally, creates a Boot application in the Flash memory.

Starting Conditions: RUNNING, STOPPED, HALT, and EMPTY states.

Methods for Issuing the Download Application Command:

- SoMachine:
 - 2 options exist for downloading a full application:
 - Download command.
 - Multiple Download command.

For important information on the application download commands, refer to Controller State Diagram ([see page 39](#)).

NOTE: It is possible to download the boot application but it will not start.

Effects of the SoMachine Download Command:

1. The existing application stops and then is erased.
2. If valid, the new application is loaded and the controller assumes a STOPPED state.
3. Forcing is erased.
4. Diagnostic indications for detected errors are reset.
5. The values of the retain variables are reset to their initialization values.
6. The values of any existing retain-persistent variables are maintained.
7. All non-located and non-remanent variables are reset to their initialization values.
8. The values of the $\%MW$ registers are reset to 0.
9. All fieldbus communications are stopped and then any configured fieldbus of the new application is started after the download is complete.
10. All I/O are reset to their initialization values and then set to the new user-configured default values after the download is complete.

For details on variables, refer to Remanent Variables ([see page 60](#)).

Error Detection, Types, and Management

Detected Error Management

The controller manages 3 types of detected errors:

- external detected errors
- application detected errors
- system detected errors

This table describes the types of errors that may be detected:

Type of Error Detected	Description	Resulting Controller State
External Error Detected	<p>External errors are detected by the system while RUNNING or STOPPED but do not affect the ongoing controller state. An external error is detected in the following cases:</p> <ul style="list-style-type: none"> ● A connected device reports a detected error to the controller. ● The controller detects an error with an external device whether it reports a detected error, for example when the external device is communicating but not properly configured for use with the controller. ● The controller detects an error with the state of an output. ● The controller detects a communication interruption with a device. ● The controller is configured for a module that is not present or not detected. ● The boot application in Flash memory is not the same as the one in RAM. <p>Examples:</p> <ul style="list-style-type: none"> ● output short circuit ● missing expansion module ● communication interruption ● and so on. 	<p>RUNNING with External Error Detected Or STOPPED with External Error Detected</p>
Application Error Detected	<p>An application error is detected when improper programming is encountered or when a task watchdog threshold is exceeded.</p> <p>Examples:</p> <ul style="list-style-type: none"> ● task (software) watchdog exception ● execution of an unknown function ● 80% task overload ● and so on. 	<p>HALT</p>

Type of Error Detected	Description	Resulting Controller State
System Error Detected	<p>A system error is detected when the controller enters a condition that cannot be managed during runtime. Most such conditions result from firmware or hardware exceptions, but there are some cases when incorrect programming can result in the detection of a system error, for example, when attempting to write to memory that was reserved during runtime.</p> <p>Examples:</p> <ul style="list-style-type: none"> ● system (hardware) watchdog overflow ● exceeding the defined size of an array ● and so on. <p>NOTE: There are some system detected errors that can be managed by runtime and are therefore treated like application detected errors.</p>	BOOTING → EMPTY

NOTE: Refer to the *ATV IMC PLCSystem Library Guide* (see *Altivar ATV IMC Drive Controller, System Functions and Variables, ATV-IMC PLCSystem Library Guide*) for more detailed information on diagnostics.

Remanent Variables

Overview

Remanent variables retain their values in the event of power outages, reboots, resets, and application program downloads. There are multiple types of remanent variables, declared individually as "retain" or "persistent", or in combination as "retain-persistent".

NOTE: For this controller, variables declared as persistent have the same behavior as variables declared as retain-persistent.

This table describes the behavior of remanent variables in each case:

Action	VAR	VAR RETAIN	VAR GLOBAL PERSISTENT RETAIN
Online change to application program	X	X	X
Stop	X	X	X
Power cycle	-	X	X
Reset warm	-	X	X
Reset cold	-	-	X
Reset origin	-	-	-
Download of application program	-	-	X
X The value is maintained - The value is re initialized			

Adding Retain Persistent Variables

Declare retain persistent (**VAR GLOBAL PERSISTENT RETAIN**) symbols in the **PersistentVars** window:

Step	Action
1	Select the Application node in the Applications tree .
2	Click  .
3	Choose Add other objects → Persistent variables
4	Click Add . Result: The PersistentVars window is displayed.

Chapter 9

Controller Device Editor

Introduction

This chapter describes how to configure the controller.

What Is in This Chapter?

This chapter contains the following topics:

Topic	Page
Controller Parameters	62
Controller Selection	64
Services	66

Controller Parameters

Controller Parameters

To open the device editor, double-click **MyController** in the **Devices tree**:

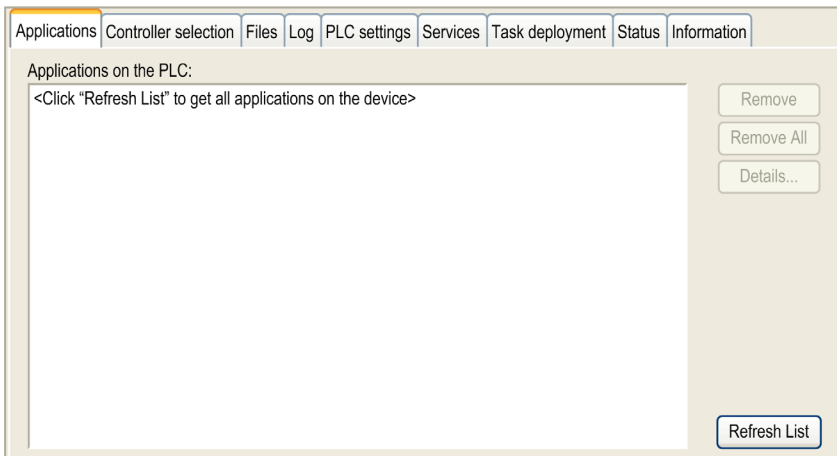

Tab Descriptions

Tab	Description	Restriction
Applications	Shows the application currently running on the controller and allows removing the application from the controller.	Online mode only
Controller selection <i>(see page 64)</i>	Manages the connection from PC to the controller: <ul style="list-style-type: none"> ● Lets you find a controller in a network. ● Shows the list of available controllers, so you can connect to the selected controller and manage the application inside the controller. ● Lets you physically identify the controller from the device editor. ● Lets you change the communication settings of the controller. 	Online mode only
Files	File management between the PC and the controller.	Online mode only
Log	Lets you view the events that have been logged on the runtime system including: <ul style="list-style-type: none"> ● Events at system start or shutdown (loaded components and their versions) ● Application download and boot project download ● Customer entries ● Log entries of I/O drivers ● Log entries of the Data Server 	–

Tab	Description	Restriction
PLC settings	Configuration of: <ul style="list-style-type: none">● application name● I/O behavior in stop● bus cycle options	–
Services <i>(see page 66)</i>	Lets you configure the online services of the controller (RTC, device identification).	Online mode only
Task deployment	Displays a list of I/Os and their assignments to tasks.	After compilation only
Status	Displays device-specific status and diagnostic messages.	–
Information	Displays general information about the device (name, description, provider, version, image).	–

Controller Selection

Introduction

This tab allows you to manage the connection from the PC to the controller:

- Lets you find a controller in a network.
- Shows the list of available controllers, so you can connect to the selected controller and manage the application inside the controller.
- Lets you physically identify the controller from the device editor.
- Lets you change the communication settings of the controller.

Process Communication Settings

The **Process communication settings** window lets you change the Ethernet communication settings. To do so, click **Controller selection** tab. The list of controllers available in the network appears. Select and right-click the required row and click **Process communication settings ...** in the context menu.

The **Process communication settings** window appears as shown below:

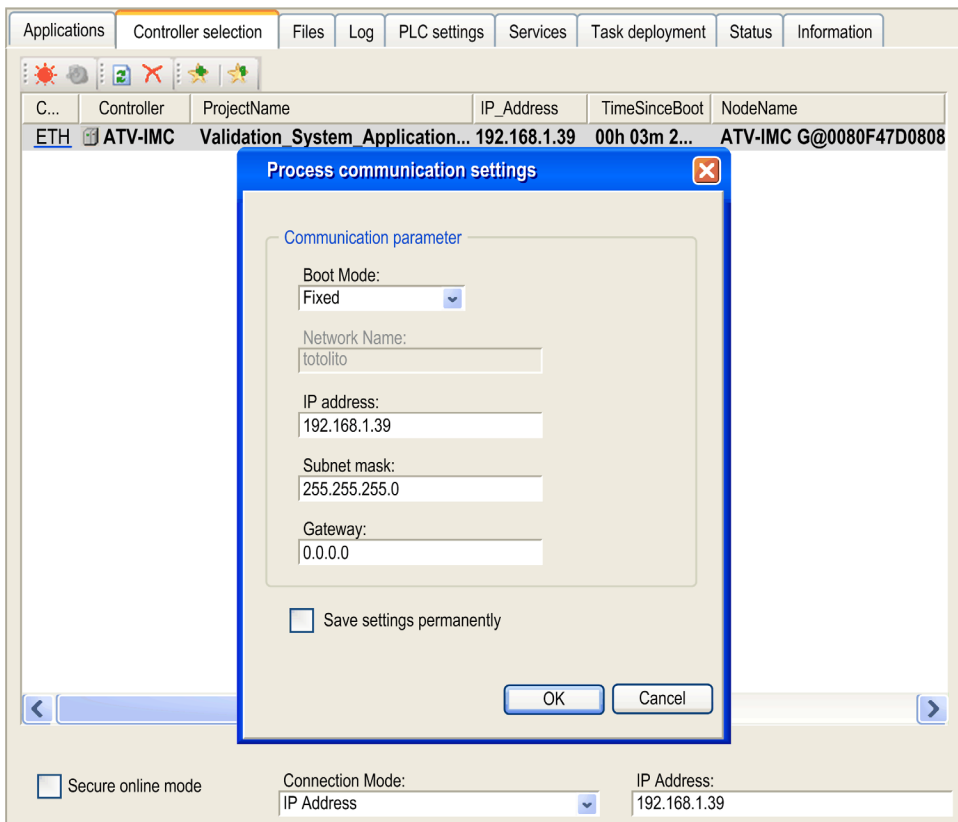

You can configure the Ethernet settings in the **Process communication settings** window in 2 ways:

- Without the **Save settings permanently** option:
Configure the communication parameters and click **OK**. These settings are immediately taken into account and are not kept if the controller is reset. For the next resets, the communication parameters configured into the application are taken into account.
- With the **Save settings permanently** option:
You can also check the **Save settings permanently** option before you click **OK**. Once this option is checked, the Ethernet parameters configured here are always taken into account on reset instead of the Ethernet parameters configured into the SoMachine application. Refer to Ethernet Setup (read - write) ([see page 102](#)) and Setup Page ([see page 114](#)).

For more information on the **Controller selection** view of the device editor, refer to the SoMachine Programming Guide.

Services

Services Tab

The **Services** tab is divided in 2 parts:

- RTC Configuration
- Device Identification

The figure below shows the **Services** tab:

NOTE: To have controller information, you must be connected to the controller.

Element		Description
RTC Configuration	PLC time	Displays the date/time read from the controller. This read-only field is initially empty. To read and display the date/time saved on the controller, click the Read button.
	Local time	Lets you define a date and a time that are sent to the controller by clicking the Write button. A message box informs you on the success of the command. Local time fields are initialized with the current PC settings.
	Synchronize with local date/time	Lets you directly send the current PC settings. A message box informs you on the success of the command.
Device Identification		Displays the Firmware version and the Boot Version of the selected controller, if connected.

Chapter 10

Local Input/Output Configuration

Overview

This chapter shows the local I/O configuration editor and the list of parameters.

What Is in This Chapter?

This chapter contains the following topics:

Topic	Page
Local I/O Configuration	68
Addressing	70

Local I/O Configuration

Introduction

The embedded inputs are composed of 6 fast inputs and 4 standard inputs.

The table below shows the available inputs and outputs.

I/O	Designation
10 Digital Inputs	LI51 to LI60
6 Digital Outputs	LO51 to LO56
2 Analog Inputs	AI51 and AI52
2 Analog Outputs	AO51 and AO52

Accessing the Configuration Tab

This table describes how to access the **Configuration** tab:

Step	Action
1	In the Devices tree , double-click MyController → Embedded IO → IO . Result: the IO screen is displayed.
2	Select the Configuration tab.

Configuring the Analog Inputs

To configure the inputs, double-click **Value**. The **Value** column now lets you configure the analog input mode **Voltage** (0...5 Vdc) or **Current** (0...20 mA).

RUN/STOP Function Configured on Digital Input

You can configure one of the digital inputs to perform the RUN/STOP function.

The RUN/STOP function stops a program by using the configured input.

- When the configured RUN/STOP input is at logic 0, the controller is put into a STOP state and any SoMachine command to enter the RUN state is ignored.
- When the configured RUN/STOP input is at logic 1, then the controller accepts RUN commands.

I/O Mapping Tab

This table describes the properties of the **I/O Mapping** tab:

Variable		Channel	Type	Description
Digital Inputs	ixIO_CI_LI51 ... ixIO_CI_LI60	CI_LI51 ... CI_LI60	BOOL	Fast Input for CI_LI51, CI_LI52, CI_LI53, CI_LI54, CI_LI59, and CI_LI60
Digital Outputs	qxIO_CI_LO51 ... qxIO_CI_LO56	CI_LO51 ... CI_LO56	BOOL	–
Analog Inputs		CI_AI51 CI_AI55	WORD	–
Analog Outputs		CI_AO51 CI_AO55	WORD	–

Configuration Tab

This table describes the properties of the **Configuration** tab:

Parameter			Value	Default Value	Description
Digital Inputs	CI_RUN_STOP_LI	Run/Stop	None CI_LI53 CI_LI54 CI_LI55 CI_LI55 CI_LI57 CI_LI58	None	Run/Stop input can be used to run or stop a program in the controller.
Analog Inputs	CI_AI51_PARAM	Input Mode	Current Voltage	Current	Configuration of analog input mode: Current or Voltage.
	CI_AI52_PARAM	Input Mode	Current Voltage	Current	Configuration of analog input mode: Current or Voltage.

Addressing

Addressing Methods

SoMachine allows you to program instructions with 2 different methods of parameter usage:

- symbolic addresses, also called indirect addresses
- immediate addresses, also called direct addresses

SoMachine allows you to program instructions using either a direct or indirect method of parameter usage. The direct method is called Immediate Addressing where you use a parameter's direct address, such as %IWx or %QWx for example. The indirect method is called Symbolic Addressing where you first define symbols for these same parameters, and then use the symbols in association with your program instructions.

Both methods are valid and acceptable, but Symbolic Addressing offers distinct advantages, especially if you later make modifications to your configuration. When you configure I/O and other devices for your application, SoMachine automatically allocates and assigns the immediate addresses. Afterward, if you add or delete I/O or other devices from your configuration, SoMachine will account for any changes to the configuration by reallocating and reassigning the immediate addresses. This necessarily will change the assignments from what they had once been from the point of the change(s) in the configuration.

If you have already created all or part of your program using immediate addresses, you will need to account for this change in any program instructions, function blocks, etc., by modifying all the immediate addresses that have been reassigned. However, if you use symbols in place of immediate addresses in your program, this action is unnecessary. Symbols are automatically updated with their new immediate address associations provided that they are attached to the address in the I/O Mapping dialog of the corresponding Device Editor, and not simply an 'AT' declaration in the program itself.

WARNING

UNINTENDED EQUIPMENT OPERATION

Inspect and modify as necessary any immediate addresses used in the program after modifying the configuration.

Failure to follow these instructions can result in death, serious injury, or equipment damage.

NOTE: Schneider Electric highly recommends the systematic use of symbols while programming to avoid extensive program modifications and to limit the possibility of programming anomalies once a program configuration has been modified by adding or deleting I/O or other devices.

Chapter 11

Local HSC Configuration

Overview

This chapter shows the local HSC configuration editor and the list of parameters.

For more information, refer to the HSC Library User Manual (see *Altivar ATV IMC Drive Controller, High Speed Counting, ATV IMC HSC Library Guide*):

What Is in This Chapter?

This chapter contains the following topics:

Topic	Page
HSC Types	72
HSC Configuration Screen Description	73

HSC Types

HSC Types for ATV IMC

ATV IMC provides 2 HSC types:

- **Simple** type for basic functions
- **Main** type for extended functions

The following table gives an overview of the 2 types:

Type	Modes	Description
Simple	<ul style="list-style-type: none"> ● One-Shot ● Modulo-loop 	Edge synchronization for counting is Rising edge
Main	<ul style="list-style-type: none"> ● One-Shot ● Modulo-loop ● Free-large ● Event ● Frequency meter 	<ul style="list-style-type: none"> ● The Enable and Preset signals can be triggered by hardware inputs. ● Allows to configure the edge synchronization for counting by means of Count Edge: <ul style="list-style-type: none"> ● Rising edge ● Falling edge ● Both edges ● Allows to configure the Count Direction (depends on the mode): <ul style="list-style-type: none"> ● UP ● DOWN

For a further description of the HSC modes, please refer to the HSC Library User Manual (see *Altivar ATV IMC Drive Controller, High Speed Counting, ATV IMC HSC Library Guide*).

HSC Configuration Screen Description

Local HSC Configuration Screen

To open the **HSC** configuration screen, proceed as follows:

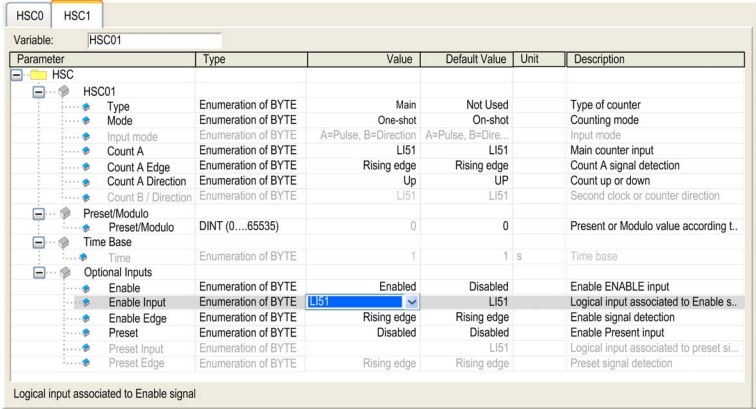
Step	Action
1	<p>In the Devices tree, double-click MyController → Embedded IO → HSC. Result: this window is displayed.</p> 
2	Select one of these tabs according to the HSC channel you need to configure.
3	After choosing the HSC type you want, the variable field can be used to change the HSC instance name.
4	If the parameters are collapsed, you can expand them by clicking the plus sign. Then you can access to the setting of each parameter.
5	Enter/choose/select the parameter value.

ATV IMC implements 2 high speed counters:

- **HSC 0**
- **HSC 1**

For a further description of the HSC modes, please refer to the HSC Library User Manual (see *Altivar ATV IMC Drive Controller, High Speed Counting, ATV IMC HSC Library Guide*).

HSC I/O Mapping

The following table lists the embedded input availability for HSC functions according to the inputs:

Digital Input	Fast Input	Usage For HSC	
		HSC Fast Input	HSC Standard Input
LI51	X	X	X
LI52	X	X	X
LI53	X	-	-
LI54	X	-	-
LI55	-	-	-
LI56	-	-	X
LI57	-	-	X
LI58	-	-	-
LI59	X	X	X
LI60	X	X	X

Chapter 12

ATV IMC Resident Drive Data Configuration

Introduction

This chapter shows you how to configure and use the ATV IMC dedicated data:

What Is in This Chapter?

This chapter contains the following topics:

Topic	Page
ATV IMC Resident Drive Configuration and Usage	76
ATV IMC Display Data Configuration and Usage	78
ATV IO Option Board	80

ATV IMC Resident Drive Configuration and Usage

Introduction

The ATV IMC resident drive is configured by means of the **Drive Editor**. This is configured data for implicit exchanged between the drive and the IMC.

ATV IMC Drive Editor Screen

To open the **Drive Editor**, proceed as follows:

Step	Action
1	In the Devices tree , double-click MyController → Local → Drive . Result: The configuration window is displayed.
2	Select the Pix/POx Configuration tab.

The screenshot shows the 'Pix/POx Configuration' tab in the Drive Editor. It features two main sections: 'Drive cyclic read' and 'Drive cyclic write'. Each section contains a table with three columns: 'Code', 'Address', and 'Long Label'. The 'Drive cyclic read' section has 8 rows, with the first row (Drive_PI1) populated with 'LAC', '3006', and 'Level of access control'. The 'Drive cyclic write' section has 5 rows (Drive_PO1 to Drive_PO5), all of which are empty.

Drive cyclic read			
	Code	Address	Long Label
Drive_PI1	LAC	3006	Level of access control
Drive_PI2			
Drive_PI3			
Drive_PI4			
Drive_PI5			
Drive_PI6			
Drive_PI7			
Drive_PI8			

Drive cyclic write			
	Code	Address	Long Label
Drive_PO1			
Drive_PO2			
Drive_PO3			
Drive_PO4			
Drive_PO5			

I/O Mapping Tab

This table describes the properties of the **I/O Mapping** tab:

Variable	Channel	Type
Drive Cyclic Parameters Read	DRIVE_PI1 ... DRIVE_PI8	WORD
Drive Cyclic Parameters Write	DRIVE_PO1 ... DRIVE_PO8	WORD
Drive IOs	–	DRIVE_AI1 DRIVE_AI2 DRIVE_AO1
	ixDrive_DRIVE_LI1 ... ixDrive_DRIVE_LI6	DRIVE_LI1 ... DRIVE_LI6
	qxDrive_DRIVE_RELAY1 qxDrive_DRIVE_RELAY2	DRIVE_RELAY1 DRIVE_RELAY2

NOTE: The drive digital outputs %QW24.0, %QW24.1 as well as the analog output %QW11 are inoperative when they have been assigned to a drive function in the resident drive configuration.

Select the variables to be attached by clicking the symbol in the column **Mapping**.

PIx/POx Configuration

The task **PIx/POx Configuration** allows you to configure the drive parameters for cyclic exchanges.

Click a button, for example **Drive_PI1**, in the first columns.

Result: a dialog box opens with selectable variables **Code** and **Logical Address** to exchange cyclically.

When an ATV IMC drive controller is plugged to a drive, by default all the digital and analog outputs of the drive are managed by the ATV IMC drive controller. To block the access of the digital and analog outputs of the drive, change the register values of the drive by using the `DriveParameterWrite1` (see *Altivar ATV IMC Drive Controller, ATV IMC UserLib Library Guide*) program.

For example: To block the access to the logic (digital) outputs, set the registers as followed:

```
Write [PP01] = 5212 (PPO01= Parameter Protection 01 address = 39003 //
5212 = OL1R = address logic digital outputs real image (bit0 = LI1...) 8
Relays + 8 LO)
```

```
Write [PCD] = 0x400 (OCD = Channel protection definition address = 39001
// 0x400 = bit 10 = Application channel card)
```

```
Write [PPRQ] = 2 (PPRQ = Parameter Protection requestion address = 39023
// 2 = ask protection, 3 = release protection)
```

ATV IMC Display Data Configuration and Usage

Introduction

The ATV local drive HMI offers a dedicated menu for ATV IMC controller, called ATV IMC display. The ATV IMC display can be customized in order to display up to 50 parameters that are exchanged between the drive and the Altivar ATV IMC Drive Controller.

Data Exchange

The parameters that are exchanged between the drive and the ATV IMC controller are accessible in SoMachine software by using `Display_Ox` (with $x=01\dots50$) variables.

After a Run Command (see page 53), the first update of these variables is done only when `xglobalInit`¹ = FALSE.

¹`xglobalInit` is a global variable of the UserLib Library.

ATV IMC Display Configuration

To open the **Display Editor** proceed as follows:

Step	Action
1	In the Devices tree , double-click MyController → Local → Display . Result: The Display window is displayed.
2	Select the Display configuration tab.

Display Editor

The **Display Editor** provides these tabs:

Tab	Description
I/O Mapping	The I/O Mapping allows you to Create new variables or to Map to existing variable for 50 parameters on 1 menu.
Display configuration	The Display configuration allows you to configure the ATV IMC keypad menu.
List 1 to List 4	The 4 lists provide 50 parameters in total. Enter a Short Label of maximum 5 characters and a Long Label of maximum 9 characters.

Display Configuration

The **Display configuration** lets you configure the ATV IMC keypad menu.

OxNumber	Enable	Name	Type	Min	Max	Sign	Decimal	List	Unit	Opti...
...	<input checked="" type="checkbox"/>	Display...	ENAB...	Disp...	NUM...	0	65535	Not...	No com...	CONF
...	<input checked="" type="checkbox"/>	Displ...	DISA...	Disp...	NUMERIC	0	65535	Not...	No com...	NO...
...	<input checked="" type="checkbox"/>	Displ...	DISA...	Disp...	BITFIELD	0	65535	Not...	No com...	NO...
...	<input checked="" type="checkbox"/>	Displ...	DISA...	Disp...	LIST PRECO...	0	65535	Not...	No com...	NO...
...	<input checked="" type="checkbox"/>	Displ...	DISA...	Disp...	LIST CUSTO...	0	65535	Not...	No com...	NO...
...	<input checked="" type="checkbox"/>	Displ...	DISA...	Disp...	NUMERIC	0	65535	Not...	No com...	NO...
...	<input checked="" type="checkbox"/>	Displ...	DISA...	Disp...	NUMERIC	0	65535	Not...	No com...	NO...
...	<input checked="" type="checkbox"/>	Displ...	DISA...	Disp...	NUMERIC	0	65535	Not...	No com...	NO...
...	<input checked="" type="checkbox"/>	Displ...	DISA...	Disp...	NUMERIC	0	65535	Not...	No com...	NO...
...	<input checked="" type="checkbox"/>	Displ...	DISA...	Disp...	NUMERIC	0	65535	Not...	No com...	NO...
...	<input checked="" type="checkbox"/>	Displ...	DISA...	Disp...	NUMERIC	0	65535	Not...	No com...	NO...

Display_001

The **Display configuration** provides these parameters:

Parameters	Description
Menu Name	Allows you to enter a Menu name of your choice.
Enable	Allows you to validate visibility of parameters in the graphic keypad.
Type	Allows you to manage 4 parameter types: <ul style="list-style-type: none"> ● NUMERIC ● BITFIELD ● LIST PRECONFIGURED ● LIST CUSTOMIZABLE
Sign	If Signed is selected, you can configure the NUMERIC type between a minimum of -32768 and a maximum of 32767.
Option	Allows you to configure the following Options : <ul style="list-style-type: none"> ● CONF: configuration parameter is not stored. ● CONF_STORE: configuration parameter is stored in the program (in a variable called <code>Saved_Display_Ox</code>). ● CONF_RUNLOCK: configuration parameter is not stored and can not be modified when the drive is in run. ● CONF_RUNLOCK_STORE: configuration parameter is stored in the program (in a variable called <code>Saved_Display_Ox</code>) and can not be modified when the drive is in run. ● MONITORING: read-only parameter. <p>NOTE: An example to restore the stored values can be visualized in the <code>Display_RestoreSavedParameters</code> POU of the ATV template (see page 15).</p>

ATV IO Option Board

Configuring the Option Board

The option board is the additional IO option card mounted on the ATV (61 or 71) variable speed drive. For more information about the option cards, refer to the ATV catalog.

To configure the IO option card on the Altivar ATV IMC Drive Controller, proceed as follows:

Step	Action
1	Select the option board you want (IO_Basic or IO_Extended) in the Hardware Catalog , drag it to the Devices tree , and drop it on one of the highlighted nodes. For more information on adding a device to your project, refer to: <ul style="list-style-type: none">• Using the Drag-and-drop Method (<i>see SoMachine, Programming Guide</i>)• Using the Contextual Menu or Plus Button (<i>see SoMachine, Programming Guide</i>)
2	Double-click the created node.

Chapter 13

Ethernet Configuration

Introduction

This chapter describes how to configure the Ethernet network interface of the ATV IMC.

What Is in This Chapter?

This chapter contains the following topics:

Topic	Page
Ethernet Services	82
IP Address Configuration	84
Modbus TCP Slave Device	89
Modbus TCP Server	92
System Variables Description	94

Ethernet Services

Ethernet Services

The controller supports the following services:

- FTP Server,
- Web Server,
- Modbus TCP Server (slave),
- SoMachine Manager.

Ethernet Protocol

The controller supports the following protocols:

- Bootp (Served Configuration Protocol)
- DHCP (Dynamic Host Configuration Protocol)
- HTTP (Hyper Text Transfer Protocol)
- FTP (File Transfer Protocol)
- IP (Internet Protocol),
- UDP (User Datagram Protocol),
- TCP (Transmission Control Protocol),
- ARP (Address Resolution Protocol),
- ICMP (Internet Control Messaging Protocol).

TCP Server Connection

This table shows the maximum number of TCP server connection:

Connection Type	Maximum Number of Server Connection
Modbus Server	8
Modbus Device	2
FTP Server	4
Web Server	6

Each server based on TCP manages its own pool of 6 simultaneous HTTP connections.

When a client tries to open a connection that exceeds the pool size, the controller closes the oldest.

If all connections are busy (exchange in progress) when a client tries to open a new one the new connection is denied.

All server connections stay open as long as the controller stays in operational state.

Adding an Ethernet Manager

The controller supports the Modbus TCP Slave Device Ethernet manager.

To add an Ethernet manager, proceed as follows:

Step	Action
1	Select the Field Devices tab in the Software Catalog and click Modbus .
2	Select ModbusTCP Slave Device → ModbusTCP Slave Device (Vendor Schneider Electric) in the list, drag-and-drop the item onto Ethernet node of the Devices tree . Result: The module is added to the My Controller → Ethernet area of the Devices tree . Note: The other Ethernet managers are not supported.

IP Address Configuration

Introduction

There are different ways to assign the IP address of the controller:

- address assignment by DHCP server
- address assignment by BOOTP server
- fixed IP address

IP address can be changed dynamically:

- via the Controller Selection tab in SoMachine.

NOTE: If the attempted addressing method is unsuccessful, the controller will start using a default IP address ([see page 87](#)) derived from the MAC address.

NOTE: After you download a project with a new IP address, a power cycle is required to take the new IP address into account.

Carefully manage the IP addresses because each device on the network requires a unique address. Having multiple devices with the same IP address can cause unpredictable operation of your network and associated equipment.

WARNING

UNINTENDED EQUIPMENT OPERATION

- Verify that there is only one master controller configured on the network or remote link.
- Verify that all devices have unique addresses.
- Obtain your IP address from your system administrator.
- Confirm that the device's IP address is unique before placing the system into service.
- Do not assign the same IP address to any other equipment on the network.
- Update the IP address after cloning any application that includes Ethernet communications to a unique address.

Failure to follow these instructions can result in death, serious injury, or equipment damage.

NOTE: Verify that your system administrator maintains a record of all assigned IP addresses on the network and subnetwork, and inform the system administrator of all configuration changes performed.

Address Management

The different types of address systems for the controller are shown in this diagram:

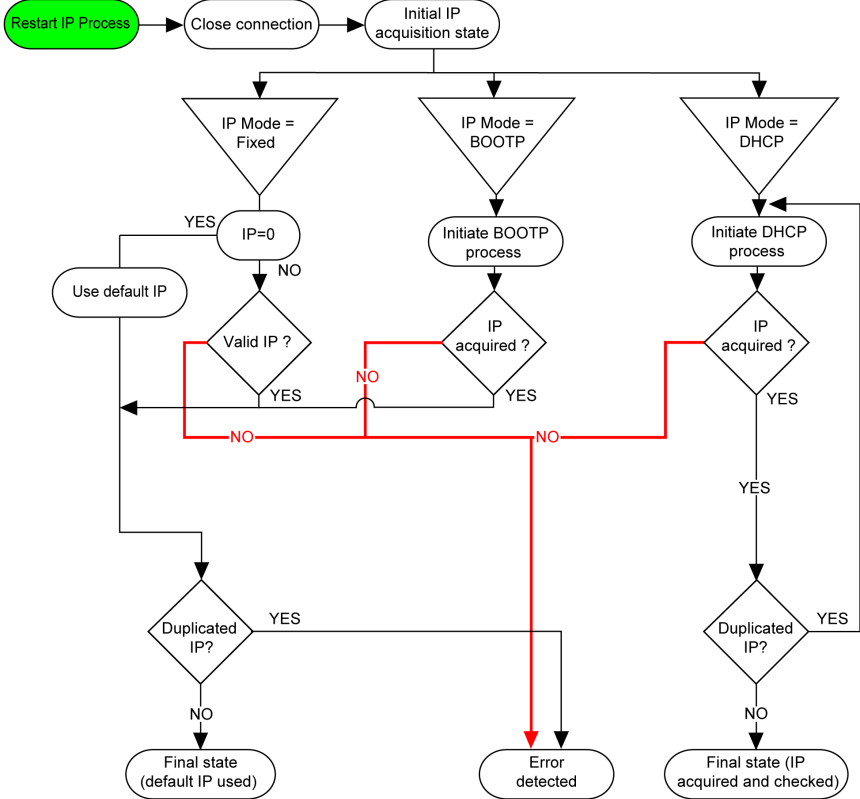

Ethernet Configuration

In the **Devices tree**, double-click **Ethernet**:

The screenshot shows the 'Ethernet Configuration' window. It has a 'Configuration' tab and is divided into two sections: 'Configured Parameters' and 'Security Parameters'.

Configured Parameters:

- Interface Name: ether0
- Network Name: myDevice
- IP Address by DHCP:
- IP Address by BOOTP:
- fixed IP Address: (Selected)
- IP Address: 0 . 0 . 0 . 0
- Subnet Mask: 0 . 0 . 0 . 0
- Gateway Address: 0 . 0 . 0 . 0
- Transfer Rate: Auto (dropdown menu)

Security Parameters:

- SoMachine protocol active
- Modbus Server active
- Web Server active
- FTP Server active
- Discovery protocol active
- SNMP protocol active

The configured parameters are explained as below:

Configured Parameters	Description
Interface Name	Name of the network link.
Network Name	Used as device name to retrieve IP address through DHCP, maximum 16 characters.
IP Address by DHCP	IP address is obtained via DHCP.
IP Address by BOOTP	IP address is obtained via BOOTP.
Fixed IP Address	IP address, Subnet Mask, and Gateway Address are defined by the user.
Transfer Rate	Transfer rate and direction on the bus are automatically configured.

NOTE: The configured parameters are applied only if the option **Parameters Updated by Application** is enabled. Refer to Ethernet Setup (read - write) ([see page 102](#)) and Setup Page ([see page 114](#)).

Default IP Address

The IP address by default is 10.10.x.x.

The last 2 fields in the default IP address are composed of the decimal equivalent of the last 2 hexadecimal bytes of the MAC address of the port.

The MAC address of the port can be retrieved on the label placed on the front side of the controller.

The default subnet mask is Default Class A Subnet Mask of 255.0.0.0.

NOTE: A MAC address is always written in hexadecimal format and an IP address in decimal format. Convert the MAC address to decimal format.

Example: If the MAC address is 00.80.F4.01.80.F2, the default IP address is 10.10.128.242.

NOTE: To take into account the new IP address after the download of a project, reboot the controller by doing a power cycle.

Address Classes

The IP address is linked:

- to a device (known as the host)
- to the network to which the device is connected

An IP address is always coded using 4 bytes.

The distribution of these bytes between the network address and the device address may vary. This distribution is defined by the address classes.

The different IP address classes are defined in this table:

Address Class	Byte 1			Byte 2	Byte 3	Byte 4	
Class A	0	Network ID			Host ID		
Class B	1	0	Network ID			Host ID	
Class C	1	1	0	Network ID			Host ID
Class D	1	1	1	0	Multicast Address		
Class E	1	1	1	1	0	Address reserved for subsequent use	

Subnet Mask

The subnet mask is used to address several physical networks with a single network address. The mask is used to separate the subnetwork and the device address in the host ID.

The subnet address is obtained by retaining the bits of the IP address that correspond to the positions of the mask containing 1, and replacing the others with 0.

Conversely, the subnet address of the host device is obtained by retaining the bits of the IP address that correspond to the positions of the mask containing 0, and replacing the others with 1.

Example of a subnet address:

IP address	192 (11000000)	1 (00000001)	17 (00010001)	11 (00001011)
Subnet mask	255 (11111111)	255 (11111111)	240 (11110000)	0 (00000000)
Subnet address	192 (11000000)	1 (00000001)	16 (00010000)	0 (00000000)

NOTE: The device does not communicate on its subnetwork when there is no gateway.

Gateway

The gateway allows a message to be routed to a device that is not on the current network.

If there is no gateway, the gateway address is 0.0.0.0.

Security Parameters

Security Parameters	Description
SoMachine protocol active	It allows you to deactivate the SoMachine protocol on Ethernet interfaces. When deactivated, every SoMachine request from every device will be rejected, including those from the UDP or TCP connection. This means that no connection is possible on Ethernet from a PC with SoMachine, from an HMI target that wants to exchange variables with this controller, from an OPC server, or from Controller Assistant.
Modbus Server active	It allows you to deactivate the Modbus Server of the Logic Controller. This means that every Modbus request to the Logic Controller will be ignored.
Web Server active	It allows you to deactivate the Web Server of the Logic Controller. This means that every HTTP request to the Logic Controller will be ignored.
FTP Server active	It allows you to deactivate the FTP Server of the Logic Controller. This means that every FTP request will be ignored.
Discovery protocol active	It allows you to deactivate Discovery protocol. This means that every Discovery request will be ignored.
SNMP protocol active	Not available.

Modbus TCP Slave Device

Overview

This section describes how to set your controller as a slave device on a Modbus network. For more complete information about Modbus TCP, refer to the www.modbus.org website.

Adding a Modbus TCP Slave Device

See Adding an Ethernet Manager (*see page 83*).

Modbus TCP Slave Device Configuration

To configure the controller as a Modbus TCP slave device, proceed as follows:

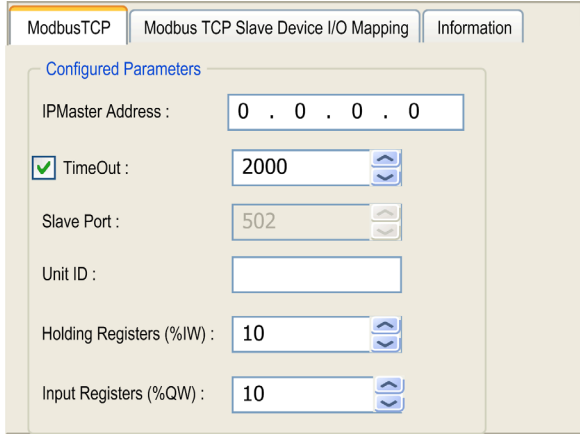
Step	Action
1	<p>In the Devices tree, double-click ModbusTCP Slave Device (ModbusTCP Slave Device). The following dialog box appears:</p> 

Element	Description
IP Master Address	<p>IP address of the Modbus master. TCP Modbus requests are only accepted if coming from the Master.</p> <p>NOTE: In this case, only the Master can access the WEB server.</p>
TimeOut	<p>Timeout in ms (step 500 ms)</p> <p>NOTE: The timeout applies to the IP Master Address unless if the address is 0.0.0.0.</p>

Element	Description
Slave Port	Modbus communication port (502 by default) NOTE: Check that the port 502 is open in the Ethernet network.
Unit ID	Modbus slave address (255)
Holding Registers (%IW)	Size of the input assembly in bytes (2...40 bytes)
Input Registers (%QW)	Size of the output assembly in bytes (2...40 bytes)

I/O Mapping Tab

The I/Os are mapped to Modbus registers from Master point of view as following:

- %IW's are mapped from register 0 to n-1 and are R/W (n = Holding register quantity)
- %QW's are mapped from register 0 to m -1 (m = Input registers quantity) and are read only.

The controller responds to a subset of the normal Modbus commands, but does so in a way that differs from normal Modbus standards, and with the purpose of exchanging data with the external I/O scanner. The following Modbus commands may be issued to the controller:

Function Code Dec (Hex)	Function	Comment
3 (3h)	Read holding register	Allow Master IO Scanner to read %IW and %QW of the controller
16 (10h)	Write multiple registers	Allow Master IO Scanner to Write %IW of the controller
23 (17h)	Read/write multiple registers	Allow Master IO Scanner to read %IW and %QW of the controller and Write %IW of the controller
Other	Not supported	

NOTE: Modbus requests that attempt to access registers above n+m-1 are answered by the 02 - ILLEGAL DATA ADDRESS exception code.

To link I/O to variables, select the **Modbus TCP Slave Device I/O Mapping** tab:

Channel		Type	Description
Input	IW0	WORD	Modbus Holding register 0

	IWx	WORD	Modbus Holding register x
Output	QW0	WORD	Modbus Input register 0

	QWy	WORD	Modbus Input register y

The number of word depends on the **Holding Registers (%IW)** and **Input Registers (%QW)** parameters of the ModbusTCP tab.

NOTE: Output means OUTPUT for the Modbus Master (= %IW for the controller).

Input means INPUT for the Modbus Master (= %QW for the controller).

Modbus TCP Server

Introduction

Without any other configuration on the Ethernet port, the controller supports Modbus Server.

The transfer of information between a Modbus client and server is initiated when the client sends a request to the server to transfer information, to execute a command, or to perform one of many other possible functions.

After the server receives the request, it executes the command or retrieves the required data from its memory. The server then responds to the client by either acknowledging that the command is complete or by providing the requested data.

External Communications through Modbus TCP Server

The following **Unit IDs** are used for external Modbus TCP client:

Unit ID	Accessible Parameters
0, 248	Variable speed drive, see the Altivar 61/71 communication parameters
252, AMOA	Located variables (%MW0 . . . %MW59999) System Variable (see page 94) (%MW60000 . . . %MW62500) ⁽¹⁾
253	To read the local inputs (%IW) Function code: 3 (3 hex) Read holding register (%IW)
254	To read or write the local outputs (%QW) Function code: 3 (3 hex) Read holding register (%QW) 6 (6 hex) Write single register (%QW) 16 (10 hex) Write multiple registers (%QW)
255	IOScanner default value for Unit ID of Modbus TCPslave device
⁽¹⁾ Not accessible through the application.	

Modbus TCP Server

For the **Unit ID 252 AMOA**, the following function codes are valid:

Function Code Dec (Hex)	Sub-function Dec (Hex)	Function
1 (1 hex)	–	Read digital outputs (%Q)
2 (2 hex)	–	Read digital inputs (%I)
3 (3 hex)	–	Read holding register (%MW)
6 (6 hex)	–	Write single register (%MW)
15 (F hex)	–	Write multiple digital outputs (%Q)

Function Code Dec (Hex)	Sub-function Dec (Hex)	Function
16 (10 hex)	–	Write multiple registers (%MW)
23 (17 hex)	–	Read/write multiple registers (%MW)
43 (2B hex)	14 (E hex)	Read device identification

Read Device Identification Request

The table below list the objects that can be read with a read device identification request (basic identification level):

Object ID	Object Name	Type	Value
00 hex	Vendor name	ASCII string	Schneider Electric
01 hex	Product code	ASCII string	Controller reference
02 hex	Major / minor revision	ASCII string	aa.bb.cc.dd (same as device descriptor)

System Variables Description

Variable Structure

The following table describes the parameters of the PLC_R System Variable (PLC_R_STRUCT type):

Modbus Address ⁽¹⁾	Var Name	Type	Comment
60000	i_wVendorID	WORD	Controller Vendor ID. 101A hex = Schneider Electric
60001	i_wProductID	WORD	Controller Reference ID. NOTE: Vendor ID and Reference ID are the components of the Target ID of the Controller displayed in the Communication Settings view (Target ID = 101A XXXX hex).
60002	i_dwSerialNumber	DWORD	Controller Serial Number
60004	i_byFirmVersion[0..3]	ARRAY[0..3] OF BYTE	Controller Firmware Version [aa.bb.cc.dd]: <ul style="list-style-type: none"> ● i_byFirmVersion[0] = aa ● ... ● i_byFirmVersion[3] = dd
60006	i_byBootVersion[0..3]	ARRAY[0..3] OF BYTE	Controller Boot Version [aa.bb.cc.dd]: <ul style="list-style-type: none"> ● i_byBootVersion[0] = aa ● ... ● i_byBootVersion[3] = dd
60008	i_dwHardVersion	DWORD	Controller Hardware Version.
60010	i_dwHardwareID	DWORD	Controller Coprocessor Version.
60012	i_wStatus	PLC_R_STATUS (see <i>Altivar ATV IMC Drive Controller, System Functions and Variables, ATV-IMC PLCSystem Library Guide</i>)	State of the controller.

Modbus Address ⁽¹⁾	Var Name	Type	Comment
60013	i_wBootProjectStatus	PLC_R_BOOT_PROJECT_STATUS (see <i>Altivar ATV IMC Drive Controller, System Functions and Variables, ATV-IMC PLCSystem Library Guide</i>)	Returns information about the boot application stored in FLASH memory.
60014	i_wLastStopCause	PLC_R_STOP_CAUSE (see <i>Altivar ATV IMC Drive Controller, System Functions and Variables, ATV-IMC PLCSystem Library Guide</i>)	Cause of the last transition from RUN to another state.
60015	i_wLastApplicationError	PLC_R_APPLICATION_ERROR (see <i>Altivar ATV IMC Drive Controller, System Functions and Variables, ATV-IMC PLCSystem Library Guide</i>)	Cause of the last controller exception.

Modbus Address ⁽¹⁾	Var Name	Type	Comment
60016	i_lwSystemFault_1	LWORD	<p>Bit field FFFF FFFF FFFF FFFF hex indicates no detected error. A bit at low level means that an error has been detected:</p> <ul style="list-style-type: none"> ● bit 0 = Detected error on ATV-IMC internal link ● bit 1 = Ethernet link not connected ● bit 2 = USB link not connected ● bit 3 = CANopen link not running ● bit 4 = Modbus/TCP time-out ● bit 5 = Duplicate IP address detected ● bit 6 = Overload detected on Ethernet network ● bit 7 = Detected error on Ethernet hardware ● bit 8 = Detected error on non-volatile memory ● bit 9 = CAN communication messaging detected error ● bit 10 = Detected error on ATV-IMC object dictionary ● bit 11 = Hardware watchdog detected error ● bit 12 = Internal detected error ● bit 13 = Logical output detected error (over temperature) ● bit 14 = Logical output 24V power supply inoperative ● bit 15-63: Not used <p>NOTE: Bit 11 and bit 12 can be reset using the function ResetInternalErrorDiag (see <i>Altivar ATV IMC Drive Controller, System Functions and Variables, ATV-IMC PLCSystem Library Guide</i>).</p>
60020	i_lwSystemFault_2	LWORD	Not used.
60024	i_wIOStatus1	PLC_R_IO_STATUS (see <i>Altivar ATV IMC Drive Controller, System Functions and Variables, ATV-IMC PLCSystem Library Guide</i>)	Embedded I/O status.

Modbus Address ⁽¹⁾	Var Name	Type	Comment
60025	i_wIOStatus2	PLC_R_IO_STATUS (see <i>Altivar ATV IMC Drive Controller, System Functions and Variables, ATV-IMC PLCSystem Library Guide</i>)	Not used (always FFFF hex).
60026	i_wBatteryStatus	PLC_R_BATTERY_STATUS (see <i>Altivar ATV IMC Drive Controller, System Functions and Variables, ATV-IMC PLCSystem Library Guide</i>)	Real Time Clock battery status.
60028	i_dwAppliSignature1	DWORD	First DWORD of 4 DWORD signature (16 bytes total). The application signature is generated by the software during build.
60030	i_dwAppliSignature2	DWORD	Second DWORD of 4 DWORD signature (16 bytes total). The application signature is generated by the software during build.
60032	i_dwAppliSignature3	DWORD	Third DWORD of 4 DWORD signature (16 bytes total). The application signature is generated by the software during build.
60034	i_dwAppliSignature4	DWORD	Fourth DWORD of 4 DWORD signature (16 bytes total). The application signature is generated by the software during build.
⁽¹⁾ Not accessible through the application.			

n/a	i_sVendorName	STRING (31)	Name of the vendor: "Schneider Electric".
n/a	i_sProductRef	STRING (31)	Reference of the Controller.

NOTE: n/a means that there is no pre-defined Modbus Address mapping for this System Variable.

Ethernet Diagnostic (read only)

Modbus Address ⁽¹⁾	Identification	Type	Comments
60050	MY_ACTUAL_IP_ADDR	BYTE (4)	Actual IP address.
60052	MY_ACTUAL_IP_SUBMASK	BYTE (4)	Actual SubNet mask.
60054	MY_ACTUAL_IP_GATEWAY	BYTE (4)	Actual Gateway.
60056	NVMEMORY_MAC_ADDR	BYTE (6)	MAC address.
60059	NVMEMORY_DEVICENAME	STRING (16)	Actual DeviceName.
60067	MY_ACTUAL_BOOTUP_MODE	WORD	<ul style="list-style-type: none"> ● 0: DHCP ● 1: BootP ● 2: Stored ● FF hex: Default IP
60068	FTP_SERVER_IP_ADDR	BYTE (4)	Give IP adress of DHCP or BootP server that gave IP parameters used =0.0.0.0 if stored IP or default IP used.
60070	OPEN TCP CONNECTION	UDINT	Open TCP connection.
60072	MY_FRAMEPROTOCOLE	WORD	<ul style="list-style-type: none"> ● 1: Ethernet II ● 0: 802.3 (not managed by ATV IMC)
60073	STAT_ETH_TX_FRAMES	UDINT	Count of frames that are successfully transmitted. Reset at power on or with reset stat command.
60075	STAT_ETH_RX_FRAMES	UDINT	Count of frames that are successfully received. Reset at power on or with reset stat command.
60077	STAT_ETH_TX_BUFFER_ERRORS	UDINT	Reset at power on or with reset stat command.
60079	STAT_ETH_RX_BUFFER_ERRORS	UDINT	Reset at power on or with reset stat command.
60081	MY_ACTUAL_LINK_STATUS	WORD	<ul style="list-style-type: none"> ● 1: Link Up ● 2: Link Down
60082	MY_ACTUAL_PHY_RATE	WORD	10 or 100.
60083	MY_ACTUAL_PHY_DUPLEX	WORD	<ul style="list-style-type: none"> ● 0: Half Duplex ● 1: Full Duplex
(1) Not accessible through the application.			

Specific Informations (read only)

Modbus Address ⁽¹⁾	Identification	Type	Comments
60200	NVMEMORY_MODBUS_TIMEOUT	WORD	Modbus/TCP timeout in ms.
60201	NVMEMORY_IOSCAN_ACTIVATION	WORD	<ul style="list-style-type: none"> ● 0: IOScanning disabled ● 1: IOScanning enabled

Modbus Address ⁽¹⁾	Identification	Type	Comments
60202	NVMEMORY_MODBUS_MASTER_IP_ADDR	BYTE (4)	If IPMaster is assigned, only the IPMaster can write through Modbus/TCP.
60204	MODBUS_TX_FRAMES	DWORD	Statistic: Number of Modbus frames sent.
60206	MODBUS_RX_FRAMES	DWORD	Statistic: Number of Modbus frames received.
60208	MODBUS_IOSCAN_TX	DWORD	Statistic: Number of Modbus IOScanning frames sent.
60210	MODBUS_IOSCAN_RX	DWORD	Statistic: Number of Modbus IOScanning frames received.
60212	MODBUS_MSG_ERRORS	WORD	Statistic: Number of Modbus frame detected errors sent.
60213	MODBUS_IOSCAN_ERRORS	WORD	Statistic: Number of Modbus IOScanning frames detected errors sent.
60214	MODBUS_TRAFFIC	WORD	Statistic: Number of Modbus frames received and sent the last second.
60215	MODBUS_MAX_TRAFFIC	WORD	Statistic: Maximum number of Modbus frames received in 1 second.
60216	MODBUS_NB_CONNECT	WORD	Statistic: Number of Modbus socket opened.
60217	STAT_ETH_TX_DIFF	WORD	Statistic: Number of deferred emission.
60218	STAT_ETH_LATE_COLISION	WORD	Statistic: Number of late collision.
60219	STAT_ETH_RX_CRC_ERRORS	WORD	Statistic: Number of CRC detected errors.
60220	STAT_ETH_RX_FRAMES_ERROR	WORD	Statistic: Number of reception frame detected errors.
60221	STAT_ETH_COLISIONS	WORD	Statistic: Total number of collisions.
60222	STAT_ETH_MULTICOLISION	WORD	Statistic: Number of multicollision.
60223	STAT_ETH_OVERRUN	WORD	Statistic: Number of overrun.
60224	MY_UDP_SOCKET_SRV_NBR	WORD	Statistic: Number of UDP socket server.
60225	DIGITAL INPUTS	WORD	1 digit per input.
60226	ANALOG INPUT 1	WORD	Analog input 1 value (Unit : mV or μ A depending on configuration).
60227	ANALOG INPUT 2	WORD	Analog input 2 value (Unit : mV or μ A depending on configuration).
60228	ANALOG INPUT CONFIG	WORD	Analog input configuration. 1 digit per input: <ul style="list-style-type: none"> ● 0: 0...10 Volt ● 1: 0...20 mA
60229	DIGITAL OUTPUT	WORD	1 digit per output.
60230	ANALOG OUTPUT 1	WORD	Analog output 1 value (Unit: μ A).
60231	ANALOG OUTPUT 2	WORD	Analog output 2 value (Unit: μ A).

Modbus Address ⁽¹⁾	Identification	Type	Comments
60232	DRIVE STATE	WORD	Drive state: <ul style="list-style-type: none"> ● 0: OFF (Drive not powered) ● 1: ON (Drive powered and Alcan com OK) ● 2: ILF (Internal Link Fault)
60233	FILE SYSTEM STAT	UDINT [4]	File system statistic: <ul style="list-style-type: none"> ● Word 1: Total size ● Word 2: Free space size ● Word 3: Used space size ● Word 4: Bad Space size

⁽¹⁾ Not accessible through the application.

Generic PLC Setup (read - write)

Modbus Address ⁽¹⁾	Identification	Type	Comments
62000	OPEN PLC CONTROL	UINT	When value pass from 0 to 6699, the value previously written in the following %MW62001 is considered.
62001	SET PLC CONTROL	WORD	Command take in account only on value %MW62000 change from 0 to 6699: <ul style="list-style-type: none"> ● 1: STOP ● 2: RUN ● 4: RESET COLD ● 8: RESET WARM ● 10: RESET ORIGIN ● Other: No change
62002	FILECHECKSUM_CMD	WORD	Checksum file command: <ul style="list-style-type: none"> ● 0: Idle. ● 66 then 01 hex: Ask for the checksum of the file (<i>sys/firmware.bin</i>). Keep this value until the end of the calculation. ● 66 then 02 hex: Ask for the checksum of the file (<i>sys/DefWebSrv.bin</i>). Keep this value until the end of the calculation. ● F1 hex: End for the checksum process of the file (<i>sys/firmware.bin</i>), value into the 2 next addresses. ● F2 hex: End for the checksum process of the file (<i>DefWebSrv.bin</i>), value into the 2 next addresses. ● E0 hex: Detected error on process due to file missing or wrong command.

Modbus Address⁽¹⁾	Identification	Type	Comments
62003	FILECHECKSUM_H	WORD	File checksum HIGH word (checksum is an addition of 32 bits value).
62004	FILECHECKSUM_L	WORD	File checksum LOW word (checksum is an addition of 32 bits value).
⁽¹⁾ Not accessible through the application.			

Ethernet Setup (read - write)

Modbus Address ⁽¹⁾	Identification	Type	Comments
62050	NVMEMORY_IP_ADDR	BYTE (4)	IP address configuration (taken into account after power-cycling).
62052	NVMEMORY_IP_SUBMASK	BYTE (4)	Subnet mask configuration (taken into account after power-cycling).
62054	NVMEMORY_IP_GATEWAY	BYTE (4)	Gateway address (taken into account after power-cycling).
62056	NVMEMORY_DEVICENAME	STRING [16]	DeviceName configuration (taken into account after power-cycling).
62064	NVMEMORY_BOOTUP_MODE_SETTINGS	WORD	Bootup mode configuration (taken into account after power-cycling): <ul style="list-style-type: none"> ● 0: DHCP ● 1: BootP ● 2: Stored ● FF: Default IP
62065	NVMEMORY_ENABLE_WEB_MAIL	WORD	Ethernet functionalities configuration (default value: 5): <ul style="list-style-type: none"> ● Bit 0: Web server activation ● Bit 1: E-mail activation (email not implemented) ● Bit 2: Modbus/TCP activation (not managed) ● Bit 3: FTP activation ● Bit 4: SoMachine activation ● Bit 5: NetManage activation
62066	RESET_ALL_COUNTERS	WORD	From 0 to 1 reset all counters. To reset again, it is necessary to re-write this register to 0 before set to 1 again.
62067	NVMEMORY_ETH_PARAM_APP_ENABLE	WORD	<ul style="list-style-type: none"> ● 1: Enable the update of Ethernet parameters by the SoMachine application at startup and at download. ● 0: Ethernet parameters of the SoMachine application not taken into account. <p>When you set it from 0 to 1, the Ethernet parameters are also updated by application parameters.</p>
⁽¹⁾ Not accessible through the application.			

Chapter 14

ATV IMC Web Server

Introduction

This chapter describes how to access the ATV IMC Web Server.

You can view these pages by installing the module and configuring its IP address.

What Is in This Chapter?

This chapter contains the following topics:

Topic	Page
Web Server	104
Monitoring Page	108
Diagnostics Page	113
Setup Page	114
Documentation Page	118

Web Server

Introduction

The controller provides as standard an embedded Web server with a predefined factory built-in website. You can use the pages of the website for module setup and control as well as application diagnostic and monitoring. They are 'ready to use' using a simple Web browser. No configuration or programming is required.

The Web server can be accessed by the navigators listed below:

- Microsoft Internet Explorer (version 6.0 or higher)
- Mozilla Firefox (version 1.5 or higher)

NOTE: The Web server can be disabled by setting the **Web Server active** parameter in the Ethernet Configuration (*see page 81*) tab.

The Web server is limited to 6 simultaneous HTTP connections .

The Web server is a tool for reading and writing data, and control the state of the controller, with full access to all data in your application. If, however, there are security concerns over these functions, you must at a minimum assign a secure password to the Web Server or disable the Web Server to prevent unauthorized access to the application. By enabling the Web server, you enable these functions.

For reasons of security for your installation, you must immediately upon first log in change the default password.

WARNING

UNAUTHORIZED DATA ACCESS

- Immediately change the default password to a new, secure password.
- Do not distribute the password to unauthorized or otherwise unqualified personnel.
- Disable the Web server to prevent any unwanted or unauthorized access to data in your application.

Failure to follow these instructions can result in death, serious injury, or equipment damage.

NOTE: A secure password is one that has not been shared or distributed to any unauthorized personnel and does not contain any personal or otherwise obvious information. Further, a mix of upper and lower case letters and numbers offer the greatest security possible. You should chose a password length of at least 7 characters.

NOTE: Schneider Electric follows, and recommends to its customers, industry best practices in the development and implementation of control systems. This recommendation includes a "Defense-in-Depth" approach to secure an Industrial Control System. This approach places the controllers behind one or more firewalls to restrict access to authorized personnel and protocols only.

WARNING

UNAUTHENTICATED ACCESS AND SUBSEQUENT UNAUTHORIZED MACHINE OPERATION

- Evaluate whether your environment or your machines are connected to your critical infrastructure and, if so, take appropriate steps in terms of prevention, based on Defense-in-Depth, before connecting the automation system to any network.
- Limit the number of devices connected to a network to the minimum necessary.
- Isolate your industrial network from other networks inside your company.
- Protect any network against unintended access by using firewalls, VPN, or other, proven security measures.
- Monitor activities within your systems.
- Prevent subject devices from direct access or direct link by unauthorized parties or unauthenticated actions.
- Prepare a recovery plan including backup of your system and process information.

Failure to follow these instructions can result in death, serious injury, or equipment damage.

Web Server Pages

The following table gives you an overview of the Web Server pages:

Menu	Page	Description
Home	Home	Allow login and password enter.
Monitoring	IMC Viewer	<ul style="list-style-type: none"> ● Device Name: shows the name of the device ● Controller: shows the controller state ● CANopen: shows the state of the CANopen master ● Drive: shows the state of the drive ● logical inputs and outputs ● analog inputs and outputs
	Data parameters	Display and modification of controller variables.
	Oscilloscope	Display of two variables in the form of a recorder type time chart.
Diagnostics	Ethernet statistics	Provides information about: <ul style="list-style-type: none"> ● Emission statistics ● Reception statistics ● Detected errors

Menu	Page	Description
Setup	Ethernet Setup	This page is used to setup the Ethernet connection.
	Security	Provides 3 types of passwords: <ul style="list-style-type: none"> ● Monitor password ● Data write password ● Administrator password
Documentation	References	Link to www.schneider-electric.com

Page Access

This table describes the controller status necessary to access to the pages:

Menu	Page	Controller Status			
		Empty	Stopped	Running	Stop on detected error
Home	Home	X	X	X	X
Monitoring	IMC Viewer	X	X	X	X
	Data parameters	-	X	X	-
	Oscilloscope	-	X	X	-
Setup	Ethernet Setup	X	X	X	X
	Security	X	X	X	X
Diagnostics	Ethernet Statistics	X	X	X	X
Control	Control	X	X	X	X
Documentation	References	X	X	X	X
Maintenance	Maintenance	X	X	X	X

Home Page Access

To access to the website home page, type the IP address of the controller in your navigator or 90.0.0.1 via USB:

Altivar™ Integrated Machine Controller®

Home | Documentation | Monitoring | Control | Diagnostics | Maintenance | Setup | URL

Web site version : 1.1.0.1
Copyright © 1998 - 2009, Schneider Electric. All Rights Reserved.

NOTE: To access the home page, enter a valid password.

The default user names and passwords are:

- Administration: ADMIN / ADMIN
- Monitor: USER / USER

NOTE: Verify that the port 502 is open in the Ethernet network.

Monitoring Page

Monitoring Page

The page **Monitoring** allows you to access the following services:

- **IMC Viewer**
- **Data Parameters**
- **Oscilloscope**

IMC Viewer Page

Click on **IMC Viewer** to view the following page:

The screenshot shows the Schneider Electric Altivar™ Integrated Machine Controller® Monitoring page. The interface includes a navigation menu on the left with options: Monitoring, IMC viewer, Data parameters, and Oscilloscope. The main content area is titled 'Monitoring' and contains the following information:

- Device Name:** myDevice
- Controller:** RUNNING
- CANopen:** Operational
- Drive:** NLP
- Analog Inputs (AI):**
 - AI51: 0.019 mA
 - AI52: 0.019 mA
- Analog Outputs (AO):**
 - AO51: 0.0 mA
 - AO52: 0.0 mA

Below the data, there is a copyright notice: © 2009 Schneider Electric. All Rights Reserved.

On the left-hand side, you can see the state of the **Controller** and the logical IOs.

On the right-hand side, you can see the state of the **CANopen** master and the local **Drive** as well as the analog IOs.

Data Parameters

Monitoring variables in the Web Server

To monitor variables in the web server, you should add a **Web Data Configuration** object to your project. Within this object, you can select all variables you want to monitor.

This table describes how to add a **Web Data Configuration** object:

Step	Action
1	Right click the Application node in the Applications tree tab.
2	Click Add Object → Web Data Configuration... Result: The Add Web Data Configuration window is displayed.
3	Click Add . Result: The Web Data Configuration object is created and the Web Data Configuration editor is open. NOTE: As a Web Data Configuration object is unique for a controller, its name cannot be changed.

Web Data Configuration Editor

Click the **Refresh** button to be able to select variables, this action will display all the variables defined in the application.

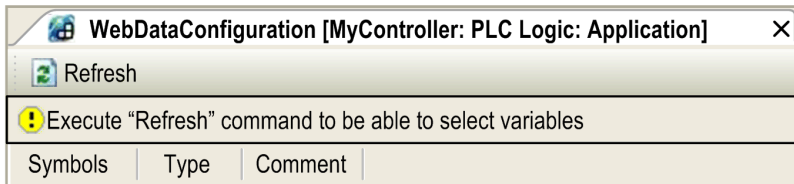

Select the variables you want to monitor in the web server:

WebDataConfiguration [MyController: PLC Logic: Application] X

Refresh

Symbols	Type	Comment
<input checked="" type="checkbox"/> ixDI_I0 (%IX0.0)	Bool	DI : Fast input, Sink/Source
<input type="checkbox"/> ixDI_I1 (%IX0.1)	Bool	DI : Fast input, Sink/Source
<input type="checkbox"/> ixDI_I2 (%IX0.2)	Bool	DI : Fast input, Sink/Source
<input type="checkbox"/> ixDI_I3 (%IX0.3)	Bool	DI : Fast input, Sink/Source
<input type="checkbox"/> ixDI_I4 (%IX0.4)	Bool	DI : Fast input, Sink/Source
<input type="checkbox"/> ixDI_I5 (%IX0.5)	Bool	DI : Fast input, Sink/Source
<input checked="" type="checkbox"/> ixDI_I6 (%IX0.6)	Bool	DI : Fast input, Sink/Source
<input type="checkbox"/> ixDI_I7 (%IX0.7)	Bool	DI : Fast input, Sink/Source
<input type="checkbox"/> ixDI_I8 (%IX1.0)	Bool	DI : Regular input, Sink/Source
<input type="checkbox"/> ixDI_I9 (%IX1.1)	Bool	DI : Regular input, Sink/Source
<input type="checkbox"/> ixDI_I10 (%IX1.2)	Bool	DI : Regular input, Sink/Source
<input type="checkbox"/> ixDI_I11 (%IX1.3)	Bool	DI : Regular input, Sink/Source
<input type="checkbox"/> ixDI_I12 (%IX1.4)	Bool	DI : Regular input, Sink/Source
<input type="checkbox"/> ixDI_I13 (%IX1.5)	Bool	DI : Regular input, Sink/Source
<input type="checkbox"/> ixDI_I0_1 (%IX2.0)	Bool	DI : Short Circuit detected (if True)
<input type="checkbox"/> qxDQ_Q0 (%QX0.0)	Bool	DQ : Fast output, Push/pull
<input type="checkbox"/> qxDQ_Q1 (%QX0.1)	Bool	DQ : Fast output, Push/pull
<input checked="" type="checkbox"/> qxDQ_Q2 (%QX0.2)	Bool	DQ : Fast output, Push/pull
<input checked="" type="checkbox"/> qxDQ_Q3 (%QX0.3)	Bool	DQ : Fast output, Push/pull
<input type="checkbox"/> qxDQ_Q4 (%QX0.4)	Bool	DQ : Regular output
<input type="checkbox"/> qxDQ_Q5 (%QX0.5)	Bool	DQ : Regular output
<input type="checkbox"/> qxDQ_Q6 (%QX0.6)	Bool	DQ : Regular output
<input type="checkbox"/> qxDQ_Q7 (%QX0.7)	Bool	DQ : Regular output
<input type="checkbox"/> qxDQ_Q8 (%QX1.0)	Bool	DQ : Regular output
<input checked="" type="checkbox"/> qxDQ_Q9 (%QX1.1)	Bool	DQ : Regular output
<input type="checkbox"/> qxDQ_Q0_1 (%QX2.0)	Bool	DQ : Rearming Command (on rising edge)
<input type="checkbox"/> qxModule_2_Q0 (%QX4.0)	Bool	Module_2 :
<input type="checkbox"/> qxModule_2_Q1 (%QX4.1)	Bool	Module_2 :
<input type="checkbox"/> qxModule_2_Q2 (%QX4.2)	Bool	Module_2 :
<input type="checkbox"/> qxModule_2_Q3 (%QX4.3)	Bool	Module_2 :
<input type="checkbox"/> qxModule_2_Q4 (%QX4.4)	Bool	Module_2 :
<input type="checkbox"/> qxModule_2_Q5 (%QX4.5)	Bool	Module_2 :
<input type="checkbox"/> qxModule_2_Q6 (%QX4.6)	Bool	Module_2 :
<input type="checkbox"/> qxModule_2_Q7 (%QX4.7)	Bool	Module_2 :
<input type="checkbox"/> qxModule_2_Q8 (%QX5.0)	Bool	Module_2 :
<input type="checkbox"/> qxModule_2_Q9 (%QX5.1)	Bool	Module_2 :
<input type="checkbox"/> qxModule_2_Q10 (%QX5.2)	Bool	Module_2 :
<input type="checkbox"/> qxModule_2_Q11 (%QX5.3)	Bool	Module_2 :
<input type="checkbox"/> qxModule_2_Q12 (%QX5.4)	Bool	Module_2 :
<input type="checkbox"/> qxModule_2_Q13 (%QX5.5)	Bool	Module_2 :
<input type="checkbox"/> qxModule_2_Q14 (%QX5.6)	Bool	Module_2 :
<input type="checkbox"/> qxModule_2_Q15 (%QX5.7)	Bool	Module_2 :
<input checked="" type="checkbox"/> GVL	Int	
<input checked="" type="checkbox"/> count	Int	

NOTE: The variable selection is possible only in offline mode.

Data parameters page

The page **Data parameters** enables to display and modify variables and values.

Click on **Data parameter** to view the following page:

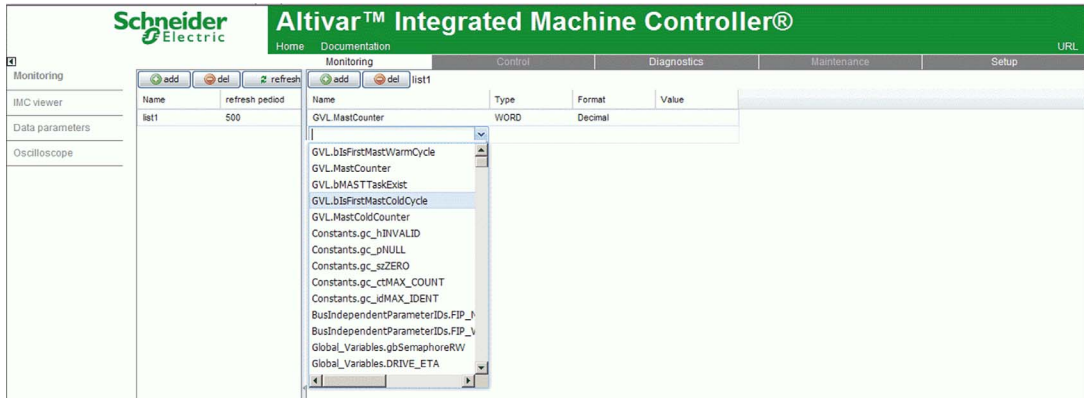

Element	Description
load	Load a list description.
save	Save the list description in the controller (<i>/usr/web</i> directory).
add	Add a list description or a variable.
del	Delete a list description or a variable.
refresh	Refresh the variables.

NOTE: Modifying variable through **Data parameters** page requires the **Data write password** (default: USER).

IEC object (%IW, %M,...) are not accessible.

Oscilloscope Page

The oscilloscope page allows to display two variables in the form of a recorder time chart:

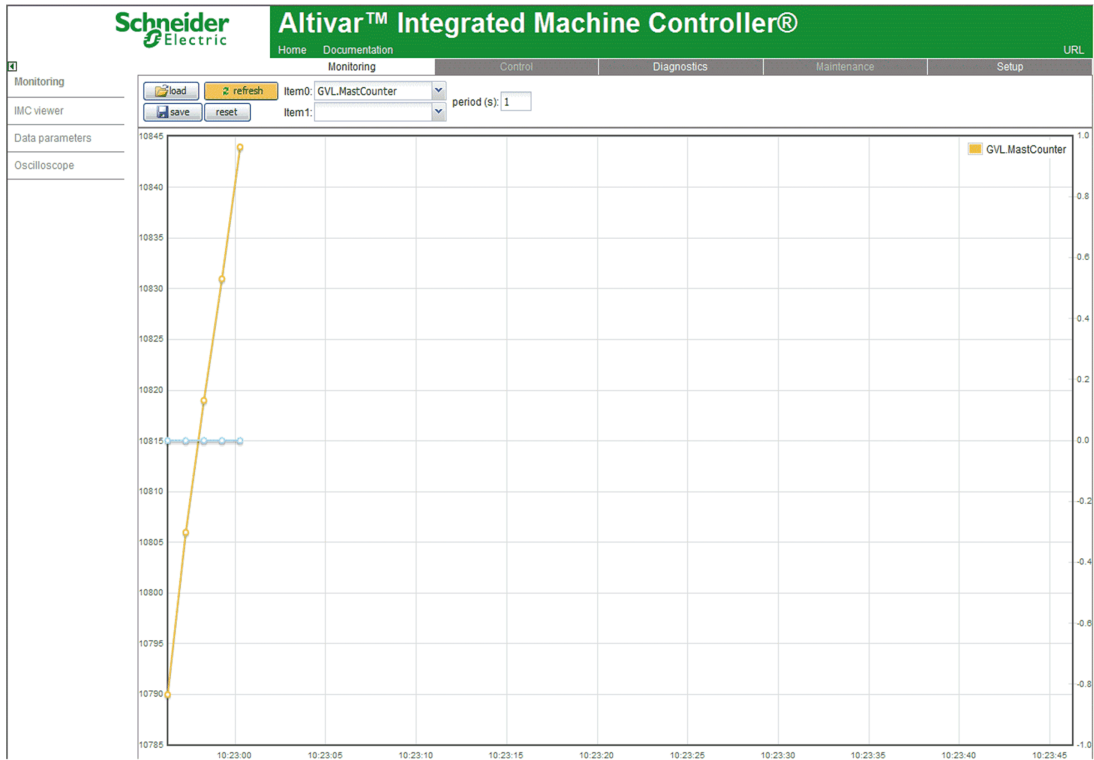

Element	Description
reset	Erase the memorization.
refresh	Start/stop refreshing.
load	Load parameters configuration of Item0 and Item1.
save	Save parameters configuration of Item0 and Item1 in the controller.
Item0	Variable to be displayed.
Item1	Variable to be displayed.
Period (s)	Page refresh period in second.

Diagnostics Page

Diagnostics Page

The Web Server page **Diagnostics** is an Ethernet Statistics page and provides information about:

- Emission statistics
- Reception statistics
- Detected errors

Click **Diagnostics** and then **Ethernet Statistics** to view the following page:

Schneider Electric **Altivar™ Integrated Machine Controller®**

Home Documentation URL

Monitoring Control **Diagnostics** Maintenance Setup

Device Name	myDevice	Status	Not connected
MAC Address	00-80-F4-80-58-59	Device Type	Altivar IMC
IP Address	0.0.0.0	Device Reference	VW3A3521S0
NetMask	0.0.0.0	Software Version	v1.0ie20
Gateway	0.0.0.0	IP Configuration	Default

Emission statistics		Reception statistics		Other errors	
Emissions	<input type="text"/>	Receptions	<input type="text"/>	Collisions	<input type="text"/>
Deferred Emissions	<input type="text"/>	CRC Errors	<input type="text"/>	Multi Collisions	<input type="text"/>
Late Collisions	<input type="text"/>	Frame Errors	<input type="text"/>	Over Run	<input type="text"/>
Buffer Errors	<input type="text"/>	Buffer Errors	<input type="text"/>		
Emission Messages	<input type="text"/>	Reception Messages	<input type="text"/>	Error Messages	<input type="text"/>
IO Scan Emissions	<input type="text"/>	IO Scan Receptions	<input type="text"/>	IO Scan Errors	<input type="text"/>
Traffic (msg/s)	<input type="text"/>	Max. Traffic (msg/s)	<input type="text"/>	Connections (X02)	<input type="text"/>

© 2009 Schneider Electric. All Rights Reserved.

Setup Page

Setup Page

The **Setup** page enables you to change entries regarding:

- **Ethernet**
- **Security** including
 - **Monitor password**
 - **Data write password**
 - **Administrator password**

Ethernet Setup

Click **Ethernet** to open the following page:

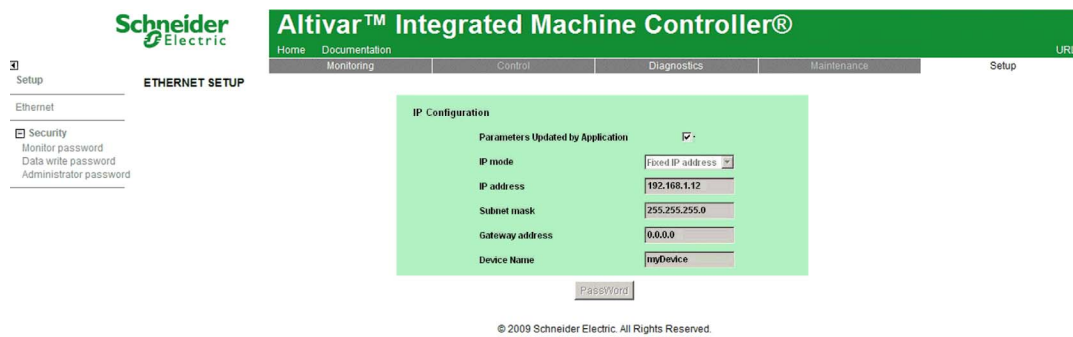

The Ethernet parameters defined by the web page are taken into account only if there is no SoMachine application.

Click **Password** to update the Ethernet parameters.

NOTE:

- The **Data write password** is required to update these parameters.
- When you enable the **Parameters Updated by Application** field, the parameters are modified by the boot application (if available), and you cannot manually change them into the webpage.

Monitor Security

Click **Security** and **Monitor password** to open the following page:

The screenshot shows the 'Monitor security' page in the Altivar™ Integrated Machine Controller web interface. The page features a green header with the product name and a navigation menu. A left sidebar shows a tree view with 'Security' expanded to 'Monitor password'. The main content area contains two forms: one for changing the password and one for changing the username. Each form has fields for 'Current', 'New', and 'Confirm' values, followed by a 'Change' button. A copyright notice '© 2009 Schneider Electric. All Rights Reserved.' is at the bottom.

Changing the Monitor Password

The password is case sensitive and can be a mix of up to 20 alphanumeric characters (a...Z, 0...9).

If you have lost or forgotten the password, connect to the administration account to retrieve the password. After doing so, set up a new, secure password.

NOTE: A secure password is one that has not been shared or distributed to any unauthorized personnel and does not contain any personal or otherwise obvious information. Further, a mix of upper and lower case letters and numbers offer the best security possible. Choose a password length of at least 7 characters.

To change the monitor password, proceed as follows:

Step	Action
1	Enter the current Username (Default user name and password: USER / USER).
2	Enter new password.
3	Confirm the new password.
4	Confirm the change by clicking Change Password . Result: a confirmation window appears.

To change the monitor username, proceed as follows:

Step	Action
1	Enter the current Username .
2	Enter new username.
3	Confirm the new username.
4	Confirm the change by clicking Change Username . Result: a confirmation window appears.

Setup Security

Click **Security** and **Data write password** to open the following page:

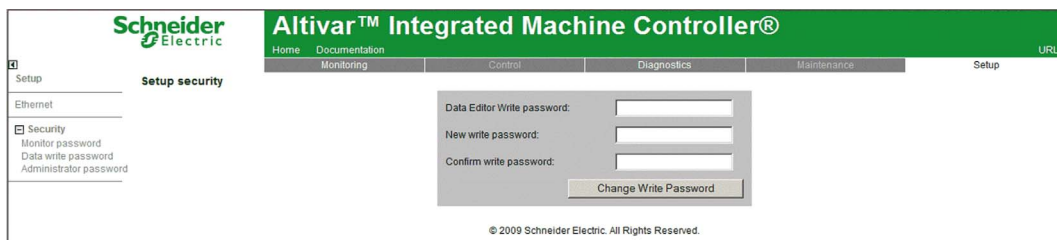

Changing the Data Write Password

The password is case sensitive and can be a mix of up to 20 alphanumeric characters (a...Z, 0...9).

If you have lost or forgotten the password, connect to the administration account to retrieve the password. After doing so, set up a new, secure password.

NOTE: A secure password is one that has not been shared or distributed to any unauthorized personnel and does not contain any personal or otherwise obvious information. Further, a mix of upper and lower case letters and numbers offer the best security possible. Choose a password length of at least 7 characters.

To change the data write password, proceed as follows:

Step	Action
1	Enter the current Data Editor Write password (Default user name and password: USER / USER).
2	Enter new write password.
3	Confirm the new write password.
4	Confirm the change by clicking Change Write Password . Result: a confirmation window appears.

Administrator Security

Click **Security** and **Administrator password** to open the following page:

The **Reset all user rights** button resets all usernames/passwords that have been changed to their default values.

Changing the Administrator Password

The password is case sensitive and can be a mix of up to 20 alphanumeric characters (a...Z, 0...9).

If you have lost or forgotten the password, it is not possible to retrieve it, so you need to contact your local Schneider distributor for support. After doing so, set up a new, secure password.

NOTE: A secure password is one that has not been shared or distributed to any unauthorized personnel and does not contain any personal or otherwise obvious information. Further, a mix of upper and lower case letters and numbers offer the best security possible. Choose a password length of at least 7 characters.

To change the administrator password, proceed as follows:

Step	Action
1	Enter the current Password (Default user name and password: ADMIN / ADMIN).
2	Enter the new password.
3	Confirm the new password.
4	Confirm the change by clicking Change Admin Password . Result: a confirmation window appears.

Documentation Page

Documentation

This page provides a link to **References** of Schneider Electric .

Click on **Documentation** to open the following page:



The screenshot shows the web interface for the Altivar™ Integrated Machine Controller. At the top left is the Schneider Electric logo. The main header is green with the text "Altivar™ Integrated Machine Controller®". Below the header is a navigation bar with tabs: Home, Documentation (selected), Monitoring, Control, Diagnostics, Maintenance, Setup, and URL. On the left side, there is a sidebar menu with "Documentation" and "References". Under "References", there is a link to "Schneider Electric". The main content area displays "REFERENCES" followed by the link "Schneider Electric". At the bottom of the page, there is a copyright notice: "© 2009 Schneider Electric. All Rights Reserved."

Chapter 15

CANopen

CANopen Interface Configuration

CAN Bus Configuration

To configure the **CAN** bus of your controller, proceed as follows:

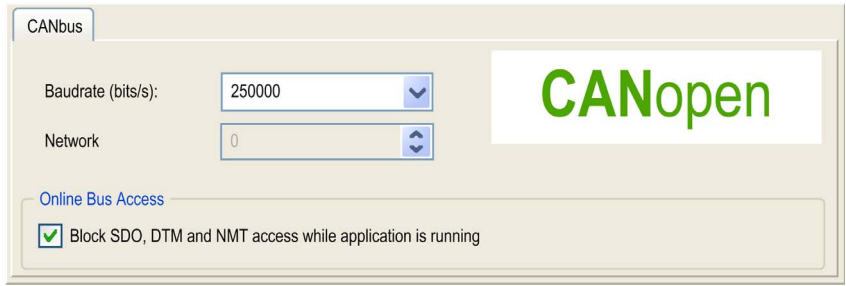
Step	Action
1	In the Devices tree , double-click CAN .
2	Configure the baudrate (by default: 250000 bits/s):  NOTE: The Online Bus Access option allows you to block SDO, DTM, and NMT sending through the status screen.

CANopen Manager Creation and Configuration

If the **CANopen Manager** is not already present below the **CAN** node, proceed as follows to create and configure it:

Step	Action
1	Select CANopen Optimized in the Hardware Catalog , drag it to the Devices tree , and drop it on one of the highlighted nodes. For more information on adding a device to your project, refer to: <ul style="list-style-type: none">• Using the Drag-and-Drop Method (see <i>SoMachine, Programming Guide</i>)• Using the Contextual Menu or Plus button (see <i>SoMachine, Programming Guide</i>)

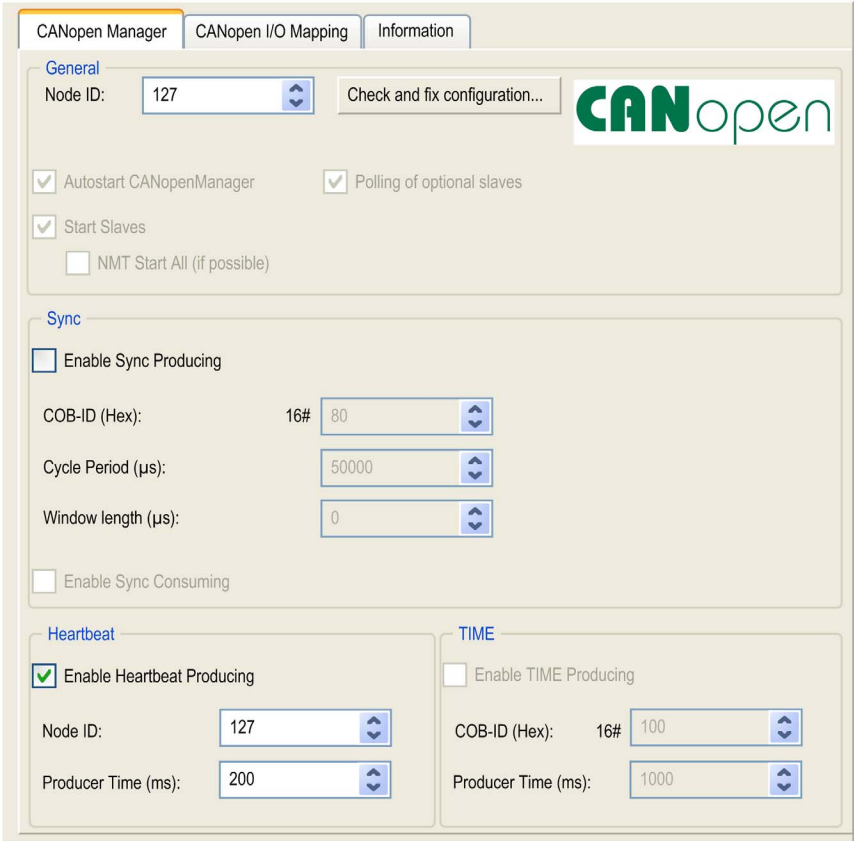
Step	Action
2	<p>Double-click CANopen_Optimized. Result: The CANopen Manager configuration window appears:</p> 

Adding a CANopen Device

Refer to the SoMachine Programming Guide for more information on Adding Communication Managers and Adding Slave Devices to a Communication Manager.

CANopen Operating Limits

The Altivar ATV IMC Drive Controller CANopen master has the following operating limits:

Maximum number of slave devices	16
Maximum number of Received PDO (RPDO)	32
Maximum number of Transmitted PDO (TPDO)	32

WARNING

UNINTENDED EQUIPMENT OPERATION

- Do not connect more than 16 CANopen slave devices to the controller.
- Program your application to use 32 or fewer Transmit PDO (TPDO).
- Program your application to use 32 or fewer Receive PDO (RPDO).

Failure to follow these instructions can result in death, serious injury, or equipment damage.

Chapter 16

Connecting ATV IMC to a PC

Connecting the Altivar ATV IMC Drive Controller to a PC

Introduction

To transfer and run applications, connect the Altivar ATV IMC Drive Controller to a PC with a properly installed version of SoMachine.

You can connect the Altivar ATV IMC Drive Controller to the PC by means of two different ways:

- USB-cable
- Ethernet connection

NOTE: To use the communication ports of the PC, stop the CoDeSys gateway by right-clicking the CoDeSys Gateway SysTray (running) icon from the taskbar and selecting the command Stop Gateway. This is mandatory if you want to use the Ethernet cable.

The communication cable should be connected to the PC first to minimize the possibility of electrostatic discharge affecting the controller.

<i>NOTICE</i>

INOPERABLE EQUIPMENT

Always connect the communication cable to the PC before connecting it to the controller.
--

Failure to follow these instructions can result in equipment damage.

NOTE: Only 1 controller should be connected to a computer at any given time. Do not connect multiple controllers simultaneously.

Connecting Through Ethernet

The following illustration describes the Ethernet connection:

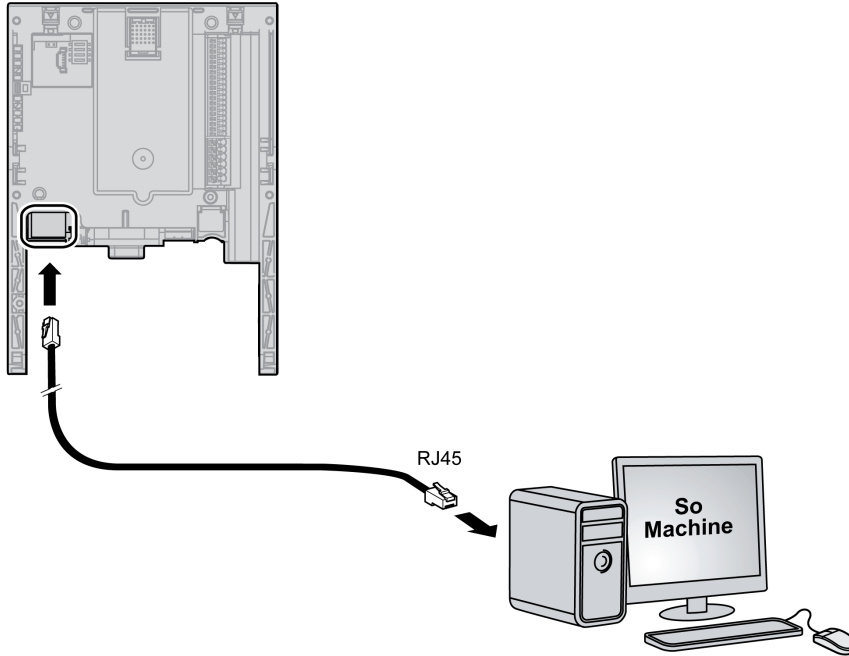

Please proceed as follows to connect the controller to the PC:

Step	Action
1	First connect the cable to the PC.
2	Then connect the cable to the controller.

The following illustration describes the Ethernet connection with a HUB:

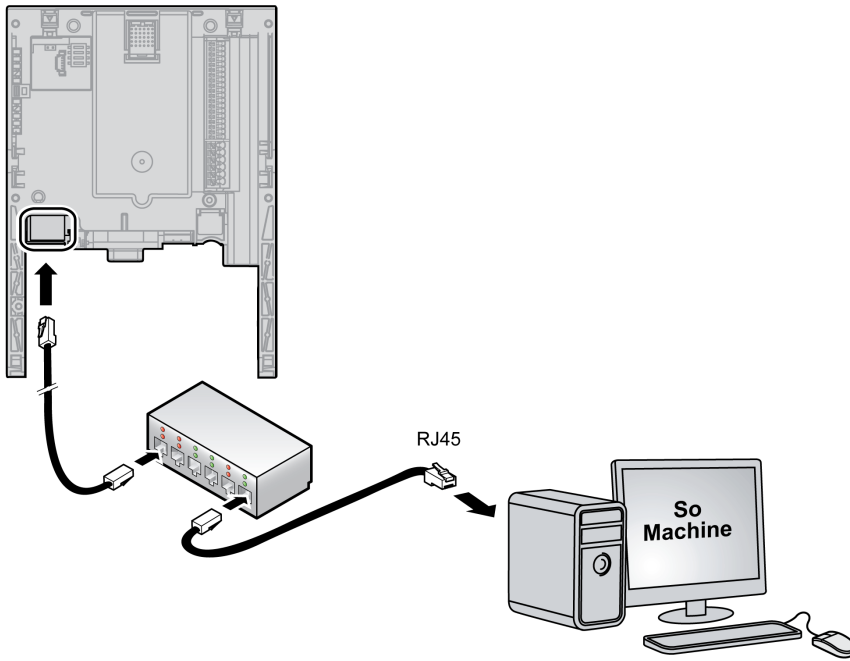

Connecting Through USB

The following illustration describes the Mini USB connection:

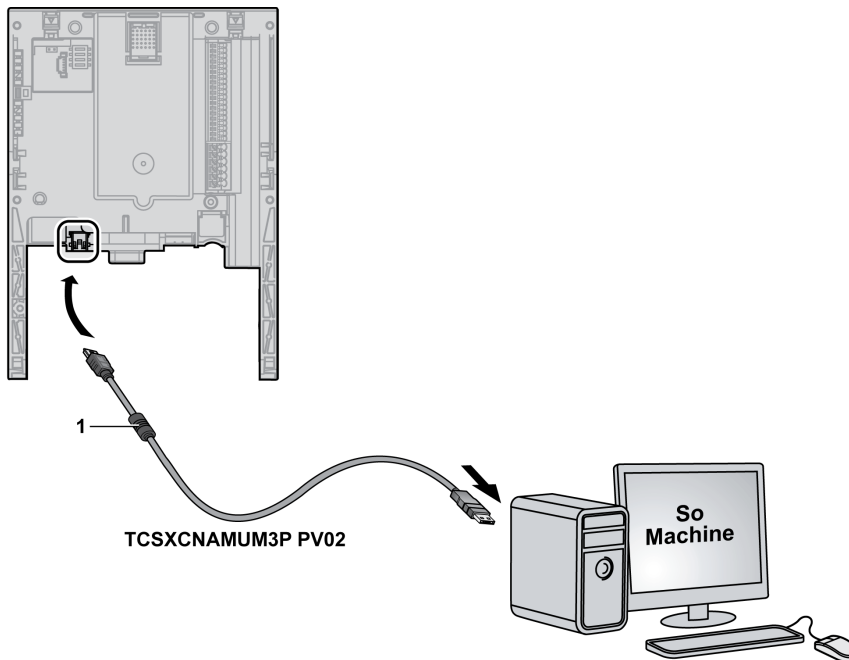

1 Ferrite

NOTICE

INOPERABLE EQUIPMENT

- Only use the USB cable TCSXCNAMUM3P PV02 (with ferrite).
- Do not use a USB cable extension.
- In case of high power drive, disconnect the PC from the ground and verify the ground connection between the drive and the motor.
- Always connect the communication cable to the PC before connecting it to the controller.

Failure to follow these instructions can result in equipment damage.

NOTE: High Power Drive references are ATV71H•••N4 or ATV61H•••N4 ≥ 90 kW (125HP) and ATV71H•••Y or ATV61H•••Y ≥ 110 kW (150HP).

Access to the Control Terminals

To access the control terminals proceed as follows:

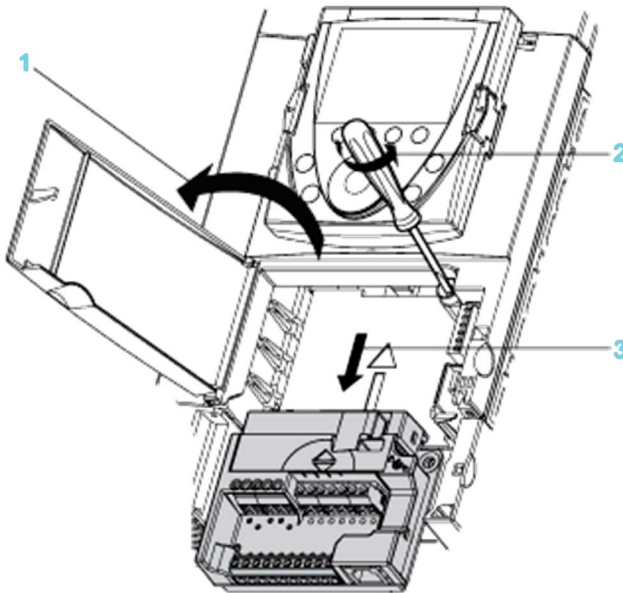

Remove power before opening the cover on the control front panel.

Step	Action
1	To access the control terminals, open the cover on the control front panel. To make it easier to wire the drive control section, the control terminal card can be removed.
2	Loosen the screw until the spring is fully extended.
3	Remove the the card by sliding it downwards. Maximum wire size: 2.5 mm ² - AWG 14 Max. tightening torque: 0.6 Nm - 5.3 lb-in

⚠ WARNING

UNSECURED TERMINAL CARD

Fully tighten the captive-screw to a torque value of 1.1...1.7 Nm (9.7...15 lb-in) after replacing the control terminal card.

Failure to follow these instructions can result in death, serious injury, or equipment damage.

Chapter 17

Changing the ATV IMC Firmware

Overview

The firmware of the Altivar ATV IMC Drive Controller can be changed using:

- *ATVIMC_Firmware_Loader_V1.0.exe* software
- SoMachine Central

What Is in This Chapter?

This chapter contains the following topics:

Topic	Page
Changing the Altivar ATV IMC Drive Controller Firmware with <i>ATVIMC_Firmware_Loader_V1.0.exe</i>	130
Changing the Altivar ATV IMC Drive Controller firmware with SoMachine Central	133

Changing the Altivar ATV IMC Drive Controller Firmware with `ATVIMC_Firmware_Loader_V1.0.exe`

Introduction

You can find the executable file in the folder `...\Schneider Electric\SoMachine Software\Vx.y\LogicBuilder\Firmware\Tools\ATV-IMC\` in your local SoMachine installation folder.

By default, the location is `C:\Program Files\Schneider Electric\SoMachine`.

The latest firmware updates for the Altivar ATV IMC Drive Controller are available on the <http://www.schneider-electric.com> website (zip format).

Unzip the file on your local computer. Each firmware version zip file contains the `FmwUpgrade.exe` software and the firmware files.

Changing the Firmware

Perform the steps in the following table to change the Altivar ATV IMC Drive Controller:

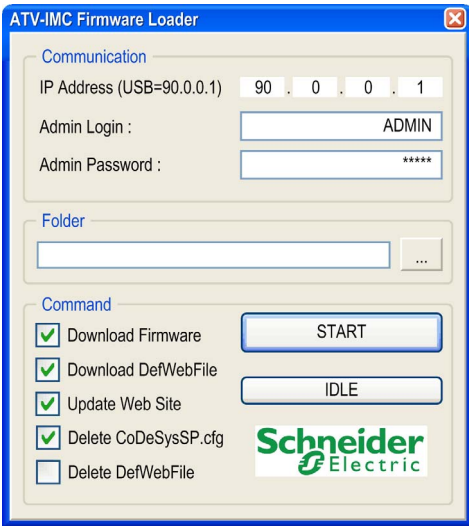
Step	Action
1	Connect the Altivar ATV IMC Drive Controller to the PC through an USB cable (see page 123).
2	Power on the Altivar ATV IMC Drive Controller.
3	Wait until the connection between PC and Altivar ATV IMC Drive Controller is established.
4	<p>Launch <code>ATVIMC_Firmware_Loader_V1.0.exe</code>.</p> 

Step	Action
5	Configure the communication (Refer to Communication description (see page 131)).
6	Select the commands requested during the upgrade (Refer to Commands description (see page 131)).
7	Click START .
8	Wait until the indication Please Reset Device appears.
9	Power off and then power on the Altivar ATV IMC Drive Controller.

Communication

Parameter	Description
IP Address	If you are not using the USB cable, access the Altivar ATV IMC Drive Controller through Ethernet. In the IP Address (USB = 90.0.0.1) box, type the current IP address of the Altivar ATV IMC Drive Controller. By default, the IP address is 90.0.0.1.
Admin Login	Type the current administrator login. By default, the login is ADMIN .
Admin Password	Type the current administrator password. By default, the password is ADMIN .

NOTE: Upgrades are not possible if the administrator login / password are incorrect.

Folder

Lets you browse for the location of the binary and web server file of the firmware.

You can find the firmware file in the folder `\Firmware\ATV-IMC\Vx.y.z.t` in your local SoMachine installation folder, where:

`Vx.y.z.t` is version of the Altivar ATV IMC Drive Controller firmware.

Command

After clicking **START**, the selected commands are realized one after the other.

Action	Description
Download Firmware	This action copies the firmware files from the local PC to the controller file-system disk. The files contain the firmware information.
Download DefWebFile	This action copies the file (<i>DefWebSrv.bin</i>) from the local PC to the controller file-system disk. The file contains all the files necessary to upgrade the entire web site.

Action	Description
Update Web Site	This action updates the entire web site from the current file <i>DefWebSrv.bin</i> present in the Altivar ATV IMC Drive Controller file-system. This command will not run if the firmware is not present. NOTE: Empty your Internet web browser cache after using this command.
Delete CodeSysSp.cfg	This action deletes the file (<i>CodeSysSp.cfg</i>) from the controller file-system disk. The file contains several parameters for the application, as the current application used or the RUN command at start-up. During the start-up of the Altivar ATV IMC Drive Controller, if this file is missing, a default one is created with the default application parameters.
Delete DefWebFile	This action deletes the file (<i>DefWebSrv.bin</i>) from the controller file-system disk. NOTE: The file <i>DefWebSrv.bin</i> takes a lot of space in the controller; hence, it is recommended to delete it after performing the Update Web Site command.

Diagnostic

After clicking **START**, the indicator below **START** shows the current status in the Altivar ATV IMC Drive Controller.

The following events can occur:

Detected error	Description
Connection failed	Device cannot be accessed on the specified address.
Send Firmware Failed	The download is unsuccessful; this can occur for example if there is a communication interruption, or if the Altivar ATV IMC Drive Controller file system is full.
Send DefWebFile Failed	The download is unsuccessful; this can occur for example if there is a communication interruption, or if the Altivar ATV IMC Drive Controller file system is full.
DefWebFile not found	The file <i>DefWebSrv.bin</i> in the Altivar ATV IMC Drive Controller file-system is missing.
Wrong Login/Password	The login or password is incorrect.
Delete CoDeSysSP Failed	The file <i>DefWebSrv.bin</i> in the Altivar ATV IMC Drive Controller file-system is missing.
File missing	The files for the update is missing.

Changing the Altivar ATV IMC Drive Controller firmware with SoMachine Central

Changing the Altivar ATV IMC Drive Controller Firmware with the SoMachine Central

Step	Action
1	<ul style="list-style-type: none"> ● Double-click the SoMachine Central icon on your desktop or ● Click Start → Programs → Schneider Electric → SoMachine Software → Vx.y. <p>Result: The SoMachine Central Get started screen is displayed.</p>
2	<p>Click Maintenance button.</p>
3	<p>Select Download Firmware ATV-IMC as shown below:</p>  <p>Result: The ATV-IMC Firmware Loader window appears. For more information, refer to Changing the Firmware (see page 130).</p>

Chapter 18

Compatibility

Software and Firmware Compatibilities

SoMachine Compatibility and Migration

Software and Firmware compatibilities are described in the SoMachine Compatibility and Migration User Guide.

Glossary



A

AMOA

Drive parameter that contains the Modbus address of the ATV IMC drive controller.

analog input

Converts received voltage or current levels into numerical values. You can store and process these values within the logic controller.

analog output

Converts numerical values within the logic controller and sends out proportional voltage or current levels.

application

A program including configuration data, symbols, and documentation.

ARRAY

The systematic arrangement of data objects of a single type in the form of a table defined in logic controller memory. The syntax is as follows: `ARRAY [<dimension>] OF <Type>`

Example 1: `ARRAY [1..2] OF BOOL` is a 1-dimensional table with 2 elements of type `BOOL`.

Example 2: `ARRAY [1..10, 1..20] OF INT` is a 2-dimensional table with 10 x 20 elements of type `INT`.

ASCII

(*American standard code for Information Interchange*) A protocol for representing alphanumeric characters (letters, numbers, certain graphics, and control characters).

ATV

The model prefix for Altivar drives (for example, ATV312 refers to the Altivar 312 variable speed drive).

AWG

(*American wire gauge*) The standard that specifies wire section sizes in North America.

B

BCD

(*binary coded decimal*) The format that represents decimal numbers between 0 and 9 with a set of 4 bits (a nybble/nibble, also titled as half byte). In this format, the 4 bits used to encode decimal numbers have an unused range of combinations.

For example, the number 2,450 is encoded as `0010 0100 0101 0000`.

BOOL

(*boolean*) A basic data type in computing. A `BOOL` variable can have one of these values: 0 (`FALSE`), 1 (`TRUE`). A bit that is extracted from a word is of type `BOOL`; for example, `%MW10.4` is a fifth bit of memory word number 10.

Boot application

(*boot application*) The binary file that contains the application. Usually, it is stored in the PLC and allows PLC to boot on the application that the user has generated.

BOOTP

(*bootstrap protocol*) A UDP network protocol that can be used by a network client to automatically obtain an IP address (and possibly other data) from a server. The client identifies itself to the server using the client MAC address. The server, which maintains a pre-configured table of client device MAC addresses and associated IP addresses, sends the client its pre-configured IP address. BOOTP was originally used as a method that enabled diskless hosts to be remotely booted over a network. The BOOTP process assigns an infinite lease of an IP address. The BOOTP service utilizes UDP ports 67 and 68.

byte

A type that is encoded in an 8-bit format, ranging from `16#00` to `16#FF` in hexadecimal representation.

C

CANopen

An open industry-standard communication protocol and device profile specification (EN 50325-4).

CFC

(*continuous function chart*) A graphical programming language (an extension of the IEC 61131-3 standard) based on the function block diagram language that works like a flowchart. However, no networks are used and free positioning of graphic elements is possible, which allows feedback loops. For each block, the inputs are on the left and the outputs on the right. You can link the block outputs to the inputs of other blocks to create complex expressions.

controller

Automates industrial processes (also known as programmable logic controller or programmable controller).

D

DHCP

(*dynamic host configuration protocol*) An advanced extension of BOOTP. DHCP is more advanced, but both DHCP and BOOTP are common. (DHCP can handle BOOTP client requests.)

DINT

(*double integer type*) Encoded in 32-bit format.

DTM

(*device type manager*) Classified into 2 categories:

- Device DTMs connect to the field device configuration components.
- CommDTMs connect to the software communication components.

The DTM provides a unified structure for accessing device parameters and configuring, operating, and diagnosing the devices. DTMs can range from a simple graphical user interface for setting device parameters to a highly sophisticated application capable of performing complex real-time calculations for diagnosis and maintenance purposes.

DWORD

(*double word*) Encoded in 32-bit format.

E**encoder**

A device for length or angular measurement (linear or rotary encoders).

Ethernet

A physical and data link layer technology for LANs, also known as IEE 802.3.

F**FBD**

(*function block diagram*) One of 5 languages for logic or control supported by the standard IEC 61131-3 for control systems. Function block diagram is a graphically oriented programming language. It works with a list of networks, where each network contains a graphical structure of boxes and connection lines, which represents either a logical or arithmetic expression, the call of a function block, a jump, or a return instruction.

firmware

Represents the BIOS, data parameters, and programming instructions that constitute the operating system on a controller. The firmware is stored in non-volatile memory within the controller.

flash memory

A non-volatile memory that can be overwritten. It is stored on a special EEPROM that can be erased and reprogrammed.

freewheeling

When a logic controller is in freewheeling scan mode, a new task scan starts as soon as the previous scan has been completed. Contrast with *periodic scan mode*.

FTP

(*file transfer protocol*) A standard network protocol built on a client-server architecture to exchange and manipulate files over TCP/IP based networks regardless of their size.

function

A programming unit that has 1 input and returns 1 immediate result. However, unlike FBs, it is directly called with its name (as opposed to through an instance), has no persistent state from one call to the next and can be used as an operand in other programming expressions.

Examples: boolean (AND) operators, calculations, conversions (BYTE_TO_INT)

H

hex

(*hexadecimal*)

HMI

(*human machine interface*) An operator interface (usually graphical) for human control over industrial equipment.

I

I/O

(*input/output*)

IEC 61131-3

Part 3 of a 3-part IEC standard for industrial automation equipment. IEC 61131-3 is concerned with controller programming languages and defines 2 graphical and 2 textual programming language standards. The graphical programming languages are ladder diagram and function block diagram. The textual programming languages include structured text and instruction list.

IL

(*instruction list*) A program written in the language that is composed of a series of text-based instructions executed sequentially by the controller. Each instruction includes a line number, an instruction code, and an operand (refer to IEC 61131-3).

INT

(*integer*) A whole number encoded in 16 bits.

IP

(*Internet protocol*) Part of the TCP/IP protocol family that tracks the Internet addresses of devices, routes outgoing messages, and recognizes incoming messages.

L

LD

(*ladder diagram*) A graphical representation of the instructions of a controller program with symbols for contacts, coils, and blocks in a series of rungs executed sequentially by a controller (refer to IEC 61131-3).

LINT

(*long integer*) A whole number encoded in a 64-bit format (4 times `INT` or 2 times `DINT`).

LREAL

(*long real*) A floating-point number encoded in a 64-bit format.

LWORD

(*long word*) A data type encoded in a 64-bit format.

M**MAC address**

(*media access control address*) A unique 48-bit number associated with a specific piece of hardware. The MAC address is programmed into each network card or device when it is manufactured.

machine

Consists of several *functions* and/or *equipment*.

MAST

A processor task that is run through its programming software. The MAST task has 2 sections:

- **IN:** Inputs are copied to the IN section before execution of the MAST task.
- **OUT:** Outputs are copied to the OUT section after execution of the MAST task.

Modbus

The protocol that allows communications between many devices connected to the same network.

ms

(*millisecond*)

N**network**

A system of interconnected devices that share a common data path and protocol for communications.

NMT

(*network management*) CANopen protocols that provide services for network initialization, detected error control, and device status control.

node

An addressable device on a communication network.

O

OS

(operating system) A collection of software that manages computer hardware resources and provides common services for computer programs.

P

PDO

(process data object) An unconfirmed broadcast message or sent from a producer device to a consumer device in a CAN-based network. The transmit PDO from the producer device has a specific identifier that corresponds to the receive PDO of the consumer devices.

Profibus DP

(Profibus decentralized peripheral) An open bus system uses an electrical network based on a shielded 2-wire line or an optical network based on a fiber-optic cable. DP transmission allows for high-speed, cyclic exchange of data between the controller CPU and the distributed I/O devices.

program

The component of an application that consists of compiled source code capable of being installed in the memory of a logic controller.

R

REAL

A data type that is defined as a floating-point number encoded in a 32-bit format.

RPDO

(receive process data object) An unconfirmed broadcast message or sent from a producer device to a consumer device in a CAN-based network. The transmit PDO from the producer device has a specific identifier that corresponds to the receive PDO of the consumer devices.

RTC

(real-time clock) A battery-backed time-of-day and calendar clock that operates continuously, even when the controller is not powered for the life of the battery.

run

A command that causes the controller to scan the application program, read the physical inputs, and write to the physical outputs according to solution of the logic of the program.

S

scan

A function that includes:

- reading inputs and placing the values in memory
- executing the application program 1 instruction at a time and storing the results in memory
- using the results to update outputs

SDO

(*service data object*) A message used by the field bus master to access (read/write) the object directories of network nodes in CAN-based networks. SDO types include service SDOs (SSDOs) and client SDOs (CSDOs).

SFC

(*sequential function chart*) A language that is composed of steps with associated actions, transitions with associated logic condition, and directed links between steps and transitions. (The SFC standard is defined in IEC 848. It is IEC 61131-3 compliant.)

SINT

(*signed integer*) A 15-bit value plus sign.

ST

(*structured text*) A language that includes complex statements and nested instructions (such as iteration loops, conditional executions, or functions). ST is compliant with IEC 61131-3.

STOP

A command that causes the controller to stop running an application program.

string

A variable that is a series of ASCII characters.

T

task

A group of sections and subroutines, executed cyclically or periodically for the MAST task or periodically for the FAST task.

A task possesses a level of priority and is linked to inputs and outputs of the controller. These I/O are refreshed in relation to the task.

A controller can have several tasks.

TCP

(*transmission control protocol*) A connection-based transport layer protocol that provides a simultaneous bi-directional transmission of data. TCP is part of the TCP/IP protocol suite.

TPDO

(transmit process data object) An unconfirmed broadcast message or sent from a producer device to a consumer device in a CAN-based network. The transmit PDO from the producer device has a specific identifier that corresponds to the receive PDO of the consumer devices.

U

UDINT

(unsigned double integer) Encoded in 32 bits.

UDP

(user datagram protocol) A connectionless mode protocol (defined by IETF RFC 768) in which messages are delivered in a datagram (data telegram) to a destination computer on an IP network. The UDP protocol is typically bundled with the Internet protocol. UDP/IP messages do not expect a response, and are therefore ideal for applications in which dropped packets do not require retransmission (such as streaming video and networks that demand real-time performance).

UINT

(unsigned integer) Encoded in 16 bits.

W

watchdog

A watchdog is a special timer used to ensure that programs do not overrun their allocated scan time. The watchdog timer is usually set to a higher value than the scan time and reset to 0 at the end of each scan cycle. If the watchdog timer reaches the preset value, for example, because the program is caught in an endless loop, a fault is declared and the program stopped.

WORD

A type encoded in a 16-bit format.



A

addressing
 direct, 70
 immediate, 70
 indirect, 70
 symbolic, 70

C

Configuration of Embedded HSC, 73
Controller Configuration
 Controller Selection, 64
 Services, 66

D

Download application, 57

E

Ethernet, 82
 Modbus TCP server, 92
 Modbus TCP slave device, 89
 Web server, 103
External Event, 32

H

Hardware Initialization Values, 51
high speed counters, 73

L

libraries, 21
library size, 25

M

Memory Mapping, 25
Memory Organization, 25, 25

O

Output Behavior, 51, 51, 51
Output Forcing, 51

P

Protocols
 IP, 84

R

Reboot, 55
Remanent variables, 60
Reset cold, 54
Reset origin, 55
Reset warm, 53
Run command, 53
RUN/STOP function, 68

S

Software Initialization Values, 51
State diagram, 39
Stop command, 53

T

Task
 Cyclic task, 31
 External Event Task, 32
 Freewheeling task, 32
 Types, 31
 Watchdogs, 33

W

Web server
 Ethernet, 103

