

Wind-Driven Rain Louver Dual Module

Application and Design

EHV-550 is a High Velocity Wind Driven Rain louver designed to protect intake and exhaust openings in building exterior walls. EHV-550 is tested in accordance with AMCA 500-L Air Performance, Water Penetration and Wind Driven Rain. EHV-550 is tested in accordance with AMCA 540 Test Method for Louvers Impacted by Wind Borne Debris (Basic Protection, Missile D and Enhanced Protection, Missile E). EHV-550 is tested in accordance with AMCA 550 Test Method for High Velocity Wind Driven Rain Resistant Louvers. EHV-550 is licensed to bear the AMCA seal allowing design professionals to select and apply with confidence.

Standard Construction

Frame Heavy gauge extruded 6005-T5 aluminum (jamb), heavy gauge extruded 6005-T5 aluminum (head & sill), 5.5 in. x 0.081 in. nominal wall thickness

Blades (Front) . . . J style, heavy gauge extruded 6005-T5 aluminum, 0.081 in. nominal wall thickness, positioned on approximately 1.9 in. blade spacing

Blades (Rear) . . . Vertical rain resistant style, heavy gauge extruded 6005-T5 aluminum, 0.050 in. nominal wall thickness, positioned on approximately 0.88 in. blade spacing

Construction . . . Mechanically fastened

Birdscreen 3/4 in. x 0.051 in. flattened expanded aluminum in removable frame, inside mount (rear)

Finish Mill

Minimum Size . . . 8 in. W x 12 in. H

Maximum Single

Section Size . . . 60 in. W x 96 in. H

Options (at additional cost)

- A variety of bird and insect screens
- Blank-off panel
- Clip angles
- Extended sill
- Filter rack
- Flanged frame
- Glazing Adapter
- Security bars
- A variety of architectural finishes including:
 - Clear anodize
 - Integral color anodize
 - Baked enamel
 - Kynar

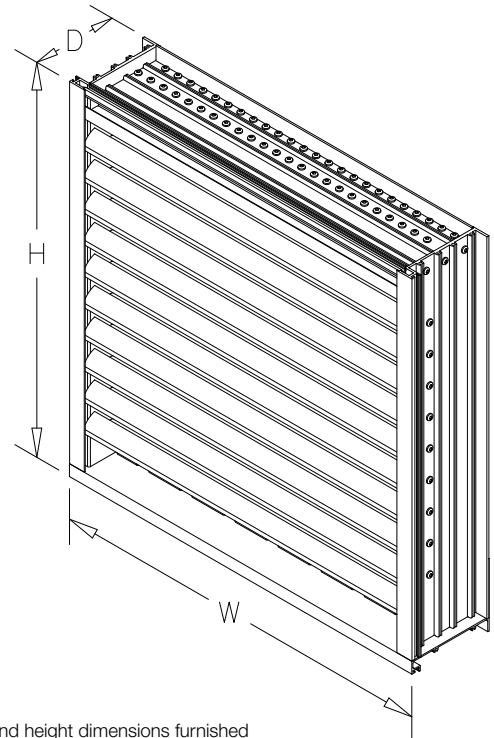
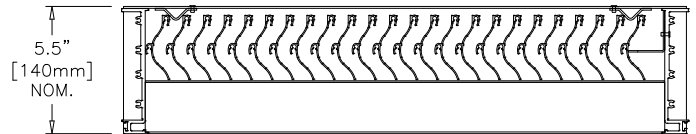
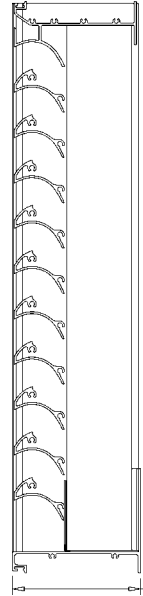

*Width and height dimensions furnished approximately 0.50 inch under size.

This label does not signify AMCA airflow performance certification.

PERFORMANCE DATA

EHV-550

Wind-Driven Rain Louver
Extruded Aluminum
AMCA 540 and 550 Listed

Wind-Driven Rain Performance

		75mm/h (3 in/hr) Rainfall & 13 m/s (29 mph) Wind Velocity				200mm/h (8 in/hr) Rainfall & 22 m/s (50 mph) Wind Velocity	
Ventilation Air Core Velocity m/s (fpm)	Free Area Velocity m/s (fpm)	Water Penetration Effectiveness %	Water Penetration Classification	Ventilation Air Core Velocity m/s (fpm)	Free Area Velocity m/s (fpm)	Water Penetration Effectiveness %	Water Penetration Classification
0.0 (0)	0.0 (0)		A	0.0 (0)	0.0 (0)		A
0.5 (98)	0.9 (177)		A	0.5 (98)	0.9 (177)		A
1.0 (197)	1.8 (356)		A	1.0 (197)	1.8 (356)		A
1.5 (295)	2.7 (533)		A	1.5 (295)	2.7 (533)		A
2.0 (394)	3.6 (712)		A	2.0 (394)	3.6 (712)		A
2.5 (492)	4.5 (889)		A	2.5 (492)	4.5 (889)		A
3.0 (591)	5.4 (1068)		A	3.0 (591)	5.4 (1068)		A
3.5 (689)	6.3 (1245)		A	3.5 (689)	6.3 (1245)		A
4.0 (787)	7.2 (1422)		A	4.0 (787)	7.2 (1413)	99.7	A
4.5 (886)	8.1 (1600)		A	4.5 (883)	8.1 (1595)	99.6	A
5.0 (980)	9.0 (1770)	100.0	A	5.0 (980)	9.0 (1770)	99.5	A

Discharge Loss Coefficient Class (Intake) = 3

Weather louvers shall be classified by their ability to reject simulated rain. The table shows different classifications based on the maximum simulated rain penetration per square meter (square feet) of louver. Water penetration rating at a given louver face velocity is determined by the water penetration while the louver is subjected to a selected simulated rainfall rate and wind velocity.

Airflow Resistance (Standard Air - .075 lb/ft³)

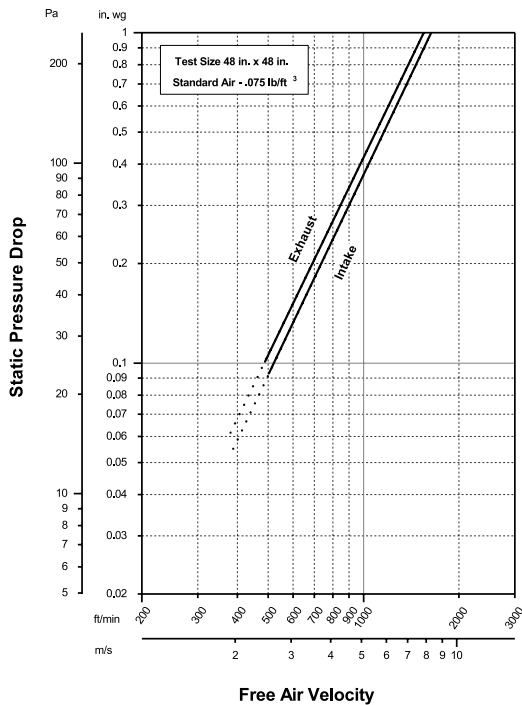

Model EHV-550 resistance to airflow (pressure drop) varies depending on louver application (air intake or air exhaust). Free area velocities (shown) are higher than average velocity through the overall louver size. See louver selection information. (Test Figure 5.5-6.5)

Water Penetration

Test Size 48 in. x 48 in. Test Duration of 15 min

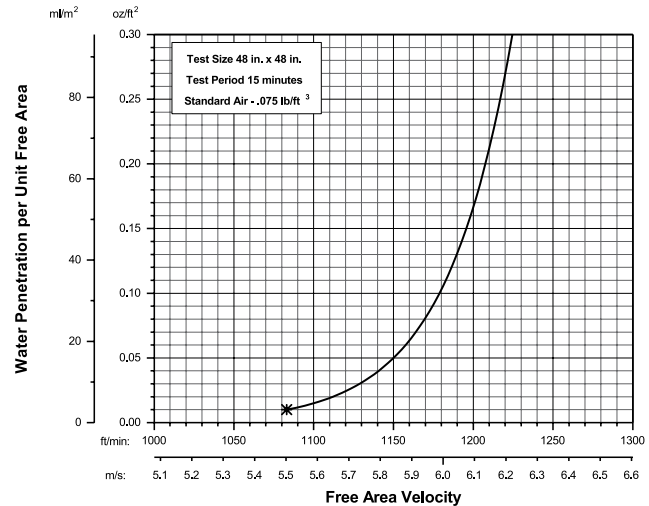

The AMCA Water Penetration Test provides a method for comparing various louver models and designs as to their efficiency in resisting the penetration of rainfall under specific laboratory test conditions. The beginning point of water penetration is defined as that velocity where the water penetration curve projects through 0.01 oz. of water (penetration) per sq. ft. of louver free area. ***The beginning point of water penetration for Model EHV-550 is 1083 fpm free area velocity.** These performance ratings do not guarantee a louver to be weather-proof or stormproof and should be used in combination with other factors including good engineering judgement in selecting louvers.

Greenheck Fan Corporation certifies that the EHV-550 louvers shown herein are licensed to bear the AMCA Seal. The ratings shown are based on tests and procedures performed in accordance with AMCA Publication 511 and comply with the requirements of the AMCA Certified Ratings Program. The AMCA Certified Ratings Seal applies to air performance, water penetration, and wind-driven rain ratings.

HIGH VELOCITY RAIN RESISTANT WITH BLADES FULLY OPEN AND IMPACT RESISTANT LOUVER Enhanced Protection Level E
See www.AMCA.org for all certified or listed products
This label does not signify AMCA airflow performance certification.

Greenheck Fan Corporation certifies that the EHV-550 louvers shown herein are approved to bear the AMCA Listing Label. The Ratings shown are based on tests and procedures performed in accordance with AMCA Publications and comply with the requirements of the AMCA Listing Label Program. The AMCA Listing Label applies to Wind Borne Debris Impact Resistant and High Velocity Wind-Driven Rain Resistant Louvers.

Discharge Loss Coefficient Classifications	
Class	Discharge Loss Coefficient
1	0.4 and Above
2	0.3 to 0.399
3	0.2 to 0.299
4	0.199 and Below

Wind-driven Rain Penetration Classes	
Class	Effectiveness
A	1 to 0.99
B	0.989 to 0.95
C	0.949 to 0.80
D	Below 0.80

PERFORMANCE DATA

EHV-550

Wind-Driven Rain Louver
Extruded Aluminum
AMCA 540 and 550 Listed

Free Area Chart (sq. ft.)

Louver Height Inches	Louver Width in Inches									
	8	12	18	24	30	36	42	48	54	60
12	0.14	0.23	0.38	0.52	0.66	0.81	0.95	1.09	1.24	1.38
18	0.27	0.47	0.75	1.04	1.33	1.61	1.90	2.19	2.47	2.76
24	0.42	0.72	1.16	1.60	2.04	2.48	2.92	3.36	3.80	4.24
30	0.57	0.97	1.56	2.16	2.75	3.35	3.94	4.54	5.13	5.73
36	0.72	1.22	1.97	2.72	3.47	4.22	4.97	5.72	6.47	7.22
42	0.87	1.47	2.38	3.28	4.19	5.10	6.00	6.91	7.81	8.72
48	1.01	1.71	2.76	3.81	4.86	5.92	6.97	8.02	9.07	10.12
54	1.15	1.94	3.14	4.33	5.53	6.72	7.92	9.11	10.31	11.50
60	1.28	2.18	3.52	4.86	6.20	7.54	8.88	10.22	11.56	12.90
66	1.43	2.43	3.93	5.42	6.92	8.41	9.91	11.40	12.90	14.39
72	1.58	2.68	4.33	5.98	7.63	9.29	10.94	12.59	14.24	15.89
78	1.73	2.93	4.74	6.55	8.35	10.16	11.97	13.77	15.58	17.38
84	1.88	3.19	5.15	7.11	9.07	11.03	12.99	14.95	16.91	18.87
90	2.02	3.42	5.52	7.63	9.73	11.83	13.94	16.04	18.14	20.25
96	2.15	3.65	5.90	8.14	10.39	12.64	14.89	17.13	19.38	21.63

Core Area Chart (sq. ft.)

Louver Height Inches	Louver Width in Inches									
	8	12	18	24	30	36	42	48	54	60
12	0.37	0.62	1.01	1.39	1.78	2.16	2.55	2.93	3.32	3.70
18	0.61	1.03	1.67	2.30	2.93	3.57	4.20	4.84	5.47	6.11
24	0.85	1.44	2.32	3.21	4.09	4.97	5.86	6.74	7.63	8.51
30	1.09	1.84	2.98	4.11	5.25	6.38	7.52	8.65	9.78	10.92
36	1.33	2.25	3.63	5.02	6.40	7.79	9.17	10.56	11.94	13.32
42	1.57	2.66	4.29	5.92	7.56	9.19	10.83	12.46	14.10	15.73
48	1.81	3.06	4.95	6.83	8.72	10.60	12.48	14.37	16.25	18.14
54	2.05	3.47	5.60	7.74	9.87	12.01	14.14	16.27	18.41	20.54
60	2.29	3.87	6.26	8.64	11.03	13.41	15.80	18.18	20.57	22.95
66	2.52	4.28	6.92	9.55	12.18	14.82	17.45	20.09	22.72	25.36
72	2.76	4.69	7.57	10.46	13.34	16.22	19.11	21.99	24.88	27.76
78	3.00	5.09	8.23	11.36	14.50	17.63	20.77	23.90	27.03	30.17
84	3.24	5.50	8.88	12.27	15.65	19.04	22.42	25.81	29.19	32.57
90	3.48	5.91	9.54	13.17	16.81	20.44	24.08	27.71	31.35	34.98
96	3.72	6.31	10.20	14.08	17.97	21.85	25.73	29.62	33.50	37.39

INSTALLATION DETAILS

EHV-550

Wind-Driven Rain Louver
 Extruded Aluminum
 AMCA 540 and 550 Listed

Maximum Size and Installation Information

Maximum single section size for model EHV-550 is 60 in. W x 96 in. H. Larger openings require field assembly of multiple louver sections to make up the overall opening size. Individual louver sections are designed to withstand a 25 PSF wind load (please consult Greenheck if the louvers must withstand higher wind-loads). Structural reinforcing members may be required to adequately support and install multiple louver sections within a large opening. Structural reinforcing members along with any associated installation hardware is not provided by Greenheck unless indicated otherwise by Greenheck. Options and accessories including, but not limited to, screens, filter racks, louver doors, and blank off panels are not subject to structural analysis unless indicated otherwise by Greenheck. Additional information on louver installation may be found in AMCA Publication #501, Louver Application Manual.

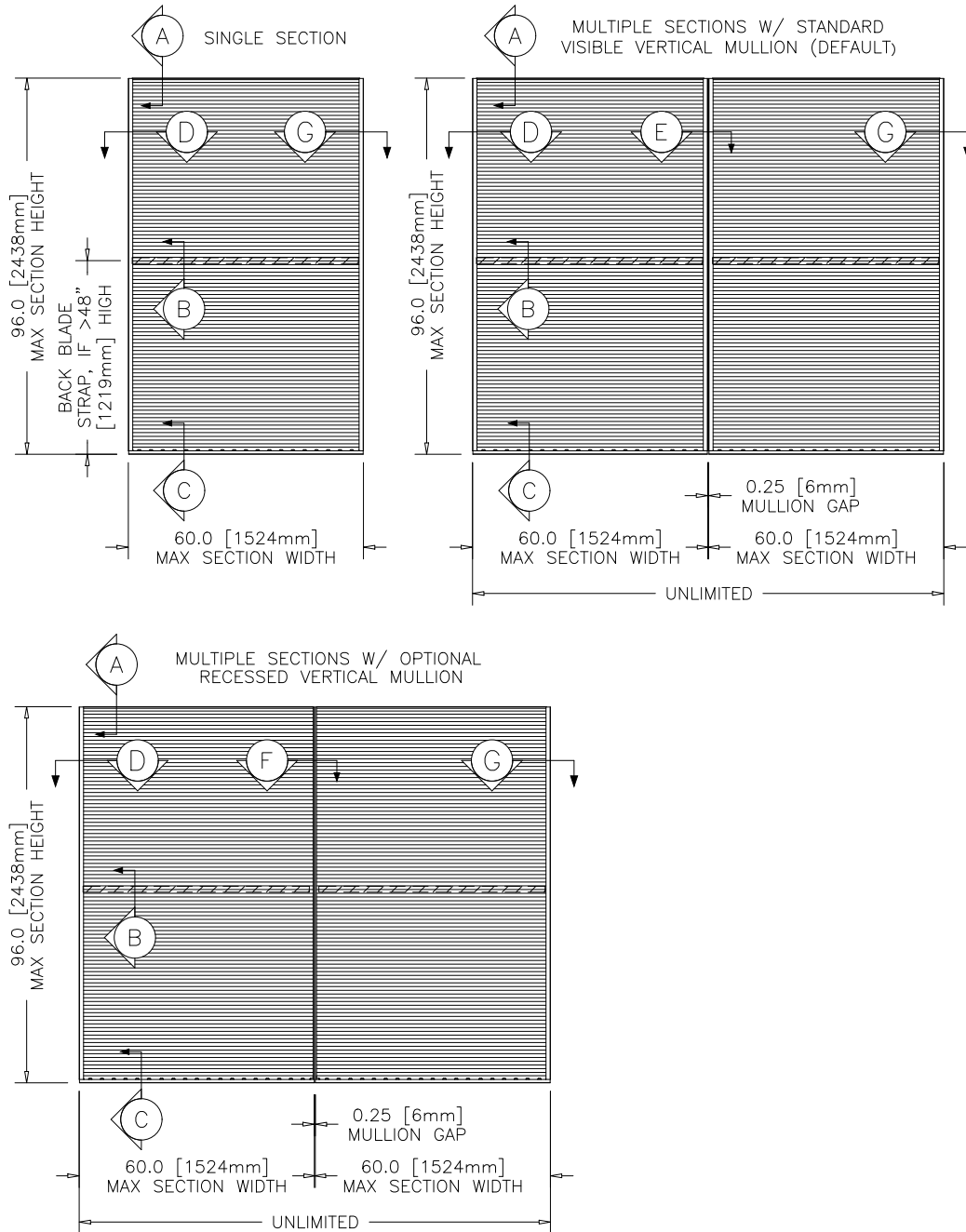

Minimum Single Section Size

8 in. W x 12 in. H

Maximum Single Section Size

60 in. W x 96 in. H

PRODUCT DETAILS

EHV-550

Wind-Driven Rain Louver
 Extruded Aluminum
 AMCA 540 and 550 Listed

NOTE: ALL SEALANT, BACKER ROD, NON-COMPRESSIBLE DEAD-LOAD SHIMS AND SUBSTRATE ARE NOT BY LOUVER MANUFACTURER (TYPICAL ALL DETAILS)

(A) HEAD DETAIL

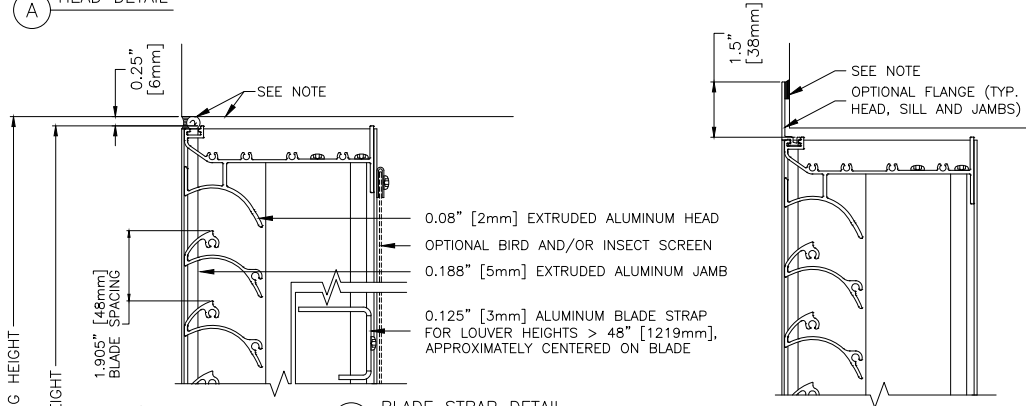

(B) BLADE STRAP DETAIL

IF HEIGHT IS > 48" [1219mm]

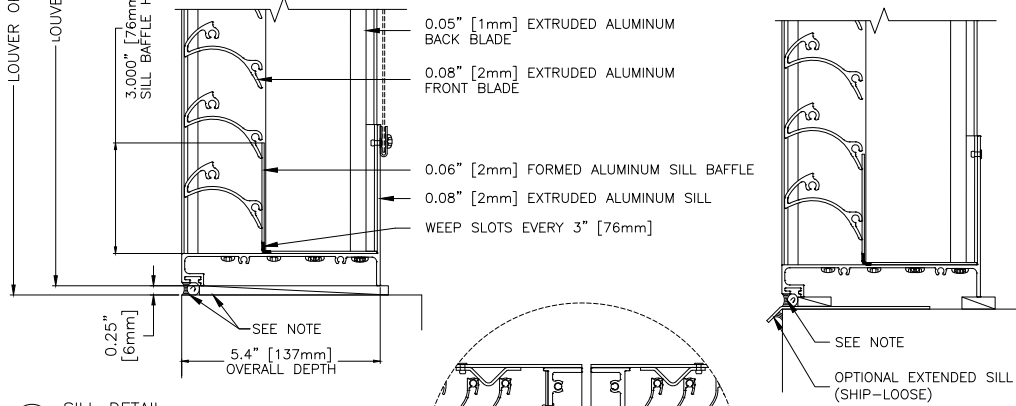

(C) SILL DETAIL

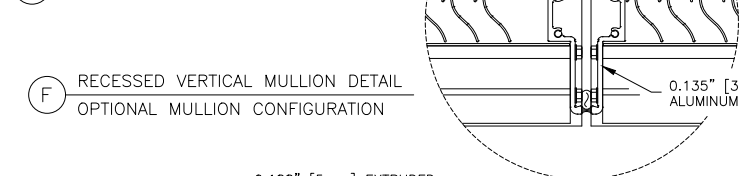

(F) RECESSED VERTICAL MULLION DETAIL
 OPTIONAL MULLION CONFIGURATION

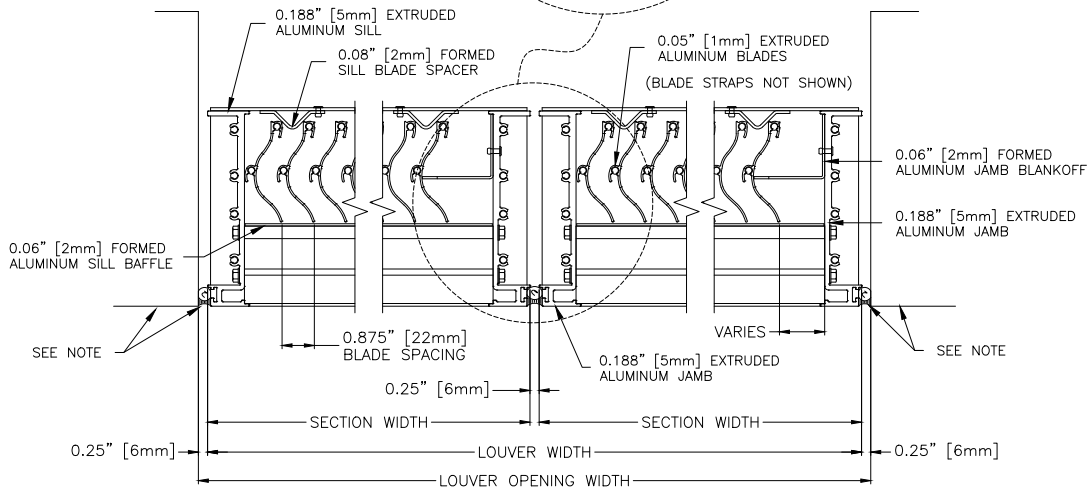
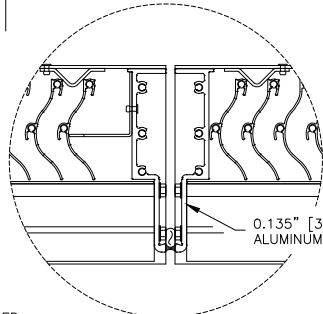

(D) JAMB DETAIL

(E) VISIBLE VERTICAL MULLION DETAIL
 STANDARD MULLION CONFIGURATION

(G) JAMB DETAIL

OPTION DRAWINGS

EHV-550

Wind-Driven Rain Louver
Extruded Aluminum
AMCA 540 and 550 Listed

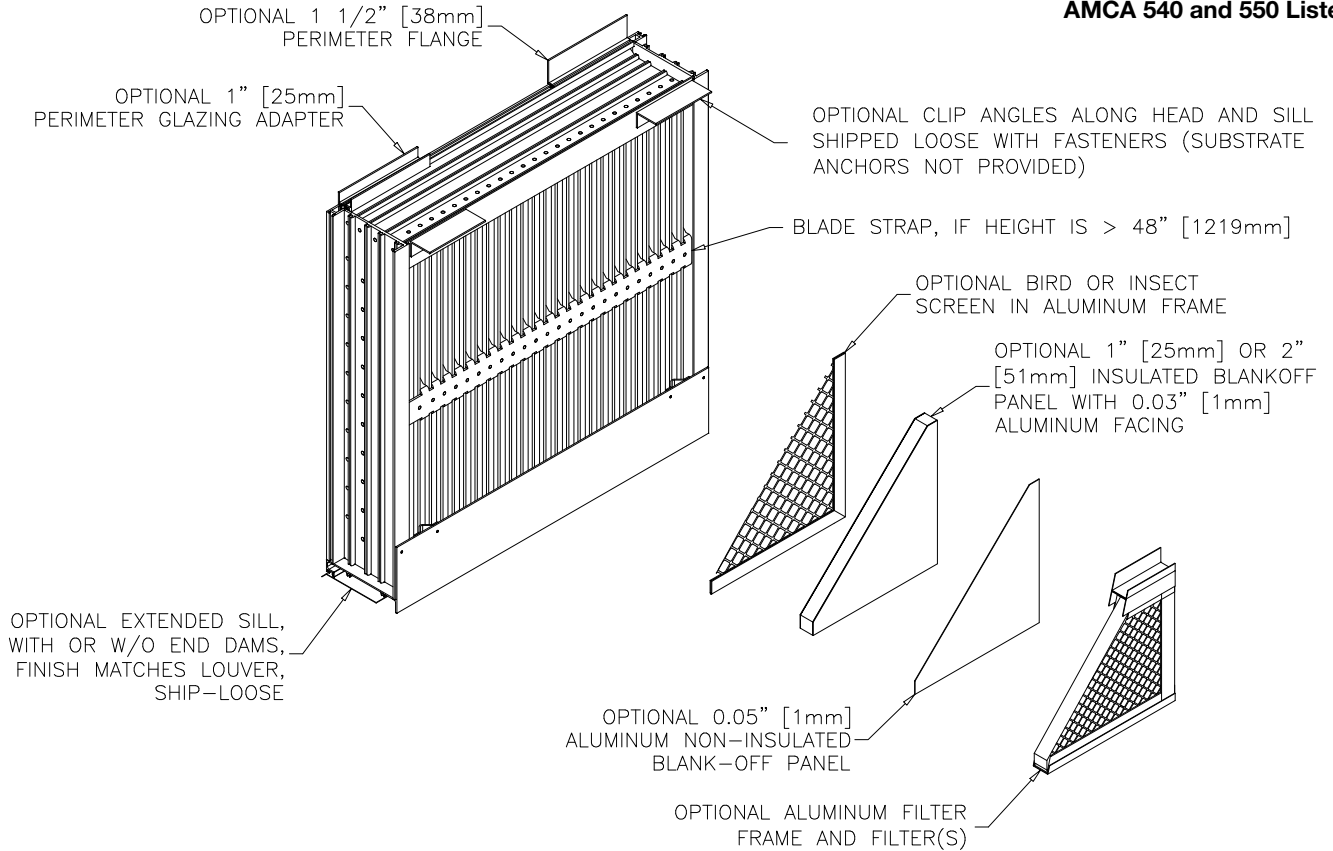

FINISHES

Finish Type	Description/Application	Color Selection	Standard Warranty (Aluminum)
AAMA 2605 100% Fluoropolymer (FEVE) 2-Coat 70% Kynar® (PVDF) 3-Coat 70% Kynar® (PVDF) 4-Coat 70% Kynar® (PVDF)	"Best." The premier finish for extruded aluminum. Tough, long-lasting coating has superior color retention and abrasive properties. Resists chalking, fading, chemical abrasion and weathering.	Standard Colors: Any of the 27 standard colors shown can be furnished in 70% or 50% Kynar®, 100% Fluoropolymer or Baked Enamel.	10 Years (20 Years Optional)
AAMA 2604 50% Kynar® / Acroflur®	"Better." Tough, long-lasting coating has excellent color retention and abrasive properties. Resists chalking, fading, chemical abrasion and weathering.	Mica Colors: Greenheck offers 6 standard Mica colors for 70% Kynar® or 100% Fluoropolymer.	5 Years
AAMA 2603 Baked Enamel	"Good." Provides good adhesion and resistance to weathering, corrosion and chemical stain.	Custom Colors: Custom color matching is available. Consult your Greenheck representative for cost and/or lead-time implications if a custom color is required.	1 Year
AA-M10C22A42 Integral Color Anodize	"Two-step" anodizing is produced by following the normal anodizing step with a second, colorfast process.	Light, Medium, Dark or Extra Dark Bronze; Champagne; Black	5 years
AA-M10C22A41 Clear Anodize 215 R-1	Clear, colorless and hard oxide aluminum coating that resists weathering and chemical attack.	Clear	5 years
AA-M10C22A31 Clear Anodize 204	Clear, colorless and hard oxide aluminum coating that resists weathering and chemical attack.	Clear	1 Year
Prime Coat	Louvers or architectural products shall be cleaned, pre-treated and receive a prime coat finish suitable for field painting. Greenheck does not recommend prime coat or field painting of materials.		n/a
Mill	Materials may be supplied in natural aluminum or galvanized steel finish when normal weathering is acceptable and there is no concern for color or color change.		n/a

Finishes meet or exceed AAMA 2605, AAMA 2604, and AAMA 2603 requirements. Please consult www.greenheck.com for complete information on standard and extended paint warranties. Paint finish warranties are not applicable to steel products.

