

ANSI/ISEA

Z87.1-2010

American National Standard
for Occupational and Educational
Personal Eye and Face
Protection Devices

ANSI/ISEA Z87.1-2010
Revision of
ANSI Z87.1-2003

**American National Standard
Occupational and Educational
Personal Eye and Face
Protection Devices**

Secretariat
International Safety Equipment Association

Approved April 13, 2010
American National Standards Institute, Inc.

American National Standard

An American National Standard implies a consensus of those substantially concerned with its scope and provisions. An American National Standard is intended as a guide to aid the manufacturer, the consumer, and the general public. The existence of an American National Standard does not in any respect preclude anyone, whether they have approved the standard or not, from manufacturing, marketing, purchasing, or using products, processes, or procedures not conforming to the standard. American National Standards are subject to periodic review and users are cautioned to obtain the latest editions.

The American National Standards Institute does not develop standards and will in no circumstances give an interpretation of any American National Standard. Moreover, no persons shall have the right or authority to issue an interpretation of an American National Standard in the name of the American National Standards Institute.

CAUTION NOTICE: This American National Standard may be revised or withdrawn at any time. The procedures of the American National Standards Institute require that action be taken to reaffirm, revise, or withdraw this standard no later than five years from the date of publication. Purchasers of American National Standards may receive current information on all standards by calling or writing the American National Standards Institute.

Published by

**International Safety Equipment Association
1901 North Moore Street, Suite 808, Arlington, Virginia 22209 USA**

Copyright 2010 by ISEA

All rights reserved.

No part of this publication (with the exception of Annex I, Selection Chart) may be reproduced in any form, in an electronic retrieval system or otherwise, without the prior written permission of the publisher.

Printed in the United States of America

Foreword (This Foreword is not a part of ANSI/ISEA Z87.1-2010)

The first version of a document that could be termed a “standard” dates back to 1922 with the first edition of the Z2 standard for head and eye protection. This standard originated from the cooperative work by the War and Navy Departments and the National Bureau of Standards.

Throughout the 1930’s and 1940’s the Z2 standard for eye and face protection was published as part of the initial 1938 National Bureau of Standards Handbook H24 that also included standards for respiratory and head protection. The 1946 revision was the first to recognize advances in materials technology and included criteria for materials other than glass. In 1959, Z2 was approved as the American Standard Safety Code for Head, Eye and Respiratory Protection.

In 1961 the Standards Safety Board split the Z2 project into three separate standards. Z87 for Eye and Face Protection, Z88 for Respiratory Protection and Z89 for head protection. On September 18, 1968 the eye and face protection standard was published with the Z87 designation, Z87.1-1968. Since then Z87.1 has been revised in 1979, 1989, and 2003.

This edition of Z87.1 represents a dramatic change in the way the standard is organized and how users of eye and face protectors will utilize the standard for selecting products for specific hazards. The 2003 edition of the Z87.1 standard and its predecessors were organized by the type of protector. Each type of protector, spectacles, goggles, faceshields and welding helmets had a chapter in the standard. The chapter described the protector, the required testing and optical properties and established product marking requirements. This led to significant repetition within the standard as some products have the same testing, optical and marking requirements.

In the process of revising Z87.1-2003, the Z87 Accredited Standards Committee (ASC) evaluated user needs, product variety and protection in an effort to write a document that is more useful for eye and face protection wearers. This 2010 edition is the product of work on behalf of the Z87 committee to develop a standard that focuses on the hazard and is organized by the nature of the hazard such as droplet and splash, impact, optical radiation, dust, fine dust and mist.

A benefit of this hazard approach to the standard is that it will encourage users and employers to evaluate the specific hazards that they are exposed to in their environment. Selection of appropriate eye and face protection will be based on this hazard evaluation. Because the standard is radically different, the product markings have changed. Users will need to be educated on matching the hazard that they need protection from with the marking on the product. The Z87 ASC also made efforts to parallel other eye and face protection standards used in the world. Many of the tables in this standard reflect this effort to harmonize with global standards.

Suggestions for improvement of this standard are welcome. They should be sent to the International Safety Equipment Association, 1901 N. Moore Street, Suite 808, Arlington, VA 22209, isea@safetyequipment.org.

This standard was processed and approved for submittal to ANSI by the Accredited Standards Committee on Safety Standards for Eye Protection, Z87. Committee approval of the standard does not necessarily imply that all committee members voted for its approval. At the time it approved this standard, the Z87 Committee had the following members:

Daniel Torgersen, Chairman
Jack B. Hirschmann, Jr., Vice-Chairman

Organization Represented**Name of Representative**

American Optometric Association	Gregory Good, O.D., Ph.D. Neil Hodur, O.D.
American Society of Safety Engineers	Jack B. Hirschmann, Jr.
American Welding Society	Philip M. Johnson
International Safety Equipment Association	John E. Salce Janice Comer Bradley, CSP
Jones and Company	Bruce Hey John Halliburton
3M Company	Nicole Vars McCullough, Ph.D. Robert A. Weber, CIH
National Association of Optometrists and Opticians	Lee Handel Franklin D. Rozak
National Institute for Occupational Safety and Health (NIOSH)	Larry L. Jackson, Ph.D. James R. Harris, Ph.D., P.E.
Optical Laboratories Association	Daniel Torgersen
Opticians Association of America	John M. Young Daryl Neely Brett Cohen Wayne Hill Mark Ferin
Power Tools Institute	Dan Hodge, OHST Christine Bradley, MS
PGRD	Anthony Jarecke, Major
Prevent Blindness America	James Elledge, Major David J. Hilber, Lt. Colonel
U.S. Department of the Air Force	Margaret Read, Lt. Commander
U.S. Dept. of the Army	J.P. Sankpill Jeffrey Endres Kenneth Wood Patrick Mumford
U.S. Dept. of the Navy	Nancy L.S. Yamasaki, Ph.D.
U.S. Safety	John McCarthy
The Vision Council	Daniel Torgersen Richard Harley Mili Mavely James K. Byrnes Janice C. Bradley, CSP
Younger Optics	Dale B. Pfriem, Individual Expert Michael W. Schaus David Sliney William E. Newcomb
ANSI Z80 Committee Ophthalmic Lenses	
ANSI Z88 Committee Respiratory Protection	
Z89 Committee Head Protection	
ICS Laboratories, Inc.	
Individual Expert	
Individual Expert	
Individual Expert	

Table of Contents

TOPIC	PAGE
Foreword	
1 Preface	1
2 Scope, Purpose, Application, and Interpretations	1
2.1 Scope.....	1
2.2 Purpose	1
2.3 Application.....	1
2.4 Interpretations	2
3 Definitions	2
4 Normative References.....	6
5 General Requirements.....	6
5.1 Optical Requirements	6
5.2 Physical Requirements.....	7
5.3 Minimum Lens Thickness	8
5.4 Marking Requirements	8
5.5 Other Requirements	8
5.6 Replaceable Lenses.....	11
5.7 Aftermarket Components.....	11
6 Impact Protector Requirements.....	11
6.1 General.....	11
6.2 Impact Requirements	12
6.3 Additional Impact Requirements for Specific Protector Types	13
7 Optical Radiation Protector Requirements	13
7.1 Transmittance of Lenses	13
7.2 Transmittance of Housings	15
8 Droplet and Splash, Dust, and Fine Dust Protector Requirements	17
8.1 Droplet and Splash Hazard	17
8.2 Dust Hazard	17
8.3 Fine Dust Hazard	17
9 Test Methods.....	17
9.1 Optical Quality Test.....	17
9.2 Transmittance Test.....	17
9.3 Haze Test	17
9.4 Refractive Power, Astigmatism and Resolving Power Tests.....	17
9.5 Prismatic Power Test	18
9.6 Drop Ball Test.....	19
9.7 Ignition Test.....	19
9.8 Corrosion Resistance Test	19

9.9	Light Tightness Test	20
9.10	Lateral Protection Test.....	20
9.11	High Mass Impact Test.....	20
9.12	High Velocity Impact Test.....	21
9.13	Penetration Test	22
9.14	Prescription Lenses Test	23
9.15	Switching Index Test	23
9.16	Droplet and Splash Test.....	24
9.17	Dust Test.....	25
9.18	Fine Dust Particle Test.....	26
10	Instructions, Use and Maintenance	26
10.1	General	26
10.2	Instructions.....	27
10.3	Inspections	27
10.4	Maintenance.....	27
10.5	Care.....	27
10.6	Training.....	27

Annexes

Annex A	Samples for Testing (normative).....	28
Annex B	Reference Headforms (normative)	29
Annex C	Spectral Factor Tables (normative)	31
Annex D	Lateral (Side) Coverage Illustration (Medium Headform) (informative)	35
Annex E	Test Apparatus (informative)	36
Annex F	Calibration of Test Telescope (informative)	40
Annex G	Sources for Test Apparatus (informative)	41
Annex H	Resource Publications (informative)	42
Annex I	Selection Chart (informative).....	43
Annex J	Hazard Assessment and Protector Selection (informative)	44

Tables

Table 1	Tolerance on Refractive Power, Astigmatism and Resolving Power.....	6
Table 2	Tolerance on Prism and Prism Imbalance	7
Table 3	Minimum Lens Thickness	8
Table 4a	Marking Requirements	9
Table 4b	Sequence of Markings	10
Table 5	High Velocity Impact Testing	12
Table 6	Transmittance Requirements for Welding Filters	14
Table 7	Transmittance Requirements for Ultraviolet Filters.....	15
Table 8	Transmittance Requirements for Infrared Filters	15
Table 9	Transmittance Requirements for Visible Light Filters	16
Table 10	Transmittance Requirements for Special Purpose Lenses.....	16
Table 11	Switching Index Requirements for Automatic Darkening Welding Filter Lenses	16

Explanation of Standard

The information and materials contained in this publication have been developed from sources believed to be reliable. However, the International Safety Equipment Association (ISEA) as secretariat of the ANSI accredited Z87 Committee or individual committee members accept no legal responsibility for the correctness or completeness of this material or its application to specific factual situations. By publication of this standard, ISEA or the Z87 Committee does not ensure that adherence to these recommendations will protect the safety or health of any persons, or preserve property.

American National Standard for Occupational and Educational Personal Eye and Face Protection Devices

1. Preface

This standard for personal eye and face protectors is, as far as possible, designed to be performance oriented.

Every effort should be made to eliminate eye and face hazards in occupational and educational settings. Protectors do not provide unlimited protection. In the occupational and educational environment, protectors are not substitutes for machine guards and other engineering controls. Protectors alone should not be relied on to provide complete protection against hazards, but should be used in conjunction with machine guards, engineering controls, and sound safety practices.

In 1992, the U.S. Occupational Safety and Health Administration began regulating occupational exposure to bloodborne pathogens and, as a result, now requires employers to provide personal protective equipment (PPE) including eye and face protection for employees exposed to these hazards. At the time of the publication of this standard, no standards existed for eye and face protection intended to provide protection from bloodborne pathogens. Nevertheless many employers have elected to provide their employees with PPE conforming to the requirements of ANSI/ISEA Z87.1. These products may or may not provide adequate protection against bloodborne pathogens. Extreme caution must be exercised in the selection and use of personal protective equipment in applications for which no performance requirements or standardized testing exist.

2. Scope, Purpose, Application, and Interpretations

2.1 Scope

This standard sets forth criteria related to the general requirements, testing, permanent marking, selection, care, and use of protectors to minimize the occurrence and severity or prevention of injuries from such hazards as impact, non-

ionizing radiation and chemical exposures in occupational and educational environments including, but not limited to, machinery operations, material welding and cutting, chemical handling, and assembly operations. Certain hazardous exposures are not covered in this standard. These include, but are not limited to: bloodborne pathogens, X-rays, high-energy particulate radiation, microwaves, radio-frequency radiation, lasers, masers, and sports and recreation.

2.2 Purpose

This standard provides minimum requirements for protectors including selection, use, and maintenance of these protectors as devices to minimize or prevent eye and face injuries.

2.3 Application

2.3.1 The requirements of this standard apply to protectors when first placed in service.

2.3.2 Protectors bearing the permanent marking Z87 shall meet all applicable requirements of this standard in its entirety. All components of eye and face protectors shall comply with the requirements of this standard. Accessories installed by the manufacturer shall not cause the protector to fail the requirements of this standard. Manufacturers of components and complete protectors shall ensure that all required tests have been performed to demonstrate conformance.

2.3.3 Compliance with this standard cannot always be assured when replacement components are used. End users should exercise extreme care in the selection and installation of replacement components to ensure compliance with this standard.

2.3.4 Non-compliant components shall not be used with ANSI/ISEA Z87-compliant components.

2.3.5 The protector manufacturer shall provide test results to the purchaser upon request.

2.4 Interpretations

Requests for interpretations of this standard shall be in writing and addressed to the secretariat (isea@safetysafetyequipment.org) of this accredited standard committee.

3. Definitions

For purposes of this standard, the following definitions shall apply:

astigmatism. A condition in a lens of a protector in which there is a difference in refractive power in one meridian from that in another meridian.

automatic darkening welding filter lens. A filter lens that automatically switches from a light state to a dark state in response to a change of light intensity.

bluelight transmittance T_B . Transmittance of optical radiation weighted by its ability to cause photochemical damage to the retina is defined as:

$$T_B = \frac{\int_{400}^{700} T(\lambda)B(\lambda)d\lambda}{\int_{400}^{700} B(\lambda)d\lambda}$$

where $B(\lambda)$ is the BlueLight Hazard Function defined in Table C4 of Annex C.

chin protector. That portion of a device that offers protection to a wearer's lower face, chin and neck.

complete device. A product with all its components in their configuration of intended use, subjected to testing for determination of compliance with the standard.

component. A functional part of a complete device addressed by the performance requirements of this standard.

crown. That portion of a device that offers protection to a wearer's forehead.

dark state. The lowest operating luminous transmittance of an automatic darkening filter

lens.

diopter (D). A unit of measurement (plus or minus) used to express the power of a lens. It is expressed as the reciprocal of the focusing distance given in meters. The diopter is also used to express the curvature of surfacing tools and the refracting power of curved surfaces.

effective far-ultraviolet average transmittance

\bar{T} (EFUV). Transmittance of optical radiation with wavelengths from 200 to 315 nanometers weighted by its ability to damage the cornea. When $T(\lambda)$ is defined as the spectral transmittance of the filter at wavelength, \bar{T} (EFUV) is defined as:

$$\bar{T}(\text{EFUV}) = \frac{\int_{200}^{315} T(\lambda)W(\lambda)d\lambda}{\int_{200}^{315} W(\lambda)d\lambda}$$

where $W(\lambda)$ is the Spectral Weighting Factor given in Table C1 of Annex C.

eyewire. The component of a frame front encircling one lens.

faceshield. A protector commonly intended to, when used in conjunction with spectacles and/or goggles, shield the wearer's face, or portions thereof, in addition to the eyes, from certain hazards, depending on faceshield type.

filter lens. A lens that attenuates specific wavelengths of ultraviolet, visible, and/or infrared radiation.

fracture. A lens will be considered to have fractured if it cracks through its entire thickness into two or more separate pieces, or if any material visible to the naked eye becomes fully-detached from the inner surface.

frame. A structure, which holds the lens or lenses on the wearer.

front. That part of a spectacle or goggle frame that is intended to contain the lens or lenses.

full facepiece respirator. A tight fitting respirator that covers the nose, mouth and eyes from approximately the hairline to below the chin.

goggle. A protector intended to fit the face surrounding the eyes in order to shield the eyes from certain hazards, depending on goggle type.

handshield. A hand-held welding helmet. See "welding helmet."

haze. The percent of incident light that is not transmitted in a straight line through the lens but forward scattered, greater than 2.5° diverging.

headform. Apparatus constructed in accordance with specifications outlined in EN168:2001, Section 17 utilized in the testing of protective devices as specified in Section 9, Test Methods. (Refer to Annex B)

headgear/adaptor. That part of a helmet, hood or faceshield that supports the device on the wearer's head.

infrared average transmittance. Transmittance of optical radiation with wavelengths from 780 to 2000 nanometers weighted by its ability to damage the cornea. When $T(\lambda)$ is defined as the spectral transmittance of the filter at wavelength, $\bar{T}(IR)$ is defined as:

$$\bar{T}(IR) = \frac{\int_{780}^{2000} T(\lambda)S(\lambda)d\lambda}{\int_{780}^{2000} S(\lambda)d\lambda}$$

where, in the infrared, the relative spectral emittance $S(\lambda)$ of Illuminant A is that of a full ("Black-body") radiator at temperature 2856° K and is given in Table C3 of Annex C.

infrared radiation (IR). As related to this standard, electromagnetic energy with wavelengths from 780 to 2000 nanometers.

lens. The transparent part of a protector through which the wearer sees, also referred to as a plate or window for some devices.

lens housing or carrier. That part of a goggle, welding helmet or handshield that mechanically houses a lens.

lift-front. A type of supplementary lens and holder that covers the viewing area of a protector immediately in front of the wearer's eyes and that can be positioned outside the line of sight.

light. Optical radiation weighted by its ability to cause visual sensations.

light state. The highest luminous transmittance of an automatic darkening welding filter lens, when not in a dark state.

loose fitting respirator. A respiratory inlet covering that is designed to form a partial seal with the face, or that completely covers the head and neck, and may cover portions of the shoulder.

luminous transmittance (T_L). The fraction of light (380-780 nm) passing through a medium, is defined in this standard with respect to the light source CIE Illuminant A and the CIE 1931 Standard Colorimetric Observer, and is expressed as:

$$T_L = \frac{\int_{380}^{780} T(\lambda)\bar{y}(\lambda)S(\lambda)d\lambda}{\int_{380}^{780} \bar{y}(\lambda)S(\lambda)d\lambda}$$

where $\bar{y}(\lambda)$ is the relative luminous efficiency function and $S(\lambda)$ is the relative spectral emittance of Illuminant A as defined by the CIE. These functions are given in Table C2 of Annex C.

lux (lx). A unit of measurement of illuminance equal to one lumen per square meter of the illuminated surface.

manufacturer. The business entity that marks or directs the permanent marking of the components or complete devices as compliant with this standard, and sells them as compliant.

millisecond (ms). One thousandth of a second; 10^{-3} second.

nanometer (nm). A unit of measurement of wavelength equal to one billionth of a meter; 10^{-9} meter.

near-ultraviolet average transmittance. Transmittance of optical radiation with wavelengths from 315 to 380 nanometers. When $T(\lambda)$ is defined as the spectral transmittance of the filter at wavelength, \bar{T} (NUV) is defined as:

$$\bar{T} \text{ (NUV)} = \frac{\int_{315}^{380} T(\lambda) d\lambda}{\int_{315}^{380} d\lambda}$$

non-removable lens. A lens and holder that are homogeneous and continuous or a lens that cannot be removed from the frame/front without damage to the device.

optical radiation. As related to this standard, that portion of the electromagnetic spectrum ranging in wavelength from 200 nm to 2000 nm.

permanent mark/markings. A mark that cannot be removed without evidence of removal.

photochromic lens. A lens which darkens when exposed to, and fades when removed from, ultraviolet radiation and/or sunlight.

plano lens. A lens that does not incorporate a corrective prescription; this lens is not necessarily flat.

power. See "refractive power", "resolving power", and "prismatic power".

prescription lens (Rx). A lens manufactured to the wearer's individual corrective prescription.

prescription lens carrier. A lens frame with prescription lenses that mounts inside a protector to provide vision correction.

prismatic power, "prism". A measure of the angular deviation expressed in prism diopters (Δ) of a light ray after passing along the viewing path through a lens. One prism diopter equals a deviation of 1 cm per meter of path length.

protector. A complete device meeting, at a minimum, the requirements of Section 5 this standard.

refractive power, "power". A measure of the ability of a lens to focus light rays, expressed in diopters (D).

removable lenses. Prescription or plano lenses fabricated to fit a single spectacle frame.

replaceable lenses. Interchangeable lens/fronts designed for spectacle, goggle or welding helmet devices that are directly mounted to the frame or shell of the device.

representative test lenses. Lenses produced of the same materials, coatings, thicknesses (minimum values), lens surfacing and framing processes as used for prescription lenses by the manufacturer.

resolving power, "definition". The measure of the ability of a lens to form separate distinct images of two objects close together.

retained. In this standard, the use of the word "retained" means that the lens is not separated or visibly displaced from the frame by more than 25% of its intended mounting structure or support.

safety plate. That portion of the device that provides impact protection in the lens region of the protector.

scale. A designator in which the first character indicates the type of radiation protector and the second character is a number which increases with more attenuation. The radiation protector characters are U for an ultraviolet radiation attenuator, R for infrared radiation attenuator and L for visible radiation attenuator.

screen. A mesh or gauze material made of any suitable substance (e.g. metal wire, plastic filament or fiber).

shade, S. Related to luminous transmittance, T_L (expressed as a fraction, not as a percent) by the equation:

$$S = \frac{7}{3} \text{Log}_{10} \frac{1}{T_L} + 1$$

shall. In this standard, the use of the word "shall" indicates a mandatory requirement.

shell. That portion of welding helmet or hand-shield that covers the wearer's face.

should. In this standard, the use of the word "should" indicates a recommendation.

sideshield. A permanent or detachable part of a spectacle that provides side impact resistance, and that may be an original or aftermarket component.

special purpose protectors/lenses. Protectors and lenses which meet the requirements of Table 10, but may or may not meet the requirements of Table 6, 7, 8 or 9. They are designed for specific applications.

spectacle. A protector intended to shield the wearer's eyes from certain hazards, depending on the type.

switching index. The response time of an automatic darkening welding filter lens is defined as:

$$\text{Switching Index} = \frac{1}{T_1} \int_{t=0}^{t=T=3T_2} T(t) dt$$

where: $t = 0$ is the time at which the arc ignites, T_1 is the designated light state, T_2 is the designated dark state, $t[T=3T_2]$ is the time at which the luminous transmittance falls to three times the luminous transmittance in the dark state.

Note: During short term exposure to light, the discomfort of bright light is approximately proportional to the product of the illuminance at the eye and time. The time dependence of the darkening process can differ for different designs of filters where the luminous transmittance varies with time. It is therefore appropriate to define the response time of an automatic darkening filter lens as an integral of the luminous transmittance over time and not merely by the initial and final luminous transmittance.

temple. That part of a spectacle frame commonly attached to the front and generally extending behind the ear of the wearer.

tinted lens. A lens with color such as amber, smoke, or cobalt which does not meet the requirements of Table 6, 7, 8 or 9.

type tests. One or more tests performed on an item to approve a material, construction, model or design to determine if it is capable of meeting the requirements of a product standard.

ultraviolet radiation (UV). Electromagnetic energy with wavelengths from 200 to 380 nanometers.

variable tint lens. A lens which darkens or fades by some mechanism, excluding automatic darkening welding filters. These are typically photochromic lenses and may or may not meet the requirements of Table 6, 7, 8 or 9.

visible light filter. A filter lens, commonly known as a sunglass lens, intended for the attenuation of visible light and suitable for traffic signal recognition.

welding goggle. A goggle intended for limited welding applications.

welding faceshield. A faceshield intended for specific welding applications.

welding filter lens. A lens specified for use for welding or brazing.

welding helmet. A faceshield-type device intended to provide protection specifically to the eyes and face against optical radiation and weld spatter.

welding respirator. A respirator intended to provide optical radiation protection for welding operations.

window. The lens portion of a faceshield (see "lens").

4. Normative References

The following documents contain provisions, which, through reference in this text, constitute mandatory provisions of this standard. Other resource materials, which do not contain mandatory provisions, are listed in Annex H.

American Conference of Governmental Industrial Hygienists - *Threshold Limit Values for Chemical Substances and Physical Agents & Biological Exposure Indices for 2008*

ANSI Z80.1-2005, *American National Standard for Ophthalmics - Prescription Ophthalmic Lenses – Recommendations*

ANSI Z80.3-2008 *American National Standard for Ophthalmics - Nonprescription Sunglasses and Fashion Eyewear – Requirements*

ANSI Z80.5-2004, *American National Standard Requirements for Dress Ophthalmic Frames*

ASTM D1003-2000, *Standard Test Method for Haze and Luminous Transmittance of Transparent Plastics*

EN 168:2001, *European Standard – Personal eye protection – Non-optical test methods*

NBS Special Publication 374

5. General Requirements

All protectors shall satisfy all applicable requirements of Section 5.

5.1 Optical Requirements

5.1.1 Optical Quality

When tested in accordance with Section 9.1, protector lenses shall be free of striae, bubbles, waves and other visible defects which would impair their optical quality.

5.1.2 Luminous Transmission

When tested in accordance with Section 9.2, clear lenses shall have a luminous transmission of not less than 85%.

5.1.3 Haze

When tested in accordance with Section 9.3, clear plano lenses shall not exhibit more than 3% haze.

5.1.4 Refractive Power, Astigmatism, Resolving Power, Prism and Prism Imbalance for Plano Protectors

When tested in accordance with Section 9.4, the tolerance on refractive power, astigmatism and resolving power shall be as indicated in Table 1. Filter lenses of shade 9 or higher are exempt from this testing. When tested in accordance with Section 9.5, the tolerance on prism and prism imbalance shall be as indicated in Table 2.

Table 1. Tolerance on Refractive Power, Astigmatism and Resolving Power

Protector	Refractive Power	Astigmatism	Resolving Power
Spectacle	±0.06 D	≤ 0.06 D	Pattern 20
Goggle	±0.06 D	≤ 0.06 D	Pattern 20
Faceshield windows	No requirement	No requirement	Pattern 20
Welding helmet lenses	±0.06 D	≤ 0.06 D	Pattern 20

Table 2. Tolerance on Prism and Prism Imbalance

Protector	Prism	Vertical Imbalance	Base In Imbalance	Base Out Imbalance
Spectacle	$\leq 0.50 \Delta$	$\leq 0.25 \Delta$	$\leq 0.25 \Delta$	$\leq 0.50 \Delta$
Goggle	$\leq 0.25 \Delta$	$\leq 0.125 \Delta$	$\leq 0.125 \Delta$	$\leq 0.50 \Delta$
Faceshields	$\leq 0.37 \Delta$	$\leq 0.37 \Delta$	$\leq 0.125 \Delta$	$\leq 0.75 \Delta$
Welding helmet lenses	$\leq 0.50 \Delta$	$\leq 0.25 \Delta$	$\leq 0.25 \Delta$	$\leq 0.75 \Delta$

5.1.5 Refractive Power, Astigmatism, Prism and Prism Imbalance for Prescription Protectors

For prescription protectors, the tolerance on refractive power, astigmatism, prism and prism imbalance shall be those contained in ANSI Z80.1-2005, *American National Standard for Ophthalmics - Prescription Ophthalmic Lenses - Recommendations*.

NOTE: There is no resolving power requirement for prescription lenses.

5.2 Physical Requirements

Protectors shall be free from projections, sharp edges or other defects which are likely to cause discomfort or injury during use.

5.2.1 Drop Ball Impact Resistance

When tested in accordance with Section 9.6, protector lenses shall not fracture when impacted by a 25.4 mm (1 in.) steel ball when dropped from a height of 127 cm (50 in.). Glass welding filter lenses shall be tested and used in conjunction with a safety plate in order to comply with the impact performance criteria.

5.2.2 Protector Acceptance Criteria

When each type test is conducted as indicated above, a complete device shall fail if any of the following occurs:

- piece fully detached from the inner surface
- fracture
- penetration of the rear surface
- lens not retained

5.2.3 Ignition

When tested in accordance with Section 9.7, protectors shall not ignite or continue to glow once the rod is removed. Each externally exposed material (exclusive of textiles or elastic bands) shall be tested.

5.2.4 Corrosion Resistance of Metal Components

When tested in accordance with Section 9.8, metal components used in protectors shall be corrosion resistant to the degree that the function of the protector shall not be impaired by the corrosion. Lenses and electrical components are excluded from these requirements.

5.2.5 Minimum Coverage Area

The eyewire and lens shall cover in plane view an area of not less than 40 mm (1.57 in.) in width and 33 mm (1.30 in.) in height (elliptical) in front of each eye, centered on the geometrical center of the lens.

Frames designed for small head sizes shall cover in plane view an area of not less than 34 mm (1.34 in.) in width and 28 mm (1.10 in.) in height (elliptical), centered on the geometrical center of the lens.

Frames designed for small head sizes shall be tested on the 54 mm (2.13 in.) PD headform and are permitted to have an eye size, including eyewire thickness, as small as 34 x 28mm (1.34 x 1.10 in.). Frames that are tested using the small headform shall be marked on the frame with the letter "H."

5.3 Minimum Lens Thickness

The minimum lens thickness for specified protectors shall be those indicated in Table 3.

Table 3. Minimum Lens Thickness

Protector	Minimum Thickness ¹
Spectacle, plano ²	≥ 3.0 mm (0.12 in.)
Spectacle, plano, impact rated	No Minimum Thickness Requirement
Spectacle, prescription	≥ 3.0 mm (0.12 in.) ≥ 2.5 mm (0.10 in.) if power in the most plus meridian of the distance portion is ≥ +3.00 D
Spectacle, prescription, impact rated	≥ 2.0 mm (0.08 in.)
Goggles	≥ 3.0 mm (0.12 in.); glass ≥ 1.27 mm (0.05 in.), non-glass
Goggles, impact rated	No Minimum Thickness Requirement
Faceshield	≥ 1.0 mm (0.04 in.)
Faceshield, impact rated	No Minimum Thickness Requirement
Welding helmets	No Minimum Thickness Requirement

¹No minimum thickness requirement applies to the protector beyond a vertical plane passing through the 90° impact point.

²For plano spectacles, no minimum thickness is required for protectors if they meet the requirements of Section 9.11, High Mass Impact Test.

5.4 Marking Requirements

All protectors shall bear the permanent markings in specified locations as shown in Table 4a. Markings shall follow the sequence shown in Table 4b. Markings for lens type and use applications shall be required only when claims for protection against the hazard or indicated use are made by the manufacturer.

In addition, the components of frames that are intended for prescription protector use shall be

marked for size in accordance with the system described in ANSI Z80.5-2004. Fronts shall be marked with the A-dimension (eye size) and DBL (distance between lenses). Temples shall be marked with their overall length.

5.5 Other Requirements

5.5.1 Goggles

If the goggle is equipped with adjustable ventilation, the protector shall be tested in the maximum open position.

5.5.1.1 Direct Ventilation

The vented portion of the goggle shall be such that the openings exclude spherical objects 1.5 mm (0.06 in.) in diameter or greater.

5.5.1.2 Indirect Ventilation

The vented portion of the goggle shall be such that no direct straight-line passage from the exterior to the interior of the goggle exists.

5.5.2 Screen Windows and Screen Lenses

Exposed borders of screen windows and cutouts in the screen window (combination plastic and screen) shall be finished in such a manner as to eliminate any sharp, rough or unfinished edges. Screen windows and lenses are exempt from penetration, optical and minimum thickness requirements.

5.5.3 Welding Protectors

5.5.3.1 Transmittance of Non-Lens Areas

When tested in accordance with Section 9.2, the thinnest non-lens area of welding protectors with removable lenses that exposes itself forward shall transmit no more optical radiation than that permitted by Table 6 for shade number 14. Non-lens areas of welding protectors with non-removable lenses shall transmit no more optical radiation than that of the lens.

5.5.3.2 Light Tightness

When tested in accordance with Section 9.9, there shall be no penetration of direct visible light in all non-lens areas including the space between the lens and lens housing or carrier.

Table 4a. Marking Requirements

Type of Mark	Lenses & Replacement Lenses		Frame ¹	Marking for Complete Device (no replaceable parts) ²
	Spectacles	All Other		
All protectors shall bear the markings below.				
Manufacturer's Mark or Logo	Yes	Yes	Yes	Yes
Standard				
Plano		Z87	Z87	Z87
Rx		Z87	Z87-2	Z87-2
Coverage (small head sizes) ³	H		H	
The following shall be required only when claims of impact rating, a specific lens type and/or use are made by the manufacturer.				
Impact Mark				
Impact Rated Plano	+	Z87+	Z87+	Z87+
Impact Rated Rx	+	Z87+	Z87-2+	Z87-2+
Lens Type				
Clear				
Welding (see table 6)	W shade	W shade		W shade
UV Filter (see table 7) ⁴	U scale number	U scale number		U scale number
Visible Light Filter (see table 9) ⁴	L scale number	L scale number		L scale number
IR Filter (see table 8) ⁴	R scale number	R scale number		R scale number
Variable Tint	V	V		V
Special Purpose	S	S		S
Use				
Splash / Droplet			D3	D3
Dust			D4	D4
Fine Dust			D5	D5

1. Frame components subject to marking vary by type of protector.

- Spectacles: Front and at least one temple. Both detachable sideshields are marked Z87+, if impact rated
- Goggles: Frame and lens housing or carrier
- Faceshields: Headgear/adaptor, crown and chin protector
- Welding helmets and handshields: Headgear/adaptor, shell and lens housing or carrier
- Respirators: None
- Prescription frames: Size marking on front and temples in accordance with ANSI Z80.5-2004

2. A complete device (no replaceable components) shall have at least one set of markings. The markings may be on the lens or the frames or both the lens and the frame.

3. For spectacle protectors, coverage marking "H" shall be on the lens for rimless or semi-rimless lens retention systems.

4. "Filter" include: UV, Visible and IR Light Filters. In case of multiple filter type compliance, designations shall be listed in the order given in this table: U, L, R.

Table 4b. Sequence of Markings

Markings can follow a top to bottom sequence or a left to right sequence.

DISCLAIMER: The information below is provided to demonstrate examples of resulting product markings compliant with ANSI/ISEA Z87.1-2010. Such information is not meant to be all-inclusive and is provided for illustrative purposes only.

Device	Manufacturer's Mark or Logo	Standard Mark	Impact Mark	Lens Type	Use	Resulting Mark
Lenses						
Faceshield, impact rated (shade 5)	ABC	Z87	+	W5		ABCZ87+W5
Goggle or faceshield, not impact rated (UV)	ABC	Z87		U3		ABCZ87U3
General purpose spectacle, not impact rated (shade 2.0)	ABC			W2.0		ABCW2.0
Frame						
Goggle, impact rated, fine dust rated	ABC	Z87	+		D5	ABCZ87+D5
Goggle, not impact rated, dust rated	ABC	Z87			D4	ABCZ87D4
Goggle, not impact rated, splash rated	ABC	Z87			D3	ABCZ87D3
Prescription spectacle w/no side protection	ABC	Z87-2				ABCZ87-2
Prescription spectacle, impact rated	ABC	Z87-2	+			ABCZ87-2+
Complete Device						
Goggle, faceshield (UV & IR)	ABC	Z87		U6 & R2		ABCZ87U6R2
Goggle, faceshield, impact rated, splash rated (shade 5)	ABC	Z87	+	W5	D3	ABCZ87+W5D3
Full facepiece respirator, clear lens, impact rated, splash rated, dust rated, fine dust rated	ABC	Z87	+		D3 D4 D5	ABCZ87+D3D4D5

5.5.4 Frames for Replaceable or Removable Lenses

All frames which can house replaceable or removable lenses shall be supplied with detailed specifications on the required lens bevel design or mounting technique and nominal lens sizing required to conform to ANSI/ISEA Z87.1-2010.

5.5.5 Respiratory Products

In addition to the requirements of Sections 5.1 through 5.4, the requirements for applicable respiratory products are as follows:

- Full facepiece respirators shall satisfy the goggle requirements of Section 6.
- Loose fitting respirators shall satisfy the face-shield requirements of Section 6.
- Full facepiece welding respirators shall satisfy the goggle requirements of Sections 5.5.3, 6 and 7.
- Loose fitting welding respirators shall satisfy the welding helmet requirements, including marking, of Sections 5.5.3, 6 and 7.

5.6 Replaceable Lenses

5.6.1 Goggles

Round lenses measuring 50 mm (1.97 in.) shall have a dimensional tolerance of ± 0.2 mm (0.007 in.). Rectangular lenses measuring 51 x 108 mm (2.00 x 4.25 in.) shall have a dimensional tolerance of ± 0.8 mm (0.031 in.).

5.6.2 Welding Helmets and Handshields

Rectangular lenses measuring 51 x 108 mm (2.00 x 4.25 in.) and 114 x 133 mm (4.49 x 5.24 in.) shall have a dimensional tolerance of ± 0.8 mm (0.031 in.).

5.7 Aftermarket Components

All original equipment manufacturers (OEM) and non-OEM aftermarket components not sold with the original device shall be tested assembled with the original complete device in the as-worn condition to show compliance with all applicable requirements in Sections 5, 6, 7 and 8. For aftermarket sideshields, the sideshields shall be tested on representative frames for which the product is specified to fit. Documentation listing all devices that the component or accessory

(OEM or non-OEM) has been tested and is approved for shall be made available by the manufacturer.

The entity claiming compliance of the component or accessory is responsible for testing the assembled device and shall provide test results and a list of tested devices upon request.

Except for automatic darkening filters, replacement welding and goggle filters and lenses that meet the size restrictions specified in Section 5.6 shall be tested on one type of representative frame as needed to verify compliance with applicable requirements in Sections 5, 6, 7 and 8.

6. Impact Protector Requirements

6.1 General

6.1.1 Impact Rated Protectors

Impact-rated protectors and replaceable components shall meet the impact requirements in this standard and be marked in accordance with Table 4a and Table 4b.

6.1.2 Frames and Shells

Frames and shells shall meet the requirements for high mass impact and high velocity impact if they are impact-rated. These components shall be tested as a complete device and for frames and shells to be used with prescription lenses, shall be fitted with representative test lenses. Frames and shells are exempt from the penetration requirement.

6.1.3 Lateral (Side) Coverage

When tested in accordance with Section 9.10, impact rated protectors shall provide continuous lateral coverage (i.e. no openings greater than 1.5mm (0.06 in.) in diameter) from the vertical plane of the lenses tangential to a point not less than 10 mm (0.394 in.) posterior to the corneal plane and not less than 10 mm (0.394 in.) in height (or 8 mm (0.315 in.) for the smaller headform) above and not less than 10 mm (0.394 in.) in height (or 8 mm (0.315 in.) for the smaller headform) below the horizontal plane centered on the eyes of the headform. The probe shall not

contact the headform within the defined coverage area. (See Annex D).

6.2 Impact Requirements

6.2.1 Protector Acceptance Criteria

When each type test is conducted as indicated in Sections 6.2.2, 6.2.3 and 6.2.4 and, as applicable Section 6.2.6, a complete device shall fail if any of the following occurs:

- piece fully detached from the inner surface
- fracture
- penetration of the rear surface
- lens not retained
- for the high-velocity test, the unaided eye observes any piece adhering to the contact paste, or observes contact paste on the projectile or complete device.

In the case of plano protectors with a prescription lens carrier, contact of the prescription lens carrier with the headform does not constitute a failure.

6.2.2 High Mass Impact

When tested in accordance with Section 9.11, the complete device shall be capable of resisting an impact from a pointed projectile weighing 500 g (17.6 oz.) dropped from a height of 127 cm (50.0 in.).

6.2.3 High Velocity Impact

When tested in accordance with Section 9.12, the complete device shall be capable of resisting impact from a 6.35 mm (0.25 in) diameter steel ball traveling at the velocity specified in Table 5. No contact with the eye of the headform is permitted as a result of impact.

Table 5. High Velocity Impact Testing

Device type	Velocity
Welding helmets	45.72 m/s (150 ft/s)
Spectacles	45.72 m/s (150 ft/s)
Goggles	76.20 m/s (250 ft/s)
Faceshields	91.44 m/s (300 ft/s)

6.2.4 Penetration Test (lenses only)

When tested in accordance with Section 9.13, lenses for all complete devices shall be capable of resisting penetration by a weighted needle with a total weight of 44.2 gm (1.56 oz.) dropped from a height of 127 cm (50.0 in.).

6.2.5 Prescription Lens Material Qualification

When tested in accordance with Section 9.14, representative test lenses for use in prescription protectors shall be capable of resisting impact from a 6.35 mm (0.25 in.) diameter steel ball traveling at a velocity of 45.72 m/s (150 ft/s). When tested in accordance with this section, the lens shall fail if any of the following occurs:

- posterior displacement of the lens completely through the test holder;
- fracture;
- any detachment of a portion of the lens from its inner surface; or
- any full thickness penetration of a lens.

Failure of any lens constitutes a failure. If all test lenses pass, then any prescription lens of the same or greater thickness at its thinnest point, which is made by the same manufacturer, from the same material, with the same coatings and processes may bear the “+” mark.

6.2.6 Prescription Lens Mounting Qualification

When tested in accordance with Section 9.11 and Section 9.12 complete devices using representative test lenses meeting the requirements of Section 6.2.5 shall be capable of resisting high mass and high velocity impact. For each type of lens retention system offered for sale, one set of 10 complete devices shall be tested. Failure of any device as a result of the six (6) high velocity or four (4) high mass tests shall constitute failure for a set. Failure of a set constitutes failure of that lens retention system.

Lens retention systems are:

- Full rim eyewires that require bevel designs like a “safety V bevel and other lens bevels” for metal frames.

- Full rim eyewires that require bevel designs like a “safety V bevel and other lens bevels” for plastic frames.
- Grooved metal frame style (T-Eyewire)
- Grooved semi rimless with half metal rim and suspension cord mountings
- Three-piece rimless drill mount
- Any mounting that is configured differently than described above to secure the lens and that is design/process dependent such that it requires a different lens beveling process or mounting technique.

Manufacturers shall also conduct the test if it incorporates frames with different lens retention systems into the product offering.

This type testing shall be performed when any substantive change in production occurs that could affect the ability of the device to pass the tests as described in Sections 9.11 and 9.12.

6.3 Additional Impact Requirements for Specific Protector Types

6.3.1 Devices with Lift Fronts

Complete devices with lift fronts shall be impact tested with the lift front in the “up” position.

6.3.2 Welding Helmets and Welding Faceshields

Welding helmets and welding faceshields shall be impact tested as a complete device. If sold as an integrated, complete device, the welding face-shield shall be tested while attached to each of the specified hard hats, bump caps or other head coverings.

6.3.3 Prescription Lens Carriers Behind Plano Protectors

Plano protectors designed to accept prescription lenses held by a prescription carrier behind the plano lenses shall be tested as a complete device, and shall meet the impact requirements in Section 6.2, if the plano protector is impact-rated. Testing shall be done with prescription lenses in powers of -5.00D and +5.00D. Prescription lens carriers used behind plano protectors shall be marked with the manufacturer’s mark or logo but shall not be marked with other Z87 markings.

7. Optical Radiation Protector Requirements

7.1 Transmittance of Lenses

7.1.1 Optional Transmittance Attributes

Claims of compliance to Tables 6, 7, 8 and 9 shall require the protector to bear the appropriate marking.

7.1.2 Clear and Filter Lenses

Plano and prescription lenses shall comply with the applicable transmittance requirements of Tables 6 through 10, and the notes that follow, for clear and filter lenses. Such lenses shall be marked with the appropriate shade or scale marking, in compliance with Table 4a. Measurements shall be taken in accordance with Section 9.2. Clear lenses have a luminous transmission of not less than 85%. Representative test lenses of plano power may be substituted for prescription lenses in this test.

7.1.3 Automatic Darkening Welding Filter Lenses

Automatic darkening welding filter lenses shall comply with the luminous transmittance requirements of Table 6 when tested in both the darkest and lightest designated (marked) dark states in accordance with Section 9.2. Tests for luminous transmittance shall be performed at temperatures of $-5^{\circ}\text{C} \pm 2^{\circ}\text{C}$ ($23^{\circ}\text{F} \pm 3.6^{\circ}\text{F}$), $23^{\circ}\text{C} \pm 2^{\circ}\text{C}$ ($73.4^{\circ}\text{F} \pm 3.6^{\circ}\text{F}$) and $55^{\circ}\text{C} \pm 2^{\circ}\text{C}$ ($131^{\circ}\text{F} \pm 3.6^{\circ}\text{F}$). Tests for UV and IR transmittance shall be performed in the lightest state of the filter (powered or unpowered) at a temperature of $23^{\circ}\text{C} \pm 2^{\circ}\text{C}$ ($73.4^{\circ}\text{F} \pm 3.6^{\circ}\text{F}$).

Measurements shall be taken in accordance with Section 9.2. UV and IR filters shall be assembled within the automatic darkening lens assembly in such a manner that they are not removable by the user. For adjustable automatic darkening welding filter lenses, the dark state tolerance is ± 1 shade number.

7.1.3.1 Switching Index

When tested in accordance with Section 9.15, the switching index from the lightest state of the automatic darkening welding filters to the darkest state of the device shall meet the requirements of

Table 11 when tested at temperatures of $-5^{\circ}\text{C} \pm 2^{\circ}\text{C}$ ($23^{\circ}\text{F} \pm 3.6^{\circ}\text{F}$), $23^{\circ}\text{C} \pm 2^{\circ}\text{C}$ ($73.4^{\circ}\text{F} \pm 3.6^{\circ}\text{F}$) and $55^{\circ}\text{C} \pm 2^{\circ}\text{C}$ ($131^{\circ}\text{F} \pm 3.6^{\circ}\text{F}$).

7.1.3.2 Occlusion

When tested in accordance with Section 9.15, automatic darkening welding filters shall meet the requirements of Table 6 when tested at temperatures of $-5^{\circ}\text{C} \pm 2^{\circ}\text{C}$ ($23^{\circ}\text{F} \pm 3.6^{\circ}\text{F}$), $23^{\circ}\text{C} \pm 2^{\circ}\text{C}$ ($73.4^{\circ}\text{F} \pm 3.6^{\circ}\text{F}$) and $55^{\circ}\text{C} \pm 2^{\circ}\text{C}$ ($131^{\circ}\text{F} \pm 3.6^{\circ}\text{F}$). The filter shall be tested according to

Section 9.15 and shall meet the requirements of Table 11. This shall be true regardless of which sensor or sensors are occluded.

7.1.4 Visible Light Filters

Visible light filters shall meet the transmittance specifications and test methods from ANSI Z80.3-2008 *American National Standard for Ophthalmics - Nonprescription Sunglasses and Fashion Eyewear - Requirements*.

Table 6. Transmittance Requirements for Welding Filters

Shade	Luminous Transmittance			Maximum Effective Far-Ultraviolet Average Transmittance %	Maximum Infrared Average Transmittance %
	Maximum %	Nominal %	Minimum %		
W1.3	85	74.5	67	0.1	<30
W1.5	67	61.5	55	0.1	25
W1.7	55	50.1	43	0.1	20
W2.0	43	37.3	29	0.1	15
W2.5	29	22.8	18.0	0.1	12
W3.0	18.0	13.9	8.50	0.07	9.0
W4	8.50	5.18	3.16	0.04	5.0
W5	3.16	1.93	1.18	0.02	2.5
W6	1.18	0.72	0.44	0.01	1.5
W7	0.44	0.27	0.164	0.007	1.3
W8	0.164	0.100	0.061	0.004	1.0
W9	0.061	0.037	0.023	0.002	0.8
W10	0.023	0.0139	0.0085	0.001	0.6
W11	0.0085	0.0052	0.0032	0.0007	0.5
W12	0.0032	0.0019	0.0012	0.0004	0.5
W13	0.0012	0.00072	0.00044	0.0002	0.4
W14	0.00044	0.00027	0.00016	0.0001	0.3

Notes:

- (1) The near-ultraviolet average transmittance shall be less than one tenth of the minimum allowable luminous transmittance for the associated shade number.
- (2) The blue light transmittance shall be less than the measured luminous transmittance.

7.1.5 Variations in Luminous Transmittance

Measurements shall be taken according to Section 9.2. For shades 1.3 through 3.0, the ratio of the two measured transmittances, one for each lens of a removable pair, or at points directly in front of each eye for a non-removable lens shall not be less than 0.90, nor more than 1.11. For shades 4.0 through 14 inclusive, the ratio of the two measured transmittances, shall be not less than 0.80 nor more than 1.25. Variation in transmission shall be measured in the darkest state. For prescription lenses, the same requirements apply, except when variations are due to thickness variations based on the lens design.

7.2 Transmittance of Housings**7.2.1 Goggles**

Housings of goggles intended to provide protection against optical radiation shall meet the transmittance requirements for Shade 6 or higher.

7.2.2 Faceshields

Housings of faceshields intended to provide protection against optical radiation shall meet, at a minimum, the transmittance requirements for the shade or scale number specified by the manufacturer.

Table 7. Transmittance requirements for Ultraviolet Filters

Scale	Maximum Effective Far-Ultraviolet Average Transmittance %	Maximum Near Ultra-Violet Average Transmittance %	Transmittance in the infra-red spectral range	Blue Light Transmittance
U2	0.1	3.7	no requirement	no requirement
U2.5	0.1	2.3	no requirement	no requirement
U3	0.07	1.4	no requirement	no requirement
U4	0.04	0.5	no requirement	no requirement
U5	0.02	0.2	no requirement	no requirement
U6	0.01	0.1	no requirement	no requirement

Table 8. Transmittance requirements for Infrared Filters

Scale	Maximum Infrared Average Transmittance %	Blue Light Transmittance
R1.3	<30	no requirement
R1.5	25	no requirement
R1.7	20	no requirement
R2	15	no requirement
R2.5	12	no requirement
R3	9	no requirement
R4	5	no requirement
R5	2.5	no requirement
R6	1.5	no requirement
R7	1.3	no requirement
R8	1.0	no requirement
R9	0.8	no requirement
R10	0.6	no requirement

Table 9. Transmittance requirements for Visible Light Filters

Scale	Maximum %	Nominal %	Minimum %
L1.3	85	74.5	67
L1.5	67	61.5	55
L1.7	55	50.1	43
L2	43	37.3	29
L2.5	29	22.8	18
L3	18	13.9	8.5
L4	8.5	5.18	3.16
L5	3.16	1.93	1.18
L6	1.18	0.72	0.44
L7	0.44	0.27	0.164
L8	0.164	0.10	0.061
L9	0.061	0.037	0.023
L10	0.023	0.0139	0.0085

Table 10. Transmittance Requirements for Special-Purpose Lenses

Lens Type	LUMINOUS TRANSMITTANCE		*Ratio [R] of measured Luminous Transmittance
	% Maximum	% Minimum	
Tinted	<85	8	$0.90 \leq R \leq 1.10$
Extra Dark	<8	0.2	$0.8 \leq R \leq 1.20$

*R is the ration of the two measured transmittances, one for each lens of a pair, or at points directly in front of each eye for a single lens.

Table 11. Switching Index Requirements for Automatic Darkening Welding Filter Lenses

	LIGHT SHADE NUMBER						
	1.7	2.0	2.5	3.0	4.0	5.0	6.0
DARK SHADE NUMBER	Switching	Index (ms)					
W7	300	400	500	700	1000	-	-
W8	100	150	200	300	500	1000	-
W9	40	50	70	100	200	400	700
W10	20	20	30	40	70	100	300
W11	6	7	10	15	30	50	100
W12	2	3	4	5	10	20	40
W13	0.8	1	1.5	2	4	7	10
W14	0.3	0.4	0.5	0.7	1	3	5

8. Droplet and Splash, Dust, and Fine Dust Protector Requirements

8.1 Droplet and Splash Hazard

8.1.1 Goggles

When tested in accordance with Section 9.16.1, the droplets and/or liquid splash shall not cause a red coloration within either of the two circles described in the test method. No account shall be taken of any such coloration up to a distance of 6 mm (0.24 in.) inside the edges of the protector.

8.1.2 Faceshields

When tested in accordance with Section 9.16.2, the laser beam shall not make direct contact with any point on the eye-region rectangle without first being intercepted by the faceshield.

8.2 Dust Hazard

When tested in accordance with Section 9.17, the ratio of the mean reflectance after exposure in the dust chamber to the mean reflectance before exposure shall not be less than 0.80.

8.3 Fine Dust Hazard

When tested in accordance with Section 9.18, no red coloration shall be observed on the test paper under the protector. No account shall be taken of any such coloration up to a distance of 6 mm (0.24 in.) inside the edges of the protector.

9. Test Methods

Testing shall be performed on the number of complete devices specified within the test sections below and summarized in Annex A. Unless otherwise specified, all tests shall be performed at standard laboratory conditions (23 ± 5 °C, 50 % RH ± 15 %). In many tests, devices are mounted on one of two headforms of the type defined by EN 168:2001, Section 17 and referenced in Annex B. When testing a protector, the appropriate sized headform (medium or small) shall be used throughout the testing protocol.

Alternative measurement methods are acceptable if shown to perform equivalently to the reference test methods cited in this section.

9.1 Optical Quality Test

9.1.1 Purpose

This test is intended to determine that the lenses are free of visible defects which would impair their optical quality.

9.1.2 Apparatus and Procedure

The apparatus and procedures specified in Z80.1-2005 *American National Standard for Ophthalmics - Prescription Ophthalmic Lenses - Recommendations* shall be used to determine the lenses optical quality. All lenses of one complete device shall be tested.

9.2 Transmittance Test

9.2.1 Purpose

This test is intended to measure the ultraviolet, luminous, infrared and blue-light, normal transmittance of lenses.

9.2.2 Apparatus and Procedure

The transmittance may be determined by any suitable method, but the reference method shall be the use of a spectrophotometer and calculation using appropriate weighting factors given in Tables C1 through C4 of Annex C. All lenses of one complete device shall be tested.

9.3 Haze Test

9.3.1 Purpose

This test is intended to measure the haze in clear lenses.

9.3.2 Apparatus and Procedure

The apparatus and procedures specified in ASTM D1003-00, *Test Method for Haze and Luminous Transmittance of Transparent Plastics*, shall be used to measure the haze. The illuminant used shall be CIE illuminant A. All lenses of one complete device shall be tested.

9.4 Refractive Power, Astigmatism and Resolving Power Tests

9.4.1 Purpose

These tests are intended to determine that the protectors meet the optical requirements for refractive power, astigmatism and resolving power of

this standard.

9.4.2 Apparatus

The apparatus shall consist of a calibrated 8 power telescope having a minimum aperture of 19 mm (0.75 in.) for plano-spherical lenses and a minimum aperture of 7 mm (0.276 in.) for plano-toric or plano-aspheric lenses, a means of holding the protector in the test position, a sunburst test pattern, Figure E5, and a high contrast test pattern from NBS Special Publication 374, (See Annex G for source). The test patterns shall be interchangeable and mounted 10.67 m (35 ft) from the objective lens of the telescope. Calibration methods for the telescope are given in Annex F.

9.4.3 Procedure

The telescope and observer shall be qualified by resolving pattern 20 of the high contrast test pattern when no lens is in front of the telescope. The telescope shall then be focused on the sunburst test pattern. Except for faceshield windows, the lens shall be positioned as worn with the primary line of sight coincident with the axis of the telescope. For faceshield windows, the holder shall be positioned such that the axis of the telescope passes without occlusion through the window. All lenses of one complete device shall be tested.

The distance between the lens being tested and the objective lens of the telescope shall not exceed 38 mm (1.5 in.). The telescope is then re-focused on the radial lines until they appear as sharp as possible. Two possibilities may then occur, all or just some of the lines will appear well focused.

If all radial lines appear equally well-focused at the same position of the focus wheel, the lens has no measurable astigmatism and the power reading of the telescope is the refractive power of the test lens.

If lines in only one meridian appear sharpest at a given focus, then the telescope shall be re-focused to determine the best focus for the lines in the meridian which yield an extreme (maximum or minimum) power reading. The power reading shall be noted. The telescope shall be then re-focused for lines in the meridian which

yields the opposite extreme power reading. The second power reading shall be noted. The astigmatism shall be calculated as the absolute value of the algebraic difference between the two extreme power readings.

The telescope shall then be re-focused for the best compromise focus, that is, until all radial lines appear equally sharp. The sunburst test pattern shall be replaced with the high contrast test pattern. The observer shall attempt to resolve all lines of pattern 20 in both orientations without re-focusing the telescope.

9.5 Prismatic Power Test

9.5.1 Purpose

This test is intended to measure the prismatic power and prismatic imbalance of a protector.

9.5.2 Apparatus

This apparatus shall consist of the headform which has been modified by boring two through holes at least 19.0 mm (0.75 in) diameter centered on each eye. The headform shall be placed in an optical system as shown in Figure E6. The telescope lens, L2, shall be located at a distance of 1.0 m (39.4 in.) in front of image plane, IP. The pinhole aperture plate, p, shall be located approximately 1.0 m (39.4 in.) from the collimator lens, L1, and shall be adjusted so that one image is formed on the image plane, IP, when no protector is on the headform. The position of that image shall be marked or noted and will be called Po.

9.5.3 Procedure

The complete device shall be placed on the headform in the designed wearing position, without having changed the spacing of the optical system. The image(s) on the image plane shall be identified as coming from the right eye, Pr, or the left eye, Pl, by blocking the beams of each eye. The distance in centimeters between the centers of Pl and Po and Pr and Po shall be measured. The prismatic power of the protector in prism diopters (Δ) is determined by measuring the distance in centimeters between Po and Pl or Po and Pr, whichever is greater. The horizontal and vertical distances in centimeters between the centers of Pl and Pr shall be measured.

The horizontal prism imbalance of the protector in prism diopters shall be the horizontal distance measured in centimeters between Pl and Pr. The vertical prism imbalance of the protector in prism diopters shall be the vertical distance measured in centimeters between Pl and Pr. The “base” of the horizontal prism imbalance shall be determined by looking at the image plane (looking at the image plane from the headform). If the right-most image comes from the right eye of the headform, then the prism imbalance is “base out”. If the left-most image comes from the right eye of the headform, then the prism imbalance is “base in”. One complete device shall be tested.

9.6 Drop Ball Test

9.6.1 Purpose

This test is intended to ensure that all protectors possess a minimum impact resistance.

9.6.2 Procedure

Each complete device tested shall be placed on the headform as it would be worn by the user. For faceshields, an additional supporting block, approximately 25.4 mm (1.0 in.) wide and curved to conform to the shape of the window, shall be provided as a support for the window at its lower end but not lower than the chin of the headform. The alignment shall be such that when the ball is dropped, it is in line with either of the eyes of the headform.

A 25.4 mm (1 in.) diameter steel ball, weighing 68 g (2.4 oz) shall be freely dropped from a height of 127 cm (50 in.) onto the lens at a point in line with the eyes of the headform. Four complete devices shall be tested for each lens material and coating, two on the left viewing area and two on the right viewing area.

9.7 Ignition Test

9.7.1 Purpose

This test is intended to determine the protector’s resistance to ignition as worn.

9.7.2 Apparatus

The test apparatus shall consist of a steel rod measuring, 300 ± 3 mm (11.81 ± 0.12 in.) long and 6 mm (0.24 in.) nominal diameter with end faces that are flat and cut perpendicular to the

longitudinal axis, a heat source capable of temperatures of at least 650°C (1202°F), a thermocouple and temperature indicating device, and a timer with 0.1s uncertainty of measurement.

9.7.3 Procedure

Attach the thermocouple to the rod at a distance of 20 ± 1 mm (0.79 ± 0.04 in.) from the end of the rod. Heat that end of the steel rod over a length of 50 mm (1.97 in.) to a temperature of 650 ± 20 °C (1202 ± 68 °F).

Press the heated face of the rod against a surface of the protector (the contact force being equal to the weight of the rod) for 5.0 ± 0.5 seconds, and then remove it.

Repeat with each additional externally exposed part of the protector as worn, until all external surface materials (excluding elastic bands or textiles) have been tested. One complete device shall be tested.

9.8 Corrosion Resistance Test

9.8.1 Purpose

This test is intended to determine the capability of metal components of a protector to resist corrosion.

9.8.2 Apparatus

The test apparatus shall consist of a boiling saline solution and a room temperature saline solution both in containers of sufficient dimensions to submerge the metal parts. The saline solutions shall contain 10% by weight of sodium chloride in water prior to heating.

9.8.3 Procedure

Metal parts shall be submersed in the boiling saline solution for a period of fifteen minutes. The parts, upon being removed from the boiling solution, shall be immediately immersed in the room temperature saline solution. They shall then be removed from this solution, and without having the adhering liquid wiped off, allowed to dry for twenty-four hours at room temperature. The metal parts shall then be rinsed in lukewarm water and allowed to dry. One complete device shall be tested.

9.9 Light Tightness Test

9.9.1 Purpose

This test is intended to determine light sealing capabilities between the lens and the lens holder of welding protectors.

9.9.2 Apparatus

The apparatus shall consist of a system capable of illuminating the entire lens retaining area and confining the light to the exterior surface of the protector. An example is shown in Figure E3. A shade 14 lens shall be used to test for light leakage. Automatic darkening filter lenses shall be tested with the viewing area covered with an opaque material.

9.9.3 Procedure

The welding protector shall be held firmly against the seal of the test apparatus and examined for direct light leakage between the lenses, gaskets or other components. The test shall be performed in a darkened room to verify a light tight design when viewed from any angle. One complete device shall be tested.

9.10 Lateral Protection Test

9.10.1 Purpose

The test is intended to assess the lateral protection area of a complete device.

9.10.2 Apparatus

The apparatus shall consist of the headform and a probe device such as a rod of 1.5 mm (0.06 in.) nominal diameter, 125 mm long (4.9 in.) (nominal). Other suitable probes may be used, but this is the reference method. Protectors marked with an "H" or intended for smaller anatomical dimension shall be tested on the smaller headform.

9.10.3 Procedure

The complete device shall be placed on the headform in the designated wearing position. The probe shall be directed horizontally to contact six (6) lateral positions on the complete device:

a. Anywhere within the coverage area defined in Section 6.1.3 and including a point 10 mm above (8 mm (0.315 in.) above for the smaller headform) the horizontal plane at 90° (temporal) to each eye (three test locations).

b. Anywhere within the coverage area defined in Section 6.1.3 and including a point 10 mm below (8 mm (0.315 in.) below for the smaller headform) the horizontal plane at 90° (temporal) to each eye (three test locations).

One complete device shall be tested.

9.11 High Mass Impact Test

9.11.1 Purpose

This test is intended to determine the capability of a protector to resist impact from relatively heavy, pointed objects traveling at low velocity.

9.11.2 Apparatus

The headform shall be used to hold the complete device. It shall be rigidly mounted in the horizontal position, face up, on a base which has a mass of 30 kg (66 lb) or greater. The static stiffness of the headform shall be such that when a vertical downward force of 20 kg (44 lb) is applied to the forehead of the headform, the back of the headform shall not deflect more than 2 mm (0.08 in.). The missile shall be made of steel and shall have a 30° conical tip with a 3.175 mm (0.125 in) spherical radius, shall weigh a minimum of 500 g (17.6 oz.), and have a diameter of 25.4 mm (1.0 in), as shown in Figure E4. The missile will be held in position over the headform, tip down, at the designated test height of 1270 mm (50.0 in.). The missile may have a hardened steel tip. Care shall be taken to maintain the tip configuration and weight of the missile.

The missile shall be dropped through a loose-fitting guide tube having a smooth internal diameter; this prevents missile tumble while not retarding free fall. Shielding around the headform is required to protect the operator.

9.11.3 Procedure

Testing shall be performed on the complete protector with its non-removable lenses or representative test lenses. A new and complete device is placed on the headform as it was designed to be worn. The alignment shall be such that when the missile is dropped, its point is in line with the center of either of the eyes of the headform. To protect the operator, the guide tube shall be positioned so that the lower end of the tube is 180

mm (7.1 in.) from the point of impact.

Four complete devices shall be tested within a 20 mm (0.788 in.) circle centered in front of each eye of the headform, two on the left viewing area and two on the right viewing area.

9.11.3.1 Spectacle frames intended for prescription removable lenses shall be equipped with representative test lenses for testing. The representative test lenses shall be 2.0 mm + 0.2mm - 0.0 mm (0.079 in. +0.008 in. - 0.0 in.) thick at their thinnest point, and have plano power.

9.11.3.2 For each prescription lens retention system 4 complete devices shall be tested.

9.11.3.3 For prescription lens carriers, four complete devices equipped with prescription lenses mounted behind the plano lens(es) shall be tested. The carriers shall be fitted with a total of 4 lenses of -5.0 D and a total of 4 lenses of +5.0 D.

9.12 High Velocity Impact Test

9.12.1 Purpose

This test is intended to determine the capability of a protector to resist impact from high velocity, low mass projectiles.

9.12.2 Apparatus

The test apparatus shall consist of the headform mounted vertically within an enclosure and a mechanism capable of propelling a 6.35 mm (0.25 in.) diameter steel ball weighing 1.06 g (0.037 oz) reproducibly at velocities from 45.7 to 91.4 m/s (150 to 300 ft/s) at the headform. Protectors marked with an "H" or intended for smaller anatomical dimensions shall be tested on the smaller headform.

The headform shall be capable of being rotated about the vertical axis specified in Section 9.12.3 in 30° increments, from a first position which is directly normal and centered to an eye of the headform to 90° temporally. The headform shall be capable of being raised and lowered 10 mm (0.394 in) for the headform, or 8 mm (0.315 in.) for the smaller headform with respect to the horizontal reference plane formed by the center of the

eyes of the headform to carry out spatial testing of frontal and temporal positions. Mass of the test headform shall be at least 4 kg (8.8 lb.).

The velocity of the steel ball shall be determined at a distance not greater than 25 cm (9.8 in.) from the eye of the headform and shall have a standard deviation not exceeding 2% of the specified test velocity over a test series of 30 shots.

Information about a typical High Velocity Impact Test Apparatus is given in Annex E

9.12.3 Procedure

Testing shall be performed on the complete protector with its non-removable lenses or representative test lenses. Apply a thin layer of white contact paste to each of the eyes of the headform covering an area 25 mm (1.0 in.) in diameter centered on the corneal vertex of the eye. A new and complete device shall be mounted on the headform in the manner in which the protector was designed to be worn. The headform shall be adjusted so that the path of the projectile passes through the center of the anterior surface of either of the eyes of the headform. The headform is then rotated on an axis which passes vertically at the intersection of a sagittal plane through the center of the front surface of the tested eye and a corneal (frontal) plane which is 10 mm (0.394 in.) posterior to the corneal plane which is tangent to the anterior surfaces of the eyes of the headform, and/or raised or lowered 10 mm (0.394 in.) in height (or 8 mm for the smaller headform) to align with each test position. A new complete device is impacted at the test velocity as specified in Section 6.2.3. The balls are damaged during impact and should be changed frequently to avoid impacts at unexpected locations and large variations in velocity.

Six impact sites shall be tested for each type of protector:

- a. a point along the horizontal plane of the center of the eye of the headform, and within a 10 mm (0.394 in.) diameter circle centered directly in front of each eye of the headform. (Two total test sites)
- b. within a 5 mm (0.197 in.) diameter circle centered on a point on the horizontal plane of

- each eye at +30° (temporal). (Two total impact sites).
- c. within a 5 mm (0.197 in.) diameter circle centered on a point 10 mm (0.394 in.) above the horizontal plane of the eye at +90°(temporal) to one eye. If the frames are marked with an “H”, the impact point shall be within a 5 mm (0.197 in.) diameter circle centered 8 mm (0.315 in.) above the horizontal plane of the eye +90° (temporal) to one eye. (One total impact site)
 - d. within a 5 mm (0.197 in.) diameter circle centered on a point 10 mm (0.394 in.) below the horizontal plane of the eye at +90°(temporal) to the opposite eye of that used in c above. If the frames are marked with an “H”, the impact point shall be within a 5 mm (0.197 in.) diameter circle centered 8 mm (0.315 in.) below the horizontal plane of the eye +90° (temporal) to the opposite eye of that used in c above. (One total impact site).

A total of six complete devices shall be tested.

9.12.3.1 Spectacle frames intended for prescription removable lenses shall be equipped with representative test lenses. The representative test lenses shall be 2.0 mm +0.2mm -0.0 mm (0.079 in. +0.008 in. -0.0 in.) thick at their thinnest point.

9.12.3.2 For each prescription lens retention system, six complete devices shall be tested for each lens retention system.

9.12.3.3 For prescription lens carriers, a new and complete device shall be used for each impact point noted above for a + 5.00 D lens and a new and complete device shall be used for each impact point noted above for a – 5.00 D lens. A total of twelve (12) devices shall be tested for prescription lens carrier frames, two devices impacted at each site.

9.13 Penetration Test

9.13.1 Purpose

This test is intended to determine the capability of a lens to resist penetration by a low mass pointed projectile.

9.13.2 Apparatus

The test apparatus shall consist of a pointed projectile consisting of a new 135 x 17 needle fastened into a holder, weighing 44.2 g (1.56 oz). The projectile shall be dropped through a loose-fitting guide tube having a smooth internal diameter; this prevents projectile tumble while not retarding free fall. A new needle shall be used for each drop of the needle penetration test.

The headform shall be used to hold the complete device. It shall be rigidly mounted in the horizontal position, face up, on a base which has a mass of 30 kg (66 lb) or greater. The static stiffness of the headform shall be such that when a vertical downward force of 20 kg (44 lb) is applied to the forehead of the headform, the back of the headform shall not deflect more than 2 mm (0.08 in.).

For faceshields, an additional supporting block, approximately 25.4 mm (1.0 in.) wide and curved to conform to the shape of the window, shall be provided as a support for the window at its lower end but not lower than the chin of the headform. Shielding around the headform is required to protect the operator.

9.13.3 Procedure

The projectile shall be freely dropped through the guide tube, point downward, from a height of 127 cm (50 in.) onto the horizontal outer surface of the lens. Four complete devices shall be tested within a 20 mm (0.788 in.) circle centered in front of each eye of the headform, two on the left viewing area and two on the right viewing area. To protect the operator, the guide tube shall be positioned so that the lower end of the tube is 102 mm (4.0 in.) from the point of impact.

For faceshields, the window shall be placed in a horizontal position such that the axis of the window is horizontal and the outer surface of the window is facing upward. The projectile shall be dropped onto a point in line with the eyes of the headform.

All other complete devices shall be placed on the headform as it would be worn by the user. The alignment shall be such that when the projectile is dropped, its point is in line with either of the eyes of the headform.

9.14 Prescription Lenses Test

9.14.1 Purpose

This test is intended to determine the ability of prescription lens materials and individual coatings and processes applied to those materials to withstand impact from high velocity, low mass projectiles.

9.14.2 Procedure

Plano power lenses, maximum base curve of 6.25 diopter, shall be edged round with a uniform $115^{\circ} \pm 5^{\circ}$ included angle bevel to a diameter $55.0 \text{ mm} +0.04 \text{ mm}/-0.25 \text{ mm}$ ($2.17 + 0.002/-0.01$ in.). Each lens shall be tested once, with a new lens used for each additional impact. Each lens shall be mounted in a steel test holder by two retaining washers so that the test lens is held firmly against the bevel of the lens holder (See Figure E7). Perform the high velocity impact test on the center of each lens with the missile and velocity determination specified in Section 9.12 at a velocity of 45.7 m/s (150 ft/s). Three lenses shall be tested.

9.15 Switching Index Test

9.15.1 Purpose

This test is intended to determine the switching index of an automatic darkening filter lens which requires the measurement of luminous transmittance over time as the device is exposed to optical radiation from a test light source.

9.15.2 Apparatus

The following test apparatus, or an equivalent apparatus capable of determining compliance with Table 11, shall be used. The response time of the test apparatus (between 10% and 90% of recorded peak light intensity) shall be no greater than 10% of the required switching index of the lens under test. The test apparatus shall consist of a light source, detector, trigger light source and a recording device.

The light source shall be a high intensity collimated light source which, when optically coupled to an associated light detector, provides the required intensity to measure the luminous transmittance of the lens under test in its highest shade number state.

The detector shall have a calibrated photopic response, which, when coupled with an associated light source, is capable of measuring the luminous transmittance of the lens under test in its highest shade number state.

The trigger light source shall be a high intensity light source of at least 10,000 lux capable of being either electronically or mechanically switched on. The recording device shall be a storage oscilloscope or equivalent instrument capable of recording the output of the detector, in time, and providing output functions of normal transmittance and time.

9.15.3 Procedure

The automatic darkening welding filter shall be maintained at the appropriate test temperature for a minimum of 2 hours before testing and during the period of test. Ambient lighting conditions during testing shall not exceed 16 lux. All but any one sensor of the automatic darkening welding filter shall be occluded with opaque material.

The automatic darkening welding filter and light detectors shall be mounted normal to the beam of illumination. Solar or photoelectric power cells shall be shielded from the transmittance light source beam.

Methods shall be employed to ensure that the temperature of the lens under test does not exceed the prescribed test temperature (For example: due to exposure from the transmittance light source).

With the transmittance light source activated, the trigger light source shall be switched to its high illumination state. The luminance variations over time, both of the triggering light source at the filter and the transmittance light source through the filter, shall be recorded.

The switching index shall be calculated using the equation given in Section 3, and setting $t=0$ as the time when the recorded trigger source illuminance reached 5000 lux.

Repeat test as necessary until all sensors on the device have been tested individually (with others occluded). One complete device shall be tested.

9.16 Droplet and Splash Test

9.16.1 Goggles

9.16.1.1 Purpose

This test is intended to determine the capability of the protector to keep liquid splashes or sprays from reaching the wearer's eyes. This is not intended to evaluate the fit of the protector to the wearer's face. (See Annex J.11)

9.16.1.2 Apparatus

A spray solution, 0.1 mol/L solution of sodium carbonate in water shall be prepared and placed in a hand-operated atomizer, capable of producing fine droplets (not mist).

The detection/test area on the headform shall be defined by white blotting paper of sufficient size to cover the lens area and extend at least 20 mm (0.79 in.) beyond the periphery of the protector to be tested and marked with two circles of 52 mm (2.05 in.) diameter centered over each eye. If smaller sized protectors with the "H" designation are to be tested, the smaller headform shall be used and the blotting paper is to be marked with two circles of 48 mm (1.89 in) diameter centered over each eye. Absorbent cotton lint (surgical dressing), mass per unit area $\sim 185 \text{ g/m}^2$ is used to fit the protector more securely against the headform.

For this test, a detection solution, prepared by dissolving $5.0 \pm 0.5 \text{ g}$ phenolphthalein in $500 \pm 50 \text{ ml}$ ethanol and adding $500 \pm 50 \text{ ml}$ water, shall be prepared and stirred constantly (filter if precipitate forms) to obtain $1.0 \pm 0.1 \text{ L}$ of solution.

9.16.1.3 Procedure

Cover the lens region of the headform with layers of cotton lint. Dip the blotting paper in the detection solution described in Section 9.16.1.2 and shake off excess. Place the moist blotting paper over the lint, centering the circles over each eye.

Fit the protector onto the headform in the normal wearing position so that the blotting paper protrudes all around its periphery by at least 20 mm (0.79 in.). Adjust the headband to a normal degree of tension. Adjust the number of layers of lint, as necessary, to ensure a good seal between

the protector and the headform.

Spray the mounted protector with approximately 5 - 10 ml of the spray solution, holding the atomizer at a distance of approximately 600 mm (23.6 in.) from the headform and spraying from all directions. All the blotting paper around the periphery should turn a uniform crimson color. The blotting paper shall not be over-wetted such that it drips. Examine the blotting paper for intrusion of color into the circles. One complete device shall be tested.

9.16.2 Faceshields

9.16.2.1 Purpose

This test is intended to determine the capability of a faceshield to keep liquid splashes or sprays from reaching the wearer's eyes by observing the area of coverage of the faceshield.

Note: the observation method describes the use of a laser beam; alternatively, observations may be made by viewing through a cylindrical tube fitted with cross-wires

9.16.2.1 Apparatus

A headform shall be used and marked with the rectangle ABCD around the eye area as shown in Figure B1.

The marked headform shall be mounted on a stage that allows at least 45° rotation about the horizontal axis positioned at the level of the eyes of the headform, and at least 90° rotation left and right around a vertical axis centered between the eyes of the headform. An exemplary stage for mounting and rotation is shown in Figure E8.

A visible laser beam with a maximum beam diameter of 5 mm is used as the light source for observation. The laser shall be mounted to allow vertical movement up or down but no rotation about its horizontal or vertical axes.

9.16.2.3 Procedure

Position the laser beam to intersect the headform at the mid-point of the horizontal line joining the eye centers. Temporarily block the laser beam, and fit the faceshield onto the headform in accordance with the manufacturer's instructions.

Project the laser beam at all accessible points within the eye-region rectangle when the headform is set to the following positions:

- 1) Headform facing forward and rotated $45^\circ \pm 1^\circ$ forward about the horizontal axis.
- 2) Headform facing forward and rotated $45^\circ \pm 1^\circ$ backward about the horizontal axis.
- 3) Headform rotated $90^\circ \pm 1^\circ$ to the left about the vertical axis, and rotated $45^\circ \pm 1^\circ$ forward about the horizontal axis.
- 4) Headform rotated $90^\circ \pm 1^\circ$ to the left about the vertical axis, and rotated $45^\circ \pm 1^\circ$ backward about the horizontal axis.
- 5) Headform rotated $90^\circ \pm 1^\circ$ to the right about the vertical axis, and rotated $45^\circ \pm 1^\circ$ forward about the horizontal axis.
- 6) Headform rotated $90^\circ \pm 1^\circ$ to the right about the vertical axis, and rotated $45^\circ \pm 1^\circ$ backward about the horizontal axis.

Observe whether the beam is intercepted by the faceshield before it makes contact with any point on the eye-region rectangle. Record as a failure any location where laser beam contacts the rectangle without first intercepting the faceshield.

9.17 Dust Test

9.17.1 Purpose

This test is intended to determine the capability of the protector to keep large dust particles from reaching the wearer's eyes. This is not intended to evaluate the fit of the protector to the wearer's face. (See Annex J.11)

9.17.2 Apparatus

An enclosed dust chamber with glass front and nominal dimensions of 560 x 560 x 560 mm (22 x 22 x 22 in.), with a hopper-shaped base and a tightly sealed, hinged lid shall be used. A blower is connected to the bottom of the hopper and is capable of delivering $\sim 2.8 \text{ m}^3/\text{min}$ at a pressure of 2,250 Pa. A suitable agitator capable of inducing swirling in the air stream from the blower should be placed immediately above the air inlet. The dust chamber is equipped with an upper outlet that is connected to the blower inlet for recirculation. The chamber is fitted with bars to support a headform, with the spacing of the bars sufficient to allow free circulation of the dust within

the chamber.

Test dust, 1000 \pm 50 g of pulverized coal, shall be placed in the chamber. The coal dust shall have the following particle size distribution:

Nominal sieve mesh dimension, mm	Minimum % passed through sieve
0.300	95%
0.150	85%
0.090	40%
0.040	3%

The detection/test area on the headform shall be defined by white blotting paper of sufficient size to cover the lens area and extend at least 20 mm (0.79 in.) beyond the periphery of the protector to be tested and marked with two circles of 52 mm (2.05 in.) diameter centered over each eye. If smaller sized protectors with the "H" designation are to be tested, the smaller headform shall be used and the blotting paper is to be marked with two circles of 48 mm (1.89 in) diameter centered over each eye. Absorbent cotton lint (surgical dressing), mass per unit area $\sim 185 \text{ g/m}^2$ is used to fit the protector more securely against the headform.

The test measurement device shall be a photoelectric reflectometer, incorporating a light source radiating energy within the visible range and a detector sensitive only to the visible range, with peak sensitivity in the green region.

A white comparison sample, capable of constant reflectance during the duration of the test (e.g., opal glass, ceramic tile, pressed barium sulfate, magnesium carbonate block, several thicknesses of clean white paper, etc.) shall be used as a test reference.

9.17.3 Procedure

Soak the blotting paper in water, and then shake off any excess. Using the reflectometer, measure the reflectance of each of the two circles on the wet blotting paper and on the white comparison sample. Calculate the starting mean reflectance value of the two circles, relative to the value of the white reference.

Cover the headform with layers of absorbent cotton lint. Place the sheet of moist white blotting paper over the lint, with the marked circles centered over the eyes of the headform. Mount the protector on the headform. Adjust the headband to a normal degree of tension. Adjust the number of layers of lint, as necessary, to ensure a good seal between the protector and the headform.

Place the headform in the dust chamber, close the chamber, and operate the blower for 60 ± 2 seconds. Allow the dust chamber to remain undisturbed for 30 ± 2 minutes, then remove the headform. Carefully remove the blotting paper from the headform, ensuring that no additional dust is deposited on the areas of the circles.

Within 2 minutes of removal, re-measure the reflectance of the two circles relative to the white comparison sample. Calculate the final mean reflectance value. One complete device shall be tested.

9.18 Fine Dust Particle Test

9.18.1 Purpose

This test is intended to determine the capability of the protector to keep fine dust particles from reaching the wearer's eyes. This is not intended to evaluate the fit of the protector to the wearer's face. (See Annex J.11)

9.18.2 Apparatus

An enclosed gas-tight chamber with glass front and nominal dimensions of 560 x 560 x 560 (22 x 22 x 22 in.) shall be used. The gas chamber shall be ventilated by means of a blower capable of delivering $\sim 1.4 \text{ m}^3/\text{min}$ and equipped with a vent pipe leading to a suitable gas removal/treatment system.

The detection/test area on the headform shall be defined by white blotting paper of sufficient size to cover the lens area and extend at least 20 mm (0.79 in.) beyond the periphery of the protector to be tested and marked with two circles of 52 mm (2.05 in.) diameter centered over each eye. If smaller sized protectors with the "H" designation are to be tested, the smaller headform shall be used and the blotting paper is to be marked with two circles of 48 mm (1.89 in) diameter centered

over each eye. Absorbent cotton lint (surgical dressing), mass per unit area $\sim 185 \text{ g/m}^2$ is used to fit the protector more securely against the headform.

For the test, a supply of ammonia gas is connected to the gas chamber. Suitable supplies include ammonia gas cylinders, or bubbling air through a wash bottle containing a concentrated ($\sim 0.9\text{g/ml}$ water) solution of ammonia. The detection solution shall be prepared by dissolving $5.0 \pm 0.5 \text{ g}$ phenolphthalein in $500 \pm 50 \text{ ml}$ ethanol and adding $500 \pm 50 \text{ ml}$ water, stirring constantly (filter if precipitate forms) to obtain $1.0 \pm 0.1 \text{ L}$ of solution.

9.18.3 Procedure

Cover the headform with several layers of absorbent cotton lint. Dip the white blotting paper into the detecting solution, shaking off any excess. Mount the moist paper over the lint, and then mount the protector on the headform. Adjust the headband to a normal degree of tension. Adjust the number of layers of lint, as necessary, to ensure a good seal between the protector and the headform.

Place a separate test strip of blotting paper dipped in detection solution on the floor of the chamber. Place the headform in the chamber. Open the chamber vent very slightly, then slowly introduce ammonia gas to fill the chamber. When the test strip changes to a crimson color, close the vent and leave the headform in the closed chamber for $5.0 \pm 0.2 \text{ min}$.

At the end of this time, evacuate the chamber thoroughly by operating the blower. After the chamber has cleared of ammonia, remove the headform. Examine the test paper for coloration. One complete device shall be tested.

10. Instructions, Use and Maintenance

10.1 General

Eye and face protection shall be required where there is a reasonable probability of injury that can be prevented by such equipment. In such cases, employers and educational authorities shall make conveniently available a protector for the work

environment, per applicable federal and state regulations. Employees and students shall use such protectors.

Annex I contains a Selection Chart, which will be helpful in deciding types of protectors that are available, their capabilities and limitations. It should be recognized that dusty or chemical environments or both might represent an additional hazard to contact lens wearers. Wearers of contact lenses shall be required to wear appropriate eye and face protectors in a hazardous environment.

10.2 Instructions

Employers and educational authorities shall provide employees and students with all warnings, cautions, instructions and limitations provided with the protector by the manufacturer and inform wearers as to their meaning.

10.3 Inspections

Employees and students shall make a visual inspection of their protector prior to each use. Protectors which exhibit broken parts, distortion, or excessive scratches on the lens, are unsuitable for use and shall not be worn. Eye and face protectors that have been subject to an impact shall not be used and shall be discarded and replaced.

10.4 Maintenance

Protectors shall be maintained in a usable condition in accordance with the manufacturer's instructions.

When one protector is being used by more than one person, it is recommended that it be cleaned and disinfected prior to use by another person.

10.5 Care

Reasonable care shall be taken during the use and storage of protectors so that they are not subject to unnecessary abuse.

10.6 Training

Employers and educational authorities shall train employees and students in the proper use, application, inspection, maintenance, storage, fitting and limitations of eye and face protectors.

Annex A: Samples for Testing
(normative)

Reference Section	Test Attribute	Quantity for Testing
5.1.5	Refractive Power, Astigmatism, Prism and Prism Imbalance (Rx)	100% testing
9.1	Optical Quality	1
9.2	Transmittance	1
9.3	Haze	1
9.4	Refractive Power, Astigmatism, and Resolving Power (plano)	1
9.5	Prismatic Power	1
9.6	Drop Ball	4
9.7	Ignition	1
9.8	Corrosion Resistance	1
9.9	Light Tightness	1
9.10	Lateral Protection	1
9.11	High-Mass Impact (plano)	4
9.11	High-Mass Impact (Rx)	4
9.12	High-Velocity Impact (plano)	6
9.12	High-Velocity Impact (Rx)	6
9.12	High-Velocity Impact (Rx lens carriers)	12
9.13	Penetration	4
9.14	Prescription Lenses Material	3
9.15	Switching Index	1
9.16	Droplet and Splash	1
9.17	Dust	1
9.18	Fine Dust Particle	1

Annex B: Reference Headforms (normative)

NOTE: Permission to reproduce extracts from EN 168:2001 *Personal eye-protection. Non-optical test methods* is granted by BSI on behalf of CEN. Copyright subsists in all CEN Standards.

Headform Description

There are two sizes of reference head-form for the non-optical tests described in ANSI/ISEA Z87.1-2010.

The medium head-form approximates a 50th percentile adult male. The small head-form approximates a 60th percentile, 12 year old child.

The nominal dimensions are shown in Figure B1.

Where reference is made in this standard to a headform specified in this clause, the size of headform (medium or small) to be used shall be that which is appropriate to the eye protector being assessed.

Unless otherwise specified by the manufacturer of the eye protector, the medium size head-form shall be used.

All tests on the eye protector shall be performed using only the one size of headform selected.

The headform is an internal core covered by a nominal 12 mm thick layer of polyurethane of hardness (50 ± 5) IRHD .

Other headforms may be used if known or demonstrated to give equivalent results.

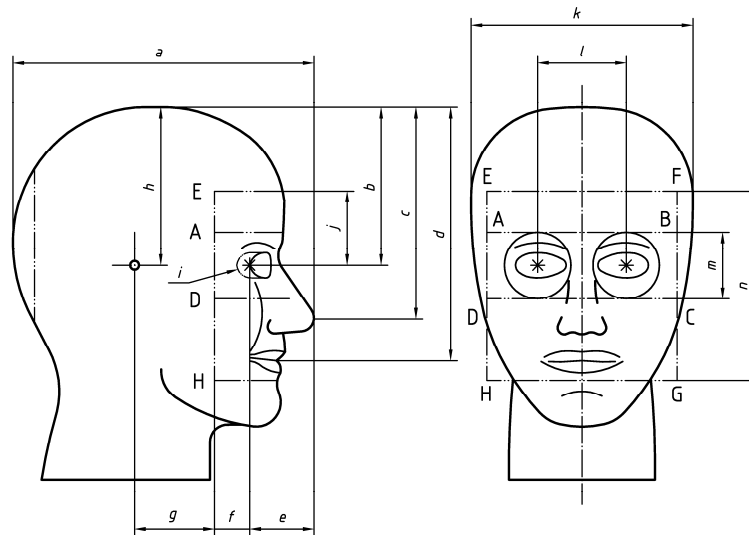

Figure B1 – Reference Head form

Dimension	Value	
	Medium size head	Small size head
a	218 mm (8.6 in.)	205 mm (8.1 in.)
b	111 mm (4.4 in.)	110 mm (4.3 in.)
c	144mm (5.7 in.)	131mm (5.2 in.)
d	178 mm (7.0 in.)	166mm (6.5 in.)
e	45 mm (1.8 in.)	42 mm (1.7 in.)
f	18 mm (0.7 in.)	18 mm (0.7 in.)
g	60 mm (2.4 in.)	53 mm (2.1 in.)
h	111 mm (4.4 in.)	110 mm (4.3 in.)
Radius i	10 mm (0.4 in.)	10 mm (0.4 in.)
j	58 mm (2.0 in.)	48 mm (1.9 in.)
k	156 mm (6.1 in.)	146 mm (5.7 in.)
l	64 mm (2.5 in.)	54 mm (2.1 in.)
m	52 mm (2.0 in.)	48 mm (1.9 in.)
n	134 mm (5.3 in.)	118 mm (4.6 in.)

Annex C: Spectral Factor Tables
(normative)

Table C1. Spectral Weighting Factors $W(\lambda)$ for Effective Far-Ultraviolet Average Transmittance

Wavelength (nm)	Spectral Weighting Factor $W(\lambda)$
200	0.03
210	0.075
220	0.12
230	0.19
240	0.30
250	0.43
254	0.5
260	0.65
270	1.0
280	0.88
290	0.64
300	0.30
305	0.06
310	0.015
315	0.003

NOTE: This table is a reproduction of Table 1 “Ultraviolet Radiation TLV and Relative Spectral Effectiveness,” from *Threshold Limit Values for Chemical Substances and Physical Agents & Biological Exposure Indices for 2008*. Published by the American Conference of Governmental Industrial Hygienists.

Table C2. Values of Relative Luminous Efficiency $\bar{y}(\lambda)$ for the CIE 1931 Standard colorimetric Observer and of Relative Spectral Emittance $S(\lambda)$ For CIE Illuminant A

$\lambda(\text{nm})$	$\bar{y}(\lambda)$	$S(\lambda)$	$\lambda(\text{nm})$	$\bar{y}(\lambda)$	$S(\lambda)$
380	0.0000	9.80	575	0.9154	110.80
385	0.0001	10.90	580	0.8700	114.44
390	0.0001	12.09	585	0.8163	118.08
395	0.0002	13.35	590	0.7570	121.73
			595	0.6949	125.39
400	0.0004	14.71			
405	0.0006	16.15	600	0.6310	129.04
410	0.0012	17.68	605	0.5668	132.70
415	0.0022	19.29	610	0.5030	136.35
420	0.0040	20.99	615	0.4412	139.99
			620	0.3810	143.62
425	0.0073	22.79			
430	0.0116	24.67	625	0.3210	147.24
435	0.0168	26.64	630	0.2650	150.84
440	0.0230	28.70	635	0.2170	154.42
445	0.0298	30.85	640	0.1750	157.98
			645	0.1382	161.52
450	0.0380	33.09			
455	0.0480	35.41	650	0.1070	165.03
460	0.0600	37.81	655	0.0816	168.51
465	0.0739	40.30	660	0.0610	171.96
470	0.0910	42.87	665	0.0446	175.38
			670	0.0320	178.77
475	0.1126	45.52			
480	0.1390	48.24	675	0.0232	182.12
485	0.1693	51.04	680	0.0170	185.43
490	0.2080	53.91	685	0.0119	188.70
495	0.2586	56.85	690	0.0082	191.93
			695	0.0057	195.12
500	0.3230	59.86			
505	0.4073	62.93	700	0.0041	198.26
510	0.5030	66.06	705	0.0029	201.36
515	0.6082	69.25	710	0.0021	204.41
520	0.7100	72.50	715	0.0015	207.41
			720	0.0010	210.36
525	0.7932	75.79			
530	0.8620	79.13	725	0.0007	213.27
535	0.9149	82.52	730	0.0005	216.12
540	0.9540	85.95	735	0.0004	218.92
545	0.9803	89.41	740	0.0002	221.67
			745	0.0002	224.36
550	0.9950	92.91			
555	1.0000	96.44	750	0.0001	227.00
560	0.9950	100.00	755	0.0001	229.59
565	0.9786	103.58	760	0.0001	232.12
570	0.9520	107.18	765	0	234.59
			770	0	237.01
			775	0	239.37
			780	0	241.68

**Table C3. Relative Spectral Emittance $S(\lambda)$ of CIE Illuminant A
for Wavelengths from 700 nm to 2600 nm**

λ	$S(\lambda)$	λ	$S(\lambda)$	λ	$S(\lambda)$	λ	$S(\lambda)$	λ	$S(\lambda)$	λ	$S(\lambda)$
700	198.26	1050	298.78	1400	232.72	1750	161.42	2100	108.81	2450	73.94
710	204.41	1060	289.28	1410	230.56	1760	159.63	2110	107.60	2460	73.15
720	210.36	1070	288.66	1420	228.40	1770	157.86	2120	106.40	2470	72.37
730	216.12	1080	287.94	1430	226.23	1780	156.10	2130	105.21	2480	71.60
740	221.67	1090	287.12	1440	224.06	1790	154.37	2140	104.04	2490	70.83
750	227.00	1100	286.20	1450	221.90	1800	152.65	2150	102.88	2500	70.08
760	232.12	1110	285.18	1460	219.74	1810	150.94	2160	101.73	2510	69.33
770	237.01	1120	284.08	1470	217.58	1820	149.25	2170	100.60	2520	68.60
780	241.68	1130	282.90	1480	215.42	1830	147.59	2180	99.48	2530	67.87
790	246.12	1140	281.64	1490	213.27	1840	145.93	2190	98.38	2540	67.15
800	250.83	1150	280.30	1500	211.13	1850	144.30	2200	97.29	2550	66.44
810	254.31	1160	278.89	1510	209.00	1860	142.68	2210	96.21	2560	65.74
820	258.07	1170	277.42	1520	206.87	1870	141.08	2220	95.14	2570	65.05
830	261.60	1180	275.89	1530	204.75	1880	139.50	2230	94.09	2580	64.37
840	264.91	1190	274.29	1540	202.64	1890	137.93	2240	93.05	2590	63.69
850	267.99	1200	272.64	1550	200.54	1900	136.38	2250	92.03	2600	63.02
860	270.86	1210	270.94	1560	198.45	1910	134.85	2260	91.01		
870	273.51	1220	269.20	1570	196.38	1920	133.33	2270	90.01		
880	275.95	1230	267.40	1580	194.31	1930	131.83	2280	89.02		
890	278.18	1240	265.57	1590	192.26	1940	130.35	2290	88.05		
900	280.21	1250	263.70	1600	190.22	1950	128.89	2300	87.08	Calculate by method given in Publication CIE No.15 (E-1.3.1) 1971 "COLORIMETRY," p. 23, par. (b)	
910	282.04	1260	261.79	1610	188.19	1960	127.44	2310	86.13		
920	283.68	1270	259.83	1620	186.18	1970	126.00	2320	85.19		
930	285.12	1280	257.88	1630	184.18	1980	124.59	2330	84.26		
940	286.39	1290	255.88	1640	182.20	1990	123.19	2340	83.34		
950	287.47	1300	253.86	1650	180.23	2000	121.80	2350	82.43	Values start at 700 nm to show overlap with values in Table C2 of this appendix.	
960	288.39	1310	251.81	1660	178.28	2010	120.43	2360	81.53		
970	289.14	1320	249.74	1670	176.34	2020	119.08	2370	80.65		
980	289.72	1330	247.66	1680	174.42	2030	117.74	2380	79.77		
990	290.15	1340	245.56	1690	172.51	2040	116.42	2390	78.91		
1000	290.43	1350	243.45	1700	170.62	2050	115.12	2400	78.06		
1010	290.57	1360	241.32	1710	168.75	2060	113.83	2410	77.21		
1020	290.57	1370	239.18	1720	166.89	2070	112.55	2420	76.38		
1030	290.43	1380	237.04	1730	165.05	2080	111.29	2430	75.56		
1040	290.17	1390	234.88	1740	163.23	2090	110.04	2440	74.75		

**Table C4. Spectral Weighting Factors
For Blue-Light Hazard**

Wavelength (nm)	Blue-Light hazard Factors B(λ)
400	.10
405	.20
410	.40
415	.80
420	.90
425	.95
430	.98
435	1.00
440	1.00
445	.97
450	.94
455	.90
460	.80
465	.70
470	.62
475	.55
480	.45
485	.40
490	.22
495	.16
500-600	$10 \exp [(450-\lambda)/50]$
600-700	.001

NOTE: This table is a reproduction of part of Table 1 “Retinal and UVR Hazard Spectral Weighting Functions”, from *Threshold Limit Values for Chemical Substances and Physical Agents & Biological Exposure Indices for 2008*. Published by the American Conference of Governmental Industrial Hygiene.

Annex D. Lateral (Side) Coverage Illustration (for Medium Headform)
(informative)

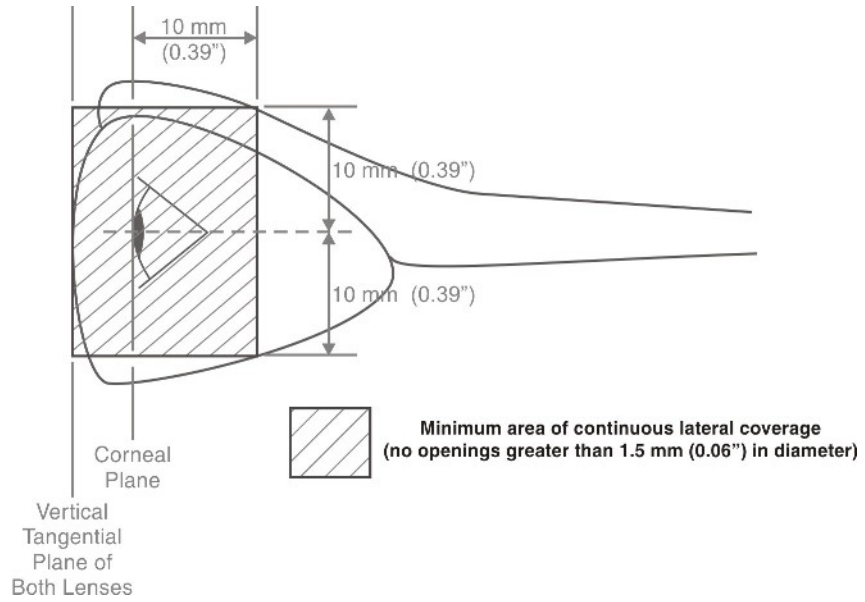

Annex E. Test Apparatus
(informative)

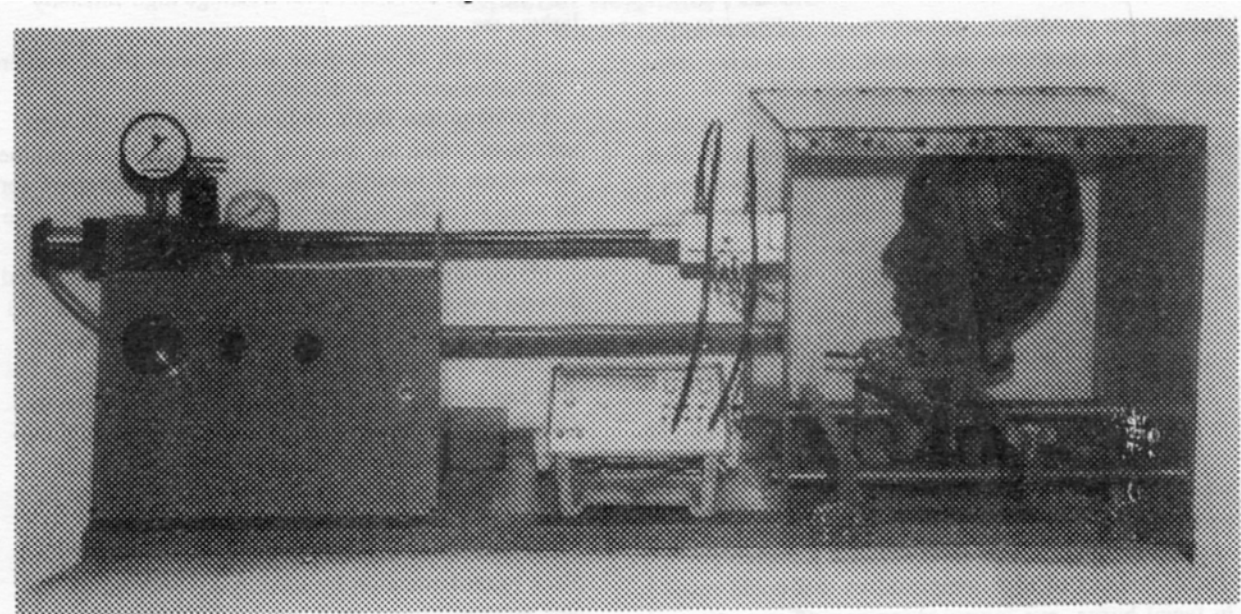

Figure E1 - High Velocity Impact Test Apparatus
The unit shown above or its equivalent is suitable for the high velocity impact test

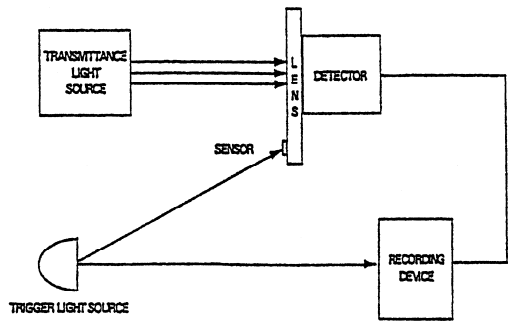

Figure E2
Switching Index Tightness Test Apparatus

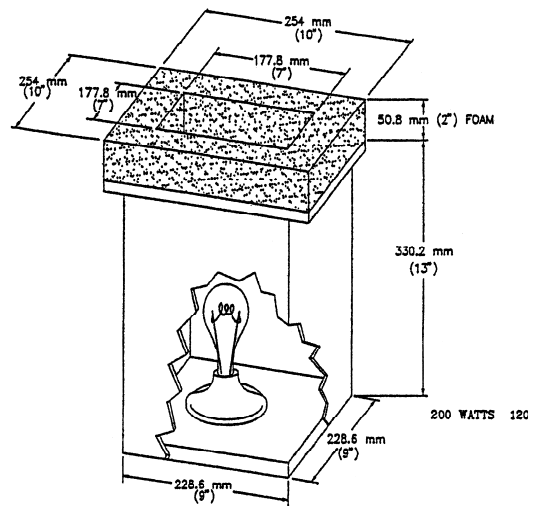

Figure E3
Typical Light Test Set Up Configuration

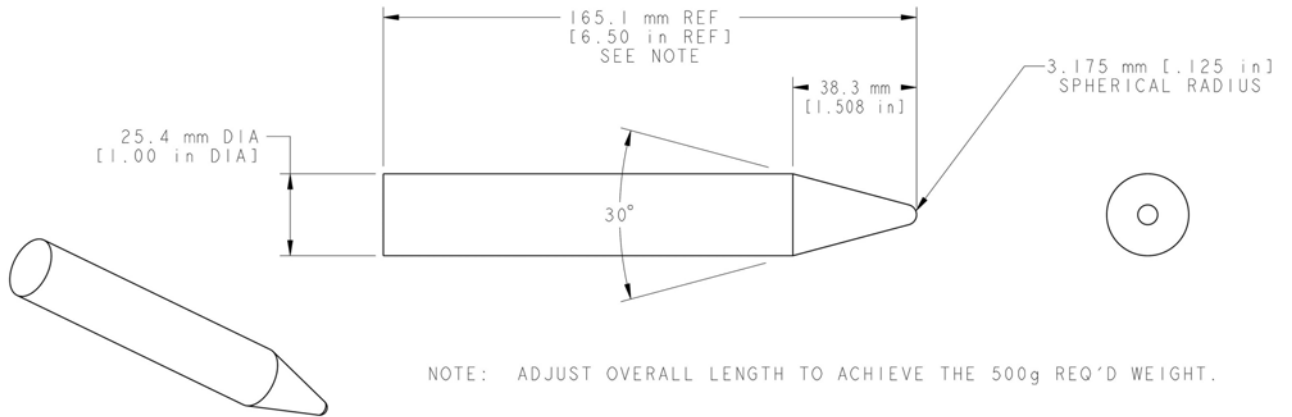

Figure E4
High Mass Impact Missile

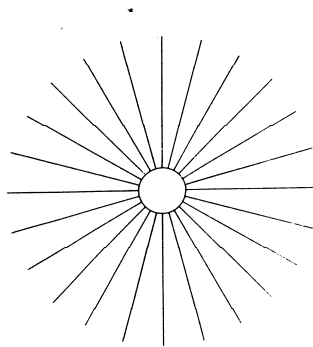

Figure E5
Test Pattern "Sunburst"

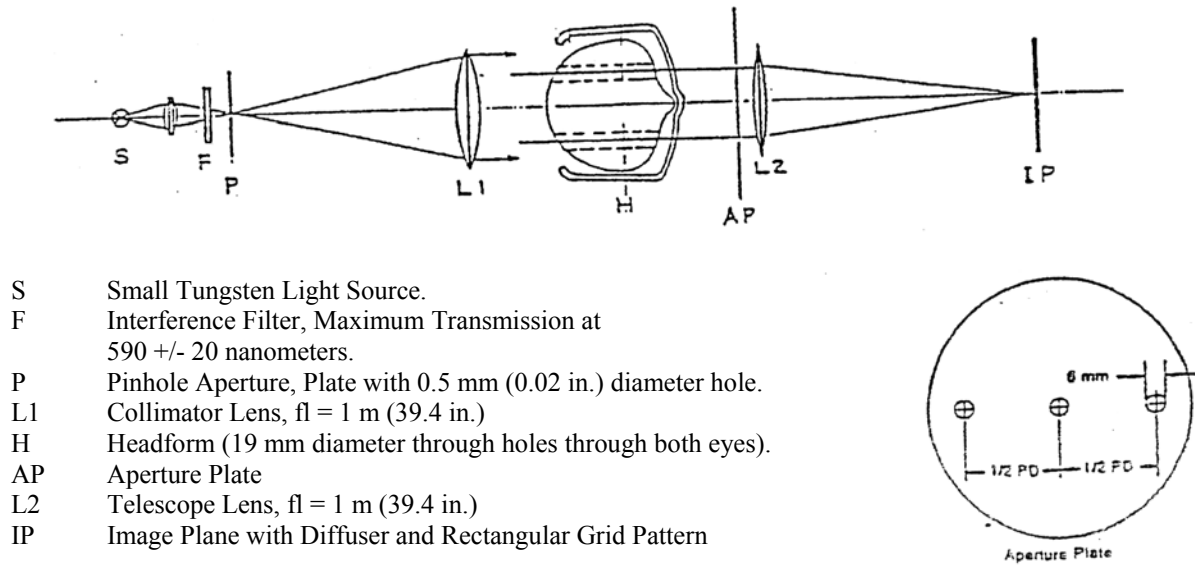

Figure E6 Prism Imbalance Test Apparatus

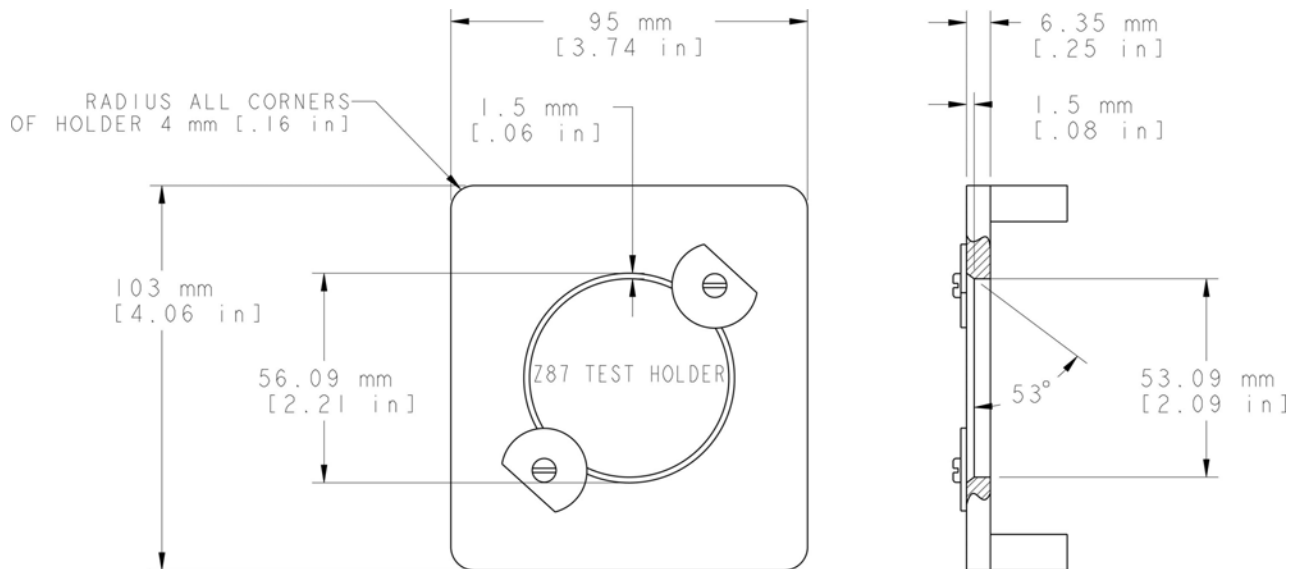
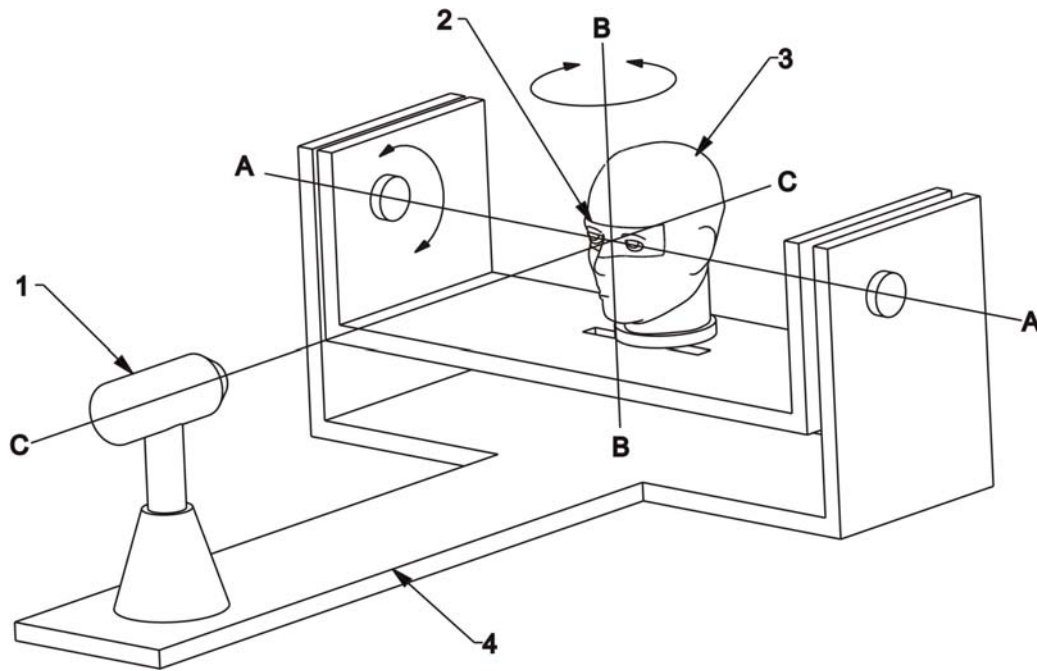

Figure E7 Prescription Lens Test Holder



Key

- 1 laser beam or cylindrical tube fitted with cross wires
- 2 rectangle enclosing the eye region
- 3 headform
- 4 support frame

Figure E8. Droplet and Splash Test Set Up for Faceshields

Annex F: Calibration of Test Telescope
(informative)

The telescope may be calibrated by any of the three methods given below.

(1) The telescope may be calibrated by successively locating the position of best focus with first a standard lens of +0.06 D in front of the objective and then with a standard lens of -0.06 D in front of the objective. The positions of the telescope drawtube or focusing knob, which correspond to the +/-0.06 D positions are marked on a suitable scale. The zero power position is located half the distance between the two marks. It should be verified that with no lens in front of the test telescope, the position of sharpest focus of the target is at the zero power scale position determined above. It is suggested that the scale distance between the +0.06 D position and -0.06 D position be divided into at least twenty equally spaced intervals so as to allow reasonably accurate determination of astigmatism.

(2) If effective focal length, f , of the telescope objective is measured or is known from data furnished with the telescope, then calibration of the power scale of the telescope may be done as follows:

Since P , the power of the telescope objective, is the reciprocal of the effective focal length of the objective in meters, if a lens of lower power, such as a plano lens, is placed near the telescope objective, the combined system will have a small change in focal length which causes re-focusing of the telescope to be necessary. Since $P = 1/f$, then $dP = -df/f$ and hence $df = -fdP$. Since the focal length of a typical test telescope is in the order of 200 mm (7.9 in.) (and hence it has a power of 5 Ds), the change in focal position produced by putting an acceptable plano lens in front of a telescope is small and hence the change in focal length (change of eyepiece position for best focus) is proportional to the power of the plano lens placed in front of the objective. Having calculated, then, the scale span between the +0.06 D and -0.06 D positions, the zero position must be determined. This is best done by having several operators take a number of readings at the best focus position for the 10.67 m (35 ft) distant target when no lens is in front of the telescope objective, and then averaging those readings. Before taking the readings, each operator should focus the eyepiece first on the cross hairs to suit his individual visual requirements.

(3) Vergence of light from a target at a distance of 10.67 m is $1/10.67 = -0.09372$ D, so the vergence required of the telescope is +0.09372 D to form an image of the target when no test lens is in place. If a lens of +0.06 D is placed in front of the telescope, vergence of light reaching the telescope is -0.09372 D + 0.06 D = -0.033721 D, which corresponds to light from a target at $1/0.033721$ D = 29.66 m (97.3 ft). Similarly, if a lens of -0.06 D is used, vergence of light reaching the telescope is -0.09372 D - 0.06 D = -0.153721 D, which corresponds to light from a target at 6.51 m (21.4 ft). Therefore, the positions of the telescope focusing knob corresponding to test lens powers of +/-0.06 D can be established by focusing the telescope at targets spaced 29.66 m (97.3 ft) and 6.51 m (21.4 ft) respectively from the telescope.

Annex G. Sources for Test Apparatus
(informative)

Source for All Test Apparatus, Headforms and Test Patterns:

ICS Laboratories
1072 Industrial Parkway North
Brunswick, OH 44212
(330)220-0515 FAX: (330)220-0516
www.icslabs.com

INSPEC International. Ltd.
56 Leslie Hough Way
Salford, Greater Manchester M6 6AJ
UNITED KINGDOM
44 (0) 16 1737 0699 FAX 44 (0) 16 1736 0101
www.inspec-international.com

Source for High Velocity and High Mass Impact Test Apparatus:

Skylark Machine
60 Veterans Drive, Unit 2
Holland, MI 49423
(616)396-7906 FAX: (616)396-7940
www.skylarkmachine.com

Source for Prismatic Power Test Apparatus:

Professional Services Industries, Inc.
Pittsburgh Testing Laboratory Division
850 Poplar Street
Pittsburgh, PA 15220
(412)922-4000 FAX(412)922-4014
www.psiusa.com

Annex H. Resource Publications
(informative)

ANSI Z49.1-2005, American National Standard Safety in Welding and Cutting

ANSI/ISEA Z89.1-2009, American National Standard for Industrial Head Protection

ANSI Z136.1-2007, American National Standard for Safe Use of Lasers

ASTM F803 – 03 Standard Specification for Eye Protectors for Selected Sports

29CFR1910.133 - Eye and Face Protection, OSHA General Industry Standards

29CFR1915.153 - Eye and Face Protection, OSHA Shipyard Standards

29CFR1926.102 - Eye and Face Protection, OSHA Construction Industry Standards

Annex I. Selection Chart (informative)

The Selection Chart is intended to aid in identifying and selecting the types of eye and face protectors that are available, their capabilities and limitations for the hazard source operations listed. This guide is not intended to be the sole reference in selecting the proper eye and face protector.

ANSI/ISEA Z87.1-2010

Eye and Face Protector Selection Chart

Protective devices do not provide unlimited protection. This information is intended to aid in identifying and selecting the types of eye and face protectors that are available, their capabilities and limitations for the hazards listed. This guide is not intended to be the sole reference in selecting the proper eye and face protector.

Hazard	Protectors	Limitations	Marking ¹
IMPACT - Chipping, grinding, machining, masonry work, riveting, and sanding Flying fragments, objects, large chips, particles, sand, dirt, etc.	<ul style="list-style-type: none"> • Spectacles with side protection • Goggles with direct or indirect ventilation • Faceshield worn over spectacles or goggles • Welding helmet 	<p>Caution should be exercised in the use of metal frame protective devices in electrical hazard areas. Metal frame protective devices could potentially cause electrical shock and electrical burn through contact with, or thermal burns from exposure to the hazards of electrical energy, which include radiation from accidental arcs.</p> <p>Atmospheric conditions and the restricted ventilation of a protector can cause lenses to fog. Frequent cleaning may be required.</p>	Impact rated: + (spectacle lens) Z87+ (all other lens) Z87+ (plano frame) Z87+2+ (Rx frame)
HEAT - Furnace operations - pouring, casting, hot tapping, gas cutting, and welding Hot sparks	<ul style="list-style-type: none"> • Spectacles with side protection • Goggles with direct or indirect ventilation • Faceshield worn over spectacles or goggles • Full-facepiece respirator¹ • Loose-fitting respirator worn over spectacles 	<p>Spectacles, cup and cover type goggles do not provide unlimited facial protection.</p> <p>Operations involving heat may also involve optical radiation. Protection from both hazards shall be provided.</p>	
Splash from molten metal	<ul style="list-style-type: none"> • Faceshield worn over goggles • Full-facepiece respirator • Loose-fitting respirator worn over spectacles 		
High temperature exposure	<ul style="list-style-type: none"> • Screen faceshield over spectacles or goggles • Reflective faceshield over spectacles or goggles 		
CHEMICAL - Acid and chemical handling, degreasing, plating			
Splash and irritating mists	<ul style="list-style-type: none"> • Goggles with indirect ventilation (eyecup or cover type) • Faceshield worn over spectacles or goggles • Full-facepiece respirator 	Atmospheric conditions and the restricted ventilation of a protector can cause lenses to fog. Frequent cleaning may be required.	Splash/droplet: D3
DUST - Woodworking, buffing, general dusty conditions Nuisance dust	<ul style="list-style-type: none"> • Goggles with direct or indirect ventilation (eyecup or cover type) • Full-facepiece respirator 	Atmospheric conditions and the restricted ventilation of a protector can cause lenses to fog. Frequent cleaning may be required.	Dust: D4 Fine dust: D5
OPTICAL RADIATION			
Welding: Electric Arc	<ul style="list-style-type: none"> • Welding helmet over spectacles or goggles • Hands/field over spectacles or goggles • TYPICAL FILTER LENS SHADE: 10-14 	Protection from optical radiation is directly related to filter lens density. Select the darkest shade that allows adequate task performance.	Welding: W shade number UV: U scale number Glare: L scale number IR: R scale number Variable tint: V Special purpose: S
Viewing electric arc furnaces and boilers	<ul style="list-style-type: none"> • Welding helmet over spectacles or goggles • Welding goggles • Welding faceshield over spectacles or goggles • TYPICAL FILTER LENS SHADE: 4-8 	Note: Filter lenses shall meet the requirements for shade designations in table 6 of ANSI/ISEA Z87.1-2010.	
Welding: Gas	<ul style="list-style-type: none"> • Welding helmet over spectacles or goggles • Welding goggles • Welding faceshield over spectacles or goggles • TYPICAL FILTER LENS SHADE: 4-8 		
Viewing gas-fired furnaces and boilers	<ul style="list-style-type: none"> • Welding goggles • Welding helmet over spectacles or goggles • Welding faceshield over spectacles or goggles • TYPICAL FILTER LENS SHADE: 3-6 		
Cutting	<ul style="list-style-type: none"> • Welding goggles • Welding helmet over spectacles or goggles • Welding faceshield over spectacles or goggles • TYPICAL FILTER LENS SHADE: 3-6 		
Torch brazing	<ul style="list-style-type: none"> • Welding goggles • Welding helmet over spectacles or goggles • Welding faceshield over spectacles or goggles • TYPICAL FILTER LENS SHADE: 3-4 		
Torch soldering	<ul style="list-style-type: none"> • Spectacles • Welding faceshield over spectacles • Welding respirator • TYPICAL FILTER LENS SHADE: 1.5-3 • Spectacles with or without side protection • Faceshield over spectacles or goggles 	Shade or special purpose lenses, as suitable. Note: Refer to definition of special purpose lenses in ANSI/ISEA Z87.1-2010.	
Glare			

1. Refer to ANSI/ISEA Z87.1-2010, table 4a for complete marking requirements.

Annex J. Hazard Assessment and Protector Selection (informative)

J.1 General

Protectors should be required where there is a reasonable probability of an eye or face injury that could be minimized or prevented by the use of such protection. In such cases, employers and educational authorities should make eye and face protectors conveniently available to employees and students for their use in the work environment, per applicable federal and state regulations. The employees and students should use such protectors. Where there is a reasonable probability of impact from flying objects, a protector with side protection should be required.

Known hazards should be removed or minimized to the extent possible. Protectors are not substitutes for engineering controls and sound safety practices. Protectors alone should not be relied upon to provide the sole means of protection against eye and face hazards. Protectors should be used in conjunction with engineering controls and sound safety practices.

Employers and employees should consult their federal, state and local safety and health regulatory authorities to become knowledgeable of the legal requirements applicable to their area. Under the Department of Labor, the Federal Occupational Safety and Health Administration (Fed OSHA) has codified in 29 Code of Federal Regulations (CFR) 1910 *Occupational Safety and Health Standards* and 29 CFR 1926 *Safety and Health Regulations for Construction* specific legal requirements and guidelines that employers must follow to protect their employees adequately (see specifically 29 CFR 1910.133 and 29 CFR 1926.102). By law, state and local government authorities can implement their own safety and health regulations if they are at least as protective as the federal regulations.

J.2 Hazard Assessment

The safety officer or other knowledgeable, responsible party should conduct an eye and face hazard assessment of the occupational or educational work setting. The hazard assessment should determine the risk of exposure to eye and face hazards, including those which may be encountered in an emergency. Employers should be aware of the possibility of multiple and simultaneous hazard exposures and be prepared to protect against the highest level of each hazard. Eye and face protectors alone should not be relied on to provide protection against any identified hazards, but should be used in conjunction with guards, engineering controls, and sound occupational and educational safety practices. At the minimum, the following hazard assessment procedure should be conducted to identify the existing and anticipated hazards and select appropriate eye and face protectors:

(1) Survey the Work Area. Conduct a walk-through survey of the area. The purpose of the survey is to identify sources of potential eye and face hazards. Consideration should be given to the six hazard categories addressed by this standard:

- (a) Impact
- (b) Heat
- (c) Chemical (Liquid Splash)
- (d) Dust
- (e) Glare
- (f) Optical Radiation

(2) Identify Sources of Hazards. During the walk-through survey observe:

- (a) Sources of motion; i.e., machinery or processes where any movement of tools, machine elements or particles could exist, or movement of personnel that could result in collision with sta-

tionary objects.

- (b) Sources of high temperatures that could result in facial burns, eye injury or ignition of protective equipment, etc.
- (c) Types of chemical exposures.
- (d) Sources of particles (i.e., dust, sparks, spray, mist).
- (e) Sources of optical radiation, i.e., welding, brazing, cutting, furnaces, heat treating, high intensity light sources and ultraviolet lamps.
- (f) Layout of workplace and location of other personnel.
- (g) Any electrical hazards.

(3) Organize Data. Following the walk-through survey, organize the data and information for use in the assessment of hazards. The objective is to prepare for an analysis of the hazards in the environment to enable proper selection of protective equipment.

(4) Analyze Data. Having gathered and organized data on a workplace, make an estimate of the potential for eye and face injury. Each of the basic hazards should be reviewed and a determination made as to the type and level of each of the hazards found in the area. The possibility of exposure to several hazards simultaneously should be considered.

(5) Selection. Specify the protector(s) suitable for the hazards identified (see Annex I, Selection Chart).

(6) Reassessment of Hazards. A periodic reassessment of the work area should be performed on a regular basis to identify changes in the hazard situation that could affect the level of protection required. Reassess the workplace hazard situation by identifying and evaluating new equipment and processes, reviewing incident records, and reassessing the suitability of previously selected eye and face protection.

J.3 Protector Selection

After completing a thorough hazard assessment of the environment such as recommended in Annex J.2, the general procedure for selection of protective equipment is as follows:

- (1) Become familiar with the Selection Chart (Annex I), the types of protective equipment that are available, their capabilities and limitations.
- (2) Compare the hazards associated with the environment, i.e., impact velocities, masses, projectile shape, radiation intensities, etc., with the available protective equipment.
- (3) Make a judgment in selection of the appropriate protective equipment so that the protection is consistent with the reasonably probable hazard.
- (4) Protectors not specifically rated for impact or protectors complying only with the applicable requirements of Section 5 may be used only in an environment where the known or presumed impact, radiation and dust, mist and splash hazards do not exist or are of minimal intensity or probability of occurrence. Impact-rated protectors should be used in an environment when the known or presumed hazards are of a high velocity, high mass or high impact nature.
- (5) Provide and fit the user with the protector and provide instruction on its care, use and limitations as recommended in Annexes J.4 and J.6.

(Note: Be aware that spectacles, goggles, and face shields are tested with different impact criteria so the protector selection should be consistent to the testing.)

The Selection Chart is intended to aid in identifying and selecting the types of eye and face protectors that are available. The capabilities and limitations for the hazard are listed in this guide. This guide is not intended to be the sole reference in selecting the proper eye and face protector.

J.4 Product Use and Limitations

Protectors are a personal item. They should be issued for exclusive use by a particular individual. However, in circumstances where protectors are reissued, the protectors should be maintained in a sanitary and reliable condition.

Caution should be exercised to ensure that the level of protection provided by any protector is adequate for its intended purpose.

See the Selection Chart for information on specific applications.

Additional information regarding training can be found in the American National Standard, Z490.1-2001, *Criteria for Accepted Practices in Safety, Health, and Environmental Training*.

J.5 Special Purpose Protectors and Lenses

Special purpose protectors and lenses are those which meet the requirements of Table 10, but do not meet the requirements of Table 6, Table 7, Table 8 or Table 9. They are designed for specific applications. They might not provide adequate ultraviolet protection, infrared protection, or ultraviolet and infrared protection when used for applications for which they are not designed. Therefore, special purpose protectors and lenses should be used only after a complete hazard assessment and at the discretion of the individual responsible for the selection of protectors.

J.6 Prescription (Rx) Eyewear

Wearers of prescription (Rx) eyewear should wear eye protection that incorporates the prescription in its design or that can be worn over prescription lenses without disrupting either the prescription eyewear or the protective eyewear.

Contact lens wearers should recognize that dusty and/or chemical environments may represent an additional hazard. Contact lenses are not protectors. If contact lens wear is authorized and medically approved for the use in a hazardous environment, they should only be worn in conjunction with appropriate eye protectors.

J.7 Filter Lenses and Windows

A filter lens meets the ultraviolet, luminous and infrared transmittance requirements of Table 6, Table 7, Table 8 or Table 9 and is permanently marked with a shade/scale number that indicates its transmittance levels in accordance with Table 7, Table 8 or Table 9. Filter lenses of an appropriate shade are suitable for protection from direct exposure to optical radiation from sources of very high radiance, such as welding arcs. Filter lenses are also suitable for protection from sources of low radiance, provided that they are not so dark as to interfere with normal visual performance of the task.

J.8 Tinted Lenses and Windows

Lenses having low luminous transmittance should not be worn indoors, except when needed for protection from optical radiation. Care should be exercised in conjunction with wearing such lenses for driving vehicles with tinted windshields or for night driving. Some polarized lenses may present viewing prob-

lenses when reading liquid crystal displays. Some tinted lenses may absorb certain wavelengths of visual displays or signs, rendering them unreadable.

J.9 Photochromic Lenses

Photochromic lenses darken when exposed to, and fade when removed from, ultraviolet radiation or sunlight. They are frequently used to provide comfortable vision for a wide range of ambient illumination. They should be used with care where the wearer passes from outdoors to indoors in the course of the job. Photochromic lenses that do not meet the transmittance requirements of Table 6 and the switching index requirements of Table 11 are not suitable for protection from direct exposure to high radiance sources (e.g., welding arcs and unshielded high intensity lamps). Photochromic lenses that do not meet the switching index requirements in Table 11 are not automatic darkening welding filters. Photochromic lenses should be used only after a complete hazard assessment and at the discretion of the person responsible for the selection of protectors.

J.10 Protection from Low Radiance Sources of Ultraviolet and Visible Radiation

Some lenses that comply with the transmittance requirements of Table 7, but not with all of the requirements of Table 6, can provide sufficient ultraviolet attenuation to be used for protection from direct exposure to ultraviolet sources of low radiance and from indirect exposure (i.e., scattered radiation) to properly shielded ultraviolet sources of high radiance. Lenses that have some attenuation of visible light may also be suitable for protection from scattered light from properly shielded high radiance sources of visible light.

J.11 Fitting the Protector

Careful consideration should be given to comfort and fit. Protectors that fit poorly will not afford the protection for which they were designed. Protectors should be fitted by qualified personnel. Continued wearing of protectors is more likely when they fit the wearer comfortably. Protectors are generally available in a variety of styles and sizes and care should be taken to ensure that the right size is selected for a particular person. For protectors with adjustable fitting features, adjustments should be made on a regular and individual basis for a comfortable fit, which will maintain the protector in its proper wearing position.

Some protectors may not be compatible with other personal protective equipment when worn together, such as goggles with faceshields, goggles with respirators and spectacles with goggles. The end user should carefully match protectors with other personal protective equipment to provide the protection intended.

Because of individual facial characteristics, care must be exercised in fitting goggles to ensure that a snug fit around the face is achieved in order to provide adequate protection.