

TAG: \_\_\_\_\_

## SUBMITTAL

### 1.5 Ton Multi-position Air Handler M4AH4P18B1A00AA

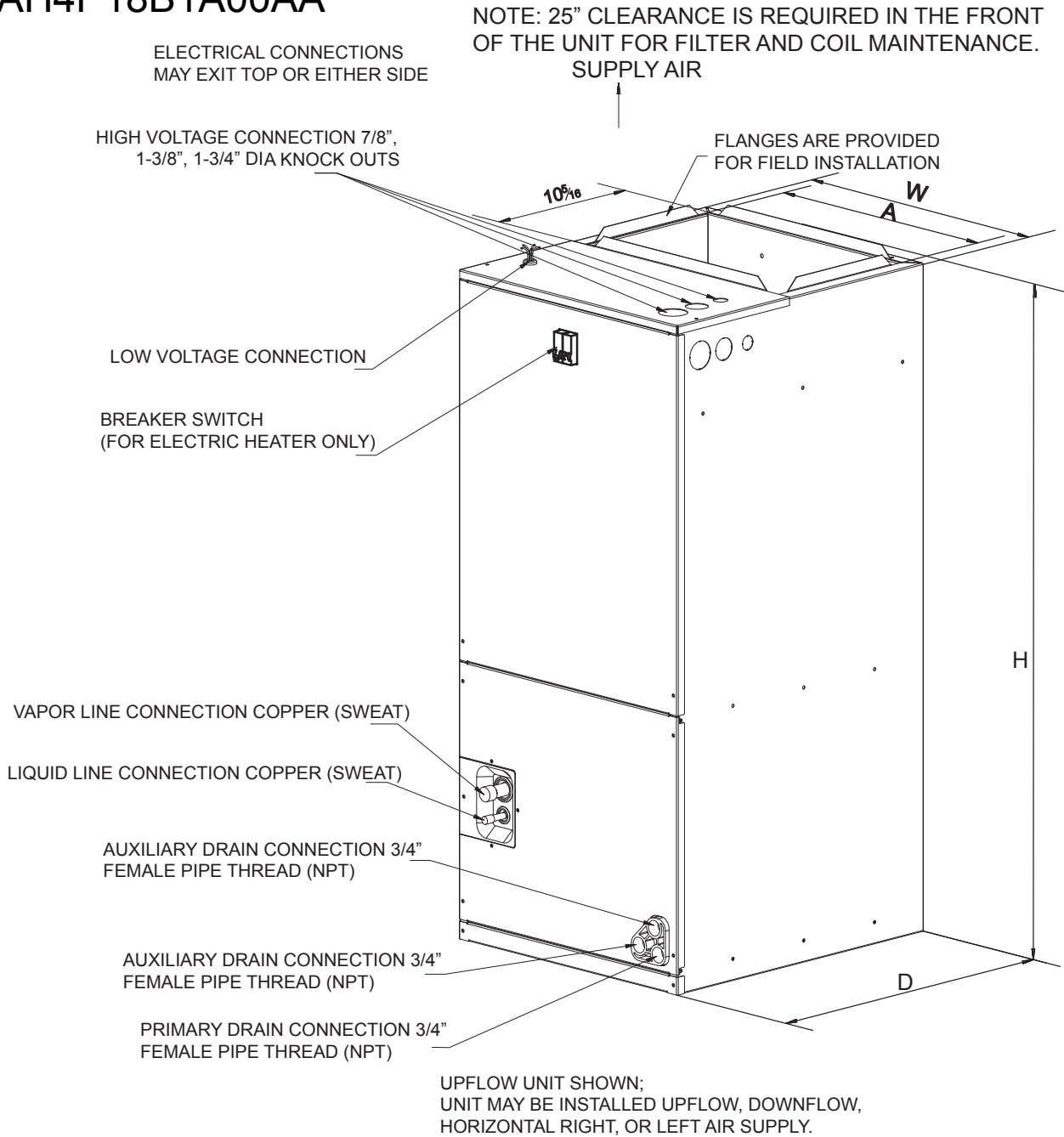

NOTE: All dimensions are in mm/inches.

Model	H	W	D	A
M4AH4P18B1A00AA	1050 (41-3/8)	460 (18-1/8)	520 (20-1/2)	406 (16)

# PRODUCT SPECIFICATIONS

## PRODUCT SPECIFICATIONS

MODEL	M4AH4P18B1A00AA
RATED VOLTS/PH/HZ.	208-230/1/60
RATINGS	See O.D. Specifications
INDOOR COIL — Type	Plate Fin
Rows — F.P.I.	4 - 17
Face Area (sq. ft.)	2.99
Tube Size (in.)	9/32
Refrigerant Control	Orifice
Drain Conn. Size (in.)	3/4 NPT
DUCT CONNECTIONS	See Outline Drawing
INDOOR FAN — Type	Centrifugal
Diameter-Width (In.)	10-5/8 X 8-1/8
No. Used	1
Drive - No. Speeds	Direct - 3
CFM vs. in. w.g.	See Fan Performance Table
No. Motors — H.P.	1 - 1/8
Motor Speed R.P.M.	1075
Volts/Ph/Hz	208-230/1/60
F.L. Amps	1.4
FILTER	
Filter Furnished?	No
Type Recommended	Throwaway
No.-Size-Thickness	1 - 16 X 20 - 1 in.
REFRIGERANT	R-410A
Ref. Line Connections	Brazed
Coupling or Conn. Size — in. Gas	3/4
Coupling or Conn. Size — in. Liq.	3/8
DIMENSIONS	H x W x D
Crated (In.)	42-7/10 x 21 x 24-1/6
Uncrated	41-3/8 x 18-1/8 x 20-1/2
WEIGHT	
Shipping (Lbs.)/Net (Lbs.)	117/104



**Intertek**



Heater Kit Model Used	Electric Heat (kW)	Min. Circuit Ampacity		Max. Fuse or Breaker (HACR) Ampacity		Minimum Heating Blower Speed	
		240V	208V	240V	208V	Without HP	With HP
MAYHTR1A05BKR*	5	27.9	24.4	30	25	Low	Low
MAYHTR1A08BKR*	7.5	40.9	35.7	45	40	Low	Low
MAYHTR1A10BKR*	10	53.9	47	60	50	Low	Low

Note: Factory set at Medium Speed.

Motor Speed	AIR FLOW PERFORMANCE									
	M4AH4P18B1A00AA									
	External Static Pressure-Inches W.C. (kPa)									
		0(0)	0.1(.02)	0.2(.05)	0.3(.07)	0.4(.10)	0.5(.12)	0.6(.15)	0.7(.17)	0.8(.20)
Low	CFM	563	498	434	373	317	246	217	-	-
Medium	CFM	695	633	576	509	457	388	318	240	231
High	CFM	927	872	815	761	697	633	566	510	380

# Mechanical Specifications

---

- Unique Cabinet Design
- Metal shell and glass cotton thermal insulation layer
- Multi-Position UP/Down Flow Horizontal Left /Right
- Braze in Refrigerant Connection
- Primary/Secondary Condensate Connections
- Blower with Integrated Slide Deck for Easy Removal
- Inner-groove aluminum tube and high-efficiency aluminum fin Coil with Integrated Slide Deck for Easy Removal
- More auxiliary Electric Heaters optional
- PSC 3 Speed Motor
- High Efficiency
- Integrated Horizontal Drain pans and metal Vertical Drain
- Fused 24V Power
- 5-Year Warranty.
- 10-Year Warranty Registered.
- Warranty Mirrors Outdoor.
- Optional extended warranty available.

Ameristar



The manufacturer has a policy of continuous product and product data improvement and it reserves the right to change design and specification without notice.

TAG: \_\_\_\_\_

## SUBMITTAL

### 2.0 Ton Multi-position Air Handler M4AH4P25B1B00AA

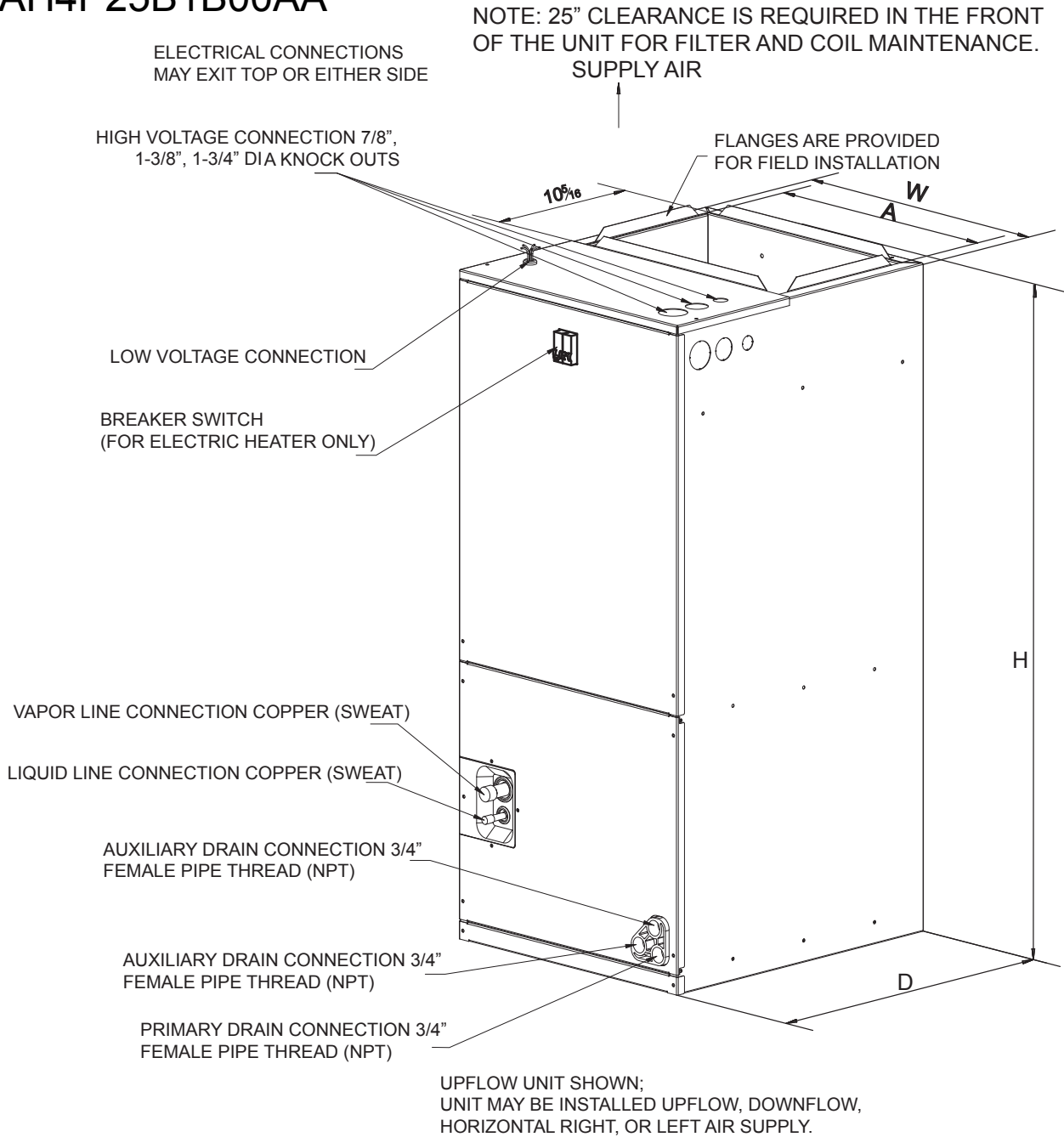

NOTE: All dimensions are in mm/inches.

Model	H	W	D	A
M4AH4P25B1B00AA	1180 (46-1/2)	500 (19-5/8)	550 (21-5/8)	456 (18)

## PRODUCT SPECIFICATIONS

### PRODUCT SPECIFICATIONS

MODEL	M4AH4P25B1B00AA
RATED VOLTS/PH/HZ.	208-230/1/60
RATINGS	See O.D. Specifications
INDOOR COIL — Type	Plate Fin
Rows — F.P.I.	4 - 17
Face Area (sq. ft.)	4.01
Tube Size (in.)	9/32
Refrigerant Control	Orifice
Drain Conn. Size (in.)	3/4 NPT
DUCT CONNECTIONS	See Outline Drawing
INDOOR FAN — Type	Centrifugal
Diameter-Width (In.)	10-5/8 X 10-3/4
No. Used	1
Drive - No. Speeds	Direct - 3
CFM vs. in. w.g.	See Fan Performance Table
No. Motors — H.P.	1 - 1/5
Motor Speed R.P.M.	1075
Volts/Ph/Hz	208-230/1/60
F.L. Amps	1.6
FILTER	
Filter Furnished?	No
Type Recommended	Throwaway
No.-Size-Thickness	1 - 18X 20 - 1 in.
REFRIGERANT	R-410A
Ref. Line Connections	Brazed
Coupling or Conn. Size — in. Gas	3/4
Coupling or Conn. Size — in. Liq.	3/8
DIMENSIONS	H x W x D
Crated (In.)	47-4/5 x 22-3/5 x 25-7/10
Uncrated	46-1/2 x 19-5/8 x 21-5/8
WEIGHT	
Shipping (Lbs.)/Net (Lbs.)	141/125



**Intertek**



Heater Kit Model Used	Electric Heat (kW)	Min. Circuit Ampacity		Max. Fuse or Breaker (HACR) Ampacity		Minimum Heating Blower Speed	
		240V	208V	240V	208V	Without HP	With HP
MAYHTR1A05BKR*	5	28.1	24.6	30	25	Low	Low
MAYHTR1A08BKR*	7.5	41.1	35.9	45	40	Low	Low
MAYHTR1A10BKR*	10	54.1	47.2	60	50	Low	Low

Note: Factory set at Medium Speed.

Motor Speed		AIR FLOW PERFORMANCE								
		M4AH4P25B1B00AA								
		External Static Pressure-Inches W.C. (kPa)								
		0(0)	0.1(.02)	0.2(.05)	0.3(.07)	0.4(.10)	0.5(.12)	0.6(.15)	0.7(.17)	0.8(.20)
Low	CFM	743	692	619	550	494	409	339	245	190
Medium	CFM	958	913	865	810	711	656	576	467	368
High	CFM	1107	1066	1022	973	897	807	697	662	526

# Mechanical Specifications

---

- Unique Cabinet Design
- Metal shell and glass cotton thermal insulation layer
- Multi-Position UP/Down Flow Horizontal Left /Right
- Braze in Refrigerant Connection
- Primary/Secondary Condensate Connections
- Blower with Integrated Slide Deck for Easy Removal
- Inner-groove aluminum tube and high-efficiency aluminum fin Coil with Integrated Slide Deck for Easy Removal
- More auxiliary Electric Heaters optional
- PSC 3 Speed Motor
- High Efficiency
- Integrated Horizontal Drain pans and metal Vertical Drain
- Fused 24V Power
- 5-Year Warranty.
- 10-Year Warranty Registered.
- Warranty Mirrors Outdoor.
- Optional extended warranty available.

Ameristar



The manufacturer has a policy of continuous product and product data improvement and it reserves the right to change design and specification without notice.

TAG: \_\_\_\_\_

## SUBMITTAL

### 2.5 Ton Multi-position Air Handler M4AH4P32B1B00AA

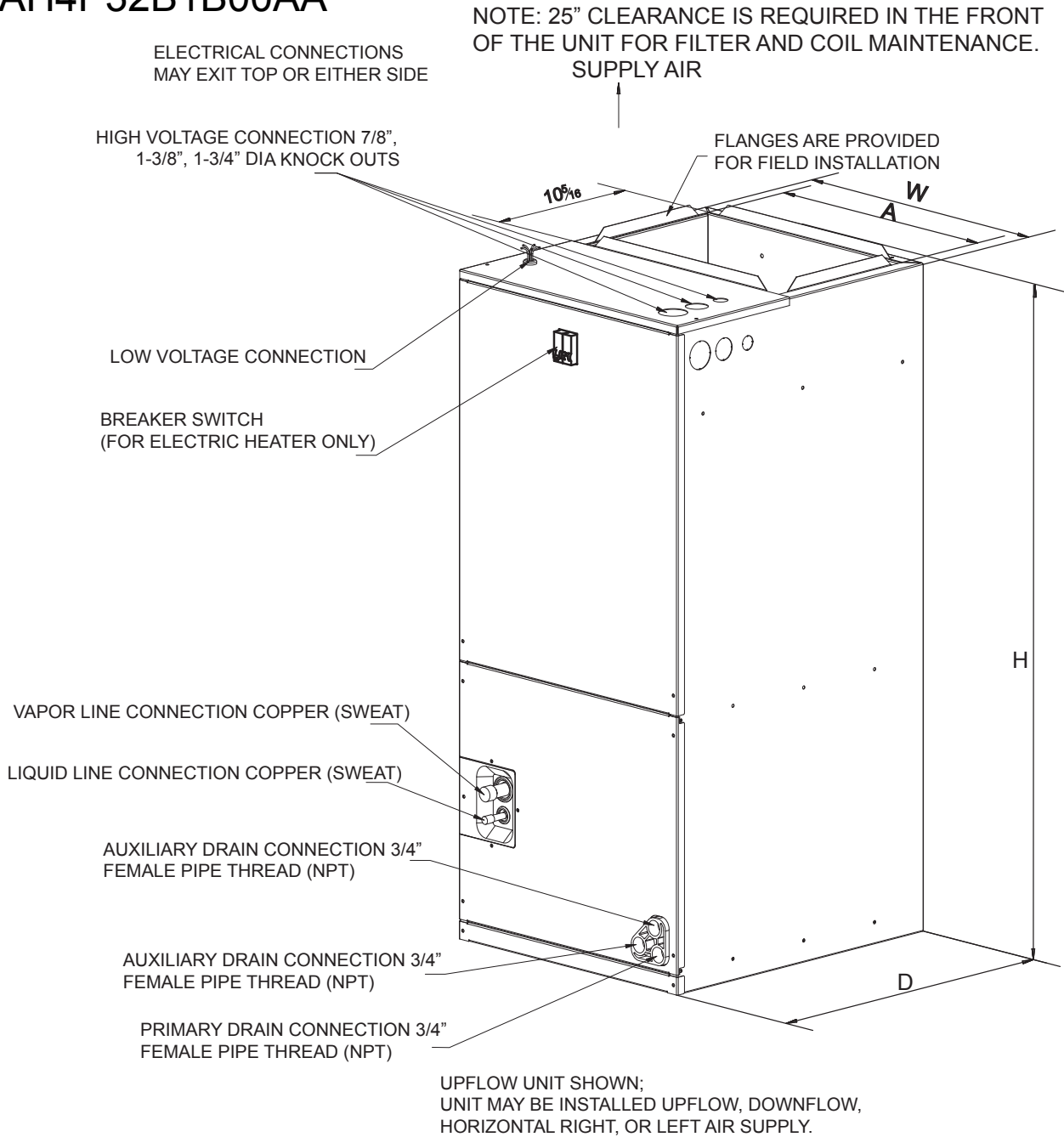

NOTE: All dimensions are in mm/inches.

Model	H	W	D	A
M4AH4P32B1B00AA	1180 (46-1/2)	500 (19-5/8)	550 (21-5/8)	456 (18)

## PRODUCT SPECIFICATIONS

### PRODUCT SPECIFICATIONS

MODEL	M4AH4P32B1B00AA
RATED VOLTS/PH/HZ.	208-230/1/60
RATINGS	See O.D. Specifications
INDOOR COIL — Type	Plate Fin
Rows — F.P.I.	4 - 17
Face Area (sq. ft.)	4.01
Tube Size (in.)	9/32
Refrigerant Control	Orifice
Drain Conn. Size (in.)	3/4 NPT
DUCT CONNECTIONS	See Outline Drawing
INDOOR FAN — Type	Centrifugal
Diameter-Width (In.)	10-5/8 X 10-3/4
No. Used	1
Drive - No. Speeds	Direct - 3
CFM vs. in. w.g.	See Fan Performance Table
No. Motors — H.P.	1 - 1/4
Motor Speed R.P.M.	1075
Volts/Ph/Hz	208-230/1/60
F.L. Amps	2.3
FILTER	
Filter Furnished?	No
Type Recommended	Throwaway
No.-Size-Thickness	1 - 18X 20 - 1 in.
REFRIGERANT	R-410A
Ref. Line Connections	Brazed
Coupling or Conn. Size — in. Gas	3/4
Coupling or Conn. Size — in. Liq.	3/8
DIMENSIONS	H x W x D
Crated (In.)	47-4/5 x 22-3/5 x 25-7/10
Uncrated	46-1/2 x 19-5/8 x 21-5/8
WEIGHT	
Shipping (Lbs.)/Net (Lbs.)	143/128



**Intertek**



Heater Kit Model Used	Electric Heat (kW)	Min. Circuit Ampacity		Max. Fuse or Breaker (HACR) Ampacity		Minimum Heating Blower Speed	
		240V	208V	240V	208V	Without HP	With HP
MAYHTR1A05BKR*	5	29	25.5	35	30	Low	Low
MAYHTR1A08BKR*	7.5	42	36.8	45	40	Low	Low
MAYHTR1A10BKR*	10	55	48.1	60	50	Low	Low
MAYHTR1A15BKR*	15	55/26.1	48.1/22.6	60/30	50/25	Low	Low

Note: Factory set at Medium Speed.

Motor Speed	AIR FLOW PERFORMANCE									
	M4AH4P32B1B00AA									
	External Static Pressure-Inches W.C. (kPa)									
		0(.0)	0.1(.02)	0.2(.05)	0.3(.07)	0.4(.10)	0.5(.12)	0.6(.15)	0.7(.17)	0.8(.20)
Low	CFM	999	953	905	847	757	681	610	543	411
Medium	CFM	1176	1127	1086	1028	944	842	746	668	569
High	CFM	1409	1359	1306	1253	1192	1108	986	870	743



# Mechanical Specifications

---

- Unique Cabinet Design
- Metal shell and glass cotton thermal insulation layer
- Multi-Position UP/Down Flow Horizontal Left /Right
- Braze in Refrigerant Connection
- Primary/Secondary Condensate Connections
- Blower with Integrated Slide Deck for Easy Removal
- Inner-groove aluminum tube and high-efficiency aluminum fin Coil with Integrated Slide Deck for Easy Removal
- More auxiliary Electric Heaters optional
- PSC 3 Speed Motor
- High Efficiency
- Integrated Horizontal Drain pans and metal Vertical Drain
- Fused 24V Power
- 5-Year Warranty.
- 10-Year Warranty Registered.
- Warranty Mirrors Outdoor.
- Optional extended warranty available.

Ameristar



The manufacturer has a policy of continuous product and product data improvement and it reserves the right to change design and specification without notice.

TAG: \_\_\_\_\_

## SUBMITTAL

### 3.0 Ton Multi-position Air Handler M4AH4P36B1B00AA

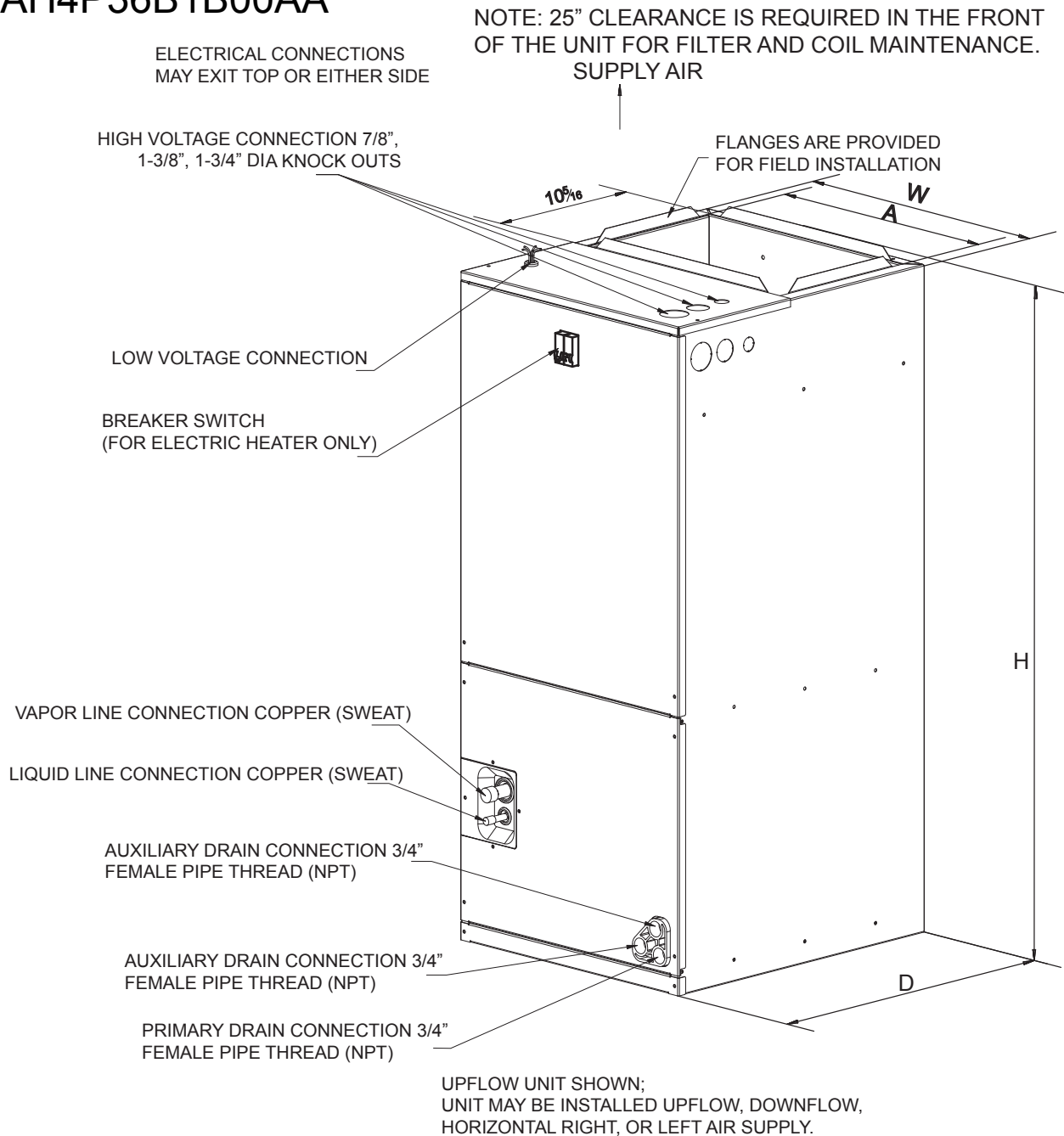

NOTE: All dimensions are in mm/inches.

Model	H	W	D	A
M4AH4P36B1B00AA	1180 (46-1/2)	500 (19-5/8)	550 (21-5/8)	456 (18)

# PRODUCT SPECIFICATIONS

## PRODUCT SPECIFICATIONS

MODEL	M4AH4P36B1B00AA
RATED VOLTS/PH/HZ.	208-230/1/60
RATINGS	See O.D. Specifications
INDOOR COIL — Type	Plate Fin
Rows — F.P.I.	4 - 17
Face Area (sq. ft.)	4.01
Tube Size (in.)	9/32
Refrigerant Control	Orifice
Drain Conn. Size (in.)	3/4 NPT
DUCT CONNECTIONS	See Outline Drawing
INDOOR FAN — Type	Centrifugal
Diameter-Width (In.)	10-5/8 X 10-3/4
No. Used	1
Drive - No. Speeds	Direct - 3
CFM vs. in. w.g.	See Fan Performance Table
No. Motors — H.P.	1 - 1/2
Motor Speed R.P.M.	1075
Volts/Ph/Hz	208-230/1/60
F.L. Amps	2.6
FILTER	
Filter Furnished?	No
Type Recommended	Throwaway
No.-Size-Thickness	1 - 18X 20 - 1 in.
REFRIGERANT	R-410A
Ref. Line Connections	Brazed
Coupling or Conn. Size — in. Gas	3/4
Coupling or Conn. Size — in. Liq.	3/8
DIMENSIONS	H x W x D
Crated (In.)	47-4/5 x 22-3/5 x 25-7/10
Uncrated	46-1/2 x 19-5/8 x 21-5/8
WEIGHT	
Shipping (Lbs.)/Net (Lbs.)	143/128



**Intertek**



Heater Kit Model Used	Electric Heat (kW)	Min. Circuit Ampacity		Max. Fuse or Breaker (HACR) Ampacity		Minimum Heating Blower Speed	
		240V	208V	240V	208V	Without HP	With HP
MAYHTR1A05BKR*	5	29.4	25.9	35	30	Low	Low
MAYHTR1A08BKR*	7.5	42.4	37.2	45	40	Low	Low
MAYHTR1A10BKR*	10	55.4	48.5	60	50	Low	Low
MAYHTR1A15BKR*	15	55.4/26.1	48.5/22.6	60/30	50/25	Low	Low
MAYHTR1A20BKR*	20	55.4/52.1	48.5/45.2	60/60	50/50	Low	Low

Note: Factory set at Medium Speed.

Motor Speed	AIR FLOW PERFORMANCE									
	M4AH4P36B1B00AA									
	External Static Pressure-Inches W.C. (kPa)									
		0(0)	0.1(.02)	0.2(.05)	0.3(.07)	0.4(.10)	0.5(.12)	0.6(.15)	0.7(.17)	0.8(.20)
Low	CFM	1028	985	930	859	781	712	649	571	468
Medium	CFM	1315	1266	1208	1146	1065	981	866	775	686
High	CFM	1532	1478	1421	1347	1284	1184	1082	932	805

# Mechanical Specifications

---

- Unique Cabinet Design
- Metal shell and glass cotton thermal insulation layer
- Multi-Position UP/Down Flow Horizontal Left /Right
- Braze in Refrigerant Connection
- Primary/Secondary Condensate Connections
- Blower with Integrated Slide Deck for Easy Removal
- Inner-groove aluminum tube and high-efficiency aluminum fin Coil with Integrated Slide Deck for Easy Removal
- More auxiliary Electric Heaters optional
- PSC 3 Speed Motor
- High Efficiency
- Integrated Horizontal Drain pans and metal Vertical Drain
- Fused 24V Power
- 5-Year Warranty.
- 10-Year Warranty Registered.
- Warranty Mirrors Outdoor.
- Optional extended warranty available.

Ameristar



The manufacturer has a policy of continuous product and product data improvement and it reserves the right to change design and specification without notice.

TAG: \_\_\_\_\_

## SUBMITTAL

### 3.5 Ton Multi-position Air Handler M4AH4P44B1C00AA

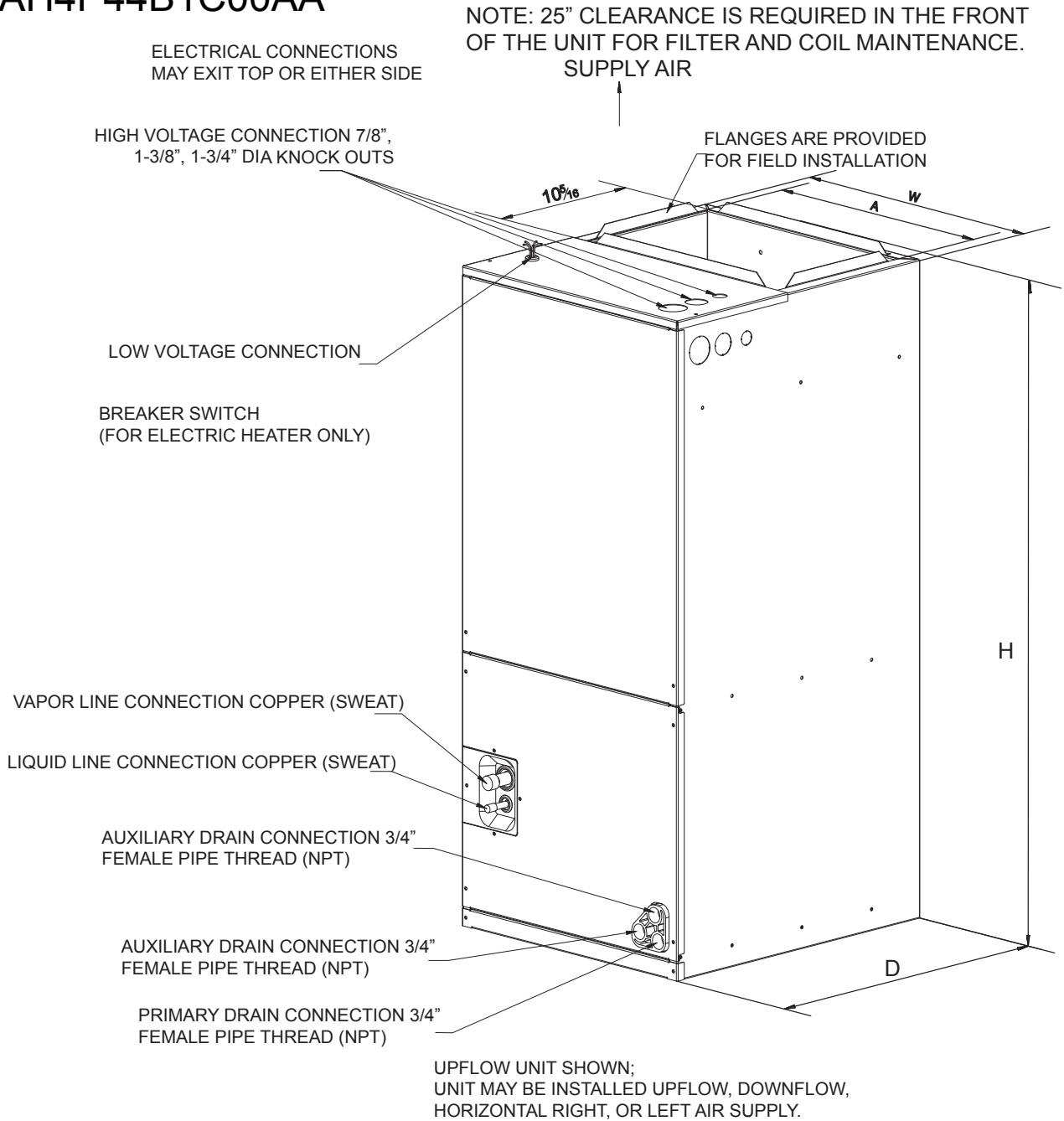

NOTE: All dimensions are in mm/inches.

Model	H	W	D	A
M4AH4P44B1C00AA	1385 (54-1/42)	560 (22)	610 (24)	496 (19-1/2)

# PRODUCT SPECIFICATIONS

## PRODUCT SPECIFICATIONS

MODEL	M4AH4P44B1C00AA
RATED VOLTS/PH/HZ.	208-230/1/60
RATINGS	See O.D. Specifications
INDOOR COIL — Type	Plate Fin
Rows — F.P.I.	4 - 17
Face Area (sq. ft.)	6.00
Tube Size (in.)	9/32
Refrigerant Control	Orifice
Drain Conn. Size (in.)	3/4 NPT
DUCT CONNECTIONS	See Outline Drawing
INDOOR FAN — Type	Centrifugal
Diameter-Width (In.)	10-5/8 X 10-3/4
No. Used	1
Drive - No. Speeds	Direct - 3
CFM vs. in. w.g.	See Fan Performance Table
No. Motors — H.P.	1 - 1/2
Motor Speed R.P.M.	1075
Volts/Ph/Hz	208-230/1/60
F.L. Amps	2.6
FILTER	
Filter Furnished?	No
Type Recommended	Throwaway
No.-Size-Thickness	1 - 20 X 22 - 1 in.
REFRIGERANT	R-410A
Ref. Line Connections	Brazed
Coupling or Conn. Size — in. Gas	7/8
Coupling or Conn. Size — in. Liq.	3/8
DIMENSIONS	H x W x D
Crated (In.)	55-4/5 x 25 x 27-7/10
Uncrated	54-1/2 x 22 x 24
WEIGHT	
Shipping (Lbs.)/Net (Lbs.)	177/159



**Intertek**



Heater Kit Model Used	Electric Heat (kW)	Min. Circuit Ampacity		Max. Fuse or Breaker (HACR) Ampacity		Minimum Heating Blower Speed	
		240V	208V	240V	208V	Without HP	With HP
MAYHTR1A05BKR*	5	29.4	25.9	35	30	Low	Low
MAYHTR1A08BKR*	7.5	42.4	37.2	45	40	Low	Low
MAYHTR1A10BKR*	10	55.4	48.5	60	50	Low	Low
MAYHTR1A15BKR*	15	55.4/26.1	48.5/22.6	60/30	50/25	Low	Low
MAYHTR1A20BKR*	20	55.4/52.1	48.5/45.2	60/60	50/50	Low	Low

Note: Factory set at Medium Speed.

Motor Speed	AIR FLOW PERFORMANCE									
	M4AH4P44B1C00AA									
	External Static Pressure-Inches W.C. (kPa)									
		0(0)	0.1(.02)	0.2(.05)	0.3(.07)	0.4(.10)	0.5(.12)	0.6(.15)	0.7(.17)	0.8(.20)
Low	CFM	1272	1240	1202	1157	1114	1066	912	850.3	792
Medium	CFM	1570	1534	1490	1442	1387	1335	1278	1208	977
High	CFM	1780	1746	1704	1647	1570	1537	1405	1220	1166

# Mechanical Specifications

---

- Unique Cabinet Design
- Metal shell and glass cotton thermal insulation layer
- Multi-Position UP/Down Flow Horizontal Left /Right
- Braze in Refrigerant Connection
- Primary/Secondary Condensate Connections
- Blower with Integrated Slide Deck for Easy Removal
- Inner-groove aluminum tube and high-efficiency aluminum fin Coil with Integrated Slide Deck for Easy Removal
- More auxiliary Electric Heaters optional
- PSC 3 Speed Motor
- High Efficiency
- Integrated Horizontal Drain pans and metal Vertical Drain
- Fused 24V Power
- 5-Year Warranty.
- 10-Year Warranty Registered.
- Warranty Mirrors Outdoor.
- Optional extended warranty available.

Ameristar



The manufacturer has a policy of continuous product and product data improvement and it reserves the right to change design and specification without notice.

TAG: \_\_\_\_\_

## SUBMITTAL

### 4.0 Ton Multi-position Air Handler M4AH4P48B1C00AA

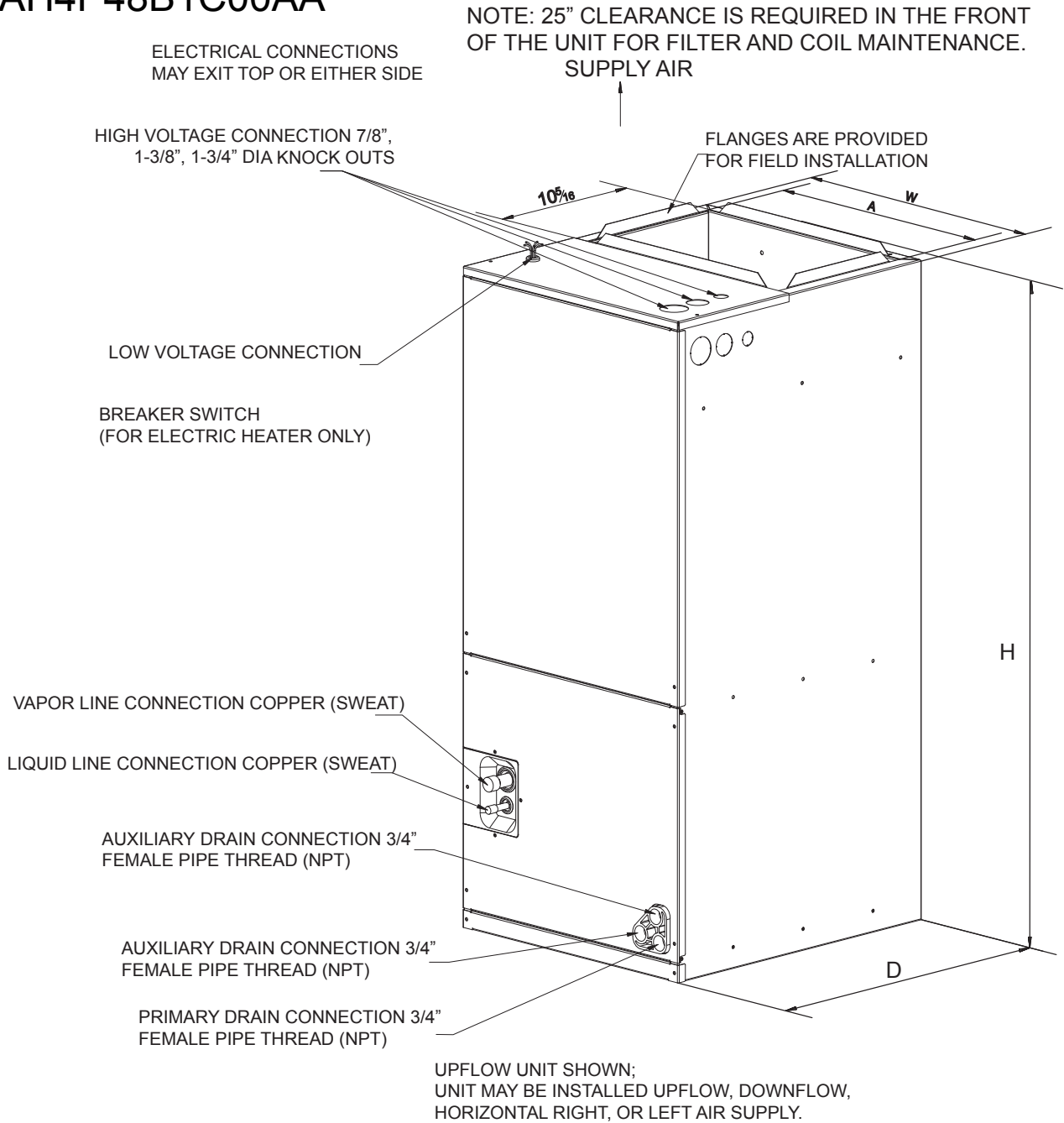

NOTE: All dimensions are in mm/inches.

Model	H	W	D	A
M4AH4P48B1C00AA	1385 (54-1/2)	560 (22)	610 (24)	496 (19-1/2)



# PRODUCT SPECIFICATIONS

## PRODUCT SPECIFICATIONS

MODEL	M4AH4P48B1C00AA
RATED VOLTS/PH/HZ.	208-230/1/60
RATINGS	See O.D. Specifications
INDOOR COIL — Type	Plate Fin
Rows — F.P.I.	4 - 17
Face Area (sq. ft.)	6.00
Tube Size (in.)	9/32
Refrigerant Control	Orifice
Drain Conn. Size (in.)	3/4 NPT
DUCT CONNECTIONS	See Outline Drawing
INDOOR FAN — Type	Centrifugal
Diameter-Width (In.)	10-5/8 X 10-3/4
No. Used	1
Drive - No. Speeds	Direct - 3
CFM vs. in. w.g.	See Fan Performance Table
No. Motors — H.P.	1 - 1/2
Motor Speed R.P.M.	1075
Volts/Ph/Hz	208-230/1/60
F.L. Amps	3.3
FILTER	
Filter Furnished?	No
Type Recommended	Throwaway
No.-Size-Thickness	1 - 20 X 22 - 1 in.
REFRIGERANT	R-410A
Ref. Line Connections	Brazed
Coupling or Conn. Size — in. Gas	7/8
Coupling or Conn. Size — in. Liq.	3/8
DIMENSIONS	H x W x D
Crated (In.)	55-4/5 x 25 x 27-7/10
Uncrated	54-1/2 x 22 x 24
WEIGHT	
Shipping (Lbs.)/Net (Lbs.)	177/159



**Intertek**



Heater Kit Model Used	Electric Heat (kW)	Min. Circuit Ampacity		Max. Fuse or Breaker (HACR) Ampacity		Minimum Heating Blower Speed	
		240V	208V	240V	208V	Without HP	With HP
MAYHTR1A05BKR*	5	30.3	26.8	35	30	Low	Low
MAYHTR1A08BKR*	7.5	43.3	38.1	45	40	Low	Low
MAYHTR1A10BKR*	10	56.3	49.4	60	50	Low	Low
MAYHTR1A15BKR*	15	56.3/26.1	49.4/22.6	60/30	50/25	Low	Low
MAYHTR1A20BKR*	20	56.3/52.1	49.4/45.2	60/60	50/50	Low	Low

Note: Factory set at Medium Speed.

Motor Speed	AIR FLOW PERFORMANCE									
	M4AH4P48B1C00AA									
	External Static Pressure-Inches W.C. (kPa)									
		0(0)	0.1(.02)	0.2(.05)	0.3(.07)	0.4(.10)	0.5(.12)	0.6(.15)	0.7(.17)	0.8(.20)
Low	CFM	1336	1310	1282	1234	1182	1140	1049	925	833
Medium	CFM	1654	1610	1569	1510	1461	1394	1350	1265	1034
High	CFM	1918	1875	1817	1771	1715	1651	1584	1511	1395

# Mechanical Specifications

---

- Unique Cabinet Design
- Metal shell and glass cotton thermal insulation layer
- Multi-Position UP/Down Flow Horizontal Left /Right
- Braze in Refrigerant Connection
- Primary/Secondary Condensate Connections
- Blower with Integrated Slide Deck for Easy Removal
- Inner-groove aluminum tube and high-efficiency aluminum fin Coil with Integrated Slide Deck for Easy Removal
- More auxiliary Electric Heaters optional
- PSC 3 Speed Motor
- High Efficiency
- Integrated Horizontal Drain pans and metal Vertical Drain
- Fused 24V Power
- 5-Year Warranty.
- 10-Year Warranty Registered.
- Warranty Mirrors Outdoor.
- Optional extended warranty available.

Ameristar



The manufacturer has a policy of continuous product and product data improvement and it reserves the right to change design and specification without notice.

TAG: \_\_\_\_\_

## SUBMITTAL

### 5.0 Ton Multi-position Air Handler M4AH4P60B1C00AA

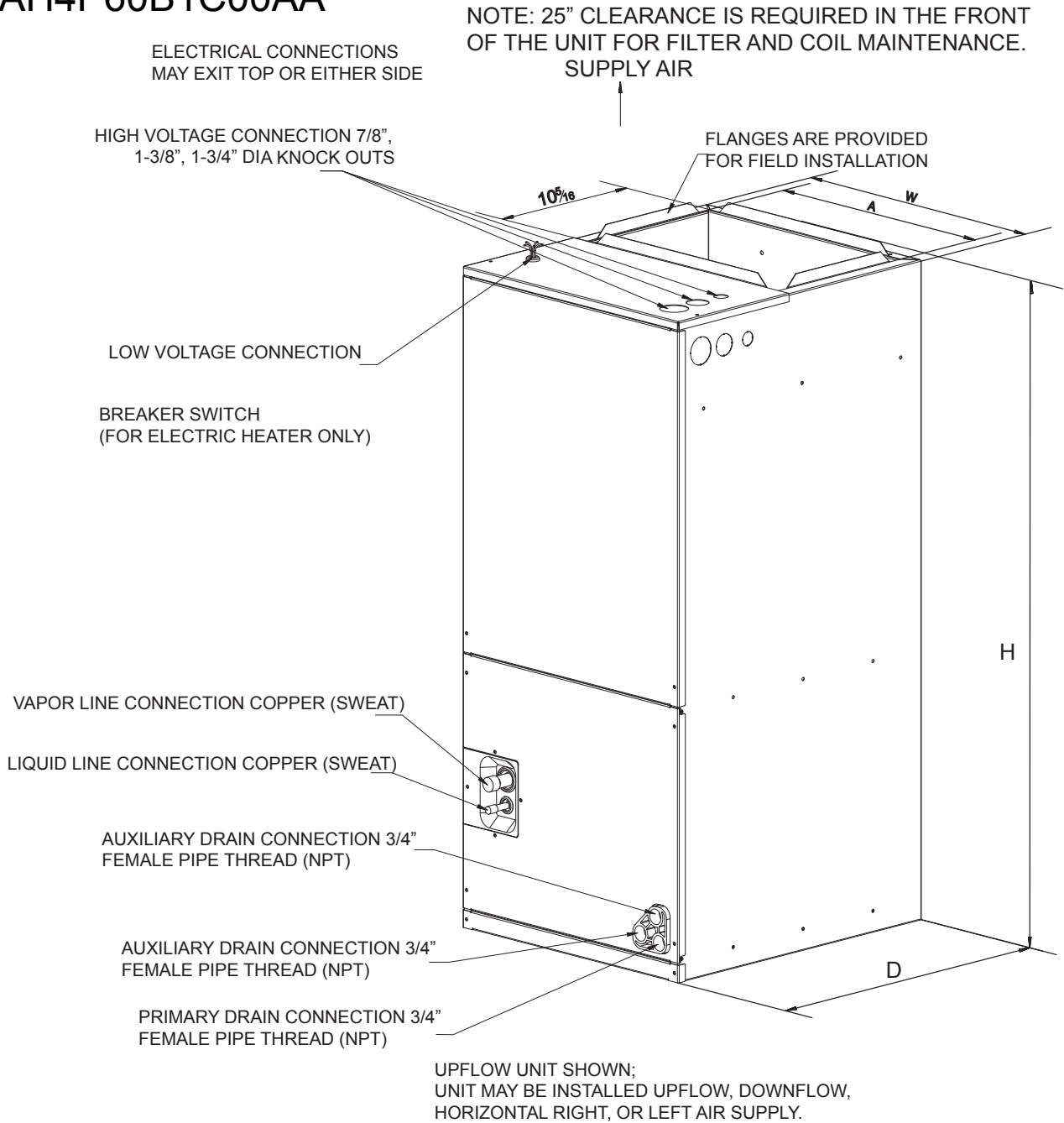

NOTE: All dimensions are in mm/inches.

Model	H	W	D	A
M4AH4P60B1C00AA	1385 (54-1/2)	560 (22)	610 (24)	496 (19-1/2)

# PRODUCT SPECIFICATIONS

## PRODUCT SPECIFICATIONS

MODEL	M4AH4P60B1C00AA
RATED VOLTS/PH/HZ.	208-230/1/60
RATINGS	See O.D. Specifications
INDOOR COIL — Type	Plate Fin
Rows — F.P.I.	4 - 17
Face Area (sq. ft.)	6.00
Tube Size (in.)	9/32
Refrigerant Control	Orifice
Drain Conn. Size (in.)	3/4 NPT
DUCT CONNECTIONS	See Outline Drawing
INDOOR FAN — Type	Centrifugal
Diameter-Width (In.)	10-5/8 X 10-3/4
No. Used	1
Drive - No. Speeds	Direct - 3
CFM vs. in. w.g.	See Fan Performance Table
No. Motors — H.P.	1 - 3/4
Motor Speed R.P.M.	1075
Volts/Ph/Hz	208-230/1/60
F.L. Amps	4.5
FILTER	
Filter Furnished?	No
Type Recommended	Throwaway
No.-Size-Thickness	1 - 20 X 22 - 1 in.
REFRIGERANT	R-410A
Ref. Line Connections	Brazed
Coupling or Conn. Size — in. Gas	7/8
Coupling or Conn. Size — in. Liq.	3/8
DIMENSIONS	H x W x D
Crated (In.)	55-4/5 x 25 x 27-7/10
Uncrated	54-1/2 x 22 x 24
WEIGHT	
Shipping (Lbs.)/Net (Lbs.)	177/159



Heater Kit Model Used	Electric Heat (kW)	Min. Circuit Ampacity		Max. Fuse or Breaker (HACR) Ampacity		Minimum Heating Blower Speed	
		240V	208V	240V	208V	Without HP	With HP
MAYHTR1A05BKR*	5	31.8	28.3	35	30	Low	Low
MAYHTR1A08BKR*	7.5	44.8	39.6	45	40	Low	Low
MAYHTR1A10BKR*	10	57.8	50.9	60	50	Low	Low
MAYHTR1A15BKR*	15	57.8/26.1	50.9/22.6	60/30	60/25	Low	Low
MAYHTR1A20BKR*	20	57.8/52.1	50.9/45.2	60/60	60/50	Low	Low

Note: Factory set at Medium Speed.

Motor Speed	AIR FLOW PERFORMANCE									
	M4AH4P60B1C00AA									
	External Static Pressure-Inches W.C. (kPa)									
		0(0)	0.1(.02)	0.2(.05)	0.3(.07)	0.4(.10)	0.5(.12)	0.6(.15)	0.7(.17)	0.8(.20)
Low	CFM	1737	1702	1675	1644	1604	1542	1483	1387	1159
Medium	CFM	2029	1987	1948	1883	1835	1776	1708	1621	1490
High	CFM	2216	2163	2105	2049	1987	1919	1841	1750	1623

# Mechanical Specifications

---

- Unique Cabinet Design
- Metal shell and glass cotton thermal insulation layer
- Multi-Position UP/Down Flow Horizontal Left /Right
- Braze in Refrigerant Connection
- Primary/Secondary Condensate Connections
- Blower with Integrated Slide Deck for Easy Removal
- Inner-groove aluminum tube and high-efficiency aluminum fin Coil with Integrated Slide Deck for Easy Removal
- More auxiliary Electric Heaters optional
- PSC 3 Speed Motor
- High Efficiency
- Integrated Horizontal Drain pans and metal Vertical Drain
- Fused 24V Power
- 5-Year Warranty.
- 10-Year Warranty Registered.
- Warranty Mirrors Outdoor.
- Optional extended warranty available.

Ameristar



The manufacturer has a policy of continuous product and product data improvement and it reserves the right to change design and specification without notice.