

# an illustrated guide to u-boat research

Simon Morris

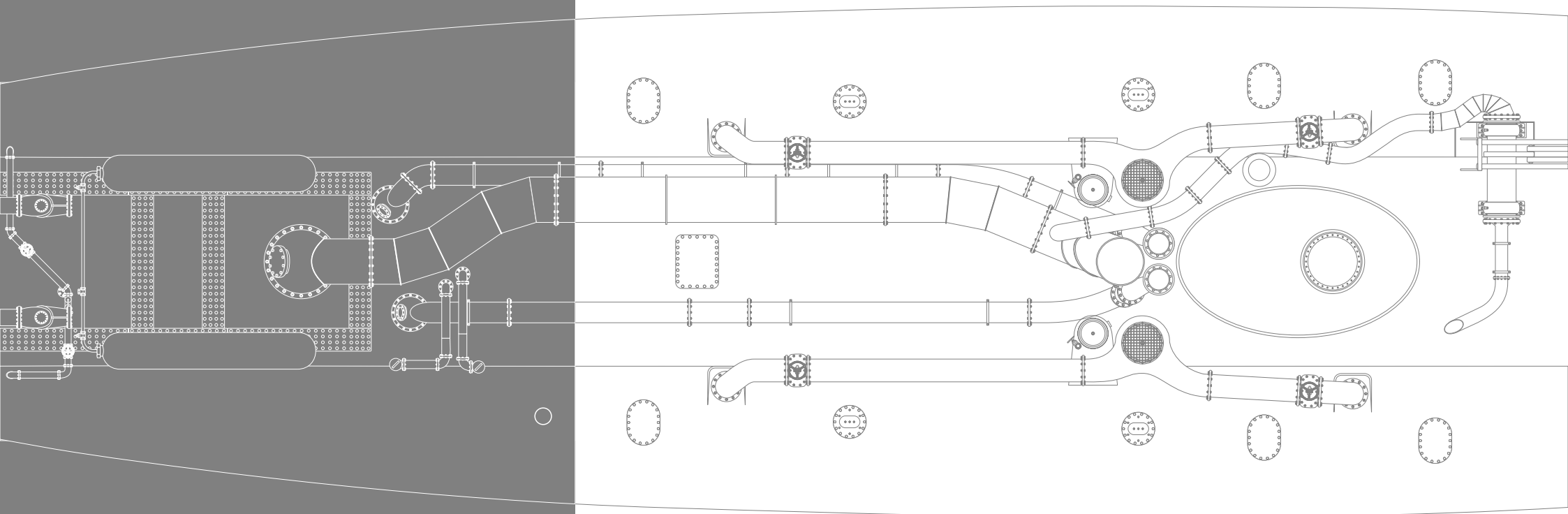

INTRODUCTION .....3

## U-BOAT TECHNOLOGIES

### PART I

DIRECTION FINDER ANTENNA LOOP .....4

### PART II

RADAR DETECTION ANTENNA .....5

### PART III

RADAR TRANSMITTER .....7

## THE U-BOAT

### PART IV

REFUELLING .....9

### PART V

SCHNORCHEL .....13

### PART VI

Alberich .....23

## U-BOAT WEAPONS

### PART VII

TWIN 3.7 CM FLAKZWILLING M43U .....24

## ACKNOWLEDGMENTS

This publication would not have been possible without the assistance of so many of my friends from all around the world. Special thanks must go to all the forum members at AMP - Accurate Model Parts who have provided much help and encouragement over the last three years.

I would also like to express my grateful thanks to the following individual for their assistance with my drawing of U-1308: Dani Janer Åkerberg (U-Historia), Jean-Luc Féraud (Trierarch), Maciej Florek, Wink Gris  (Accurate Model Parts), Dougie Martindale (Accurate Model Parts), Jerry Mason (U-boat Archive) and Dirk Richarz.

## A NOTE ON THE DRAWINGS

Most drawing can be view in lateral view (port view), anterior (bow view), posterior (stern view) and dorsal (Top View). All U-boats mention, unless indicated otherwise, are the Unterseeboot Type VIIC of the Kriegsmarine.

## COPYRIGHT

All rights reserved, No drawing of this publication may be reproduced without the prior written permission of copyright owner. Enquiries should be email to [simon.morris@xtra.co.nz](mailto:simon.morris@xtra.co.nz).

Saturday, 21 January 2012

All drawing   Copyright 2010-2012

Simon J Morris

The purposes of this illustrated guide to U-boat, is to assist modellers with were U-boats models, to present detail illustration of the U-boat technologies and equipment and to continue our fascination and eagerness to learn about the German U-boat.

The subjects within the document are a collection of my research topic associated with my drawing of U-1308. U-1308 was a Type VIIC/41 and also the last of her class, the Type VII submarine. This was because the Oberkommando der Marine or OKM, (the German naval high command), had decided near the end of World War II to put all of its resources into building the newer types of Unterseeboot, such as the types XXI and XXIII. U-1308 was built at Flensburger Schiffbau-Gesellschaft, Flensburg and was commissioned on 17 January 1945. As U-1308 was the last Type VII, the Kriegsmarine fitted her out to be arguable the most advanced U-boat of her class. U-1308 was one of nine Type VIIs that the Kriegsmarine fitted with an experimental synthetic rubber skin of anechoic tiles known as Alberich, which had been designed to counter the Allies' asdic/sonar devices. U-1308 was also one of two Type VIIC/41s that was equipped with a new design of passive sonar hydrophones, thus increasing detection ranges by approximately 70% over the older designs. Nevertheless, a few days before Germany surrendered U-1308 was taken approximately 5 km (3.1 mi) north-west of Warnemünde and scuttled on 2 May.

The topics in this document cover a large range of things and for the most part covered the late war Type

VIIC's. Topics cover U-boat technologies and illustrate the development of the equipment throughout the war. In addition, other topics cover some rarer aspects of the U-boat. Only the essential details are given about each newest style or design, as the primary purposes is document is to be an illustrated guide. Additional information on all the topics cover in this document can be found in any good U-boat books or on the internet.

This document is a work in progress, additional drawings and topics will be added. If any inaccuracies in a drawing are found, the drawings will be updated. Furthermore, of additional details are found afterwards that will increase the accuracy of a drawing, this new detail will be added. There are a few absent drawings within the document these drawing will be added at a later data after additional research is completed.

The Direction Finder Antenna Loop was located on the starboard side of the bridge. It was used to detect and get bearings from the radio signals of Allied surface ships. There are two known style found on the Type VIIC's, an early-war and a late-war versions. The loop in both versions are the same diameter of approximately 800 mm. The only visible different between the two versions is the additional antenna added along the centreline of the antenna loop. This additional antenna is approximately 2,300 mm in height and is attach to the base of the antenna loop.

There is a sub-style of the early-war version, four extra rounded nodes are found on the antenna loop. The four extra rounded nodes are a leftover from the FuMB-26 Tunis radar detector antenna.

## NOTES OF THE DRAWINGS

All drawings on this page are scaled at 1: 32.

### STYLE 1- EARLY WAR

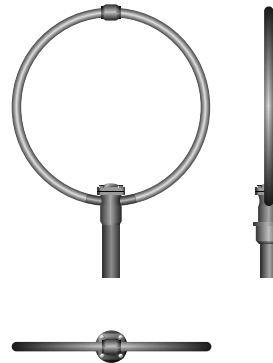

### STYLE 2- LATE WAR

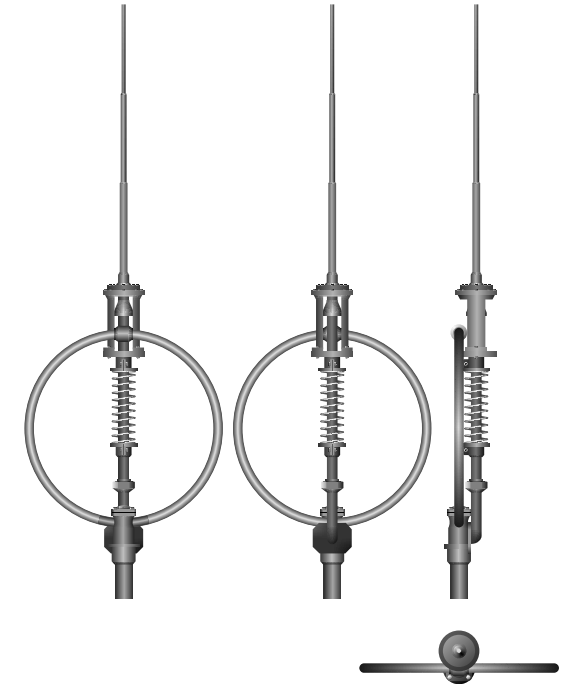

### STYLE 1a- EARLY WAR WITH FuMB REMOVE

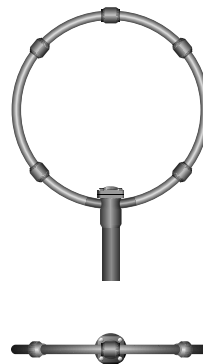

## FuMB ANT. 2 - HONDURAS

The FuMB Ant. 2 - Honduras antenna was used with the FuMB-1 Metox radar detection. This rudimentary antenna consisted of five pieces of wood tied together into a cross, with wires wrapped around it. It was installed into a bracket on the conning tower and was periodically rotated by hand. The FuMB-1 was the first operational German radar detector to be used on U-boats. It was manufactured by French company, Grandin and Sadir. It was installed in U-boats from August 1942 to July 1943. The FuMB-1 was tuned to pick up wavelengths of the British naval type 286 and the airborne ASV Mk. I/II radars. The initial FuMB-1 used the FuMB Ant. 2 - Honduras antenna later this antenna was replaced by the FuMB Ant. 3 - Bali I.

## FuMB ANT. 3 - BALI I

The FuMB Ant. 3 - Bali I antenna was used with the FuMB-1 Metox, FuMB-7 Naxos U, FuMB-8 Cypern I, FuMB-9 Cypern II and the FuMB-10 Borkum radar detections. The vertical polarized on the FuMB Ant. 3 - Bali I antenna have a total height of 300 mm and a diameter of 9 mm. The diameter of the fixed round net-type dipole is 250 mm.

## FuMB ANT. 5 - SAMOA

The FuMB Ant. 5 - Samoa antenna was mounted on the backside of FuMO-30 radar antenna and was used with the FuMB-4 Samoa radar detection. The FuMB-4 was manufacturer

German company Rohde & Schwarz. The FuMB Ant. 5 - Samoa antenna was introduced at end of 1943 and replaced the FuMB-1 on U-boats equipped with FuMO-30 Gema radar.

## NOTES OF THE DRAWINGS

Most drawing on this page are scaled at 1: 32, with the exception the FuMB Ant. 3 - Bali I antenna which is scale at 1: 16.

## FuMB ANT. 2 - HONDURAS

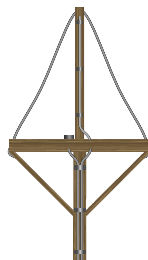

## FuMB ANT. 3 - BALI I



## FuMB ANT. 5 - SAMOA

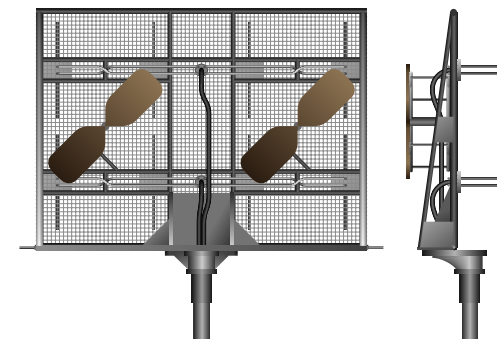

## FuMB Ant. 11 FINGER

The FuMB Ant. 11 - Finger antenna was first used with the FuMB 7 Naxos. This antenna was not waterproof or pressure tight and had to be manually rotated. It is believe that this antenna look the same as FuMB Ant. 24 Fliege antenna.

## FuMB ANT. 24 CUBA IA - FLIEGE

The FuMB Ant. 24 - Cuba IA - Fliege antenna was initially mounted in the Direction Finder Antenna Loop and later in a separate mounting on the bridge. In addition, FuMB Ant. 24 antenna was used with the FuMB-26 Tunis radar detections

## FuMB ANT. 25 CUBA II - MÜCKE

The FuMB Ant. 25 Cuba II - Mücke antenna was initially separately mounting on the bridge and afterwards it was used with the FuMB-26 Tunis radar detections.

## FuMB 26 - TUNIS

FuMB 26 - Tunis combined the FuMB Ant. 24 Fliege and FuMB Ant. 25 Cuba II antennas. It was mounted in both the Direction Finder Antenna Loop and separately on the bridge.

## FuMB-35 - ATHOS I

The FuMB-35 was the final design of radar detection for the Type VIIC, as the FuMB-37 Leros, was only used on the Type XXI. The FuMB-35 was manufacturer German company Telefunken and NVK. The antenna was a cylinder-shaped water/pressure resistant array

of circular loop antennas.

## NOTES OF THE DRAWINGS

All drawings on this page are scaled at 1: 32.

### FuMB ANT. 11 - FINGER

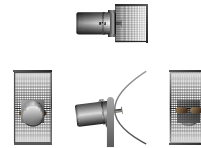

### FuMB ANT. 25 CUBA II - MÜCKE

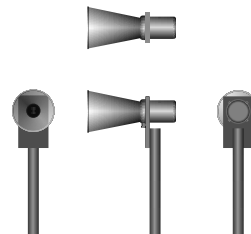

## FuMB 26 - TUNIS

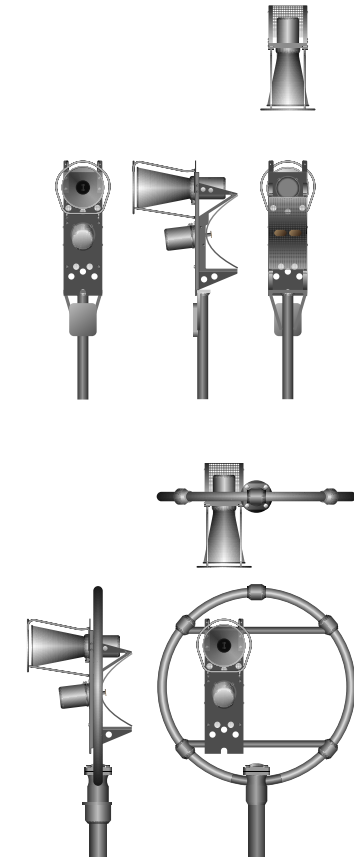

## FuMB35 - ATHOS

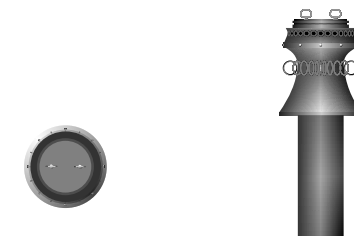

## FuMO-29 GEMA

The first U-boat radar was a conversion of a ship borne radar intended for surface ships. It was installed beginning in 1942 in a few Type VIIIs and IXs. This set had very narrow detection coverage of 10 degrees on each side of the bow, which meant that the U-boat had to make an almost complete circle to cover a 360 degree sweep. The range was 7.5 km against surface vessels and 15 km against aircraft.

## FuMO-30

Essentially the same set as the FuMO-29, the only difference being the antenna. The antenna utilized a rotatable antenna which had to be manually turned by a hand wheel in the radio room. Introduced in between late 1942 and early 1943, the antenna consisted of two rows of four dipoles. The antenna was mounted on the port side of the conning tower and was retracted into a slot when not in use. Range was slightly increased up to 8 km. The FuMO-30 was built into all U-boats, but was not popular with U-boat crews because of its limited effectiveness and high detection chance. It was used until March 1944.

The FuMO-30 antenna was 1,400 mm (55 in) wide by 1,000 mm (39 in) in height, the total overall dimensions of the antenna frame was 1,540 mm (61 in) wide and 1,022 mm (40.2 in).

## NOTES OF THE DRAWINGS

All drawings on this page are scaled at 1: 32.

## FuMO-30 RADAR TRANSMITTER

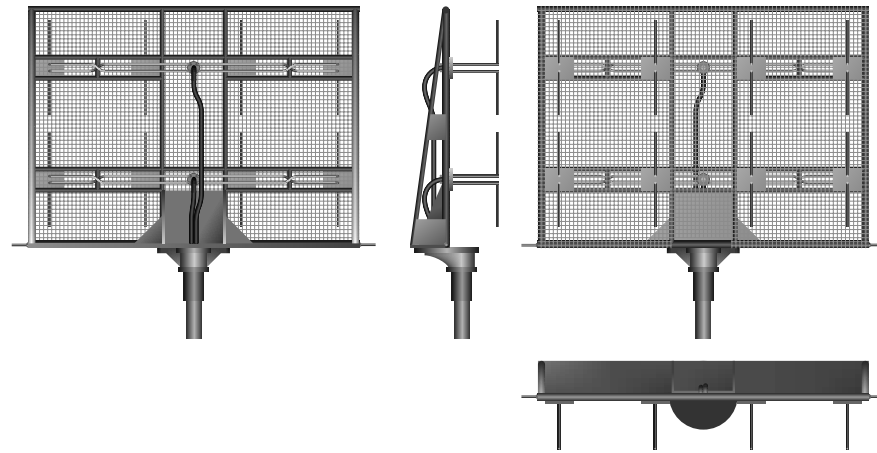
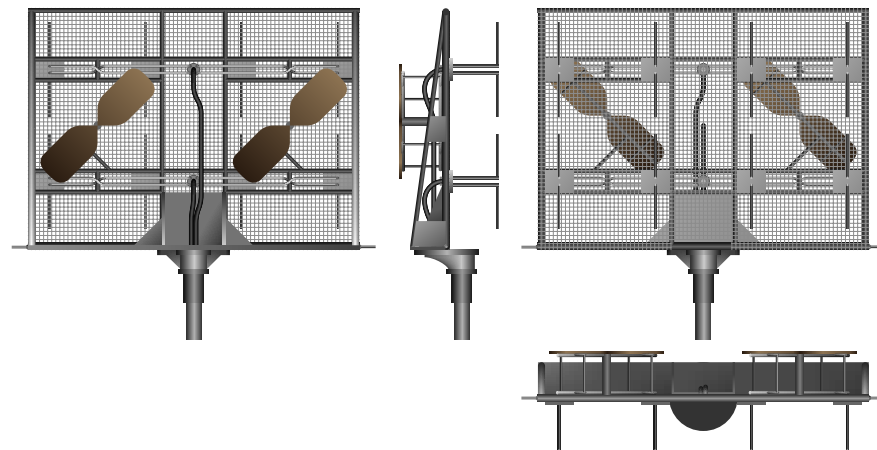
FuMO-30 RADAR TRANSMITTER WITH  
FuMB ANT. 5 SAMOA ANTENNA FOR THE FuMB-4 RADAR DETECTION

## FuMO 61 Hohentwiel U & FuMO 65 Hohentwiel U1

In 1943 Lorentz was instructed to adapt Hohentwiel for naval use, and soon the Hohentwiel appeared on U-boats, small surface ships, and coastal installations. There are two U-boat versions of the FuG 200 Hohentwiel used during World War 2; FuMO 61 Hohentwiel U and the FuMO 65 Hohentwiel U1. The U-boat versions were easier to maintain and more reliable compare to the other versions. However, the U-boat versions had several disadvantage, the smaller dimension of the antenna and the height of the antenna installation. The antenna was restricted to a smaller dimension as it had to fit within a small area on the port side of the conning tower. In addition, the reduce height of the installation of the antenna, affected the range of the radar. The range of both U-boat versions was between 8 and 10 kilometres (5.0 and 6.2 mi) for naval targets and between 15 and 25 kilometres (9.3 and 16 mi) at an altitude of 200 metres (660 ft). Resolution was about 3 degrees, and at short range its range accuracy was 100 metres (330 ft). Both U-boat versions work at a frequency 556 MHz and had four rows of six dipoles. While the U-boat was submerged the antenna was retracted into a well on the conning tower. Both U-boat versions of the antennas were 1,400 millimetres (55 in) wide by 1,000 millimetres (39 in) in height, the total overall dimensions of the antenna frame was 1,540 millimetres (61 in) wide and 1,022 millimetres (40.2 in). There are two types of radar transmitter for the FuMO-61 Hohentwiel U and FuMO-65 Hohentwiel U1, the

Type F431 C1 and the Type F432 D2. The Type F431 C1 was used on the Type VII and the Type F432 D2 on the Type XXI.

### NOTES OF THE DRAWING

All drawings on this page are scaled at 1: 32.

### FuMO-61 HOHENTWIEL U RADAR TRANSMITTER TYPE F431 C1

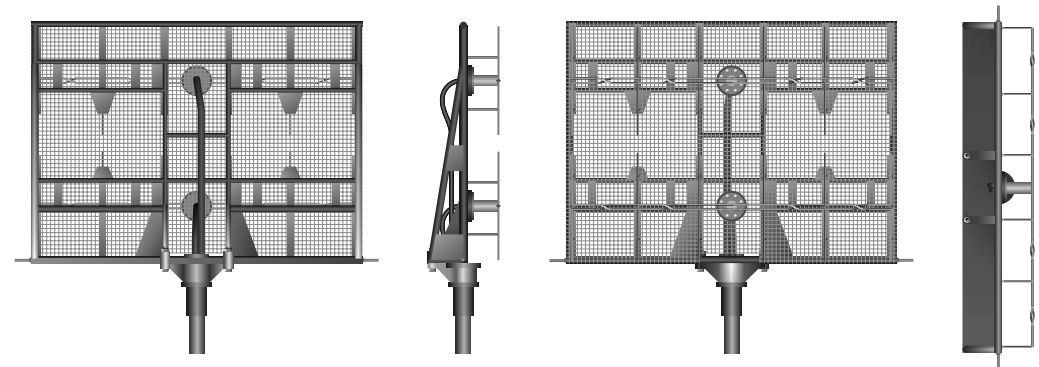

### FuMO-61 HOHENTWIEL U RADAR TRANSMITTER TYPE F432 D2

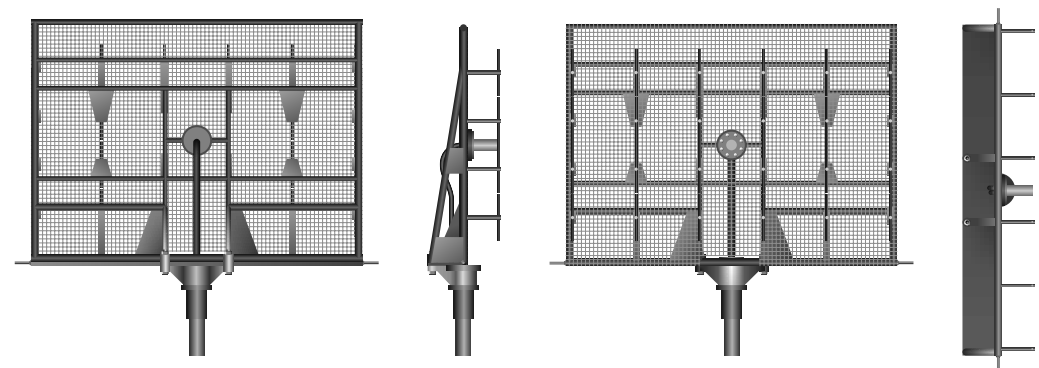



The requirement for underwater refuelling was the consequence of several issues, the increasing airpower in the Atlantic by the Allies, and the Oberkommando der Marine (OKM) endeavour to keep the U-boats on patrol as long as possible. Consequently testing and field trials were performed during 1943. The OKM must have put a lot of significant into underwater refuelling as Type VIIC's with Atlantic bow were being modified before the testing was fully finished. However, we never observe the widespread use of underwater refuelling during the war. This was because of the Allies systematic hunting and sinking of the U-boat tankers Milchkuh/Milchkühe (Milk cows) during 1942 and 1943. All but one U-boat tanker was lost by August 1943.

U-boats identified with this modification for underwater refuelling are listed below. There are eight known U-boats with this alteration. They are from five different building yards, and were launched between September 1943 and March 1944. It is uncertain if any new U-boat launched after March 1944 or especially the 'late-war' Type VIIC/41 were modified for underwater refuelling. However, it would seem doubtful that these U-boats were modified for underwater refuelling for the reasons that all but one U-boat tanker were destroyed and no new U-boat tankers were being built to replace the lost boats. Furthermore, the OKM had decided near the end of World War II to put all of its resources into building newer types of Unterseeboot, such as the types XXI and XXIII.

- U-249 (VIIC - Launched October 1943 from F. Krupp Germaniawerft AG, Kiel).
- U-481 (VIIC - Launched September 1943 from Deutsche Werke AG, Kiel).
- U-766 (VIIC - Launched May 1943 from Kriegsmarinewerft, Wilhelmshaven).
- U-776 (VIIC - Launched March 1944 from Kriegsmarinewerft, Wilhelmshaven).
- U-1023 (VIIC/41 - May 1944 from Blohm & Voss, Hamburg).
- U-1056 (VIIC - Launched March 1944 F. Krupp Germaniawerft AG, Kiel).
- U-1060 (VIIF - Launched Mar 1943 from F. Krupp Germaniawerft AG, Kiel).
- U-1165 (VIIC/41 - Launched July 1943 from Danziger Werft AG, Danzig).

## UNDERWATER REFUELLING SYSTEM

Little is known about the design of this alteration to the Atlantic bow. Nevertheless, we can get an impression of this alteration to the bow from several observations made by U-boat crew members and wartime photographs of U-boats with this bow.

The radio antenna cable attachment point had to be shifted from the centre of the towing eye to the right side of the towing eye to allow for the fuel hose. A number of different designs to fix antenna cables were used by U-boat building yards or on individual batches of newly built U-boats.

There are no known descriptions of the fuel hose used

for the underwater fuelling nevertheless we can get an impression of its base on the fuel hose used for the transfer of fuel oil to U-boats at sea. The underwater fuelling hose would have had an approximately internal diameter of 90 mm and be made up of various lengths of hoses connected together. Two sections approximately 8 m in length of armoured hose were used to prevent damage through chafing, where the hoses leave the supply U-boat and refuelling U-boat. There are no documents known that prove evidence that lubricating oil was also transferred underwater.

A telephone link was found to be more reliable than an underwater telegraphy, and a pressure tight socket for the telephone had been obtained from the captured British submarine HMS Seal (N37). The telephone cable run along the full length of fuel hose, and was attached used canvas bands approximately 200 mm wide at intervals of approximately every metre along the fuel hose.

## UNDERWATER REFUELLING OBSERVATIONS

Below are several observations about the initial field trials with underwater refuelling.

From: U-977 by Heinz Schaeffer, W. W. Norton & Company Inc, New York. Page 129-134

7 December 1942

"The chief engineer and some of the engine-room staff went forward and aft to open the fuelling valves and clear the way for the supply-hose". The weather was so bad and men were "washed overboard and only be hauled in again with a good deal of effort". U-445 cruised "parallel to the supply-boat, perhaps 90 yards away. A line was fired over us by pistol, and this was followed by the hose and a towing-wire". The supply-boat was U-460, then "for security reasons and also to test our manoeuvrability under water we both dived; first the supply-boat, then ourselves. The two boats preceded one astern of the other with lines, hose and wire left in place, and so we cruised for three hours on end at a depth of 25 fathoms". Course and speed signals were exchanged by underwater telegraphy.

Note: An initial look at U-460 Kriegstagebuch (KTB) War Diary/War Log Book for the 7th of December 1942, does not mention any underwater refuelling. This could be evidence that an error with the above date, and/or the U-boat numbers. It is anticipated at a later date, a more detail search of KTB will sort this out.

Form: Navy Department Office of the Chief of Naval

Operations Washington. Final Report – G/Serial 42. Report on the interrogation of survivors from U-490 sunk 12 June 1944.

"Supplying U-Boats While Submerged", Page 20.

"Prisoners stated that the Engineer Officer of U-490 had made a study of the problem of transferring fuel oil from one U-boat to another while submerged. During the tactical exercises in July 1943, this officer actually practiced submerged supplying from the Dutch submarine UD-5. The prisoners knew almost nothing about the procedure employed. They believed that hose and cable connections between the two boats were made on the surface. A telephone connection was then established and the boats submerged after which oil was pumped from one to the other. A warrant machinist stated that U-490 was to have been fitted in Bordeaux with the necessary gear for underwater supplying. He did not know of what this gear consisted, other than a valve in the control room for regulating the flow of oil.

Form: The U-boat: The Evolution and Technical History of German Submarines. By Eberhard Rossler. Cassell, 1974 (German), 1981/2001 (English)

Field trials were held with UD-4, travelling on the surface at a constant speed; a buoy was released with a towing hawser, hose and telephone cable. The hose was filled with air so that towing hawser and telephone cable floated. The buoy was taken aboard the receiving boat, the towing hawser was made fast and the hose was connected. Both U-boats would

then go to periscope depth. After the transfer of fuel the two U-boats would resurface simultaneously, the receiving U-boat let go the buoy and turned directly to port.

## NOTES OF THE DRAWINGS

The drawings on the follow page illustrate the configuration and alignments of the Atlantic Bow which was modified for underwater refuelling. All drawings on this page are scaled at 1: 32. The drawings of the Atlantic Bows are currently not fully completed. High-quality photographs of these bows are needed to add additional items and to verify alignments. The deck steel plates and rivets alignments need to be verify and there is a hatch immediately aft of the Towing Eye that needs to be added to the drawing and verify.

## ATLANTIC BOW MODIFIED FOR UNDERWATER REFUELLING

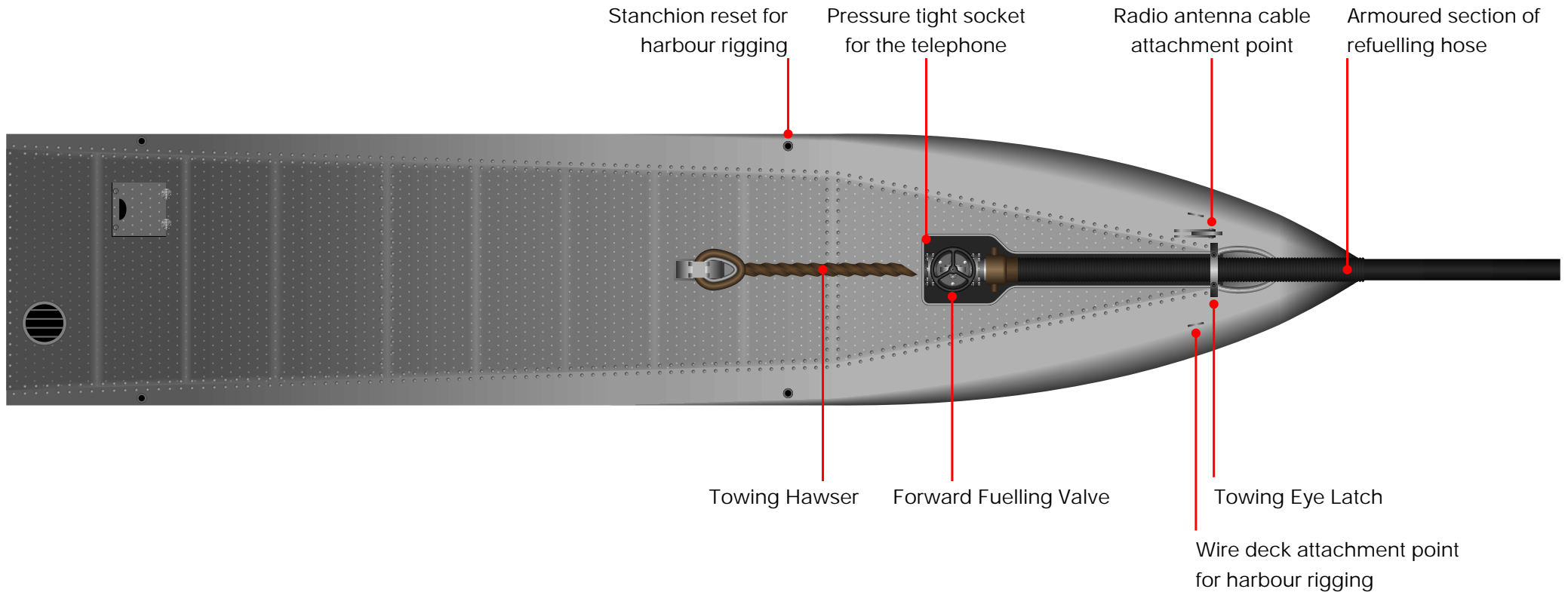

### NOTES OF THE DRAWINGS

All drawings on this page are scaled at 1: 24. All drawings on the follow page are scaled at 1: 32. The drawings of the Atlantic Bows are currently not fully completed. High-quality photographs of these bows are necessitate to add additional items and to verify alignments. The deck steel plates and rivets alignments need to be verify and there is a hatch immediately aft of the Towing Eye that needs to be added to the drawing and verify.

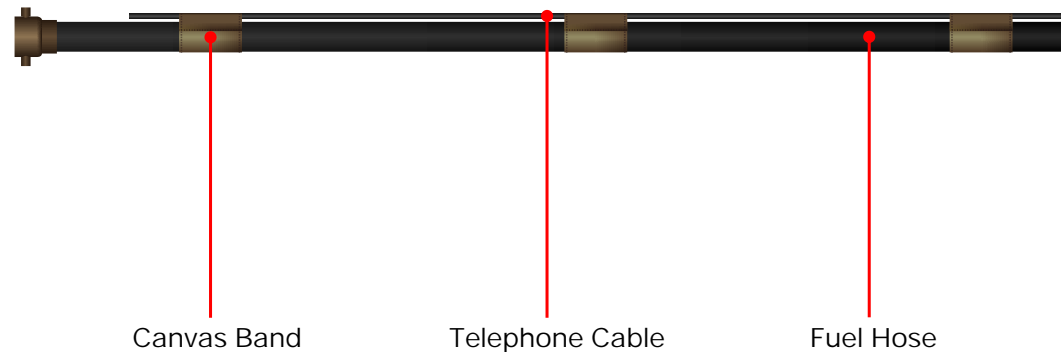

ORIGINAL TYPE VIIC BOW

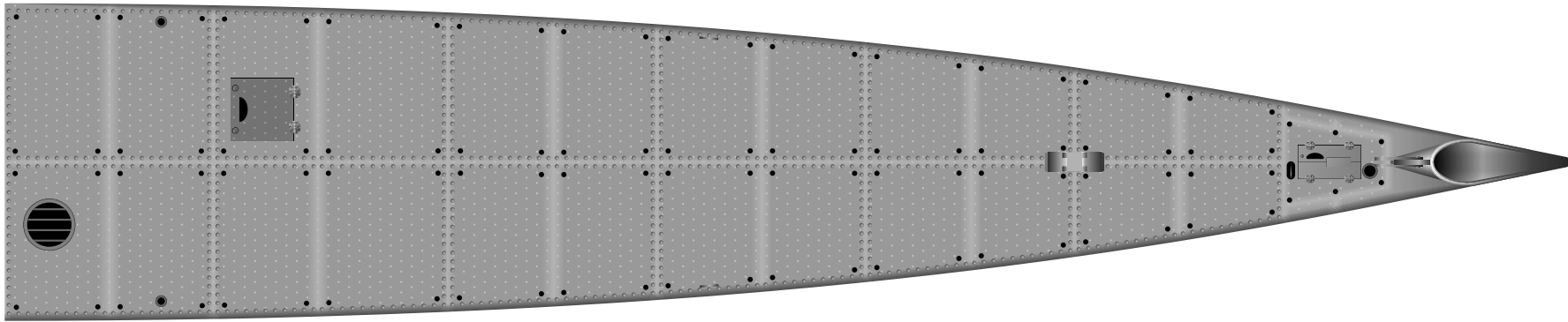

ORIGINAL ATLANTIC BOW

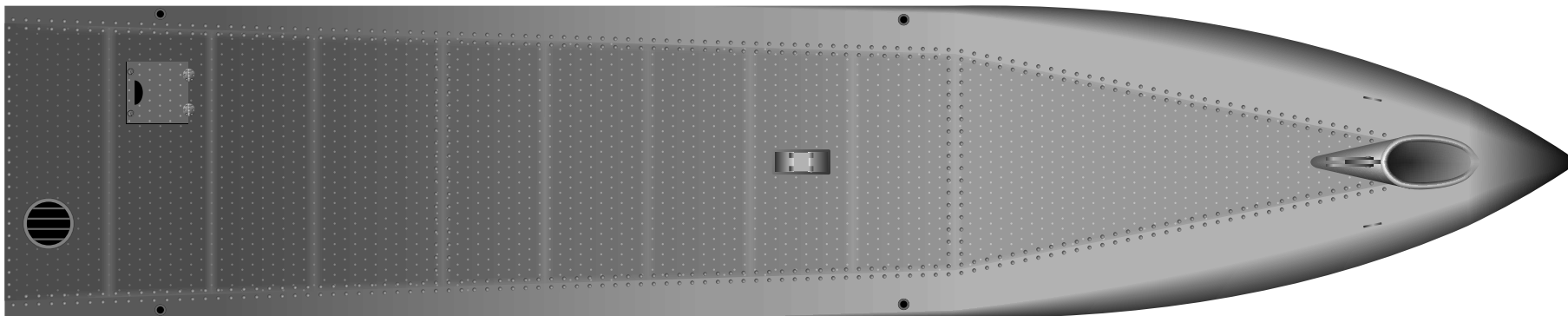

The German's initially saw very little requirement for the Schnorchel at the beginning of the war. It was not until March 1943 that research, development and construction of the Schnorchel really started because of the increasing threat to the U-boat from the air. The objective of the Schnorchel was to introduce atmospheric air while the U-boat was just below the surface, thought an extensible air-shaft so enable the used of the diesel engine. An additional advantage was the capable of charging the air bottles while using the Schnorchel.

Constructional drawings were ready for the first version of the Schnorchel head, a flooding valve arrangement and send to Deutsche Werke on 8 June 1943. The Schnorchel was tested on U-57 & U-58 during August 1943. For this test the Schnorchel replace the aft periscope. The initial testing was successful and a collapsible Schnorchel forward of the bridge was envisaged for the Type VIIC boats.

## ANTI-RADAR COATING

Two anti-radar materials were used on the Schnorchel head and neck by the German Kriegsmarine during World War II. The anti-radar coating was glued onto the metal surface of the head valve and the smaller stem tube below, above the exhaust outlet.

## JAUMANN

Jaumann-type anti-radar coating was far better at absorbing radar radiation but due to difficult manufacturing it was not flexible and could only be

made in flat sheets or in round forms. It was made up of 7 layers of conductive material separated by layers of dielectric material. The layered absorber measured about 7cm in thickness and was only used on the Schnorchel head.

## WESCH

Wesch-type anti-radar coating 'Tarnmatte' was designed to be effective against the H2S radar. It was made from 2 cm thick sheets of a synthetic rubber called Buna that contained iron oxid powder. It was very flexible and had a waffle-like surface. Normally only applied to the curved structure of Style 4 - Ball float schnorkel head, however, it was occasionally also fitted to other Schnorkel head like Style 2- Ring-float Schnorkel head. The coating was used on both Schnorchel head and neck.

## SCHNORCHEL HINGE

The schnorchel hinge arrangement is located just forward of the bridge, and a reset has been cut out of the port side saddle tank to attach the hinge base to the pressure hull.

## SCHNORCHEL PISTON

There is some suggesting that there are two styles of schnorchel piston found on the Type VIIC's, an 'Loop' design as seen in most photographs and a 'streamline' design as see on some plans and drawings. However, this research indicates that there is only one schnorchel piston design, the 'Loop' design.

It is believe that incorrect plans, poor quality photographs, the current configuration of U-995 and the Type VIIC Revell Models all had leaded to the suggest of a second 'streamline' schnorchel piston and pipe design. U-995 in it current configuration exhibit this 'streamline' piston design, but the current schnorchel system aboard this boat is not the original schnorchel piston. Nearly all of the original schnorchel system aboard this boat has been replaced or is missing. In photographs on page 141 & 146 of U 995: Das Boot von dem Marine-Ehrenmal in Laboe by Eckard Wetzel; you can clearly see the original schnorchel system.

Schnorchel mast is raise and lowed by the Schnorchel piston that is controlled by two hand wheels in the control room which activate a hydraulic mechanism. One hand-wheel is turned to "Open" for rising, when the Schnorchel is to be lowered, this wheel must be in the "Closed" position and the other wheel turned to "Open".

## STYLE 1 - TESTING

Style 1 was the first design to be used on the Type VIIC's for testing purposes. This style was only used on two boats U-235 and U-236 during September 1943. The Schnorchel neck was approximately 350 mm in diameter and was slightly smaller than the other styles of Schnorchel necks. The exhaust outlet was located approximately 1,200 mm from the top.

## STYLE 2 - RING-FLOAT

Style 2 is the most common Schnorchel head seen during War World II. Depending on the anti-radar material used the dimension of the Schnorchel head differ. With the Jaumann-type anti-radar coating the head had a diameter of 580 mm and with the Wesch-type anti-radar coating the head had a diameter of just 450 mm. Both were of the same height of 680 mm. The Schnorchel head coating with the Jaumann-type did not have its neck coated with any anti-radar material. The Schnorchel head coating with the Wesch-type also had its neck coated in the same anti-radar material.

The Schnorchel neck does not appear to be attached to the mast of the Schnorchel with a standard flange with nuts and bolts like the other styles. A FuMB Ant. 3 - Bali I antenna sits centrally on top of the Schnorchel head.

## NOTES OF THE DRAWINGS

Style 2 is viewed with both the Jaumann-type (left) and Wesch-type (right) anti-radar coating. All drawings on this page are scaled at 1:43¼.

## STYLE 1- TESTING

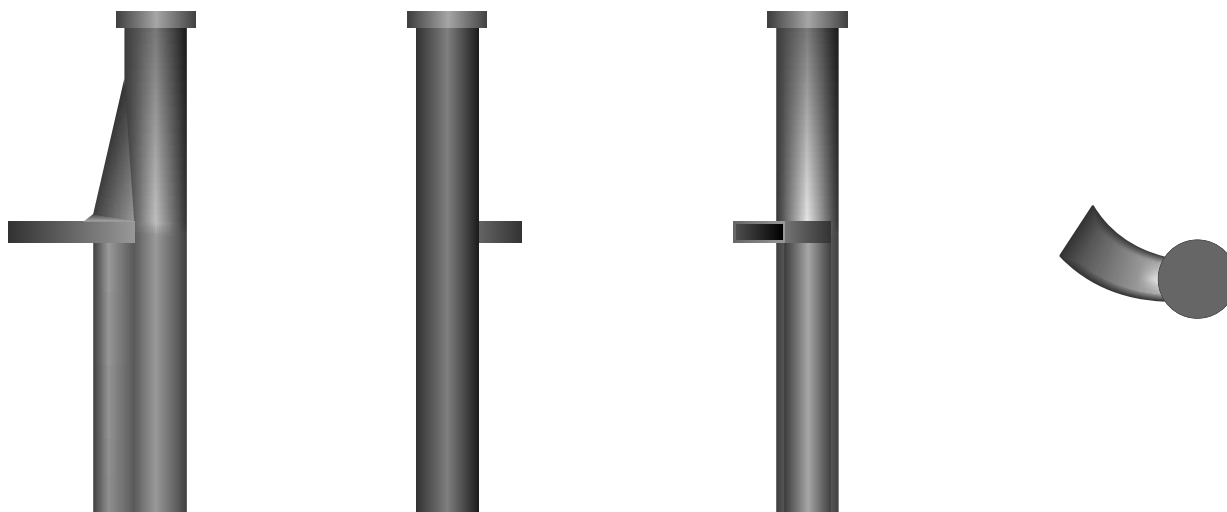

## STYLE 2 - RING-FLOAT



STARBOARD VIEW

FORWARD VIEW

STERN VIEW

TOP VIEW

## STYLE 3 - RING-FLOAT

Style 3 is of similar design to style 2, with a wider diameter Schnorchel head ( $\varnothing$  450 mm; h 180 mm) sitting at the very top of the Schnorchel neck ( $\varnothing$  350 mm; h 1,200 mm). The neck is attached to the masts of the Schnorchel by a flange with nuts and bolts. A FuMB Ant. 3 - Bali I antenna sits on the side of the very top of the Schnorchel head. The wiring runs down the side of the neck of the schnorchel, and then enters the schnorchel mast and exits near the schnorchel hinge arrangement. U-boats known to used the style include U-481.

## STYLE 3 -RING-FLOAT

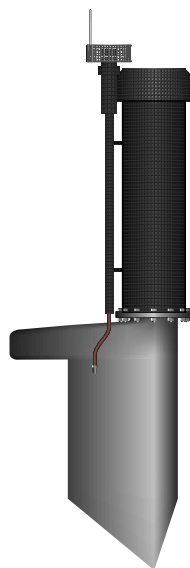

## STYLE 4 - BALL FLOAT

Style 4 was the final design for Schnorchel head for the Type VIIC's. The Schnorchel head sits atop of a narrower diameter Schnorchel neck ( $\varnothing$  225 mm; h 1,060 mm). The Schnorchel neck is attached to the masts of the Schnorchel by a flange with nuts and bolts. A large floating valve structure can be seen under the Schnorchel head cover to the aft of the head (1,000 mm  $\times$  355 mm). A FuMB Ant. 3 - Bali I antenna sits on the side of the very top of the Schnorchel head. The wiring runs down the side of the neck of the schnorchel, and then enter the schnorchel mast and exits near the schnorchel hinge arrangement.

## STYLE 4 - BALL FLOAT

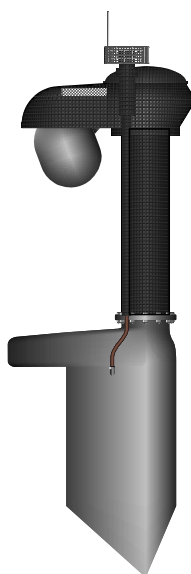

## NOTES OF THE DRAWING

All drawings on this page are scaled at 1: 43¼.

STARBOARD VIEW

FORWARD VIEW

STERN VIEW

TOP VIEW

Both the Type VII's and IX's had a folding Schnorchel, on the Type VII's it is located on the port side, while on the Type IX's the mast was on the starboard side. The Type XXI and XXIII both had periscopic masts (they raised vertically through the conning tower casting). Three styles are known for the Type VIIC's.

## STYLE 1

This style was on build for testing purpose on the repair boats of U-234 and U-235 in September of 1943. There is some unsure of the true shape of the fly wheel that control the rising & lower the mast, this is due no photographs of this area.

The schnorchel mast had the air inlet pipe forward and the exhaust outlet pipe was behind the air inlet pipe. When the schnorchel not in use, it is lowered forward into a groove in the deck grating.

## NOTES OF THE DRAWINGS

All drawings on this page are scaled at 1: 73.

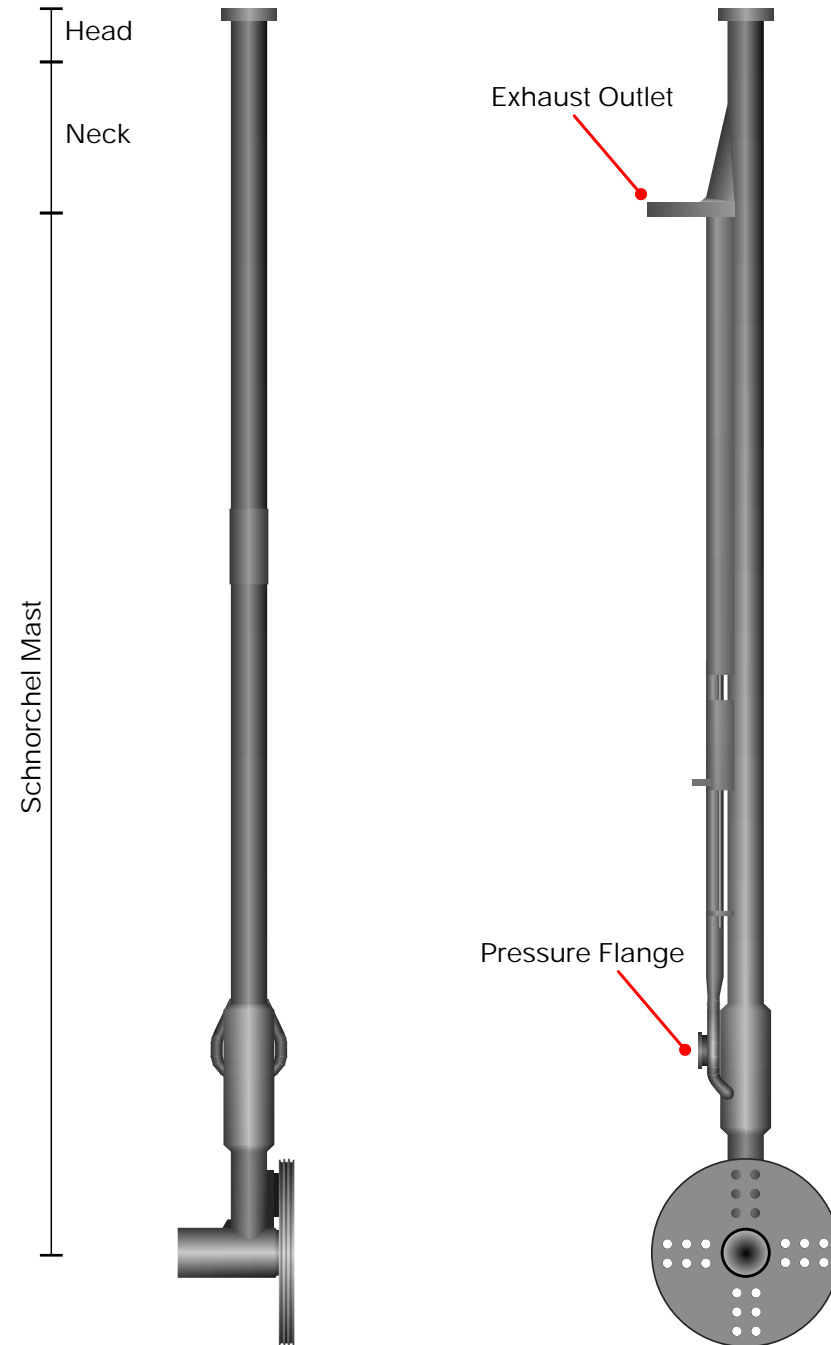



## STYLE 2

This design of the Schnorchel mast is the most commonly found on the Type VII's. This style was installed up to autumn 1944. The Schnorchel mast was fixed with a half-height pressure flange connection to the diesel air intake pipe along the port side of the conning tower casing. The pressure flange was connected to a section of the air inlet pipe that runs under the spray deflector on the outside of the conning tower. A control arm was located just aft of the pressure flange and is used to operate a valve to stop sea water entering the Main Air Trunk line.

The Schnorchel mast profile is hydrodynamic, resembling a teardrop shape. The forward part being rounded with the aft part pointed. When the Schnorchel mast not in use, it is lowered forward into a groove in the deck grating.

## NOTES OF THE DRAWINGS

All drawings on this page are scaled at 1: 53½.

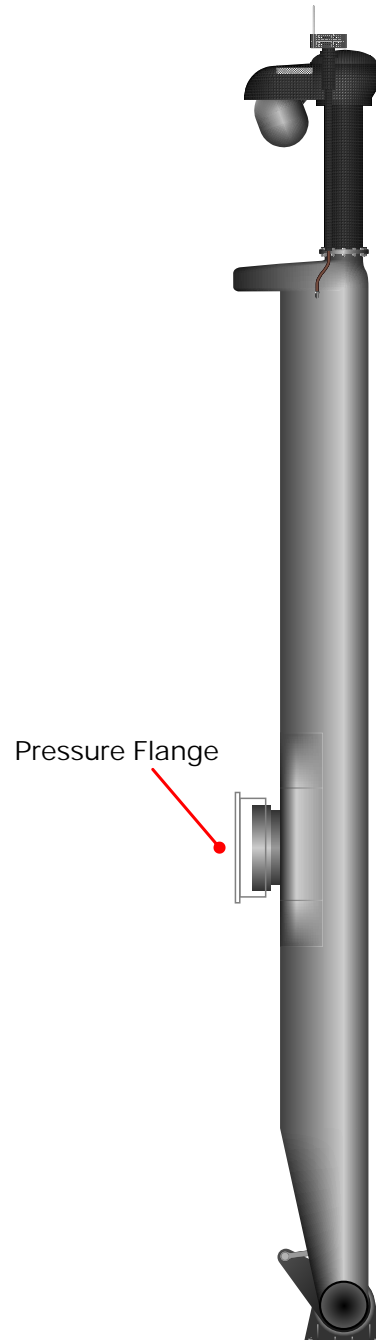

## STYLE 3

This was the final design of the Schnorchel mast and is commonly found on the late war Type VII's. This style see the diesel air intake pipe being part of the Schnorchel hinge arrangement.

The Schnorchel mast profile is hydrodynamic, resembling a teardrop shape. The forward part being rounded with the aft part pointed. When the Schnorchel is not being used it is lowered forward into a groove in the deck grating.

## NOTES OF THE DRAWINGS

The drawings of the Schnorchel mast is scaled at 1:53½ and the Schnorchel mast hinge arrangement is at 1:32.

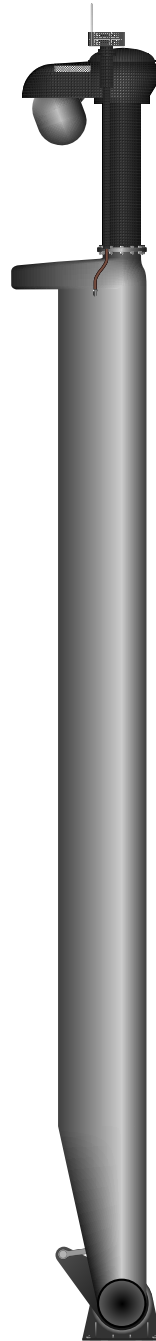

## STYLE 3 SCHNORCHEL HINGE ARRANGEMENT

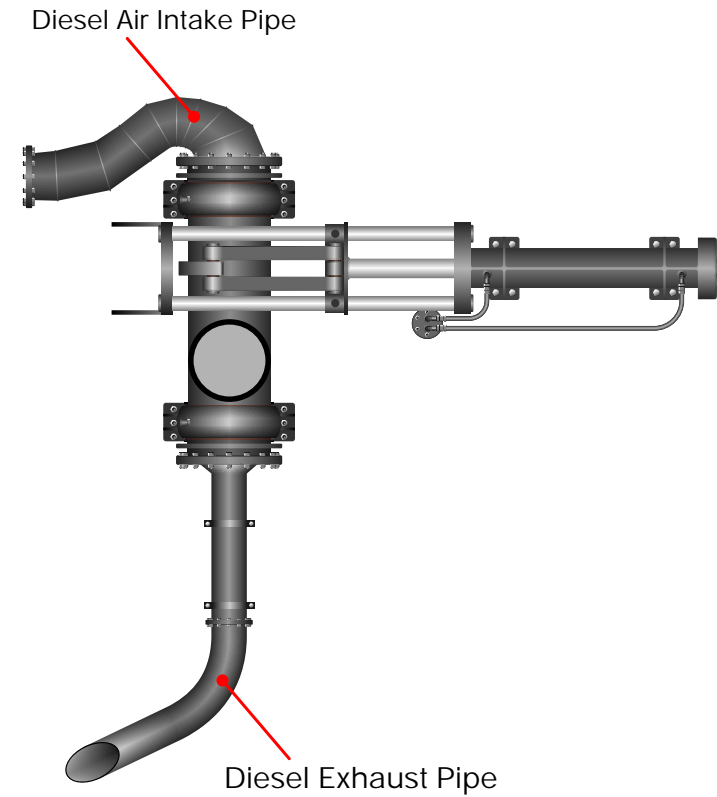

When the mast is upright it is contain within the Schnorchel restrain bracket, which located at the top of the conning tower. The schnorchel mast is locked into position by a large locking pin, which is control from within the Control Room. A control arm extent from the Control Room, through the pressure hull, up the conning tower to the schnorchel restrain bracket. There are two known arrangement styles for this control arm.

## STYLE 1

The control arm run through the spray deflector then along the outside of the conning tower unshielded to the deck.

## STYLE 2

The control arm run through the spray deflector then is shielded by a larger half round diameter pipe to the deck.

## NOTES OF THE DRAWINGS

Drawings to be added later after additional research.

The Schnorchel air outlet pipe is location along the starboard side of the Type VII's. It carries exhaust gases to the schnorchel from the engine room. Almost all of the piping is found under the wooden decking, however a small section found above deck next to the conning tower. There has been some uncertainty if this section of pipe above deck is found all Type VIIC's. It was believe to be absent on some Type VIIC's with a schnorchel. This research indicates that this section of piping is found on all Type VIIC's with a schnorchel. This uncertainty is probable due to U-995 (Type VIIC/41) as in it current configuration this pipe is absent. Nevertheless, it can be seen in it original configuration on page 147 of U 995: Das Boot von dem Marine-Ehrenmal in Laboe by Eckard Wetzel. Most plans or drawings illustrate this section of piping very poorly and it is very easily miss or misinterpret

In the schnorchel mast, the exhaust pipe, is approximately 20 cm in diameter and runs up the inside to within 1½ meters of the top. There it emerges and projects aft for about 40 to 50 cm.

## NOTES OF THE DRAWINGS

All drawings on this page are scaled at 1: 32.

### ABOVE DECK PIPING - TOP VIEW

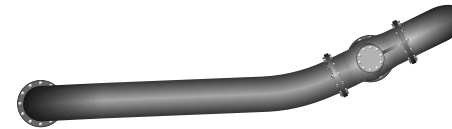

### BELOW DECK PIPING - SIDE VIEW

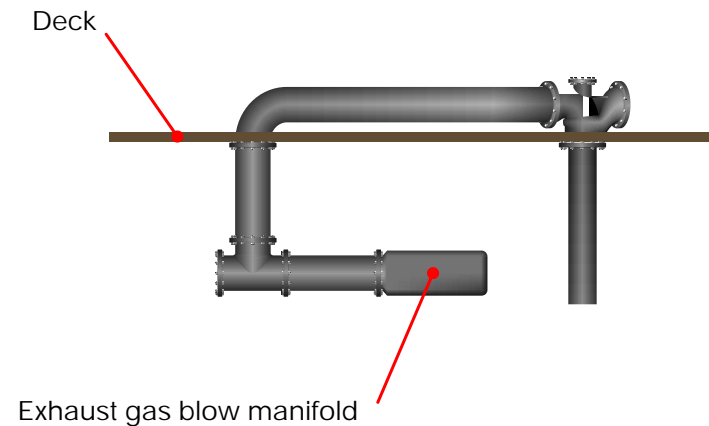

The Schnorchel air inlet piping is located on the port side of the Type VII's and carries clean air to the Main Air Inlet Trunk line. The Schnorchel air inlet piping either runs outside of the conning tower casing or is found under the decking depending on the style. A control arm was located aft of the pressure flange and is used to operate a valve to stop sea water entering the Main Air Inlet Trunk line while the schnorchel is not being used.

## STYLE 1 - TESTING

This style was first used for testing purposes on the repair boats of U-234 and U-235 in September of 1943. A few other U-boats continued using this older design during the war, they include U-boat U-275. In this style the Schnorchel mast was fixed with a one-third height pressure flange. From the pressure flange air intake pipe was laid out upward to the spray deflector and then run under the spray deflector along the outside of the port side of the conning tower.

A control arm and valve are located between the radar drive shaft and prior to the Air Inlet pipe enters the upper Wintergarten casing. The control arm is operated from inside the Control Room.

## NOTES OF THE DRAWINGS

Drawings to be added later after additional research.

## STYLE 2 - ABOVE DECK

This is the most commonly style that is found in the wartime photographs. This style was installed up to autumn 1944. The Schnorchel mast was fixed with a half height pressure flange. From the pressure flange the air intake pipe was lay out under the spray deflector along the outside of the port side of the conning tower. U-boats known to use this design include U-275, U-826 and U-1105 (VIIC/41).

## STYLE 2a - ABOVE DECK

A very slight variation on style 2 is found on several U-boats, this variation see the air intake pipe being layout at the same high of the spray deflector. U-boats known to use this variation include U-1009 (VIIC/41) & U-1202.

A control arm and valve are located between the radar drive shaft and prior to the Air Inlet pipe enters the upper Wintergarten casting. The control arm of operated from into the Control Room.

## NOTES OF THE DRAWINGS

Drawings to be added later after additional research.

## STYLE 3 - BELOW DECK

This was the final design for the air inlet pipe, and in this design we see the majority of pipeing under the decking. The inlet is now part of the schnorchel hinge arrangement. The pipe exit the port side of the schnorchel hinge arrangement with a section of curve pipe extending pass the side wall of the deck approximately 220 mm. An opening in the side decking cast has been cut out (700 mm × 320 mm) the enable for the bend. The remaining of the air inlet pipe weave around the drive shaft for the radar aerial and the piping for the blowing of Tank 2 & 4. U-boats known to use this design include U-249, U-278, U-481, U-766, U-776 & U-1305 (VIIC/41).

## NOTES OF THE DRAWINGS

Drawings to be added later after additional research.

The technology of anechoic tiles was developed by the Kriegsmarine in the Second World War. Codenamed Alberich after the invisible sorcerer from Germanic Mythology. The coating was made up of sheets approximately 1 m (3 ft 3 in) square and 4 mm (0.16 in) thick, with rows of holes in two sizes, 4 mm (0.16 in) and 2 mm (0.079 in) in diameter. It was manufactured by IG Farben from a material known as Oppanol. The material was not homogeneous but contained air cavities; it was these cavities that degraded the reflection of ASDIC. The coating worked in the 10 to 18 kHz range, reducing ASDIC return by about 15%. This frequency range matched the operating range of the early ASDIC active sonar used by the Allies. The ASDIC types 123, 123A, 144 and 145 all operated in the 14 to 22 kHz range. However, this degradation in echo reflection was not uniform at all diving depths due to the voids being compressed by the water pressure. An additional benefit of the coating was it acted as a sound dampener, containing the U-boat's own engine noises.

The coating had its first sea trials in 1940, on U-11 (Type IIB). U-67 (Type IX), was the first operational U-boat with this coating. After her first war patrol, she put in at Wilhelmshaven probably sometime in April 1941 where she was given the coating, it covered the conning tower and sides of the U-boat, but not to the deck. By 15 May 1941, U-67 (Type IX) was in Kiel performing tests in the Baltic Sea. During July, the coating was removed from all parts of the boat except the conning tower and bow. Further experiments and sound trials were made in the Little Belt but they

presumably proved unsatisfactory, as all the coating was subsequently removed. Problems were encountered early-on, when the adhesive was found to be not strong enough to stick the synthetic rubber sheets to the pressure hull and casing of the U-boat. This resulted in the sheets loosening and creating turbulence in the water, making it easier for the submarine to be detected.[9] Furthermore, the coating was found to have considerably decreased the speed of the boat. It was not until late 1944 that the problems with the adhesive were mostly resolved. The coating required a special adhesive and careful application; it took several thousand hours of glueing and riveting on the U-boat. The first U-boat to test the new adhesive was U-480. With good results with the new adhesive, the Oberkommando der Marine intended that it would be widely used on the new Type XXI and Type XXII U-boats. However, the war ended before it could be put into large scale use. Ultimately only one operational Type XXIII, U-4709, was coated with the anechoic tiles.

U-boats with the anechoic tiles coating include: U-11, U-480, U-485 U-486, U-1105, U-1106, U-1107, U-1304, U-1306, U-1308, U-4704, U-4708 and U-4709.

## NOTES OF THE DRAWINGS

All drawings on this page are scaled at 1: 1¼.

## ALBERICH

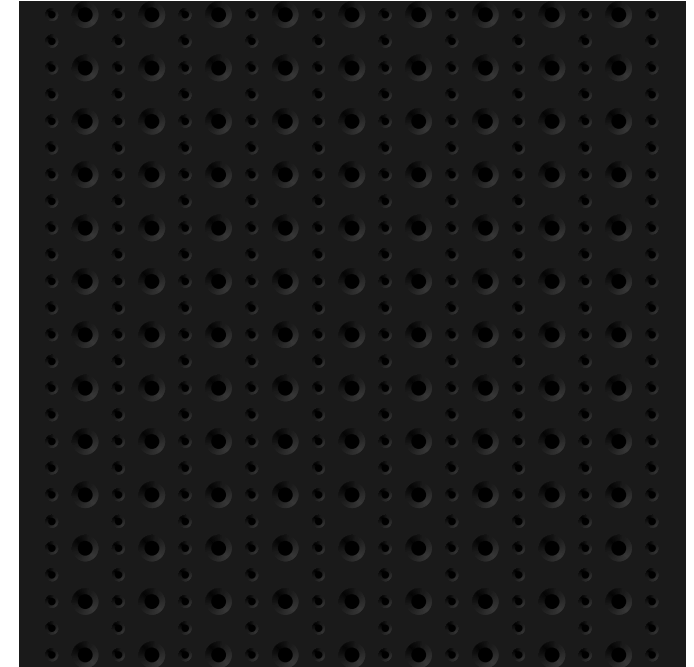



The 3.7 cm Flakzwilling 43 M43U was the marine version of the 3.7 cm Flakzwilling 43 used by the Kriegsmarine on Type VII and Type IX U-boats. It was mounted on the LM42U mount. The rare twin 3.7 cm Flakzwilling M43U was one of the best anti-aircraft weapons used by the German Kriegsmarine during World War II. It was mainly used on the Type IX as it was rather heavy for the Type VII U-boats.

U-boats known to have this version of anti aircraft weapon include U-190 (Type XIC/40), U-534 (Type IXC/40), U-858 (Type IXC/40), U-870 (Type IXC/40), U-873 (Type IXD2), U-889 (Type IXC/40) and U-1168 (Type VIIC/41).

## NOTES OF THE DRAWING

All drawings on this page are scaled at 1: 32.

## TWIN 3.7 CM FLAKWILLING M43 U

