

TITAN DT



IMS Engineered Products is

ISO 9001 Certified



Designed and
Manufactured in the USA

Titan DT Series Catalog



AMCO[®]
ENCLOSURES
an IMS Engineered Products Brand

About Us

AMCO Enclosures has been a leader in the development of enclosure and mounting systems for over seven decades. Our innovations have become the standard for housing electronics and data systems over that time, trusted by companies and institutions providing services that touch virtually every aspect of your daily life.

From military installations to banks and hospitals, AMCO Enclosures provides stability and security for the information your world runs on.

Today's Data Centers

Today's data centers store and process massive amounts of information and financial transactions calculated in milliseconds. Faster computing requirements call for faster servers, creating the need for more power. More power means higher heat loads. Increased cabling means higher-density packaging in the server rack, driving thermal thresholds to new heights. Heat, power and cabling become critical elements in managing overall performance efficiency.

Total cost of ownership looms large when designing and creating tomorrow's data centers. AMCO addresses these issues with its flexible framing platform, the Titan DT racks. Integrated power, cabling and cooling solutions are standard on Titan DT server racks, and make complex data center management simpler.



Customization

Although the Titan DT offers millions of standard configurations, many of our customers take advantage of our ability to customize our racks in a very short amount of time at a reasonable cost. If you are looking for a custom size rack, unique color, private branding or a custom cable raceway you can work directly with our engineering department to design a solution specifically for you. Our team will make design recommendations to improve airflow, cable management, cost and overall functionality, while never compromising on quality and performance. Once a cabinet is designed and shipped for the first time, subsequent shipments can be ready in as little as two weeks. Stocking programs are also available to ensure that your cabinets are ready when you need them.



Online Configurator

Use this catalog as a guide to design your rack online.

AMCO Enclosures' online configurator for server racks provides you with maximum results in a minimal amount of time. Our product configurator is simple, fast and accurate. It is easy to learn, has no cost and no software to run.

Design your racking system in a few quick and simple steps. Choose a cabinet size (H x W x D), and the image adjusts to your specifications. Continue by adding available accessories.

Specify exact RU locations for your rack accessories for maximum design flexibility. Add notes to the configuration as required.

Results Include

- Bill of material for specific configuration (includes product descriptions and weights)
- Saved configurations for reference and future updates
- Quote based on specified configuration
- Unique configuration number for your specific bill of materials



Note: 3D cabinet included in configuration

Titan DT Overview

About Titan DT

The Titan DT is extremely flexible, featuring an extensive selection of rack heights, widths, depths and color choices that target your specific design requirements. Select the door, top panel, side panel and mounting channel options to complete your rack design. Modified or custom rack designs are available by contacting your local AMCO sales representative or contacting us directly at 847-391-8100.

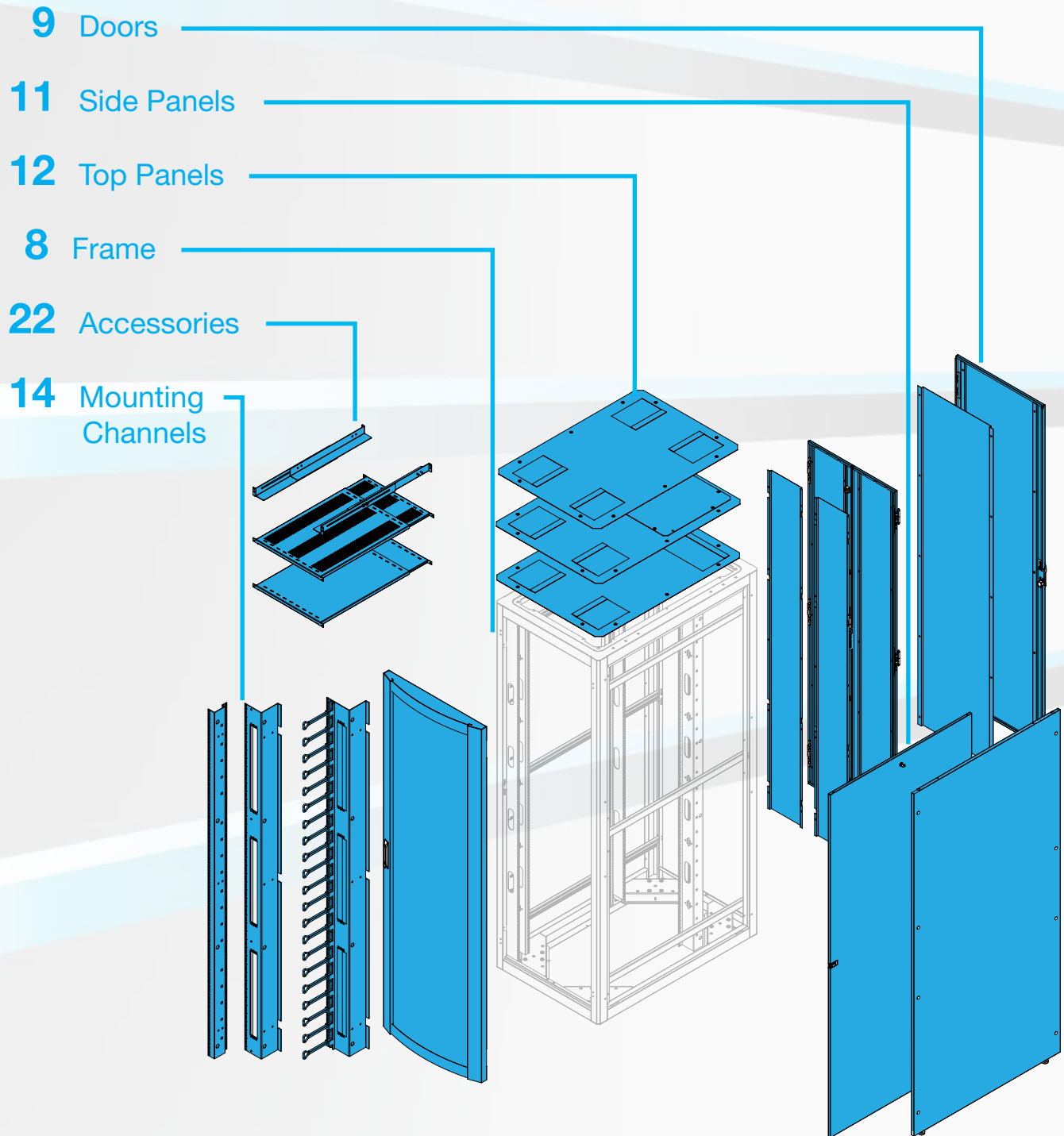

External Features



Top Panels

Top panels come in a variety of designs. M6 pattern in rack's hat section is for cable tray deployment.



Design

Titan DT racks feature a contemporary design aesthetic with a radius design that blends well in almost every IT environment.



Latch

Side panels feature spring latches that slide to open/close and hold side panels in place.



Doors

Curved-face mount doors feature a radius design aesthetic while providing a 77% open pattern to maximize airflow to IT equipment.



Door Hinge

Doors are reversible (left-handed/right-handed) with an easy on/off hinging system.



**UL LISTED • 5,400 LBS. LOAD RATING
RACKS BUILT UP TO 62 RU, 32" W AND 48" D**



Internal Features



Cable Management

Cable management fingers are made of 9 gauge wire, have 6" of usable space and are available with fingers at every RU or every other RU for larger cable bundles.



Channels

Mounting channels feature universal (square-hole) mounting, providing flexibility in metric/domestic hardware deployment.



Accessories

Titan DT racks have the flexibility to expand to meet the evolving requirements of the IT landscape.



Side Struts

Titan DT side struts feature uni-strut side channel design, providing fully adjustable front-to-rear equipment mounting without removing channels.

Frame Base Construction

The Titan DT base has multiple forms and is enhanced with four caster brackets that encase casters for added protection and support.

Below Base



Above Base

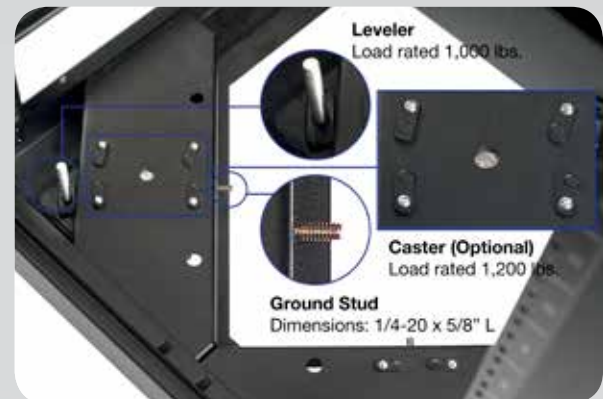

Multiple-Bay Joining - Fast & Simple

Titan DT racks can be joined together with simple hardware to form multi-bay consoles. No complex joining systems or structures are required—simple nut and bolt hardware makes multiple-bay joining fast and easy. Joining hardware is included with every rack.



Frames

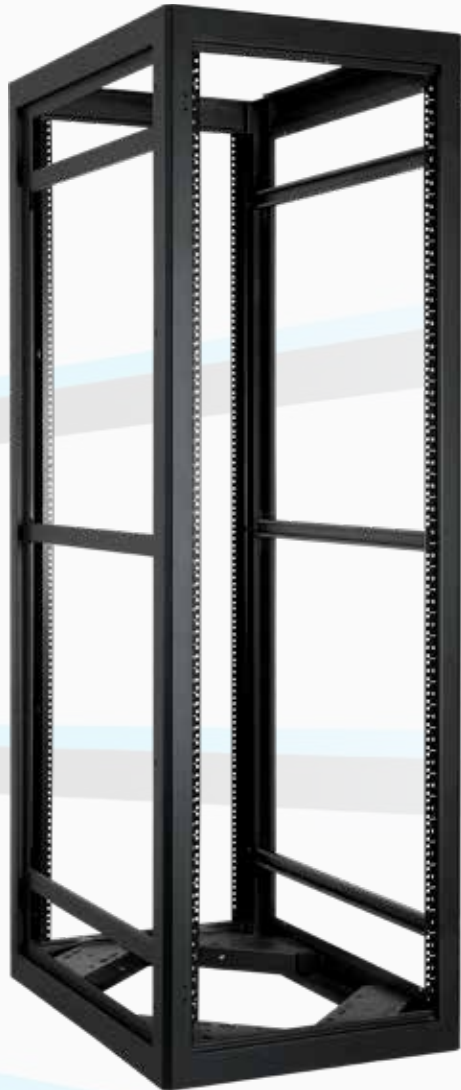

Frames

Titan DT frames provide exceptional support for your IT infrastructure. Our fully welded frames have the highest load ratings in the industry. Our extensive selection of mounting channels expands the frame's mounting capabilities.

Certified Load Ratings

- Static: 5,400 lbs.
- Dynamic: 3,300 lbs.

Standards

- ISO 9001
- UL listed up to 62 RU, 32" wide and 48" deep
- GSA Contract Holder
- EIA 310
- Certified to MIL STD 901 (Shock) and MIL STD 810 (Vibration)
- Ten year warranty

Frames Include

- Contemporary Design Aesthetic
- Four ground studs in each corner of the base for grounding
- Four 1,000 lb. leg levelers for ground support
- Fully adjustable mounting channels provide more precise, front-to-rear equipment adjustments

24" Width Frames

RU Height	42" Depth	45" Depth	48" Depth
52	R-TN-52U24-42	R-TN-52U24-45	R-TN-52U24-48
48	R-TN-48U24-42	R-TN-48U24-45	R-TN-48U24-48
44	R-TN-44U24-42	R-TN-44U24-45	R-TN-44U24-48
42	R-TN-42U24-42	R-TN-42U24-45	R-TN-42U24-48

*Note: For 29" width, change "24" to "29" in part number.
(i.e. R-TN-52U24-45 becomes R-TN-52U29-45)*

*For 32" width, change "24" to "32" in part number.
(i.e. R-TN-52U24-45 becomes R-TN-52U32-45)*

Frame Color Options

Pottery White 101-T	Light Blue 111-T	Silver 112-T	Gunmetal 113-T	Black 116-T	Pearl Gray 122-T	Pebble Gray 123-T	Light Beige 125-T	Cranberry 126-T	Medium Blue 816-T	Glacier White XCP-151T

Note: AMCO Enclosures offers standard color choices (up to 2 per console) for no extra charge. Custom colors are available and quoted upon request.



Doors



Curved-Face

Vented-Flush

French-Flush

Doors

Titan DT vented doors are available in either face or flush mount options. Face mount doors mount to the rack's exterior surface. Flush mount doors mount flush to the exterior of the frame. French doors are available to decrease swing radius versus full-width doors. This maximizes design efficiency within the data center.

Door Features:

- Doors can be mounted as either left-hand or right-hand
- Vented doors feature a 77% open airflow pattern, exceeding major OEM/equipment vendor requirements
- Swing handles with keyed locks
- Combination swing handle locks optional
- Locks can be ordered keyed alike or separately (keyed separately option quoted upon request)
- Optional solid inserts for flush doors available for when thermal requirements change and chimneys are needed

Door Features



Swing handle with lock
Secures valuable equipment



Combination handle (H907)
Optional handle with keyed lock

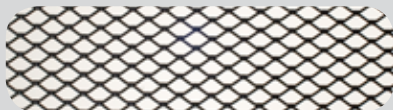

Vented pattern
77% open pattern

24" Width Flush

RU Height	Vented	Door with Solid Insert
52	DK-BFZ-52U24	DK-BFZ-SPI-52U24
48	DK-BFZ-48U24	DK-BFZ-SPI-48U24
44	DK-BFZ-44U24	DK-BFZ-SPI-44U24
42	DK-BFZ-42U24	DK-BFZ-SPI-42U24

Note: For 29" width, change "24" to "29" in part number. (i.e. DK-XXX-52U24 becomes DK-XXX-52U29)

For 32" width, change "24" to "32" in part number. (i.e. DK-XXX-52U24 becomes DK-XXX-52U32)

24" Width Curved-Face

RU Height	Vented
52	DK-ACZ-52U24
48	DK-ACZ-48U24
44	DK-ACZ-44U24
42	DK-ACZ-42U24

24" Width French-Flush

RU Height	Vented	Door with Solid Insert
52	DFK-BFZ-52U24	DFK-BFZ-SPI-52U24
48	DFK-BFZ-48U24	DFK-BFZ-SPI-48U24
44	DFK-BFZ-44U24	DFK-BFZ-SPI-44U24
42	DFK-BFZ-42U24	DFK-BFZ-SPI-42U24

Note: For 29" width, change "24" to "29" in part number. (i.e. DFK-XXX-52U24 becomes DFK-XXX-52U29)

For 32" width, change "24" to "32" in part number. (i.e. DFK-XXX-52U24 becomes DFK-XXX-52U32)



Flush Door Solid Inserts

Flush Door Solid Inserts

Titan DT vented flush doors can be expanded as thermal requirements for your racks change. Solid cover panels are available to convert front-to-rear (hot aisle) cooling to an overhead duct design. Simply add the solid cover panels over the existing screens.

Solid Insert Part Numbers

- French Door Solid Insert: SPI-DF-xxUyy
- Flush Door Solid Insert: SPI-D-xxUyy

Note: For solid insert part numbers, replace “xx” with the RU height and “yy” with the width.



Note: Used with Overhead Chimney Solution



Side Panels



Side Panels

Side panels have been designed for use as baffle panels to contain thermal loads within a rack, or as side panels to close off an existing side of a rack.

They mount within the side perimeters of the rack for a flush design aesthetic.

Side Panel Features:

- Keyed lock, keeping panels secure
- Latches provide easy on/off mechanism
- Can be mounted in place between multiple-bay consoles

Side Panel

Cable Management Side Panel with Levelers

Side Panel Features



Keyed Lock

Titan DT side panels come with a lock that keeps the side panel secure.



Side Panel Latch

Titan DT side panels include a latch system for easy installation and removal.

Side Panel

RU Height	42" Depth	45" Depth	48" Depth
52	SPK-BFS-52U-42	SPK-BFS-52U-45	SPK-BFS-52U-48
48	SPK-BFS-48U-42	SPK-BFS-48U-45	SPK-BFS-48U-48
44	SPK-BFS-44U-42	SPK-BFS-44U-45	SPK-BFS-44U-48
42	SPK-BFS-42U-42	SPK-BFS-42U-45	SPK-BFS-42U-48

Cable Management Side Panel

RU Height	42" Depth	45" Depth	48" Depth
52	TPS-52U-42	TPS-52U-45	TPS-52U-48
48	TPS-48U-42	TPS-48U-45	TPS-48U-48
44	TPS-44U-42	TPS-44U-45	TPS-44U-48
42	TPS-42U-42	TPS-42U-45	TPS-42U-48



Top Panels



Solid

Brush Strip



Cover Plate

Chimney

Top Panels

Titan DT top panels provide expanded options to address today's cooling and cabling requirements. Top panels provide an additional level of security as they are bolted directly to the top of the rack.

All top panels have two 5" x 8" brush strip covered cutouts in front.

Solid

- One-piece, solid-plate construction sits within the top of the rack

Cover Plate

- Two-piece, solid-plate construction with removable solid cover plate

Brush Strip

- One-piece construction with three removable brush strip sections

Chimney

- Chimney solutions prevent hot and cold air mixing in the cabinet. Kit includes top panel, air deflector and top exhaust duct.

Front Brush Cutouts

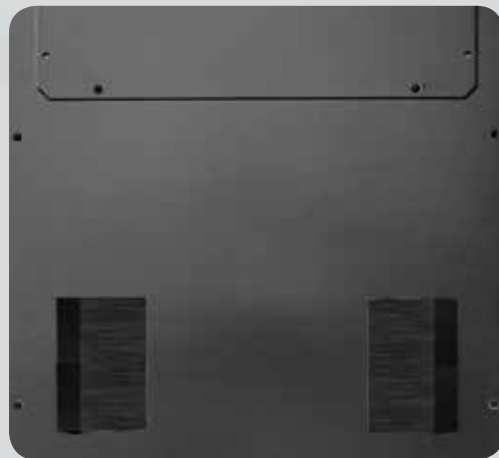

Brush Cutouts

Brush cutouts address demands of wire and cable deployment above the server rack.

Top Panels

Solid	Brush Strip	Cover Plate
TP-AFS-24-48	TP-AFB-24-48	TP-AFC-24-48
TP-AFS-24-45	TP-AFB-24-45	TP-AFC-24-45
TP-AFS-24-42	TP-AFB-24-42	TP-AFC-24-42

*Note: For 29" width, change "24" to "29" in part number.
(i.e. TP-XXX-24-45 becomes TP-XXX-29-45)*

*For 32" width, change "24" to "32" in part number.
(i.e. TP-XXX-24-45 becomes TP-XXX-32-45)*

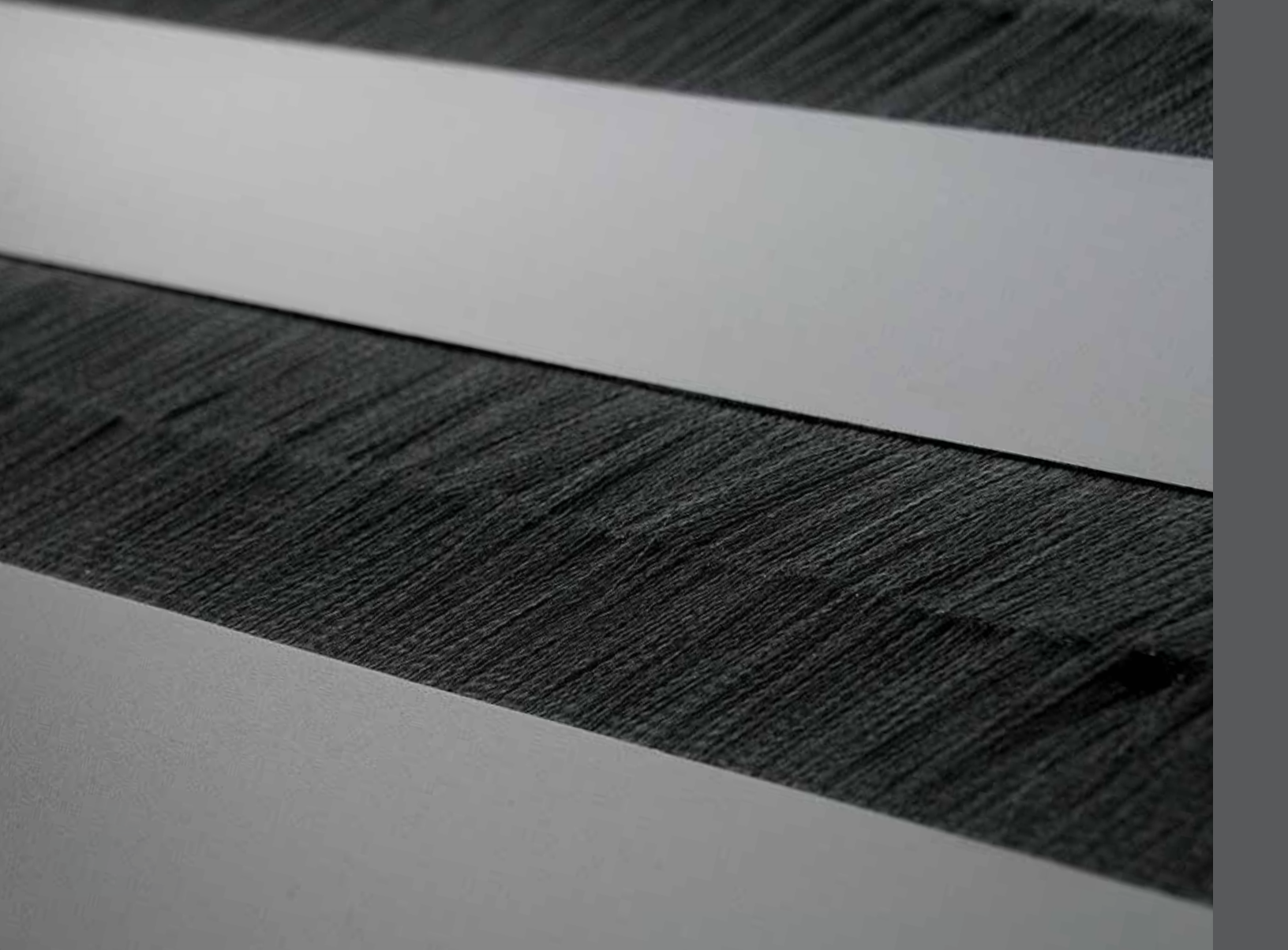

Top Panel Expansion

Titan DT top panels with cover plate can be ordered as a solid top panel to support front-to-rear cooling in racks. Or the cover plate can be removed and the chimney component added when designs call for hot air to be exhausted away from the rack to the overhead CRAC system for recirculation.

For a complete system, order the overhead chimney solution kit, which includes top panel, chimney, and air deflector.

See Overhead Chimney Solution on page **21**



Top Panel Cover Plate for front-to-rear cooling



Cover Plate removed and Overhead Chimney Solution added for overhead CRAC deployment



Mounting Channels



MCX Profile



MCW Profile Reducer

Mounting Channels

Mounting channels are fully adjustable within the rack to provide much more precise equipment adjustments.

Mounting channels feature an M6 square-hole pattern and have individually numbered RUs for each rack unit, resulting in fast and easy equipment installation.

All Titan DT mounting channels have a durable black powder coat finish.

MCX Profile Features:

- For standard 19" mounting on 24" overall rack widths (24" width frames require two pairs of MCX mounting channels per frame)

MCW Profile Reducer Features:

- Provides 19" front-mounting space in 29" or 32" overall rack width
- 1RU cutouts with plastic covers

MCW Profile Reducer Finger Channel Features:

- Provides 19" front-mounting space in 29" or 32" overall rack width
- 1RU or 2RU wire finger managers provide cable management support to individual RUs in rack
- Metal fingers have a depth of 7.25" to accommodate larger cable bundles with a usable depth of 6"
- 1RU cutouts with plastic covers
- Brush to cover cutout can be ordered separately

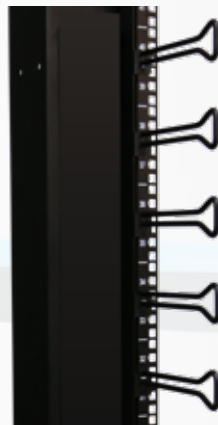
MCW Profile Reducer
1RU Finger ChannelsMCW Profile Reducer
2RU Finger Channels

Channels for 24" Width Rack

RU Height	MCX Profile
52	MCX-TN-S-52U
48	MCX-TN-S-48U
44	MCX-TN-S-44U
42	MCX-TN-S-42U

Note: MCX Profile is used for 24" wide only.

Channels for 29" Width Rack

RU Height	MCW Profile Reducer	MCW Profile Reducer 1RU Finger	MCW Profile Reducer 2RU Finger
52	MCW-TN-S-52U	MCW-TN-S-F52U-1	MCW-TN-S-F52U-2
48	MCW-TN-S-48U	MCW-TN-S-F48U-1	MCW-TN-S-F48U-2
44	MCW-TN-S-44U	MCW-TN-S-F44U-1	MCW-TN-S-F44U-2
42	MCW-TN-S-42U	MCW-TN-S-F42U-1	MCW-TN-S-F42U-2

Note: MCW Profile is used for 29" and 32" wide only.

Channels for 32" Width Rack

RU Height	MCW Profile Reducer	MCW Profile Reducer 1RU Finger	MCW Profile Reducer 2RU Finger
52	MCW-TN-S-32-52U	MCW-TN-S-32-F52U-1	MCW-TN-S-32-F52U-2
48	MCW-TN-S-32-48U	MCW-TN-S-32-F48U-1	MCW-TN-S-32-F48U-2
44	MCW-TN-S-32-44U	MCW-TN-S-32-F44U-1	MCW-TN-S-32-F44U-2
42	MCW-TN-S-32-42U	MCW-TN-S-32-F42U-1	MCW-TN-S-32-F42U-2

Note: MCW Profile is used for 29" and 32" wide only.



Mounting Channel Finger Options



1RU Finger Mounting Channel 2RU Finger Mounting Channel

1RU & 2RU Finger Channel Kit

Finger mounting channels feature metal fingers that are 7.25" with a usable depth of 6" in 1RU and 2RU designs for cable-routing requirements. 1RU finger channels have a full 1.75" from finger center to finger center as the 2RU finger channel's center-to-center open spacing is 3.50" for larger cabling requirements.

Finger Bracket and Fingers Added to Mounting Channels

RU Height	1 RU Part Number	2 RU Part Number
52	HKF-52-1U-L	HKF-52-2U-L
48	HKF-48-1U-L	HKF-48-2U-L
44	HKF-44-1U-L	HKF-44-2U-L
42	HKF-42-1U-L	HKF-42-2U-L

*Note: Mounting Channels not included.
For Finger Bracket and Fingers mounting on the right side, replace "-L" with "-R".*



Mounting Channel with Internal Cable Raceway Door

Brush Strip Kit BRSH-PP

Internal Cable Raceway Door

The Internal Cable Raceway Door conceals and protects cables inside the finger raceway.

RU Height	29" Width Part Number	32" Width Part Number
52	IFD-52U-29	IFD-52U-32
48	IFD-48U-29	IFD-48U-32
44	IFD-44U-29	IFD-44U-32
42	IFD-42U-29	IFD-42U-32

Brush Strip Kit

Brush Strip Kit for 1RU cutout mounting channels.
Note: Contains one 1U brush strip only.

Horizontal and Vertical Gap Fillers

The Horizontal and Vertical Gap Fillers provide a barrier to help prevent air leakage when the front mounting channels are recessed.

Horizontal Gap Fillers

24" Width Part Number	29" Width Part Number	32" Width Part Number
HGF-24W-10-14	HGF-29W-10-14	HGF-32W-10-14
HGF-24W-6-10	HGF-29W-6-10	HGF-32W-6-10

Vertical Gap Fillers

RU Height	Part Number
52	VGf-52U
48	VGf-48U
44	VGf-44U
42	VGf-42U

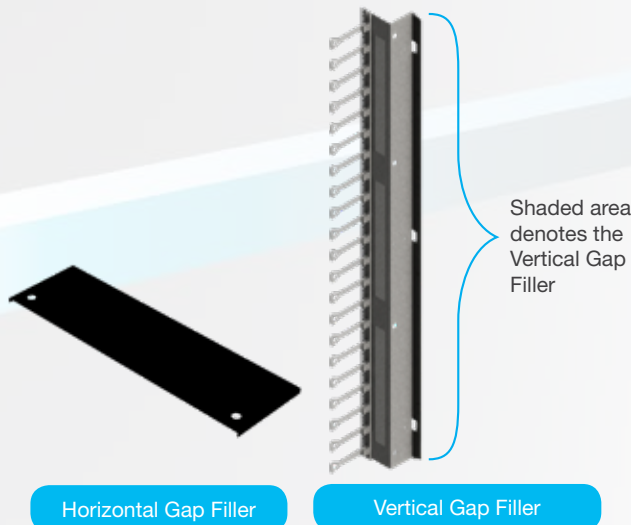

Horizontal Gap Filler

Vertical Gap Filler



Cable Management

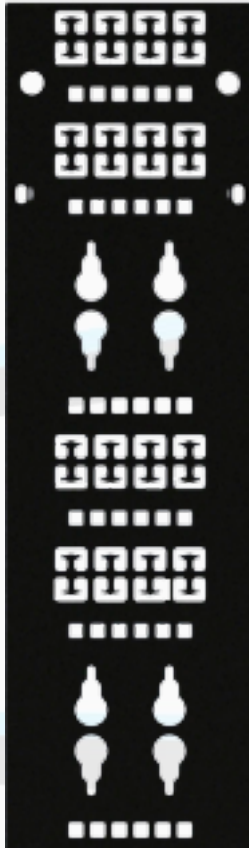

Power/Cable Panel

Power/Cable Panel

Available in four rack heights and two widths, power/cable panels mount in the rear of the rack and provide mounting support for PDUs and cable bundles. Power/cable panels have a combination of keyhole pattern slots, M6 square holes and T-bars for velcro straps.

Power/Cable Panel Features:

- Tool-less mounting makes PDU mounting fast and easy
- Frees up additional RU space in a rack as PDUs are mounted to the panel rather than in the panel opening
- Properly organized cabling and PDUs at the rear of the rack do not block hot air exhausted from the back of servers. Hot, trapped air increases back pressure and results in higher thermal loads
- Panels are an efficient cable management solution that neatly organizes your cable bundles

RU Height	5" Width	7" Width
52	PCP-52U-5	PCP-52U-7
48	PCP-48U-5	PCP-48U-7
44	PCP-44U-5	PCP-44U-7
42	PCP-42U-5	PCP-42U-7

Tool-less Power Strip Mounting

Power/Cable Panels

The power/cable panel provides tool-less keyhole mounting for PDUs, making power and cable management fast and easy.



Cable Management

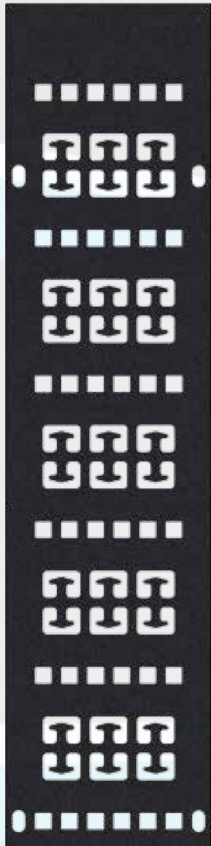

Cable Lacing Strip

Cable Lacing Strip

Available in four rack heights and a 5" width, cable lacing strips mount in the rear of the rack or between mounting channels and provide mounting support for cable bundles. Cable lacing strips have a combination of M6 holes for cable ring mounting (HK-CR1) while the slots can accept cable ties and T-bars for velcro straps.

Cable Lacing Strip Features:

- Properly organized cabling at the rear of the rack does not impede/block hot air exhausted from back of servers. Hot trapped air increases back pressure and results in higher thermal loads
- Panels are an efficient cable management solution that neatly organizes your cable bundles

RU Height	5" Width
52	CLS-52U-5
48	CLS-48U-5
44	CLS-44U-5
42	CLS-42U-5

Horizontal Cable Manager

HCM Panels have a 2RU panel height (3.50") and feature 10 ga. steel construction. Available in 4" and 7" depths.



HCM4 - 4" Depth
HCM7- 7" Depth

Cable Ring Kit



Cable Ring Kit

Cable rings easily mount to M6 holes in power/cable panels or cable lacing strips and provide an immediate tie-down point for cabling.

Sold in packs of 10.



HK-CR1



Selecting a Cable Raceway

Mix & Match Combinations

Flexible cable management design allows you to mix and match an extensive variety of cable raceway options. All raceway options are available in 6" and 8" panel widths.

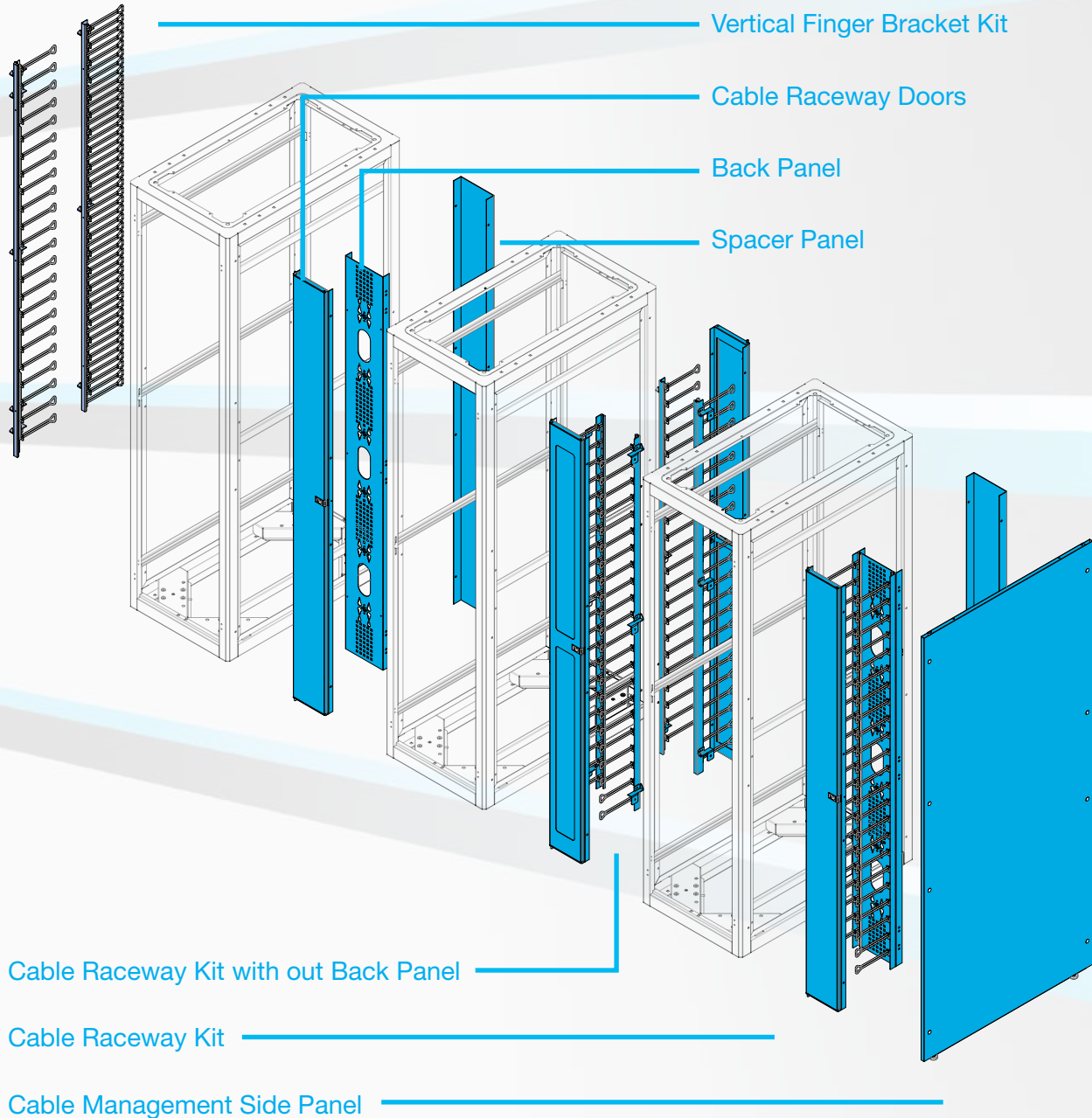

Exterior Cable Management Raceways



**CONTACT YOUR AMCO SALES REPRESENTATIVE
FOR MORE INFORMATION**



Cooling



Network Switch Cooling Solution

Network Switch Cooling Solution

Network switches typically have a large volume of cabling associated with them. AMCO has created a passive solution for switch applications that exhaust hot air out the side.

Note: Network Switch Cooling Solution includes top panel, baffle panel and vented rear door.

Note: Customer must select front raceway option of equal width to use with Network Switch Cooling Solution. Please contact your AMCO sales representative.

42" Depth

RU Height	6" Width	8" Width
52RU	NSCS-52U6-42	NSCS-52U8-42
48RU	NSCS-48U6-42	NSCS-48U8-42
44RU	NSCS-44U6-42	NSCS-44U8-42
42RU	NSCS-42U6-42	NSCS-42U8-42

Note: For 45" depth, change "42" to "45" in part number. (i.e. NSCS-52U6-42 becomes NSCS-52U6-45)

For 48" depth, change "42" to "48" in part number. (i.e. NSCS-52U6-42 becomes NSCS-52U6-48)

Tool-less Blanking Panels



Steel Blanking Panels

Steel Blanking Panels

- Tool-less
- Cover empty spaces in panel openings
- Optimize air circulation

RU Height	Steel Panel Part Number
1RU	BPT24-1U
2RU	BPT24-2U
3RU	BPT24-3U
4RU	BPT24-4U
8RU	BPT24-8U



Co-Poly Blanking Panels

Co-Poly Blanking Panels

- Ten 6 RU sheets
- Square hole only
- No tools or hardware required
- Use as complete sheet or break apart to size needed

Part Number	Color
BP-6U-P-10	Black
BP-6U-P-WHITE-10	White



Cooling



Top Duct Exhaust Kit (20" - 35")



Top Duct Exhaust Kit (35" - 60")

Overhead Chimney Solution

Isolating and containing the heat within the rack and directing it back into the overhead CRAC system is an effective passive cooling solution for high-density racks. Chimney solutions prevent hot and cold air mixing in the cabinet, as well as hot air recirculation to the front of the rack. These systems are cost-effective and efficient, reducing the cost of over-cooling your data center. Kit includes top panel, air deflector and top exhaust duct.

20" - 35" Height

24" Width
TP-AFD3-24-48
TP-AFD3-24-45
TP-AFD3-24-42

35" - 60" Height

24" Width
TP-AFD6-24-48
TP-AFD6-24-45
TP-AFD6-24-42

*Note: For 29" width, change "24" to "29" in part number.
(i.e. TP-AFD6-24-45 becomes TP-AFD6-29-45)*

*For 32" width, change "24" to "32" in part number.
(i.e. TP-AFD6-24-45 becomes TP-AFD6-32-45)*

Included with Overhead Chimney Solution:



Top Panel without Cover Plate



Air Deflector



Top Duct Exhaust
(Heights of 20" - 35" or 35" - 60")



Accessories

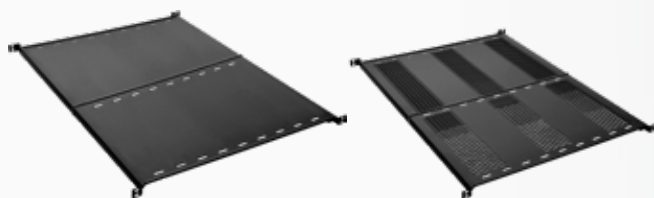

Heavy Duty Solid

Heavy Duty Vented

UA-SHAS-1725 (17" - 25")
UA-SHAS-2540 (25" - 40")

UA-SHAV-1725 (17" - 25")
UA-SHAV-2540 (25" - 40")



CHGA-TN-2536-D
(25" to 33.75" Depths)



Light Duty Caster
CA-C175

Heavy Duty Caster
CA-C1200



M6
HKM6-25

Dzus M6
HKDZ-25



Joining Kit
HK-R-TN



Busbar

BB-TN-52U
BB-TN-48U
BB-TN-44U
BB-TN-42U

Heavy Duty Shelves

Heavy duty shelves are 1.75"H (1RU), fit 19" width panel openings and have depths of 17" up to 40". They are available in solid or vented models and are load-rated to support up to 300 lbs. Shelves mount to the front and rear of the mounting channels. Standard finish is black powder coat.

Adjustable Chassis Guides

Chassis guides have a 2" H x 2" W profile and are fully adjustable from 25" thru 33.75". The flanges support component-mounted hardware in a minimal profile. Chassis guides support 125 lbs. Standard finish is black powder coat.

Casters

Casters are available in two options. Heavy duty casters are used when moving a fully integrated rack and light duty casters are used when moving empty racks into position.

- Light duty -175 lbs. load rating
 - adds 1" to overall frame height
- Heavy duty -1,200 lbs. load rating
 - adds 1.75" to overall frame height

Hardware Kits

Each rack ships with 50 ea. HK M6 inserts and screws to make mounting hardware/components easy to install. Additional mounting hardware is available for equipment mounting:

Square Hole Mounting Hardware Kits

HKM6-25 or **-50** M6 hardware for equipment mounting. Includes 25 or 50 M6 mounted screws.

HKDZ-25- (25) M6 Metric Dzus easy inserts and M6 clear chromate screws.

Frame-Joining Hardware

HK-R-TN- Frame-joining kit (8 pieces)

Ground Bar

Vertical busbars are used to ground your valuable equipment within the rack. Busbars are copper with a 1" W x 1/4" D profile. They feature #10-32 tapped holes.



Technical - Frame

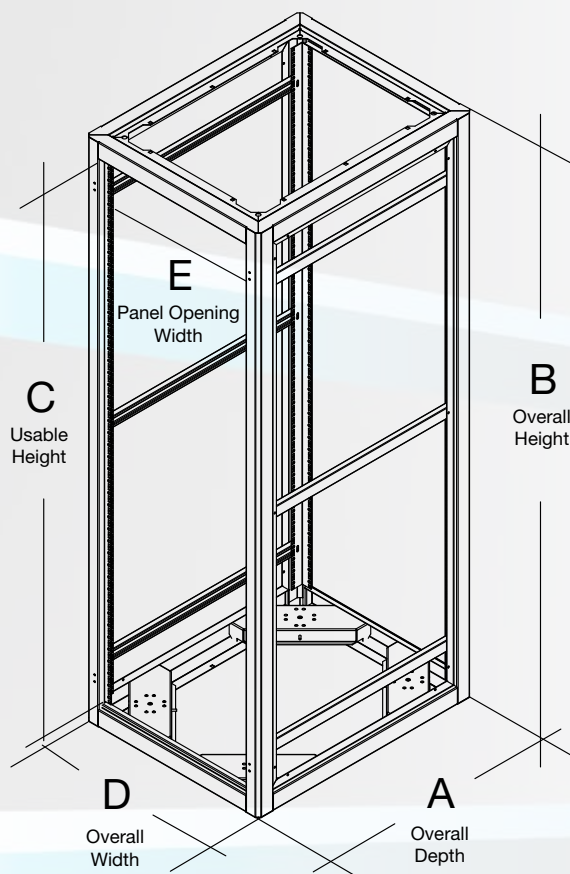

Titan DT Frame Construction

Four separate 14 ga. (.074) welded CRS main channels provide a rugged frame assembly. Vertical frame channels also provide exceptional direct floor-bearing support.

- 14 ga. (.074) CRS uni-strut channels (sides) are welded to dual return flanges.
- Formed 12 ga. (.104) CRS gussets are welded to frame base corners for added strength and also serve as caster brackets. Caster brackets provide additional protection from forklift blades that can damage racks in transportation to site deployment.
- Easy front-to-rear, full-depth equipment adjustments based on uni-strut design.
- Four weld studs are included in each frame base for grounding requirements.

Add to overall height

- Heavy duty casters - 1.75"
- Light duty casters - 1"

Certifications and Testing

- EIA 310D Equipment Mounting
- Mil Std. 810D Vibration
- ISO 9001:2015
- Certified Static Load Rating - 5,400 lbs.
- Certified Dynamic Load Rating - 3,300 lbs.

24" Width (Material: 14ga. CRS)

RU Height	42" Depth (A) (39.75" usable)	45" Depth (A) (42.75" usable)	48" Depth (A) (45.75" usable)	Overall Height (B)	Usable Height (C)	Overall Width (D)	Panel Opening Width (E)
52	R-TN-52U24-42	R-TN-52U24-45	R-TN-52U24-48	98"	89.25"	24"	19.75"
48	R-TN-48U24-42	R-TN-48U24-45	R-TN-48U24-48	91"	82.25"	24"	19.75"
44	R-TN-44U24-42	R-TN-44U24-45	R-TN-44U24-48	84"	77"	24"	19.75"
42	R-TN-42U24-42	R-TN-42U24-45	R-TN-42U24-48	80.5"	73.5"	24"	19.75"

Note: Overall height includes leg levelers (.625")

29" Width (Material: 14ga. CRS)

RU Height	42" Depth (A) (39.75" usable)	45" Depth (A) (42.75" usable)	48" Depth (A) (45.75" usable)	Overall Height (B)	Usable Height (C)	Overall Width (D)	Panel Opening Width (E)
52	R-TN-52U29-42	R-TN-52U29-45	R-TN-52U29-48	98"	89.25"	29"	24.75"
48	R-TN-48U29-42	R-TN-48U29-45	R-TN-48U29-48	91"	82.25"	29"	24.75"
44	R-TN-44U29-42	R-TN-44U29-45	R-TN-44U29-48	84"	77"	29"	24.75"
42	R-TN-42U29-42	R-TN-42U29-45	R-TN-42U29-48	80.5"	73.5"	29"	24.75"

Note: Overall height includes leg levelers (.625")

32" Width (Material: 14ga. CRS)

RU Height	42" Depth (A) (39.75" usable)	45" Depth (A) (42.75" usable)	48" Depth (A) (45.75" usable)	Overall Height (B)	Usable Height (C)	Overall Width (D)	Panel Opening Width (E)
52	R-TN-52U32-42	R-TN-52U32-45	R-TN-52U32-48	98"	89.25"	32"	27.75"
48	R-TN-48U32-42	R-TN-48U32-45	R-TN-48U32-48	91"	82.25"	32"	27.75"
44	R-TN-44U32-42	R-TN-44U32-45	R-TN-44U32-48	84"	77"	32"	27.75"
42	R-TN-42U32-42	R-TN-42U32-45	R-TN-42U32-48	80.5"	73.5"	32"	27.75"

Note: Overall height includes leg levelers (.625")



Technical - Frame

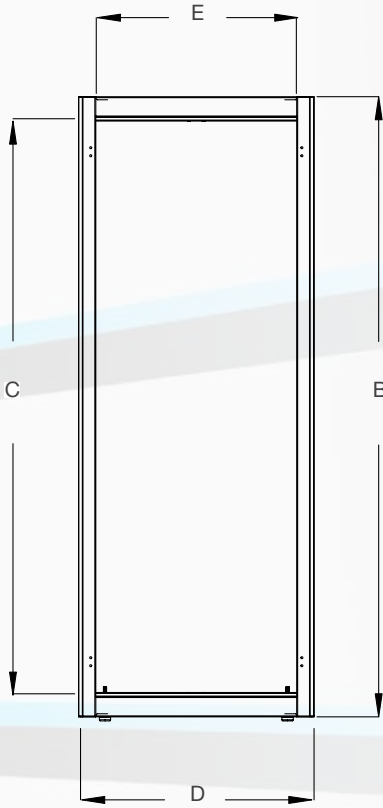

Front View

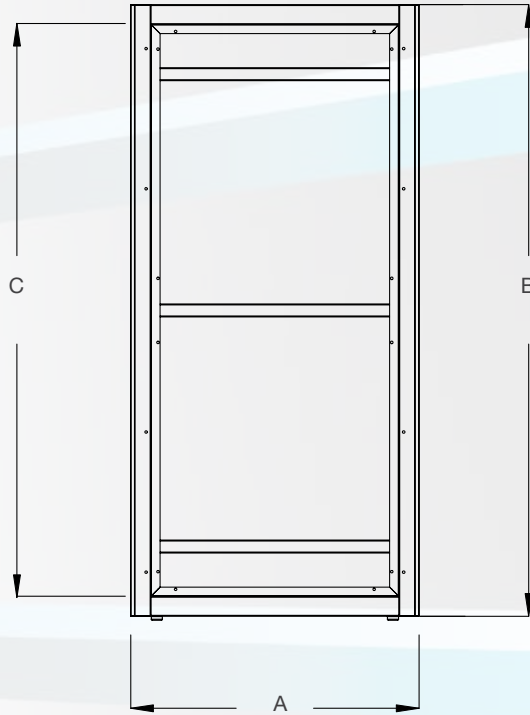

Side View

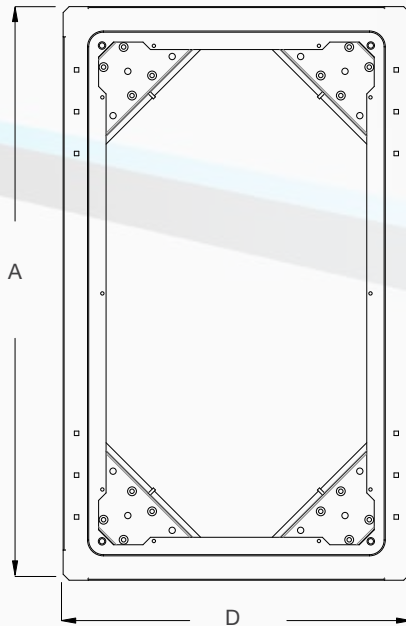

Top View

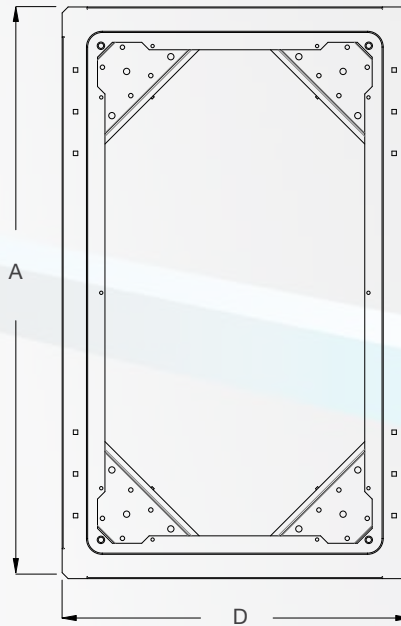

Base View



Technical - Doors

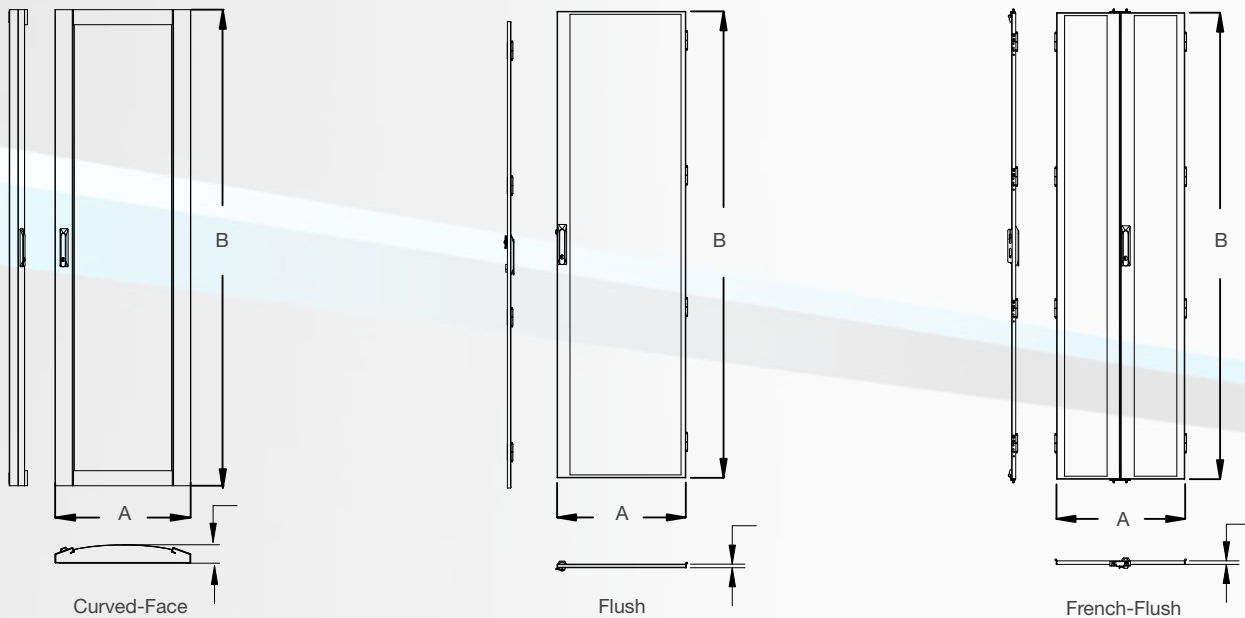

Curved-Face (Material: 18ga. CRS)

RU Height	Vented	Width (A)	Height (B)
52	DK-ACZ-52U24	22.56"	94.68"
48	DK-ACZ-48U24	22.56"	87.68"
44	DK-ACZ-44U24	22.56"	80.68"
42	DK-ACZ-42U24	22.56"	77.18"

Note: For 29" width, change "24" to "29" in part number.
(i.e. DK-ACZ-52U24 becomes DK-ACZ-52U29)

Also add 5" to width (A).

For 32" width, change "24" to "32" in part number.
(i.e. DK-ACZ-52U24 becomes DK-ACZ-52U32)

Also add 8" to width (A).

Flush (Material: 18ga. CRS)

RU Height	Solid Insert	Vented	Width (A)	Height (B)
52	DK-BFZ-SPI-52U24	DK-BFZ-52U24	19.53"	92.12"
48	DK-BFZ-SPI-48U24	DK-BFZ-48U24	19.53"	85.12"
44	DK-BFZ-SPI-44U24	DK-BFZ-44U24	19.53"	78.12"
42	DK-BFZ-SPI-42U24	DK-BFZ-42U24	19.53"	71.12"

Note: For 29" width, change "24" to "29" in part number.
(i.e. DK-BFZ-52U24 becomes DK-BFZ-52U29)

Also add 5" to width (A).

For 32" width, change "24" to "32" in part number.
(i.e. DK-BFZ-52U24 becomes DK-BFZ-52U32)

Also add 8" to width (A).

French-Flush (Material: 18ga. CRS)

RU Height	Solid Insert	Vented	Width (A)	Height (B)
52	DFK-BFZ-SPI-52U24	DFK-BFZ-52U24	19.53"	92.12"
48	DFK-BFZ-SPI-48U24	DFK-BFZ-48U24	19.53"	85.12"
44	DFK-BFZ-SPI-44U24	DFK-BFZ-44U24	19.53"	78.12"
42	DFK-BFZ-SPI-42U24	DFK-BFZ-42U24	19.53"	71.12"

Note: For 29" width, change "24" to "29" in part number.
(i.e. DFK-BFZ-52U24 becomes DFK-BFZ-52U29)

Also add 5" to width (A).

For 32" width, change "24" to "32" in part number.
(i.e. DFK-BFZ-52U24 becomes DFK-BFZ-52U32)

Also add 8" to width (A).



Technical - Side Panels

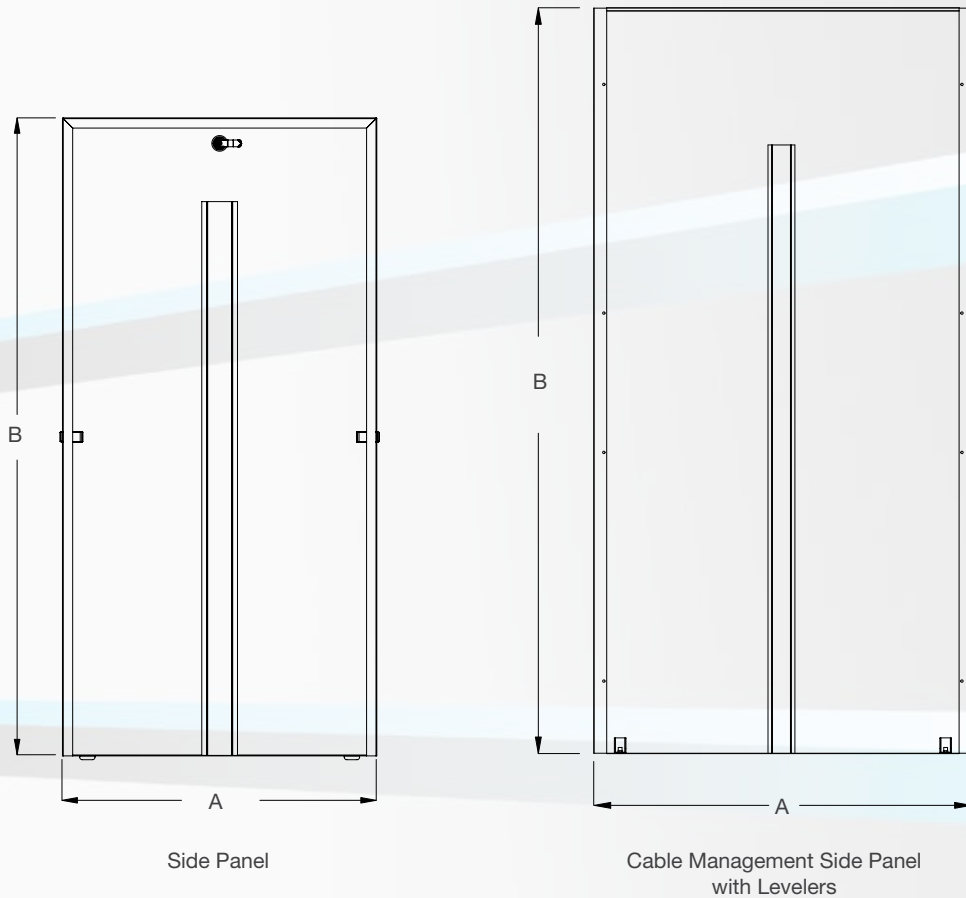

Side Panel (Material: 18ga. CRS)

RU Height	42" Depth (A 36.79")	45" Depth (A 39.79")	48" Depth (A 42.79")	Overall Height (B)
52	SPK-BFS-52U-42	SPK-BFS-52U-45	SPK-BFS-52U-48	92.25"
48	SPK-BFS-48U-42	SPK-BFS-48U-45	SPK-BFS-48U-48	85.25"
44	SPK-BFS-44U-42	SPK-BFS-44U-45	SPK-BFS-44U-48	78.25"
42	SPK-BFS-42U-42	SPK-BFS-42U-45	SPK-BFS-42U-48	74.75"

Cable Management Side Panel (Material: 18ga. CRS)

RU Height	42" Depth (A 40.79")	45" Depth (A 43.79")	48" Depth (A 46.79")	Overall Height (B)
52	TPS-52U-42	TPS-52U-45	TPS-52U-48	97.4"
48	TPS-48U-42	TPS-48U-45	TPS-48U-48	90.4"
44	TPS-44U-42	TPS-44U-45	TPS-44U-48	83.4"
42	TPS-42U-42	TPS-42U-45	TPS-42U-48	79.9"



Technical - Top Panels

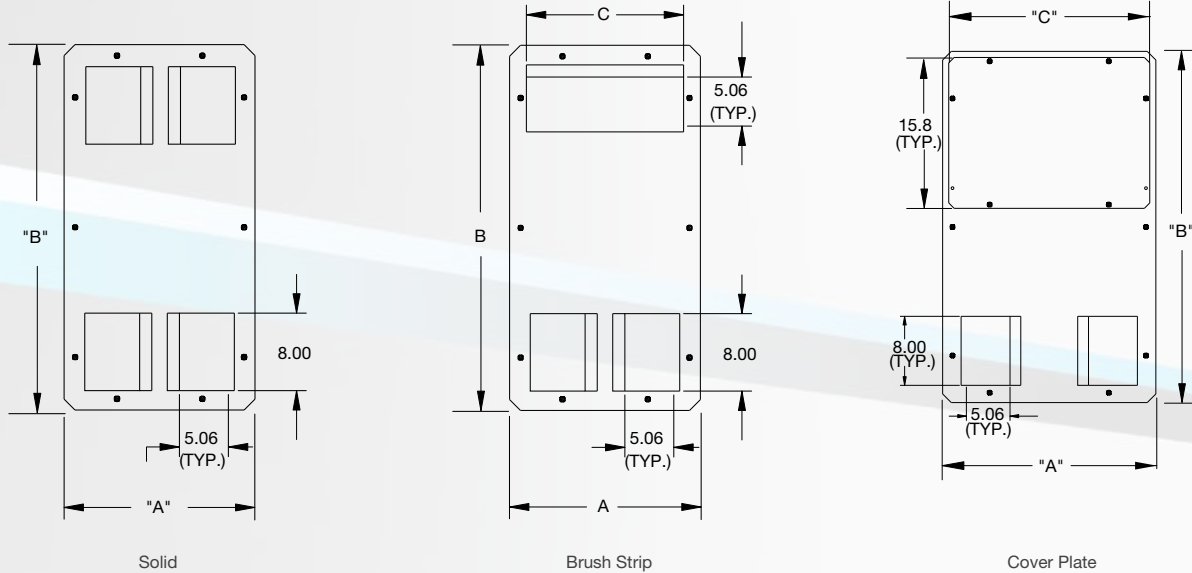

Solid Top Panel 24" Width
(Material: 16ga. CRS)

Solid	Width (A)	Depth (B)
TP-AFS-24-48	19.46"	46.46"
TP-AFS-24-45	19.46"	40.46"
TP-AFS-24-42	19.46"	37.46"

Solid Top Panel 29" Width
(Material: 16ga. CRS)

Solid	Width (A)	Depth (B)
TP-AFS-29-48	24.46"	46.46"
TP-AFS-29-45	24.46"	40.46"
TP-AFS-29-42	24.46"	37.46"

Solid Top Panel 32" Width
(Material: 16ga. CRS)

Solid	Width (A)	Depth (B)
TP-AFS-32-48	27.46"	46.46"
TP-AFS-32-45	27.46"	40.46"
TP-AFS-32-42	27.46"	37.46"

Brush Strip Top Panel 24" Width
(Material: 16ga. CRS)

Brush Strip	Width (A)	Depth (B)	Brush Strip (C)
TP-AFB-24-42	19.71"	37.71"	16.25"
TP-AFB-24-45	19.71"	40.71"	16.25"
TP-AFB-24-48	19.71"	43.71"	16.25"

Brush Strip Top Panel 29" Width
(Material: 16ga. CRS)

Brush Strip	Width (A)	Depth (B)	Brush Strip (C)
TP-AFB-29-42	24.71"	37.71"	21.25"
TP-AFB-29-45	24.71"	40.71"	21.25"
TP-AFB-29-48	24.71"	43.71"	21.25"

Brush Strip Top Panel 32" Width
(Material: 16ga. CRS)

Brush Strip	Width (A)	Depth (B)	Brush Strip (C)
TP-AFB-32-42	27.71"	37.71"	21.25"
TP-AFB-32-45	27.71"	40.71"	21.25"
TP-AFB-32-48	27.71"	43.71"	21.25"

Cover Plate Top Panel 24" Width
(Material: 16ga. CRS)

Cover Plate	Width (A)	Depth (B)	Cover Plate Width (C)
TP-AFC-24-42	19.71"	37.71"	16.55"
TP-AFC-24-45	19.71"	40.71"	16.55"
TP-AFC-24-48	19.71"	43.71"	16.55"

Cover Plate Top Panel 29" Width
(Material: 16ga. CRS)

Cover Plate	Width (A)	Depth (B)	Cover Plate Width (C)
TP-AFC-29-42	24.71"	37.71"	21.55"
TP-AFC-29-45	24.71"	40.71"	21.55"
TP-AFC-29-48	24.71"	43.71"	21.55"

Cover Plate Top Panel 32" Width
(Material: 16ga. CRS)

Cover Plate	Width (A)	Depth (B)	Cover Plate Width (C)
TP-AFC-32-42	27.71"	37.71"	21.55"
TP-AFC-32-45	27.71"	40.71"	21.55"
TP-AFC-32-48	27.71"	43.71"	21.55"



Technical - Mounting Channels



MCX Profile
(24" wide only)

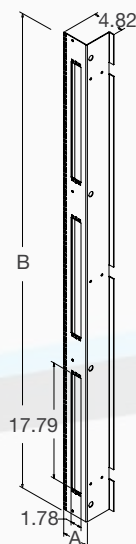

MCW Profile Reducer
(29" and 32" wide only)

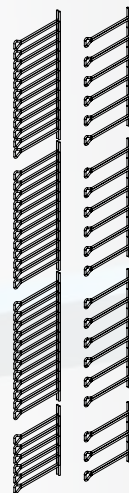

MCW Profile Reducer
1RU or 2RU Finger Channels
(29" and 32" wide only)

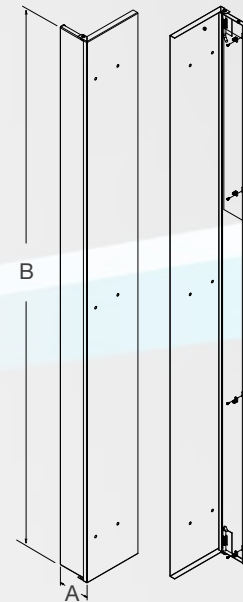
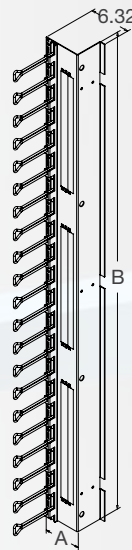

Internal Cable Raceway Door

MCX Profile (Material: 12ga. CRS)

RU Height	Part Number	Width (A)	Height (B)
52	MCX-TN-S-52U	1.56"	91.06"
48	MCX-TN-S-48U	1.56"	84.06"
44	MCX-TN-S-44U	1.56"	77.06"
42	MCX-TN-S-42U	1.56"	73.56"

Note: For 24" wide only

Internal Cable Raceway Door

Part Number	Width (A)	Height (B)
IFD-52U-29	3.12"	91.06"
IFD-48U-29	3.12"	84.06"
IFD-44U-29	3.12"	77.06"
IFD-42U-29	3.12"	73.56"

Note: For 32" wide add 1.5" to width

MCW Profile Reducer (Material: 12ga. CRS)

RU Height	Part Number	Width (A)	Height (B)	Opening Height (C)	Opening Width (D)
52	MCW-TN-S-52U	4.1"	91.06"	17.79"	1.78"
48	MCW-TN-S-48U	4.1"	84.06"	17.79"	1.78"
44	MCW-TN-S-44U	4.1"	77.06"	17.79"	1.78"
42	MCW-TN-S-42U	4.1"	73.56"	17.79"	1.78"

Note: For 29" and 32" wide only. For 32" width, add "32-" in part number after "S-". (i.e. MCW-TN-S-52U becomes MCW-TN-S-32-52U) Also add 1.5" to Width (A).

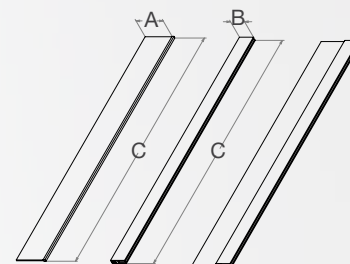

Brush Strip Kit
for 1RU cutouts Mounting Channels

MCW Profile Reducer- 1RU Fingers (Material: 12ga. CRS)

RU Height	Part Number	Width (A)	Height (B)
52	MCW-TN-S-F52U-1	4.1"	91.06"
48	MCW-TN-S-F48U-1	4.1"	84.06"
44	MCW-TN-S-F44U-1	4.1"	77.06"
42	MCW-TN-S-F42U-1	4.1"	73.56"

Note: For 29" and 32" wide only. Fingers are 7.25" with a usable depth of 6". For 2RU fingers, change "1" to "2" in part number (i.e. MCW-TN-S-F52U-1 becomes MCW-TN-S-F52U-2).

For 32" width, add "32-" in part number after "S-". (i.e. MCW-TN-S-F52U-1 becomes MCW-TN-S-32-F52U-1) Also add 1.5" to Width (A).

Brush Strip Kit for 1RU Cutouts

Part Number	Brush Width (A)	Brush Retainer Width (B)	Height (C)
BRSH-PP	1.87"	.965"	17.75"



Technical - Cable Management

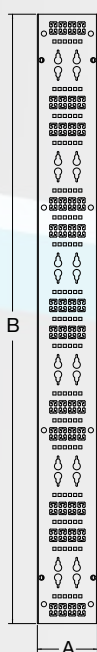

Power/Cable Panel

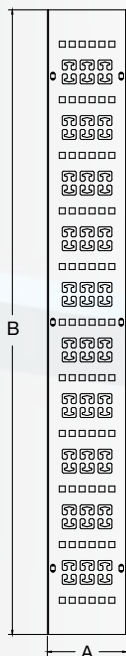

Cable Lacing Strip

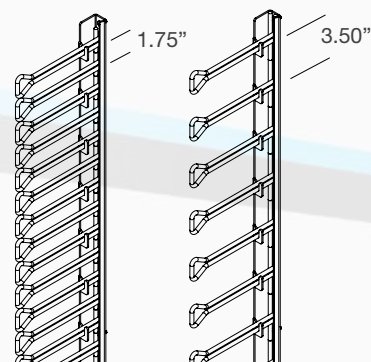

1RU & 2RU Finger Channel Kit

Power/Cable Panel (Material: 14ga. CRS)

RU Height	5" Width (A)	7" Width (A 7.25")	Height (B)
52	PCP-52U-5	PCP-52U-7	90.25"
48	PCP-48U-5	PCP-48U-7	83.25"
44	PCP-44U-5	PCP-44U-7	76.25"
42	PCP-42U-5	PCP-42U-7	72.75"

Cable Lacing Strip (Material: 14ga. CRS)

RU Height	5" Width (A)	Height (B)
52	CLS-52U-5	88.31"
48	CLS-48U-5	81.31"
44	CLS-44U-5	74.31"
42	CLS-42U-5	70.81"

Finger Bracket and Fingers Added to Mounting Channels

RU Height	1 RU Part Number	2 RU Part Number	Height (B)
52	HKF-52-1U-L	HKF-52-2U-L	91.06"
48	HKF-48-1U-L	HKF-48-2U-L	84.06"
44	HKF-44-1U-L	HKF-44-2U-L	77.06"
42	HKF-42-1U-L	HKF-42-2U-L	73.56"

Note: For Finger Bracket and Fingers mounting on the right side, replace "-L" with "-R".



Technical - Cooling

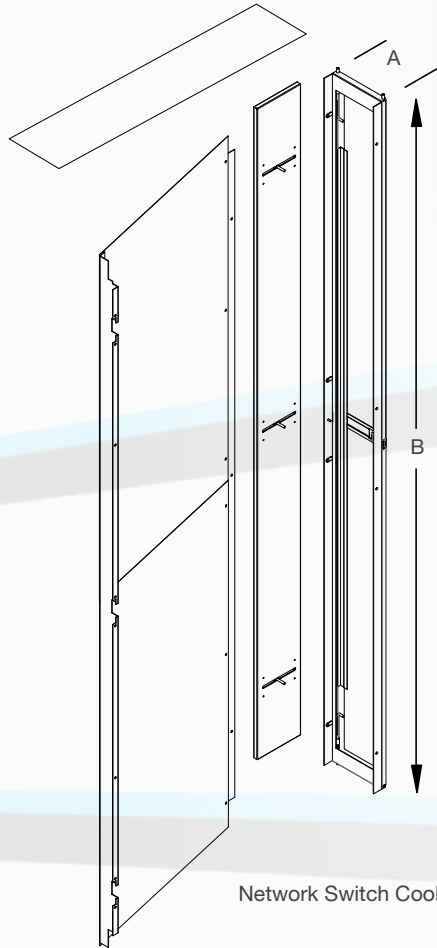

Network Switch Cooling Solution

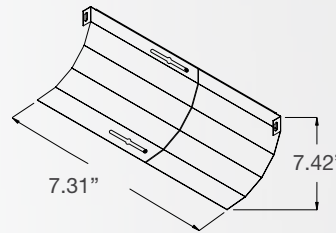

Air Deflector
Material: 18ga. CRS

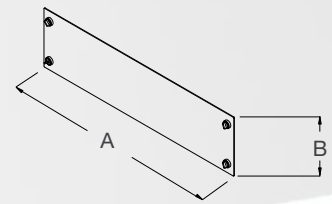

Blanking Panel
Material: 16ga. CRS

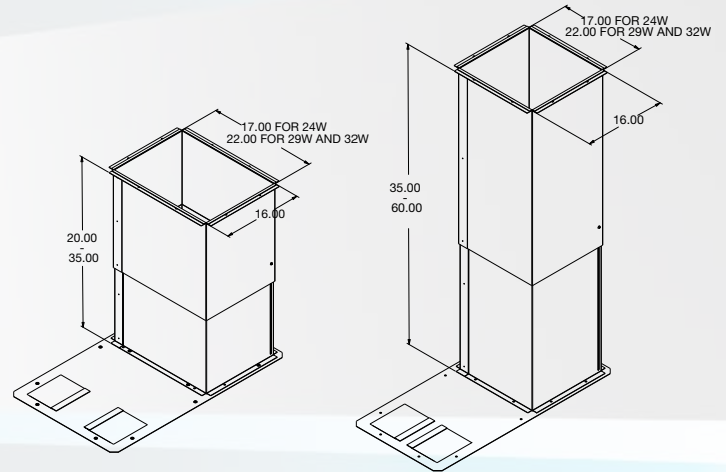

Overhead Chimney Solution
14 gauge Aluminum (.064" Thickness)

Network Switch Cooling Solution - 42" Depth

RU Height	6" Width (A)	8" Width (A)	Height (B)
52RU	NSCS-52U6-42	NSCS-52U8-42	97.37"
48RU	NSCS-48U6-42	NSCS-48U8-42	90.37"
44RU	NSCS-44U6-42	NSCS-44U8-42	83.37"
42RU	NSCS-42U6-42	NSCS-42U8-42	79.87"

Note: For 45" depth, change "42" to "45" in part number. (i.e. NSCS-52U6-42 becomes NSCS-52U6-45)
For 48" depth, change "42" to "48" in part number. (i.e. NSCS-52U6-42 becomes NSCS-52U6-48)

Blanking Panel

Part Number	Width (A)	Height (B)
BPT24-1U	19.56"	1.75"
BPT24-2U	19.56"	3.5"
BPT24-3U	19.56"	5.25"
BPT24-4U	19.56"	7"
BPT24-8U	19.56"	14"

Overhead Chimney Solution

20" - 35"

24" Width
TP-AFD3-24-48
TP-AFD3-24-45
TP-AFD3-24-42

35" - 60"

24" Width
TP-AFD6-24-48
TP-AFD6-24-45
TP-AFD6-24-42

Note: For 29" width, change "24" to "29" in part number. (i.e. TP-AFD6-24-45 becomes TP-AFD6-29-45)

For 32" width, change "24" to "32" in part number. (i.e. TP-AFD6-24-45 becomes TP-AFD6-32-45)



Technical - Accessories

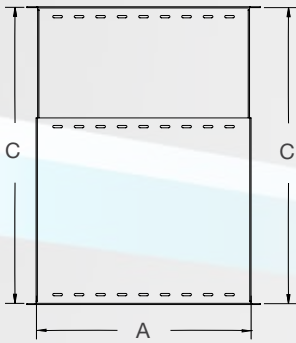

Heavy Duty Shelf - Solid

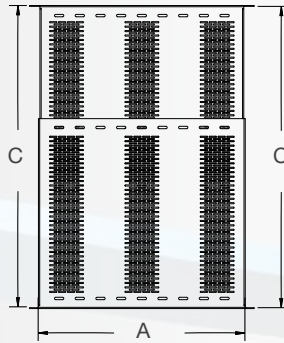

Heavy Duty Shelf - Vented

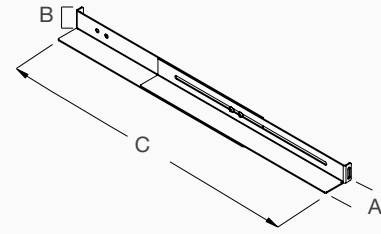

Adjustable Chassis Guides

Heavy Duty Shelves (Material: 14ga. CRS)

Solid	Vented	Width (A)	Height (B)	Depth (C)
UA-SHAS-1725	UA-SHAV-1725	19"	1.75"	17" - 25"
UA-SHAS-2540	UA-SHAV-2540	19"	1.75"	25" - 40"

Adjustable Chassis Guides (Material: 12ga. CRS)

Part Number	Width (A)	Height (B)	Depth C
CHGA-TN-2536-D	3"	1.75"	25"-33.75"



AMCO Data Center Products

Aisle Containment Solutions

AMCO's Hot Aisle and Cold Aisle Containment System prevents air mixing and establishes separation of hot exhausted air and cold supplied air. This results in efficiently cooling the equipment and not the room. With these air separation paths in place, the system can deliver a consistent inlet temperature within ASHRAE A1 recommended ranges, providing dramatic savings in capital and operational costs year after year.



AMCO Data Center Products

Titan Cable Management

AMCO's Titan Cable Management rack (TCM) is a high density, open architecture cable management system that establishes pathways for large volume network cabling. It provides complete accessibility for cabling swaps and add-ons, while providing optimal heat dissipation. This allows your network hardware to run cooler and perform as intended.

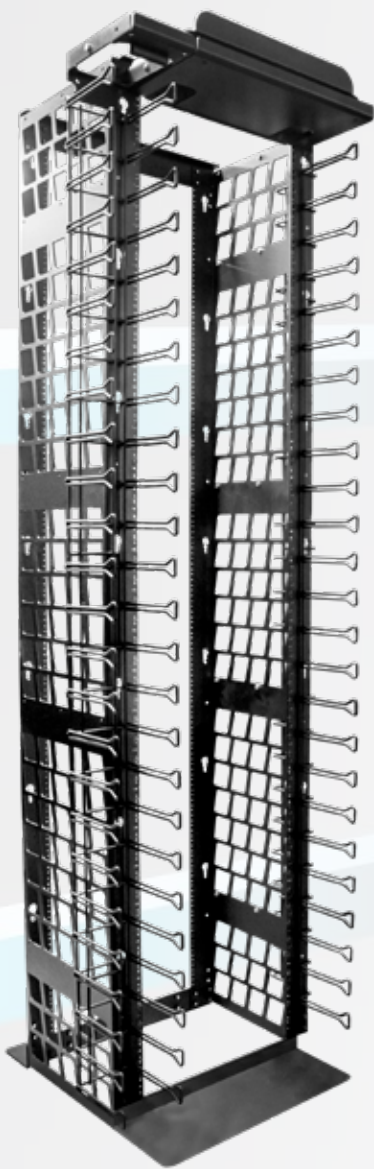

Now Available



DWM Wall Mount Cabinet

The DWM wall mount cabinet has been designed as a cost effective smaller system solution for mounting electronics equipment in secured and non-secured areas. The DWM has a load rating of 250 lbs. The DWM is 24" wide and available in depths of 17", 22", 26" and 30", with RU height options of 12, 18 and 27. The reversible front doors are smoked glass. All doors feature a keyed lock for secured access. The back panel has cutouts to accommodate electrical outlets and knockouts in the top and bottom for conduit and cabling. Two pairs of fully adjustable mounting rails are included. The DWM wall mount cabinet features a black durable powder coat finish.

Note: Unit mounts to wall as right hand hinged, left hand option is available upon request.

DWM Fan Panel Kit



Fan Panel Kit
DWM-FK-2

The fan kit includes two 115V AC fans, with a 4" diameter that deliver 60 CFM at 27db each. The fan kit also includes fan guards, a 5' power cord with ground, and mounting hardware.

Rack Units	Sections	Height	Width	Depth	Part Number	Door	Color
12RU	Single	24.38"	23.62"	17.72"	DWM-12U-600-450	Smoked Glass	Black
		24.38"	23.62"	25.60"	DWM-12U-600-650		
	back box extension	24.38"	23.62"	21.65" *	DWM-BF-12U-600-100		
		24.38"	23.62"	29.53" *	DWM-BF-12U-600-100		
18RU	Single	34.82"	23.62"	17.72"	DWM-18U-600-450		
		34.82"	23.62"	25.60"	DWM-18U-600-650		
	back box extension	34.82"	23.62"	21.65" *	DWM-BF-18U-600-100		
		34.82"	23.62"	29.53" *	DWM-BF-18U-600-100		
27RU	Single	50.50"	23.62"	17.72"	DWM-27U-600-450		
		50.50"	23.62"	25.60"	DWM-27U-600-650		
	back box extension	50.50"	23.62"	21.65" *	DWM-BF-27U-600-100		
		50.50"	23.62"	29.53" *	DWM-BF-27U-600-100		

**Note: Back box extension depth is listed as total amount when combined with single section above.*



Other AMCO Data Center Products

Titan ZN4 Seismic Rack

AMCO Enclosures' Titan ZN4 seismic racks provide a safe, secure environment for sensitive equipment in areas where earthquakes can put systems at risk without notice. AMCO's Titan ZN4 rack has been engineered, tested and certified to meet Telcordia GR-63-CORE NEBS requirements for Zone 4 seismic requirements.



Spartan

Spartan preconfigured enclosures ship completely assembled and offer a high quality, cost effective solution for mounting your IT components. With integrated cable management, split side panels and 70% perforated doors, AMCO's Spartan cabinets are a great solution for stand-alone cabinets or for large data center deployments.



Warranty & Policies

A. Choice of Method of Shipment

Unless otherwise specified, AMCO Enclosures are shipped as individual modules per ISTA packaging certification with single width components assembled on the frame. Upon request, console arrangements will be completely assembled at the factory and shipped like furniture, via van, at no additional charge for assembly. Console arrangements may also be crated for shipment. Crating charges will be quoted for each such order, as console arrangements vary.

B. Design Changes

To allow continued progress, improvement, and adaptability in an advancing industry, AMCO Enclosures reserves the right to make product changes as deemed necessary.

C. Price Discounts

Purchase orders cannot be combined for discount advantages.

D. Proprietary Rights

The catalog and drawings contain information deemed proprietary to AMCO Enclosures and are to be used only for the purposes for which they are submitted and, further, shall not be copied in whole or in part without the prior written consent of AMCO Enclosures.

E. Cancellation & Return

Cancellation and return charges begin at 40% with a minimum of \$50.00, depending on the nature of the order and the extent to which it has been processed. All returns have a 30-day, upon receipt, time limit. Returns must be freight prepaid and not made without the prior written approval of AMCO Enclosures.

F. Terms

All quotations, order confirmations, published prices, and discounts based on delivery F.O.B. AMCO Enclosures, 1 Innovation Drive, Des Plaines, IL freight collect. Invoice payment terms-net 30 days.

G. Sales Representation

Experienced factory sales representatives in all principle cities of the U.S.A., Canada and Mexico. Ask for sales representative listing. AMCO Enclosures equipment is thoroughly inspected prior to shipment. No returns of damaged equipment will be accepted without prior written approval of AMCO Enclosures.

IMS Engineered Products is

ISO9001 Certified



Designed and
Manufactured in the USA

Limited Warranty

AMCO Enclosures will repair or replace enclosures, accessories, and components manufactured by AMCO Enclosures that are proven to be defective in material or factory workmanship under normal use during the Period of this Warranty.

Warranty Period

Ten years from date of purchase. (Non-transferable)

This warranty does not cover:

- Failure in whole or part resulting from misuse, alteration, excessive temperature, excessive humidity, corrosive environment, or lack of maintenance.
- Any materials or components used or manufactured pursuant to the purchaser's specifications.
- Items ordered in error or not required.

Power/Accessories

Warranty as specified by manufacturer.

Warranty Repair

Purchaser shall obtain controlled authorization number before returning any items alleged to be defective to AMCO Enclosures.

Inspection

AMCO Enclosures shall have the right to inspect any and all allegedly defective items on-site at purchaser's convenience.

Disclaimer of Consequential Damages and Limitations of Implied Warranty

AMCO Enclosures disclaims any responsibility for loss of time or use of parts or equipment wherein AMCO Enclosures, components, or accessories are used, transportation or any other incidental or consequential damage; and any implied Warranties including the implied Warranty of merchantability and fitness for intended use are limited to the duration of this written warranty.

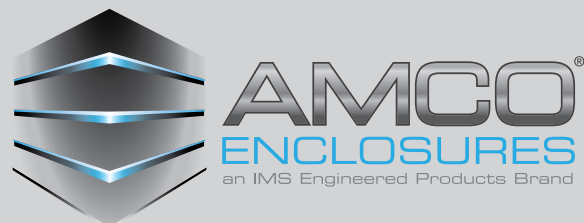

1 Innovation Drive
Des Plaines, IL 60016
www.amcoenclosures.com
847-391-8100