

An Introduction to Fluoroscopy Safety

Charles M. Anderson MD, PhD

Edwin M. Leidholdt, Jr. PhD

Introduction

Many physicians assume fluoroscopy is inherently safe technology. Yet each year several patients in the U.S. suffer permanent skin damage from fluoroscopic procedures, requiring surgical correction. In addition, radiation has the potential to induce cancer. This manual describes the techniques one can use to reduce fluoroscopic radiation dose to patients, while maintaining acceptable image quality.

If you intend to operate a fluoroscope, we suggest you read this manual, and then:

- ✚ Ask someone to demonstrate the controls of the equipment you will be using.
- ✚ Have an experienced operator observe your first cases.
- ✚ Participate in a QA program, with the goal of minimizing dose without impairing clinical outcome.

Ensure that the equipment you are using has been inspected by a medical physicist according to State or Federal regulations, and that the room shielding has been similarly tested.

Acknowledgements

This manual is based on a Department of Veterans Affairs course developed by Drs. Anderson and Leidholdt. We thank Fred A. Mettler Jr., MD, MPH and Donald P. Frush, MD FACR, FAAP for reviewing the manuscript.

Disclaimer

The Department of Veterans Affairs is not responsible for the contents of this manual.

Even if one employs dose sparing techniques as described in this manual, a patient could be injured.

Some of the techniques described here are vendor and model specific. Your equipment may operate differently. Consult the operating manual or your vendor's technical representative.

Version: August 19, 2013

Table of Contents

Page	Chapter
2	Introduction
4	Measuring Dose
9	Biological Effects of Radiation
16	Fluoroscope Technology and Image Quality
27	Minimizing Dose to the Patient
31	Pediatric Fluoroscopy
33	Minimizing Dose to the Practitioner
39	Resources

Measuring Dose

A discussion of fluoroscope settings and their effect on x-ray dose will be more meaningful once we have defined x-ray dose and explained how it is measured.

Motivation for Measuring Radiation Dose

There are practical reasons why you should understand dose units and take note of the radiation dose of each procedure you perform.

- ✚ If you know the typical dose metrics for procedures you perform, you can conduct an appropriate risk/benefit conversation with your patients before the procedure begins.
- ✚ If you keep track of how much dose your patients have received during a procedure, you can determine when the benefits of continuing no longer exceed the risks.
- ✚ If you note the measurements of dose at the end of a procedure, you can plan for follow-up care if necessary.
- ✚ If you compare the dose metrics of your procedures to those of similar procedures that your colleagues or other practices have performed, you can improve your dose sparing techniques.

Quantities and Units

Absorbed dose

The absorbed dose is the amount of radiation energy absorbed by tissue per mass of tissue. Skin typically receives the highest absorbed dose.

Peak Skin Dose

The peak skin dose is the absorbed dose at the skin location that has received the highest dose. This quantity is used to predict a skin injury.

Entrance and Exit Skin Dose

X-rays are progressively absorbed as they pass through the body. For every 4 cm of tissue, the beam strength is reduced by about one-half. As a result, the dose received where the beam enters the body is much higher than the dose where it exits. For a typical adult abdomen, and depending on the energy of the x-ray beam, the entrance dose can be about 100 times greater than the exit dose.¹

Effective Dose

Effective dose is an approximate measure of potential harm from cancer. A procedure directed at the chest may be more likely to induce cancer than a procedure directed at an extremity, because lungs are more susceptible to cancer than is muscle. Effective dose takes these differences in cancer risk into account so that procedures can be compared in terms of their cancer potential.

¹ Wagner LK and Archer BR (2004). Minimizing risks from fluoroscopic x-rays. The Woodlands, TX: R.M. Partnerships.

Gray

Fluoroscopes display dose in units of gray (Gy). A gray is the amount of radiation energy deposition equal to one joule absorbed per kilogram of tissue. The Gy replaces the traditional unit of rad, whereby 1 Gy equals 100 rad.

Sievert

The sievert (Sv) is similar to Gy but takes into account the potential ability of the radiation to cause a biological effect, primarily cancer. The Sv replaces the traditional unit of rem, whereby 1 Sv equals 100 rem. The rem is still used in occupational health.

Absorbed skin dose is measured in Gy. Effective dose is measured in Sv. Personal dosimetry badges often report effective dose in units of mrem.

Typical Doses

Mettler et. al.² have published typical procedure effective doses for adults, which is the main source for the table below. The effective dose of a simple fluoroscopic exam is more than 100 times greater than that of a chest x-ray, while the effective dose of a complex fluoroscopically guided intervention can be thousands of times greater than that of a chest x-ray.

Procedure	Effective Dose (mSv)
Bone densitometry (DXA)	0.001
Dental Intraoral X-ray	0.005
PA Chest X-ray	0.02
Mammogram 4-views	0.4
Abdomen X-ray	0.7
Barium Swallow	6
Barium Enema	8
CT Head, each series	2
CT Abdomen, each series	8
PET/CT (F-18 FDG)	14
Endoscopic Retrograde Cholangiopancreatography	4
Coronary Angiography	2-16
Coronary Angioplasty or Radiofrequency Ablation	7-57
Transjugular Intrahepatic Portosystemic Shunt Placement	20-180

Dose Estimation

Skin dose can be estimated by a variety of means, with varying accuracy. One can place dosimeters directly on the patient's skin, one can use the dose estimate provided by the fluoroscope, or one can note how long the beam is on. One can further refine these estimates by taking into account how the dose was distributed over various skin sites.

² Mettler, FA Jr, Huda, W, Yoshizumi, TT, Mahesh, M, Effective doses in radiology and diagnostic nuclear medicine: A catalog, Radiology 2008;248:254-263.

Direct Measurement

Several types of skin dosimeters are available to measure entrance dose directly. Some measure dose in real time and can trigger an alarm when dose thresholds have been exceeded. Others can only be read at the end of the procedure. Depending on where the dosimeter is placed, it may or may not measure the actual peak skin dose. Dosimeters are the most accurate measurement tool, but they are cumbersome and not necessary for most fluoroscopic procedures.

Estimation by the Fluoroscope

Based on the fluoroscope settings and beam-on time, the instrument itself provides an estimate of dose. Because the fluoroscope does not know the actual position of the patient, the dose is not always accurate. To understand how the instrument makes this estimation one must understand the inverse square law.

Inverse Square Law

As a radiation beam emerges from the x-ray tube it diverges, covering a wider area with increasing distance from the tube, but with decreasing beam strength.

In the illustration below on the left, x-rays are directed upwards from the source. At position “A” the width of the beam is, for example, 10 cm, the area of the beam is 100 cm², and the dose rate is 30 mGy/min. At “B” which is twice the distance from the source, the width of the beam is 20 cm, the area is 400 cm² and the dose rate is 7.5 mGy/min. At B the area is four times larger than at A, and the dose rate is reduced to one-fourth. The dose rate is proportional to the inverse of the square of the distance from the source.

In the graph on the right the dose rate in this example is calculated out to a distance of 100 cm from the source. Note how dramatically the dose rate rises as one approaches the x-ray tube.

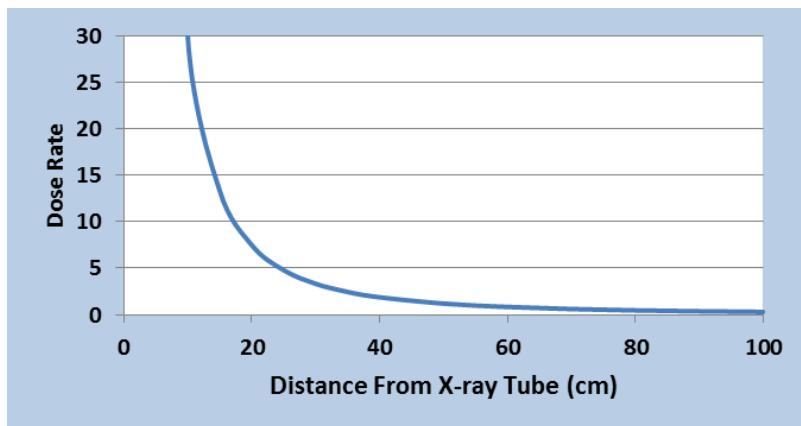
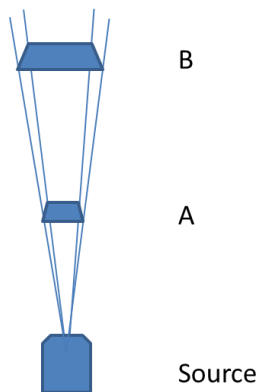

Interventional Reference Point

Because of the inverse square law, the fluoroscope must know the distance from the x-ray source to the patient’s skin in order to estimate the dose rate. The fluoroscope assumes the entrance skin is at the “reference point,” also called the interventional reference point (IRP) which for cardiac and interventional fluoroscopes is commonly 15 cm from the isocenter to the source. The isocenter is on

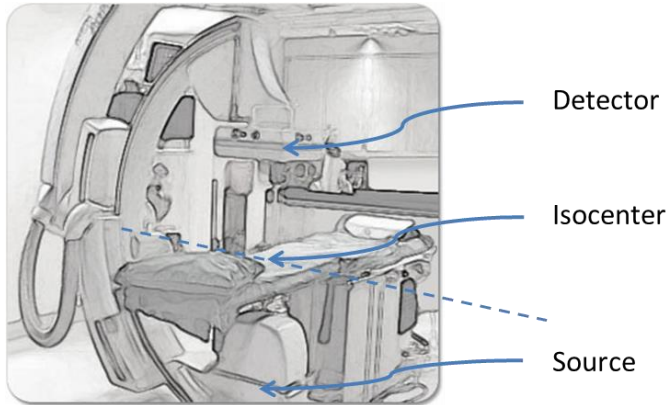

the axis of rotation of the “C-arm” that holds the x-ray source and detector, which is typically close to the center of the patient.

The axis of rotation of the C-arm is depicted as a dashed line in the illustration to the left. The isocenter lies on the rotational axis, between the source and detector.

In the illustration on the left below, the patient chest cross-section is represented by the light blue ellipse. The isocenter is at the tail of the white arrow and the IRP is 15 cm closer to the x-ray source at the head of the arrow. In this example the IRP is exactly at the skin. In the illustration on the right, the estimated entrance skin location is erroneous for an obese patient. If the patient is obese or if the source is moved closer to the patient, the skin dose will be underestimated.

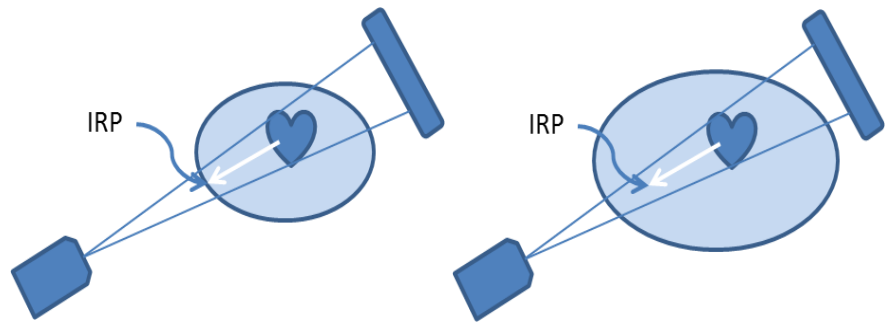

Air Kerma

The dose quantities that are calculated by the fluoroscope are the “air kerma” and the “kerma area product.”

Air kerma is the amount of energy per unit mass absorbed by air at the assumed location of the skin, usually expressed in mGy. Other names for air kerma are “reference air kerma” and “air kerma at the reference point.” The cumulative air kerma is displayed by the fluoroscope during the procedure. However one should keep in mind that it is not quite the skin dose. Air kerma may differ from skin dose for many reasons, including these three major factors:

- ✚ The skin may be closer or farther from the x-ray source than is the reference point.
- ✚ Cumulative air kerma sums the dose for the entire procedure as if the fluoroscope was stationary and directed at a single skin field, when in fact most procedures involve tilting or translating the C-arm to various positions and splitting the dose among several skin fields.
- ✚ Air kerma does not account for radiation scattered within the patient, some of which is absorbed by the skin.

Kerma Area Product

The kerma area product (KAP) is a measure of dose integrated across the entire exposed field. KAP is sometimes called dose area product (DAP). It is usually expressed in mGy cm^2 . Because vendors may use alternative names on their fluoroscope dose record, one should consult the vendor if there is any

ambiguity as to what parameter is displayed. An example of a fluoroscopic dose display is shown on the right.

Air kerma and kerma area product are both useful parameters. Air kerma is an expression of radiation at a point, so it would best predict skin injury. Kerma area product is an expression of total energy deposition across the entire exposed skin so it would best predict risk of radiation induced cancer. One should try to reduce both of these parameters when improving fluoroscopy technique.

Exp fr/s	30
Fluo	Normal
Time	19:29
AK mGy	1484.90
DAP mGy cm^2	184522

Response to a High Air Kerma

Occasionally an alarmingly high air kerma is noted after a prolonged interventional procedure. Because the air kerma may overestimate (or underestimate) the actual peak skin dose, one may be uncertain as to the actual dose the patient received. A practical and acceptable response is to notify the patient that he or she may have received a high dose and that you will be examining the skin periodically to look for injury. In that case the patient's skin becomes the most clinically relevant "dosimeter."

However there may be value in asking an expert to review the dose information. A detailed dose record is saved in the machine, or in a "radiation dose structured report" file. A medical physicist may be able to examine this data and determine what operations resulted in the unusual dose. For example the operator may have selected a high dose mode without knowing it. Modes of fluoroscope operation will be discussed later.

Estimating Dose from Beam-on Time

A traditional means of measuring dose is to note the length of time that the x-ray beam was on. Some publications provide charts relating beam-on time to dose for various procedures. Note that the beam-on time does not take into account the size of the patient, nor does it include dose from recorded images, which we discuss later. This method is relatively inaccurate and of little value.

Key Points

Key points to remember from this chapter are:

- ✚ The fluoroscope will display the cumulative "air kerma" during the procedure, expressed in units of gray (or milligray).
- ✚ Air kerma is a rough estimate of total skin dose at the beam entry site, but it assumes the fluoroscope was stationary and directed at one skin field during the entire procedure. It will overestimate the peak skin dose if the dose was distributed over multiple skin sites. It may underestimate peak skin dose if the patient was close to the x-ray tube, as for example if the patient was obese, or if the patient was improperly positioned.
- ✚ The kerma area product is a good measure of the total amount of radiation energy delivered to the patient. Try to minimize this number when performing procedures, even for those procedures that are well below the skin injury range.

Biological Effects of Radiation

The signature patient injury of fluoroscopy is radiation dermatitis, commonly called a “skin burn.” A second important but less recognized injury is radiation induced cancer.

Stochastic and Deterministic Effects

Biological effects of radiation are categorized as being stochastic or deterministic.

Stochastic Effects

Stochastic effects happen by chance. They are more likely to happen as dose increases. They don’t occur in degrees, rather they are present or not. Cancer and heritable changes in reproductive cells are examples of stochastic effects. When estimating the likelihood of a stochastic injury, one must consider the lifetime dose a patient has received.

Deterministic Effects

The severity of deterministic effects depends on radiation dose. They can be mild or severe, and if mild may resolve with time. Often there is a dose threshold above which the injury becomes detectable. Radiation dermatitis is an example. When predicting a deterministic injury, recent radiation exposure is more important than exposure months or years in the past.

Skin Effects

Skin injuries from fluoroscopic radiation range in severity from transient erythema to tissue necrosis. Transient erythema is very common following prolonged interventional procedures. Necrosis requiring debridement and skin graft occurs perhaps tens of times per year in the U.S., but an exact statistic is not available as these complications are not routinely reported to the FDA or to The Joint Commission.

In reviewing the relationship between dose and severity of injury, keep in mind that there are several stages or waves of injury.

- ✚ An immediate transient erythema may develop within hours.
- ✚ A second delayed phase of erythema may develop in about two weeks. It may resolve or heal with a scar.
- ✚ Necrosis may develop months or up to two years later, and after erythema has resolved.

Balter et. al.³ have written a comprehensive review article on radiation skin effects from which this discussion is drawn. In their article they define ranges of peak skin dose.

³ Balter S, Hopewell JW, Miller DL, Wagner LK, Zelefsky MJ. Fluoroscopically guided interventional procedures: A review of radiation effects on patients’ skin and hair. *Radiology* 2010;254:326-341.

Skin Injury as a Function of Peak Absorbed Dose

0-2 Gy Range

No observable effects should occur in most patients.

2-5 Gy Range

Doses in this range may result in mild transient erythema appearing within 24 hours and fading by 48 hours. There may also be temporary epilation from exposed skin beginning in about 3 weeks with regrowth in 8 to 12 weeks.

Recommended follow-up: Advise the patient that erythema may be observed, but should fade with time. Tell them where to expect the erythema. The patient should call you if skin changes cause discomfort, or if erythema doesn't fade. If erythema doesn't fade, the patient may have received a greater injury than predicted, and you will need to extend the monitoring period.

5-10 Gy Range

In addition to the early transient erythema described for the 2-5 Gy range, these patients may experience a second phase of erythema beginning about 10 days after the procedure. This phase may be prolonged over weeks. There may be pruritus and partial or permanent epilation.

Recommended follow-up: Tell the patient that skin effects might occur. You should arrange for the patient to be examined between 4 and 8 weeks post-procedure. If you find erythema or other effects such as desquamation, you must plan for long term monitoring to ensure the lesion resolves and does not progress to necrosis. Treat the patient conservatively. There is no point in performing a skin biopsy.

10-15 Gy Range

Early appearance may be similar to the 5-10 Gy range, with dry or moist desquamation within 4 to 8 weeks and permanent epilation, skin telangiectasia and atrophy. The lesion may be painful.

Recommended follow-up: As for the 5-10 Gy range patient, arrange for a 4 to 8 week examination. If effects such as desquamation occur, plan for long term monitoring. If a lesion develops it may persist or progress over many weeks or months. Prophylactic treatment for infection and monitoring of wound progression may be required. Skin biopsies should be avoided as they can lead to skin breakdown.

Greater than 15 Gy Range

A lesion found at 4 to 8 weeks may partially resolve only to undergo a delayed phase necrosis months later resulting from vascular damage. The most significant effect in these patients is ischemia of the skin with persistent ulceration and infection.

Recommended follow-up: Plan for long term monitoring of these patients, as the full extent of the injury may not be known for a year or more after the procedure. Injuries may require full-thickness grafting. Again, a skin biopsy is not necessary in these patients and will likely do more harm than good.

Example 1

The photograph below shows erythema resulting from multiple and prolonged cardiac electrophysiological and ablation procedures.⁴ The wound on the right back healed into a scar while the injury on the arm ultimately required grafting. The arm was too close to the x-ray source.



Example 2

A second example of an arm injury, in which the arm was accidentally positioned near the x-ray tube during a 10-hour cardiac ablation procedure.⁵ The estimated skin dose was 15-20Gy.

Note that an arm lying near the source may not be visible beneath drapes.



Example 3

The photograph that follows on the left depicts a skin injury 6 to 8 weeks following both a coronary angioplasty and a second coronary angiography procedure that was necessitated by complications.⁶ The lesion was described as having the appearance of a second degree burn. The middle photo was taken approximately 16 to 21 weeks following the procedures. Erythema had resolved but a small ulcer was present near the center of the exposed field. At 18 to 21 months (right) this ulcer had progressed to encompass most of the exposed field. This example illustrates the importance of long term monitoring.

⁴ Vlietstra RE, Wagner LK, Koenig T et al. Radiation burns as a severe complication of fluoroscopically guided cardiological interventions. *J Interv Cardiol* 2004; 17(3):131-42. Accessed from Wikimedia Commons.

⁵ Wong L and Rehm J. Radiation Injury from a Fluoroscopic Procedure. *NEJM* 2004;350(25);e23.

⁶ Shope TB. Radiation-induced Skin Injuries from Fluoroscopy. Accessed from FDA website July 2013.



Factors that Affect Outcome

The severity of skin injury may differ among patients for a number of reasons.

- ✚ The air kerma noted at the end of a procedure may not be the actual peak skin dose. The air kerma may overestimate the peak skin dose if the patient was irradiated from several different orientations, exposing non-overlapping skin fields. The air kerma may underestimate the peak skin dose if the patient is obese or if the x-ray tube was positioned too close to the patient.
- ✚ Some patients are more susceptible to radiation injury, including diabetics, those with some autoimmune disorders, DNA repair disorders, and connective tissue disorders.
- ✚ Medications, mostly those used in chemotherapy, may enhance the injury.
- ✚ Previous large doses of radiation to the same skin field lower the threshold for injury, particularly if that radiation occurred within the past few days, or if it resulted in a prior skin injury.

Skin Repair

Following a fluoroscopic procedure, DNA repair is believed to be complete with 24 hours. Repopulation of skin stem cells occurs over weeks.⁷ Stem cells can migrate into a small exposed skin field more quickly than into a large exposed field. Skin exposed to a low dose recovers more quickly and completely than if exposed to a high dose.

Because of the repair process, the injury from two fluoroscopic procedures on the same skin site is more likely to be additive if the studies were separated by days rather than by months. Before performing a fluoroscopically guided procedure, know what other high dose imaging procedures or radiation therapy the patient has undergone in the past, particularly in the past few days, and whether the patient has had a prior radiation skin injury.

⁷ Balter S, Hopewell JW, Miller DL, Wagner LK, Zelefsky MJ. Fluoroscopically guided interventional procedures: A review of radiation effects on patients' skin and hair. *Radiology* 2010;254:326-341.

Carcinogenesis

Based on epidemiological studies of atomic bomb survivors and other populations, the National Research Council estimates that each 10 mSv of effective dose to a working age adult increases the chance of developing a fatal cancer by a factor of 1 in 2000.⁸ Identifying these cancers is a challenge because cancer is so common. Until the causal relationship between low radiation dose and cancer risk is better understood, it is prudent to minimize radiation to patients from all x-ray procedures.

Latent Period

There is a delay between the time of exposure and the appearance of cancer. The latent period for solid

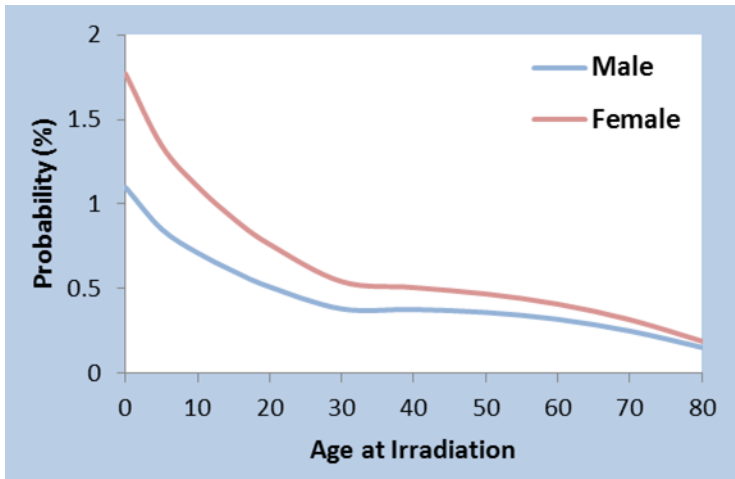

tumors may be 20 years or more, while leukemia may develop within 3 years. The graph to the left shows the lifetime radiation induced cancer mortality risk following a 0.1 Gy irradiation to the whole body.⁹ Exposure to children is more likely to cause cancer than exposure to adults because children live long enough to develop cancer. Girls are more susceptible to cancer than are boys largely because of breast cancer.

Sensitivity of Specific Organs and Tissues

When calculating effective dose, tissue specific weighting factors are applied to account for the difference in cancer susceptibility and detriment if cancer develops. According to the table below,¹⁰ radiation to bone marrow is more likely to result in cancer death than is radiation to skin.

Tissue Type	Weighting Factor
Bone marrow, colon, lung, stomach, breast, other tissues	0.12
Gonads	0.08
Bladder, esophagus, liver, thyroid	0.04
Bone cortex, brain, salivary gland, skin	0.01

Heritable Effects

Heritable effects are radiation induced mutations of sperm or ova that can be passed on to future generations. While these effects have been proven in insects and rodents, they have never been demonstrated in humans. It is nevertheless good practice to shield the gonads of patients with

⁸ National Academy of Sciences. Health risks from exposure to low levels of ionizing radiation: BEIR VII Phase 2. (2006) Washington DC: The National Academies Press.

⁹ BEIR VII Phase 2, Table 12D-2.

¹⁰ The 2007 Recommendations of the International Commission on Radiological Protection. Ann ICRP 2007;37:2-4.

reproductive potential, when the gonads are in or near the beam, and when this does not interfere with the procedure.

Fetal Teratogenesis

X-ray irradiation to a developing embryo or fetus can lead to malformations and developmental defects in the child.¹¹ When interpreting the table below,¹² keep in mind that fetal dose will be lower than the mother's skin dose.

Dose to Fetus (mGy)	Effect
Less than 100	No increased incidence of malformation, fetal demise, CNS injury or growth restriction.
100-200	Very low risk of malformation
200-500	Teratogenic effects vary with phase of pregnancy. If exposed between 8 and 15 weeks there may be measureable reduction in IQ.
Greater than 500	Significant risk of growth retardation, malformation, and CNS damage, especially if during the 3 rd to 16 th week of pregnancy.

Cataracts

Practitioners who perform interventional procedures often have opacities in their posterior lenses, thought to be an early form of cataract. A recent study of interventional cardiologists found lesions in 50 percent of practitioners.¹³ It is not known whether these microlesions will develop into symptomatic cataracts. It is also not clear whether there is a threshold of dose below which cataracts do not form. While waiting for more definitive information, it is prudent to use eye protection.

The eyes of the patient should be protected as well. If the eyes must be in the field of view, orient the beam so that it enters the head on the side opposite to the eyes.

Key Points

In applying this lesson to your practice, keep in mind that:

- ✚ Most brief fluoroscopic procedures such as swallowing and upper GI studies, facet blocks, and fracture reductions fall well below the 3 Gy skin dose level. You should not normally expect skin injuries. You should nevertheless be aware of the air kerma and kerma area product recorded during these studies, and employ techniques that reduce dose. This is especially true when imaging patients under 30 years of age, who have an elevated risk of radiation induced cancer.
- ✚ When undertaking complex interventions, inquire as to whether the patient has had a prior fluoroscopic study or radiation therapy, and whether he or she has ever had a radiation skin

¹¹ Brent RL et. al. Preconception and prenatal radiation exposure: health effects and protective guidance. NCRP Report No. 174, May 24, 2013.

¹² ACR Practice Guideline for imaging pregnant or potentially pregnant adolescents and women with ionizing radiation. 2008. www.acr.org

¹³ Ciraj-Bjelac O, Rehani MM, Sim KH, Liew HB, Vano E, Kleiman NJ. Risk for radiation induced cataract in staff in interventional cardiology: Is there reason for concern? *Catheter Cardiovasc Interv* 2010;76:826-834.

injury. Be cognizant of the air kerma during the procedure, so you know when you are approaching levels of radiation that might result in a permanent injury. Air kerma is often not an accurate measure of peak skin dose. It is nevertheless a valuable tool to identify patients who may be at risk.

- ✚ Prolonged interventional procedures may approach or exceed the 3 Gy level. You can expect transient erythema in some of your patients. You should learn the relationship between dose ranges and severity of injury so you can counsel patients and plan follow-up care. Studies that might result in high skin dose include:¹⁴
 - Radiofrequency cardiac catheter ablation
 - Percutaneous transluminal angioplasty (Coronary and other vessels)
 - Vascular embolization
 - Stent and filter placement
 - Thrombolytic and fibrinolytic procedures
 - Percutaneous transhepatic cholangiography
 - Endoscopic retrograde cholangiopancreatography
 - Transjugular intrahepatic portosystemic shunt procedure
 - Percutaneous nephrostomy, biliary drainage or urinary/biliary stone removal
- ✚ If a patient sustains an estimated skin dose over 5 Gy, arrange for a skin inspection at about 2 weeks. If erythema is noted at that time, plan for long term monitoring. The erythema will usually resolve completely. At high dose levels, or in patients with susceptible skin, tissue necrosis can develop after several months and up to two years later.

¹⁴ FDA Warning, Avoidance of serious x-ray induced skin injuries to patients during fluoroscopy-guided procedures. September 9, 1994.

Fluoroscope Technology and Image Quality

Fluoroscopes vary in size and complexity from mobile C-arms to fixed interventional suites. Yet all of these systems have common features. In this section we will discuss the parameters and controls that affect image quality and dose to the patient.

Overview

X-rays are produced in the x-ray tube. They pass through a collimator that defines the width of the x-ray beam. Upon entering the patient, some of the x-ray photons are absorbed, some are scattered, and others pass through without interacting. The degree to which x-rays pass through tissue without interacting and strike the detector determines whether that tissue appears bright or dark on the image.

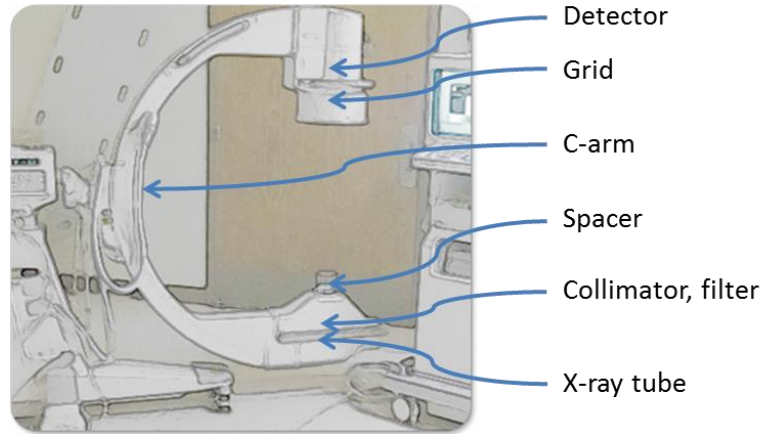

X-ray Production

In an x-ray tube, free electrons are generated at the cathode by heating the cathode filament with a

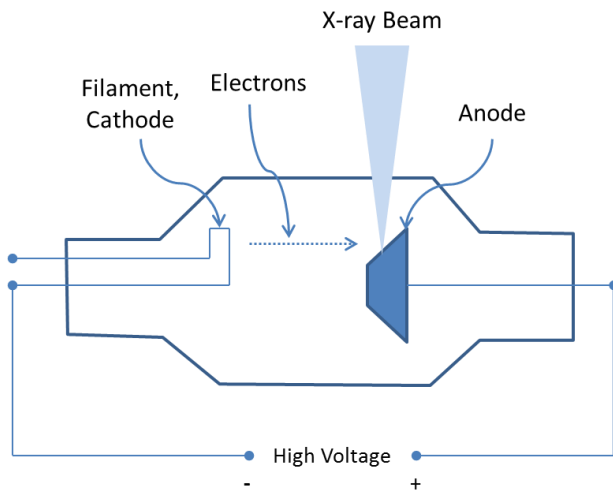

current. The electrons are then accelerated across an electrical potential. X-rays are formed when the electrons rapidly decelerate as they collide with a tungsten target called the anode. X-rays are given off in all directions, but shielding absorbs all of the photons except those that leave through the collimator.

The diagram to the left identifies the main components of an x-ray tube. The cathode filament current and the accelerating voltage are the two most important parameters in defining the appearance of a fluoroscopic image.

Tube Current (mA)

The tube current refers to the current in the cathode filament. The greater the current, the more electrons are released, and the more x-rays photons are produced. Tube current is expressed in milliamperes (mA). mA is a critical parameter. Too few photons and images are grainy. Too many photons and the x-ray detector is overwhelmed.

Tube Voltage (kV)

The tube voltage controls the energy of the electrons, and hence the energy of the x-rays. Tube voltage is expressed in kilovolts (kV). The energy of the photons determines how likely they are to be absorbed by the patient's body. As we will see later, kV determines how much light-dark contrast there is between different compositions of tissues in the image.

Radiation dose to the patient increases when either mA or kV is increased.

X-ray Interactions with Tissue

In order to understand image generation, one must know how x-rays interact with tissues. X-rays entering the patient can do one of three things:

- ✚ No interaction: The x-ray passes through the tissue along a straight line into the detector (photon path on far left in diagram to right). These are the x-rays that create the anatomic image.
- ✚ Total absorption: X-ray energy of a photon is completely absorbed by the tissue so it does not strike the detector (second photon path). The differing degree to which tissues absorb x-rays generates light and dark features on the image.
- ✚ Partial absorption and scatter: Some of the energy of the photon is absorbed and the photon, now of lower energy, is scattered. Scattering occurs in all directions. The scattered photons may irradiate the operator or others in the room. They may fall on the detector, resulting in degradation of the image by a background haze that does not contribute useful anatomic information (third photon path). They may be absorbed by a subsequent interaction with patient tissues (fourth photon path).

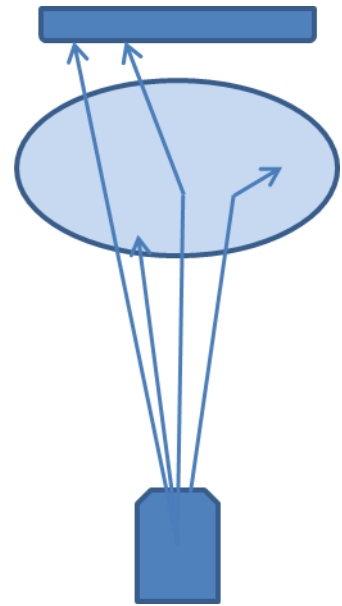

Factors that Affect Radiation Interaction

Radiation interaction with tissues is affected by these factors:

- ✚ Density and atomic number: The absorption of photons and consequent attenuation of the x-ray beam increases with the density and atomic number of the material encountered. Air is the least dense material, followed by fat, soft tissue organs and muscle, bone, radiographic contrast material, and metal. Radiation passing through dense and high atomic number materials such as bone, metal, and contrast material is largely absorbed, resulting in few x-rays at the image intensifier.
- ✚ Tissue thickness: Thicker parts of the body remove more x-rays from the beam than do thinner parts. Thicker body parts also produce more scatter.
- ✚ X-ray energy: Increasing the x-ray tube voltage results in energetic radiation with greater penetration that is less likely to be absorbed. But the image contrast between different tissues is reduced and contrast material becomes less visible. For example, at a low kV the x-ray beam is mostly absorbed by bone so the contrast between bone and soft tissues is strong, while at a

higher kV x-rays pass through bone more easily, so that the contrast between bone and soft tissues is diminished. Fluoroscopy usually employs tube potentials in the range of 50 to 120 kV. This is because x-rays at these energies provide the best compromise of tissue penetration and contrast.

The left image below shows a phantom acquired with high kV, and the right with low kV. Note the improved bone contrast when using lower tube voltage.

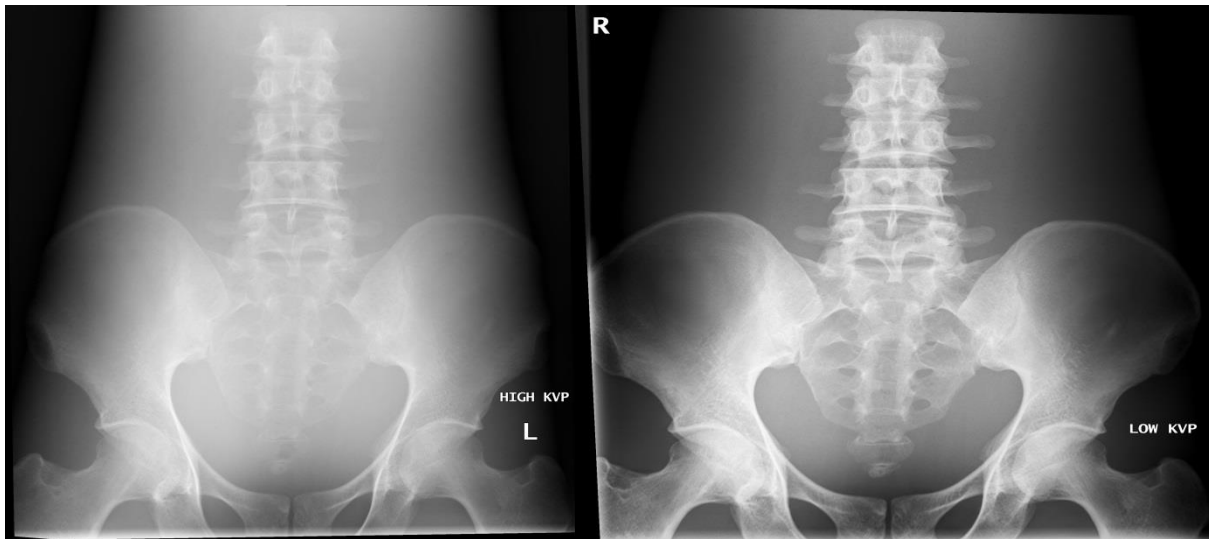

Noise

In this context, noise is the random variation in the intensity of individual image pixels that do not provide information about the patient's anatomy or material in the patient. It is sometimes referred to as "graininess" or "snow." A major source of noise, commonly the most important, is random variation in the number of x-ray photons detected by individual areas on the detector. This phenomenon is called "quantum mottle." These variations become apparent if there are insufficient x-ray photons reaching the detector elements of the detector. Another source may be electronic noise. Noise is especially apparent when you are subtracting two similar images, as you would do in digital subtraction angiography (DSA). Factors that can influence image noise include:

- ✚ mA and kV: Thicker patients and oblique and lateral views require greater radiation doses or more energetic beams to maintain the image quality.
- ✚ Resolution: When a magnification mode is selected, the smaller detector area requires more photons per area to maintain the same level of noise. In this case, the mA and possibly the kV must be increased to achieve the same level of apparent image noise.
- ✚ Duration of the acquisition: Pulsed fluoroscopy with longer pulses results in more signal at the expense of motion blurring.
- ✚ Scattered radiation reaching the detector: The amount increases with the thickness of the body part and the x-ray field size.

Automatic Exposure Rate Control

Automatic exposure control (AEC), automatic exposure rate control (AERC), and automatic brightness control (ABC) are some of the alternative names for the automatic variation of mA and kV as needed for the body part being imaged. Nearly all fluoroscopy is performed using this feature. When the fluoroscope is set to AEC mode, the output from the detector is continually monitored and the x-ray settings adjusted automatically to produce consistent image brightness and quality.

If the tissue is dense or thick, mA is increased to generate more photons, and kV is increased to generate higher energy photons that penetrate better. These adjustments are made by the machine and are not directly controlled by the operator. However many machines offer more than one AEC setting, with different selections of kV and mA. Some settings provide better image contrast at the cost of more exposure to the patient, whereas others provide less image contrast, but reduce patient dose.

On many machines you must set the controls to thin, average, or large body size. If you image a large patient with a large patient setting, the machine will automatically increase kV with mA. For machines that allow the operator to set their own manual technique selections, it is valuable to know what kV settings are typically used.

- ✚ For small body parts such as hands, the best kV for image contrast is about 70 kV. This setting produces excellent tissue contrast.
- ✚ For large body parts, such as the trunk of adults, a setting of 70 kV would necessitate a very high mA. In order to reduce patient dose, and prevent excessive heat load to the anode, a voltage of 110 or even 120 kV may be necessary. A high voltage produces an image that appears "flat" in contrast, but this is acceptable for many applications.

Another option is to keep the kV low but limit the mA, accepting a grainy image in order to maintain contrast. For example, when placing a feeding tube in an adult patient, one may prefer to keep the image contrast high by setting the voltage low so the feeding tube is highly visible. Image graininess would not be important in this application.

Note that, depending on the fluoroscope model, automatic exposure control may adjust other parameters as well in order to optimize the image.

Focal spot

Accelerated electrons are focused onto a small "focal spot" on the anode, where the x-rays are produced. The smaller the focal spot, the sharper is the image. However the drawback of focusing all of the electron energy on a small point is that the anode might melt. A larger focal spot allows better dissipation of heat. At least two focal spot sizes are available on most x-ray tubes: a large one, generally about 1 millimeter (mm) in diameter, and a small one of about 0.5 mm. The small size provides better image definition, but the x-ray output is limited and not sufficient for all tasks. A typical application for a small focal spot is the wrist, while a large focal spot might be used for the lumbar spine. In practice, most fluoroscopes automatically choose the focal spot for you.

If the anode heats to a level that might result in damage, the machine will turn off. An overheated tube is an indicator of high x-ray output and a warning that you are using high dose rate imaging modes or long beam-on times without interruption.

Beam Filtration

The photons in the x-ray beam are not at a single energy. The beam consists of a spectrum of photon energies, the maximum of which is the kV (or peak kV = kVp). Low energy photons contribute nothing to the image because they are all absorbed by the first few centimeters of tissue, but they do contribute to skin injury. Low energy photons can be removed from the beam before they reach the patient by means of a thin metal foil, called a filter, placed at the exit port of the x-ray tube. Some sophisticated fluoroscopes can select the degree of filtration automatically.

Collimator

The collimator is an adjustable lead shutter attached to the beam exit port of the x-ray source that can be closed down to limit the area of the body that is irradiated. By collimating the beam to the diagnostically appropriate field of view, you will minimize radiation to the patient, as well as to yourself. Image contrast and signal-to-noise ratio may also be improved because less of the patient will be giving rise to scattered photons. You will want to adjust the collimator setting during the course of the procedure.

In the example that follows taken of a phantom, narrower collimation (right) results in greater contrast and trabecular delineation.

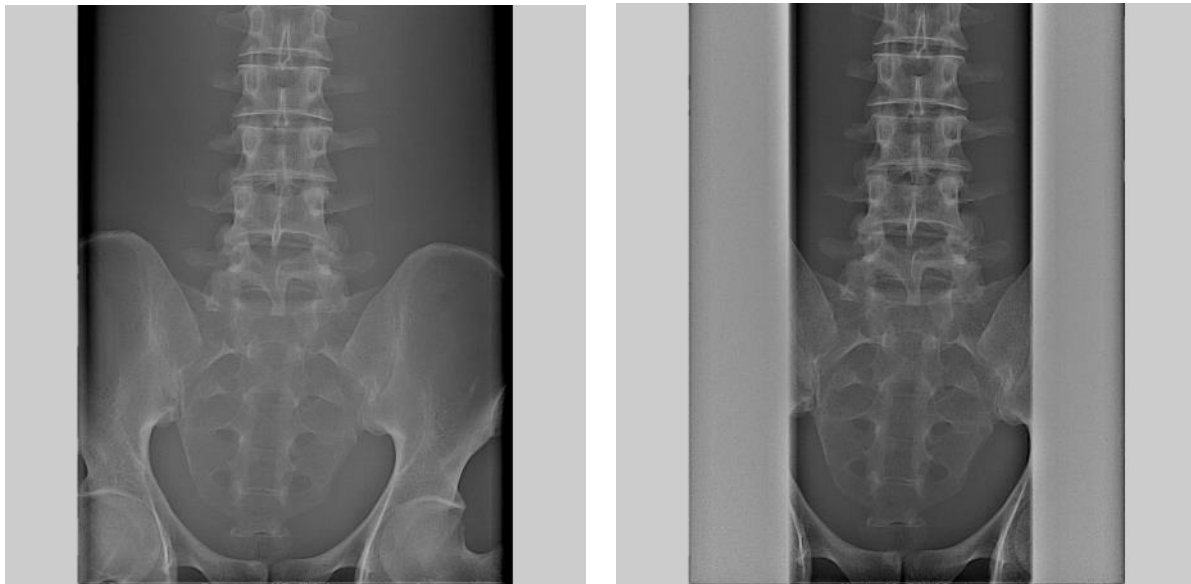

When optimizing the appearance of an image, you may need to use the collimator to help the fluoroscope find the intended setting. For example, when studying the knee with a wide open collimator, numerous photons will pass around the knee and strike the detector. mA will drop and the

knee will appear too dark. By narrowing the collimation to the width of the knee, air can be eliminated from the view and the correct exposure settings and brightness selected.

When magnification modes are employed, the collimator automatically closes as the field of view is reduced. However, you should use the collimator to further limit the field when that is feasible.

Virtual Collimation

New generation fluoroscopy systems provide a software preview of collimator adjustment in which the exposed field appears as a computer-simulated rectangle or circle overlying the most recent acquired image. This is sometimes called virtual collimation. Use this feature to eliminate the unproductive radiation that otherwise would be required to finely adjust the collimator.

Separator/Spacer

The spacer is a safety device attached to the x-ray tube housing that keeps the patient from getting dangerously close to the x-ray source. Placing the source too close to the patient is a leading cause of skin injury. The U.S. Food and Drug Administration (FDA) requires fluoroscopic x-ray machines to maintain a minimum distance between the patient's skin and the x-ray tube. For modern fluoroscopes that are fixed in a room, the minimum distance is 38 cm; for mobile units the minimum distance is 30 cm (21 CFR Part 1020).

On some machines, particularly mobile machines, the spacer can be removed because it can inhibit placement of the x-ray unit under a bed-bound patient or operating room table. The practice of removing a spacer is not without risk. Extra attention should be paid to maintaining distance between the patient and the x-ray source. The spacer should be replaced after the procedure.



Patient Table

Hospital beds and gurneys are not optimal for fluoroscopy because they may contain metal or other dense materials that impede the beam. A dedicated fluoroscopy table is made of materials that are transparent to x-rays. Most tables are height adjustable. On high-end fluoroscopy units, the table is motorized and can be programmed to move the patient with, for example, the passage of intravascular contrast material down the leg.

Image Receptor/Detector

An image receptor or detector converts x-rays to a signal that may be viewed as an image on a display monitor or that may be stored. There are two types of detectors: image intensifier tubes and flat panels. A flat panel detector is less bulky than an image intensifier and has greater sensitivity to x-rays.

Anti-Scatter Grid

An anti-scatter grid intercepts the x-rays scattered by the patient that can cause clouding of the image, while allowing transmitted x-rays to pass through. Without a grid, much of the radiation reaching the

detector is scattered x-rays.

A grid consists of numerous tiny thin plates of lead that are aligned toward the source. The grid is placed just before the detector. Only photons that are moving in a straight line from the source, i.e., not

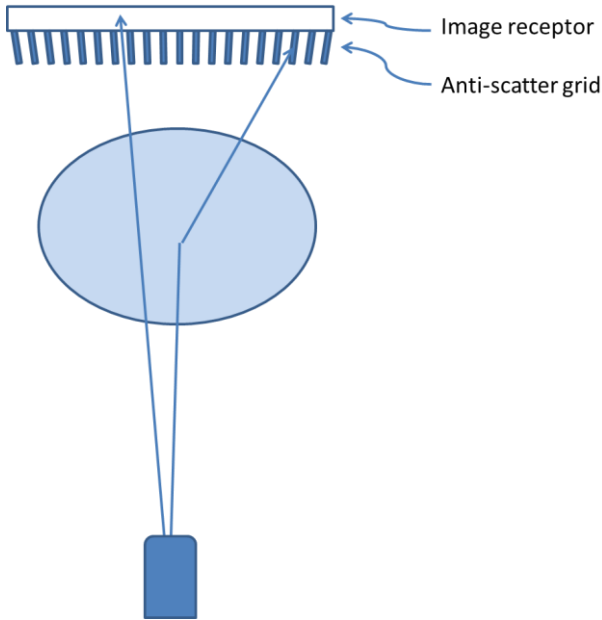

scattered, can pass between the lead plates and strike the detector.

In the illustration to the left, the photon on the left passes through the patient and the grid to the detector. The photon on the right is scattered to a new direction, and is intercepted by the grid.

Unfortunately, the grid also removes a significant fraction of the potentially useful unscattered x-rays that strike the lead plates edge-on. Use of a grid increases dose to the patient by a factor of 2 or more because the machine will need to compensate for the loss of transmitted x-rays. Therefore, grids should not be used when scatter is low, as in small children or thin body parts.

Note that not all systems have removable grids.

Beam On-Off Switch

Fluoroscope x-ray beams are turned on using either a hand or foot switch. These controls require continuous pressure and automatically disengage when released. The intent of the switch design is to ensure that x-rays are produced only as you need them, so the fluoroscope cannot be left on by mistake.

Last Image Hold

The last image hold feature on fluoroscopes refers to the fact that the last image is displayed on the monitor when the beam is turned off rather than letting the screen go blank. Last image hold allows the operator to study the last image (or multiple prior images) without irradiating the patient. For this reason, FDA requires manufacturers to provide all new fluoroscopes with last image hold capability.

You can save the last image so it can be reviewed later on a diagnostic workstation or PACS (see example on right). This is called



“fluoro store” or “last image grab. “

Continuous vs. Pulsed Modes

Modern fluoroscopes are equipped with two modes of operation whereby the electrical current to the x-ray tube is applied continuously, or pulsed on and off. When using pulsed fluoroscopy, the beam is off between pulses but the image is displayed continuously and updated with each pulse. Because the beam is mostly off, pulsed fluoroscopy is a means to reduce radiation to the patient.

Pulse Rate

The pulse rate can be selected. Common rates are 3.75, 7.5, 15, and 30 pulses per second. Selection of the best pulse rate depends on how quickly objects are moving. If motion is slow, 3 images per second may be adequate, and considerable radiation dose saving is gained. If one is following the delicate motion of intravascular catheters, or passage of contrast through coronary arteries, the pulse rate must be higher, in order to avoid choppy motion on the display screen. For coronary procedures in adults, a pulse rate of 15 per second is commonly used, but greater pulse rates such as 30 per second may occasionally be required. In the cardiac electrophysiology laboratory, a pulse rate of 7.5 frames per second is commonly employed.

Very high pulse rates (e.g., 30 pulses per second) may result in little or no dose savings. In fact, for very high pulse rates, the dose rate may be slightly greater than that for continuous fluoroscopy.

Pulse Length

The pulse length (or pulse width) is the time each pulse is on. Short lengths can reduce motion blurring, but mA is usually increased so dose savings are small. The fluoroscope may automatically adjust pulse length as part of the automatic dose rate control algorithm. Short pulse lengths should be selected when imaging young children.

High Dose Modes

High Dose Rate ("Boost") Mode

Normally the fluoroscope is automatically limited to an estimated skin dose of 0.1 Gy per minute. This is an FDA regulation. Boost mode allows you to override that safety feature. Boost mode increases the intensity of the radiation beam by a factor of two or more. Activation of boost mode requires that you push a switch continuously. When active, you will hear a continuous audible signal. Boost mode is limited to an estimated skin dose of 0.2 Gy/min.

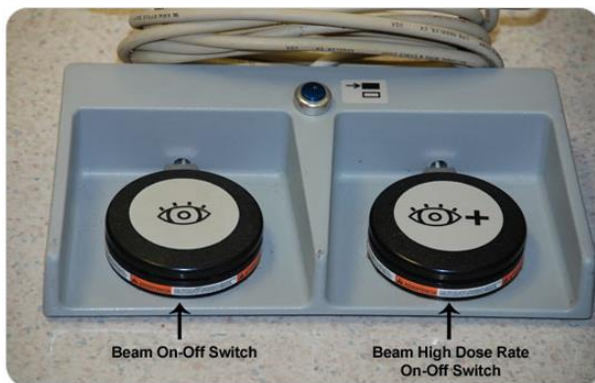

During boost mode, the radiation dose can accumulate quickly. Boost mode should be used sparingly, and only when necessary. Be sure to know which button activates normal fluoroscopy and which activates boost mode. In the photograph to the left, the normal and high dose

pedals could be confused.

Fluorography

Fluorography is the digital recording of a still image or sequence of images by a fluoroscope, of quality nearly equal to conventional radiographs (plain films). This is done to record parts of the clinical procedure or to produce images for study and analysis after the procedure is completed. Examples of fluorography are “spots,” cineangiography (“cine”), and digital subtraction angiography (DSA).

The image on the right is a fluorograph taken while checking the position of a central venous catheter. Note it is less grainy than the example of last image hold above. Compared to fluoroscopy, the dose rate of fluorography is 10 to 60 times greater. Like pulsed fluoroscopy, fluorography can be acquired as a series of images, the difference being that each high-quality fluorographic image can be examined in detail.

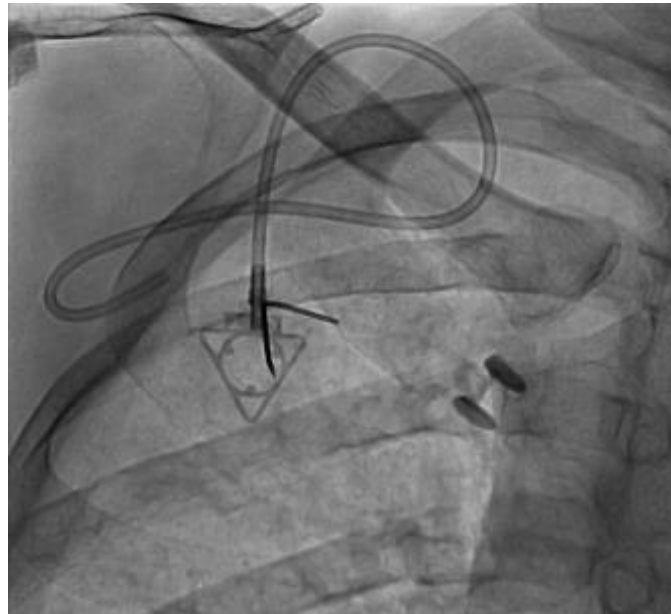

The dose rate of cinefluorography increases with frame rate. 15 frames per second are typically used for adult cardiovascular imaging. Dose to the patient is reduced by using as low a frame rate as acceptable and limiting the duration and number of cinefluorography runs.

A lower dose alternative to cinefluorography is to store a fluoroscopic series. Newer fluoroscopes temporarily keep the last dozens or hundreds of fluoroscopy frames in a buffer. These can be stored after the fact without exposing the patient to additional radiation.

Magnification

Magnification can be achieved either electronically (detector size magnification) or by adjusting the distance between the source, patient, and detector (geometric magnification). As a rule, patient dose rises dramatically with magnification. As you increase the magnification, the number of x-ray photons per pixel will decrease. The automatic exposure control on the fluoroscope will then increase the radiation output accordingly to produce a viewable image. In general, you should only use any method of magnification if it is necessary for the procedure. The balance you want to achieve is to use the least degree of magnification yet still achieve a diagnostic image.

Detector Size Magnification

In an electronic magnification mode, the image information from only part of the detector is expanded to fill the entire active area of the display monitor. Most fluoroscopes offer several degrees of electronic magnification, expressed in field of view. A smaller field of view improves visualization of

small structures at the expense of higher dose. For example, you may be imaging a patient at a 25 centimeter (cm) field of view and 0.3 mGy per second dose rate. Based on your procedural needs, you might then reduce the field of view to 12 cm by selecting an electronic magnification mode. Selecting this magnification mode increases the patient's dose rate by a factor of two to four (1.2 mGy per second), depending upon the system, in order to provide sufficient photons for the detector.



On the left is an example of an arthrogram obtained with detector size magnification.

Geometric Magnification

As you move the detector away from the patient, or the patient closer to the source, you will note the patient appears larger. As a result of the diverging x-ray beam, the apparent size of the patient at the detector is the actual size multiplied by the ratio of the distance from the source to the detector divided by the distance from the source to the patient. This is called geometric magnification. As was the case in detector size magnification, geometric magnification causes the radiation output of the x-ray source to be increased.

A Note on Mini C-arms

A mini C-arm is a small fluoroscope whose source-to-detector distance is about one-half that of a full size C-arm. Its small size makes it convenient for manipulations and operative procedures of the extremities, such as hands and wrists. Radiation to the *practitioner* is low because the distance from the source to the detector is short (so lower mA), the scatter from extremities is small and the procedures are brief.

But radiation to the *patient* can be about one-half the radiation from a full size unit, and even higher than a full size unit if an inappropriately large body part is being imaged. Because the C-arm is small, there is the potential to position a body part close to the x-ray source. Unlike standard C-arms, it is recommended that the x-ray source be placed above the patient so the extremity can rest on the detector and away from the source. The practitioner will want to avoid putting their hands in the primary x-ray beam.



Need for Training

Fluoroscope controls are complicated and differ by vendor and model. It is possible to select an imaging mode or setting that increases the dose to the patient many-fold without you being aware of the enhanced dose rate. Your department or hospital should develop a means to provide hands on training.

Key Points

- ✚ mA and kV are the key parameters that affect image appearance and patient dose. The fluoroscope can adjust these values for you, but you must specify the appropriate procedure class, or protocol, and patient size.
- ✚ Image noise decreases as mA is increased. To some degree, the safe practice of fluoroscopy consists of deciding when improved image quality is necessary for the procedure, or can be avoided to reduce radiation dose. High image noise is acceptable for some procedures. Note that when increasing mA, one eventually reaches an adequate dose rate beyond which additional mA does not result in further improvements to the image, but just increases radiation to the patient.
- ✚ Increasing kV also increases dose, assuming mA stays the same. But usually when kV is increased the mA is automatically lowered, so raising kV is a good means to reduce dose when imaging large body parts.
- ✚ You should know the difference between fluoroscopy and fluorography. Fluoroscopy is routine real time imaging, performed at a relatively low dose rate. The noise on fluoroscopic images is not apparent when averaged over moving images. Fluorography is high dose rate imaging with quality equivalent to “plain films.” An example of fluorography is cineangiography with or without digital subtraction.
- ✚ Stored images that you review after the procedure are usually fluorographs, but many machines temporarily save recent episodes of fluoroscopy and allow you to permanently store them after the exposure as a low dose alternative.
- ✚ The high dose modes are fluorography, magnification, and boost mode. These modes are selected when image quality is of paramount concern. Increased dose when using these modes will be reflected by an increase in the air kerma.
- ✚ Obese patients require higher dose, even for standard fluoroscopy. This higher dose will be reflected, in part, in an increased air kerma (but will not be completely accounted for if the skin is closer to the x-ray source than the reference point).
- ✚ If the patient gets too close to the x-ray tube (often an arm) skin dose can rise to dangerous levels. This increased risk is hidden. It is not reflected in the air kerma.

Minimizing Dose to the Patient

When using diagnostic x-rays, you have several obligations to the patient.

- ✚ Perform the procedure only if it is indicated. This requires a consideration of risks, benefits and alternatives.
- ✚ Inform the patient of likely risks before the procedure, and of any anticipated radiation complications after the procedure.
- ✚ Expose the patient to as little radiation dose as is practicable without compromising the performance of the procedure.

Strategies

The following is a list of strategies that should be employed in minimizing patient dose.

Ensure the Procedure is Indicated and Safe

Utilize accepted appropriateness criteria or practice guidelines. Avoid repeating a study if the results can be obtained from another institution. Inquire about prior procedures or skin injury. Obesity greatly amplifies the risk of radiation injury.

Screen for Pregnancy

Ask female patients of reproductive age whether they could be pregnant. Unless the procedure is emergently necessary, perform a serum pregnancy test when the procedure is likely to impart a radiation dose to an embryo or fetus exceeding 0.1 Gy. A radiation dose of 0.1 Gy is only reached during prolonged studies involving direct imaging of the abdominal or pelvic region. If the patient is pregnant, consider whether the study can be delayed until the pregnancy is completed. If the procedure must be performed, take actions to limit the dose to the embryo or fetus.

If the patient is found to be pregnant following a procedure it may be appropriate, depending on institutional guidelines, to have a medical physicist or radiation safety officer estimate the fetal dose.

Inform the Patient of Radiation Risk

It is good practice to include the possibility of erythema or epilation in the informed consent if the patient may be exposed to more than 3 Gy skin dose.¹⁵ By noting the air kerma after every procedure, you will quickly learn what estimated dose to expect.

Informed consent should be obtained for abdominal or pelvic fluoroscopy if the patient is pregnant.

Informed consent for cancer risk is challenging because a relationship between radiation and cancer is suspected but not confirmed for low dose fluoroscopic exams. For the elderly patient the discussion is probably unnecessary. When speaking with the parents of children, and to young adults, you might state that if there is a risk it is very small, is much smaller than the risk of not having the procedure, and you will take precautions to keep the dose as low as possible.

¹⁵ ACR-SIR Practice Guideline on Informed Consent for Image Guided Procedures (2011). www.acr.org

Rehearse the Procedure

Know in advance the steps of the procedure and the necessary images you must obtain. This will reduce beam-on time. If you are learning a new procedure, you may wish to write down the procedure steps..

Position the Patient

The safest position for the patient is as far as practical from the x-ray tube and as close as practical to the detector.

The fluoroscope position depicted on the left would result in a dose to the patient that was several times greater than the position on the right.



Lateral approaches require higher doses than do posteroanterior approaches because the beam must pass through a greater tissue thickness.

When imaging the chest or abdomen, keep the arms out of the beam. On occasion, an arm has inadvertently been allowed to lie in the primary beam for protracted periods during lateral or steep oblique imaging. The increased tissue in the beam causes the machine to greatly increase the intensity of the x-ray beam. In addition, the arm may be too close to the x-ray source. Terrible radiation injuries have resulted. If the patient is draped, ensure that arms cannot slide off the edge of the table and on to the source cowling or separator.

If possible, avoid exposing the patient's eyes directly to the primary entrance beam.

For a thoracic procedure on a young female patient, place the x-ray tube on the side opposite of the breasts if feasible.

Set Fluoroscope Parameters

Most fluoroscopes offer several modes optimized for particular sizes of patients and classes of procedures.

Select a Low Pulse Rate

Use pulsed fluoroscopy whenever possible and select the lowest acceptable pulse rate. A rate of 7.5 frames per second is adequate for many procedures.

Avoid Unnecessary Magnification

Keep magnification off unless you need it. When using it, don't magnify more than you need.

Collimate the Beam

During the course of the procedure, adjust collimation to radiate the smallest field necessary. This will improve image contrast, lower the dose area product to the patient, and lower dose to you as well. By

keeping the field of view small, you can further apply the principle of dose spreading.

Spread the Dose

If prolonged exposures to one structure are required, you might close down the collimator as much as possible. Then by examining the structure from varying degrees of obliquity of the C-arm (two obliquities are depicted on the right) you can spread the entrance skin exposure over several different skin sites. This is called "dose spreading."

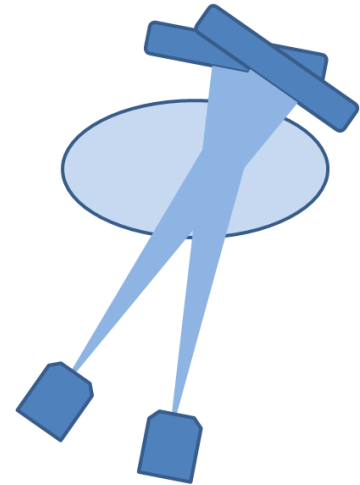

If a structure is imaged from two different projections, but the projections are not sufficiently different to prevent some of the skin from being exposed by both, then the area of overlap may become erythematous, while the center of each exposed field does not.

Use Last Image Hold

Keep your foot off the pedal when nothing is moving. By means of the last image hold feature you can inspect the image while the beam is off. "Tap fluoroscopy" refers to the practice of periodically tapping on the pedal to update the image. This practice is an effective means to reduce the total beam-on time when little is changing, or if one simply wants to check the location of an instrument.

Turn Down the Room Lights

Subdued lighting around the display monitor will substantially improve apparent image contrast.

Minimize Procedure Time when Imaging Obese Patients

Complex interventions on the morbidly obese should be performed with reluctance. Obese patients are the most likely to receive a skin injury. They require high dose rates, and their skin will usually be closer to the x-ray source than will standard patients. Furthermore the kV may be high, resulting in a low contrast image that may impede your ability to carry out the procedure. For these patients make an effort to reduce the beam-on time to as little as possible.

Be Cognizant of Dose

Assign someone to notify you when certain dose thresholds are exceeded. The Society of Interventional Radiology recommends the technologist inform you when cumulative air kerma has reached 3000 mGy, and again at each additional 1000 mGy.¹⁶

Record and Review your Dose

We recommend that each department or hospital maintain a record of patient dose metrics. This record would include the date, procedure, practitioner, cumulative air kerma, kerma area product, and total fluoro time. In cardiac angiography one could also record the air kerma from cine imaging. Most fluoroscopes can automatically send the dose to a database or to PACS by means of an image of the

¹⁶ Stecker MS et. al. Guidelines for Patient Radiation Dose Management. J Vasc Interv Radiol 2009;20:S263-S273.

dose summary or by a Radiation Dose Structured Report (RDSR). This record should be reviewed periodically as part of a QA program. Software is commercially available to perform dose comparisons.

The picture below is a captured image of a summary dose report that was saved to PACS. Note that the

The screenshot shows a 'Dose report' window with two columns of patient and exam information. The left column includes Patient Name, Patient ID, Date of birth, and Sex. The right column includes Hospital name, Physician, Exam type, Date (07-23-2013), Time (15:13), and Accession Nr. Below this is a table with five columns: Mode, Cumulative dose (mGy), (Gy.cm²), Time (mm:ss), and No. The table has two rows: 'Dynamic acquisition' and 'Total'.

Mode	Cumulative dose (mGy)	(Gy.cm ²)	Time (mm:ss)	No.
Dynamic acquisition	79.4	16.9	7:26	
Total	79.4	16.9	7:26	

vendor does not explicitly use the terms “air kerma” and “kerma area product” but these parameters can be identified by their units, mGy and Gy \cdot cm². Detailed dose reports are available that tell you how much dose

accrued in each imaging mode.

Documenting High Dose

If 3 Gy dose is exceeded, one should document in the medical record the cumulative air kerma or estimated skin dose and the site of peak skin dose so that subsequent practitioners can better treat the patient.

Reporting High Dose

If 15 Gy dose is exceeded, or if a patient receives a permanent skin injury, the case should be formally reviewed and causes established, in keeping with your hospital policy for reporting patient injuries, and with The Joint Commission sentinel event standard.

Key Points

It all adds up. The decisions to

- ✚ maximize source-to-patient distance and minimize patient-to-detector distance,
- ✚ select low pulse rates,
- ✚ use the least magnification acceptable,
- ✚ don't use a grid for small body parts and small children,
- ✚ avoid steeply oblique or lateral projections when possible,
- ✚ collimate the beam,
- ✚ spread the dose,
- ✚ minimize beam-on time, and
- ✚ limit the number of fluorographic images recorded

are not small factors. Each of these choices often reduces dose rate by a factor of one-half or more. Use of all of these techniques together can reduce dose dramatically.

Pediatric Fluoroscopy

Special care should be taken when the patient is a child.

Risk of Cancer

Radiation at an early age is more likely to result in cancer than radiation late in life. Ask about prior x-ray procedures. Use alternatives to x-ray procedures whenever possible, such as ultrasound and MRI. Minimize radiation to the breast, eyes, thyroid and gonads.

Include the Family

The Image Gently organization has resources to help you with the radiation risk discussion.¹⁷ In many hospitals a parent, but not a sibling, is allowed in the room during the exam. This can reduce child anxiety and increase cooperation, thereby improving exam quality and lowering dose to the child.

Reassure the Child

Keep the child comfortable and relaxed. Child friendly environments include music and video. Neonates and young children prefer or require warm room temperatures. Immobilize the child if necessary so that the procedure time is not extended by patient motion.

Know the Medical History

Tailor the exam according to the past medical history and specific questions to be answered.

Communicate Frequently and Clearly

The exam time can be reduced by keeping the team aware of necessary positioning as well as amounts and intervals of contrast media. Be sure to communicate with the nurse or other persons in the room who are primarily engaged in monitoring the child, so they know when to step back from the table. Interrupt fluoroscopy if the nurse must attend to the child.

Don't Use the Grid

If the child is small (less than about 8 years), there will be little scatter when imaging the chest and abdomen. Avoiding use of the grid will reduce radiation dose.

Select the Appropriate Imaging Mode

Use an imaging mode appropriate to the size of the child so that mA and kV are optimized for a small body. The recommended kV may be lower than that used in adults. In pediatric pulsed fluoroscopy, the pulse length is reduced to less than 5 msec to sharpen the image. Contact your vendor technical representative to ensure that pediatric settings are supported by your equipment.

Use Extra Filtration

Pediatric modes often apply an additional filter to remove low energy photons from the beam.

¹⁷ www.imagegently.org

Avoid Magnification

You may need to zoom in on the image in order to visualize small anatomy. Use a large display monitor. If your equipment supports it, enlarge the image in the post-processing step rather than using geometric or electronic magnification.

Use Dose Sparing Techniques

As with adult patients, minimize the fluoroscopy time, utilize collimation, last image hold, low pulse rates and short patient to detector distance. Store fluoroscopic images rather than fluorography. Maintaining a long source to patient distance will not be difficult for a child. Don't leave the beam on continuously while positioning the tube and moving the collimators.

Minimizing Dose to the Practitioner

Methods that reduce dose to the patient also reduce dose to the fluoroscope operator. That is because scatter from the patient is the greatest source of radiation to the operator. Limiting beam-on time, collimating the beam, and using low pulsed fluoroscopy rates all reduce dose to staff.

Occupational Exposures

Limits for Federal Institutions

The U.S. Occupational Safety and Health Administration (OSHA) has established limits for radiation to the practitioner and other staff in the room, as specified in Title 29, Part 1910.1096, of the Code of Federal Regulations. These regulations state that the employer cannot cause an employee to be exposed beyond the following levels:

- ✚ More than 1.25 rem (12.5 mSv) to the whole body, head and trunk, or lenses of the eyes in any quarter of the year.
- ✚ More than 3 rem (30 mSv) per quarter provided that the cumulative lifetime dose does not exceed $5(N-18)$ rem, or $50(N-18)$ mSv, where N is the age of the employee in years.
- ✚ More than 18.75 rem (187.5 mSv) to the hands and forearms or feet and ankles in any calendar quarter.

Radioactive Material Workers

If the operator uses radioactive materials, he or she will need to adhere to NRC occupational exposure limits for fluoroscopy instead of OSHA limits. In that case the sum of the exposures from x-rays and radioactive materials must not exceed NRC limits.

Limits for Private Sector Institutions

Non-federal facilities are subject to state regulations. Most states have adopted the Nuclear Regulatory Commission (NRC) Title 10, Part 20 CFR limits of:

- ✚ 5 rem (50 mSv) per year to the whole body.
- ✚ 50 rem (500 mSv) per year to the hand and forearms, feet and ankles.
- ✚ 15 rem (150 mSv) per year to the lenses of the eye.

Limits for Eye Exposure

The International Commission on Radiological Protection recommends an equivalent dose limit for the lens of the eye that is lower than that required by NRC: 20 mSv a year, averaged over 5 years, with no single year exceeding 50 mSv.¹⁸

Personal Dosimetry

Personnel who routinely enter the fluoroscopy room during a procedure must wear a dosimeter, often called a radiation badge, at the collar but outside of the lead apron, to monitor dose to the face and

¹⁸ ICRP, 2011, Statement on Tissue Reactions. ref 4825-3093-1464.

eyes. In addition to the mandatory collar badge, employees can wear an optional second badge on the chest or abdomen under the protective apron.

Store your dosimeter away from x-ray equipment and other sources of radiation. A common error is to leave it on the lead apron in the fluoroscopy room. Some types of dosimeters may give false readings if exposed to heat. Don't wear your badge if you become a patient – it is intended to monitor occupational exposure only. The radiation safety officer and radiation safety committee at your facility should review high doses to employees. If exposures approach specified levels, a plan should be devised to improve safety practice or reduce the number of procedures.

Finger Dosimeters

An operator whose hands may approach the radiation field can request a finger dosimeter to measure



hand exposure. The finger dosimeter looks like a ring and can be worn under a sterile glove. Some dosimeter rings can be sterilized. The ring should be worn on the hand likely to receive the largest dose with the sensitive badge area turned toward the beam. Be aware that the ring detects radiation at the base of the finger rather than at the fingertip where the dose may be higher. Wear the finger dosimeter for several months as a tool to troubleshoot technique and reduce radiation exposure.

Basic Principles of Personal Radiation Protection

The four primary methods of personal radiation protection are:

- ✚ Time: Minimize the time the beam is on.
- ✚ Distance: Stand as far back as reasonably possible from where the beam enters the patient.
- ✚ Shielding: Wear protective aprons and use x-ray barriers.
- ✚ Patient dose reduction: Collimate the beam as narrowly as practicable and use other dose sparing techniques.

Time

Don't turn the beam on unless you must view a live image. Use last image hold whenever possible.

Modern fluoroscopes emit an audible signal after each five minutes of beam-on time. This alarm must be manually reset. By keeping track of 5 minute intervals, one knows whether the procedure is taking longer than usual.

Distance

The main source of exposure to staff is scatter from the patient, and primarily from the entrance skin. The level of scattered radiation drops quickly with distance from the entrance skin, according to the inverse square law. For example, the dose rate to an operator standing 30 cm away from the entrance skin is 100 times greater than the dose rate to an observer 3 meters distant. Another way to think of this is that standing back 3 meters affords as much protection as wearing a lead apron.

If the x-ray tube is below the patient, most of the scattered x-rays are directed down at the thighs of the

operator. If the tube is above the patient, scattered x-rays are primarily directed up at the operator's arms, chest and face. The reason why scattered x-rays are greatest on the same side of the patient as the tube is because most x-rays scattered forward are absorbed by the patient's body. Whenever possible, the x-ray tube should be below the patient, or on the far side of the patient in the case of a cross-table exam.

The diagrams below depict scatter radiation for a C-arm fluoroscopy system with the x-ray tube under the table (left) and in lateral projection on the same side as the operator (right).¹⁹ Note the high dose to the operator when standing on the same side of the patient as the tube.

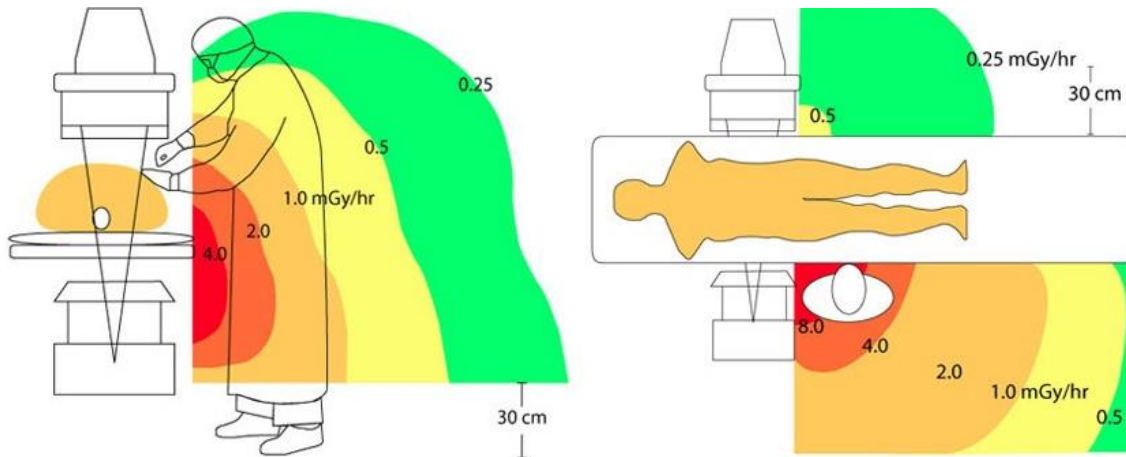

If the operator stands upright, scattered radiation to the face is perhaps one-fourth as great as when the operator is leaning down toward the patient. Short operators receive more radiation to the face than do tall operators. They may wish to stand on a platform.

The nurse who sits next to the patient's head during a procedure may incur high dose on her collar dosimeter. A typical dose rate at that location might be 10 mGy per hour. A better position for the nurse would be standing. Better yet the nurse could stand a few feet back from the table and approach the patient periodically. During DSA or cine runs, the nurse should stand behind a protective barrier or step out of the room and observe the patient through the control window.

Urology units often place the tube above the patient because the physician is sitting low beneath the plane of the patient. Note that many newer generation units place the tube below the patient, but have radiation shields under the table.

Shielding

Shielding comes in many forms, including lead in walls and windows, transparent ceiling-suspended barriers, lead aprons, and even other people in the procedure room.

¹⁹ Reprinted with permission. Schueler, BA. Operator shielding: How and why. *Techniques in Vascular and Interventional Radiology*. 2010;13:167-171.

Aprons

Protective aprons with 0.5 mm of lead, or other equivalent material, are commonly worn by members of the fluoroscopy team. They attenuate radiation by about 97 percent. If you experience back and shoulder pain, you can reduce the weight on your shoulders by means of a two piece garment consisting of a skirt and vest. Light weight aprons are available made of composite materials.

Lead aprons can crack with time if they are folded. Hang them up when not in use. Aprons should be inspected at least yearly for damage.

Thyroid Shields

These should be worn by males under 30 years old and females under 40 years old to minimize the chance of thyroid cancer.

Eye Protection

If you perform interventional procedures and stand next to the table, protective shields are recommended to avoid cataracts. Transparent ceiling-mounted shields are available, sometimes with a flexible lead drape at the bottom of the shield. Ceiling mounted shields are most effective when they are positioned close to the patient. Not only do these protect your entire head and neck, they also reduce the dose recorded by your collar dosimetry badge, reducing the likelihood that you will exceed a dose limit.

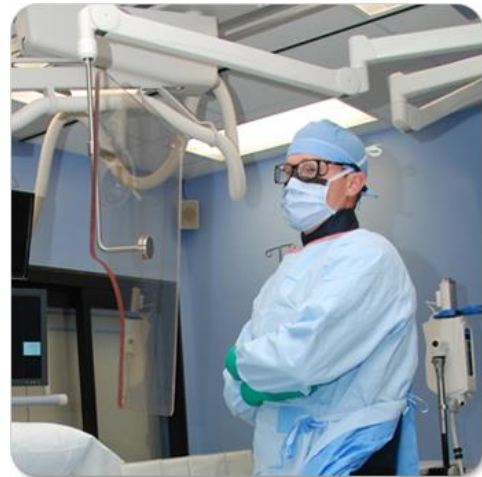

Wrap around leaded glasses or goggles may also be used.

Side shields are necessary because the operator will be looking to the side at the display monitor while the beam is on. Conventional glasses with glass lenses afford about 35% reduction in dose. Conventional plastic lenses are not protective.

Gloves

Thin surgical gloves containing lead offer little protection. It is safer to keep hands away from the beam.

Mobile barriers

These are an alternative for those who must be in the room but don't participate in the intervention.

Collimation

By reducing the size of the exposed skin field, the amount of scatter is reduced. Adjust the collimation with each repositioning of the C-arm. Kerma area product measurements are an indicator of how tightly you have collimated the beam.

Avoiding Radiation to Hands

Collimating the beam also reduces the possibility that your hands will be exposed to the primary beam. Dose rates of a beam that exits above the patient from an x-ray tube located under the patient are in

the range of 5 to 20 mGy per hour, and are about 100 times greater if the tube is above the patient. Your hands are directly exposed to the primary beam if they appear on the display monitor.

When manipulating an instrument such as an aspiration needle in the radiated field, you should either turn the beam off and on as you adjust and check the position, or else hold the instrument with a clamp. If your hands are routinely near the x-ray beam, consider wearing a finger dosimeter.

Exposure to Persons Not Involved with the Procedure

Dose to persons in surrounding spaces should not exceed 1 mSv per year. Procedure rooms typically have concrete floors and lead lined walls. But what if you must bring a mobile C-arm to a room that lacks wall shielding, or contains people not involved with the procedure? If this is a frequent occurrence, ask the physicist or radiation safety officer to devise a shielding plan. Be sure to consider dose to staff in adjacent offices.

If you must use a fluoroscope in a room without shielding, take these precautions:

- ✚ Personnel who are not needed should leave the immediate area.
- ✚ Staff and patients who are more than 3 meters away might not need to relocate during occasional brief procedures.
- ✚ Announce you are about to turn on the beam so remaining staff can put on aprons or move away as far as practicable.

Caregivers and Others in the Room

In general, visitors and family members should not enter the fluoroscopy room during a procedure. However, when imaging children, you can use your discretion in allowing an adult family member to wear a lead gown and stand in the room. Position the family member away from the table during the procedure to reduce their exposure to scattered radiation.

You should not require an employee to routinely hold down patients while they are being irradiated during a procedure.

Pregnant Personnel

Most institutions have adopted the following policy:

A woman who is pregnant may declare her pregnancy in writing. This declaration is voluntary on the part of the woman. The radiation dose to the embryo or fetus of a woman who has declared her pregnancy must not exceed 5 mSv (0.5 rem) during the pregnancy and should not exceed 0.5 mSv in any month (10 CFR 20.1208). Note, however, that this limit does not apply to pregnant employees who must themselves undergo medical procedures.

A woman who is pregnant may continue to perform fluoroscopy, or she can ask to be reassigned to a low radiation duty. If a practitioner chooses to perform fluoroscopic procedures while pregnant, she should wear a wraparound apron and a second dosimetry badge under the apron and anterior to the

uterus. This badge must be exchanged monthly.

If reassignment is requested, the supervisor is not obligated to accommodate the request if the employee's work environment does not present an unusual risk of high exposure that would exceed the limits stated above.

Key Points

- ✚ The primary techniques for reducing radiation dose to yourself and your staff are:
 - Minimize the beam-on time; especially the time spent recording images (fluorography).
 - Stand away from the beam entrance skin site.
 - Employ protective shielding.
 - Collimate the beam.
 - Use the lowest acceptable pulse rate, and other patient dose sparing techniques.
- ✚ Most practitioners will have no trouble staying below occupational dose limits. However you should go beyond this standard by keeping the dose to yourself and others as low as reasonably achievable (ALARA).
- ✚ Some cardiac and interventional physicians who perform several complex procedures per day will approach or exceed occupational limits. These individuals should take a quantitative approach to identify and correct the actions which result in high personal dose, using a dosimeter that reports dose during the procedure if necessary.

Resources

Image Wisely

An initiative of the American College of Radiology, Radiological Society of North America, and the American Association of Physicists in Medicine. It provides information for patients, and makes recommendations to physicians for reducing radiation dose in adult medical imaging.

www.imagewisely.org

Image Gently

The Alliance for Radiation Safety in Pediatric Imaging (Society for Pediatric Radiology, AAPM, ACR, and American Society of Radiological Technologists) provides radiation safety guidance for pediatric imaging, including fluoroscopy, with information for parents. www.imagegently.org

IAEA

The International Atomic Energy Agency provides educational resources on many topics of radiation safety, including fluoroscopy. www.iaea.org

NCRP

The National Council on Radiation Protection and Measurements offers publications on a variety of radiation safety issues. www.ncrponline.org

AAPM

American Association of Physicists in Medicine publishes technical standards for medical imaging. www.aapm.org

ACR

The American College of Radiology offers appropriateness guidelines and practice standards in radiology. www.acr.org

ACC

The American College of Cardiology provides appropriate use criteria and practice standards in cardiac imaging. www.cardiosource.org

SIR

The Society of Interventional Radiology publishes practice standards for interventional procedures, including radiation safety. www.sirweb.org