

DOCUMENT RESUME

ED 071 901

SE 015 538

TITLE Project Physics Teacher Guide 4, Light and Electromagnetism.

INSTITUTION Harvard Univ., Cambridge, Mass. Harvard Project Physics.

SPONS AGENCY Office of Education (DHEW), Washington, D.C. Bureau of Research.

BUREAU NO BR-5-1038

PUB DATE 68

CONTRACT OEC-5-10-058

NOTE 277p.; Authorized Interim Version

EDRS PRICE MF-\$0.65 HC-\$9.87

DESCRIPTORS \*Electricity; Instructional Materials; Multimedia Instruction; \*Optics; \*Physics; Science Activities; Secondary Grades; \*Secondary School Science; \*Teaching Guides; Teaching Procedures

IDENTIFIERS Harvard Project Physics

ABSTRACT

Teaching procedures of Project Physics Unit 4 are presented to help teachers make effective use of learning materials. Unit contents are discussed in connection with teaching aid lists, multi-media schedules, schedule blocks, and resources charts. Brief summaries are made for transparencies, 16mm films, and reader articles. Included is information about the background and development of each unit chapter, procedures used in demonstrations, apparatus operations, notes on the student handbook, and explanation of film loops. Additional articles are concerned with electromagnetic spectra, field concepts, Oersted's own account of his discovery, Romer's work, and "lectron" series. Current balances and microwave apparatus are analyzed, and a bibliography of references including that of photographic instrumentation is given. Solutions to study guides are provided in detail, and answers to test items are suggested. The fourth unit of the text, along with marginal comments on each section, is also compiled in the manual. The work of Harvard Project Physics has been financially supported by: the Carnegie Corporation of New York, the Ford Foundation, the National Science Foundation, the Alfred P. Sloan Foundation, the United States Office of Education, and Harvard University. (CC)

ED 071901

Project Physics Teacher Guide

An Introduction to Physics

Light and Electromagnetism

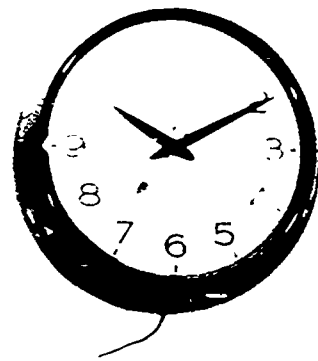

WEDNESDAY LAB  
STATIONS

SAVE

- GROUP 1 E36
- GROUP 2 E35
- GROUP 3 E37
- GROUP 4 E34



015-538

ED 071901

U S DEPARTMENT OF HEALTH  
EDUCATION & WELFARE  
OFFICE OF EDUCATION  
THIS DOCUMENT HAS BEEN REPRO  
DUCED EXACTLY AS RECEIVED FROM  
THE PERSON OR ORGANIZATION ORIG  
INATING IT POINTS OF VIEW OR OPIN  
IONS STATED DO NOT NECESSARILY  
REPRESENT OFFICIAL OFFICE OF EDU  
CATION POSITION OR POLICY

## Project Physics **Teacher's Guide**

### An Introduction to Physics **4** Light and Electromagnetism



Authorized Interim Version **1968-69**

Distributed by **Holt, Rinehart and Winston, Inc.** New York Toronto

This teacher guide is the authorized interim version of one of the many instructional materials being developed by Harvard Project Physics, including text units, laboratory experiments, and readers. Its development has profited from the help of many of the colleagues listed at the front of the text units.

Copyright © 1968, Project Physics Incorporated.

Copyright is claimed until December 31, 1968. After December 31, 1968, all portions of this work not identified herein as the subject of previous copyright shall be in the public domain. The authorized interim version of the Harvard Project Physics course is being distributed at cost by Holt, Rinehart and Winston, Inc. by arrangement with Project Physics Incorporated, a non-profit educational organization.

All persons making use of any part of these materials are requested to acknowledge the source and the financial support given to Project Physics by the agencies named below, and to include a statement that the publication of such material is not necessarily endorsed by Harvard Project Physics or any of the authors of this work.

The work of Harvard Project Physics has been financially supported by the Carnegie Corporation of New York, the Ford Foundation, the National Science Foundation, the Alfred P. Sloan Foundation, the United States Office of Education, and Harvard University.

03-080019-6

90123 69 9876543

<b>Unit Overview</b>	
Overview of Unit 4	1
Teaching Aids (list of)	1
<b>Multi-Media Schedule</b>	
Unit 4 Multi-Media Schedule	2
Details of the Multi-Media Schedule	3
<b>Organization Pages (yellow)</b>	
Schedule Blocks	
Resource Charts	
Experiment Summaries	
Chapter 13	5
Chapter 14	9
Chapter 15	13
Chapter 16	17
<b>Study Guide</b>	
Brief answers	21
Solutions to Chapter 13	23
Solutions to Chapter 14	27
Solutions to Chapter 15	32
Solutions to Chapter 16	35
<b>Background and Development</b>	
Chapter 13	38
Chapter 14	42
Chapter 15	44
Chapter 16	45
<b>Aid Summaries</b>	
Transparencies	47
Film Loops	47
16mm Films	47
Reader	48
<b>Demonstrations</b>	
D47 Some Electrostatic Demonstrations	51
D48 The Electrophorous	53
D49 Currents and Forces	54
D50 Currents, Magnets and Forces	56
D51 Electric Fields	57
D52 Demonstrations and Experiments with Microwaves	57
<b>Film Loop Notes</b>	
L41 Standing Electromagnetic Waves	61
<b>Experiment Notes</b>	
E32* Young's Experiment—Wavelength of Light	63
E33* Electric Forces I	63
E34 Electric Forces II—Coulomb's Law	64
E35* Currents and Forces	66
E36 Currents, Magnets and Forces	68
E37 Electron Beam Tube	70
E38* Waves, Modulation, Communication	71
<b>Equipment Notes</b>	
Current Balance	79
Microwave Apparatus	81
<b>Additional Background Articles</b>	
Electromagnetic Spectrum	85
Fields	87
Oersted	89
Römer	90
"Lectron" Series	91
<b>Bibliography</b>	93
<b>Suggested Answers to Tests</b>	
Test A	105
Test B	109
Test C	113
Test D	115
<b>Index</b>	119

## Overview of Unit Four

Chapters 12 through 16 should be considered together as an integrated sequence covering selected aspects of light, waves, electricity and magnetism. The primary goal of the sequence is to reach a qualitative understanding of electromagnetic waves (Chapter 16), based on the concept of electromagnetic induction (Chapter 15), and merging it with the wave description of light (Chapter 13). A secondary purpose is to provide the basic physics needed to understand the elements of electrical technology, so as to make contact with a region of applied science which has had important social consequences (Chapter 15). A third goal is to present some information about the interaction of electric charges with each other and with magnetic fields (Chapter 14), not only as a prerequisite to understanding electromagnetic induction and light, but also for later use in Units 5 and 6 in connection with experimental atomic and nuclear physics. It should be kept in mind that while Chapters 12, 13 and 14 cover a certain amount of fairly standard material on waves, light and electricity, a comprehensive treatment of these subjects is not a major goal of the course, and the temptation to delve more deeply into the topic of electric circuits should be resisted (within the context of this unit).

## Films (16 mm)

- F30 Speed of Light
- F31 Introduction to Optics
- F32 Coulomb's Law
- F33 Electrons in a Uniform Magnetic Field
- F34 Electromagnetic Waves

## Demonstrations

- D47 Electrostatic Demonstrations
- D48 The Electrophorus
- D49 Currents and Forces
- D50 Currents, Magnets and Forces
- D51 Electric Fields
- D52 Microwaves

## Loops

- L41 Standing Electromagnetic Waves

## Experiments

- E32\* Young's Experiment—The Wavelength of Light
- E33\* Electric Forces I
- E34 Electric Forces II—Coulomb's Law
- E35\* Currents and Forces
- E36 Currents, Magnets and Forces
- E37 Electron Beam Tube
- E38\* Microwaves

## Transparencies

- T30 The Speed of Light
- T31  $\vec{E}$  Field Inside Conducting Spheres
- T32 Magnetic Fields and Moving Charges
- T33 Forces Between Current Carriers
- T34 The Electromagnetic Spectrum

## Reader Articles

- R1 Letters from Thomas Jefferson, June 1799
- R2 On the Method of Theoretical Physics
- R3 Experiments and Calculations Relative to Physical Optics
- R4 Velocity of Light
- R5 Popular Applications of Polarized Light
- R6 Action at a Distance
- R7 The Electronic Revolution
- R8 The Invention of the Electric Light
- R9 High Fidelity
- R10 Future of Direct Current Power Transmission
- R11 James Clerk Maxwell—Part II
- R12 Collection of Maxwell's Letters
- R13 On the Induction of Electric Currents
- R14 Relationship of Electricity and Magnetism
- R15 The Electromagnetic Field
- R16 Radiation Belts Around the Earth

Multi-Media Plan for Unit 4

1 LAB STATION Properties of Light	2 PSSC FILM Speed of Light TEACHER PRESENTATION History of Measurement of Velocity of Light	3 SMALL GROUP DISCUSSION Is Light a Particle or a Wave? SYNTHESIZING DISCUSSION (whole class)	4 TEACHER DEMONSTRATION Conversion of Energy to Light
1a Text: Chapter 13	2a Text Continued Chapter 13	3a Reader. On the Method of The- oretical Physics, Einstein	4a Text 14.1 - 14.6
5 TEACHER DEMONSTRATION LECTURE Static Electricity	6 EXPERIMENT 34: Coulomb's Law	7 TEACHER LECTURE Current Electricity	8 STUDENT ACTIVITY DAY Unique Electric Generators  Activity. Make an Electric Generator, see Student Hand- book and other sources.
5a Text: 14.7 - 14.13	6a Reader: A Mirror for the Brain, Walter	7a Text: 15.1 - 15.5	
9 LAB STATIONS Current Balances	10 LAB STATIONS Current Balances	11 TEACHER DEMONSTRATION LECTURE Electric Fields	12 PROGRAM Electric Forces and Fields and Electrical Potential Energy
9a Reader The Invention of the Electric Light, Josephson	10a Write Lab Report	11a Text 15.6 - 15.9	12a Finish Programs
13 STUDENT DEMONSTRATION: Huggins Tube	14 TEACHER LECTURE Magnetic Fields	15 FILM Prelude to Power  Small Group Discussion on Film	16
13a Text 16.1 - 16.3	14a Text: 16.4 - 16.6	15a Reader. Scientific Imagina- tion, Feynman et al.	16a Outside Reading
17 LIBRARY RESEARCH	18 TEACHER LECTURE - DEMON- STRATION Electromagnetic machines	19 STUDENT PRESENTATIONS	20 STUDENT PRESENTATIONS
17a Reading and Recording	18a Reading and Recording	19a Finish Recordings	20a
21 TEACHER PRESENTATION Maxwell's Contribution to Science	22 LAB STATIONS Electromagnetic Waves	23 PSSC FILM Electromagnetic Waves	24 CLASS DISCUSSION Existence of the Ether and the Michelson-Morley Experiment
21a Reader: Action at a Distance, Maxwell	22a Prepare for Discussion on Day 24	23a Prepare for discussion on Day 24	24a Text: Unit 4, Prologue and Epilogue

## Multi-Media Schedule

### Details of the Multi-Media Schedule

#### Day 1

##### Lab stations: Properties of Light

1. Reflection. Locate image in a plane mirror by ray-tracing. (Optional: does  $\alpha_i = \alpha_r$ ?)
2. Refraction. Use semicircular PSSC tanks to trace light rays through water or glycerin. (Optional: calculate  $n$ .)
3. Diffraction. Use coated microscope slide with razor blade scratches to observe diffraction. Which is diffracted more, red light or blue light? (Optional: calculate  $\lambda$ .)
4. Polarized light. Observe crumpled cellophane, Scotch tape and crystals between crossed polaroids. See activities in Student Handbook.
5. Particle refraction. Ball is rolled obliquely across two levels of paper. Ball "refracts" as it speeds up. (This is a PSSC experiment.)
6. Scattering. Milk is placed in water and scattering is observed. See activities in Student Handbook.

#### Day 2

Film: "Speed of Light" PSSC #0203 (21 min.)

Teacher presentation: History of Measurement of Velocity of Light. Include Roemer's method, Fizeau's toothed wheel, Michelson's method

#### Day 3

Small-group discussion: Is Light a Particle or a Wave?

Students discuss dual nature of light as seen in lab block of Day 1. After 15 minutes, assemble class and allow them to compare arguments. It is not necessary to form definite conclusions, as this point is discussed again in Unit 5.

#### Day 4

Teacher demonstration or student demonstration: Energy and light

Here are some possibilities:

1. hold wire in flame (incandescant)
2. spark discharge in air (high pressure discharge)
3. spark discharge in capillary tube (low pressure discharge)
4. Chemo luminescence (Welch #3735 \$2.00)

5. fluorescence under ultraviolet light
6. fluorescence by electron bombardment (Crookes tube or CRO)
7. flint and steel
8. hand generator from old telephone and neon tube
9. strip cellophane tape; as it separates, a very dim light is emitted (not a class demonstration)
10. spinthariscopes

#### Day 5

Teacher demonstration: Static Electricity

What you can do varies with what equipment is available, but some properties you can show are:

1. charging by induction and by contact
2. conductors and insulators
3. electroscopes
4. storing charges (capacitance)
5. point discharges

#### Day 6

Experiment 34: Coulomb's Law

An alternate to this experiment is the film "Coulomb's Law," PSSC #0403 (30 min.)

#### Day 7

Teacher lecture: Current Electricity

Use demonstrations to supplement general discussion of currents, conductors, semiconductors, circuits, potential difference, etc.

#### Day 8

Student Activity Day

Students show electric generating devices that they have assembled. In some cases where it is difficult to show actual device (e.g., fuel cell), charts or drawing might be used. Some other possibilities—dynamo, magneto, Farady disc dynamo, thermocouples, photocells, fuel cells, Van de Graaff generator, Wimshurst machines, etc.

#### Days 9 and 10

Lab stations: Current Balances: Students do 3 stations each day.

1. Investigate force as a function of current in wire.
2. Investigate force as function of length of wire.
3. Investigate force as function of magnetic field strength, using permanent magnets and yokes.



## Multi-Media Schedule

4. Investigate force as a function of magnetic field strength using coils of wire to generate field.
5. Other demonstrations may be set up for display such as electric field plotters, iron oxide in clear plastic box, circuit boards, etc.
- 6.

Day 11

Teacher demonstration lecture: Electric Fields

Discuss fields in general, then describe electrical fields. Use appropriate demonstrations.

Day 12

Programs: Electrical Forces and Fields and Electrical Potential Energy OR Milliken Experiment (E40).

Day 13

Demonstration of Huggins Tube

Have interested students construct and demonstrate a Huggins tube or other cathode ray tubes. (See Activities, Student Handbook.) Display of vacuum tubes will complement the demonstrations.

Day 14

Lecture: Magnetic Fields

Use Transparencies T32 and T33 with demonstrations to show interactions between magnetic fields and moving charges.

Day 15

Film: Prelude to Power

This film presents the story of Michael Faraday, and how his work in electromagnetism led to the development of the dynamo.

Days 16 and 17

Library Research

Possible topic: Sociological Implications of Electricity and Magnetism

Students are to research some aspect of the topic, and prepare report to give in class on days 19 and 20. An interesting variation on this is to have students dramatize their presentations on record. Tapes are played for class (See Unit 4 Student Handbook.) Since time is limited, it might be wise to do this assignment in small groups, instead of individually.

Day 18

Teacher demonstration: Electromagnetic Machines.

Use samples of dc and ac motors and generators to show operation and construction. This is a good place to discuss electrical power distribution.

Days 19 and 20

Students make their presentations of library research to class.

Day 21

Teacher presentation and class discussion: Maxwell's Contribution to Science

See Unit 4 Teacher Guide Bibliography for resource material. Also see Project Physics Supplemental Unit on Maxwell.

Day 22

Lab stations: Electromagnetic Waves.

1. film loop  
Standing Electromagnetic Waves
2. properties of microwaves (D52), reflection and absorption
3. properties of microwaves polarization (D52)
4. short-wave radio demonstration (if available), CENCO 80435
5. modulation of microwaves (E38)
6. Reader: The Electronic Revolution, Clarke or
7. radiowaves displayed on an oscilloscope, or
8. turntable oscillators (E38) or
9. resonance coils (E38)

Day 23

PSSC Film: #0415 (33 min.) Electromagnetic Waves

Common behavior of electromagnetic radiation over a wide range of wavelengths is demonstrated.

Follow with class discussion on film.

Day 24

Class discussion: Existence of the Ether and the Michelson-Morley Experiment

Day 25

Small-group discussion: review of Unit 4

Day 26

Unit 4 exams

### Chapter 13 Schedule Blocks

Each block represents one day of classroom activity and implies a 50-minute period. The words in each block indicate only the basic material under consideration.

#### Chapter 13 Light

Read 13.1-13.3

Models explain light phenomena

Read 13.6

Post lab and/or problem Seminar

Read 13.4

Interference effects and the wave model

Read 13.7, 13.8

Propagation of light waves

Read 13.5 and E32\*

Lab - Young's experiment

Renew

Test

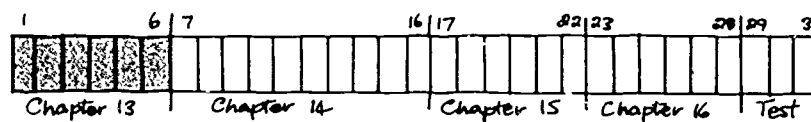

Chapter 13 Resources Chart

13.1	Introduction			
13.2	Propagation of light	1 4	2 3 5	
13.3	Reflection and refraction	6 9 10	8 12	7 11
13.4	Interference and diffraction	14	13 15	E32* Young's experiment
13.5	Color	16		
13.6	Why is the sky blue?			
13.7	Polarization		18 19	
13.8	The Ether		17	

Chapter 13 Resources Chart

T30 The speed of light

Looking into the eye

F30 Speed of light

Miscellaneous light activities

RA Velocity of Light

F31 Introduction to optics

Measuring index of refraction  
Matching index of refraction  
Making an ice lens

R3 Experiments and Calculations Relative to Physical Optics

Handkerchief diffraction grating  
Seeing and photographing diffraction patterns

Color vision by contrast (land effect)  
Properties of the human eye

Poisson's spot  
How to half-silver a mirror

R5 Popular Applications of Polarized Light

Polarized light activities

Miscellaneous photography activities  
The camera Does lie!

## Chapter 13 Experiment Summaries

### E32: Young's Experiment—Measuring the Wavelength of Light

Students observe and measure the interference pattern formed by a double-slit source. By using colored filters they can obtain values for the wavelength of light of these colors. Suggestions for observations of other diffraction and interference effects are made in the student notes.

#### Equipment

For each student group (at least six in each section).

- straight filament light source
- double slit on film
- pair of telescoping tubes, wooden block, rubber bands
- black tape
- Scotch tape ("magic transparent," not the clear type)
- 10X eyepiece and scale
- meter stick or mm ruler
- red, green, blue filters

### Chapter 14 Schedule Blocks

Each block represents one day of classroom activity and implies a 50-minute period. The words in each block indicate only the basic material under consideration.

#### Chapter 14 Electricity and Magnetic Fields

Read 14.1-14.3

Relationship of charge to force

Read 14.9, 14.10

Currents and circuits

Read 14.4 and 34

Lab - electric forces - Coulomb's law

Read 14.11, 14.12

Relating electric and magnetic forces

Read 14.5

Post lab and/or problem seminar

Read 14.13 and E37

Lab - electron-beam tube

Read 14.6

A closer look at electric charges

Post-lab and/or problem seminar

Read 14.7, 14.8

Moving charges

Review

Test

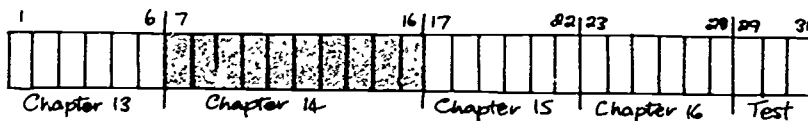

Chapter 14 Resources Chart

14.1	Introduction				E 33	Electric forces I
14.2	The curious properties of lodestone and amber					
14.3	Electric charges and electric forces	1 2 3 4			D47	Electrostatic demonstrations
14.4	Forces and fields	7 9	6 8	5	E34	Electric forces - Coulomb's law
14.5	The smallest charge	10 11	12	13		
14.6	Early research with electric charges	14			D48	The electrophorus
14.7	Electric currents					
14.8	Electric potential difference	15 16 17	18 19 20			
14.9	Electric potential difference and current	21				
14.10	Electric potential difference and power	25	22 23 24			
14.11	Currents act on magnets	26	27 28		D49 E35	Currents and forces Currents and forces
14.12	Currents act on currents				D50 E36	Currents, magnets and forces Currents, magnets and forces
14.13	Magnetic fields and moving charges.	29 30 32		31	E37	Electron-beam tube

Chapter 14 Resources Chart

R6 Action at a Distance

T31  $\vec{E}$  field inside  
conducting sphere

F32 Coulomb's law

Demonstrating electric fields  
Demonstration of electric fields  
in three dimensions

An 11¢ battery  
Voltaic pile

More perpetual motion machines

T33 Forces between  
current carriers

Force law for bar magnets

Who's who in TV

T32 Magnetic Fields and Moving Charges  
F33 Electrons in a Uniform Magnetic Field  
R16 Radiation Belts Around the Earth

Measuring magnetic field intensity  
Additional activities using the  
electron-beam tube



## Chapter 14 Experiment Summaries

### Summary of Experiment 33\*. Electric Forces I

A length of Scotch tape is charged by being stuck to a table and then peeled off. This strip is suspended and used to detect and classify (attraction or repulsion) the charge on other objects—strips of tape, rubber plastics, rubber, etc. Students should be able to conclude that matter can be charged in only two possible ways. The attraction between a charged object and an uncharged one is left as a puzzle for the students.

#### Equipment

Scotch tape ("magic transparent" type) preferably in a dispenser  
table stand and horizontal rod  
variety of plastic strips, rubber rods, cloth, cat's fur, etc.

### Summary of Experiment 34 Electric Forces II — Coulomb's Law

The experiment gives students direct experience with an inverse-square force law. Several methods could be used to measure the small forces involved. The soda-straw balance used in this experiment does not require indirect geometrical calculations. The same lever principle will be used later in current balance and electrolysis experiments. As students do the experiment they have a real and obvious sense that they are measuring forces.

They should find that  $F \propto \frac{1}{d^2}$ , and, in an extension to the experiment, that  $F \propto q_1 q_2$ .

#### Equipment

For each student team (the "Electrostatics Kits" produced for the PSSC course—e.g., Macalaster Scientific #1001, are a convenient source of many of these items):

1 soda straw  
2 coated polyfoam or pith spheres  
2 plastic slivers  
1 balance support  
2 straight pins  
about 15 cm wire, #30 copper  
forceps  
4 × 6 inches (approximately) file card or pad  
1 ring stand with test tube clamp  
plastic strip and cloth for charging spheres  
ruler

#### For general use:

wire cutters (scissors will do)  
knife or razor for cutting notches  
glycerine, mineral oil or vacuum pump oil, about 10 cc per unit  
some materials for measuring distances  
tape—double stick if possible

### Summary of Experiment 35\*. Currents and Forces

Students first do a brief qualitative investigation of the interaction between a magnet and a current. This is to familiarize them with the equipment, it also follows the order in which the topics are developed in the

In the main part of the experiment students investigate the force between two parallel current-carrying conductors.

There are three combinations of variable to be studied: force as a function of the current in one of the wires; force as a function of the distance between the wires; force as a function of the length of one of the wires. It is suggested that the class be divided into three groups, each to study one of the combinations.

#### Equipment

##### A. Force as a function of current

1 current balance, with the longest magnesium loop\*  
1 power supply, 0-8 v dc  
about 50 cm #30 copper wire

2 ammeters, 0-5 A dc  
2 rheostats, about 5 ohms, 5 amps  
1 ring stand and test tube clamp to hold zero indicator  
hook-up wire or clip leads  
forceps  
ceramic magnets

##### B. Force as a function of distance

Same as Group A, plus:

1 small mirror. Pressure-sensitive centimeter tape\* is stuck along one edge. This "anti-parallax" device is used for measurement of  $d$ , distance between wires.

##### C. Force as a function of length

Same as Group B, plus:

4 magnesium balance loops

### Summary of Experiment 36\* Currents, Magnets and Forces

From the first part of Experiment 35, and from Demonstration 49 it is clear that when a current is in a magnetic field, there is a force on the current.

In this set of three experiments, students make measurements of this force. One group of students investigates the variation of force with current, another investigates how the force varies with the length of the magnetic field, and the third group measures the strength of the earth's magnetic field.

#### Equipment

A. 1 current balance, with longest loop  
1 power supply, 6-8 v dc  
1 variac or 1 rheostat, 5 ohms, 5 amps  
1 ammeter 0-5 A dc  
2 ceramic magnets, iron yoke  
wire leads  
50 cm of #30 copper wire  
forceps

##### B. Same as Group A plus:

2 additional iron yokes, enough ceramic magnets so that a total of 3 matched pairs can be found. If more than 3 pairs are possible, so much the better.

##### C. Same as Group A—but no magnets: It is possible that students will prefer a thinner wire than the #30 copper. They can then use longer length. For example, 5 cm of #37 copper weighs about the same as 1 cm of #30.

### Summary of Experiment 37 Electron Beam Tube

Students assemble simple electron beam tubes (this could be done at home). With standard laboratory vacuum pump and power supplies the tube should give a beam several centimeters long that is made visible by ionization of the residual air in the tube. Students can observe the deflection of the electron beam in electric and magnetic fields, operating principle of television picture tubes and cathode-ray tubes.

#### Equipment

##### For assembly:

electron beam tube kit  
silicone rubber sealant  
wire cutters

##### At operating station:

vacuum pump  
power supplies:  
a) about 6V, 5A with 5 $\Omega$ , 5A rheostat and ammeter, for filament  
b) about 100V dc for anode, with higher and/or lower voltage taps for deflection plate.  
hook-up wire  
magnets and yoke (from current balance)

### Chapter 15 Schedule Blocks

Each block represents one day of classroom activity and implies a 50-minute period. The words in each block indicate only the basic material under consideration.

#### Chapter 15 Faraday and the the Electrical Age

Read 15.1-15.3

Investigating  
the electric  
field

problem  
seminar

Read 15.4

Magnets  
and  
currents

Read 15.8-15.9

Science  
and  
civilization

Read 15.5-15.7

Electro-  
magnetism  
put to use

Review

Test

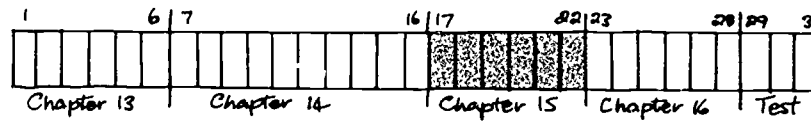

Chapter 15 Resources Chart

15.1 The problem. getting energy from one place to another	1 2		
15.2 Clue to the solution. electromagnetism			
15.3 Faraday's early work on electricity and lines of force	3	4	D51 Electric fields
15.4 The discovery of electromagnetic induction		20	
15.5 Generation of electricity from magnetism. the dynamo		20	
15.6 The electric motor		5 6 7 8 9	
15.7 The electric light bulb	10	11	
15.8 Ac versus dc and the Niagara Falls power plant	13 14 15 16 17	12	
15.9 Electricity and Society	19	18	

Physics collage

R2 On the Method of  
Theoretical Physics

The lodestone, the magnet

R14 Relationship of  
Electricity and  
Magnetism

T32 Magnetic fields and  
moving charges

Faraday disc-dynamo  
Bicycle generator  
Generator jump rope

T32 Magnetic fields and  
moving charges

Simple meters and motors  
Simple motor-generator demonstration

R8 The Invention of the  
Electric Light

R10 Future of Direct  
Current Power  
Transmission

R7 The Electronic Revolution

R9 High Fidelity

R17 A Mirror for the Brain

R1 Letters from Thomas Jefferson, June 1799.

Epicyles on the oscilloscope

## Chapter 16 Schedule Blocks

Each block represents one day of classroom activity and implies a 50-minute period. The words in each block indicate only the basic material under consideration.

### Chapter 16 - Electromagnetic Radiation

Read 16.1-16.2

Discussion  
of Maxwell's  
waves

Read 16.5-16.7

Maxwell-  
applications  
and  
implications

Read 16.3-16.4

Electro-  
magnetic  
waves and  
light

Review

Chapter  
test

Read E38

Lab -  
waves,  
modulation,  
communica-  
tion

Unit  
review

Post-lab  
and/or  
problem  
seminar

Unit  
test

Go over  
unit test

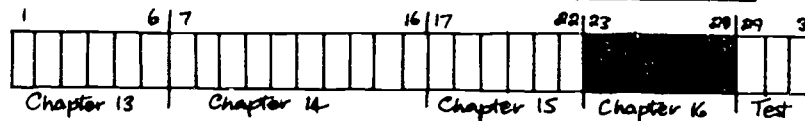

Chapter 16 Resources Chart

16.1	Introduction	1		
16.2	Maxwell's formulation of the principles of electromagnetism	2		
16.3	The propagation of electromagnetic waves	4	3 5	D5a Microwaves
16.4	Hertz's experiments	7	6 8	E38 Waves, modulation, communication
16.5	The electromagnetic spectrum	9 10 11 13 19,22	12 14 15 17 18 20,21	16
16.6	Maxwell: intellectual characteristics and attitudes	23	24 25 26 27	
16.7	What about the ether?		28	

Science stamps

R13 On the Induction of  
Electric Currents

L41 Standing electromagnetic  
waves  
F34 Electromagnetic waves  
R15 Electromagnetic Field

A recorded research report

T34 The electromagnetic  
spectrum

Looking inside a radio tube

R11 James Clerk Maxwell-  
Part II

Bell Telephone science kits

R12 Collection of Maxwell's  
Letters

R18 Scientific Imagination

Good reading

## Chapter 16 Experiment Summaries

### E38\*: Waves, Modulation, Communication

After a series of demonstrations using turntable oscillators, coil-capacitor circuits and microwave equipment, students experiment with the same equipment. Although the student notes suggest some investigations not covered in the demonstration, they can quite profitably repeat the demonstrations for themselves either before beginning the new work, or instead of it.

#### Equipment

##### A. Turntable Oscillators

pair of turntable oscillators  
"Pentel" pen  
recording paper  
masking tape for adjusting fit of pen in slot  
ruler for measuring traces

##### B. Resonant Circuits

pair of resonant (coil capacitor) circuits  
amplifier  
oscillator  
cathode-ray oscilloscope  
loudspeaker  
hook-up wire

##### C. Microwaves

microwave generator  
(2) amplifier/power-supply units  
diode detector  
100  $\mu$ A meter  
oscillator  
(microphone)  
loudspeaker



Brief Answers to Unit 4 Study Guide

Chapter 13

- 13.1 7.5 cm
- 13.2 (a) distance too small  
(b) no  
(c) large distances involved  
(d) lower limit was achieved
- 13.3 (a)  $4.4 \cdot 10^4$  m  
(b)  $3.0 \cdot 10^4$  m/sec  
(c) conjunction cycle
- 13.4  $9.5 \cdot 10^{11}$  m
- 13.5 4.3 yrs.: 28 times
- 13.6 path shown
- 13.7 36"
- 13.8 invisible
- 13.9 diagrams
- 13.10 (a) diagram  
(b) inverse with height
- 13.11 (a) diagram  
(b)  $\frac{1}{2}mv^2$ ;  $mv_x^2 = mv^2 \sin^2 \theta$   
 $mv_y^2 = mv^2 \cos^2 \theta$   
(c)  $\frac{1}{2}mv^2$  and  $mv_x^2$   
(d) energy conservation  
(e)  $mv_x^2 = mv^2 \sin^2 \theta$ ;  $mv_y^2 = mv^2 \cos^2 \theta$   
(f) derivation
- 13.12 diagrams
- 13.13 (a)  $(m + \frac{1}{2})\lambda$   
(b) red  
(c) increased fringe separation  
(d) same as (c)  
(e) same separation
- 13.14 appears in bright fringes
- 13.15 constructive interference
- 13.16  $6 \cdot 10^{14}$  cps;  $10^{11}$  times AM
- 13.17 (a) no  
(b) discussion
- 13.18 discussion
- 13.19 discussion

Chapter 14

- 14.1 (a) tripled  
(b) halved  
(c) not changed
- 14.2 95 km
- 14.3 discussion
- 14.4 yes; positive
- 14.5 (a) 1.6 N/kg  
(b)  $4.1 \cdot 10^9$  N/kg  
(c)  $g_r \propto r$

- 14.6 reaction to field, then to source
- 14.7 (a) right  
(b) down
- 14.8 (a) 10 coulombs  
(b)  $10^{-11}$  coulombs/m
- 14.9 sketch (normal to surfaces)
- 14.10 help
- 14.11  $6.25 \cdot 10^4$  electrons
- 14.12  $3.4 \cdot 10^{11}$
- 14.13 (a)  $\frac{1}{2}mv^2 = \frac{1}{2}kq^2/R$   
(b)  $1.2 \cdot 10^{-18}$  J  
(c)  $1.5 \cdot 10^4$  m/sec
- 14.14 conductor
- 14.15 30 volts
- 14.16 zero
- 14.17 derivation
- 14.18 (a)  $3 \cdot 10^4$  volt/meter  
(b)  $10^7$  volt/meter
- 14.19 (a) 12 volts  
(b) zero  
(c) 12 volts
- 14.20 (a) 100 eV or  $1.6 \cdot 10^{-17}$  J  
(b)  $5.6 \cdot 10^8$  m/sec.
- 14.21 (a) 4 amps  
(b) 5 ohms  
(c) 15 volts
- 14.22 (a)  $10^7$  volts  
(b)  $5 \cdot 10^8$  joules
- 14.23 discussion
- 14.24 20 watts
- 14.25 (a) 8 watts  
(b) 20 watts  
(c) 40 watts
- 14.26 compass can't respond
- 14.27 north
- 14.28 3 amps north
- 14.29 (a) derivation  
(b) v, B and F
- 14.30 derivation
- 14.31 (a) derivation  
(b) discussion
- 14.32 west

Chapter 15

- 15.1 discussion
- 15.2 yes
- 15.3 all except (d)
- 15.4 discussion
- 15.5 (a) exercise  
(b) upward  
(c) downward

**Study Guide**  
**Brief Answers**

- 15.6 Lenz's law  
15.7 outside magnet  
15.8 opposite  
15.9 discussion  
15.10 (a) 1 amp  
(b) 10 ohms  
(c) burn out  
15.11 (a) 1/12 amp  
(b) 1440 ohms  
15.12 (a) 1 amp,  $\frac{1}{2}$  amp  
(b) 1/5 watt, 1/20 watt  
(c) 0.97 amp, 0.19w, 5.6w;  
0.50 amp, 0.05w, 6w.  
15.13 5 amps  
15.14 derivation  
15.15 low voltage coil  
15.16 discussion  
15.17 discussion  
15.18 report  
15.19 discussion  
15.20 sketch
- 16.23 discussion  
16.24 discussion  
16.25 unnecessary for math. description  
16.26 discussion  
16.27 discussion  
16.28 body: mechanical models  
grin: mathematical description

**Chapter 16**

- 16.1 symmetry  
16.2 no  
16.3 accelerating charge, mutual induction.  
16.4 (a) height  
(b) pressure  
(c) field strength  
16.5 measurement uncertainty  
16.6 detector orientation  
16.7 light properties  
16.8 discussion  
16.9 absorption effects, etc.  
16.10  $5 \times 10^6$  m  
16.11 10 m to  $10^2$  m  
16.12 frequency modulated  
16.13 discussion  
16.14 discussion  
16.15 ionospheric reflection of shorter wavelength radiation  
16.16 27,900 miles  
16.17 phase difference between direct and reflected waves  
16.18 AM; FM  
16.19 2.6 sec.  
16.20 absorption  
16.21 evolution  
16.22 UV and IR

Solutions to Chapter 13 Study Guide

13.1

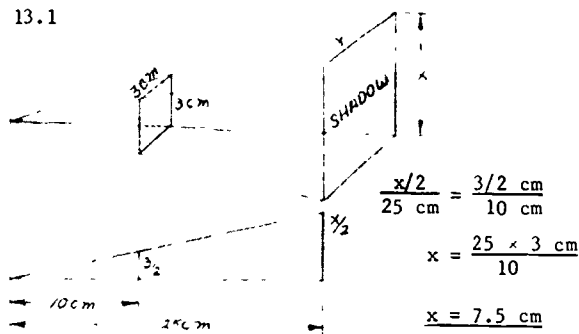

13.2

a) Galileo was unsuccessful because the distance he used was far too short to detect any delay in arrival of the light signal. If the distance had been even 3 km in total, light would travel that distance in a time of

$$\frac{3 \times 10^3 \text{ m}}{3 \times 10^8 \text{ m/sec}} = 10^{-5} \text{ sec.}$$

much too small a time delay to detect by his method.

b) It is not possible that at Galileo's time anyone could have detected a delay in the time of arrival of a light signal sent between two points on earth. If we assume that a detectable delay time would be in the order of 1/5 sec, then the round-trip distance necessary would be  $1/5 \text{ sec} \times 3 \times 10^8 \text{ m/sec} = 6 \times 10^7 \text{ m}$  or  $6 \times 10^4 \text{ km}$ .

c) Celestial observations can involve very large distances and therefore the corresponding time difference resulting from the finite speed of light can be easily detected and measured accurately.

d) Suppose the longest time that light might have taken in getting from one observer to the other without the observers detecting the delay was 1/2 sec for the round trip of approximately 3 km. We could then conclude that the speed of light cannot be less than 6 km/sec. Thus, Galileo's experiment did show a lower limit for the speed of light.

13.3

a) In  $1 \frac{3}{4}$  days the earth makes  $\frac{1.75}{365}$  of a revolution. Therefore, the distance traveled in that time =  $\frac{1.75}{365} \times 2\pi \times 1.5 \times 10^{11} \text{ m}$   
 $= 4.4 \times 10^9 \text{ m}$

b) If the earth traveled  $4.4 \times 10^9 \text{ m}$  directly away from or toward Jupiter, then the 15 seconds represents the time required for light to travel that distance. Therefore, the speed of light =  $\frac{4.4 \times 10^9 \text{ m}}{15 \text{ sec}} = 3.0 \times 10^8 \text{ m/sec}$ .

c)

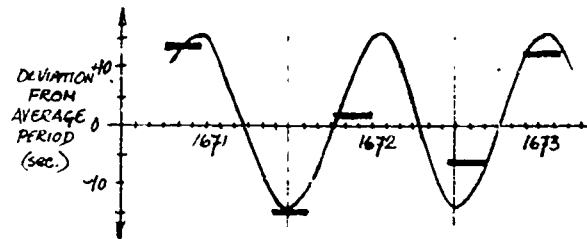

The curve can be seen to repeat itself after a little more than one year (actually 12/11 of a year—computing this value is similar to calculating how many hours after midnight the hands of a clock again coincide). The cycle, of course, represents the apparent differences in period of Io as seen from the earth in the time taken for the earth to move from one conjunction with Jupiter to the next.

13.4

One light year

= speed of light in m/sec  $\times$  number of seconds in one year.

Number of seconds in one year

$$= 60 \frac{\text{sec}}{\text{min}} \times 60 \frac{\text{min}}{\text{hr}} \times 24 \frac{\text{hr}}{\text{day}} \times 365 \text{ days}$$

$$= 3.16 \times 10^7 \text{ sec. Therefore one light year}$$

$$= 3.0 \times 10^8 \frac{\text{m}}{\text{sec}} \times 3.16 \times 10^7 \text{ sec}$$

$$= 9.5 \times 10^{15} \text{ m.}$$

13.5

To travel 4.3 light years at the speed of light requires, by definition, 4.3 years. At only 1/1000 of the speed of light, the trip one-way would take 4,300 years. The speed given is 300 km/sec. This is  $300/11 = 28$  times as fast as the rocket bound for Venus.

13.6

The shortest path from A to B via the mirror is the path shown (each half of which by Pythagoras' theorem must be 5 cm). Any other path is longer than 10 cm in total. Light follows a path such that the angles of incidence and reflection are equal. Only the 10 cm path shown has this property. We see then that light follows the path from A to M to B that requires the least time (light always travels by least-time paths).

Study Guide  
Chapter 13

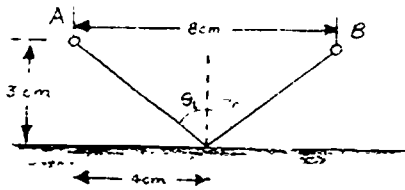

13.7

To calculate the height of mirror required, we need to consider the path taken by light rays from his feet to the mirror and then to his eyes. Also consider light from the top of his head to the mirror and then to his eyes. Assume his eyes are 6" from the top of his head. Any reasonable distance from the mirror is satisfactory. The solution of the problem depends on the equality of the angles of incidence and reflection, which is independent of the distance from the mirror.

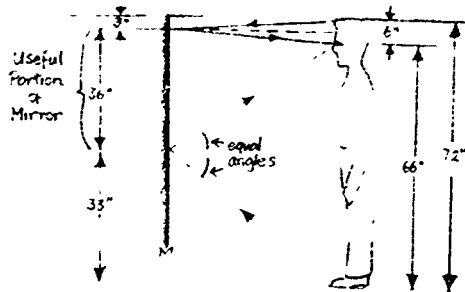

The distance from his eyes to the top of his head is not important either, as can be seen from the second diagram.

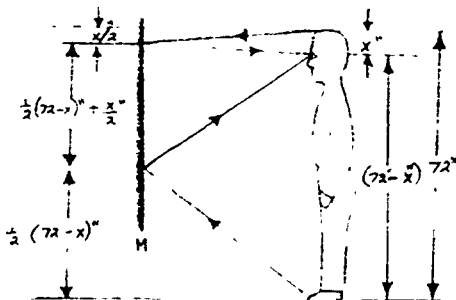

The effective mirror length is  
 $\frac{1}{2}(72 - x)'' + \frac{x''}{2} = 36'' - \frac{x''}{2} + \frac{x''}{2} = 36''.$

13.8

If the reflecting surfaces of visible objects changed so that they completely absorbed any light falling on them, they would no longer be visible. The only things visible under such conditions would be actual sources of light. The world would not in fact "appear" at all—only light sources would "appear."

13.9

a)

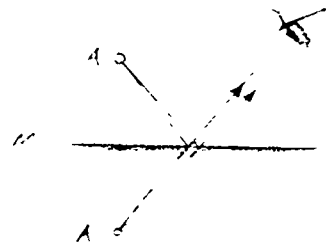

b)



c)

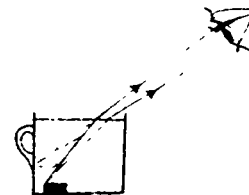

13.10

a) Light entering the atmosphere at a near-grazing angle is shown refracted into the atmosphere in a slight curve. Thus the light received at sunset or sunrise did not come in a "straight line" from the sun, the sun being "below" the horizons.

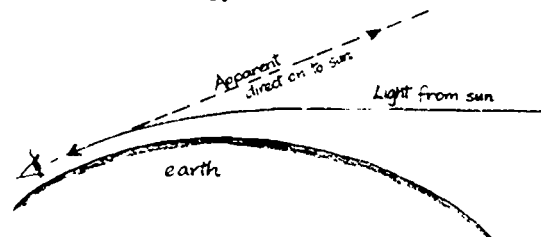

b) This atmospheric refraction indicates that the earth's atmosphere is more dense at lower altitudes.

13.11

a)

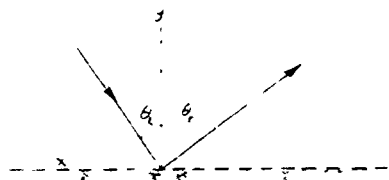

b) Kinetic energy of a single particle =  $\frac{1}{2}mv^2$ .

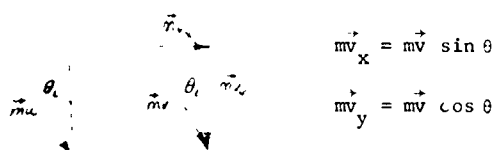

c) Since no work is done on the particle, kinetic energy is conserved. The x-component of the momentum is also conserved since no force acted in that direction; however, the y-component of momentum is not conserved.

d) Since energy is conserved, kinetic energy of incident particle = kinetic energy of reflected particle.  $\frac{1}{2}mv^2 = \frac{1}{2}mu^2$ . Therefore,  $v = u$  (strictly speaking  $v = \pm u$ , but the negative sign has no significance here).

e)

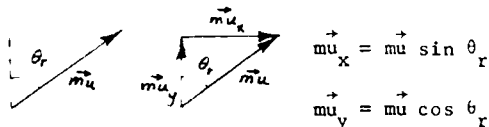

f) Since the x-components of the momentum are equal before and after collision,

$$\begin{aligned} \vec{mv}_x &= \vec{mu}_x \\ m\vec{v} \sin \theta_i &= m\vec{u} \sin \theta_r \text{ but } u = v \text{ [from part (d)]} \\ \therefore \sin \theta_i &= \sin \theta_r \\ \text{thus } \theta_i &= \theta_r \end{aligned}$$

13.12

We can represent the velocity of the incident particle by a vector  $\vec{v}$  at angle  $\alpha$  to the y-axis and the velocity of the reflected particle by a vector  $\vec{u}$  at angle  $\beta$  to the y-axis. These two vectors must have the same x-component because no force acts in the x direction, but the y component of  $\vec{u}$  will be greater than the y component of  $\vec{v}$  because of the action of the accelerating

force. Therefore, we proceed by drawing a vector  $\vec{u}$  equal  $\vec{v}$ . Then from the tail of vector  $\vec{u}_x$ , we draw a line at angle  $\beta$  to the vertical, allowing it to intersect a vertical line dropped down from the head of  $\vec{u}_x$ . We have thus mechanically constructed vectors representing  $\vec{u}_y$  and  $\vec{u}$ .

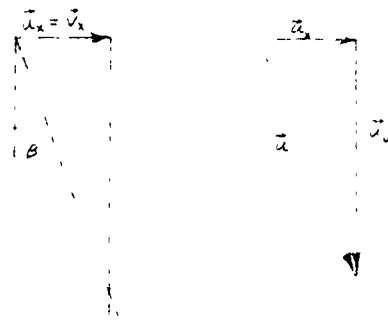
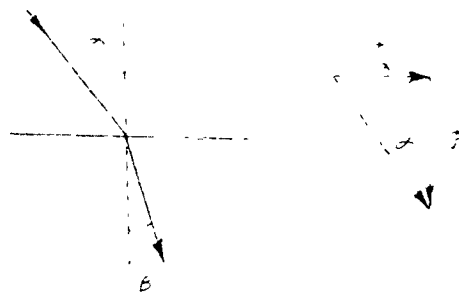

13.13

a) Destructive interference occurs if the path difference =  $(m + 1/2)\lambda$ , where  $m = 0, 1, 2, 3, \dots$

b) The separation of the fringes is greater for red light than for blue light because the wavelength and hence the corresponding path difference is greater for red than blue.

c) Increasing the distance to the screen results in increased separation of the fringes (actually, they are directly proportional).

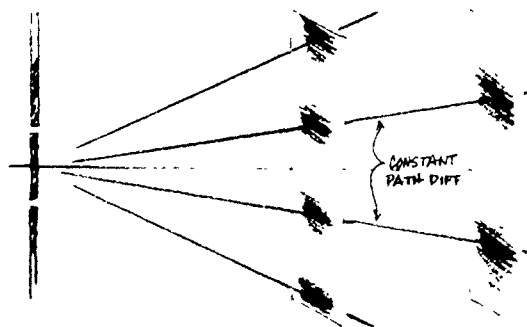

Study Guide  
Chapter 13

d) The separation of the fringes becomes greater as the slits are moved closer together.

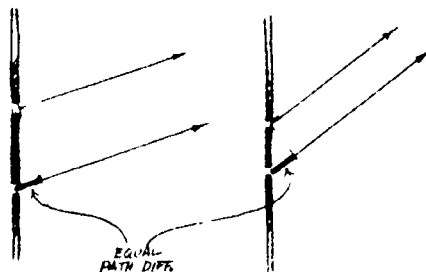

e) Narrowing each slit results in more diffraction and consequently an interference pattern consisting of brighter fringes but the separation of the fringes remains unchanged.

---

13.14

There is no loss of energy in an interference pattern: the energy which is not apparent in the dark fringes actually appears in the bright fringes.

---

13.15

Diffraction occurs around the disk. Since all points along the center of the shadow are equidistant from the light source and the edge of the disk, constructive interference occurs between the diffracted waves. Hence, there is a bright spot on the screen in the center of the shadow.

---

13.16

In general, frequency =  $\frac{\text{speed}}{\text{wavelength}}$ . For green light, frequency =  $\frac{3 \times 10^8 \text{ m/sec}}{5 \times 10^{-7} \text{ m}} = 6 \times 10^{14} \text{ /sec}$ . This is often referred to as  $6 \times 10^{14} \text{ /cycles/sec}$ .

The frequency of the normal (AM) radio broadcasting range is from 54 kilocycles/sec to 160 kilocycles/sec (i.e., from  $5.4 \times 10^4 \text{ cycles/sec}$  to  $16 \times 10^4 \text{ cycles/sec}$ ).

The FM broadcasting range is from 88 megacycles/sec to 108 megacycles/sec (i.e., from  $8.8 \times 10^7 \text{ cycles/sec}$  to  $10.8 \times 10^6 \text{ cycles/sec}$ ).

Thus the frequency of green light is approximately  $10^{10}$  times that of AM radio frequencies, and  $10^7$  times that of FM radio frequencies.

13.17

a) The poet Richard Savage cannot be classified as a "nature philosopher." In fact his poem The Wanderer is apparently a poetic interpretation of Newton's theory of color.

b) Probably Richard Savage has a better understanding of physics than James Thomson, but it is difficult to judge on the basis of only one poem. Judging which is the better poem is another matter; for most persons the accuracy of the science content would not be a major criterion.

---

13.18

Suppose the windows of apartment A had polarizing sheets over the glass with the polarizing axis vertical, and apartment B had the sheets oriented with the axis horizontal. Then both apartments would receive light from the courtyard and the sky above but light would not be able to travel from apartment A into apartment B or vice versa.

---

13.19

Suppose every vehicle had polarizing sheets over the windshield and headlights, with the polarizing axis oriented at a  $45^\circ$  angle from the lower left to the upper right as viewed by the driver. Consider light from headlights of an approaching car: in passing through the polarizing sheet over the headlights it becomes polarized in a plane that is at a  $90^\circ$  angle to the polarizing axis on the windshield of the other car. Hence, the light would be blocked and the drivers of both cars would view the highway without being blinded by glare. Due to imperfections in the polarizing sheets and the action of dust on headlights and windshields the drivers would be able to see the other car's headlights, but only dimly.

Solutions to Chapter 14 Study Guide

14.1

- a) The distance must be tripled.
- b) The distance must be halved.
- c) The distance must not be changed.

14.2

$$F_{e1} = \frac{kq_A q_B}{R^2}$$

$$R^2 = \frac{kq_A q_B}{F_{e1}} = 9 \times 10^9 \frac{N \cdot m^2}{(Coul)^2} \times \frac{1C^2}{1N}$$

$$R^2 = 9 \times 10^9 m^2 = 90 \times 10^8 m^2$$

Therefore,  $R = 9.5 \times 10^4 m$  or 9.5 km

14.3

The separation of charge occurs in such a way that one side of the object will be positive and the other negative. The difference in distance between these two concentrations of charge and the charging body results in a net force of attraction.

14.4

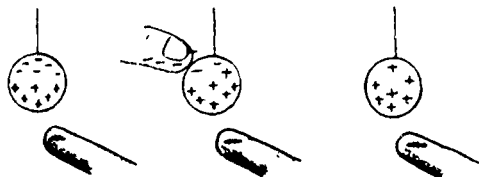

Negative charges are repelled into the finger when it touches, leaving the ball positively charged.

14.5

$$a) \quad g = \frac{GM}{r^2} = \frac{(6.67 \times 10^{-11} \frac{Nm^2}{kg^2})(7.3 \times 10^{22} kg)}{(1.74 \times 10^6 m)^2} = 1.6 \frac{N}{kg}$$

b) The mass of the star is  $M = (\text{density})(\text{volume}) = (\text{density})(\frac{4}{3}\pi r^3)$ .

$$= (10^{11} \frac{kg}{m^3})(\frac{4}{3})(3.14)(1.5 \times 10^6 m)^3 = 1.4 \times 10^{30} kg.$$

The field at the surface is

$$g = \frac{GM}{r^2} = \frac{(6.67 \times 10^{-11} \frac{Nm^2}{kg^2})(1.4 \times 10^{30} kg)}{(1.5 \times 10^6 m)^2}$$

$$g = 4.1 \times 10^9 \frac{N}{kg}$$

c) Assume a uniform density  $D$  for the earth, so that the mass inside a sphere of radius  $r$  is

$$M_r = \frac{4}{3}\pi r^3 D.$$

At a distance  $r$  from the center, the effect of all matter outside a sphere of radius  $r$  would cancel out. The field due to the matter inside  $r$  is

$$g_r = G \frac{M_r}{r^2} = G \frac{\frac{4}{3}\pi r^3 D}{r^2} = (\frac{4}{3}\pi G D)r$$

Thus a gravitational field inside a homogeneous earth would increase in direct proportion to the distance from the center.

Actually the earth is several times more dense in the middle than near the surface; moving closer to the dense core overcompensates the amount of material left outside, and the field strength increases for some distance into the earth.

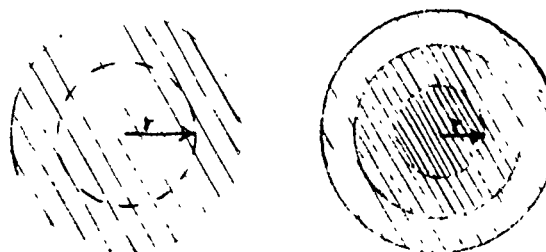
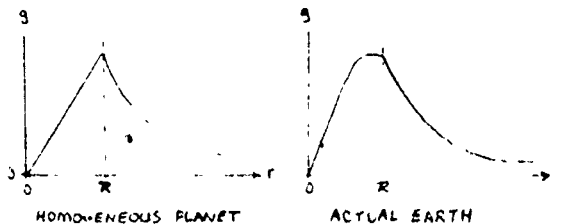

The case for the actual earth is rather complicated. However, some students might enjoy taking average values for core and mantle, make separate graphs for the fields due to each, and add them to make a rough graph of total field against  $r$ .

Study Guide  
Chapter 14

14.6

An equal but oppositely directed force must be experienced by the field (but since the field is the connection between the charged particle and the source of the field, the source of the field also experiences the reaction force).

14.7

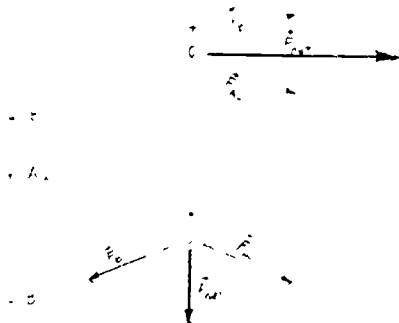

14.8

a) The formula for the electric field strength of a spherically symmetrical charge is  $E = kQ/r^2$ . In the MKS system of units that uses volts and coulombs, the value of  $k$  is about  $10^{10}$ . The radius of the earth is about  $10^7$  meters. If the field strength at the surface is  $10^2$ , then

$$10^2 = \frac{10^{10} Q}{(10^7)^2}$$

$$Q = \frac{10^{14} \times 10^2}{10^{10}}$$

$$= 10^6 \text{ coulombs.}$$

b) The formula for the surface area of a sphere is  $4\pi r^2$ . For the earth, this is roughly  $10 \times (10^7 \text{ m})^2 = 10^{15} \text{ m}^2$ . If  $10^6$  coulombs of charge is distributed over  $10^{15}$  square meters, the average charge density would be  $10^{-9}$  coulombs per square meter. Common static charges on combs, people, etc., are something like  $10^{-9}$  coulombs. So  $10^{-9}$  coulombs/m is a fairly small static charge.

14.9

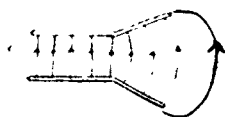

14.10

Air friction is a help because it makes a small charged body stop moving if the electric force and gravitational force on the body are balanced. When the body stops moving the air friction becomes zero and the only forces then acting are electric and gravitational, which are then known to be equal.

14.11

Call  $n$  the number of electrons required for one coulomb of charge. Then

$$n \times 1.6 \times 10^{-19} \text{ coul/electron} = 1 \text{ coulomb}$$

$$n = \frac{1}{1.6 \times 10^{-19}} \text{ electron} = 6.25 \times 10^{18} \text{ electrons}$$

14.12

$$\frac{F_{el}}{F_{grav}} = \frac{k \frac{q^2}{R^2}}{G \frac{m^2}{R^2}} = \frac{kq^2}{Gm^2} = \frac{k}{G} \left(\frac{q}{m}\right)^2$$

Therefore,

$$\frac{F_{el}}{F_{grav}} = \frac{9 \times 10^9 \text{ N}\cdot\text{m}^2/\text{C}^2}{6.7 \times 10^{-11} \text{ N}\cdot\text{m}^2/\text{kg}^2} \left(\frac{1.6 \times 10^{-19} \text{ C}}{10^{-30} \text{ kg}}\right)^2$$

$$= 3.4 \times 10^{42}$$

14.13

$$a) \frac{mv^2}{R} = \frac{kq^2}{R^2}; \text{ thus, } mv^2 = \frac{kq^2}{R}$$

and the KE,  $\frac{1}{2}mv^2 = \frac{1}{2} \frac{kq^2}{R}$

$$b) KE = \frac{1}{2} \frac{kq^2}{R}$$

$$= \frac{1}{2} \times 9 \times 10^9 \frac{\text{N}\cdot\text{m}^2}{\text{C}^2} \times \frac{(1.6 \times 10^{-19} \text{ C})^2}{10^{-10} \text{ m}}$$

$$= 4.5 \times 10^9 \times 2.56 \times 10^{-38} \times 10^{10} \text{ N}\cdot\text{m}$$

$$= 11.6 \times 10^{-19} \text{ joules}$$

$$= 1.2 \times 10^{-18} \text{ joules}$$

(to two significant figures)

$$c) \frac{1}{2}mv^2 = KE; \text{ thus, } v = \sqrt{\frac{2KE}{m}}$$

$$v = \sqrt{\frac{2 \times 1.2 \times 10^{-18} \text{ N}\cdot\text{m}}{10^{-30} \text{ kg}}}$$



$$= \sqrt{2.4 \times 10^{-2} \frac{\text{m}^2}{\text{sec}^2}}$$

$$v = 1.5 \times 10^6 \text{ m/sec}$$

Note:  $\frac{\text{N} \cdot \text{m}}{\text{kg}} = \frac{\text{kg} \cdot \text{m}/\text{sec}^2 \cdot \text{m}}{\text{kg}} = \frac{\text{m}^2}{\text{sec}^2}$

14.14

A metal comb will not acquire a net charge because it is a good conductor and any charge is "grounded" by the person holding the comb—that is, any separation of charge occurring between the comb and the person's hair is immediately redistributed. However, if the comb were insulated from the hand by some material, then it could acquire a net charge.

14.15

The potential difference would be

$$\frac{6 \times 10^{-4} \text{ joules}}{2 \times 10^{-5} \text{ C}} = 30 \text{ joules/coul or } 30 \text{ volts}$$

14.16

The electric field in that region must be zero at all points.

14.17

One volt is one  $\frac{\text{joule}}{\text{coulomb}}$  or, since a joule is a newton-meter, one  $\frac{\text{newton-meter}}{\text{coulomb}}$ . Therefore, one  $\frac{\text{volt}}{\text{meter}}$  is one  $\frac{\text{newton-meter}}{\text{coulomb meter}} = \text{one } \frac{\text{newton}}{\text{coulomb}}$ .

The greater the electric field, the greater will be the electric force on a charged particle and so the greater will be the work done on it in moving through some distance. Thus, the greater the electric field, the greater the change of potential difference with distance. The rate of change of potential difference with distance (volts per meter) is a measure of the electric field strength (newtons per coulomb).

Another approach would be:

$$\begin{aligned} \text{Work} &= qEd \\ \text{Potential difference} &= \frac{\text{Work}}{q} \\ &= \frac{qEd}{q} \\ &= Ed \\ \text{So } E &= \frac{\text{potential difference}}{d} \end{aligned}$$

14.18

a) A potential difference of 30,000 volts across a distance of 1 cm implies an electric field strength in the gap of  $\frac{30,000 \text{ volts}}{.01 \text{ meter}} =$

3,000,000 volts/meter. In most cases the field wouldn't be uniform and so this would be an average value. The air between pointed electrodes 1 cm apart can break down when the potential difference between them is only about 10,000 volts, because the field is so intense near the points.



b) A potential difference of 10,000 volts across a distance of 1 mm implies an electric field in the gap of  $\frac{10,000 \text{ volts}}{.001 \text{ meter}} = 10,000,000$  volts/meter. Even in the small gap region the field wouldn't be uniform, so this value is only an average.

14.19

a) The potential at A is 12 volts higher than the potential at D.

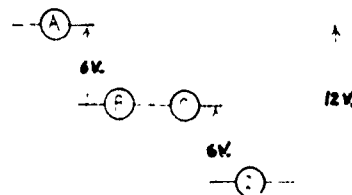

b) The potential of the terminal at the left is the same as the potential of the terminal at the right. Both are 6 volts above the middle terminals.

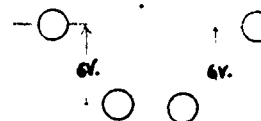

c) The potential of the terminal at the left is 12 volts higher than the potential of the terminal at the right.

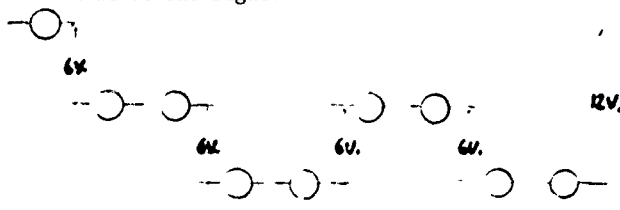

Study Guide  
Chapter 14

14.20

a) kinetic energy gained = 100 eV or  
 $100 \text{ eV} \times 1.6 \times 10^{-19} \text{ J/eV} = 1.6 \times 10^{-17} \text{ J}$

b)  $\frac{1}{2}mv^2 = KE$ , so  $v = \sqrt{\frac{2KE}{m}}$

$$= \sqrt{\frac{2 \times 1.6 \times 10^{-17} \text{ J}}{10^{-30} \text{ kg}}} = \sqrt{\frac{32 \times 10^{-17} \text{ J}}{10^{-30} \text{ kg}}} = \sqrt{32 \times 10^{13} \frac{\text{m}^2}{\text{sec}^2}}$$

$= 5.6 \times 10^6 \text{ m/sec}$

14.21

	Voltage	Current	Resistance
a)	2 volts	$I=V/R=4$ amps	0.5 ohms
b)	10 volts	2 amps	$R=V/I=5$ ohms
c)	$V=IR=15$ volts	3 amps	5 ohms

14.22

a) If thunder clouds are roughly 1000 meters high, then a field strength of about  $10^4$  volts/meter under the cloud would imply an earth-cloud potential difference of roughly  $10^7$  volts.

b) A charge of 50 coulombs transferred across a potential difference of  $10^7$  volts (that is,  $10^7$  joules per coulomb), would release roughly  $5 \times 10^8$  joules of energy as heat, light and sound.

14.23

The rate at which the kinetic energy of the charges in the beam is being increased is  
 $4 \times 10^6 \text{ volts} \times 4 \times 10^4 \text{ amps} = 1.6 \times 10^{11} \text{ watts!}$   
 The pulse lasts for only  $3 \times 10^{-8}$  seconds, so the energy of a pulse is  $1.6 \times 10^{11} \text{ watts} \times 3 \times 10^{-8} \text{ seconds} = 4.8 \times 10^3 \text{ joules}$ . It isn't clear from the advertisement what accuracy is intended for the figures, nor is it clear whether they are average or peak values. So, the expression "5000 joules" is not unreasonable, but certainly it seems that the company hasn't sold itself short.

14.24

The accelerating potential in a TV tube is about  $2 \times 10^4$  volts. A beam of  $10^{-3}$  amps will therefore require, and deliver, electric energy at a rate of

$$P = VI$$

$$= 2 \times 10^4 \cdot 10^{-3}$$

$$= 20 \text{ watts.}$$

If we assume that  $10^{-3}$  amps of beam all impinge on the screen, and that all of the energy of impact goes into producing visible light, then the total light output from the screen should be about the same as that of a 20-watt fluorescent lamp (which is considerably greater than the output of a 20-watt incandescent lamp, which puts out mostly heat).

14.25

$P = VI$ , or  $P = I^2R$ . Using either of these relationships, the power in each part of question 14.13 is

a) 8 watts.

b) 20 watts.

c) 45 watts.

14.26

Since the current is in a horizontal wire, its circular magnetic field at the same horizontal level is vertical. Thus, the compass needle would tend to turn in a vertical plane, which its suspension was not designed to allow. (The compass would have responded if it had been held over or under the wire, providing that the current in this situation does not happen to be in an east-west direction: why?)

14.27

to the north

14.28

3 amps to the north

14.29

a)  $qvB = \frac{mv^2}{R}$ ;  $R = \frac{mv}{qB}$ ; so  $R \propto mv$

b) Since  $q/m = v/RB$ , you would need to know the speed  $v$ , the magnetic field strength  $B$ , and the radius  $R$  of the particle's orbit.

14.30

The period  $T$  is given by the circumference divided by the speed:

$$T = \frac{2\pi R}{v} = \frac{2\pi(mv/qB)}{v} = \frac{2\pi m}{qB}$$

14.31

a) The magnetic force  $Bev$  is a centripetal force, so we can write

$$Bev = \frac{mv^2}{r}$$

Solving this equation for  $r$ , we get

$$r = \frac{mv}{qB}$$

Obviously,  $r$  decreases as  $B$  increases.

b) The force on the particle is perpendicular to both its velocity and the field. If the field lines converge, there will be a component of force in a direction away from the region of convergence. For certain combinations of  $v$ ,  $m$ ,  $q$  and  $B$ , the particle will "reflect" and reverse direction along the field.

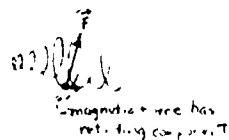

14.32

The magnetic field of the earth is directed from south to north. Using the right-hand rule, you will find that positively charged bodies will be deflected towards the east. They will appear to be coming "out of the west" and a directional detector would have an appreciably higher count rate if directed somewhat toward the west.

Study Guide  
Chapter 15

Solutions to Chapter 15 Study Guide

15.1

The main sources of energy were:

- a) "man-power"
- b) The energy of work animals such as oxen, horses, etc.
- c) The energy of work of moving water
- d) The chemical energy of coal, wood, oil, gas etc., that could be changed to heat energy by combustion and then to mechanical energy by steam, or internal combustion engines.

The energy was transported by such things as trains, wagons, trucks, etc; "man-power" often walked. Oil and gas flowed in pipes to where it could be used; the energy of moving water was transported in flumes, etc.

15.2

Yes. Newton's third law of motion implies a reaction. To detect this force, suspend a loop of current-carrying wire which is free to turn in the vicinity of the magnetic needle. (One type of sensitive current-indicating meter uses such a mechanism; it is called the D'Arsonval galvanometer.)

15.3

In all cases except (d).

15.4

Steady currents produce magnetic fields, but it requires changing magnetic fields to produce currents.

15.5

a) If you use the right-hand rule, you will predict that positive charges tend to move along b toward you. If you use the left-hand rule, you will predict that negative charges (free electrons) flow along segment b away from you.

b) The additional force is directed upward; opposite to the direction of motion of b.

c) The additional force is directed downward, opposite to the direction of motion of a. Again there is a reaction against what caused the motion of the wire in the first place. (There is a general principle, "Lenz's Law,"

which states that induced motion of a charge is always in such a direction as to cause a reaction against whatever initially produced the motion.)

15.6

There is no magnetic opposition to the turning of the coil unless a current is being generated, and of course, there must be a complete circuit before there can be a current in the coil of the generator. The lamp serves to complete the circuit.

When the current is being generated, the opposing magnetic force causes a torque (turning effect) which opposes the applied torque. So work is required to rotate the coil; mechanical energy is changed into electrical energy.

15.7

The magnet falling outside the loop of wire reaches the ground first. The magnet passing through the loop induces a current in the loop. The induced current has a magnetic field that opposes the motion of the magnet (see answer to question 15.5). So when the magnet is above the loop, the force on it is repulsive, reducing its acceleration. When the magnet is below the loop, the force is attractive, again reducing the acceleration.

15.8

Using of the hand rule twice shows that the additional force is opposite to the original direction of the charges. Thus, the current decreases. This decrease is due to the "back voltage" developed by the induced motion of the wire across the field.

15.9

The more slowly the motor goes, the greater is the current. As the motor speeds up, the "back voltage" across the coils increases, reducing the current in the coils.

15.10

a) Each of the dozen lamps dissipates 10 watts, so the entire set dissipates 120 watts. The electric power input is

$$P = IV$$
$$120 \text{ watts} = I \times 120 \text{ volts}$$
$$\text{so, } I = 1 \text{ amp}$$

b) We know the power dissipation in each loop is  $I^2 R$ , and the current in each bulb is 1 amp, so  $R$  must be 10 ohms.

c) If a 10-ohm lamp were connected directly across the 120-volt line, the current would be

$$I = \frac{V}{R} = \frac{120 \text{ volts}}{10 \text{ ohms}} = 12 \text{ amp.}$$

The electric power going to the bulb would be

$$I^2 R = 1440 \text{ watts!}$$

The lamps would burn out very quickly, probably before the fuse in the wall circuit burned out. (Note that the total current for a very short time would be 144 amps.)

15.11

a) The electric power input is  $P = IV$ , so, 10 watts =  $I \times 120$  volts. Thus  $I = 1/12$  amp.

b) The power dissipated by each lamp is  $I^2 R$ , so 10 watts =  $\left(\frac{1}{12}\right)^2 R$ , the  $R = 1440$  ohms.

15.12

a) The current required by the lamp is given by  $I^2 R_l = P_l$ , so for the 6-volt system,  $I^2 = \frac{6 \text{ watts}}{6 \text{ ohms}}$  so  $I = 1$  amp, and for the 12-volt system  $I^2 = \frac{6 \text{ watts}}{24 \text{ ohms}}$ , =  $\frac{1}{4}$  amp<sup>2</sup>, thus  $I = \frac{1}{2}$  amp.

b) The power loss in the connecting wires is given by  $I^2 R_w = P_w$ , so for the 6-volt system,  $P_w = (1 \text{ amp})^2 \times 1/5 \text{ ohm}$ , or 1/5 watt, and for the 12-volt system,  $P_w = (\frac{1}{2} \text{ amp})^2 \times 1/5 \text{ ohm}$ , or 1/20 watt. Yes, he reasoned correctly!

c) For the 6-volt system, the total resistance would be 6.2 ohms. Thus, the current would be  $\frac{6.0 \text{ volts}}{6.2 \text{ ohms}} = 0.97$  amp (rounded off to two significant figures). The power loss would then be  $(0.97 \text{ amp})^2 \times 1/5 \text{ ohm}$ , or 0.19 watt (to 2 sig. fig.). The power used by the lamp would be  $(0.97 \text{ amp})^2 \times 6 \text{ ohms} = \underline{5.6}$  watts.

For the 12-volt system, the total resistance would be 24.20 ohms. Thus, the current would be  $\frac{12 \text{ volts}}{24.2 \text{ ohms}} = 0.50$  amp (to 2 sig. fig.). Therefore, the power loss will then be nearly 0.05 watt, and the power used by the lamp would be nearly 6 watts. The man's reasoning was correct; and in addition to the larger power loss using the 6-volt system, the power output of the lamp in the 6-volt system is less than desired.

15.13

The output power is assumed equal to the input power. So,

$$I_s V_s = I_p V_p,$$

$$\text{and } I_s \cdot 6 \text{ volts} = 5 \text{ amp} \cdot 120 \text{ volts.}$$

$$\text{Thus, } I_s = 5 \text{ amps.}$$

15.14

The voltage ratio is the same as the turn ratio, that is,

$$\frac{V_p}{V_s} = \frac{N_p}{N_s}$$

where  $N_p$  and  $N_s$  represent the numbers of turns on the primary and secondary coils respectively. Assuming 100 per cent efficiency, the output power is equal to the input power,

$$I_s V_s = I_p V_p,$$

$$\text{so, } \frac{I_s}{I_p} = \frac{V_p}{V_s}.$$

Thus, equating both expressions for  $\frac{V_p}{V_s}$ ,

$$\frac{I_s}{I_p} = \frac{N_p}{N_s}.$$

15.15

The low-voltage coil needs the thicker wire, because the current is greater in the low-voltage coil than the high-voltage coil.

15.16

To produce a current in you, there must be a potential difference across you. Contact between a "live" power line and the car would create a large voltage between the car (and its contents) and the ground, but this would not in itself be dangerous. Leaping from the car could be safe; but if you were to touch the ground at the same time as you were touching the car...

15.17

Some of the factors were: the unexpected daytime uses for electric power; in motors, street railways, elevators, sewing machines, etc., and the fact that new industries needing constant power were attracted to a site at the falls.

**Study Guide**  
**Chapter 15**

15.18

Student report.

---

15.19

Answers might include doing work for people, providing a more healthful, comfortable environment and providing for rapid transportation and communication.

---

15.20

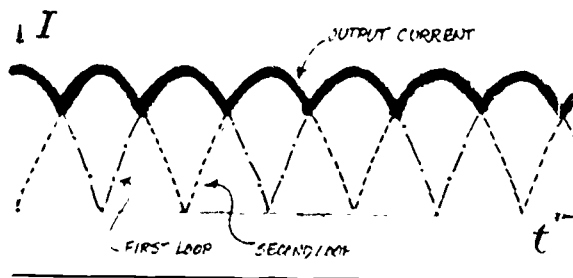

Solutions to Chapter 16 Study Guide

16.1

Oersted was inspired by a conviction, not supported by the existing evidence, that all physical phenomena are different forms of the same basic force.

16.2

No, a displacement current is only caused by a changing electric field. A steady electric field will hold + and - charges at a constant displacement but a displacement current requires a shifting (a changing displacement) of charge.

16.3

An electromagnetic wave is initiated by an accelerating charge. It propagates itself by the mutual induction of electric and magnetic fields.

16.4

- (a) the height of the water surface
- (b) the pressure or density of the air
- (c) the electric field strength and the magnetic field strength.

16.5

Each of these experiments was subject to some uncertainty of measurement. Reporting the speeds to five and six significant figures misrepresented the accuracy. The speeds might better have been reported as  $3.10 \times 10^8$  meters/sec and  $3.15 \times 10^8$  meters/sec, indicating that the third figure was in doubt. Maxwell repeated the capacitor experiment obtaining a value of  $2.88 \times 10^8$  m/sec. (The presently accepted value is  $2.997925 \times 10^8$  m/sec.)

16.6

Hertz could show they were polarized by rotating the detector ring—the sparks would be strongest when the two ends of the ring were in the same plane as the gap in the secondary winding of the induction coil.



16.7

Hertz showed that the waves had about the same speed as light and that they could be similarly reflected, diffracted, refracted and focussed.

16.8

- (a) Other theories accounted for the same observations.
- (b) The concept of the displacement current seemed mysterious to many scientists.
- (c) Most scientists were unaccustomed to the field concept.
- (d) Prior to Hertz's work, no new property of electromagnetism had been discovered using a prediction from Maxwell's theory.

16.9

- (a) Energy must be supplied to a source of electromagnetic radiation.
- (b) When the waves are absorbed, the absorber is heated.

16.10

Solve the equation  $f\lambda = c$  for the wavelength  $\lambda$ ;

$$\lambda = \frac{c}{f} = \frac{3 \times 10^8 \text{ m/sec}}{60 \text{ cycles/sec}}$$

$$= 5 \times 10^6 \text{ m/cycle}$$

$$= 5000 \text{ km/cycle (approx. } 1/8 \text{ the earth's circumference)!}$$

16.11

Wavelengths of "short" radio waves range from roughly 10 m to 100 m. They are short relative to the commercial AM broadcast band.

16.12

Radio waves from sparks etc. would superpose with the broadcast waves to produce changes in amplitude at the receiver antenna. FM receivers are designed to respond only to variations in the frequency of the radio wave, and not to variations in its amplitude.

Study Guide  
Chapter 16

16.13

Newspapers and magazines print on their own paper. Radio and TV stations are broadcasting in a medium common to all, where regulation and cooperation are required to prevent overlapping and interference.

16.14

The radiation which could escape from the surface into space would be FM and TV broadcasts, and visible light. AM radio wouldn't get through. Orbital satellites and radiation from nuclear explosions would be additional sources of information.

16.15

There are two reasons for the greater reception distances of radio waves than of waves used for TV and FM broadcasting. First, radio waves are trapped between the ionosphere and the earth, whereas the waves used for TV and FM pass through the ionosphere into space. Second, the longer wavelength of radio waves causes them to diffract more readily around obstacles such as mountains.

16.16

Kepler's third law (p. 61 of Unit 2) states that  $T^2 = ka^3$ . We can find the constant  $k$  that applies for earth satellites by using the period  $T$  and radius  $a$  of orbit of the moon, the only natural satellite of the earth.

From page 97 of Unit 2,  $T$  of moon = 27.3 days and  $a = 240,000$  miles. For this problem the arithmetic is made easier if we call this distance 1 unit. Then

$$k = \frac{T^2}{a^3} = \frac{(27.3 \text{ days})^2}{(1 \text{ unit})^3} = 743 \text{ days}^2/\text{unit}^3$$

Thus, for a satellite of period 1 day,

$$a^3 = \frac{T^2}{k}; \quad a = \sqrt[3]{\frac{T^2}{k}}$$

$$a = \sqrt[3]{\frac{(1 \text{ day})^2}{743 \text{ day}^2/\text{unit}^3}} = \sqrt[3]{1.35 \times 10^{-3} \text{ unit}^3}$$

$$\begin{aligned} a &= 1.16 \times 10^{-1} \text{ unit} = 0.116 \text{ unit} \\ \text{or } a &= 0.116 (240,000 \text{ miles}) = 27,900 \text{ miles} \end{aligned}$$

An alternative solution would be to use Eq. (8.8) from page 98 of Unit 2.

16.17

TV waves are reflected well by a large conducting object like an airplane, and the reflected wave interferes with the direct wave at the TV antenna. As the distance of the plane changes, the phase difference of reflected and direct wave changes, so that the superposed wave amplitude at the antenna goes through maxima and minima.

16.18

The TV picture information is carried by amplitude variations (AM) and the TV sound information is carried by frequency variations (FM). The TV sound is therefore much less affected than the picture is by static and passing aircraft.

16.19

The time required for the radar signal to travel from the earth to the moon and back to the earth will be the ratio of the total distance traveled divided by the speed of the signal. The distance to the moon (actually the radius of the orbit, but we will neglect the relatively small difference between the radius and the distances between the surfaces of the earth and moon) is given on p. 97 of Unit 2 as 240,000 miles, and on p. 122 of Unit 2 as  $3.84 \times 10^5$  km.

$$\text{Thus, the time} = \frac{2 \times 3.84 \times 10^5 \text{ km}}{3 \times 10^8 \text{ km/sec}}$$

$$= 2.56 \text{ sec or } 2.6 \text{ sec to two-figure accuracy.}$$

16.20

The trees and clouds appear bright in the photo because they absorb invisible light and re-radiate energy of a longer wavelength, infrared. The sky appears black because infrared (due to its relatively long wavelength) is scattered very little by the earth's atmosphere, also because the air is cool it emits very little infrared radiation.

16.21

An argument can be made that natural selection favored organisms whose eyes were sensitive to the light that was most plentiful. Which wavelengths are most plentiful depends on the sun's output and the transparency of the earth's atmosphere. (For the earth both of these factors



peak at roughly the same wavelengths; it isn't clear whether such a nice match is necessary for the development of seeing beings.)

Religious explanations are of course possible, but they are not open to scientific discussion.

---

16.22

The thermometer will receive ultra-violet radiation beyond one end of the visible spectrum, and infra-red radiation beyond the opposite end.

---

16.23

An interesting discussion topic.

---

16.24

Maxwell thought that scientific ideas are most completely absorbed when studied in the form in which they first appeared. This view may often be correct, but you will likely be able to think of many exceptions.

---

16.25

A principal reason for loss of support of the ether concept was that it wasn't used in the mathematical description of electromagnetism.

---

16.26

Discussion; other examples; inertial motion, circular orbits, the mobility of the earth, the remoteness of the stars, etc.

---

16.27

Discussion.

---

16.28

The body of the cat is analogous to mechanical models of the ether, the grin represents the mathematical description of the electromagnetic field.

---

Background and Development  
Current Balance  
Chapter 13

Summary of Demonstrations and Experiments  
Using the Current Balance

In this series of two demonstrations and two experiments students investigate the forces that can occur between two currents or between a current and a magnet. In both experiments (E35, E36) students work in three different groups, each group examining a different aspect of the current-current or current-field interaction. Each experiment is preceded by a demonstration.

The equipment note (see page 73) gives a full description of the design and operation of the instrument. Refer to it for any details not given in the notes on individual experiments and demonstrations.

The sequence of demonstrations and experiments is:

1. Demonstration 49: Currents and Forces  
Demonstration of forces between currents as a function of spatial orientation.
2. Experiment 35: Currents and Forces
  - a) Brief qualitative investigation of the interaction between a current and a magnet.
  - b) For the simple case of two parallel current-carrying wires, three groups of students work independently to find

$$F \propto I, F \propto l, F \propto 1/d.$$

These results are combined to give

$$F = k \frac{I_1 I_2 l}{d}.$$

The value of the constant  $k$  can be determined if time allows.

3. Demonstration 50: Currents, Magnets Forces

Demonstrates in more detail that there is a force between currents and magnets and establishes the directions of current, magnetic field, and force.

4. Experiment 36: Currents, Magnets, Forces

Two groups of students find that

$$F \propto I \quad F \propto l$$

which are combined to give

$$F = BI l.$$

A third group measures a particular  $B$ —the vertical component of the earth's magnetic field.

Sec. 13.1 Introduction

The text suggests two alternative ways of describing light: the scientific, quantitative method, and the artistic, emotional approach. Clearly a physics textbook must concentrate on the former, but there is nothing wrong with taking advantage of the natural fascination of the latter to arouse interest in the subject. Don't lose the opportunity to present demonstrations and discussions of color effects with lighting, painting and photography. Check the latest issues of Scientific American and photography magazines for news of recent theories of color perception, etc.

Optics is a large subject, and only a small part of it is covered in this course. Roughly speaking, we have omitted almost all of geometrical optics, on the grounds that both particle and wave models for light give equivalent predictions so these phenomena cannot be used to distinguish between them. Instead, we concentrate on physical optics—interference, diffraction, polarization—and look for phenomena that can be used to test theories of light. If you want to spend extra time on lenses and mirrors, be sure that there is some payoff from the viewpoint of added student interest and motivation, since geometrical optics is not needed for anything else in this course.

Sec. 13.2 Propagation of light

If there is a camera obscura locally available, be sure students have a chance to see it.

In most textbooks you will find the statement that Römer was the first person to determine the speed of light. You will find various values attributed to him, and most of these values are different even when converted to the same system of units (the average is about 2/3 the present value). Anyone who actually takes the trouble to read Römer's original paper will find that all he did was to estimate the time it takes light to cross a certain fraction of the earth's orbit. He also says that light would take less than a second to cross the diameter of the earth; since he thought the earth's diameter was about 9000 miles (depending on how you interpret the units he used) this means that the speed of light is greater than 9000 miles per second. But for seventeenth-century scientists the real significance of Römer's work was not the actual value of the speed of light, but the fact that it is finite rather than infinite. This is analogous to the case of Boyle's work on air pressure: Boyle is known as the discoverer of "Boyle's

law,  $PV = \text{constant}$ , but in fact he wasn't the first to find this relation by experiment. Instead, he did something even more important: he showed that air pressure is finite, and is responsible (rather than nature's horror of a vacuum) for holding up the mercury in a barometer, or the water in a suction pump. These two examples, Römer and Boyle, show how different (and how much more interesting) the history of science can become if we try to look at a scientist's work directly and in the context of its own times, rather than judging it, through the reports of textbooks, on the basis of how it solved problems that we now consider significant.

Although Römer did not apparently have data on the diameter of the planetary orbits from which he could compute the actual speed of light, such data was just becoming available at the time he worked. In 1672, the French astronomers Jean Richer and Jean Dominique Cassini determined the earth-Mars distance by triangulation of Mars. They used a baseline with Paris at one end and Cayenne, on the northern coast of South America, at the other. Since, as we saw in Unit 2, the relative distances of all the planets from the sun, and relative earth-Mars distance at a given time, could be found from the heliocentric theory, all these distances could be found as soon as one of them was known. The Richer-Cassini observations led to an earth-Sun distance of 87 million miles. Huygens, in 1678, used this value together with Römer's data on the time-interval to compute the speed of light. Huygens' value,  $2 \times 10^8$  m/sec, was published in his treatise on light in 1690, together with an analysis of Römer's observations; later scientists seem to have misread this passage and thought that Römer himself had gotten that value.

Another way of determining the velocity of light from astronomical observations was discovered by the British astronomer James Bradley in 1728. He found that certain stars change their positions in the sky during the year in a peculiar way. Although he was originally trying to observe the parallax of such stars, it turned out that this effect could not be attributed to parallax but was due, instead, to the component of motion of the earth at right angles to the line of sight from the star to earth. During the finite time that it takes for light from the star to go from one end of the telescope to the other, the telescope itself moves because of the motion of the earth, and so the telescope must be tilted slightly to see the star. This effect is known as stellar aberration, and its magnitude depends on the ratio of the orbital speed of the earth to the speed of light,

as well as on the position of the star relative to the plane of the ecliptic. Since the orbital speed is known, the speed of light can be calculated. The value obtained was within a few per cent of the present value.

Bradley's discovery of stellar aberration was historically important for another reason: it was, in a sense, the first direct astronomical evidence for the heliocentric theory! Yet by the time it was found, most scientists had already accepted the heliocentric theory for other reasons (see Unit 2). Here is an interesting example of the relative unimportance of experiments and observations, as compared to convincing theories, in changing a world view.

The subsequent history of determinations of the speed of light is reported in such books as J.M. Sanders, The Velocity of Light, Pergamon Press.

In Chapter 16, we note that Hertz's experimental determination that electromagnetic waves have the same speed as light was one piece of evidence for the hypothesis that light waves are a form of electromagnetic waves. In Chapter 20 we again encounter the speed of light as a maximum speed in relativity theory.

### Sec. 13.3 Reflection and refraction

In this section we look for properties of light that can be used to distinguish between wave and particle models. Note that we have in mind only one particular particle model, the rather special one proposed by Newton, which is based on assumptions about repulsive and attractive forces exerted by the medium on the particle.

At this point, the discussion of angles of reflection of waves from Chapter 12 should be reviewed. Note that we do not need Snell's law or the concept of index of refraction in our treatment on a qualitative level. However, if you do plan to treat electromagnetic waves more quantitatively, using Maxwell's equations, you could introduce the index of refraction here. You can then derive Maxwell's relation between index of refraction and electric and magnetic properties of the medium,  $n = \sqrt{\epsilon\mu}$ . This is a neat connection between optics and electromagnetism, and its experimental verification (by the "theoretical" physicist Ludwig Boltzmann) was one of the first triumphs of Maxwell's theory.

The point to make here, however, is not something about the index of refraction but rather the fact that both wave and particle models give the same relation, angle of incidence = angle of refraction. For the particle model this can be (and should be) derived directly

## Background and Development

### Chapter 13

from conservation of momentum, assuming that the "repulsive power" of the medium which the particle enters acts in a direction normal to the boundary. The component of momentum parallel to the boundary must therefore be conserved, and the component normal to the boundary is reversed, just as in an elastic collision of a gas molecule with the wall of its container. (In fact, in kinetic theory this is called "specular reflection" of the molecule.)

Be sure to point out why the light particle would be expected to speed up if it does enter the medium: the "attractive power" now takes over and accelerates it. This is where the peculiarity of Newton's model comes in; don't leave the impression that all particle models would make this prediction. We don't want to convince students so firmly of the validity of the wave theory that they will feel duped when they get to Unit 5!

#### Sec. 13.4 Interference and diffraction

The theory of the double-slit interference experiment, presented in Sec. 12.6, should be carefully reviewed at this point, so that Young's method for calculating the wavelength of light can be understood. Point out that because of the very small wavelength of visible light compared to that of sound, interference and diffraction can be observed only in special circumstances. This is why light ordinarily goes in straight lines and casts sharp shadows, whereas sound goes around corners.

The attack on Young by Henry Brougham (see margin of page 14) has some historical significance. Brougham was a politician, essayist and amateur scientist who had earlier published papers on light which Young had criticized. The Edinburgh Review, founded at the beginning of the nineteenth century, published articles on literature, religion, politics and science for a non-specialist but intellectual audience (perhaps the equivalent of today's New York Review of Books). Its authors, writing anonymously, often expressed their opinions intemperately. Brougham was a frequent contributor on scientific subjects; his review of Young's papers, quoted here, seems to have persuaded most British scientists to ignore the wave theory of light for about 20 years. This was partly because of the still-strong respect for anything Newton had said (or was thought to have said); partly because British science in the early nineteenth century was mostly empirical and anti-theoretical in nature. (Another example of this is the Royal Society's rejection of Herapath's kinetic theory in 1821: see Unit 3, p. 82.) Whittaker [History of the theories of Aether & Electricity, Vol. I, p. 102] has the following note on Brougham's character:

'Strange fellow,' wrote Macaulay, when half a century afterwards he found himself sitting besides Brougham in the House of Lords, 'his powers gone: his spite immortal.'

Further details of the Fresnel-Poisson story are contained in an interesting article by Epstein (see bibliography). The statement in the text that "Poisson announced gleefully to Fresnel that he had refuted the wave theory" is not supported directly by historical evidence, but it is a plausible reconstruction based on Poisson's known opposition to the wave theory and his persistent attempts to disprove it by any method possible.

#### Colors of thin films

In discussing Young you may wish to bring in his explanation of the colors of thin films. The following is quoted from Holton & Roller, Foundations of Modern Physical Science, p. 555:

Young showed that interference of light waves can account for the color patterns observed by Newton when white light incident on a thin film is reflected to the eye. Examples familiar to everyone are the colors of soap bubbles and of films of oil on a water surface, which are explained as follows. The thin film reflects some light from the front surface and some light from the back surface, and these two beams arrive together at the retina. Now suppose that the difference of distance traveled from the two surfaces to the eye is effectively half a wavelength of red light, or, using modern values, about  $\frac{1}{2} \times (7 \times 10^{-5})$  cm; then the red component of light will not be seen because the "crests" of the wave coming from one surface are canceled by the "troughs" of the wave coming from the other, and vice versa.

On the other hand, the difference of  $\frac{1}{2} \times (7 \times 10^{-5})$  cm corresponds to a full wavelength of blue light, and therefore the blue component of the reflected white light from the same region where red light has destructive interference will appear to be fully reinforced. For different film thicknesses, different components of light have destructive and constructive interferences, and so different hues can be observed to predominate over the whole surface.

#### Sec. 13.5 Color

As was mentioned above, the subject of color can be used to link physics with other interests of students. Within the structure of this course, the main purpose of talking about color is to introduce the concept of light waves of different wavelengths.

The influence of Newton's theory of color on eighteenth-century poetry is discussed, with many more examples, in Nicolson's book, Newton Demands the Muse.

Goethe's attack on Newton's theory of light is another aspect of the anti-mechanistic Romantic movement which we have already mentioned in Sec. 10.9. Further discussion of Goethe's theory, and its relation to physics, may be found in the article by Heisenberg and the book by Magnús listed in the bibliography.

#### Sec. 13.6 Why is the sky blue?

A new unit of length—the Angstrom,  $10^{-10}$  meters—is introduced in this section. As you know, it is a unit appropriate to atomic dimensions.

The purpose of this section is to illustrate how physics can answer a question people ask about the world. All one really needs to explain the wavelength-dependence of scattering is a general principle which we mentioned previously in connection with the difference between propagation of light and of sound; the wave doesn't interact much with solid objects unless they are roughly the same size as its wavelength.

#### Sec. 13.7 Polarization

The purpose of this section is to introduce the idea that light can be polarized, a fact which is explicable if light waves are transverse rather than longitudinal—hence (as pointed out in the next section) the need for the ether to be solid. Otherwise, polarization as such has little relevance to the unit; the paragraphs on Polaroid serve only to make a connection with the students' common experience.

Review Sec. 12.2 and try to make it plausible that only solids can transmit transverse waves. But be careful that students realize that figures like Fig. 12.4 are misleading when applied to the transmission of polarized light. Instead of having "slots" which permit waves polarized along the slot to pass through, substances like Polaroid contain long molecules which absorb waves polarized in the direction along the molecule. In this case, only waves polarized at right angles to the orientation of the molecules will get through. Thus the usual "picket-fence" analogy for transmission of polarized waves is just  $90^\circ$  wrong!

#### Sec. 13.8 The ether

The nineteenth century belief in the elastic ether—apparently required as a medium which could propagate transverse waves—looks to us more like a suspension

of disbelief. But perhaps it's no less plausible than the theories we now accept. One explanation offered was that a substance could act like a fluid for slow deformations, but like a solid for rapid motions such as light. In fact, there are many substances which do act this way. The "silly putty" compound sold in toy stores is an example: it can flow, bounce, or shatter, depending on the magnitude of the applied stress.

Students should leave this chapter with the impression that the wave model explains the properties of light rather well, yet something may go wrong if one tries to think of the waves as motions of a real physical medium such as the water waves studied in Chapter 12. The question should be raised, but remain open: how can there be waves without having something to wave?

#### Sec. 14.1 Introduction

It is essential to recognize the peculiar nature of the treatment of electricity and magnetism in this course before attempting to teach this chapter. Though it is a long chapter, it covers many topics that occupy several chapters in traditional texts. In fact, E & M is one of the subjects that is under-emphasized by Project Physics. We have tried to cut the material down to the bare minimum that is needed in order to understand electromagnetic wave theory and some of the later experiments in atomic physics. (The same technical background also can be used in explaining motors, generators, etc. in Chapter 15.) Among the subjects not covered in this chapter are: the interactions of magnetic poles with each other; mathematical form of the electrostatic potential of a point charge; properties of various kinds of circuits. We suggest that you do not try adding these topics the first time through—see how long it takes to get through the core of the Project Physics course before expanding it.

#### Sec. 14.2 The curious properties of lodestone and amber: Gilbert's De Magnete

This section can be treated as a reading assignment, providing the historical background for the transition from magic to science in E & M. Some students may be interested in reading more of Gilbert's book—it's available in a Dover paperback and should be in your library.

#### Sec. 14.3 Electric charges and electric forces

We assume that students have already learned the basic facts of electrostatics in earlier grades, or else that you will demonstrate them in the laboratory. The



## Background and Development Chapter 14

section is not supposed to teach the subject to beginners, but only serve as a review and reference. The only thing that should be really new here (aside from the terminology for electric units) is the idea of a mathematical analogy between different physical phenomena, as illustrated by the fact that both electric and gravitational forces cancel out on an object inside a hollow sphere. This is an important way in which mathematics helps to unravel the complexities of nature; we come to it again in Chapter 16, with Maxwell's theory of electromagnetism (analogy between fluid flow and lines of force).

Note that electrostatic induction is treated here only because it will be needed to understand Maxwell's "displacement current" in Chapter 16.

### Sec. 14.4 Forces and fields

The field concept is deceptively simple at first sight, and conceptual difficulties frequently come later. The reason for introducing the idea at such an elementary level is that we want to proceed rapidly to the rather abstract notion of a moving pattern of electric and magnetic fields in space, without reference to any sources. It's hard to believe, even today, that "empty" space can contain forces and energies disconnected from any kind of "matter."

Watch out for the "self-interaction" problem, which some students may stumble on: if a field produced by a point charge is an independent entity existing in space, exerting force on any charge, does that mean it also exerts a force on the charge that produced it?

Another trap: what about Newton's third law? How can a charge react back on the field that exerted a force on it? Such paradoxes result from accenting too quickly and uncritically the field concept.

### Sec. 14.5 The smallest charge

We depart from historical sequence (the Millikan experiment will be covered more fully in Unit 5) in order to show how one can actually use an electric field in an important application. You should be prepared to explain how a uniform field can actually be produced (two parallel plates), but there is no need to spend much time on this point. The significant thing to mention here is that already with these elementary ideas about electric charges and forces we can start thinking about exploring the atomic world, although we will need more information from other areas of physics (and chemistry) to interpret the results.

### Sec. 14.6 Early research with electric charges

Treat mainly as a reading assignment, but point out the connection with the law of conservation of charge.

Franklin believed that the two types of charges were not really different. He concluded that a positively charged body had an excess of electrical fire and a negatively charged body had a deficit of it. This implies that electric charge is not created or destroyed. The modern conservation of charge principle contains some of Franklin's basic ideas.

### Sec. 14.7 Electric currents

Volta's discovery opened a new era in science and technology by making electric currents readily available. The impact on physics can be seen in the remaining sections of this chapter, and the impact on technology in Chapter 15. Note also the use of currents to discover new chemical elements (especially by Humphry Davy in England). As was mentioned in Chapter 10, the discovery of interconnections of various kinds of natural forces (starting with Volta) in the first part of the nineteenth century was one of the historical factors leading to the formulation of the general law of conservation of energy.

### Sec. 14.8 Electric potential difference

The concept of electric potential difference is part of the essential core of this course, and should be carefully discussed. It serves to make the connection between electric currents and the energy concept (Unit 3), and will be used later in discussing electric power transmission and acceleration of particles.

### Sec. 14.9 Electrical potential difference and current

The following may serve as a roughly correct explanation of Ohm's law: if opposite charges are produced on the ends of a piece of conducting material, an electric field is set up in the material and a potential difference appears across the piece. Loose charges in the material will drift in response to the field, in such a direction as to neutralize the unbalanced charge—that is, to cancel out the force field and the potential difference. Left alone, the material would reach a steady state of zero field and uniform potential throughout. But if a potential difference across the material is continually maintained, say by connecting a battery to the ends of the material, then the drift of loose charges will continue. The charges will accelerate in the field during the time between collisions with molecules of the material. If we assume that after each

such collision the charge is scattered in a random direction, then the average component of velocity which it will acquire in the direction of the field will be the product of its acceleration and the average time during which it is accelerated:

$$v_{\text{drift}} = at_{\text{av}} = \frac{F}{m} t_{\text{av}}$$

As long as the force acting on the charge—that is, the potential difference  $V$ —is small enough so that the drift velocity is small compared to the average thermal speed of the charge, we can assume that the average time between collisions is roughly independent of  $V$ . Then the current (rate of flow of charges past a given point) will be proportional to  $v_{\text{drift}}$  and hence proportional to  $F$ , or to  $V$ :

$$I \propto v_{\text{drift}} \propto V$$

which is Ohm's law.

#### Sec. 14.10 Electric potential difference and power

No background and development for this section.

#### Sec. 14.11 Currents act on magnets

Here is Oersted's own account of the history of his discovery, written in the third person as part of an article on "Thermoelectricity" for Brewster's Edinburgh Encyclopedia (1830) Vol. 18, p. 573-589 (in the American edition of 1832, this article is in volume 17 on pages 715-732):

Electromagnetism itself was discovered in the year 1820, by Professor Hans Christian Oersted, of the university of Copenhagen. Throughout his literary career, he adhered to the opinion, that the magnetical effects are produced by the same powers as the electrical. He was not so much led to this, by the reasons commonly alleged for this opinion, as by the philosophical principle, that all phenomena are produced by the same original power. In a treatise upon the chemical law of nature, published in Germany in 1812, under the title Ansichten der chemischen Naturgesetze, and translated into French, under the title of Recherches sur l'identite des forces electriques et chimiques, 1813, he endeavoured to establish a general chemical theory, in harmony with this principle. In this work, he proved that not only chemical affinities, but also heat and light are produced by the same two powers, which probably might be only two different

forms of one primordial power. He stated also, that the magnetical effects were produced by the same powers; but he was well aware, that nothing in the whole work was less satisfactory, than the reasons he alleged for this. His researches upon this subject were still fruitless, until the year 1820. In the winter of 1819-20, he delivered a course of lectures upon electricity, galvanism, and magnetism, before an audience that had been previously acquainted with the principles of natural philosophy. In composing the lecture, in which he was to treat of the analogy between magnetism and electricity, he conjectured, that if it were possible to produce any magnetical effect by electricity, this could not be in the direction of the current, since this had been so often tried in vain, but that it must be produced by a lateral action. This was strictly connected with his other ideas; for he did not consider the transmission of electricity through a conductor as an uniform stream, but as a succession of interruptions and re-establishments of equilibrium, in such a manner that the electrical powers in the current were not in quiet equilibrium, but in a state of continual conflict. As the luminous and heating effect of the electrical current goes out in all directions from a conductor, which transmits a great quantity of electricity; so he thought it possible that the magnetical effect could likewise radiate. The observations above recorded, of magnetical effects produced by lightning, in steel-needles not immediately struck, confirmed him in his opinion. He was nevertheless far from expecting a great magnetical effect of the galvanical pile; and still he supposed that a power, sufficient to make the conducting wire glowing, might be required. The plan of the first experiment was, to make the current of a little galvanic trough apparatus, commonly used in his lectures, pass through a very thin platina wire, which was placed over a compass covered with glass. The preparations for the experiments were made, but some accident having hindered him from trying it before the lecture, he intended to defer it to another opportunity; yet during the lecture, the probability of its success appeared stronger, so that he made the first experiment in the presence of the audience. The magnetical needle, though included in

Background and Development  
Chapter 14 Chapter 15

a box, was disturbed; but as the effect was very feeble, and must, before its law was discovered, seem very irregular, the experiment made no strong impression on the audience. It may appear strange, that the discoverer made no further experiments upon the subject during three months; he himself finds it difficult enough to conceive it: but the extreme feebleness and seeming confusion of the phenomena in the first experiment, the remembrance of the numerous errors committed upon this subject by earlier philosophers, and particularly by his friend Ritter, the claim such a matter has to be treated with earnest attention, may have determined him to delay his researches to a more convenient time. In the month of July 1820, he again resumed the experiment, making use of a much more considerable galvanical apparatus. The success was now evident, yet the effects were still feeble in the first repetitions of the experiment, because he employed only very thin wires, supposing that the magnetical effect would not take place, when heat and light were not produced by the galvanical current; but he soon found that conductors of a greater diameter give much more effect; and he then discovered, by continued experiments during a few days, the fundamental law of electro-magnetism, viz. that the magnetical effect of the electrical current has a circular motion round it.

Sec. 14.12 Currents act on currents

We have intentionally avoided stating just what the law of force between currents is—when it is attractive, when repulsive, and how it depends on distance—so that students can "discover" it for themselves in the lab. There is no loss of continuity thereby as far as the text is concerned, since we never need the details of this force law later on.

The numerical factor of  $2 \times 10^{-7}$  in the definition of the ampere may cause some puzzlement. Although it is possible to cook up a pseudo-rational justification for it, it is probably better to state flatly that it is arbitrary, having merely the purpose of giving a convenient-sized unit for currents. (But of course the derived unit for charge, the coulomb, is not at all convenient.)

Sec. 14.13 Magnetic fields and moving charges

This topic deserves careful detailed discussion. You should familiarize your-

self with the general expression for the "Lorentz force" with fields and velocities at arbitrary angles, but for the purposes of this course the special case of right angles should be sufficient. Also, look ahead to the applications of this force law in Chapters 15 (electromagnetic induction) and 16 (E and B vectors at right angles in electromagnetic waves). Chapters 18 (Thomson  $q/m$  experiment) and 22 (isotope separation).

Chapter 15—Background and development is provided for Sections 15.1 and 15.3 only.

Sec. 15.1 The problem: getting energy from one place to another

This chapter is intended as a change of pace: very little physics is introduced, but the applications of physics to technology and hence to social problems are stressed. Class time should be spent mainly on (1) explaining the principle of electromagnetic induction and the operation of simple generators and motors; (2) discussion of social impact of electric technology. The last section, on electricity and society, should stimulate some debate on the general subject of the value of technology. Students should be encouraged to amplify or criticize both the optimistic and pessimistic views presented in the text.

For additional background information we recommend the biography of Faraday by Williams, and the book Making of the Electrical Age by Sharlin (see bibliography for details and other books).

Sec. 15.3 Faraday's early work on electricity and lines of force

Physics textbooks often state or imply that Ampère discovered the correct law of force between current elements. Actually, the law which is now accepted and attributed to Ampère is somewhat different from the one Ampère himself proposed, although it is equivalent when one integrates over the entire current. The difference is significant in the historical perspective of this section: Ampère himself thought that the force must act along the line between the current elements. For a detailed discussion of this point, see R.A.R. Tricker, Early Electrodynamics, Pergamon Press; this book includes selections from Ampère's own papers. (A much shorter mathematical discussion may be found in Whittaker's History of the Theories of Aether & Electricity, vol. 1, p. 85-88; note especially Heaviside's remarks quoted on p. 88.)



### Sec. 16.1 Introduction

The main idea to emphasize in this introductory section is Faraday's suggestion that light might be a travelling disturbance in magnetic and electric lines of force. Maxwell's development and mathematical refinement of Faraday's idea is described in the next section.

### Sec. 16.2 Maxwell's formulation of the principles of electromagnetism

The idea of a displacement current in an insulator is introduced to make plausible Maxwell's contention that a changing electric field has a changing magnetic field associated with it, regardless of whether the changing electric field is in a conductor, insulator or even in free space. The concept of the displacement current serves as a crutch; little time should be spent on it.

The fact that Maxwell's mechanical model suggested effects that hadn't been yet observed is important. However, the details of how the model "worked" are of little significance. (In fact, much difficulty was encountered by the writers in attempting to visualize its operation—some of the arrows appear to be in the wrong direction.)

The two important principles encompassed by Maxwell's theory—the production of a magnetic field by a changing electric field, and the production of an electric field by a changing magnetic field—will likely be much clearer in the minds of your students if you spend 5-10 minutes of class time discussing the illustrative diagrams bordering pp. 110, 111.

### Sec. 16.3 The propagation of electromagnetic waves

The description given of how electromagnetic waves propagate through space—by the reciprocal induction of electric and magnetic fields—is handicapped by the limitations inherent in the English language. It is extremely difficult to phrase a description that successfully avoids leaving the impression that there is a time difference in each induction. For example, when we say that a changing electric field "produces" a magnetic field, we wrongly suggest that one precedes the other, when in fact they exist simultaneously. (Draw the attention of the students to the relevant marginal note on p. 112.)

The remarkable similarity between the speed of electromagnetic waves as calculated by Maxwell and the known value of the speed of light should be emphasized. The similarity could have been a coincidence, but Maxwell believed otherwise. His subsequent mathematical efforts resulted in an elegant and com-

prehensive theory of electromagnetism, but a theory which remained to be proven.

### Sec. 16.4 Hertz's experiments

The experiments of Hertz provide a classic example of the testing of the predictions made on the basis of a theory. Hertz showed that electromagnetic waves of many frequencies could exist, had properties similar to those of light and had the same speed as light.

To fully understand Hertz's experiments, students would need to know much more about resonance—unfortunately it has not been possible to allocate space to that discussion in the text—if you have the time and a suitable class it would be time well spent. See E38.

The Project Physics micro-wave equipment is an invaluable tool in developing student appreciation of the "light-like" behavior of electromagnetic waves.

### Sec. 16.5 The electromagnetic spectrum

It is worth emphasizing that whereas the electromagnetic spectrum covers a range of  $10^{25}$  in frequency (or wavelength), all electromagnetic radiation originates from accelerated electric charges. Be careful to avoid making the general statement that all frequencies of electromagnetic radiation have the same speed, unless you add—in space. The fact that the speed of radiation in a dispersive medium depends on frequency is of course the reason we can use prisms to obtain the spectrum of white light, why rainbows are formed, etc., etc. All media except a vacuum are dispersive to electromagnetic radiation. (Such is not the case for sound waves.)

### Sec. 16.6 Maxwell: intellectual characteristics and attitudes

A number of interesting discussion topics arise in this section. SG 16.24 focuses on one such topic—the value of studying original works of science. Is Maxwell correct in his belief that "science" can best be learned when in its original state? Is there value in his recommendation to study not only those procedures that succeeded, but also those that failed? Your students may by this time have seen sufficient original works quoted and discussed to have quite strong opinions on the first of these questions.

Some might argue that Maxwell is incorrect, that it is better to learn from the interpretation of the original work by someone who specializes in teaching and communication. Others might claim that the excitement of studying original papers more than compensates for any awkwardness of expression that might exist in the original work.

## Background and Development

### Chapter 16

The second question raised above is a fundamental one. Those who advocate study of only the successes of science might be asked how in that situation a person would gain any appreciation of the limitations of scientific inquiry, or of how scientific progress comes about. In many cases, the "failure" of an experiment leads to important breakthroughs in thinking. (e.g.,—The failure of Kepler in attempting to describe the motion of the planets in terms of circular orbits resulted in his discovery of the elliptical shape of the orbits.)

#### Sec. 16.7 What about the ether?

As indicated in Section 13.8 and in the text itself, the ether concept returned to nineteenth century physics as a metaphysical necessity for a mechanical interpretation of the wave theory of light and electromagnetism. It is well known that Einstein's 1905 work on special relativity disregarded the ether as superfluous and that his critique of simultaneity was based on the centrality of electrodynamic rather than mechanical interpretations of electromagnetic theory. However, many myths have grown around the origins of relativity theory, not least of which is its supposed dependence upon the Michelson-Morley ether-drift experiment of 1887. And so we end this unit with a question in the title that can be picked up again in Secs. 18.5 and 20.1 through 20.3.

The fact that the luminiferous ether as the electromagnetic ether died hard in the controversies over relativity theory early in this century can prove embarrassing to a teacher whose students might discover respectable physicists writing about the ether of space long after 1905. In spite of the null results of Michelson-Morley and other similar experiments (e.g., Rayleigh-Brace, Trouton-Noble), the generation of physicists who reached maturity before 1900 were generally extremely reluctant to give up all forms of belief in an ether. Einstein himself, after 1920, as well as Michelson, Lorentz, Poincaré, Sir Oliver Lodge, J. J. Thomson, D. C. Miller and others, seem to have harbored some hope that the vacuum of space might somehow someday be filled once again. But the new generation of mathematically proficient professional physicists constituted a majority in favor of fields and particles who likewise felt no need for the ether hypothesis.

In view of recent research on the influence of the Michelson ether-drift experiment on Einstein's special relativity, it is probably best to consider the latter as more of an intuitive leap than an experimentally-based conclusion—another example of theory at the vanguard with experimental tests continuing a "mob-up" operation. In the case of the Michelson experiment, only during the decade of the twenties was it definitively repeated, and by then the wave-particle duality and Bohr's complementarity principle, among other developments, had completely changed the presumptions of physics. Students should be encouraged to discover these disjunctions in scientific advance for themselves, and those who are especially curious about space-time should be introduced to the Project Physics supplementary chapter, Time and Space According to the Special Theory of Relativity. Other references to relativity theory may be found there and with Sec. 20.1.

**Transparencies**

- T30 **The Speed of Light**  
Visualizations of the Roemer and Michelson methods for determining the speed of light are presented.
- T31  **$\vec{E}$  Field Inside Conducting Sphere**  
A geometric and electrostatic argument shows in a step-by-step fashion that the electric field strength inside a hollow metallic charge-carrying sphere is zero.
- T32 **Magnetic Fields and Moving Charges**  
A multiple transparency illustrating forces on moving charged particles in magnetic and electric field, forces on current carriers, forces on moving conductors, and the principles of the ac and dc generators.
- T33 **Forces Between Current Carriers**  
Explanations for attractive and repulsive forces between parallel current carriers are given in terms of moving charged particles in magnetic fields.
- T34 **The Electromagnetic Spectrum**  
A double-transparency showing the electromagnet spectrum with a full-color insert of the visible spectrum, and a number of emission and absorption spectra of the elements.

**Film Loops**

**Standing Electromagnetic Waves**

A 435 megacycle/sec transmitter feeds an antenna at one end of a metallic trough. When a metallic reflector is positioned at the other end, a standing wave is formed. Many small lamp bulbs at the centers of tuned dipole make the pattern visible. Polarization is shown. Finally, the standing waves in this and the preceding two loops are displayed simultaneously to emphasize the existence of nodes as a fundamental property of any standing wave.

**Films (16 mm)**

- F30 **Speed of Light**  
William Siebert, MIT, MLA, 21 minutes, \$120.00.  
Outdoors at night Dr. Siebert measures the speed of light in air over a 300-meter course using a spark-gap, parabolic mirrors, a photocell and an oscilloscope. In the laboratory he compares the speed of light in air and in water using a high speed rotating mirror.

- F31 **Introduction to Optics**  
E.P. Little, PSSC, MLA, 23 minutes, \$180.00 (color).  
Deals with approximation that light travels in a straight line; shows the four ways in which light can be bent—diffraction, scattering, refraction and reflection; refraction illustrated by underwater photography to show how objects above water appear to a submerged skin diver.
- F32 **Coulomb's Law**  
Eric Rogers, Princeton, MLA, 30 minutes, \$150.00.  
Demonstrates the inverse-square variation of electric force with distance, and also the fact that electric force is directly proportional to charge. Introduces the demonstration with a thorough discussion of the inverse-square idea. Also tests inverse-square law by looking for electrical effects inside a charged hollow sphere.
- F33 **Electrons in a Uniform Magnetic Field**  
Dorothy Montgomery, Hollins College, MLA, 11 minutes, \$60.00.  
A spherical cathode-ray tube with a low gas atmosphere (Leybold) is used to measure the curvature of the path of electrons in a magnetic field and, with reference to the Millikan Experiment, the mass of the electron is determined. The math involved is worked out with the experiment.
- F34 **Electromagnetic Waves**  
George Wolga, MIT, MLA, 33 minutes, \$150.00.  
Shows why we believe in the unity of the electromagnetic radiation spectrum. Experiment shows that the radiation arises from accelerated charges and consists of transverse waves that can be polarized. Interference (Young's double-slit experiment) is shown in four different regions of electromagnetic spectrum; X ray, visible light, microwave and radiowave.

MLA—Modern Learning Aids. See Unit 2 Teacher Guide, page 73.

**Aid Summary  
Reader**

**Reader Articles**

1. LETTER FROM THOMAS JEFFERSON, JUNE 1799  
Thomas Jefferson  
1799  
A great American writes about the significant role of science in the education of the individual and in the creation of American society.
2. ON THE METHOD OF THEORETICAL PHYSICS  
Albert Einstein  
1934  
Einstein discusses the factors that lead to a scientific theory.
3. EXPERIMENTS AND CALCULATIONS RELATIVE TO PHYSICAL OPTICS  
Thomas Young  
1855  
When Thomas Young performed his famous interference experiments, Huygen's wave theory of light had been abandoned in favor of the corpuscular theory of light. But Young's experiments pointed strongly to the wave theory.
4. VELOCITY OF LIGHT  
A.A. Michelson  
1927  
The velocity of light is a significant constant in modern physics. A.A. Michelson, also known for the Michelson-Morley experiment, traces the studies, experiments, theories and conclusions relating to the velocity of light.
5. POPULAR APPLICATIONS OF POLARIZED LIGHT  
William A. Shurcliff and Stanley S. Ballard  
1964  
Bees navigate by polarized skylight and water fleas and horseshoe crabs by light polarized through water. Sunglasses, camera filters, and the not-yet successful glare-free auto headlights operate by absorbing polarized light.
6. ACTION AT A DISTANCE  
James Clerk Maxwell  
Maxwell explains the apparently baffling behavior of one body acting on another without any apparent connection.
7. THE ELECTRONIC REVOLUTION  
Arthur C. Clarke  
1962  
Clarke writes here a brief informal review of the electronic age, past and present.
8. THE INVENTION OF THE ELECTRIC LIGHT  
Matthew Josephson  
1959  
It is generally assumed that Thomas Edison's incandescent lamp was the product of inspired tinkering. But it was but one element in a more far-reaching invention: an entire system of electric lighting.
9. HIGH FIDELITY  
Edgar Villchur  
1966  
Hi-fi is a much misused term. This selection discusses both the human and electronic factors involved in accurate reproduction of sound.
10. THE FUTURE OF DIRECT CURRENT POWER TRANSMISSION  
N.L. Allen  
1967  
Allen compares the use of alternating and direct current for long-distance power transmission.
11. JAMES CLERK MAXWELL Part II  
James R. Newman  
1955  
Reader 3 contained the first part of Newman's biography of this outstanding mathematician and physicist. This final part is devoted primarily to electromagnetic theory.
12. COLLECTION OF MAXWELL'S LETTERS
13. ON THE INDUCTION OF ELECTRIC CURRENTS  
James Clerk Maxwell  
1881  
Oersted established a connection between electric currents and magnetism; Faraday found the connection between magnetic fields and induced electric currents. But it was Maxwell who synthesized and extended the two results.
14. THE RELATIONSHIP OF ELECTRICITY AND MAGNETISM  
D.K.C. MacDonald  
1964  
The magnetic properties of certain materials and the electric effects produced, for example, from rubbing glass with cat fur, were known in ancient days. Oersted's experiment with electric current and a compass showed that electricity and magnetism were related. Maxwell combined the two phenomena in his electromagnetic equations.

15. THE ELECTROMAGNETIC FIELD  
Albert Einstein and Leopold Infeld  
1961  

The formulation of Maxwell's equations opened the new area of science called electromagnetism and its far-reaching consequences.
16. RADIATION BELTS AROUND THE EARTH  
James Van Allen  
1959  

Instruments borne aloft by artificial satellites and lunar probes indicate that our planet is encircled by two zones of high energy particles, against which space travelers will have to be shielded.
17. A MIRROR FOR THE BRAIN  
W. Grey Walter  
1963  

The brain has long puzzled men. W. Grey Walter discusses here electrophysiology, the relation between electricity and nervous stimulation.
18. SCIENTIFIC IMAGINATION  
Richard P. Feynman, Robert B. Leighton,  
Matthew Sands  
1963  

Science demands a keen imagination. Physics is full of concepts that we cannot picture in our minds. Therefore the authors recommend taking a "mathematical view."



De. Jachow Museum, Munich



### D47 Some Electrostatic Demonstrations

There is a great wealth of good demonstrations in electrostatics. We have tried to make a selection on the basis of what is most important, what can be understood, what is likely to be remembered, what relates to other topics in the course. Since the equipment for giving demonstrations varies so greatly and most of it is well known, we have described a minimum number of specific techniques. We prefer to encourage the teacher's enthusiasm for his own favorite demonstrations rather than to prescribe a set of procedures.

#### The Basic Argument

When different materials are brought into close contact and then separated, each is likely to show a change in behavior—they may attract or repel other bits of matter. These changes in behavior are called "electrical effects," and a body showing these effects is said to have an "electrical charge." It is important to note that unaided human senses do not respond to the presence of charges. This means that we can detect the presence of charges on an object only by observing the effects which they produce on another object.

#### Demonstrations

There are many ways to produce charges and to show the kind of behavior that is called "electrical effect," such as attracting bits of paper. One specific technique will be useful in a later demonstration, so it should be tried here.

Stick a strip (6 to 12 inches) of plastic tape (such as plastic electric tape or Scotch brand "magic transparent") to a strip of vinyl; call this unit A. Prepare a second similar unit; call it B. If the process of preparing the units charges them, they must be discharged before starting the demonstrations. This may be done by running cold water over them, and drying them either by waving in air or patting with a towel. The two units neither attract nor repel each other.

When unit A is pulled apart, new behavior is observed. The tape attracts unit B; the vinyl also attracts B; and the tape attracts the vinyl.

Now pull unit B apart, and additional behavior patterns can be observed. The two tapes repel each other, and so do the two vinyls.

The above, or similar, demonstrations show that there are three patterns of behavior which the students observe: attraction, repulsion, and no force at all. The results can be summarized in

a table, but be careful at this stage not to let your prejudice as a teacher who "knows the answers" misinterpret the evidence obtained so far. There are three behavior patterns, suggesting three states of charge.

	Type X	Type Y	Type Z
Type X	no forces	attraction	attraction
Type Y	attraction	repulsion	attraction
Type Z	attraction	attraction	repulsion

This is not the time to explain that "Type X" is uncharged. After all, Type X does show the electric behavior of attracting Y and Z.

Some properties of electric charge can be shown most easily with an electroscope. The explanation of the electroscope is not simple, and is not really relevant. If the description is given at all, use terms that are consistent with but do not actually imply, a fluid theory of electricity. Quantization of charge is a later and not at all obvious discovery—although most students will have a vague familiarity with "electrons." It is only required at this point that the student realize that an electroscope works because, when charged, the mutual repulsion or attraction of its parts causes a light vane to swing out.

An electroscope that is encased on two sides by glass can be made more visible to a class by projection. Almost any small filament light source placed a short distance from the electroscope will project a shadow onto the blackboard adequately, even in a fully lit room.

#### CONSERVATION OF CHARGE

If a pie tin or coffee can is placed on top of the electroscope, any charged body lowered into the tin will cause the electroscope vane to deflect. With this "Faraday ice pail" apparatus we can demonstrate a most important aspect of electric charges: the two forms of charge we called Y and Z tend to cancel each other. (A description of Faraday's "ice pail" experiment can be found in Holton and Roller, p. 443.)

Prepare a tape-vinyl unit and produce the two charges by separating the strips. Lower one at a time into the tin to show that they are, in fact, charged. Now drop the tape into the tin and leave it there. When you drop the vinyl in (get it all the way in, but do not touch the tin with your fingers), the vane will return toward its normal position. If you have moved rapidly enough so that charge leakage has been small, the charges should almost exactly neutralize each other.

## Demonstrations D47

Apparently the two kinds of charge tend to cancel each other's effects. Our demonstration suggests, but clearly does not prove, that when creating the two charges by pulling the strips apart, you created equal amounts, and that when you put them back into the can, one charge just cancelled the other.

The fact that the tape-vinyl unit was of Type X (it did not pick up bits of paper and did not attract another tape-vinyl unit) suggests that Type X in Table 1 is not really a third type of charge at all. It can be considered as having equal amounts of Type Y and Type Z—or, in normal language of physics, Type X is merely the condition of being uncharged.

It is at this point in the argument that it is reasonable to talk about two kinds of charge—why? We could continue to call Y and Z, but which are called (+) and (-) in physics. Point out that there is no evidence for the existence of any third kind of charge.

At this point, students thinking about Table 1 may recognize a problem. The first column in the table implies that Type X, the uncharged state, can attract (or be attracted by) the (+) and (-) charges, but cannot exhibit repulsion! Let the students ponder this one; do not give them an answer!

## INDUCTION

If a charge is brought near an electro-scope, the observed deflection cannot be accounted for by saying that the electro-scope has been given a charge. Let the students discuss this; guide them to the usefulness of representing various steps with the aid of strip-like cartoons, as found on page 484 of Holton and Roller. You may not have to tell them that this behavior can be explained in terms of a redistribution of the charges on the electro-scope. Let the students develop the thesis that although the electro-scope still has as much (+) charge as (-) charge, the forces described by Table 1 could result in a redistribution of charges. After the students have worked out a solution in their own words, you can introduce the language of induction.

It may be useful at this stage to introduce the technique of charging an object by induction. If a demonstration is given without any comment from the teacher, it can be a good homework problem for students to try to explain the technique. We do not want to become sidetracked into a lengthy demonstration or discussion of specialized techniques, but in the experiment on Coulomb's law it will be necessary to charge pithballs by induction.

## ELECTRIC CHARGES AND "ELECTRICITY"

It may be impossible to put students in the frame of mind that existed when no direct connection between static and current electricity was known. Today students are so used to the term "electricity" that they may find it impossible to believe that anyone ever really thought that the two phenomena called by the same name could be different.

Suggest to the students that there is a problem here, but that they already have a possible solution to it. We recognize charges by the effects they produce—repulsion and attraction. Students do not usually think of these same effects as indicators of the presence of electric currents.

When the students were asked to "explain" why an uncharged electro-scope deflects when brought near a charge (induction), they accepted the idea that charges could move as they redistributed themselves on the electro-scope. Ask the students whether a charge in motion exhibits behavior which we associate with current electricity.

An electro-scope can be charged (or discharged) through a neon bulb, such as the bulb used in a blinky, or NE-2. The glow is brief and dim but visible.

Transfer charge from a charged electro-scope to a metal plate on an insulating handle. Discharge the electro-scope completely by grounding it. Now transfer the charge from the plate back onto the electro-scope through the leads of the neon bulb. The bulb will flash. A sensitive meter, about 50  $\mu$ a, should give just a perceptible kick if used in place of the bulb.

There is the inverse question: can a current source be made to exhibit the behavior that we use to detect charges? This effect is difficult to show without having to introduce techniques that distract from the issue at hand. Simply connecting the terminals of a cell to the electro-scope will not produce any deflection. A high voltage supply—giving 500 volts or more—should give a small deflection. (Note that a charged comb, which produces deflection in an electro-scope, must be a high voltage source, although a very weak transient current source.)

For lower voltages it is necessary to add extra capacitance to the system. A metal plate is placed on the top of the electro-scope plate, the plates separated by a piece of paper. Attach terminals of a 45v (or more) cell to the two plates. Disconnect the lead to the electro-scope, and then pull the upper plate away. The electro-scope will show considerable deflection.



THE CHARGE THAT IS "LOOSE" IN SOLIDS

There are other ways than those mentioned for separating charge from neutral matter—using heat, light, chemical reaction, magnetism and radioactivity. The chemical-reaction effect has already been demonstrated by the battery. Almost invariably, the charge that can be separated is that kind which has been named "-", suggesting that in conducting solids the "+" charges are more or less fixed in place and the "-" charges are loose and can move around.

Ultraviolet light can knock electric charge out of some metals. Shine a light source with a strong ultraviolet component (carbon arc, mercury arc) on a freshly cleaned (with sandpaper or steel wool) zinc plate atop the electroscope. If the electroscope has been given a "+" charge, nothing will happen (because any "-" charge knocked out will be pulled back immediately). If the electroscope has been given a "-" charge, the leaves will quickly collapse.

If a metal wire is made quite hot, some electric charge is freed by the agitation. If the heating is done in a vacuum, the charge can drift across to an oppositely charged plate. The IK3 (IG3, IB3) vacuum tube is such a setup. Charge knocked out of the hot wire can drift to the cylinder if the cylinder has a charge opposite to that of the escaped charge. Connect the plate terminal on top of the tube to the electroscope and charge the electroscope "-". Connect the filament terminals to a 1.5v battery to heat the wire. Then repeat the experiment with the electroscope charged "+." (The "-" charge freed from the wire will be pulled to the plate and balance the "+" charge on the electroscope, causing it to collapse quickly.)

The appearance of charged particles emitted in radioactivity is discussed in a later lab.

ELECTRIC FIELD

Here are two methods that can be used to explore the shape of electric fields:

1. Place electrodes of various shapes into a dish of oil and charge them with a Wimshurst machine or Van de Graaff generator. Grass seeds, hair clippings, lycopodium, etc., sprinkled on the oil, will polarize and line up along the electric field direction. A transparent tray can be used on the overhead projector
2. Suspend a charged pithball from a stick on a thin insulating thread, and use it as a roughly quantitative indicator of fields around charge spheres, plates and wires.

Use a point light source to project the demonstration. The angle between the thread and the vertical gives a rough measure of the forces. Show the uniformity of the field near a large plate, and the 1/r drop-off of the field near a long charged wire.

To prevent leakage of charge from the pointed ends of a charged wire, fit the ends with small metal spheres. Even a smooth small blob of solder at the ends should help.

Plastic strips rubbed with cloth are adequate for charging well-insulated spheres, plates, or wires.

D48 The Electrophorus

The electrophorus consists of two parts: a slab of wax or other non-conductor, and a circular metal plate, (slightly smaller than the wax) with an insulating handle.

1. Charge the wax by rubbing it with fur.
2. Place the metal plate down on it.
3. Touch the top surface of the metal plate.
4. Lift the metal plate off the wax slab, by the insulating handle.
5. Show that the metal plate is charged by using it to charge an electroscope, or by discharging it through a neon bulb. On a dry day you may be able to draw a spark from it.
6. Discharge the metal plate completely.

Steps 2-6 can now be repeated over and over again without recharging the wax.

Where does all this charge come from? Why does the wax not lose its charge? Is this a violation of conservation of charge?

To explain the apparent paradox draw a series of diagrams showing the situation at each step:

1. The wax is charged by rubbing

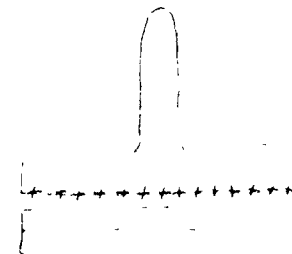

2. Negative charge of wax attracts positive charge to bottom of metal plate, repels negative charge to top. There is separation of charge in the plate, but it still has no net charge.

## Demonstrations

D48

D49

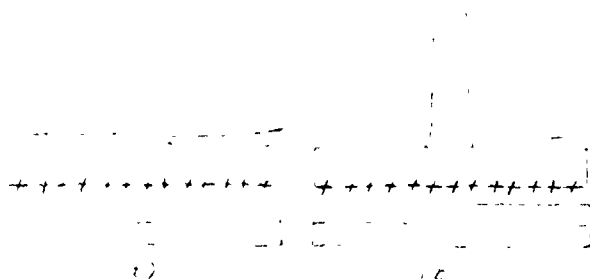

3. Some negative charge leaves plate via demonstrator's finger, hand, arm, etc. to earth. When finger is removed, plate has net + charge.

4.

This explains why the wax retains its original charge. But it does not explain how we were able to charge the electroscope, or light the neon bulb repeatedly, since the action requires an expenditure of energy every time. Is this a violation of the law of conservation of energy? Or, if not, where does this apparently unlimited energy come from? The answer is that work is done by the demonstrator every time he separates the metal plate (+ charge) from the wax (- charge), in step 4.

## D49 Currents and Forces

(Do before Experiment 35\*)

The purpose of this demonstration is twofold. It introduces the students to the apparatus used in the experiments; this will save them valuable time. It points out that the spatial configuration of the two currents—whether they are parallel, perpendicular or antiparallel—has an effect on the forces that result. Among other things, these relationships are an important part of the design of the current balance; an understanding of why only the top wire of the fixed loop is considered depends upon the discussions developed in this demonstration.

Forces exist between two parallel (or antiparallel) currents, but not between currents that are perpendicular.

### Equipment

- 1 current balance, with the longest loop
- 1 power supply, 6-8V dc
- 2 rheostats—5 ohms, 5 amps
- 2 ammeters, 0-5 amps dc wire leads
- ring stand with test-tube clamp
- hook-up wire with alligator clips
- paper clips

5.



6. No charge on metal plate, all original charge on wax remains.

Procedure

1. Turn the frame upside down and stand it vertically. This provides a horizontal wire (of 10 turns) near the top of the frame.

2. Support the balance beam, with the longest loop attached, so that it can swing freely with the loop just above the top of the fixed coil. One way to do this is to support the knife edges on paper clips which are in turn held by alligator clips.

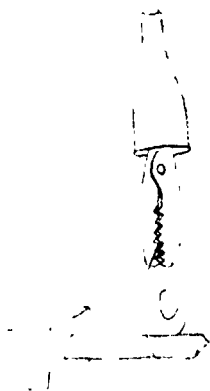

you have one of the older (1966-67) versions of the current balance you can hold the balance support bar in a test tube clamp.

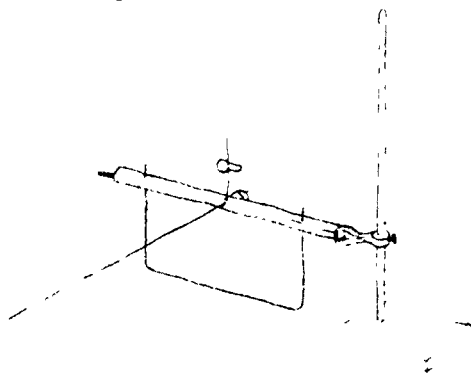

3. Set the balance for minimum sensitivity by sliding the sensitivity clip down as far as it will go. (In this way the interaction between the loop and the earth's field will not be observed.)

4. Connect the balance loop through the rheostat and ammeter to the power supply. Adjust the current to about 4 amps.

Connect the fixed coil in a similar way, and set the current in it to 4 amps or so. The values of the currents are not critical. Since students may not have had much experience connecting elec-

tric circuits, it is probably best to make these connections in front of the class, not ahead of time. This is the time to explain some of the terms such as resistance and rheostat that are used in the student notes. A running commentary or a dialogue between teacher and class on what is being done, and why, will be informative.

The Demonstration

By moving the ring stand or the frame into different relative positions, you can show students the following relationships:

1. If the wires are perpendicular, there is no observable force between them.



2. If the wires are parallel and in the same horizontal plane, there is an observable force the direction of which (attraction or repulsion) depends upon the relative directions of the currents (parallel or antiparallel).



The same current in the bundles of ten parallel wires has a much (ten times) bigger effect than the same current in the single blue wire.

3. If the wires are parallel, but the balance loop is directly above the fixed loop, there is no observable thrust:

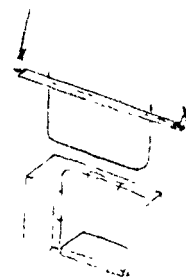

Be sure to discuss this until students

## Demonstrations

D49

D50

realize that there may be a force, but that this balance does not respond to it; it is a vertical thrust (up or down depending upon whether currents are antiparallel or parallel).

### D50 Currents, Magnets and Forces

(Do before Experiment 36)

This demonstration prepares students for Experiment 36, Currents, Magnets and Forces. A clear demonstration before the experiment will save time and point out some important observations that the students might otherwise overlook. The demonstration shows that there is a force between magnets and currents and establishes the relationship between the directions of current, magnetic field and force.

Students may have discovered some of this for themselves in the early part of Experiment 35\*.

#### Equipment

- 1 current balance with longest loop in place
- 1 power supply
- 1 ammeter (0-5 amp dc)
- 1 variac or 1 rheostat (5 ohm, 5 amp)
- 2 ceramic magnets on iron yoke
- 2 ceramic ring magnets, if possible. These can be any size, but should have center hole of at least  $\frac{1}{2}$ " diameter.
- wire leads
- 1 ring stand and test tube clamp

#### Procedure

Set up the current balance with the longest loop clipped to the balance beam. The current balance frame serves only as a convenient support for the balance beam in this demonstration. There will be no current in the fixed coils. Point this out at the beginning of the demonstration.

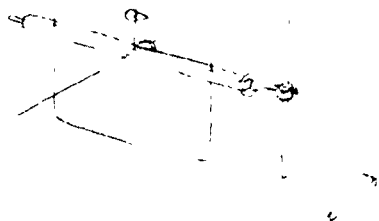

Connect the loop to the ammeter and power supply. Have either a rheostat in this circuit, or use a variac on the power supply.

Adjust the current to about 2-4 amps. The exact value is not important.

#### A. Current and Field Perpendicular

Place the magnet-pair on the current balance shelf so that the balance loop passes through the field.

Turn on the current and note the direction of the thrust.

The usual variations are possible. Show the effect of the following changes on the direction of the force:

1. Reverse the current by interchanging the leads to the balance.
2. Invert the magnet-pair
3. Reverse both the field and the current.

All the orientations studied so far will have caused a detectable force on the loop. Now turn the magnet-pair through  $90^\circ$  (magnetic field now horizontal), again making sure that the loop passes through the center of the field. There is no visible displacement of the loop. Is this because there is no force in this orientation, or is it because there is a force but in such a direction that it doesn't cause the pivoted loop to move? Remind students that this balance doesn't respond to vertical forces.

At this stage, if he has not already done so, the demonstrator must establish directions that describe the orientation of the current, magnets and force. The directions of the current and of the force are easily defined. If the students have not already been introduced to the idea of magnetic field, this is the time to do so. The important point at this stage is to establish the direction of the field. Using a small compass or iron filings, show that the field between the faces of two ceramic magnets is perpendicular to the faces.

Now we can go back and discuss the relative orientation of current, magnetic field and force in the different parts of the demonstration. Students should be able to see without too much difficulty that an inference of our demonstration, so far, is that when current and magnetic

## Demonstrations

D50

D51

D52

field are perpendicular to each other, the force on the current is mutually perpendicular to both. Teachers may, if they want, go on to develop a rule for the directions of current, field and thrust (e.g., the left-hand rule where I; current—index finger; first finger—field; thumb—thrust).

### B. Current and Field Parallel

With ring magnets you can demonstrate that there is no force on a wire if the current is along the direction of the magnetic field.

Disconnect one end of the magnesium loop, and slide the ring magnets, properly oriented to give a field (unlike poles facing) over the loop. Reconnect the loop.

Use a little putty to support the magnets on the shelf, a few inches apart.

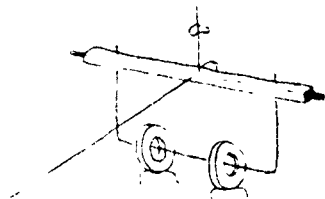

The distance is not critical and may depend on the size and strength of the rings. Adjust the balance loop so that the wire hangs freely in the center of the rings.

As current is switched on and off, the only effect on the balance will be a small one due to the earth's field (which can be avoided by adjusting the sensitivity to a minimum). If any deflection is observed, repeat the test without the magnets in position to show that the observed deflection was in fact due to the earth's field.

The inference of this demonstration is that with current and field parallel, there is no force on the current. (You may again want to show the direction of the field between these two magnets, using a small compass.) If students object that there may still be a force—but a vertical one and therefore undetected by our balance—invite them to find an orientation of current and field (while still keeping them parallel, of course) that does produce a horizontal force.

### C. The Interaction Between the Earth's Field and the Balance Loop

#### Procedure

Set the sensitivity to a maximum. (This probably means using two sensitivity clips, one at the top of the vertical rod, one midway; see Equipment Note.) Adjust the current in the balance loop

to 4 amps or so; turn it off. Set the balance to rest, and set the zero-mark level with the pointer arm; then turn on the current. The pointer deflects. Show that the deflection depends on the size of the current in the loop. Remind students that there is no current in the fixed coils.

Students already know that there is an interaction between magnets and currents, but there is no magnet near the current now, nor is there another current nearby. This deflection is caused by the earth's magnetic field.

### D51 Electric Fields

Mapping of an electric field can be done as follows: place a small glass tray on the stage of an overhead projector and fill it with water. Place the projector microammeter next to it. Connect a 45-volt battery to two electrodes in the water, and explore the electric field in the water with two wires connected to the microammeter. Equipotential lines are traced by seeking zero voltage positions; lines of force are traced by seeking maximum voltage positions. (The latter requires a constant distance between electrodes; a small loop of thread will do.) This can be done individually by putting a piece of white paper at the bottom of the tray and using pencils for electrodes.

The audio oscillator-amplifier with small loudspeakers can also be employed for an audio output.

### D52 Demonstrations and Experiments With Microwaves

(For details on operation of apparatus see Equipment Note, p. 81; see also Experiment 38\* for application of microwaves to communication.)

Because most classes will have only one set of microwave equipment these experiments have not been described in the Student Handbook. But some students at least should be given a chance to use the equipment and do for themselves the experiments described here.

The microwave region is intermediate between radio and light in the electromagnetic spectrum.

With a microwave oscillator and detector one can demonstrate the properties of electromagnetic radiation.

**Demonstrations  
D52**

Reflection, Transmission

Material	Reflection	Transmission
Metal	good	none
Wire screen	good	poor
Dry paper	no	yes
Wet paper	some	no
Human hand	some	no
Glass	some	some
Paraffin	some	some

Refraction can be shown by the focussing effect of a semi-cylindrical lens formed by allowing paraffin wax to solidify in a small juice can (Fig. 1).



Fig. 1

Standing Waves



Fig. 2

Explore the region between source and reflector. The distance between neighboring nodes (minima) is half a wavelength. From  $\lambda$  and  $c = 3 \times 10^8$  m/sec calculate  $f = \frac{c}{\lambda}$ . ( $f$  is about  $8 \times 10^9$  cycles per second.)

Diffraction

a) A narrow aluminum screen is provided. Place it 12 cm in front of the source. Explore the field 5 cm behind the screen and at greater distances. Observe the maximum in the center of the "shadow."

b) Mask one-half the source with the large screen placed about 12 cm in front of the source. Explore the intensity of the field as the detector is moved parallel to the screen and about 5 cm behind it. You might use the meter to record and plot intensity. You should be able to resolve at least two maxima. If the signal is weak, use the amplifier (connect diode to input, meter to output—see Equipment Note).

Note that the intensity at the first maximum is greater than when there is no screen present.

c) Use the two large screens to make a single slit about 10 cm in front of the source. The slit should be about 4 cm wide. Explore the region behind the slit.

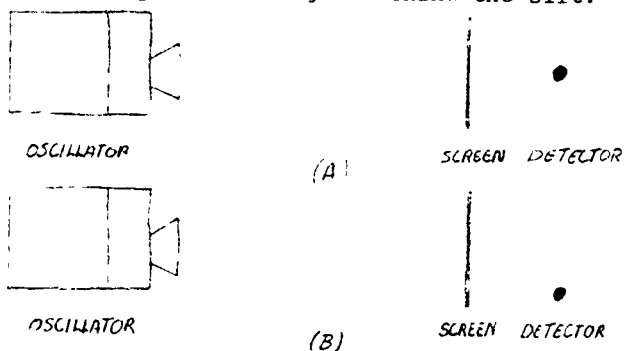

Fig. 3

Two-Source Interference

A two-source extension horn is supplied. Place the two-source extension over the horn of the generator. Explore the field about 25 cm in front of the two sources and plot the positions of maxima and minima. At least 3 maxima should be picked up on either side of the central one.

This method can be used to calculate wavelength. Use either the formula  $\lambda = \frac{xd}{z}$ , or the fact that any point on the first nodal line is one-half wavelength further from one source than the other:

$$S_1N_1 - S_2N_1 = \frac{\lambda}{2}$$

For the first (non-central) antinode (maximum) we have

$$S_1A_1 - S_2A_1 = \frac{2\lambda}{2}$$

and for the next node

$$S_1N_2 - S_2N_2 = \frac{3\lambda}{2}$$

etc.

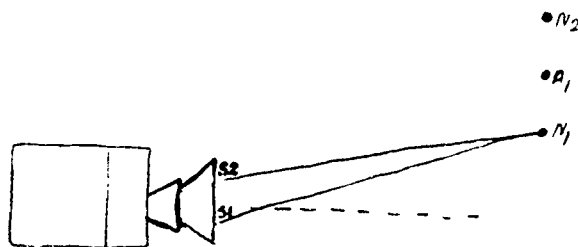

Lloyd's Mirror

In this variation of the two-source experiment, the source and its own image act as the two sources. It is much easier to demonstrate with microwaves than with light because the greater wavelength makes the adjustments less critical and the interference pattern larger.



Position the source and detector so that intensities of the direct and reflected radiation are about equal. Move the detector towards and away from the mirror, or keep the detector and source fixed and move the mirror.

The variation in total intensity at the detector is analogous to radio "fading." The metal reflector acts the part of the ionosphere (see Experiment #38\*).

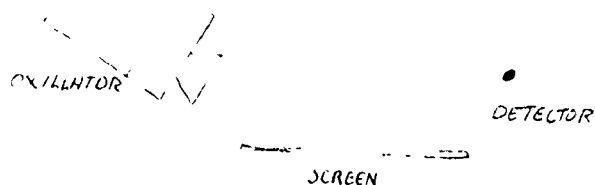

Fig. 5

You can demonstrate that the polarizer is in fact acting as a reflector by placing it at a slight angle and detecting the reflected radiation. When the copper strips are horizontal (perpendicular to the E field) electronic displacement is restricted and reflection is much less.

But not all polarizers work by reflection. An open hand, fingers vertical, acts as a good polarizer too. Here the radiation is partly absorbed, partly reflected. As the hand is rotated the transmitted signal increases and reaches a maximum when the fingers are horizontal.

Most polarizers of visible light ("Polaroid," tourmaline crystals, etc.) evidently work by absorption rather than reflection. These materials have a linear structure, similar in principle to our microwave polarizers, but on a much smaller scale.

For modulation of microwaves and application to communication, see Experiment 38\*.

### Polarization

It is much easier to demonstrate (and explain) polarization with microwaves than with light.

The radiation from the microwave generator is plane polarized, with the electric vector vertical. When the detector is held with the antenna vertical the signal is maximum: the (varying) vertical electric field causes movement of electrons up and down the antenna. As the antenna is rotated the effect decreases and disappears when the antenna is horizontal (perpendicular to the field).

A polarizer (copper strips plated on a piece of board) is provided. With the antenna held vertically, place the polarizer between it and the source. Rotate the polarizer about a horizontal axis: the signal is maximum when copper strips are horizontal and becomes zero when they are vertical.

Don't talk about picket fences or slots in pieces of card and rope waves at this state!

Why does the polarizer work to cut off radiation when the copper strips are parallel to the E field? In this orientation the varying E field causes a displacement of the electrons in the copper, just as it does in the vertical antenna. It is this displacement, induced by the radiation itself, that causes reflection of the radiation. It is because there are free electrons present in metals that they are better reflectors than non-metals, at light frequencies as well microwave frequencies.

#### L41: Standing Electromagnetic Waves

The intensity would go down inversely as the square of the distance if the radiating dipole were in free space. Because of the cavity the observed decrease of intensity is not as rapid as this.

Although the energy distribution inside the cavity is far from uniform in space, the total power (almost 20 watts) supplied by the transmitter is constant in time. The student might expect that when the standing wave exists in the cavity all or most of the reflected energy would be re-absorbed by the transmitter, reducing the net radiation required. This is true, but the meter reads the forward power, not the net power. Some of the power of the transmitter is used to balance losses of energy (the cavity is not closed on all sides). Also, some electromagnetic radiation is re-emitted in all directions by the receiving dipoles in which electrons are flowing.



**E32\*: Young's Experiment—Measuring the Wavelength of Light**

In this experiment a "showcase lamp" (e.g., Macalaster Scientific Cat. No. 1335, or from local stores) is probably best for classroom demonstration. The 6V automobile lamp from the Millikan apparatus can be used by small groups of students for this demonstration and for the experiment itself.

You might want to have students see diffraction of light from a point source by a circular aperture (pin prick in tin-foil or opaque paper). This is also suggested under "Some More Experiments" at the end of the student notes.

For a point light source you can use the small light source (AA cell and bulb) used for strobe photograph, or the Millikan light source viewed end-on.

To observe interference, not only must the light sources be small and close to each other, but the light waves that travel from the sources to any point P must have a sharply defined phase difference that remains constant with time. This essential condition, called coherence, is not mentioned in the student notes.

The cardboard tubes mentioned in the two-slit pattern observation are from the telescopic kit. Make sure to remove the objective lens!

The set-up shown in Fig. 2 is important. Any light that enters the tube except through the double slits will spoil the interference pattern. If the dark part of the film is not black use black tape or colloidal graphite to make it opaque.

One important feature of the experiment is that students do not need to work in a darkroom. The telescope tubes serve as individual darkrooms.

Earlier versions of the magnifier-with-scale will not fit into the narrow tube. They will fit into the wider tube; tape may be needed to give a snug fit.

In finding the wavelength of the transmitted light in Q4, the slit spacing  $d$  is about 0.2 mm. The students should remember that for any wave motion  $v = \lambda f$ .

Q6 Wavelength is too small for nodes, antinodes to be seen.

Q7 Because of short wavelength diffraction, effects are not usually noticed.

Contrast behavior of sound (wavelength about  $10^3$  greater) which "goes round corners" quite well.

Q8 The first one that comes to mind is the interference colors produced by a thin film (e.g., by reflection from an oil layer on a puddle) but students probably won't realize that this is an interference effect until you tell them. There is more on this in "suggestions for some more experiments."

In item 3 of "suggestions for some more experiments," glass flats work even better than clean microscope slides.

**E33\*: Electric Forces I**

Several important points that are not brought out in the experiment should be mentioned in discussion and, where possible, demonstrated by the instructor:

1. By "generation" of electric charge we really mean separation of charge. The two rubbed objects acquire equal and opposite amounts of charge. No new charge is created. This is demonstrated convincingly in D47. Indeed, electric charge should be added to the list of conserved quantities that have already been discussed: mass, momentum, energy.

2. Rubbing or "peeling off" is not the only way to separate electric charge. Charge can also be produced by heating and by shining light on the surface (demonstration D47). Chemical reactions (separation of charged ions by electrolysis) and radioactive reactions (emission of charged particles) should also be mentioned.

Several comments about experimental technique are also in order. On humid days the charged tapes may have to be replaced fairly often, since they will tend to discharge through the air. The surface of the table should be clean, dry and non greasy. It should also be smooth enough that the tape can be peeled off easily. If there are no such tables around, a glass plate or any hard plastic-covered surface will do equally well. One should always hold two tapes up with non-sticky sides facing each other, since they might otherwise stick together and alter each other's charge. Finally, it may often be helpful to fold over about  $\frac{1}{4}$ " of tape on one end before pasting it to the table. The non-sticky surface will make a convenient tab to pull up the tape by.

Experiments  
E33\*  
E34

Answers to Questions

- Q1 The reaction of the water strips should show that the tape is charged.
- Q2 The two tapes, if they are charged in identical ways, should have the same charge; they should therefore repel each other when held close together.
- Q3 The third tape, being charged, will interact with the other two. It will probably repel, and be repelled by, the first two. Of course if the first two tapes attracted each other the third will be attracted to one, and be repelled by the other.
- Q4 If the two tapes are properly peeled apart after being removed from the table, they should be oppositely charged, and should attract each other. Again, one should be careful not to get the tapes into a situation where they can stick together; peeling them apart would alter the charge.
- Q5 When each of the two tapes is brought near the original test strip (which may need replacement by now, especially on a damp day) one finds the test strip will attract one, repel the other of the separated pair of strips.
- Q6 The behavior of A and B differ in that any charged object that is attracted to A is repelled by B, and vice versa.
- Q6a All charged objects will fit into one or the other of these groups, namely "attracted to A" or "attracted to B." A and B are attracted to each other. Therefore, when making a table, A is placed in the "attracted to B" column, and B in the "attracted to A" column.
- Q8 The electric force is responsible for all these effects.
- Q9 The reasons for an attractive force always arising between a charged and an uncharged body are explained more fully in the text. For a more difficult puzzle that also depends on induction, demonstrate the electrophorus to students (see D48).

**E34: Electric Forces—Coulomb's Law**

Will the experiment work?\*

As in all electrostatics, the success of this experiment depends heavily on local conditions. Two factors should be considered:

First, the balance, of necessity, is a sensitive instrument: students need

\*You might have the PSSC film on Coulomb's Law (#0403 available from MLA) on hand, just in case. Running time: 30 min.

reasonable manual dexterity for this experiment than most of the others in the course. Students must work as a smooth team, both to reduce the time required for the experiment and to minimize air currents in the laboratory. A simple damping device, a pin moving in an oil bath, has been devised to reduce the annoying tendency of the balance to oscillate excessively.

The second condition that determines the probability of success is the rate at which charge leaks from the balls. Under extreme, usually unpredictable, conditions of dampness it will be impossible to carry out this experiment.

Local drying of the atmosphere may be possible in your laboratory.

a) Leave the steam heat on over the previous night. Success of the experiment may be worth the discomfort of a hot laboratory.

b) A large aquarium tank from your school's biology department, may allow you to perform the experiment as a demonstration-experiment inside a partially enclosed space. Dry this space with heat lamps, but start them well in advance of the period.

There are several methods available for measuring the small forces involved in this experiment. The balance used here has the particular merit that it does not require indirect geometrical calculations. As the students do the experiment, they have a real and obvious sense that they are measuring forces.

Alternative experiments on the force between charged bodies could be substituted here, of course (e.g., PSSC experiment IV-3, "The Force Between Two Charged Spheres"—equipment is Coulomb's Law Apparatus No. 1002, \$8.00 from Macalaster Scientific Corp.). That experiment, however involves resolution of forces, a topic that our students have not encountered. The experiment described here involves a simple balancing of forces, a technique that students will use again in the current balance and the electrolysis experiments.

You are urged to preassemble the equipment, if at all possible, to save classroom time. Even if students are to assemble the balances, parts should be prepared—plastic slivers cut, balls coated—before the lab period begins. Besides saving time, it may help to reduce the handling of these small bits of equipment. Caution students to touch slivers only by the ends, not by the center portion or the edges, and not to charge the slivers by rubbing them, etc.

Better success has been reported with the use of the milky white polyethylene

than with the clear plastic cut from electrostatic charging strips. Some teachers have successfully used plastic "drink sticks," toothpicks, etc.

Slivers should be about 5 cm long, pointed at one end. They must be clean and dry. The other end should fit snugly into a soda straw.

Although polyfoam balls have been used and are usually supplied by manufacturers, some teachers report greater success with pith balls.

It is important that the balls have a heavy coating of graphite in alcohol.

Student notes do not give directions for cutting the slivers or for painting the balls. If you want the students to perform these steps, you will have to give them directions, verbal or dittoed.

If the balls and slivers have been prepared ahead of time, they can be dried under a heat lamp or radiant heater. Do not overheat!

Almost any small plastic container will serve as the base for the balance. It should be about 3/4" to 1" across. Containers for Polaroid Print Coater work well.

The notches must be smooth if the balance is to swing freely.

Stray induced charges in the tabletop can ruin this experiment when the balance is too close to the table. The balance must be far enough above the table so that charging it will not result in a change in the horizontal balance position described in the student notes. How far this must be depends upon the local conditions, but 10 centimeters should be adequate. A book (or two) or a box or a plastic cup can be used as a base support (Fig. 1).

For damping, any slightly viscous liquid will do, such as glycerine, mineral oil, vacuum pump oil, etc. To prevent tipping, the container must be firmly taped to its base support.

A paddle—small piece of cord—on the vertical pin will further increase the damping. Lubricating the bearing with oil may help the balance to swing freely.

A larger charge will generally be obtained when charging is by induction rather than contact. Besides, "scraping" charge onto (or off) the balance ball can disrupt the balance. But students may not have had much information about "charging by induction." So it is not suggested in their instructions.

#### Measuring distances between the centers of the spheres

The induced charges in a ruler held

too close to the charged spheres will significantly influence the experimental results. Students are warned about this in their experiment notes, but no solution to the problem of good measurement is given. Many methods are possible, and it is hoped that students will come up with good ideas on their own. Here are two techniques that could be suggested.

1. The problem is to line up your eye, a sphere and a ruler scale over behind the sphere. Students may not be very familiar with parallax and the ways to reduce it. A mirror, handbag-size or a little larger, will do (try the local 5 and 10-cent store). Stick centimeter tape along the longer edge and stand the mirror in a vertical position about 5 cm behind the balance. When the charged sphere, or the sliver, lines up with its image in the mirror, parallax has been eliminated. This technique is often used with precision meters.

2. Centimeter tape can be stuck to the ring stand post. If the students record the position of the clamp at each step of the experiment, they can reset these positions when the experimental procedure is over and get the distance between centers of the spheres by direct measurement. At this stage it will not matter if the ruler is brought right up to the spheres.

Urge students to work smoothly but quickly. For example, let one record data while the other observes.

If students work from small to large forces (v charges closer as experiment proceeds), they will be following the student notes. If there is appreciable charge leakage during the minute or so required for the experiment, the results of a plot may be ambiguous. Usually, under these circumstances, the student's plot of  $F$  against  $1/d$  looks almost as linear as one of  $F$  against  $1/d^2$ .

However, if students proceed from large to small forces (moving charges from close up to farther apart), then the ambiguity is likely to be between  $F$  vs.  $1/d^2$  and  $F$  vs.  $1/d^3$ . You might ask half the class to reverse the order given in their experiment notes, but be sure to allow time for discussion so that students can compare results from both methods.

It is important to have the students perform the final part of the force vs. distance procedure as described in the student notes. If they have taken measurements while bringing the charges closer together, they must finish by removing one or two hooks and checking the separation required to reestablish balance. This measurement will probably not agree with their earlier data for

## Experiments

### E34

### E35\*

this number of weights. Of course, if the students have reversed the order and taken measurements while moving the charges farther apart, they will perform the "check" by adding a hook or two at a time and then comparing the balance position with a previous reading.

Only by actually performing this check will students observe directly just how serious the charge leakage has been.

Student notes do not suggest ways to decide what mathematical relationship best fits the experimental result. Suggestions for plotting were given in the notes on Behavior of Gases (E30), but you may have to suggest that they plot  $F$  against  $1/d$ ,  $F$  against  $1/d^2$ , etc.

With regard to question 8, each ball now has one half the original charge.

Students should find that removing three hooks (one left on) restores the balance better than removing two:

$$F = qq' / d^2$$

$$q' = \frac{1}{2}q$$

$$\therefore F = q(\frac{1}{2}q) / d^2 = \frac{1}{2}F$$

Students may be able to conclude that  $F \propto q_1q_2$ , though more experiments are needed to be sure of this.

#### Answers to questions

Induced charges will affect balance: see above.

Force law changes for small separations—we can no longer consider charge as concentrated at the center of sphere.

Suspend both balls so that they are free to move.

### E35\*: Currents and Forces

The current in the balance loop ( $I_b$ ) will interact with the earth's magnetic field. The magnitude of the force depends on the magnitude of  $I_b$ . (In the prototype balance, when  $I_b = 2.0$  amps and  $I_f = 0$ , the force was found to be balanced by the weight of 1 cm of #30 wire on the notch.)

The students' notes tell them to turn on  $I_b$  before they connect the fixed coil ( $I_f$ ). They may notice the slight deflection of the pointer, but its cause is not explained in the notes. Since the first part of the experiment should give the students some familiarity with the forces between magnets and currents, it may be best to wait until after that part to attempt an explanation.

The "balance-position" is marked with the zero-mark indicator when  $I_b$  is on, but  $I_f$  is not. In this way, the gravitational forces on the balance itself compensate for the earth's magnetic effect. Of course the zero-mark must be adjusted if  $I_b$  is changed. This is one good reason for using a null method for balancing. The data obtainable with this apparatus are actually quite good. We append a sample report to give an idea of the sort of results that can be expected.

A. Group A is expected to report that  $F = I_f$ . Lead the class to accept the argument, from symmetry, that  $F = I_b$  also.

After all, the fixed loop could have been made to move, and the balance loop could have been held fixed; the experiment would have been the same—only the equipment would have been modified.

Thus Group A reports  $F = I_f$  and  $F \propto I_b$

Students may get confused, hold  $I_f$  constant, and vary  $I_b$ . Since the force on the balance due to the earth's field increases with  $I_b$ , the effect is not a constant. A plot of  $F$  vs.  $I_b$  will not be linear, although it will pass through the origin.

B. Group B reports  $F = 1/d$ .

The fixed loop consists of a bundle of wires; the location of the "center" is assumed to be the geometric center.

Students are directed to obtain data for values of  $d$  from about 0.5 cm to 5.5 or 6.0 cm. Keep in mind that, for  $d = 0.5$  cm, an uncertainty in measurement of only 0.1 cm represents 20%.

Since the balance is moved between readings, students must recheck the position of the zero mark every time. These readjustments are critical.

Students should plot  $F$  against  $d$ . The  $F$  vs.  $d$  curve should suggest that the form of the relationship may be  $F \propto \frac{1}{d}$ . If students next plot  $F$  against  $\frac{1}{d}$ , they will get a straight line. For small values of  $d$  (large  $\frac{1}{d}$ ) where the uncertainty is large, there may be noticeable deviation from a straight line.

C. Group C reports  $F \propto d$ .

In this part of the experiment the actual distance between the loops and wires is not critical. (It must, of course, be the same for all measurements.) It must

be small enough, however, so that there will be a reasonable force on the shortest loop for the currents and distance used. In a trial with the prototype balance, currents of about 4 amps were used. The shortest loop, at a distance of 1.5 cm, gave a force equivalent to only 3.5 cm of #30 wire. Since the balance is responsive only to about ±0.5 cm of #30 wire, the uncertainty in this 3.5 cm value was ±14%.

The results of the three groups combine to give:

$$F \propto \frac{I_f I_b^2}{d} \text{ or } F = \frac{K' I_f I_b^2}{d}$$

A possible extension of this series of experiments is the determination of the constant  $k'$  (Q14). The force  $F$  must be converted from centimeters of wire into weight of wire, and the weight of wire expressed in newtons. The balance is constructed so that the horizontal part of the loop and the notch on which weights are hung are equidistant from the pivot, i.e., the two torques are equal, therefore the forces are also equal. (The value of  $k'$  is defined  $2 \times 10^{-7}$  newton/amp<sup>2</sup>; it serves to define the ampere.)

This constant is related to the constant in Coulomb's law  $F = k \frac{q_1 q_2}{d^2}$  and the velocity of light,  $C$ :

$$C^2 = \frac{2k}{k'}$$

The value of the coulomb law constant  $k = 9 \times 10^9 \text{ N}\cdot\text{m}^2/\text{coul}^2$  was given in Sec. 14.

Students will probably be intrigued to find this familiar number ( $C = c \times 10^2 \text{ m/s}$ ) cropping up in an apparently unrelated field. If you do bring out this point we suggest that rather than try to explain it you let it stand as the first clue that there is a connection between electricity, magnetism and light. This connection is brought out in the discussion of Maxwell's work in Chapter 16.

SAMPLE DATA OBTAINED USING PROTOTYPE CURRENT BALANCE

A.  $F$  vs.  $I_f$

$$d = 1.75 - 0.25 = 1.50 \text{ cm}$$

$$I_b = 3.0 \text{ amps}$$

maximum sensitivity

F	$I_f$
2 cm #30 wire	0.6 amps
6	1.7
8	2.3
10	2.9
12	3.3
14	3.9
16	4.5
18	5.1
20	5.6?

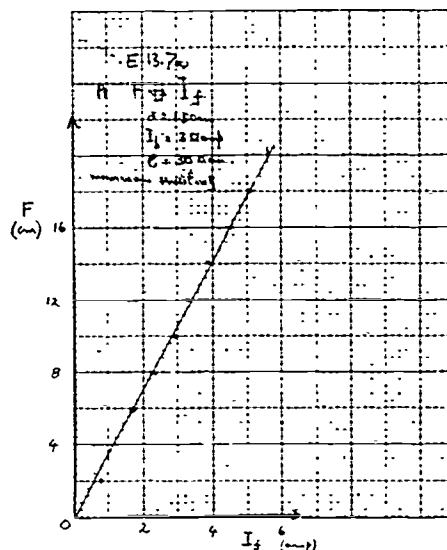

B.  $F$  vs.  $d$

Used mirror and plastic cm tape, for parallax-free scale.

Wire radius = 0.1 cm.

Fixed loop diam. = 0.3 cm, so  $r = 0.15$  cm.

If measure position of inner edge of balance loop

distance =  $d + 0.1 - 0.15 = (d - 0.05)$  cm

Added  $F = 20$  cm, set  $d = 0.65$ , adjusted currents: set at max. sensitivity  $I_f = 2.75$  amp,  $I_b = 2.7$  amp

$d - 0.05$ = dist	$1/d$	F	$1/F$
0.6 cm	1.7	20	0.05
0.9	1.1	15.5	0.065
1.2	0.83	11.5	0.087
1.65	0.60	9	0.11
2.15	0.46	7	0.14
2.75	0.36	5.5	0.18
3.25	0.31	5	0.20
3.8	0.26	4.5	0.225
4.7	0.21	4	0.25
6.25	0.16	2.5	0.40



Experiments  
E35\*  
E36

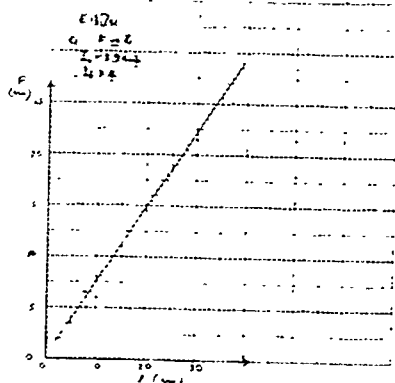
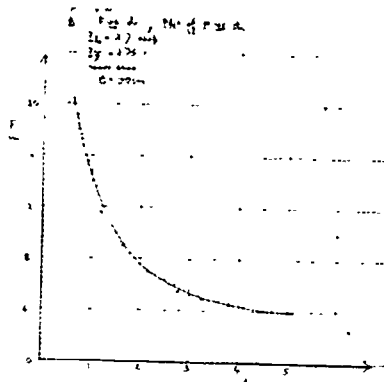

Note that in this experiment the zero-mark was set with no current in the balance loop. This accounts for the finite intercept on the F axis, which represents the force on the balance loop current due to the earth's magnetic field. If the zero-mark had been set with the current to be used in the experiment in the balance loop, then the F vs.  $1/d$  plot would pass through the origin.

C. F vs. . .

Set at intermediate distance 1.55 cm between inner edges.

Added F = 20 cm      $\rho = 29.7$  cm  
Adjusted currents  $I_c = 4.1$  amp

$I_b = 3.9$  amp

$\rho = 16.1$  cm

Adjust (a) loop parallel to fixed wire and horizontal

(b) sensitivity

(c) balance point

Adjust current

$\rho = 7.8$  cm     F = 6.5 cm

$\rho = 4.8$  cm     F = 3.5 cm

Plot: good except for first, long loop.

1. Reset; found loop not quite horizontal with fixed loop. It was about 2 mm high,  $\therefore$  low torque  $\therefore$  low force.
2. Made new loop! Was now horizontal. Got F = 21.5 cm for  $\rho = 30.0$  cm. A little better—within reasonable limits.

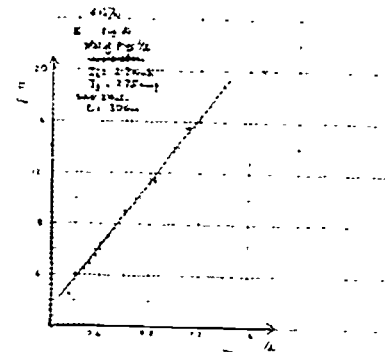

E36: Currents, Magnets and Forces

If students seem initially to be in trouble, a likely cause is that they have set their magnets on the yoke in such a way that like, instead of unlike, poles are facing.

Groups A and B are not told to compensate for the earth's interaction with current. This is because the vertical component of the earth's field is very small compared with the field between a pair of the ceramic magnets supplied (about  $0.8 \cdot 10^{-4}$ , as compared to about  $300 \cdot 10^{-4}$  weber/meter)—a fact which students who raise the question can very quickly check for themselves.

The forces here are much greater than in Experiment 35, Currents and Forces. Students who finish parts A and/or B quickly could be encouraged to go on to C—quantitative measurement of the vertical component of the earth's field.

Part C is probably the most demanding of the current balance experiments and should be assigned to your more able students. The forces to be measured are small, and a calculation is required.

Students measure (in terms of the weight, or number of centimeters of wire) the force needed to restore balance with a current in the balance loop alone: no current in the fixed wires, and no other magnets nearby. They should work at maximum sensitivity. Let them repeat the measurements for several values of  $I_b$ .

Someone may raise the question: isn't the orientation of the loop, with respect to the earth's field, important? Students should be able to answer this from the previous demonstration. If there is time, let them try to detect an effect. [The point is that the interaction between the vertical component of the earth's field and the horizontal current

will always give the same horizontal force, perpendicular to the current. The horizontal component of the earth's field will interact with the horizontal current (unless the two are parallel) to produce a vertical force. But the current balance doesn't respond to vertical forces. See also "Orientation of Current Balance Unimportant" in the equipment note printed in the Equipment Section of this Teacher Guide.]

They must convert the force from cms of wire into newtons, either by weighing the wire, or by looking up the mass per unit length of the wire used (#30 copper: 0.45 grams/meter. One gram =  $10^{-3}$  kg =  $10^{-3} \cdot 9.8$  newtons). Although students in Project Physics have not studied levers or torques, their experience with seesaws or their work in elementary science courses should enable them to see that the system in the figure will balance when:

$$F a_1 = W a_2$$

$$F = W \frac{a_2}{a_1}$$

(From measurement they will probably find that  $a_1 = a_2$ .)

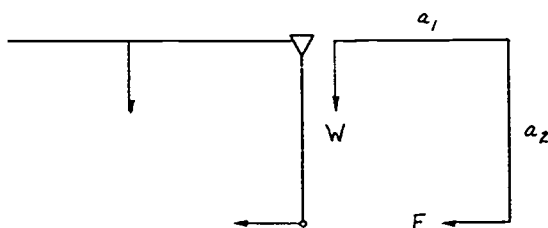

This is the force on the current. Students are asked to find the force on a wire one meter long when the current is one amp. This is the magnetic field (B) in MKSA units:

$$B = F/I$$

$$B = \frac{W \frac{a_2}{a_1}}{I \cdot l}$$

### Conclusions

Group A is expected to report that  $F \propto I$ . Group B should report that  $F \propto l$ . These two statements can be combined to give  $F \propto Il$ . What other factors affect the force? Both groups will realize that if they had used "stronger" magnets they would have found greater forces, for the same values of  $I$  and  $l$ . So in this case we are not looking for a proportionality constant but for a factor that describes or measures the strength

of the magnetic field.

We define the magnetic field strength  $B$ , by  $F = BIl$ .  $B$  is therefore equal to  $\frac{F}{Il}$ ; it is the force, in newtons, on a conductor one meter long, carrying a current of one amp.\*

Group C measured the force on the loop due to the vertical component of the earth's magnetic field. To calculate  $B_{\text{vert}}$  in standard units they

must use  $B = \frac{F}{Il}$ . (In Massachusetts

$B_{\text{vert}}$  is about  $0.7 \cdot 10^{-4}$  newton/amp meter.)

By comparing the two equations that were obtained in the two current balance experiments,

$$F = k' \frac{I_1 I_2 l}{d} \text{ and } F = BIl$$

We can see that the magnetic field at a distance  $d$  from a straight wire carrying a current  $I$  is  $\frac{kI}{d}$

### Sample Results

E36 Currents, Magnets and Forces

A. F vs. I

2 ceramic magnets on iron yoke

$I_b$	F
2.1	40 cm #30 wire
4.0	80 cm #30 wire

$$F \propto I$$

Measurement of Earth's Field:

Current in balance loop only.

$I_b = 4.0$  amp ;  $l = 30$  cm (longest loop)

$F = 2$  cm of #30 wire

Wire has mass of 0.45 g/meter

$\therefore 2$  cm weigh  $0.45 \cdot 0.02 = 0.009$  g

$W = mg = 0.009 \cdot 10^{-3} \cdot 9.8$  newton  
 $= 8.8 \cdot 10^{-5}$  newton

Lever arm lengths are equal

$\therefore F = W = 8.8 \cdot 10^{-5}$  newton  
 $F = BI l$

$$\therefore B = \frac{8.8 \cdot 10^{-5}}{4 \cdot 0.3} \text{ mks units}$$

$$= 0.73 \cdot 10^{-4} \text{ weber/sq meter}$$

$$(0.73 \text{ gauss}).$$

\*Note that 1 newton/amp meter

$$1 \text{ weber/meter}^2 = 10^4 \text{ gauss}$$

Experiments  
E36  
E37

SAMPLE RESULTS FOR EXPERIMENT 36

- A. F vs. I  
single magnet; each hook is 2.5 cm  
#20 wire; sensitivity—minimum.  
Conclusion:  $F \propto I$

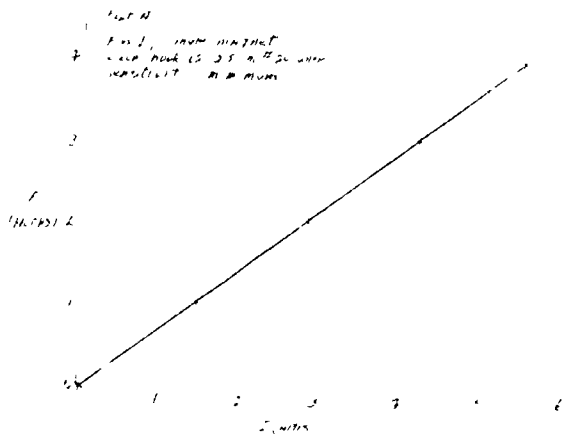

- B. Made three magnets—each is a pair of ceramic magnets on an iron yoke.  
Used 2.5 cm long hooks of #20 copper wire as weights.

3 amps in balance loop; no current in fixed coil.

How does F depend on  $i$ ?

- a) compare magnets, one at a time:  
#1, 2 × 2.5 cm #20 wire to balance  
#2, 2 × 2.5 cm \_\_\_\_\_  
#3, 2 × 2.5 cm \_\_\_\_\_

- b) two magnets:  
#1 and #2, 4 × 2.5 cm #20 wire to balance  
#1 and #3, 4 × 2.5 cm \_\_\_\_\_  
#2 and #3, 4 × 2.5 cm \_\_\_\_\_

- c) all three magnets together:  
#1 and #2 and #3, 6 × 2.5 cm #20 wire to balance.

Conclusion: F varies linearly with number of magnets interacting with current. Since magnets are far from each other and all have the same strength  $F \propto i$ .

- C. Effect of earth's field.  
Current in balance loop only.

$$I_b = 4.0 \text{ amp}$$

$$l = 30 \text{ cm (longest loop)}$$

$$F = 2 \text{ cm of #30 wire}$$

Wire has mass of 0.45 g/meter.

$$\therefore 2 \text{ cm weigh } 0.45 \times 0.02 = 0.009 \text{ g}$$

$$W = mg = 0.009 \times 10^{-3} \times 9.8 \text{ newton}$$

$$= 8.8 \times 10^{-5} \text{ newton}$$

Lever arm lengths are equal.

$$\therefore F = W = 8.8 \times 10^{-5} \text{ newton}$$

$$F = BI l$$

$$\therefore B = \frac{8.8 \times 10^{-5}}{4 \times 0.3} \text{ mks units}$$

$$= 0.73 \times 10^{-4} \text{ weber/sq meter}$$

$$(= 0.73 \text{ gauss}).$$

E37: Electron Beam Tube

The most common cause of failure in this experiment is a poor vacuum pump. A carefully constructed tube used with a moderately good rotary vacuum pump (giving a pressure of 40 microns of mercury or less), should give a fairly well-defined visible beam a few centimeters long which can easily be deflected in electric and magnetic fields.

Condensed vapors (e.g., water) in the pump oil cause lower pumping speeds, poorer ultimate vacuum, and may lead to corrosion of the pump. If your pump has not had adequate maintenance, change the oil. Then "run in" the new oil by pumping on a closed system for a little while.

Since you will probably only have one "operating station" (vacuum pump, power supplies, etc.) students will have to test their tubes one at a time. The first group of students who get their tube to work could demonstrate it to the rest of the class, so that all students will get a chance to see at least one tube in operation.

You might want to mention the cathode-ray tube and the television picture tube. The sensitive coating on the screen (inside) glows where it is struck by the electron beam. As the beam is moved, by electric or magnetic fields, the bright spot on the screen moves. A uniform field will be seen to be important again in the Millikan Experiment (E40) in Unit 5.

The assembly instructions should be self-explanatory; the only tool needed is a pair of wire cutters. It usually takes a student 30-40 minutes to assemble his tube. You may find it possible to have students do the assembly at home. But they should probably bring their assembled tubes to school before sealing them; it is important that the tube be undisturbed while the sealant is drying.



A spare filament is provided in each kit; if the filament does burn out, the tube can be remade, using the spare. It is also possible, using one of the spare leads, to mount two filaments in one tube (Fig. 1). Then if one filament burns out, the tube does not need to be taken apart to mount another.



Fig. 1

But if this is attempted, one must be very careful about the alignment of the filaments with the hole in the anode cap.

If you need more support tubes, get very thin aluminum tubing, obtainable at hobby shops.

If you do not get a visible glow, do not be shy of increasing the filament current to 5 amps or more: a burnt-out filament is no worse than a tube that does not function for some other reason. A skewed beam is probably caused by poor alignment of the filament and anode hole.

After about 10 minutes or more of operation, the beam may become less intense; apparently the coating on the filament deteriorates.

#### Electrostatic deflection

With anode plate and deflecting plate at the same potential, i.e., with deflecting plate and anode connected to the same battery terminal, the beam should be equidistant from both plates. (If it is not, this is almost certainly because the filament and anode hole are not lined up properly, giving a skewed beam.) Try the effect of changing the potential of the deflecting plate—say 50 volts above or below anode potential. Do this at various anode potentials; the lower the anode potential, the slower the electrons in the beam, and the easier they are to deflect.

If batteries are used to supply the anode and deflecting potentials, they should be big ones—such as Burgess No. 2308 45-volt "B" batteries. Alternatively use the Linco Power Supply (7100) or Macalaster (MSC 2105). Always include rheostat and ammeter in filament circuit.

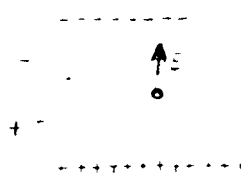

Electric field points towards negative plate (direction of force on positive test charge). Beam is deflected in opposite direction (towards + plate), so its charge is -.

#### Magnetic deflection

Use the two magnets and yoke from the current balance kit to provide a (fairly uniform) magnetic field. The electron beam is bent into a more or less circular arc, in a plane perpendicular to the magnetic field. The force on the moving particles is perpendicular to their direction of motion and to the field. Reverse the field—what happens to the force on the particles?

Electric and magnetic fields must be perpendicular to each other for the two effects to cancel.

### E38\*: Waves, Modulation, Communication

#### Introduction

This "experiment" has been designed differently from the others in the course. It is really a series of demonstrations using turntable oscillators, tuned circuits and microwave equipment, to be followed by student experimentation with the same equipment. It should tie together much of the material on waves and electromagnetism in Units 3 and 4, and indicate its relevance to communications.

The student notes do not give much detailed instruction about the operation of the equipment; it is assumed that they are fairly familiar with it from the demonstrations.

You may not have time to do all these demonstrations in class, as part of this experiment. In any case students may want to repeat some of the demonstrations for themselves before going on to the new investigation described in their notes.

#### A. TURNTABLE OSCILLATORS

Waves are generated by an oscillator: ripple-tank waves by an oscillating object at the surface; sound waves by an oscillating diaphragm, string, or air column; radio waves by oscillating electric charge, etc. The back-and-forth motion of the pen attached to a turntable oscillator provides a simple way of seeing how the oscillation is related to the wave. (And incidentally is also an illustration of the relationships between circular motion and simple harmonic motion and sinusoidal waves.) As a wave passes a

Experiment  
E38\*

point in space some quantity—height of water, pressure of air, electric field, etc.—at that point varies with time. On the turntable oscillators the variation of the pen's position with time is recorded by a paper chart moving under it at uniform speed. As well as a record of the variation with time of the disturbance at a given point the trace is also a "snapshot" of the wave at a particular instant which shows how amplitude varies with position.

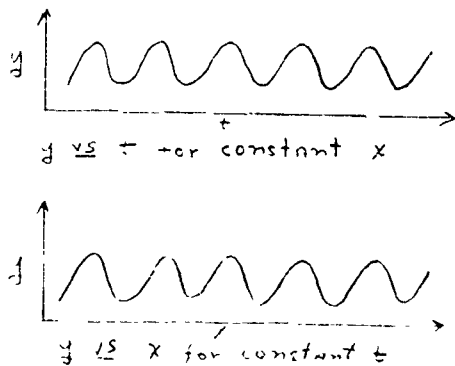

The simplest way of using a wave phenomenon to communicate is just to turn the signal on and off according to some prearranged code. A buzzer or light beam can be turned on and off to give a series of long and short "dots and dashes" as in Morse code. Turning the signal abruptly on and off is a primitive form of amplitude modulation. A more sophisticated form of amplitude modulation in which the strength of the signal is varied continuously makes it possible to convey more information.

The amplitude ("strength") of the signal made by the turntable oscillator depends on the distance of the vertical post from the center of the turntable. It is possible, though not easy, to change its position, and thus produce amplitude modulation while the oscillator is working. Set the turntable to its lowest speed (16 rpm). You won't be able to make a very neat trace this way, but it will give an idea of what an amplitude-modulated wave looks like.

Demonstration of amplitude modulation

Set up a pair of turntable oscillators so that the pen attached to oscillator A writes on the strip-chart recorder ("drag-strip") mounted on oscillator B (Fig. 1).

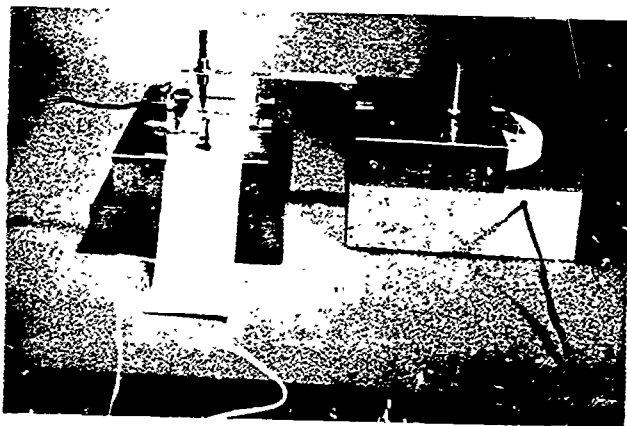

Fig. 1 Two oscillators, A, writing on recorder mounted on B.

Turn on oscillator A, and if necessary adjust the equipment so that the pen stays on the paper. Now turn on the chart recorder to get a record of the pen's position as a function of time. Slow the effect of changing the frequency of the oscillator by changing the turntable speed.

Demonstrate oscillations of different amplitude by changing the position of the vertical post on the turntable.

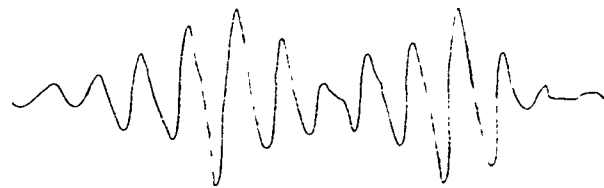

Fig. 2 Hand produced "amplitude modulation."

The same effect can be produced by adding together the output of two oscillators. (The demonstration of beats was probably done in Unit 3; for details see Teacher Guide p. 98, D46.) Both oscillators are switched on and are oscillating at slightly different frequencies. The

resulting trace will be an amplitude-modulated sine curve.\*

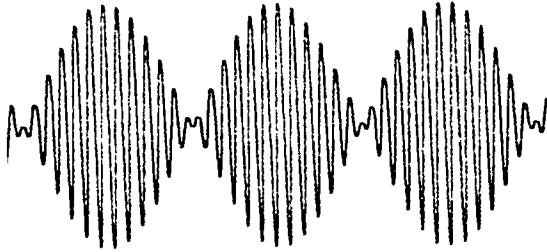

Fig. 3 Amplitude modulated sine curve.

\*Beats and amplitude modulation are mathematically equivalent: beats are the result of the addition of two sinusoidal waves.

$$A = A_1 + A_2 = \cos 2\pi f_1 t + \cos 2\pi f_2 t \quad (1)$$

$$= 2 \cos 2\pi \frac{f_1 - f_2}{2} t \cos 2\pi \frac{f_1 + f_2}{2} t$$

If the two frequencies  $f_1$  and  $f_2$  are nearly equal the difference  $|f_1 - f_2|$  will be small. The beat frequency is

$$\left| \frac{f_1 - f_2}{2} \right|$$

In amplitude modulation the amplitude of a high frequency oscillation ( $\cos 2\pi f_c t$ , the "carrier") is varied at a much lower rate (signal frequency). In the simplest case the signal is also sinusoidal ( $\cos 2\pi f_s t$ ), and so the result is:

$$A = \cos 2\pi f_s t \cos 2\pi f_c t \quad (2)$$

Equations (1) and (2) have the same form: the carrier frequency  $f_c$  is analogous to the mean frequency

$$\frac{f_1 + f_2}{2}$$

and the signal frequency  $f_s$  to the beat frequency

$$\left| \frac{f_1 - f_2}{2} \right|$$

(Before attempting this demonstration turn both turntables by hand to make sure that the pen will not leave the recording paper when the amplitude of the resultant trace reaches its maximum value.)

You can vary the frequency of the modulation by changing slightly the frequency difference between the two oscillators. This is most easily done by reducing slightly the voltage to one with a "Variac" or "Powerstat" in the line, or by loading down one of the platters.

#### Not all waves are sinusoidal

Although simple harmonic oscillators and sinusoidal waves are rather common they are by no means the only ones possible. You can use an oscilloscope to demonstrate that the sound waves produced by different musical instruments playing the same note can have quite widely different shapes (see Teacher Guide for Unit 1, page 119). But any complex wave form can be produced by adding simple sinusoidal waves (Fourier synthesis). This can be demonstrated with the turntable oscillators. Turn both on, but at different frequencies; say one at 16 rpm and the other at 45, or 33 rpm and 78, etc. The amplitudes can be varied as well as the frequencies of the two oscillations. The resulting trace will be a complex but regular pattern that repeats itself periodically.

One particularly interesting case is the "square wave." The sinusoidal components that combine to form a square wave are

$$\sin \omega t + \frac{1}{3} \sin 3\omega t + \frac{1}{5} \sin 5\omega t + \dots$$

The first two terms can be added using a pair of turntable oscillators. Some care is needed to get the frequency ratio 1:3, the amplitude ratio of 1:1/3, and the two in phase (Fig. 4).



Fig. 4  $\sin x + \frac{1}{3} \sin 3x$

#### Relevance to communication

The connection between amplitude modulation and communication will become more apparent in the next two demonstrations. To anticipate a little, it is briefly this: a radio station emits high frequency electromagnetic radiation at some particular frequency, say 1000 kilocycles per second. The electrical circuits at the station maintain a steady oscillation at this frequency. (Different station, different frequencies, of course.)

Someone in the studio plays or sings a note, say middle C, into a microphone. The characteristic pressure fluctuations

Experiments  
E38\*

caused by his voice (in this case at 256 cycles per second) are transformed into electrical signals at the same frequency which vary the amplitude of the 1000 kc/sec oscillation. So a 1000 kc/sec oscillation modulated at 256 cycles/sec is transmitted.

At the receiver (tuned to pick up oscillations at 1000 kc/sec) the process is reversed and the 256 cycle per second signal is recovered, fed into a loud-speaker which sets up pressure fluctuations at 256 cycles per second, which we hear as middle C.

B. TUNED CIRCUITS

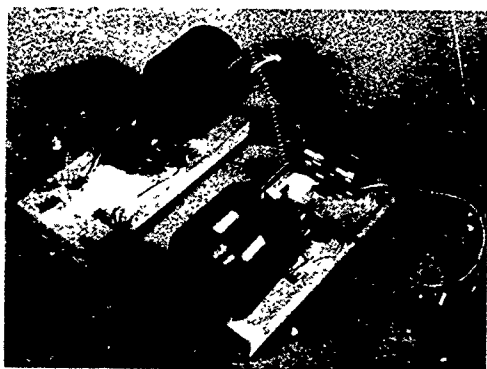

Fig. 5

With two circuits each consisting of a coil (about  $5 \times 10^{-4}$  henrie) and a variable capacitor ( $10 \times 10^{-12}$  to  $365 \times 10^{-12}$  farad) you can demonstrate many of the phenomena related to "wireless" communication. Use the Fahnstock clips to disconnect any part of the circuit not needed in a particular demonstration (e.g., take the capacitor out of the circuit for the first two demonstrations).

1. Changing Magnetic Field Produces Electric Field

a) Connect one coil directly across oscilloscope. Set the oscilloscope gain to maximum. Move a magnet in and out of the coil. The oscilloscope beam shows a deflection only when the magnet is moving, and the faster the movement the greater the deflection. Almost any magnet will do, but if you use a powerful one, keep it far enough from the scope to prevent it from affecting the beam directly.

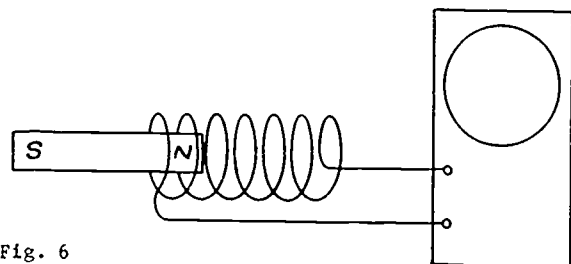

Fig. 6

Instead of the oscilloscope you can of course use a galvanometer to show the induced current, or the Project Physics amplifier and projection millioammeter.

b) Use the second coil to produce the magnetic field: the oscilloscope beam remains undeflected for either no current or steady current in the left-hand circuit, i.e., steady magnetic field. But if the magnetic field changes, owing to "make" or "break" of the left-hand circuit, a current is induced in the right-hand circuit, and the oscilloscope beam is deflected. Try to open and close the left-hand circuit as cleanly as possible. don't scrape the saw blade in this demonstration.

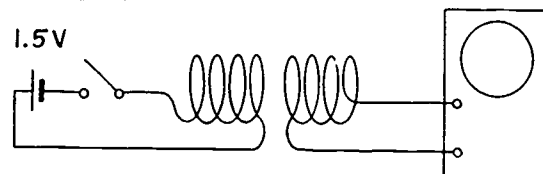

Fig. 7

You may wish to explore the effects of changing the position of one of the coils, adding iron cores, screens of various materials between the two coils, etc., on the voltage induced in the right-hand circuit (as shown on the oscilloscope) when the left-hand circuit is opened and closed.

2. Resonance in Electrical Circuits

Connect the circuit as shown:

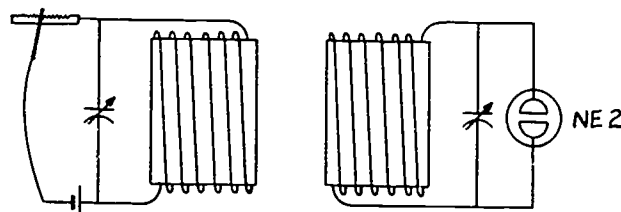

Fig. 8

when contact is broken in the left-hand circuit, oscillations are set up. (A simple exposition of the oscillatory flow of charge in an LC circuit is given in many texts\*; the usual mechanical analogies—mass-on-spring, pendulum, etc.—are helpful.) Because of resistive and radiative loss of energy the oscillations die away quite quickly, and so it is necessary to make and break contact repeatedly by scraping the contact wire on the saw blade.

If the coil or the second circuit is

\*e.g., PSSC, Chapter 31; Dull, Metcalfe and Williams, Chapter 25; Lehrman and Swartz, Chapter 16; Sears, Zemansky, Chapter 36.

placed close to the first coil—axes aligned as shown in the diagram—the oscillating magnetic field of the first will induce an oscillating current in the second. But only if the natural frequencies of the two circuits (each

given by  $f = \frac{1}{2\pi\sqrt{LC}}$ ) are the same will

large oscillations build up in the second one. Set the capacitor in the first circuit ("transmitter") to a particular capacitance  $C_1$ . Vary the capacitance  $C_2$  of the capacitor in the second ("receiver") circuit while scraping the contact wire. When  $C_1 = C_2$ , electrical oscillations

build up in the "receiving" circuit and the neon bulb glows. The demonstration probably won't work if you touch the bare part of the copper scraper wire—pick it up by the insulated part only.

The neon bulb requires about 70 volts to make it glow, and yet it can glow with only a  $1\frac{1}{2}$  volt battery in the "transmitting" circuit. This is because the electric field induced depends on the rate of change of magnetic field. In this case the voltage induced in the "receiver" depends on the rate of change of current in the "transmitting" circuit.

Some mention of other resonant systems should be made—e.g., a child on a swing, driven pendulums, etc. (analogous to our "receiver" circuit) can only build up big oscillations if energy is fed to them at their own natural frequency.

The values of L and C are chosen so that the frequency range of these oscillations is in the broadcast range (550 to 1500 kilocycles). This can be shown by picking up the signal from the "transmitting" oscillator on a regular or transistor radio set. A radio has a frequency sensitive circuit which is tuned in just the same way as our primitive "receiving circuit." Turn on the radio and tune it to some frequency near the low frequency end, and where no broadcasting station is picked up. The radio should be several meters from the "transmitter," volume control turned up. Scrape the "transmitter" contact and vary the capacitor until a loud scraping sound is heard in the radio. The electrical energy of the oscillations in the demonstration "receiving" circuit caused the neon bulb to glow: in the radio some of the energy is used to control the circuits responsible for audible sound. With the radio tuned to a different frequency, another setting of the variable capacitor in the "transmitter" is required. Or set the "transmitter" and tune the radio to the "transmitter" frequency. Because our primitive LC circuit has a fairly wide resonance maximum (low Q),

some noise will be heard even if the radio or "transmitter" is somewhat "mistuned."

### 3. Further Investigation of the Oscillations in a Resonant Circuit

The oscillations themselves can be demonstrated as follows:

Instead of scraping to provide repeated make-and-break contact, use a signal generator (audio oscillator), set to "square wave," to provide a succession of regular pulses.\* First connect the signal generator directly to an oscilloscope and show the wave form it produces.

Now connect the signal generator across the coil and capacitor of the "transmitting" circuit. Connect oscilloscope across coil and capacitor to show the electrical oscillations in this circuit.

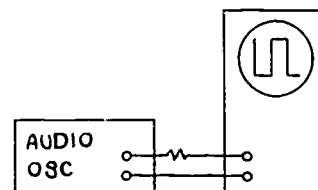

25 kc/s  
SQUARE WAVE

\*The old (1967-68) Project Physics amplifier can be used as a square-wave generator in either of two ways:

a) Connect a capacitor between the input and output terminals of the amplifier (note that the oscillator plug-in unit is not used).

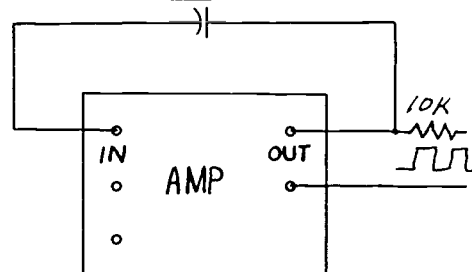

The frequency of the square-wave signal appearing between the output terminals depends on the capacitance in the feedback line and to some extent on the setting of the gain control. With a capacitance of  $0.0001 \mu\text{f}$  the square-wave frequency can be adjusted between about 65 kc/sec (gain setting zero), and 23 kc/sec (gain 100). For 25 kc/sec set the gain control to about 50.

Connect to the LC circuit via a 10K resistor.

(Footnote continued on next page.)



Experiments  
E38\*

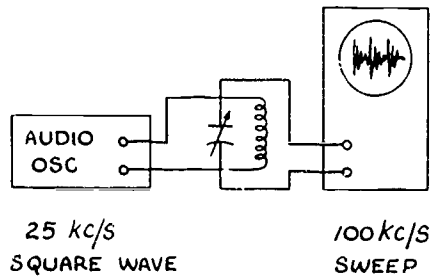

Fig. 10

Notice how the oscillations decay while the voltage supplied by the square-wave generator is steady and are reestablished every time the voltage changes sharply.

Now bring the "receiving" circuit near, transfer the oscilloscope leads to it, and tune the circuit to resonance. (Note that by connecting the signal generator to one circuit and the oscilloscope to the other, we have added different impedances to each. This is why the same capacitor settings in each circuit may no longer necessarily give the same tuning as before.)

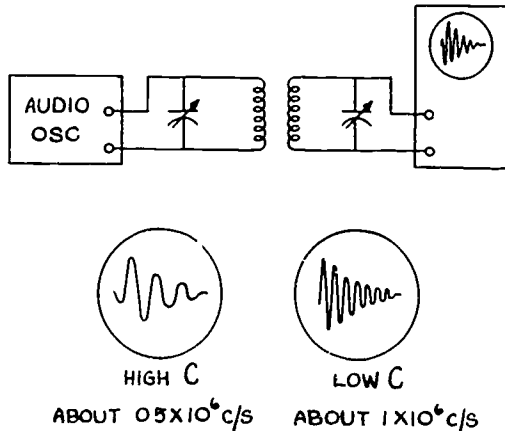

Fig. 11

\*Footnote continued

b) Connect the oscillator plug-in unit and set the gain to 100. The amplifier output is a clipped sine wave, which is a good approximation to a square wave. Adjust the frequency in the usual way with the oscillator unit.

Connect to the LC circuit via a 15K resistor,



set gain to maximum and dc offset to zero.

Electrical oscillations are observed in the second circuit. As the resonant frequency is changed (i.e., both capacitors varied), the number of oscillations in the resonant circuit per period of the square-wave signal will vary.

4. Damping

Add a 0 to 1 K variable resistor to the receiver circuit; as the resistance is increased, the oscillations decay more rapidly.

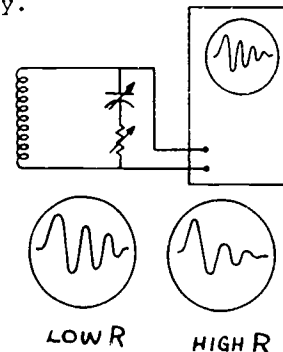

Fig. 12

5. Use of Tuned LC Circuit as Radio Receiver

We showed in one of the earlier demonstrations in this sequence that the signal generated by the transmitting circuit can be picked up by a radio. In this demonstration we do the reverse: we use the LC circuit to pick up the signal broadcast by a local radio transmitter.

Connect an antenna (a long piece of hookup wire, preferably insulated, outside the building) to the circuit. Connect the receiver in series with the diode (rectifier) to the input of the amplifier, and connect a loudspeaker to the amplifier output. Grounding the circuit will probably help. Vary the capacitor setting to tune the circuit to the frequency of a local transmitter. If you are near a powerful station and/or have a long enough antenna, you can dispense with the amplifier and use earphones.

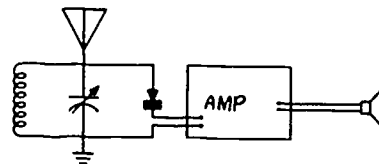

Fig. 13

You can use the oscilloscope to show the function of the diode. Connect the oscilloscope directly across the capacitor (no diode) to see the radio frequency

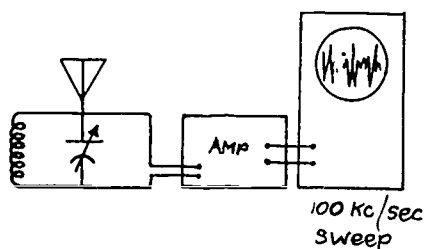

Fig. 14

carrier wave. Now add the diode in series and reduce the sweep rate to see the audio frequency signal:

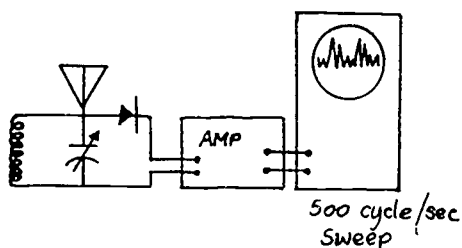

Fig. 15

For a very effective demonstration let students "see" the signal in this way while they are listening to it on a loudspeaker.

The diode in this circuit performs just the same function as the diode in the microwave probe. You can bring out this point by substituting the microwave diode in the LC circuit for the one provided. (But note that you cannot do the reverse—the diode from the LC circuit will not rectify at microwave frequencies.)

We have seen that the "transmitting" LC circuit can broadcast noise that is picked up on a transistor radio, and that the "receiving circuit" can pick up local radio broadcasts. As a final step we ought to be able to transmit a "signal" from one of our circuits to the other. The setup below should do it:



Fig. 16

The two coils must be quite close to each other. Vary the frequency setting of the audio oscillation (in the 300-5,000 cps range) and listen to the tone change in the loudspeaker. Investigate the effects of separating the two coils, placing a metal sheet between them, etc.

Evidently our "transmitter" is a pretty weak one, for the receiver must be very close to it to pick up the "broadcast." In fact this is really a demonstration of induction rather than radiation.

Instead of using the audio oscillator to provide the signal, try a microphone and amplifier:

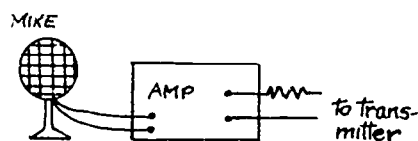

Fig. 17

(For this demonstration reduce the value of  $r_1$  or remove the resistor altogether.)

### C. MICROWAVES\*

With a microwave oscillator and detector one can demonstrate all the properties of electromagnetic radiation, often more easily than with light because of the longer wavelength of the microwaves. Demonstration D52 on p. 51 covers reflection, transmission, refraction, standing waves, diffraction, interference and polarization.

### Modulation and communication with microwaves

The older (pre-1968) microwave units use line frequency ac to supply the plate voltage. This means that the microwave signal is modulated at 60 cycles per second. This can be shown by connecting the diode detector to an oscilloscope or by connecting the detector to an amplifier and the amplifier output to a loudspeaker. The oscilloscope will show a half-wave 60-cycle signal, the loudspeaker will oscillate at 60 cps:

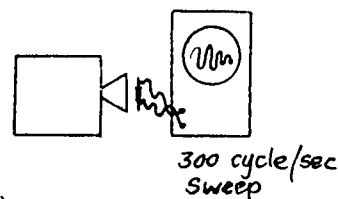

Fig. 18(a)

\*See equipment note on p. 81.

Experiments  
E38\*

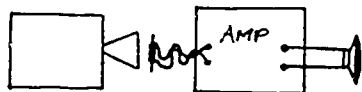

Fig. 18(b)

Be sure that students realize that this 60-cycle signal is the modulation frequency, not the carrier frequency. Show some beat patterns produced by the turntable oscillators to remind them of the difference between carrier and signal frequency. For microwaves the carrier frequency is

$$f = \frac{c}{\lambda} = \frac{3 \times 10^{10}}{3 \times 10^{-2}} = 10^{10} \text{ cps}$$

This frequency is unfortunately much too high to be displayed on a CRO.

On the newer microwave units the modulation frequency can be varied. (See equipment note p. 81.)

With the setup shown in Fig. 19 students can see the rectified, modulated signal on the oscilloscope, and hear it on the loudspeaker as the setting of the oscillators is varied in the audible range.

It is also possible to replace the oscillator with a microphone (or even a 45-ohm speaker) and use the amplified signal from the microphone to modulate the microwaves. This demonstration of radic is most effective if you use the setup shown below that avoids leads from the detector back to the source.

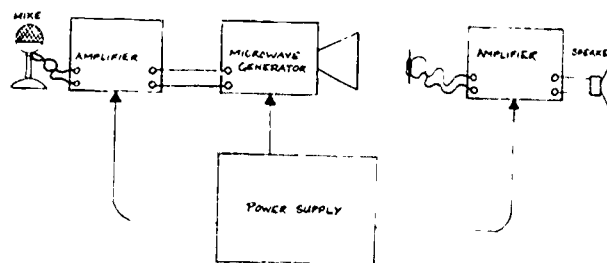

Fig. 20

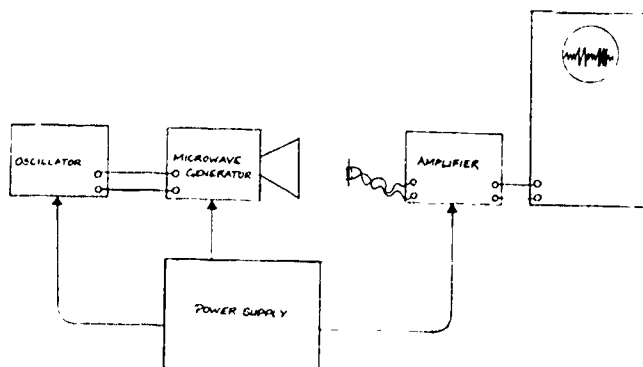

Fig. 19



### Current Balance

#### Parts list

Each current balance package should contain:

- 1 vertical pegboard with fixed coils
- 1 balance beam with short vertical rod and long horizontal pointer
- 4 (magnesium) loops (approx. 30, 16, 8, 4 cm)
- 1 "counterweight cylinder"
- 2 sensitivity clips
- 1 zero-mark indicator
- #30 copper wire
- 1 iron yoke
- 4 ceramic magnets

#### Accessories

- Ring stand and clamp
- Pressure-sensitive centimeter tape

#### Assembly

Assembly of the current balance should be clear from the instructions that accompany it.

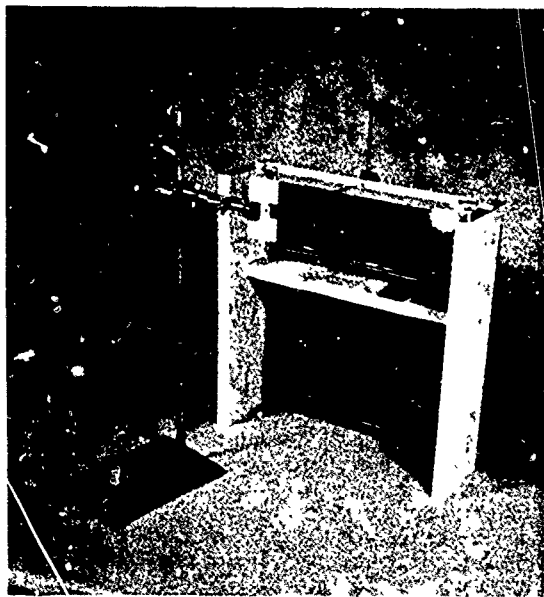

#### Design

This current balance measures the force between two straight, parallel, horizontal currents, or between one horizontal current and a vertical magnetic field.

One of the conductors is a fixed rectangular coil mounted on a pegboard frame and set vertically. In fact there are two fixed coils on this frame. One consists of a single blue wire, the other is a ten-turn coil of copper magnet wire. For most demonstrations the ten-turn coil is used, effectively increasing the current in the fixed coil by a factor of ten. The current in the fixed coil will be referred to as  $I_f$ .

A balance rests on the frame and consists of a pointer (with notch), counterweight cylinder, sensitivity adjustment clip, and four interchangeable  shaped magnesium wires. These will be referred to as loops. The current to the balance loop ( $I_b$ ) passes through the knife edges. The knife edges and the plates on which they rest are silver-plated.

The loops are very light, being made of a magnesium alloy. Students may remember some exciting experiments with magnesium foil or powder from their chemistry classes, and although the loops are actually quite difficult to ignite, the students' notes make no mention of magnesium. This alloy is quite brittle: once bent, it is almost impossible to change or adjust the bend without breaking it.

A horizontal force on the balance loop makes it swing out of the vertical. A vertical force has no result except to increase or decrease the effective weight of the loop.

The horizontal part of the balance loop is parallel to the top edge of the fixed wires and must lie in the same horizontal plane. With current in both loops, the thrust on the balance loop is then horizontal. If it is a repulsion force, it can be balanced by hanging weights over the notch on the pointer. (If the balance swings the wrong way, i.e., if there is an attractive force, one must reverse the direction of one of the currents, of course.) This null method is used for all measurements (as in E34, Electric Forces II—Coulomb's Law).

The fact that the loop responds to horizontal forces only is important in the design and operation of the current balance. The magnetic field due to the current in a straight wire varies inversely with distance from the wire ( $B = \frac{1}{a}$ , not  $\frac{1}{a^2}$ ). The field at the loop due to the current in the bottom wire(s) of the fixed coil is therefore not negligibly small. But because the loop is almost directly above the bottom wires, the force between them will also be in a

## Equipment Notes Current Balance

nearly vertical direction. The horizontal component of this force, which is all the loop responds to, is therefore small. If the top wire is 3 cm and the bottom wire 30 cm away from the loop, the total force due to the current in the bottom wire ( $F_B$ ) will be 1/10 the force due to the current in the top wire ( $F_T$ ). But the horizontal component of  $F_B$  will be about

$$\frac{1}{100} F_T$$

### The weights

As in the Coulomb's law experiment, students make their own set of weights by cutting lengths of wire. Number 30 copper cut into lengths of 1 cm, 2 cm, 5 cm and 10 cm will give a suitable range. Students will need several of each length.

### The sensitivity

Move the clip up the vertical rod to increase sensitivity. This raises the center of gravity. You will probably need to add a second clip to get maximum sensitivity (for instance to demonstrate and measure the effect of the earth's field on the current). But if the center of gravity is too high the balance is unstable and flops to either side. When the loops are changed, the center of mass of the balance system is moved, and it will be necessary to adjust the sensitivity clip.

Proper adjustment results in a slow oscillation (period of 3 to 5 seconds) about the zero, or balance, position. When set in this way, the balance should respond measurably to a "weight" of 0.5 cm of #30 copper wire at the notch in the pointer arm.

### Zero adjustment

Use the counterweight cylinder on the short horizontal arm to set the loop vertical, the pointer arm horizontal.

The zero position of the pointer is important, since the null method requires that the balance be returned to this same zero. A small indicator is provided. It

has a notch. You may have to add the index mark (as shown in sketch). The indicator should be clamped to a ring stand (use of a test-tube clamp makes it possible to slide the indicator easily for close final adjustments). The pointer on the balance should be inside the notch of the indicator to prevent wide oscillations in the balance.

### Measurement of distance between conductors

In some of the experiments it is necessary to measure the distance between the loop and the fixed coil. The student notes explain how to eliminate parallax when making this measurement by using a mirror and scale (centimeter tape stuck onto mirror surface).

### Effect of the earth's magnetic field

The balance responds to horizontal forces on the loop. Since the earth's magnetic field generally has a vertical component, it will exert a measurable horizontal force on the balance when there is a current in the loop. This force cannot be eliminated by reorienting the system.

The force due to the earth's field is small, but it is possible for students to measure it (Group C of Experiment 36). In fact, the value obtained for the vertical component of earth's field can be used in a later lecture-experiment for a  $q_e/m$  determination.

As long as the current in the balance loop remains constant, the effect on it of the earth's magnetic field will be constant and can be easily compensated. The simplest technique is just to set the zero mark to the position of the pointer when there is current in the balance loop, but none in the fixed coil. Of course, if the current in the balance loop is changed, or if the balance is moved, the zero mark must be reset. This is what students are instructed to do in Experiments 35 and 36.\*

\*There are at least two other possible ways to compensate:

- a) A small ceramic magnet can be moved near the balance loop. If located carefully (footnote continued on next page.)

Orientation of the current balance unim-  
portant

For any orientation (N-S, E-W) of the balance, the vertical component of the earth's field will give rise to a horizontal force (perpendicular to the direction of the current).

The horizontal component of the earth's field will interact with the vertical currents in the sides of the loop and give rise to horizontal forces. But since the currents are oppositely directed (up and down) the forces will be oppositely directed too. In particular if the balance is set up along an E-W line these forces will be "in" or "out":

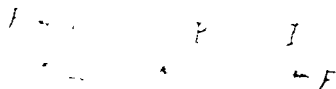

If the balance is set up along a N-S line the two forces will form a torque tending to twist the loop, but there will still be no net horizontal force.

---

(footnote continued)

fully, the force due to its field will just neutralize that due to the earth's. Once located, this compensating magnet must not be moved. And any changes in  $I_b$  will require a readjustment of the compensating magnet, of course. Imbalance between the earth's and the ceramic magnet's fields can be quickly noted. Flick  $I_b$  on and off a few times fairly rapidly (about 5 seconds apart for a balance whose period of oscillation is 5 seconds). If oscillation builds up in the pointer, readjust the position of the ceramic magnet.

b) Alongside the fixed wires of the current balance is one single wire—blue. A "countercurrent" in this wire can be made to balance the earth's effect on  $I_b$ . To set this current requires a power supply, ammeter, and either a rheostat or a variac. The blue wire is connected, and the direction of the required current found. Adjust this countercurrent until the pointer is pulled back to its zero position. In a prototype balance, with  $I_b = 2.0$  amps, it was found that a countercurrent of 5.5 amps was needed when the two loops were 1.0 cm apart. Any changes in  $I_b$ , or distance between the blue wire and the loop, will require a change in the countercurrent, of course.

**Equipment Notes**  
**Microwave Apparatus**

**Microwave Apparatus**

The microwave equipment utilizes a reflex klystron which when operated in its proper modes will generate electromagnetic radiation in the microwave band of frequencies. The kit includes a tube and integral cavity, an antenna horn, a microwave diode, reflectors, polarizing screen and double slit adapter.

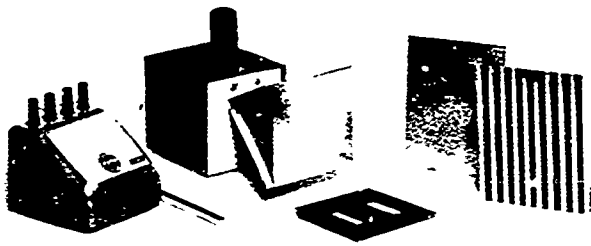

Microwave Kit

Fig. 1

The oscillator tube is a type 6110 electrically tunable reflex klystron. The tube is mounted on its tuned waveguide and has a horn for better radiation. The unit is designed to operate from the DAVON "Mark VII" power supply and derives all of its necessary power from this unit. Several microwave oscillators can be operated from the power supply simultaneously.



Fig. 2

The detector is a silicon diode the leads of which have been cut to form a 1/2 wave antenna. The diode is supplied mounted at the end of a phenolic tube in order to form a convenient probe.

Fig. 3

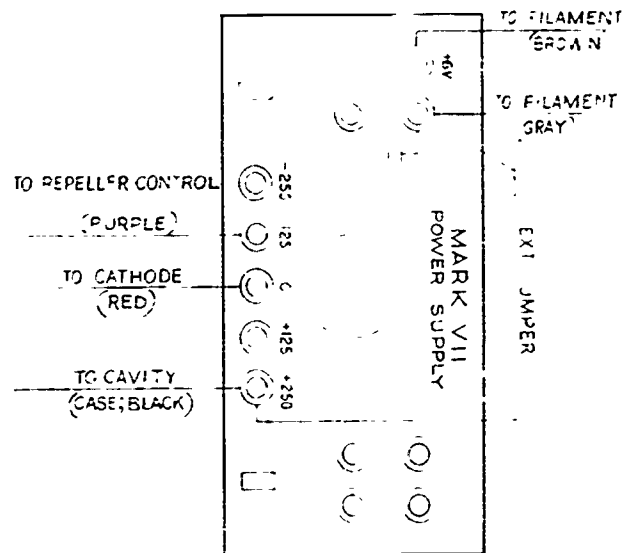

To operate the microwave oscillator, make the connections to the power supply as shown in Figure 3. Turn the power supply on and wait a few minutes for the tube to warm up. Use the diode and a 100  $\mu$ A meter as a detector, as shown in Figure 4. Hold the diode vertical in front of the horn and while in this position adjust the repeller voltage control to obtain a maximum meter deflection:

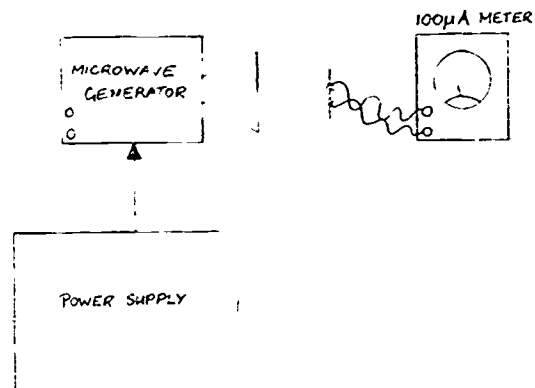

Fig. 4

if the meter goes off scale, move the diode farther away from the horn.

The microwave is polarized with the electric vector vertical (parallel to the short edge of the cavity). The cavity has been tuned by the manufacturer. The detector must be correctly oriented with the antenna leads parallel to the electric vector, i.e., vertical. The signal decrease in strength as the antenna is rotated. With the antenna horizontal, the signal strength is almost zero.

#### Modulation of Microwave Oscillation

On older (pre-1968) models, the microwave oscillation is modulated at line frequency (60 cps). On the new models, the 60-cycle internal modulation has been minimized, resulting in a relatively pure carrier wave. The microwave radiation may, therefore, remain unmodulated or be externally modulated at any chosen frequency. A modulation input (MOD INPUT) terminal has been provided on the microwave unit for this purpose.

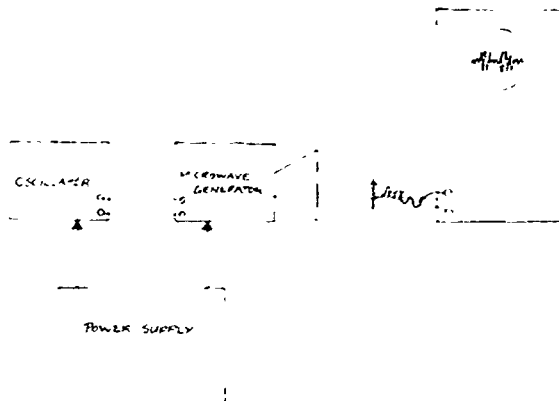

To modulate the microwave radiation, apply an audio-frequency signal to the MOD INPUT jack. This signal should have about 1 volt peak-to-peak voltage: the output of a Project Physics oscillator-unit is ideal. If higher gain is required, use the amplifier with the oscilloscope as shown in Figure 19 on p.78. The detector may be connected directly to an oscilloscope so that students can see the demodulated signal.

Alternatively, use an amplifier and loudspeaker as described below.

#### Readout Devices

If the microwave radiation is unmodulated, you must use a dc meter (or dc oscilloscope) as readout device; if it is modulated, any of the following can be used.

a) Meter - A 100  $\mu$ A meter is sensitive enough if the detector is not too far from the source. It can be used for both modulated and unmodulated radiation and one can make quantitative measurements.

b) Oscilloscope. (Unless you have a dc scope, you can use this for modulated radiation only.) Connect the detector between the vertical input of the oscilloscope and ground. Set the horizontal sweep to 5 to 10 times the modulation frequency. The rectified envelope of the modulated microwave envelope is clearly visible on the screen. Quantitative or semi-quantitative measurements may be made from the screen, depending on the sensitivity and calibration of the oscilloscope.

c) Amplifier and Loudspeaker. (Can be used with microwave radiation that is modulated in the audio range only.) The position of the nodes in a microwave interference pattern can be measured by listening for the nulls as you probe the field. For this experiment refer to page 78 and replace scope with a loudspeaker.

#### Troubleshooting the microwave equipment

- 1) Check all connections; refer to Figure 3.
- 2) Check that tube is warm.
- 3) Using microammeter and a reduced spacing (e.g., 10 cm) between horn and detector, adjust repeller voltage to maximize the detected signal (if any).
- 4) Try another diode detector, if one is available.

PHYSICS

*The Electromagnetic Spectrum*

ALBERT F. EISS, Associate Executive Secretary, National Science Teachers Association, Washington, D. C.

An understanding of the electromagnetic spectrum is becoming increasingly important in science. In addition to the physical concepts related to frequency and wavelength of such waves, the waves are particularly important in the general fields of communication and are frequently discussed in science classes. Probably everyone knows of their use in radio, television, and optics. Not as well known, however, is the fact that we obtain almost all our information about the sun and our universe from such waves, similarly at the other dimension, we obtain from them much of our knowledge of bacteria and even of the atom itself.

Such communication is not without its problems. Thus, it is frequently said that the radio bands are overcrowded, and everyone has sometimes heard two stations at one radio setting. He may have wondered why these couldn't have been kept apart. A student may even have heard it said that if only we could use the wavelengths in the visible spectrum, we wouldn't have this trouble. In fact, a student may have read that lasers, which operate in the visible light spectrum, offer some hope for extension of communication in the future. At laser frequencies there are many possibilities which are as yet unexplored. For example, NASA is considering using a CO<sub>2</sub> laser

transmitter on a Mars probe. With an output of 500 watts, such a laser transmitter is powerful enough to send messages from Mars to Earth. There is far wider frequency range available with lasers than there is with present communication bands.

A little study of the electromagnetic spectrum may help the student evaluate these statements as well as show him something about the use of exponentials. Possible frequency ranges are not apparent from a cursory look at the usual diagram of the electromagnetic spectrum. In fact, the complete diagram of the electromagnetic spectrum is not generally shown in science books. In case you may have trouble finding such a diagram, an example is shown below.

In this diagram, the width of the visible spectrum does not appear to be as large as that of the radio communication bands. A simple way of giving students a better idea of the true state of affairs would be to provide them with the data on the electromagnetic spectrum which appear in the table below.

Students should be reminded that electromagnetic waves, even at audio frequencies, cannot be heard, because the ear does not detect such waves. However, if audio-frequency electromagnetic waves were used to generate sound waves at the same frequency, they could then be heard.

The data contained in the table will produce a diagram which will compare closely with that shown in the illustration.

<sup>1</sup> *Electronic News*, September 19, 1966, p. 5.  
<sup>2</sup> Miller, Stewart I., "Communication by Laser," *Scientific American*, 214, 19, 27, January, 1966.  
Illustration reproduced from Verwiebe, Frank I., Van Hooft, Gordon F., and Suchs, Robert P., *Physics: A Basic Science*, Copyright 1962, D. Van Nostrand Company, Inc., Princeton, New Jersey.

Frequency of Electromagnetic Radiations\* (in cycles per second)

Secondary Cosmic Rays	10 <sup>1</sup> to 10 <sup>24</sup>
Gamma Rays	10 <sup>17</sup> to 10 <sup>24</sup>
X Rays	10 <sup>16</sup> to 10 <sup>18</sup>
Ultraviolet	10 <sup>15</sup> to 10 <sup>16</sup>
Visible Light	10 <sup>14</sup> to 10 <sup>15</sup>
(more precisely 3.9 x 10 <sup>14</sup> to 7.7 x 10 <sup>14</sup> )	
Infrared	10 <sup>12</sup> to 10 <sup>14</sup>
Radio Frequencies	10 <sup>3</sup> to 10 <sup>11</sup>
Audio Frequencies	10 to 10 <sup>4</sup>
(more precisely 1.6 x 10 to 2 x 10 <sup>4</sup> )	

\*These values are approximate and here are given only as a guide to the order of magnitude.

transmission, if graphed on a logarithmic scale. Students will have no difficulty in making such a graph, using 1 cm width to represent each power of ten. You may point out to them that each space on a logarithmic scale represents ten times the distance represented by the preceding space below, and one-tenth of the space above.

Many students fail to realize what this statement really means. Ask the average student to subtract 10<sup>11</sup> from 10<sup>12</sup>. The chances are that his reply will be 10<sup>1</sup> which, of course, is incorrect. The correct answer is 9 · 10<sup>11</sup>. The student who answers 10<sup>1</sup> has subtracted exponents, or divided instead of subtracting. One way of explaining this is to set the problem down on paper. If you wish to subtract two numbers expressed as powers of ten, you must first change both numbers to the same power of 10 or write out the full number. Thus, 10<sup>12</sup> must be expressed as 10 · 10<sup>11</sup>. Now the problem is simple, 10 · 10<sup>11</sup> - 1 · 10<sup>11</sup> = 9 · 10<sup>11</sup>.

At first some discussion of the "width" of the visible band, ask the students to prepare a linear graph of the data in the table. Suggest that the students use 1 cm to represent 10<sup>14</sup> cycles/sec.

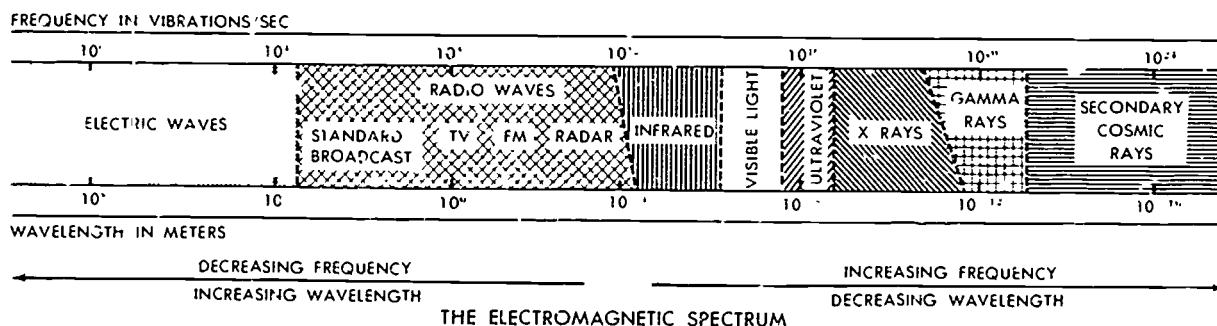



## Articles

### Electromagnetic Spectrum

(or vibrations sec), which is approximately 10 percent of the width of the audio and radio bands combined. How high would the graph be to represent the audio spectrum? the radio spectrum? How high would the graph be if you were to include all frequencies up to the lower edge of the visible spectrum,  $10^{12}$  cycles sec? If you were to include the visible spectrum? the entire spectrum? Why is a linear graph not too useful for this purpose?

Most students will be surprised to find that the top of the radio frequencies ( $10^7$ ) will *not* be the next line on the graph, but will be 9 cm above the first line, which represents  $10^3$ . They will probably be still more surprised to find that the graph of frequencies reaching to the edge of the visible spectrum ( $10^{12}$ ) will require a distance slightly more than the length of a football field, and the entire spectrum would require approximately  $6.2 \times 10^7$  miles, which is more than  $6\frac{1}{2}$  times the distance from the earth to the sun. A look at the wavelengths represented will convince them that there is no error in their computations, since they will be equally unable to design a useful linear scale for graphing wavelengths.

The students can then see why the visible light region, if it could be tapped, would be very useful. Moreover, for radio communications, it is not only the frequency that is important but also the frequency band or range of frequencies used. Thus, the width of a radio broadcast band is  $10^4$  cycles sec (or 10 kc sec). That is, if you are tuning a station at 600 kc on your AM radio, you will be actively using all the frequencies between 595 and 605 kc sec. The lowest frequency above 600 kc which another station could use would be 610 kc, and even this would produce some interference if it were a strong station nearby.

Thus, a portion of the radio spectrum from 1650 to 550 kc, approximately what is commonly designated as the AM broadcast band is a bandwidth of 1100 kc. In this range there are 1100 kc/10 kc, or only 110 separate allocations available for radio

stations. Therefore, several stations must be assigned the same frequency.

But what if we were to use FM on these channels? An FM station requires a bandwidth of 200 kc. The 1650 to 550 kc portion of the spectrum would only permit five FM stations, with 100 kc left over. How about TV? A TV station requires a bandwidth of five megacycles, or five million cycles! One could not accommodate a TV station on the AM broadcast band at all!

From here there are several interesting avenues for exploration. The 10 kc bandwidth assigned to commercial AM stations explains why they are limited to an audio range of 5000 cycles sec and why they cannot broadcast with high fidelity on the AM band. Students can be asked how many stations of a given bandwidth (AM, FM, or TV) could be assigned to a given portion of the electromagnetic spectrum.

Another interesting problem in assigning radio frequency bands for communication did not arise until ultra high frequency and microwave channels came into demand for commercial use. Many channels in these ranges are now in use. For example, UHF radio uses channels from 470 to 890 megacycles. Telephone and TV communications networks are now operating in the 2000-6000 megacycle range. However, at the present time commercial users are not permitted to use frequencies around 1400 megacycles, although there has been some suggestion that frequencies in this range be opened for use. This is being strongly opposed by astronomers because of the fact that cold neutral hydrogen atoms emit a spectral line at 21 centimeters, or 1420.4 megacycles. This was predicted theoretically as early as 1944, but it was not detected experimentally until 1951. Since then, a study of the intensity of the hydrogen emission has become an important aspect of radioastronomy because this frequency, unlike visible frequencies, is not blocked out by interstellar dust. Consequently, astronomers can use this frequency to determine the distribution of hydrogen atoms in our galaxy,

except at the center where the emission is blocked out by other radiations.

A decision to resolve this conflict of interest must be made by the government. Should the necessary frequency band be held open for radioastronomers, eliminating useful commercial channels, or should the channels be used for practical purposes, thus blocking some fundamental research into the nature of the universe? At present, the FCC has protected the necessary frequencies for research use, but can this be justified? And is this any guarantee that economic or political pressures might not force a reconsideration of this decision? This would make an excellent topic for class discussion and further study.

It is probable that the students will have a much better appreciation of the meaning of exponents in scientific notation after completing these exercises, and they will have more understanding of the immense range of the electromagnetic spectrum. ==

Fields

Influence in space

The idea of the two-step process is fairly simple to get across and is reinforced in the next section. Perhaps the point can best be made on the blackboard:

Empty space.

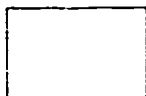

A body moving in empty space has a constant velocity.

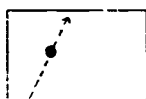

If another body is introduced, the path of the first one is modified.

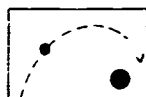

The modification can be thought of as resulting from a force which the one body exerts directly on the other,



or, the one body can be thought of as producing some kind of effect in the space around it,

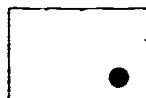

and that influence in space exerts a force that modifies the path of the first body.

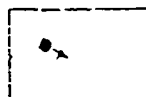

(There is also the general relativity view, in which it is the geometry of space which is modified, so that the body is actually still moving in a "straight line." It is not so much that the body causes a distortion of space as that it is a distortion of space.)

Test bodies

The expression "force per unit mass" is awkward. It should be made clear that the test body need not be one unit, any more than one must drive for a whole hour in order to go 60 miles per hour. It is the ratio of force to mass that characterizes the field. If there is more mass to be acted upon, the force will be greater.

The concept of a "test body" is used throughout the chapter. A test body must be small in two ways. It must be sufficiently small in mass (or charge, or whatever) that it does not appreciably

modify the main sources of the field, and so change the field it is trying to explore. It must also be small in size (compared to the scale on which the field is being considered) so that there is essentially one value to the field in the space it occupies. (A striking illustration of this requirement is the supposed fate of a moon that approaches too closely its planet—the gravitational field becomes sufficiently different on different parts of the moon so that the moon is torn apart.)

Does a field really exist?

The independent existence of a field, regardless of whether or not there is something for it to act upon, is as much a philosophical problem as a physical one. The descriptions of phenomena in terms of fields are consistent and useful. Energy can be considered to be stored in a field and so field disturbances are accompanied by transfer of energy. But the question of "does a field actually exist in empty space or is it just a way of thinking of things?" must be put on the shelf with a number of similar epistemological problems. Suffice it to say that almost all physicists think of fields as if they exist.

Relation of  $\vec{g}$  to  $\vec{a}_g$

We have tried, in some strain on the conventions of the profession, to use  $\vec{a}_g$  for the acceleration produced by gravity. Don't say that the gravitational field  $\vec{g}$  is the same as  $\vec{a}_g$ .

There is no need for the relation of the two to be pointed out, and if students don't bring it up it is probably best to let it slip by. The acceleration  $\vec{a}_g$  can be measured by distances and times. Using Newton's second law, we would say that the gravitational force on a body is  $\vec{F}_g = m_i \vec{a}_g$  where  $m_i$  is a measure of the body's inertia. By the definition of gravitational field strength  $\vec{g}$ ,  $\vec{F}_g = m_g \vec{g}$ , where  $m_g$  is a measure of the body's response to gravity. Because the "gravitational mass" of a body is proportional to the "inertial mass," the gravitational acceleration is proportional to the gravitational field strength (as found by experiment to within one part in  $10^{11}$ ). Because the same body (the "standard kilogram") is used for defining units of both quantities, and the units are both given the same name "kilogram,"  $\vec{a}_g$  is actually equal numerically and dimensionally to  $\vec{g}$ . (In general relativity the complete equivalence of inertial and gravitational mass



## Articles Fields

is assumed, so that  $\dot{a}_g$  and  $\dot{g}$  are identical—there is no distinction made between them—acceleration and gravitational force are different ways of viewing the same thing.) There is an important distinction between  $a_g$  and  $g$  in the context of an elementary course. A measured value of  $a_g$  will be equal to  $g$  only if a test body is allowed to fall freely. If a body is supported, it is still acted on by  $g$ , but its acceleration is zero. Although it is perfectly legitimate to consider a supported body to have an acceleration component  $a_g$ , (cancelled out by an acceleration component due to the supporting force) that viewpoint will be hard to sell to students.

### "Self-action" of a field

Some students may bring up the issue of the effect produced on a body by its own field. There are some very deep problems involved here (e.g., see Feynman's Nobel Prize address in Physics Today, September 1966). For the purposes of this course, it will be sufficient to appeal to the two-step representation: the effect of one body on another is represented as a field set up by the first, and that field acting on the second—and vice versa: the effect of the second body on the first is represented as a field set up by the second, and that field acting on the first. If a body does have an effect on itself, then it could be considered to be affected by its own field. In Newtonian mechanics there is no such self-effect (witness Newton's first law), so that a body is properly considered as acted upon only by the combined fields of all other bodies. (By body here we mean a minuscule particle. The body of the earth is affected by other parts of the body, so that in that sense it acts on itself.) The essence of this concept can be brought out by asking the students to rewrite

$$F = \frac{GMm}{r^2} \quad \text{in terms of the}$$

moon's gravitational field.

### Adding fields

If fields are defined in terms of forces and forces are defined in terms of accelerations, then in one sense fields must by definition add vectorially as accelerations do. What is at issue, however, is that the effect of one source is the same whether or not some other source is present and having an effect also. That is, that force fields defined in terms of their sources add as vectors. In the case of a field produced by several charged conductors, the presence of

one will affect the distribution of charge on the others, so that the field resulting from the presence of all is not the vector sum of the fields which would be produced by each source alone in the absence of the others. The disturbed fields of the disturbed sources do add vectorially, however. The business of mutual disturbance can be very complicated, so that often the configuration of sources required to produce a desired field pattern must be found by trial and error instead of direct calculation.

### Shielding limitations

Shielding from external fields is not strictly correct for extremes of field strength or extremes of rate of change of field strength. If an external field were so phenomenally strong as to cause all the loose charge on a conducting shell to move to locations so as to produce a net field of zero inside, then there would be no more shift possible and any increase in the external field could not be balanced. If the external field is changing at a rate of  $10^{10}$  cycles/sec, (that is, x rays), the charges in the conductor could not oscillate rapidly enough to cancel it out inside and the changing field could penetrate to the interior. For almost-closed conducting shells (as in electron-gun electrodes or cyclotron "Dees"), the field is almost zero deep inside. Incidentally, conducting shells do not shield the space around it from a static charge inside unless the shell is grounded.

### Grass seeds

It probably isn't worthwhile taking the time to explain why grass seeds line up in a field unless students explicitly raise the question. If you can get away with it, don't worry about the phenomenon of polarization of an insulator, as that involves atoms and charge clouds—which we have not yet officially met. The ends of the grass seed become charged oppositely, so that the field exerts opposite forces on the two ends. These forces will tend to turn the grass seed into a position along a line of force. Even when lined up, the force will be greater on the end where the field is stronger, so the grass seed will be pulled into a region of stronger field.

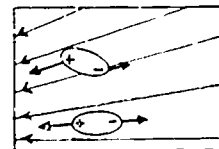

The charged ends of the grass seed attract one another, so that there is a tendency for trains of seeds to form.

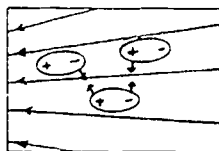

Where the lines of force are curved, the vector sum of the forces on the seed will tend to move it into less curved regions of field.

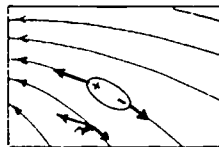

#### A sidelight

A sidelight not mentioned in the text is that the field lines in the static case are always perpendicular to the surface of a conducting material. At distances large compared to the dimensions of a charged body, the field will be indistinguishable from that of a spherically symmetrical charge distribution. This is directly related to the principle that the surface of a conductor is an equipotential surface, but that at distances large compared to the dimensions of an object the equipotential surfaces are spheres. These principles are of no great importance for the purposes of this course, but they are fun to draw.

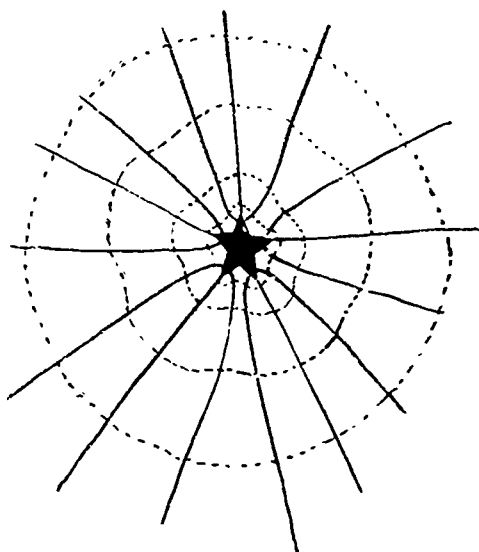

#### Oersted

Here is Oersted's own account of the history of his discovery, written in the third person as part of an article on "Thermoelectricity" for Brewster's Edinburgh Encyclopedia (1830):

"Electromagnetism itself was discovered in the year 1820, by Professor Hans Christian Oersted, of the university of Copenhagen. Throughout his literary career, he adhered to the opinion, that the magnetical effects are produced by the same powers as the electrical. He was not so much led to this, by the reasons commonly alleged for this opinion, as by the philosophical principle, that all phenomena are produced by the same original power. In a treatise upon the chemical law of nature, published in Germany in 1812, under the title Ansichten der chemischen Naturgesetze, and translated into French, under the title of Recherches sur l'identite des forces electriques et chimiques, 1813, he endeavoured to establish a general chemical theory, in harmony with this principle. In this work, he proved that not only chemical affinities, but also heat and light are produced by the same two powers, which probably might be only two different forms of one primordial power. He stated also, that the magnetical effects were produced by the same powers; but he was well aware, that nothing in the whole work was less satisfactory, than the reasons he alleged for this. His researches upon this subject were still fruitless, until the year 1820. In the winter of 1819-20, he delivered a course of lectures upon electricity, galvanism, and magnetism, before an audience that had been previously acquainted with the principles of natural philosophy. In composing the lecture, in which he was to treat of the analogy between magnetism and electricity, he conjectured, that if it were possible to produce any magnetical effect by electricity, this could not be in the direction of the current, since this had been so often tried in vain, but that it must be produced by a lateral action. This was strictly connected with his other ideas; for he did not consider the transmission of electricity through a conductor as an uniform stream, but as a succession of interruptions and re-establishments of equilibrium, in such a manner that the electrical powers in the current were not in quiet equilibrium, but in a state of continual conflict. As the luminous and heating effect of the electrical current goes out in all directions from a conductor, which transmits a great quantity of electricity; so he thought it possible that the magnetical effect could likewise radiate. The observa-

Articles  
Romer

tions above recorded, of magnetical effects produced by lightning, in steel-needles not immediately struck, confirmed him in his opinion. He was nevertheless far from expecting a great magnetical effect of the galvanical pile; and still he supposed that a power, sufficient to make the conducting wire glowing, might be required. The plan of the first experiment was, to make the current of a little galvanic trough apparatus, commonly used in his lectures, pass through a very thin platina wire, which was placed over a compass covered with glass. The preparations for the experiments were made, but some accident having hindered him from trying it before the lecture, he intended to defer it to another opportunity; yet during the lecture, the probability of its success appeared stronger, so that he made the first experiment in the presence of the audience. The magnetical needle, though included in a box, was disturbed; but as the effect was very feeble, and must, before its law was discovered, seem very irregular, the experiment made no strong impression on the audience. It may appear strange, that the discoverer made no further experiments upon the subject during three months; he himself finds it difficult enough to conceive it; but the extreme feebleness and seeming confusion of the phenomena in the first experiment, the remembrance of the numerous errors committed upon this subject by earlier philosophers, and particularly by his friend Ritter, the claim such a matter has to be treated with earnest attention, may have determined him to delay his researches to a more convenient time. In the month of July 1820, he again resumed the experiment, making use of a much more considerable galvanical apparatus. The success was now evident, yet the effects were still feeble in the first repetitions of the experiment, because he employed only very thin wires, supposing that the magnetical effect would not take place, when heat and light were not produced by the galvanical current; but he soon found that conductors of a greater diameter give much more effect; and he then discovered, by continued experiments during a few days, the fundamental law of electromagnetism, viz. that the magnetical effect of the electrical current has a circular motion round it."

Romer

In most textbooks you will find the statement that Römer was the first person to determine the speed of light. You will find various values attributed to him, and most of these values are different even when converted to the same system of units (the average is about 2/3 the present value). Anyone who actually takes the trouble to read Römer's original paper will find that all he did was to estimate the time it takes light to cross a certain fraction of the earth's orbit. He also says that light would take less than a second to cross the diameter of the earth; since he thought the earth's diameter was about 9000 miles (depending on how you interpret the units he used) this means that the speed of light is greater than 9000 miles per second. But for seventeenth-century scientists the real significance of Römer's work was not the actual value of the speed of light, but the fact that it is finite rather than infinite. This is analogous to the case of Boyle's work on air pressure: Boyle is known as the discoverer of "Boyle's law"  $PV = \text{constant}$ , but in fact he wasn't the first to find this relation by experiment. Instead, he did something even more important: he showed that air pressure is finite, and is responsible (rather than nature's horror of a vacuum) for holding up the mercury in a barometer, or the water in a suction pump. These two examples, Römer and Boyle, show how different (and how much more interesting) the history of science can become if we try to look at a scientist's work directly and in the context of its own times, rather than judging it, through the reports of textbooks, on the basis of how it solved problems that we now consider significant.

Although Römer did not apparently have data on the diameter of the planetary orbits from which he could compute the actual speed of light, such data was just becoming available at the time he worked. In 1672, the French astronomers Jean Richer and Jean Dominique Cassini determined the Earth-Mars distance by triangulation of Mars. They used a baseline with Paris at one end and Cayenne, on the northern coast of South America, at the other. Since, as we saw in Unit 2, the relative distances of all the planets from the sun, and relative Earth-Mars distance at a given time, could be found from the heliocentric theory, all these distances could be found as soon as one of them was known. The Richer-Cassini observations led to an Earth-Sun distance of 87 million miles. Huygens, in 1678, used this value together with Römer's data on the time-interval to compute the speed of light. Huygens' value,  $2 \times 10^8$  m/sec, was published in his treatise on light in 1690, together with an analysis of Römer's observations; later scientists seem to have

misread this passage and thought that Romer himself had gotten that value.

Another way of determining the velocity of light from astronomical observations was discovered by the British astronomer James Bradley in 1728. He found that certain stars change their positions in the sky during the year in a peculiar way. Although he was originally trying to observe the parallax of such stars, it turned out that this effect could not be attributed to parallax but was due instead to the component of motion of the earth at right angles to the line of sight from the star to earth. During the finite time that it takes for light from the star to go from one end of the telescope to the other, the telescope itself moves because of the motion of the earth, and so the telescope must be tilted slightly to see the star. This effect is known as stellar aberration, and its magnitude depends on the ratio of the orbital speed of the earth to the speed of light, as well as on the position of the star relative to the plane of the ecliptic. Since the orbital speed is known, the speed of light can be calculated. The value obtained was within a few per cent of the present value.

Bradley's discovery of stellar aberration was historically important for another reason: it was, in a sense, the first direct astronomical evidence for the heliocentric theory! Yet by the time it was found, most scientists had already accepted the heliocentric theory for other reasons (see Unit 2). Here is an interesting example of the relative unimportance of experiments and observations, as compared to convincing theories, in changing a worldview.

The subsequent history of determinations of the speed of light is reported in J.H. Rush, "The Speed of Light," Scientific American, August 1955, p. 67 and books in the bibliography.

In Chapter 16, we note that Hertz's experimental determination that electromagnetic waves have the same speed as light was one piece of evidence for the hypothesis that light waves are a form of electromagnetic waves. In Chapter 20 we again encounter the speed of light as a maximum speed in relativity theory

the electrical and mechanical connections. The circuitry is done on a metal ground plane that serves the normal chassis functions of mechanical support and common ground. Each block has the standard schematic symbol for the component on the top. From the wide selection of component blocks available, complete electronic circuits, from the most simple to complex, fully-operating transistor radios, can be assembled.

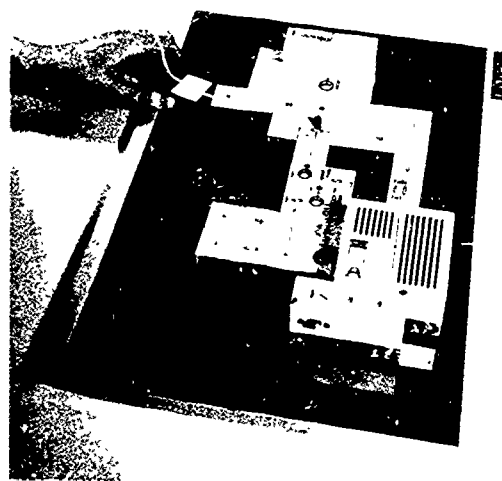

Lectron is a complete, self-contained survey course in circuitry which introduces students to theory as well as the practical applications of components and circuitry. Because of its basic simplicity, very little background preparation is needed; however, it is also challenging to more sophisticated students. It is ideal for any level science, industrial arts or vocational program.

By reducing a functional circuit to a series of "building blocks," students see the role each component plays in the circuit design. A finished circuit is an exact duplication of its schematic diagram and can be checked easily at any point in the experiment. A small 9V battery is the only source of power required, even for the largest circuits.

No tools are needed. No safety precautions are required. Set-up time is reduced to a bare minimum. Inventory can be done quickly and easily because all components are clearly identified.

Detailed information can be obtained from Raytheon Education Co., D.C. Heath Building, Boston, Mass.

#### "Lectron" Series

Lectron is a simple, magnetic-connecting building-block system replacing separate component parts. Each self-contained block is the component. Magnetic contacts on the sides and bottom of each block are

This article was adapted from a Raytheon Education brochure. While there was no direct involvement with this particular item and Project Physics, we feel it is uniquely applicable to lab work in electricity and electronics.

## Bibliography for Unit 4

## KEY:

- (T) Recommended for teacher background  
 (S) Student supplementary material  
 (T,S) Teacher should read first  
 (S,T) Student can read, teacher would find useful

- (T) Andrews, C. L., Optics of the Electromagnetic Spectrum, Prentice-Hall, Englewood Cliffs, NJ \$9.75 (1960)
- (T,S) Asher, Harry Experiments in Seeing, Basic Books, NY \$4.95 (1961)
- (T,S) Asimov, Isaac Understanding Physics, Volume II, Light, Magnetism, and Electricity Walker and Company, NY \$6.50
- (T) Barr, E. S. "Men and Milestones in Optics. II. Thomas Young" Applied Optics 2, 639ff (1963), reprinted in The Physics Teacher 5, 53 (1967)
- (T,S) Bergmans, J. Seeing Colours, translated by T. Holmes, MacMillan, NY 80 pp. (1960) An introduction, with minimal mathematics, to the production, measurement, and specification of color with emphasis on color rendition under fluorescent lamps. (Some of the terms are not those recommended by the International Commission on Illumination.)
- (T,S) Birren, Faber The Story of Color: From Ancient Mystics to Modern Science Crown Press, Westport, Conn. 338 pp. (1941)  
 A mine of fascinating information best described by the subtitle, and if some of the significances that have been attached to colors seem ridiculous, perhaps we may blame our own sophistication arising from our modern scientific environment and training. Tremendous and far-ranging bibliography.
- (T,S) Bitter, Francis Magnets: The Education of a Physicist (Science Study Series) Garden City, Doubleday Paperback \$1.25 (1959)  
 The autobiography of Francis Bitter and an account of his studies of the theories of magnetism.
- (T,S) Bouma, P. J. Physical Aspects of Colour, Elsevier, NY 312 pp. (1948)  
 The somewhat clumsy English idiom and the occasional use of mathematics in this last work of a leading investigator (posthumously translated and printed in Holland) is overbalanced by its charmingly casual style. Extensively documented.
- (T,S) Bragg, W. The Universe of Light, G. Bell, London (1931) reprinted by Dover, NY 283 pp. (1959)  
 Popular lectures on the more describable phenomena of light and x rays at about the high-school level. No bibliography.
- (T,S) Buban, Peter  
 Schmitt, M.L. Understanding Electricity and Electronics, McGraw-Hill, NY \$8.50 Text Edition \$6.48 (1962)  
 An elementary book on practical electronics.
- (T,S) Candler, A. C. Modern Interferometers, Hilger and Watts, London 502 pp. (1951)  
 An eminently clear and practical book, some of which can be enjoyed by those having only an elementary knowledge of optics. Extensive bibliography.
- (T) Cohen, I. B. "The First Explanation of Interference," American Journal of Physics 8, 99-106 (1940)
- (T,S) Conn, G. K. T. The Wave Nature of the Electron, Blackie, London 78 pp. (1938)  
 The phenomena which indicate that radiant energy is emitted and absorbed as particles but is transmitted as waves are described in layman's language with only a trace of mathematics List of books.



## Bibliography

- (T,S) DeCamp, I. Sprague The Heroic Age of American Invention, Doubleday, Garden City, NY (1961)
- (T) Dévé, C. C. Optical Workshop Principles, translated by T. L. Tippell, Hilger and Watts, London xxiv + 436 pp. (1954) (1949)  
The classic of advanced methods, with a certain amount of theory. Although primarily for the further education of present workers, the book is interesting as pure reading for optical buffs. No bibliography but bilingual glossary of workshop terms.
- (T,S) Dibner, Bern The Atlantic Cable, Blaisdell
- (T) Dibner, Bern Alessandro Volta and the Electric Battery, Watts \$2.95
- (T) Dibner, Bern Oersted and the Discovery of Electromagnetism, Dover Publications, NY \$1.00
- (T,S) Dogigli, J. The Magic of Rays, translated by C. Fullman, Knopf, NY 275 pp. (1961) (1957)  
An entertaining, episodic description of the nature and effects of radiation from x rays through the visible spectrum to short radio waves with interesting anecdotes about the persons involved. No bibliography.
- (T,S) Doland, E. F., Jr. The Camera, Messner, NY 191 pp. (1965)  
The history of black-and-white photography from the earliest times entertainingly and rather accurately told with anecdotes to add vividness and to show the importance of photography in our present civilization. (Although the anecdotes about the pioneers are contrived, they are based on fact and impart a sense of immediacy.) Bibliography.
- (T,S) Duhem, Pierre The Aim and Structure of Physical Theory, translated from French, Princeton Univ. Press (1954)  
A positivist view of the philosophy of science, illustrated by several historical examples from electromagnetic theory. The comparison of French and British styles in theoretical physics in Chapter IV is especially interesting.
- (T,S) Epstein, P. S. "Centennial of the Undulatory Theory of Light" Science 63, 387-393 (1926)
- (T,S) Evans, R. M. An Introduction to Color, Wiley, NY \$15 (1948)  
A very complete discussion of both physical and physiological aspects of light (color).
- (T) Feynman, Richard P. Leighton, Robert B. Sands, Matthew The Feynman Lectures on Physics, Addison-Wesley, Reading, Mass. (1963, 1964)  
Volume 1 includes chapters on optics, color vision, waves and radiation; Volume 2, electricity and magnetism. Though too difficult for general use as a college text, this book has been widely praised by physicists as a stimulating exposition of elementary physics from an advanced standpoint.
- (T,S) Fink, D. G. Lutyens, D. M. The Physics of Television (Science Study Series) Garden City, Doubleday Paperback \$1.25 (1960)  
An easily understood explanation of television systems and how they work. It briefly discusses color, color television and light.
- (T) Gilbert, William De Magnete (English translation) Dover Publications, NY \$2.50 (1958)
- (T) Gillispie, Charles Coulston The Edge of Objectivity: An Essay in the History of Scientific Ideas, Princeton Univ. Press Paperback \$2.95 (1960)  
Chapter X, "Field Physics"
- (T,S) Gramet, Charles Light and Sight, Abelard Schuman, London and New York 160 pp. (1963)  
A description in simple but uncondescending terms (by a high-school science teacher) of the eyes of lower animals and man, color, the microscope and telescope, x rays, television, even the laser and more. (Dads will also enjoy it.) Excellent sketches; no bibliography.

## Bibliography

- (T) Halbertsma, K. T. A. A History of the Theory of Colour, Swets & Zeitlinger, Amsterdam (1949)
- (T) Hesse, Mary B. "Action at a Distance in Classical Physics" Isis 46, 337-353 (1955)
- (T) Hesse, Mary B. Forces and Fields: A Study of Action at a Distance in the History of Physics, Nelson, London Paperback reprint by Littlefield, Adams \$2.25 (1961)
- (T,S) Hoffman, Banesh The Strange Story of the Quantum, Dover, NY 2nd ed. 285 pp. (1959) (1947 ed. with postscript)  
The history of the quantum theory of matter and energy, told entertainingly and without mathematics. No bibliography.
- (T) Houstoun, R. A. Light and Colour, Longmans, Green, London 179 pp. (1923)  
Although seriously dated (especially with respect to quantum theory, atomic structure, color photography and color vision) and sadly lacking in bibliography, this is still a sound and readable book on historical principles for anyone with the background of a bright high-school senior or better.
- (S,T) Jaffe, Bernard Michelson and the Speed of Light (Science Study Series) Doubleday Anchor, Garden City 95¢ (1960)
- (T) Jessop, H. T.  
Harris, F. C. Photoelasticity: Principles and Methods, Dover, NY 184 pp. (1960) (1949)  
A grassroots treatment with a minimum (but not an absence) of mathematics from which the principles can be intuitively grasped. No bibliography.
- (T,S) Josephson, M. Edison: A Biography, Eyre & Spottiswoode, London (1961)
- (T,S) Judd, D. B.  
Wyszecki, Günter Color in Business, Science and Industry, Wiley, NY 2nd ed., 500 pp. (1963)  
A readable treatise on color perception, production, and measurement, with a wealth of concrete examples; the theory and mathematics of color applied to daily life. Extensive bibliography.
- (T,S) Klein, H. S. Masers and Lasers, Lippincott, Philadelphia \$3.95 (1963)  
Interesting, easily understood discussions on coherent micro-wave and light sources.
- (S) Kohn, Bernice Light, Coward-McCann, NY 41 pp., largely pictures (1965)  
A book that your father can read to your 6- to 8-year-old brother or sister; as accurate, within its limitations, as the more erudite ones in this list.
- (T,S) Kohn, Bernice Light You Cannot See, Prentice-Hall, Englewood Cliffs, NJ 72 pp. (1965)  
Youngsters 9-12 years old will enjoy Mrs. Kohn's generally accurate descriptions of the nature and uses of the various sections of the electromagnetic spectrum.
- (T,S) Koller, L. R. Ultraviolet Radiation, Wiley, NY 270 pp. (1952)  
A straightforward account of natural and artificial sources, the behavior of materials to ultraviolet light, and methods of measurement. Bibliography.
- (T) Kranzberg, Melvin  
Pursell, Carroll W., Jr. Technology in Western Civilization, Volume I, The Emergence of Modern Industrial Society, Earliest Times to 1900, Oxford Univ. Press, NY (1967)  
See in particular the following articles:  
"The Beginning of Electricity" by Bern Dibner, pp. 437-452.  
"Communications" by Bern Dibner, pp. 452-468.  
"Applications of Electricity" by Harold I. Sharlin, pp. 563-578.  
"Electrical Generation and Transmission" by Harold I. Sharlin, pp. 578-592.  
"Technology and Culture at the End of the Nineteenth Century: The Will to Power" by Charles L. Sanford, pp. 726-739.

## Bibliography

- (T) Larmor, J. (editor) The Origins of Clerk Maxwell's Electric Ideas as Described in Familiar Letters to William Thomson, Cambridge Univ. Press (1937)
- (S,T) Lavine, Sigmund A. Steinmetz: Maker of Lightning, Dodd, Mead & Co., NY (1963)  
Biography of a pioneer in electric technology, written "for anyone from fourteen up."
- (T,S) Lockiesh, M. Color and Its Applications, Van Nostrand, NY 419 pp. (1921)  
This semipopular work is dated in the sense that many developments have been made since it was written, but it is just as entertaining and authoritative as ever. Good bibliography, but old.
- (S,T) MacDonald, D. K. C. Faraday, Maxwell and Kelvin (Science Study Series) Doubleday Anchor, Garden City, NY \$1.25 (1964)
- (T) Maclaurin, R. C. Light, Columbia Univ., NY 251 pp. (1909)  
This transcription of a series of ten popular lectures is a delightful account of optical phenomena in which the unity of science is explained. No bibliography.
- (T) MacLaren, Malcolm The Rise of the Electrical Industry During the Nineteenth Century, Princeton Univ. Press, Princeton, NJ (1943)
- (T,S) McDougal, W. L. and others Fundamentals of Electricity, 4th ed. revised by K. C. Graham and Others, American Technical Society, Chicago \$4.75 (1960)  
A non-mathematical treatment of fundamental electricity which also serves as good collateral reading for the high school physics student.
- (T,S) Mees, C. E. K. Photography, MacMillan, NY 2nd ed. 227 pp. (1942)  
A popularly written but accurate and well-illustrated story of one of the important applications of optics. No bibliography.
- (T,S) Michelson, A. A. Light Waves and Their Uses, University of Chicago Press (1907), reprinted by Phoenix as PSSS 508, 166 pp. (1961)  
A readable and well-illustrated transcription of a series of lectures describing the uses of the interference of light, no less informative and interesting for being based on the outmoded ether theory. No bibliography.
- (T,S) Michelson, A. A. Studies in Optics, University of Chicago Press (1927), reprinted by Phoenix as PSSS 514, 176 pp. (small)  
There is quite a bit of mathematics in this little description of some phenomena of physical optics (interference, the measurement of length, diffraction, measurement of velocity of light and such), but the clarity of writing is such that the book is fascinating for anyone with a knowledge of elementary calculus. No bibliography.
- (T,S) Miller, T. H. Brummitt, W. This is Photography, Doubleday, Garden City 260 pp. (1959)  
Primarily for the user, this book gives the underlying principles in simple terms. No bibliography.
- (T,S) Millikan, R. A. (abr. ed. by J. W. M. DuMond) The Electron, University of Chicago Press, Chicago \$6, Paperback Edition 45¢ (1963)  
An edited report of the experiments with the electron and elementary charge which won Millikan a Nobel Prize.
- (T,S) Minnaert, M. [The Nature of] Light and Colour in the Open Air, translated by Kremer-Priest, Dover, NY 362 pp. (1954)  
A homely and personal account of vision and optical phenomena in nature showing, despite the poor reproduction of the halftone illustrations, that one's appreciation of natural phenomena is heightened by scientific knowledge. No bibliography.



## Bibliography

- (1,2) Maxwell's Equations, James Clerk Maxwell, Electricity and Magnetism, 2nd ed., Cambridge University Press, 1891, reprinted in The Maxwell Equations, Cambridge University Press, 1964, pp. 1-104.
- (1,2) Murray, G. D. Classical Electrodynamics, 2nd ed., Wiley-Interscience, 1967, pp. 1-104.
- (1,2) Neumann, H. W. Dielectricity and Magnetism, 2nd ed., Wiley-Interscience, 1967, pp. 1-104.
- (1) Newton, Isaac Principia, Cambridge University Press, 1687, reprinted in The Newtonian Revolution, Cambridge University Press, 1962, pp. 1-104.
- (1) Nisenson, Warren Maxwell's Equations, Cambridge University Press, 1964, pp. 1-104.
- (1) Quine, C. G. Electricity and Magnetism, 2nd ed., Wiley-Interscience, 1967, pp. 1-104.
- (1) Salmer, C. H. Experiments and Demonstrations, 2nd ed., Wiley-Interscience, 1967, pp. 1-104.
- (T,S) Pierce, J. R. Electrons, Waves and Messages, Garden City, Doubleday Co. (1966) A fairly comprehensive study of electricity, magnetism, and electromagnetic radiation, especially in the field of electronics.
- (T,S) Planck, Michael From Immigrant to Inventor, Scribner (1921)
- (T) Parcell, F. W. Electricity and Magnetism, Berkeley Physics Course, volume 2, McGraw-Hill, NY (1963) This text will be used by many students majoring in physics at college during the next few years.
- (T,S) Penfield, Fred Rays: Visible and Invisible, Scribner, NY 204 pp. (1958) The physicist's discoveries and the applications of his discoveries are outlined in a lively manner by a facile writer. It is a bit graphic.
- (T,S) Riedman, S. P. The World Through Your Senses, Abelard-Schuman, NY, revised ed., 189 pp. (1962) A good description of how our senses function, designed for grades 7-10 (the eye and color get a chapter each) but with unjustifiably loose language in spots and some inaccurate diagrams; the teacher should be alert to correct the student's misconceptions. It is a bit graphic.





Bibliography

Wave-Field-Electricity Articles

1965

Light

1965 101 The Diffraction of Light by a Grating (M. J. R. Cantow, Jr., Ed. 1965)  
 102 The Diffraction of Light by a Grating (M. J. R. Cantow, Jr., Ed. 1965)

Sound

1965 103 The Diffraction of Sound by a Grating (H. L. Merwin)

Water

1965 104 The Diffraction of Water by a Grating (D. H. E. Durrant)  
 105 The Diffraction of Water by a Grating (D. H. E. Durrant)

Other

1965 106 The Diffraction of Light by a Grating (M. J. R. Cantow, Jr., Ed. 1965)

1965 107 The Diffraction of Light by a Grating (M. J. R. Cantow, Jr., Ed. 1965)

1965 108 The Diffraction of Light by a Grating (M. J. R. Cantow, Jr., Ed. 1965)

1965 109 The Diffraction of Light by a Grating (M. J. R. Cantow, Jr., Ed. 1965)

1965 110 The Diffraction of Light by a Grating (M. J. R. Cantow, Jr., Ed. 1965)

1965 111 The Diffraction of Light by a Grating (M. J. R. Cantow, Jr., Ed. 1965)

1965 112 The Diffraction of Light by a Grating (M. J. R. Cantow, Jr., Ed. 1965)

1965 113 The Diffraction of Light by a Grating (M. J. R. Cantow, Jr., Ed. 1965)

1965 114 The Diffraction of Light by a Grating (M. J. R. Cantow, Jr., Ed. 1965)

Interdisciplinary Science and Technology

1965 115 The Diffraction of Light by a Grating (M. J. R. Cantow, Jr., Ed. 1965)

1965 116 The Diffraction of Light by a Grating (M. J. R. Cantow, Jr., Ed. 1965)

FIELDS

Scientific American

1965 117 Advances in Field Emission (W.P. Dyke) The electron beam emitted by  
 118 cathode in an electric field has many uses.

1965 119 Simulating Gravitational Fields with Water (Amateur Scientist)

1965 120 The Magnetic Field of the Galaxy (Bers and Seielstad) Evidently the  
 121 field helps to hold galactic arms in place.

1967 122 Reversals of the Earth's Magnetic Field (A. Cox et al.) Volcanic rocks  
 123 indicate that there have been nine reversals in 3.6 million years.

1967 124 Fluid Models to Simulate Force Fields (Amateur Scientist)

## Bibliography

### American Journal of Physics

- 1967 Sept Potential Field Diagram for the Earth-Moon System Neglecting the Effect of the Sun (W.T. Scott)  
1967 April Force on a Wire in a Magnetic Field (A.C. Inglis)

### Physics Teacher

- 1964 Oct Magnetic Field About an Electron in Motion (Little Stirlers)  
1966 March Magnetic Pole (?) An Isolate North (R. Robinson)  
1966 April Particles and Fields in Physics (W.V. Horstien)

## ELECTRICITY

### Physics Teacher

- 1963 Oct Electromotive Force and the Law of Induction (M. Phillips)  
1963 Nov Electrostatic Demonstration (Sears)  
1963 Nov Faraday's Diary (Electrostatics)  
1964 Jan Demonstration Principles of Electrostatics (D.S. Ainslie)

**Bibliography**  
**Photographic Instrumentation**

- Marey Movement. Appleton, New York, 1896.  
 The multiple image, single frame photograph technique is described in this book. Illustrations from this work can be seen in Newhall's History of Photography (pg. 109) Simon and Schuster, New York, 1949. There is no reference to Marey in Morgans' Encyclopedia of Photography, Graystone Press, New York, 1963. There should be. See Edgerton and Killian.
- Conrad, et al. Photography as a Scientific Instrument. Blackie and Son, London, 1923.  
 Contents: The History of Photography, The Elementary Optics of Photography, Photographic Optics, The Theory of Photographic Processes and Methods, Astronomical Photography, Application of Photography in Physics, Photography in the Engineering and Metallurgical Industries, Photomicrography, Photographic Surveying, Aeronautical Photography, Color Photography, Photography Applied to Printing, the Technique of Kymographography, The Camera as a Witness and Detective.
- Quayle. Spark Photography and Its Applications to Some Problems in Ballistics. Scientific Paper 508. Bureau of Standards, Washington, 1925.  
 Methods used in the United States which are quite similar to those used at present.
- Cranz. Experimentelle Ballistik, Vol. III. Springer, Berlin, 1927.  
 Excellent summarization of work done prior to World War II. For discussion of Cranz see the Proceedings of the Fourth International Congress on High Speed Photography, Cologne. He was Schardin's mentor.
- Edgerton & Killian. Flash Haie. Cushman & Flint, Boston, 1939. Ibid. Charles T. Branford, Boston, 1954.  
 Primarily a picture book. First edition has excellent bibliography on electronic flash photography. Second edition brings this bibliography up to 1954.
- Waddell. High Speed Photography. Bell Telephone Laboratories, New York, 1947.  
 Small edition printed for classes given by the author at University of Southern California and U.C.I.A. Laboratories on rotating prism cameras. Early history covered in illustrations.
- Tupholme. Photography in Engineering. Chemical Publishing Co., Brooklyn, New York, 1949.  
 An explanation of the table of contents shows that new fields of endeavor have entered photographic instrumentation: Photography of Drawings and Documents, Photography in the Laboratory, High Speed Photography, Radiography, X-ray and Electron Diffraction and Microchemistry, Processing and Storing X-ray Material, Infrared Photography, Instructional Motion Pictures.
- Sakharov. High Speed Motion Pictures. Moscow, 1950.  
 This is the first of the newer texts on current photo-optical instrumentation. Partial translation available from the original Russian.
- Fayolle and Naclin. Photographie Instantanée & Cinématographie Ultra Rapide. Editions de la Revue D'Optique, Paris, 1950.  
 There are excellent descriptions of the state of art in ballistic and other ultra-high speed techniques. It is to be emphasized that Bell, Eichelart and Fayolle were French pioneers in spark photography.
- C. Osterman. The Photographic Study of Rapid Events. Oxford Press, Oxford, England, 1951.
- Jones. High Speed Photography. Wiley, New York, 1952.  
 The above two books are primarily elementary texts but there are deficiencies, particularly in the field of light science. There have been many significant advances in the state-of-art since 1952.
- Science and Applications of Photography. Royal Photographic Society, London, 1955.  
 An excellent compilation of papers presented at the Centennial of the Royal.
- Waddell and Waddell. Photographic Motion Analysis. Industrial Laboratories Publishing Co., Chicago, 1955.  
 The objective of this very limited published edition was to acquaint engineers with a working knowledge of photo-optical instrumentation.
- Muybridge. The Human Figure. Dover, New York, 1955.  
 M. bridge. Animals in Motion. Dover, New York, 1957.  
 These two books are excellent compilations of the best of Muybridge's work in 1880 and 1890. The introductory text explains the techniques that were used to obtain these early studies and analyses of motion studies.
- Courtney Pratt. Image Dissection in High Speed Photography. Helwich, Darmstadt, 1958.  
 A good summarization of the exotic techniques of ultra-high speed photography with a strong slanting toward Courtney-Pratt's work.

## Bibliography Photographic Instrumentation

- Hyzer. Engineering and Scientific High-speed Photography. Macmillan, New York, 1962.  
The best to date of the English language texts on high speed photography. The rotating prism theory is a little weak.
- Shafton and Hawley. Photographic Instrumentation. Society of Photographic Instrumentation Engineers, Redondo Beach, Calif. 1962.
- Boys Soap Bubble 1911. Dover, New York, 1959. Also Doubleday Garden City, New York, 1959.
- Worthington. A Study of Splashes, 1854-1907. Macmillan, N. Y., 1960.  
These two books are very enlightening when one considers the obstacles that they had to overcome. The Worthington pictures compare favorably with the Edgerton splashes. Boys designed a camera which was later applied to the General Electric lightning camera.
- Dubowik. Photographic Registration of High Speed Events. Moscow, 1964.  
The best of the photo instrumentation tests. This is now being translated from the Russian.  
It is unfortunate that Edgerton and Schardin have not published texts and/or complete collections of their papers. A text on photo optical instrumentation by the Waddells is well on the way. Numerous changes were and are being made based on the experiences of teaching at the University of California at Los Angeles.
- High Speed Photography. Society of Motion Picture and Television Engineers, New York.  
Series I Volumes and year as follows: 1-2 1949, 3-1951, 4-1952, 5-1954\*, 6-1957. Series 2: 1-2-1960.
- Proceedings of International Congresses on High Speed Photography.  
Dunod, Paris, 1956. Second Butterworths Scientific Publications, London, 1957. Third Helwich, Darmstadt, 1959. Fourth Society of Motion Picture and TV Engineers, New York, 1962. Fifth and H. D. Epenk, Willink and Joon, Haarlem, 1963. Sixth.

### Miscellaneous Publications

- Clark. Infra Red Photography. Wiley, New York.  
Cox. Photographic Optics. Focal Press, London.  
Eder. Handbuch der Photographie. Geschie, Vol III Springer, Berlin, see Epstein.  
Eder. Light for Students. Macmillan, London, 1954.  
Epstein. History of Photography. Translation of Eder's History. Columbia University Press, New York.

(\*Proceedings of First International Congress on High Speed Photography)

- Evans. Introduction to Color. Wiley, New York, 1948.  
Evans. Eye, Film and Camera in Color Photography. Wiley, New York, 1953.  
Hebball and Cox. Engineering Optics. Pitman, London, 1956.  
James and Higgins. Fundamentals of Photographic Theory. Morgan and Morgan, New York, 1960.  
Jacobs. Essentials of Optical Engineering. McGraw Hill, New York, 1945.  
Jerkkin and White. Fundamentals of Optics. McGraw Hill, New York, 1957.  
Judge. Stereoscopic Photography. Chapman and Hill, London, 1950.  
Kingslake. Lenses in Photography. Barnes, New York, 1963.  
Lumiere. Introduction to Photographic Principles. Dover, New York, 1965.  
Manual of Photogrammetry. American Society of Photogrammetry, Washington, 1952.  
Miles. The Theory of the Photographic Process. Macmillan, New York, 1954. Being revised.  
Michaels. Research Films in Biology, Anthropology, Psychology, and Medicine. Academic Press, New York, 1955.  
Minocent. Light and Color. Dover, New York, 1974.  
Neblette. Photography. Van Nostrand, Princeton, New Jersey.  
Southall. Mirrors, Prisms, and Lenses. Macmillan, New York, 1945.

### Light Sources\*

- Lamp Bulletins, ED1 and ED2. General Electric Company, NELA Park, Cleveland, Ohio.  
Glow Lamp Manual. General Electric Company, NELA Park, Cleveland, Ohio.  
Flashtubes. General Electric Company, NELA Park, Cleveland, Ohio.  
High Speed Photography. General Radio Company, Boston, Mass.  
Loeck and Verbeck. Artificial Light and Photography. Elsevier Press, New York, 1952.

### Data and Handbooks

- The Kodak Data Books and Handbooks and abridged Scientific Publications published by Eastman Kodak Company, Rochester, NY, contain a wealth of information on techniques, materials, and science. The Kodak Handbooks, published by Kodak Ltd., Harrow, England, are also valuable adjuncts to the library. Ilford Ltd., Ilford, England, published a series of technical handbooks of value.

\*There are no good texts on light sources for photographic instrumentation.



## Suggested Answers to Unit 4 Tests

## Test A

ITEM	ANSWER	SECTION OF UNIT	PROPORTION OF TEST SAMPLE ANSWERING ITEM CORRECTLY
1	B	13.3	0.73
2	E	14.3	0.67
3	C	13.3	0.43
4	C	14.3	0.40
5	C	14.4	0.27
6	B	13.2	0.57
7	D	16.5	0.73
8	C	16.2	0.70
9	B	16.2	0.40
10	D	14.10	0.77
11	D	15.4	0.67
12	C	15.4	0.83
13	B	16.2	0.63
14	A	15.3	0.47
15	D	15.4	0.37

Answers Test A

Group I

1. Section of Unit: 16.4

Hertz found:

- a) that electromagnetic waves reflect, refract and interfere in a manner similar to light waves.
- b) that the velocity of electromagnetic waves and light waves are the same.

He concluded that both light waves and electromagnetic waves could be accounted for by Maxwell's electromagnetic theory.

2. Sections of Unit: 16.2, 16.3

Maxwell predicted:

- a) that electromagnetic waves of many different frequencies could exist.
- b) that electromagnetic waves exert a pressure on any surface that reflects or absorbs them.

3. Section of Unit: 14.10

$$\begin{aligned} \text{Power} &= VI \\ &= (12 \text{ volts})(100 \text{ amps}) \\ &= 1200 \text{ watts} \end{aligned}$$

4. Sections of Unit: 14.11—14.13

- a) A magnetic compass needle held close to a current-carrying wire will align itself perpendicular to the wire.
- b) Two parallel current-carrying wires held close together will exert forces on each other.
- c) An insulated wire carrying current coiled around a piece of iron will cause the iron to become magnetic.

5. Sections of Unit: 14.3, 14.4

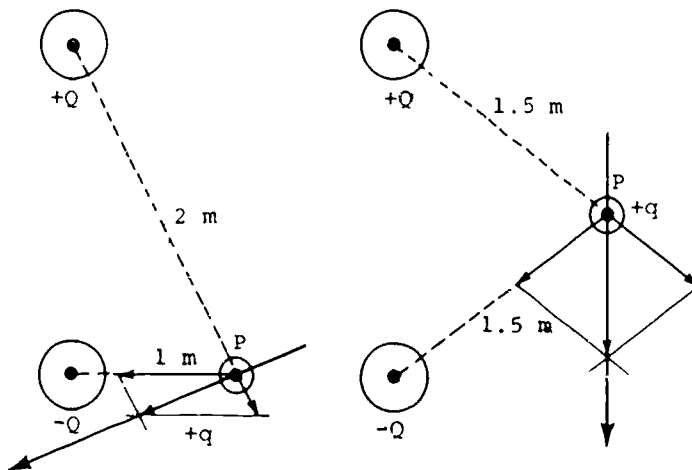

Group 11

6. Section of Unit: 15.8

a)  $P = I \cdot R$   
 $= (0.50 \text{ ampere})^2 (510 \text{ ohm})$   
 $= (.25 \text{ amp} ) (510 \text{ ohm})$   
 $= 130.0 \text{ watts}$

b)

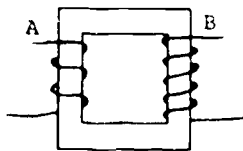

An alternating current in the primary coil (A) changes the magnetic field in the iron ring. The change in the magnetic field in the part of the ring near the secondary coil (B) induces a current in the secondary coil. If the secondary coil has more turns than the primary, the voltage across the secondary will be greater than the voltage across the primary. If the secondary has fewer turns than the primary, the voltage across the secondary will be less than the voltage across the primary.

7. Section of Unit: 1.4

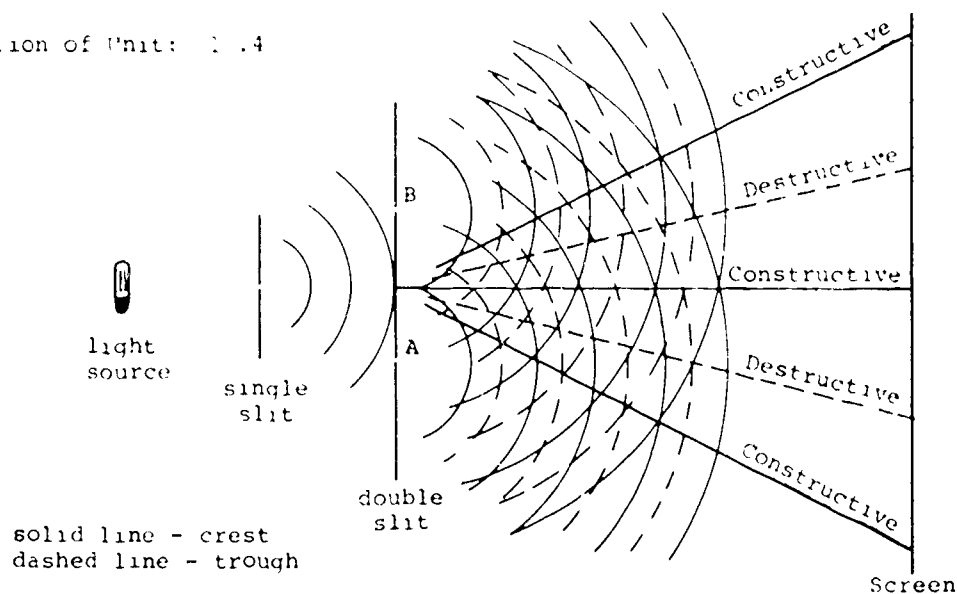

An adequate answer to this question should involve some discussion of most of the following facets of the experiment.

- the nature of the light source
- the function of the single slit
- the function of the double slits
- the regions of constructive and destructive interference
- the pattern seen on the screen
- relative dimensions of parts of the apparatus where this information is vital to the experiment

Suggested Answers to Unit 4 Tests

Test B

ITEM	ANSWER	SECTION OF UNIT	PROPORTION OF TEST SAMPLE ANSWERING ITEM CORRECTLY
1	L	14.3	0.34
2	E	14.4	0.75
3	C	16.5	0.73
4	E	14.3	0.69
5	A	13.4	0.60
6	D	13.4	0.37
7	B	13.5	0.72
8	D	16.3	0.64
9	C	13.3	0.39
10	E	14.3	0.58
11	C	14.3, .4	0.69
12	D	13.6	0.85
13	B	13.2, .3	0.52
14	F	.6	0.60
15	E	16.7	0.51

## Answers Test 5

at 1

### 1. Section of Unit: 15.1

A satisfactory answer to this question may involve a brief discussion of two of the following effects of the introduction of electrical power. This list does not include all possible answers.

- a) the impact of electricity on industry
- b) the social effects of machinery replacing physical labor
- c) the trend towards a decentralized population brought about by rural electrification
- d) the unification of the country through the use of electrically operated systems of communications

### 2. Section of Unit: 13.3

The nature philosophers objected to Newton's theory of color because they found the scientific procedure of dissecting and analyzing natural phenomena distasteful. They felt that it was necessary to consider the unifying principles of all natural forces in order to understand nature as a whole.

### 3. Section of Unit: 14.4

A field is a set of values attached to every point in space; the values are, in general, functions of both position and time. The field idea is often invoked intuitively or for mathematical convenience to describe a region of interaction in which there are different amounts of influence produced by some source, and to avoid direct action at a distance.

### 4. Section of Unit: 16.5

X rays are readily absorbed by bone, whereas they pass through organic matter such as flesh. In addition, x rays have the ability to expose photographic film.

### 5. Section of Unit: 16.5

The following list is not intended to provide all the possible reasons for believing that electromagnetic waves carry energy.

- a) Energy must be supplied to a source of electromagnetic radiation.
- b) When electromagnetic waves are absorbed, the absorbing material is heated.
- c) Electromagnetic radiations exert pressure on targets.
- d) Hertz discovered that the sparking of an induction coil caused similar sparking to occur in his receiver loop.

Answers Test 8

1. The first wire is  
attached to  
the first wire length  
is scattered  
the second wire  
is attached to the

the second wire of  
the wire are  
to the side.  
the wire are

111/112

Suggested Answers to Unit 4 Tests

Test C

ITEM	ANSWER	SECTION OF UNIT	PROPORTION OF TEST SAMPLE ANSWERING ITEM CORRECTLY	ITEM	ANSWER	SECTION OF UNIT	PROPORTION OF TEST SAMPLE ANSWERING ITEM CORRECTLY
1	C	14.8	0.69	21	B	13.3	0.73
2	D	13.6	0.85	22	B	13.3	0.89
3	D	16.1	0.58	23	B	15.4	0.60
4	E	14.4	0.64	24	A	15.4	0.70
5	C	14,16	0.90	25	D	13.6	0.85
6	B	14.3		26	D	16.7	0.44
7	B	14.4	0.57	27	C	14.11	0.77
8	C	13.3	0.46	28	E	14.3	0.67
9	C	16.2	0.63	29	D	14.13	0.42
10	B	13.3	0.57	30	A	13.4	0.55
11	E	14.3	0.59	31	D	13.4	0.34
12	B	14.13		32	B	13.5	0.53
13	E	16.7	0.38	33	D	14.3	0.43
14	C	general	0.76	34	B	16.2	0.47
15	E	14.13,16.2	0.44	35	A	14.12	0.50
16	D	16.5	0.67	36	D	16.1	0.37
17	E	15.8	0.44	37	C	15.8	0.74
18	C	general	0.59	38	A	14.2	0.49
19	A	16.3	0.43	39	A	14.13	0.67
20	C	14.11	0.67	40	D	15.8	0.51

## Suggested Answers to Unit 4 Tests

## Test D

## Group One

## 1. Section of Unit: 13.3

As light enters the block of glass, its velocity decreases, its wavelength decreases and its frequency remains constant.

## 2. Section of Unit: 14.13

A stream of charged particles, mainly from the sun but also from outer space, continually sweeps past the earth. Many of these particles are deflected into spiral paths by the earth's magnetic field and are trapped.

## 3. Section of Unit: 16.2, 16.3

In developing his electromagnetic theory, Maxwell devised a mechanical model that provided the connections among the electrical and magnetic quantities observed by Faraday and others. The ether was a constituent part of this mechanical model. However, once Maxwell found the desired relations between the electric and magnetic fields, he was free to discard the mechanical model. Maxwell's electromagnetic theory is independent of any assumption concerning the ether. His model developed for matter can be applied to space that is free of matter. Under all circumstances, an electric field that is changing with time generates a magnetic field.

## 4. Section of Unit: 16.5

Because both x rays and radio waves are electromagnetic radiations, they can both be refracted, reflected and diffracted, and both exhibit interference.

## 5. Section of Unit: 16.2

Include a sample of the material in a circuit with a battery and a current detector. If the current flow is constant, or changes very little, the substance is a conductor. If a current cannot be detected, the substance is an insulator.



Answers Test D

Group Two

6. Section of Unit: 14.3

Force on C due to A:

$$F_{CA} = \frac{kq_C q_A}{R}$$

$$= \frac{\left(9 \cdot 10^9 \frac{\text{Nm}}{\text{coulomb}^2}\right) \left(1 \cdot 10^{-7} \text{ coulomb}\right) \left(-1 \cdot 10^{-7} \text{ coulomb}\right)}{\left(\frac{1}{10} \text{ m}\right)^2}$$

$$= -0.90 \text{ N (a 0.9 newton force towards A).}$$

Force on C due to B:

$$F_{CB} = \frac{kq_C q_B}{R}$$

$$= \frac{\left(9 \cdot 10^9 \frac{\text{Nm}}{\text{coulomb}^2}\right) \left(+2 \cdot 10^{-7} \text{ coulomb}\right) \left(-1 \cdot 10^{-7} \text{ coulomb}\right)}{\left(\frac{1}{3} \text{ m}\right)^2}$$

$$= -0.16 \text{ N (a 0.16 newton force towards B).}$$

Net force on C:

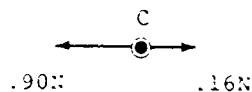

$$F_C = (.9 - .16) \text{ N}$$

$$= 0.74 \text{ N (a 0.74 newton force towards A).}$$

7. Section of Unit: 13.6

The longer a wave is compared to the size of an obstacle, the less it is scattered. Thus, in areas where the air is clear, sunlight is scattered by air molecules and particles of dust or water vapor. These particles are smaller than most wavelengths of light. Consequently, only light of short wavelengths—blue—is scattered, and the sky seems blue. However, when the air is polluted, larger particles are suspended in the air. These particles scatter sunlight of longer wavelengths. Consequently, reds and oranges mixed with blue are seen in the sky.

8. Section of Unit: 16.7

- a) The special theory of relativity assumes that all of physics and electromagnetism, as well as mechanics, satisfies the relativity principle: there is no way to distinguish among frames of reference that have a constant relative velocity.
- b) The speed of light in free space is the same for all observers, whatever their velocities relative to each other or to the light source.

## Index to Unit 4 Teacher Guide

- A  
   A, 47-49  
   A, 51  
   A, 71  
   G, 10-11, 22  
   S, 109-107  
   B, 109-111  
   C, 113  
   D, 115-117  
   E, 119-121  
   F, 123-125  
   G, 127-129  
   H, 131-133  
   I, 135-137  
   J, 139-141  
   K, 143-145  
   L, 147-149  
   M, 151-153  
   N, 155-157  
   O, 159-161  
   P, 163-165  
   Q, 167-169  
   R, 171-173  
   S, 175-177  
   T, 179-181  
   U, 183-185  
   V, 187-189  
   W, 191-193  
   X, 195-197  
   Y, 199-201  
   Z, 203-205  
 B  
   B, 109-111  
   C, 113  
   D, 115-117  
   E, 119-121  
   F, 123-125  
   G, 127-129  
   H, 131-133  
   I, 135-137  
   J, 139-141  
   K, 143-145  
   L, 147-149  
   M, 151-153  
   N, 155-157  
   O, 159-161  
   P, 163-165  
   Q, 167-169  
   R, 171-173  
   S, 175-177  
   T, 179-181  
   U, 183-185  
   V, 187-189  
   W, 191-193  
   X, 195-197  
   Y, 199-201  
   Z, 203-205  
 C  
   C, 113  
   D, 115-117  
   E, 119-121  
   F, 123-125  
   G, 127-129  
   H, 131-133  
   I, 135-137  
   J, 139-141  
   K, 143-145  
   L, 147-149  
   M, 151-153  
   N, 155-157  
   O, 159-161  
   P, 163-165  
   Q, 167-169  
   R, 171-173  
   S, 175-177  
   T, 179-181  
   U, 183-185  
   V, 187-189  
   W, 191-193  
   X, 195-197  
   Y, 199-201  
   Z, 203-205  
 D  
   D, 115-117  
   E, 119-121  
   F, 123-125  
   G, 127-129  
   H, 131-133  
   I, 135-137  
   J, 139-141  
   K, 143-145  
   L, 147-149  
   M, 151-153  
   N, 155-157  
   O, 159-161  
   P, 163-165  
   Q, 167-169  
   R, 171-173  
   S, 175-177  
   T, 179-181  
   U, 183-185  
   V, 187-189  
   W, 191-193  
   X, 195-197  
   Y, 199-201  
   Z, 203-205  
 E  
   E, 119-121  
   F, 123-125  
   G, 127-129  
   H, 131-133  
   I, 135-137  
   J, 139-141  
   K, 143-145  
   L, 147-149  
   M, 151-153  
   N, 155-157  
   O, 159-161  
   P, 163-165  
   Q, 167-169  
   R, 171-173  
   S, 175-177  
   T, 179-181  
   U, 183-185  
   V, 187-189  
   W, 191-193  
   X, 195-197  
   Y, 199-201  
   Z, 203-205  
 F  
   F, 123-125  
   G, 127-129  
   H, 131-133  
   I, 135-137  
   J, 139-141  
   K, 143-145  
   L, 147-149  
   M, 151-153  
   N, 155-157  
   O, 159-161  
   P, 163-165  
   Q, 167-169  
   R, 171-173  
   S, 175-177  
   T, 179-181  
   U, 183-185  
   V, 187-189  
   W, 191-193  
   X, 195-197  
   Y, 199-201  
   Z, 203-205  
 G  
   G, 127-129  
   H, 131-133  
   I, 135-137  
   J, 139-141  
   K, 143-145  
   L, 147-149  
   M, 151-153  
   N, 155-157  
   O, 159-161  
   P, 163-165  
   Q, 167-169  
   R, 171-173  
   S, 175-177  
   T, 179-181  
   U, 183-185  
   V, 187-189  
   W, 191-193  
   X, 195-197  
   Y, 199-201  
   Z, 203-205  
 H  
   H, 131-133  
   I, 135-137  
   J, 139-141  
   K, 143-145  
   L, 147-149  
   M, 151-153  
   N, 155-157  
   O, 159-161  
   P, 163-165  
   Q, 167-169  
   R, 171-173  
   S, 175-177  
   T, 179-181  
   U, 183-185  
   V, 187-189  
   W, 191-193  
   X, 195-197  
   Y, 199-201  
   Z, 203-205  
 I  
   I, 135-137  
   J, 139-141  
   K, 143-145  
   L, 147-149  
   M, 151-153  
   N, 155-157  
   O, 159-161  
   P, 163-165  
   Q, 167-169  
   R, 171-173  
   S, 175-177  
   T, 179-181  
   U, 183-185  
   V, 187-189  
   W, 191-193  
   X, 195-197  
   Y, 199-201  
   Z, 203-205  
 J  
   J, 139-141  
   K, 143-145  
   L, 147-149  
   M, 151-153  
   N, 155-157  
   O, 159-161  
   P, 163-165  
   Q, 167-169  
   R, 171-173  
   S, 175-177  
   T, 179-181  
   U, 183-185  
   V, 187-189  
   W, 191-193  
   X, 195-197  
   Y, 199-201  
   Z, 203-205  
 K  
   K, 143-145  
   L, 147-149  
   M, 151-153  
   N, 155-157  
   O, 159-161  
   P, 163-165  
   Q, 167-169  
   R, 171-173  
   S, 175-177  
   T, 179-181  
   U, 183-185  
   V, 187-189  
   W, 191-193  
   X, 195-197  
   Y, 199-201  
   Z, 203-205  
 L  
   L, 147-149  
   M, 151-153  
   N, 155-157  
   O, 159-161  
   P, 163-165  
   Q, 167-169  
   R, 171-173  
   S, 175-177  
   T, 179-181  
   U, 183-185  
   V, 187-189  
   W, 191-193  
   X, 195-197  
   Y, 199-201  
   Z, 203-205  
 M  
   M, 151-153  
   N, 155-157  
   O, 159-161  
   P, 163-165  
   Q, 167-169  
   R, 171-173  
   S, 175-177  
   T, 179-181  
   U, 183-185  
   V, 187-189  
   W, 191-193  
   X, 195-197  
   Y, 199-201  
   Z, 203-205  
 N  
   N, 155-157  
   O, 159-161  
   P, 163-165  
   Q, 167-169  
   R, 171-173  
   S, 175-177  
   T, 179-181  
   U, 183-185  
   V, 187-189  
   W, 191-193  
   X, 195-197  
   Y, 199-201  
   Z, 203-205  
 O  
   O, 159-161  
   P, 163-165  
   Q, 167-169  
   R, 171-173  
   S, 175-177  
   T, 179-181  
   U, 183-185  
   V, 187-189  
   W, 191-193  
   X, 195-197  
   Y, 199-201  
   Z, 203-205  
 P  
   P, 163-165  
   Q, 167-169  
   R, 171-173  
   S, 175-177  
   T, 179-181  
   U, 183-185  
   V, 187-189  
   W, 191-193  
   X, 195-197  
   Y, 199-201  
   Z, 203-205  
 Q  
   Q, 167-169  
   R, 171-173  
   S, 175-177  
   T, 179-181  
   U, 183-185  
   V, 187-189  
   W, 191-193  
   X, 195-197  
   Y, 199-201  
   Z, 203-205  
 R  
   R, 171-173  
   S, 175-177  
   T, 179-181  
   U, 183-185  
   V, 187-189  
   W, 191-193  
   X, 195-197  
   Y, 199-201  
   Z, 203-205  
 S  
   S, 175-177  
   T, 179-181  
   U, 183-185  
   V, 187-189  
   W, 191-193  
   X, 195-197  
   Y, 199-201  
   Z, 203-205  
 T  
   T, 179-181  
   U, 183-185  
   V, 187-189  
   W, 191-193  
   X, 195-197  
   Y, 199-201  
   Z, 203-205  
 U  
   U, 183-185  
   V, 187-189  
   W, 191-193  
   X, 195-197  
   Y, 199-201  
   Z, 203-205  
 V  
   V, 187-189  
   W, 191-193  
   X, 195-197  
   Y, 199-201  
   Z, 203-205  
 W  
   W, 191-193  
   X, 195-197  
   Y, 199-201  
   Z, 203-205  
 X  
   X, 195-197  
   Y, 199-201  
   Z, 203-205  
 Y  
   Y, 199-201  
   Z, 203-205  
 Z  
   Z, 203-205  
 Earth's field, 68  
   magnetic, 80  
 Einstein, 45  
 Electric field, 57, 74  
   force, 63  
   potential, 42  
 Electricity, 43  
 Electromagnetism, 63  
 Electromagnetic spectrum, 85, 86  
 Electron  
   beam tube, 70  
 Electrophorus, 53  
 Electroscopes, 51-53  
 Electrostatics, 41  
   demonstrations, 51  
 Exponent rules, 79-83  
 Fermi, 40  
 Feynman, 1, 63-75  
   diagrams, 12, 20  
 Fibers, 87  
   optical, 51  
 Fields, 57  
   electric, 57  
   magnetic, 44  
   of force, 42  
   of induction, 85  
   of light, 85  
   of magnetism, 63  
   of sound, 79  
   of vision, 80  
   of waves, 87  
 Filaments, 71  
 Films, 1, 47  
   of light, 47  
 Flashes, written 63  
 Flux  
   of current, 54, 55  
   of magnetism, 63  
   of light, 44  
 Franklin, 42  
 Fresnel's, 73, 75  
 Fresnel, 40  
 Gauss, 40  
 Geometrical optics, 38  
 Gilbert, 41  
 Goethe, 41  
 Grass seeds, 88  
 Gravitational mass, 87  
 Gravity, 87  
 Herapath, 40  
 Hertz, 39  
 Huygens, 39  
 Ice-pail, 51  
 Induced charge, 65  
 Induction, electrostatic, 52  
 Interference, 58, 62  
 Kilograms, 87  
 Kit, microwave, 81  
 "Lectron" series, 91  
 Light, ultraviolet, 53  
 Lloyd's mirror, 58  
 Loops, 1, 47  
 Lorentz, 44  
 Loudspeaker, 57, 78, 82  
 Magnetic  
   effect of current, 44  
   field, 74  
   pole, 41  
 Marconi, 43  
 Magnet, 35, 66  
 Magnetostatic, 87  
 Maxwell, 44, 42  
 Microphone, 78  
 Microwave apparatus, 81  
 Microwave, 57-59, 77  
 Millikan, 42

## Index

- Modulation, 64, 77, 78, 82
  - amplitude, 72, 73
- Multi-media schedule, 2-4
- Neon bulb, 75
- Newton, 39-42
- Null method, 79
- Oersted, 43, 84
- Ohm's law, 42
- Optics, 38
- Oscillator, 78
- Oscilloscope, 82
- Overview, 1
- Physical optics, 38
- Pitbull, 53
- Poisson, 40
- Polarization, 59
- Polaroid, 41, 59
- Poles
  - magnetic, 41
- Potential
  - electric, 42
- Reader articles, 1, 48, 49
- Reasout, 82
- Receiving circuit, 76
- Resistor, 75
- Resonance, 74
- Resonant circuit, 75
- Resources chart, 6-7, 11, 14, 18
- Ritter, 44
- Römer, 38, 39, 90
- Schedule,
  - multi-media, 3, 4
  - blocks, 5, 9, 15, 17
- Sensitivity, 80
- Shielding, 88
- Signal generator, 75
- Solutions
  - Study Guide, 23-37
- Speed of light, 39
- Squire wave, 73, 75
- Standing waves, 61
- Summary
  - aids, 47-49
  - experiments, 12, 20
- Telescope, 39
- Test bodies, 87
- Tests, answers, 105-117
- Fourmilina, 59
- Transmitter, 75, 77
- Transparencies, 1, 47
- Trouble shooting, 83
- Tuned circuits, 74
- Turntable oscillators, 71, 72
- Ultraviolet light, 53
- Vacuum, 39
  - pump, 70
- Variac, 56
- Waves standing, 61
- Wavelength, 40, 41
  - of light, 63
- Whittaker, 4
- Wimshurst machine, 57
- Work, 34
- Young, 40
  - experiment of, 63
- Zero adjustment, 80

Project Physics **Text**

An Introduction to Physics **4** Light and Electromagnetism



Authorized Interim Version 1968-69

Distributed by Holt, Rinehart and Winston, Inc. New York Toronto

The Project Physics course was developed through the contributions of many people—the following is a partial list of these contributors. (The affiliations indicated are those just prior to or during association with the Project.)

#### Directors of Harvard Project Physics

Gerald Holton, Dept. of Physics, Harvard University  
F. James Rutherford, Capistrano High School, San Bruno, Calif.  
Fletcher G. Watson, Harvard Graduate School of Education

#### Advisory Committee

F. C. Begle, Stanford University, Calif.  
Paul F. Brandwein, Harcourt Brace & World, Inc.,  
San Francisco, Calif.  
Robert Brode, University of California, Berkeley  
Erwin Hebert, University of Wisconsin, Madison  
Harry Kelly, North Carolina State College, Raleigh  
William C. Kelly, National Research Council, Washington, D. C.  
Philippe LeCorbeiller, New School for Social Research,  
New York, N.Y.  
Thomas Miner, Garden City High School, New York, N.Y.  
Philip Morrison, Massachusetts Institute of Technology,  
Cambridge  
Ernest Nagel, Columbia University, New York, N.Y.  
Leonard K. Nash, Harvard University  
I. I. Rabi, Columbia University, New York, N.Y.

Copyright © 1968, Project Physics Incorporated

Copyright is claimed until December 31, 1968. After December 31, 1968 all portions of this work not identified herein as the subject of previous copyright shall be in the public domain. The authorized interim version of the Harvard Project Physics course is being distributed at cost by Holt, Rinehart and Winston, Inc. by arrangement with Project Physics Incorporated, a non-profit educational organization. All persons making use of any part of these materials are requested to acknowledge the source and the financial support given to Project Physics by the agencies named below, and to include a statement that the publication of such material is not necessarily endorsed by Harvard Project Physics or any of the authors of this work.

The work of Harvard Project Physics has been financially supported by the Carnegie Corporation of New York, the Ford Foundation, the National Science Foundation, the Alfred P. Sloan Foundation, the United States Office of Education, and Harvard University.

#### Staff and Consultants

Andrew Ahlgren, Maine Township High School, Park Ridge, Ill.  
I. K. Akers, Oak Ridge Associated Universities, Tenn.  
Roger A. Albrecht, Osage Community Schools, Iowa  
David Anderson, Oberlin College, Ohio  
Gary Anderson, Harvard University  
Donald Armstrong, American Science Film Association,  
Washington, D.C.  
Sam Ascher, Henry Ford High School, Detroit, Mich.  
Ralph Atherton, Talawanda High School, Oxford, Ohio  
Albert V. Baez, UNLSCO, Paris  
William C. Banick, Fulton High School, Atlanta, Ga.  
Arthur Bardige, Nova High School, Fort Lauderdale, Fla.  
Rolland B. Bartholomew, Henry M. Gunn High School,  
Palo Alto, Calif.  
O. Theodor Benfey, Earlham College, Richmond, Ind.  
Richard Berendzen, Harvard College Observatory  
Alfred M. Bork, Reed College, Portland, Ore.  
Alfred Brenner, Harvard University  
Robert Bridgman, Harvard University  
Richard Brinckerhoff, Phillips Exeter Academy, Exeter, N.H.  
Donald Brittain, National Film Board of Canada, Montreal  
Joan Bromberg, Harvard University  
Vinson Bronson, Newton South High School, Newton Centre, Mass.  
Stephen G. Brush, Lawrence Radiation Laboratory, University of  
California, Livermore  
Michael Butler, CIASA Films Mundiales, S.A., Mexico  
Leon Callihan, St. Mark's School of Texas, Dallas  
Douglas Campbell, Harvard University  
Dean R. Casperson, Harvard University  
Bobby Chambers, Oak Ridge Associated Universities, Tenn.  
Robert Chesley, Thacher School, Ojai, Calif.  
John Christensen, Oak Ridge Associated Universities, Tenn.  
Dora Clark, W. G. Winloe High School, Raleigh, N.C.  
David Clarke, Browne and Nichols School, Cambridge, Mass.  
Robert S. Cohen, Boston University, Mass.

90123 69 9876543

03-073450-9

- Brother Columban Francis, F.S.C., Mater Christi Diocesan High School, Long Island City, N.Y.
- Arthur Compton, Phillips Exeter Academy, Exeter, N.H.
- David I. Cone, Los Altos High School, Calif.
- William Cooley, University of Pittsburgh, Pa.
- Ann Couch, Harvard University
- Paul Cowan, Hardin-Simmons University, Abilene, Tex.
- Charles Davis, Fairfax County School Board, Fairfax, Va.
- Michael Dentamaro, Senn High School, Chicago, Ill.
- Raymond Dittman, Newton High School, Mass.
- Elsa Dorfman, Educational Services Inc., Watertown, Mass.
- Vadim Drozin, Bucknell University, Lewisburg, Pa.
- Neil F. Dunn, Burlington High School, Mass.
- R. T. Ellickson, University of Oregon, Eugene
- Thomas Embry, Nova High School, Fort Lauderdale, Fla.
- Walter Epstein, Rensselaer Polytechnic Institute, Troy, N.Y.
- Herman Epstein, Brandeis University, Waltham, Mass.
- Thomas F. B. Ferguson, National Film Board of Canada, Montreal
- Thomas von Foerster, Harvard University
- Kenneth Ford, University of California, Irvine
- Robert Gardner, Harvard University
- Fred Geis, Jr., Harvard University
- Nicholas J. Georgis, Staples High School, Westport, Conn.
- H. Richard Gerfin, Simon's Rock, Great Barrington, Mass.
- Owen Gingerich, Smithsonian Astrophysical Observatory, Cambridge, Mass.
- Stanley Goldberg, Antioch College, Yellow Springs, Ohio
- Leon Goutevenier, Paul D. Schreiber High School, Port Washington, N.Y.
- Albert Gregory, Harvard University
- Julie A. Goetze, Weeks Jr. High School, Newton, Mass.
- Robert D. Haas, Claremont High School, San Diego, Calif.
- Walter C. Hagenbuch, Plymouth-Whitmarsh Senior High School, Plymouth Meeting, Pa.
- John Harris, National Physical Laboratory of Israel, Jerusalem
- Jay Hauben, Harvard University
- Robert K. Henrich, Kennewick High School, Washington
- Peter Heller, Brandeis University, Waltham, Mass.
- Banesh Hoffmann, Queens College, Flushing, N.Y.
- Elisha R. Huggins, Dartmouth College, Hanover, N.H.
- Ilovd Ingraham, Grant High School, Portland, Ore.
- John Jared, John Renne High School, Pointe Claire, Quebec
- Harald Jensen, Lake Forest College, Ill.
- John C. Johnson, Worcester Polytechnic Institute, Mass.
- Kenneth J. Jones, Harvard University
- LeRoy Kallenmeyn, Benson High School, Omaha, Neb.
- Irving Kaplan, Massachusetts Institute of Technology, Cambridge
- Benjamin Karp, South Philadelphia High School, Pa.
- Robert Katz, Kansas State University, Manhattan, Kans.
- Harry H. Kemp, Logan High School, Utah
- Ashok Khosla, Harvard University
- John Kemeny, National Film Board of Canada, Montreal
- Merritt E. Kimball, Capuchino High School, San Bruno, Calif.
- Walter D. Knight, University of California, Berkeley
- Donald Kreuter, Brooklyn Technical High School, N.Y.
- Karol A. Kunysz, Laguna Beach High School, Calif.
- Douglas M. Lapp, Harvard University
- Leo Lovatelli, University of Illinois, Urbana
- Joan Laws, American Academy of Arts and Sciences, Boston
- Alfred Leitner, Michigan State University, East Lansing
- Robert B. Lillich, Solon High School, Ohio
- James Lindblad, Lowell High School, Whittier, Calif.
- Noel C. Little, Bowdoin College, Brunswick, Me.
- Arthur L. Loeb, Ledgemont Laboratory, Lexington, Mass.
- Richard T. Mara, Gettysburg College, Pa.
- John McClain, University of Beirut, Lebanon
- William K. Mehlbach, Wheat Ridge High School, Colo.
- Priya N. Mehta, Harvard University
- Glen Mervyn, West Vancouver Secondary School, B.C., Canada
- Franklin Miller, Jr., Kenyon College, Gambier, Ohio
- Jack C. Miller, Pomona College, Claremont, Calif.
- Kent D. Miller, Claremont High School, Calif.
- James A. Minstrel, Mercer Island High School, Washington
- James F. Moore, Canton High School, Mass.
- Robert H. Mosteller, Princeton High School, Cincinnati, Ohio
- William Naison, Jamaica High School, N.Y.
- Henry Nelson, Berkeley High School, Calif.
- Joseph D. Novak, Purdue University, Lafayette, Ind.
- Thorir Olafsson, Menntaskolinn Ad, Laugarvatn, Iceland
- Jay Orear, Cornell University, Ithaca, N.Y.
- Paul O'Toole, Dorchester High School, Mass.
- Costas Papaliolios, Harvard University
- Jacques Parent, National Film Board of Canada, Montreal
- Eugene A. Piatten, San Diego High School, Calif.
- L. Eugene Poorman, University High School, Bloomington, Ind.
- Cloria Poulos, Harvard University
- Herbert Priestley, Knox College, Galesburg, Ill.
- Edward M. Purcell, Harvard University
- Gerald M. Rees, Ann Arbor High School, Mich.
- James M. Reid, J. W. Sexton High School, Lansing, Mich.
- Robert Resnick, Rensselaer Polytechnic Institute, Troy, N.Y.
- Paul I. Richards, Technical Operations, Inc., Burlington, Mass.
- John Rigdon, Eastern Nazarene College, Quincy, Mass.
- Thomas J. Ritzinger, Rice Lake High School, Wis.
- Nickerson Rogers, The Loomis School, Windsor, Conn.
- Sidney Rosen, University of Illinois, Urbana
- John I. Rosenbaum, Livermore High School, Calif.
- William Rosenfeld, Smith College, Northampton, Mass.
- Arthur Rothman, State University of New York, Buffalo
- Daniel Rufolo, Claremont High School, San Diego, Calif.
- Bernhard A. Sachs, Brooklyn Technical High School, N.Y.
- Morton L. Schagrin, Denison University, Granville, Ohio
- Rudolph Schiller, Valley High School, Las Vegas, Nev.
- Myron O. Schneiderwent, Interlochen Arts Academy, Mich.
- Guenther Schwarz, Florida State University, Tallahassee
- Sherman D. Sheppard, Oak Ridge High School, Tenn.
- William E. Shortall, Lansdowne High School, Baltimore, Md.
- Devon Showley, Cypress Junior College, Calif.
- William Shurcliff, Cambridge Electron Accelerator, Mass.
- George I. Squibb, Harvard University
- Sister M. Suzanne Kelley, O.S.B., Monte Casino High School, Tulsa, Okla.
- Sister Mary Christine Martens, Convent of the Visitation, St. Paul, Minn.
- Sister M. Helen St. Paul, O.S.F., The Catholic High School of Baltimore, Md.
- M. Daniel Smith, Earlham College, Richmond, Ind.
- Sam Standing, Santa Fe High School, Santa Fe Springs, Calif.
- Albert B. Stewart, Antioch College, Yellow Springs, Ohio
- Robert T. Sullivan, Burnt Hills-Ballston Lake Central School, N.Y.
- Lovd S. Swerson, University of Houston, Texas
- Thomas E. Thorpe, West High School, Phoenix, Ariz.
- June Goodfield Toulmin, Nuffield Foundation, London, England
- Stephen E. Toulmin, Nuffield Foundation, London, England
- Emily H. Van Zee, Harvard University
- Ann Venable, Arthur D. Little, Inc., Cambridge, Mass.
- W. O. Viens, Nova High School, Fort Lauderdale, Fla.
- Herbert J. Walberg, Harvard University
- Eleanor Webster, Wellesley College, Mass.
- Wayne W. Welch, University of Wisconsin, Madison
- Richard Weller, Harvard University
- Arthur Western, Melbourne High School, Fla.
- Haven Whiteside, University of Maryland, College Park
- R. Brady Williamson, Massachusetts Institute of Technology, Cambridge
- Stephen S. Winter, State University of New York, Buffalo



welcome to the Study of physics. This volume, more of a student's guide than a text of the usual kind, is part of a whole group of materials that includes a student handbook, laboratory equipment, films, programmed instruction, reader, transparencies, and so forth. Harvard Project Physics has designed the materials to work together. They have all been tested in classes that supplied results to the Project for use in revisions of earlier versions.

The Project Physics course is the work of about 200 scientists, scholars, and teachers from all parts of the country, responding to a call by the National Science Foundation in 1963 to prepare a new introductory physics course for nationwide use. Harvard Project Physics was established in 1964, on the basis of a two-year feasibility study supported by the Carnegie Corporation. On the previous pages are the names of our colleagues who helped during the last six years in what became an extensive national curricular development program. Some of them worked on a full-time basis for several years; others were part-time or occasional consultants, contributing to some aspect of the whole course but all were valued and dedicated collaborators who richly earned the gratitude of everyone who cares about science and the improvement of science teaching.

Harvard Project Physics has received financial support from the Carnegie Corporation of New York, the Ford Foundation, the National Science Foundation, the Alfred P. Sloan Foundation, the United States Office of Education and Harvard University. In addition, the Project has had the essential support of several hundred participating schools throughout the United States and Canada, who used and tested the course as it went through several successive annual revisions.

The last and largest cycle of testing of all materials is now completed; the final version of the Project Physics course will be published in 1970 by Holt, Rinehart and Winston, Inc., and will incorporate the final revisions and improvements as necessary. To this end we invite our students and instructors to write to us if in practice they too discern ways of improving the course materials.

The Directors  
Harvard Project Physics

Prologue	1
Chapter 13 Light	5
Propagation of light	6
Reflection and refraction	10
Interference and diffraction	13
Color	17
Why is the sky blue?	21
Polarization	23
The other	26
Chapter 14 Electric and Magnetic Fields	35
The curious properties of lodestone and amber	35
Gilbert's De Magnete	37
Electric charges and electric force	39
Force and field	44
The smallest charge	52
Early research with electric charges	54
Electric currents	56
Electric potential difference	57
Electric potential difference and current	60
Electric potential difference and power	60
Currents act on magnets	61
Currents act on currents	64
Magnetic fields and moving charges	65
Chapter 15 Faraday and the Electrical Age	74
The problem: getting energy from one place to another	75
Clue to the solution: electromagnetism	77
Faraday's early work on electricity and lines of force	76
The discovery of electromagnetic induction	79
Generating electricity from magnetism: the dynamo	81
The electric motor	86
The electric light bulb	89
Ac versus dc and the Niagara Falls power plant	92
Electricity and society	100
Chapter 16 Electromagnetic Radiation	107
Maxwell's formulation of the principle of electromagnetism	108
The propagation of electromagnetic waves	112
Hertz's experiments	116
The electromagnetic spectrum	120
Maxwell: intellectual characteristics and attitudes	126
What about the ether?	129
Epilogue	136
Index	138
Brief Answers to Study Guide	141
Answers to End of Section Questions	145

*"In Nature's infinite book of secrecy  
A little can I read."  
SHAKESPEARE, Antony and Cleopatra*

**Prologue** The conviction that the world, and all that is in it, consists of matter in motion drove scientists to search for mechanical models that could account for light and electromagnetism. This search, what was discovered and the changes these discoveries initiated in science, in technology, and in society form the subject of this volume. In this prologue we sketch the development of some of these models and briefly indicate the effect of these developments on our present ideas of the physical world.

During the seventeenth and eighteenth centuries there were two competing models for light, one depicting light as particles, the other depicting light as waves. Both models were constructed with the Newtonian components of matter and motion. The wave model won general acceptance, not because it fitted the Newtonian scheme better than the particle model, but because it was better able to account for newly discovered optical effects. Chapter 13 tells the story of the triumph of the wave theory of light in the first half of the nineteenth century. The wave theory maintained its supremacy until the early part of the twentieth century when it was found that neither waves nor particles were sufficient to account for the behavior of light.

As experiments established that electric and magnetic forces have some characteristics in common with gravitational forces, theories of electricity and magnetism were developed which were modeled on Newton's treatment of gravitation. The assumption that there are forces between electrified and magnetized bodies which vary inversely with the square of the distance was found to account for many observations. The drafters of these theories assumed that bodies can exert forces over a distance without the necessity for one body to touch another.

Although action-at-a-distance theories were remarkably successful in providing a quantitative explanation for some aspects of electromagnetism, these theories did not at the time provide a comprehensive explanation. Instead, the means of description that became widely accepted by the end of the nineteenth century, and that is now generally believed to be the best way to discuss all physical forces, is based on the idea of fields, an idea that we introduce in Chapter 14 and develop further in the last chapter of the unit.

Many scientists felt that action-at-a-distance theories, however accurate in prediction, failed to give a satisfactory physical explanation for how one body exerts a force on another. Newton himself was reluctant to assume that one body can act on another through empty space. In a letter to



It was inconceivable to many scientists that one body could directly affect another across empty space. They devised a variety of schemes to fill the space in between with something that would transmit the effect first with material "ether," -- later with mathematical "fields." Some of these schemes are illustrated on the opposite page: Descartes, 17th century (bottom left), Euler, 18th century (top), Maxwell, 19th century (middle right). Above is a drawing copied from The New York Times (1967) representing the earth's magnetic field, which is distorted by a flow of charged particles from the sun.

This letter is reproduced exactly as Newton wrote it.

Richard Bentley he wrote:

This is unconceivable to me that inanimate brute matter should (without the mediation of something else which is not material) operate upon & affect other matter without mutual contact; ... And this is one reason why I desired you would not ascribe innate gravity to me. That gravity should be innate inherent & essential to matter so yt one body may act upon another at a distance thro' a vacuum without the mediation of any thing else by which through wch their action or force may be conveyed from one point to another is to me so great an absurdity that I believe no man who has in philosophical matters any competent faculty of thinking can ever fall into it.

Some seventeenth-century scientists, less cautious in their published speculations than Newton, proposed that objects are surrounded by atmospheres that extend to the most distant regions and serve to transmit gravitational, electrical and magnetic forces from one body to another. The atmospheres proposed at this time were not made a part of a quantitative theory. In the nineteenth century, when the idea of an all-pervading atmosphere was revived, numerous attempts were made to develop mathematically the properties of a medium that would transmit the waves of light. The name "luminiferous ether" was given to this hypothetical "light-bearing" substance.

The rapid discovery of new electrical and magnetic effects in the first half of the nineteenth century acted as a strong stimulus to model building. Michael Faraday (1791-1867), who made many of the important discoveries, developed a model that assigned lines of force to the space surrounding electrified and magnetized bodies. Faraday showed how these lines of force could be used to account for many electromagnetic effects.

William Thomson (Lord Kelvin) was a Scottish mathematical physicist who contributed to the fields of electricity, mechanics and thermodynamics and to such practical developments as an improved ship's compass and the first Atlantic cable. The Kelvin scale of absolute temperature is named for him.

In a paper he wrote at age 17, William Thomson (1824-1907) showed how the equations used to formulate and solve a problem in electrostatics could also be used to solve a problem in the flow of heat. At that time electrostatics was most simply and effectively treated by considering that electrical forces can act at a distance, while the flow of heat was generally held to result from the action of parts that touch. With this paper Thomson showed that the same mathematical formulation could be used for theories based on completely different physical assumptions. Perhaps, then, it was more important to find a correct set of equations than it was to choose a particular mechanical model.

James Clerk Maxwell (1831-1879), inspired by Faraday's physical models and by Thomson's mathematical demonstrations, undertook the task of developing a mathematical theory of electromagnetism. From the assumption of an imaginary ether

ERIC  
Full Text Provided by ERIC

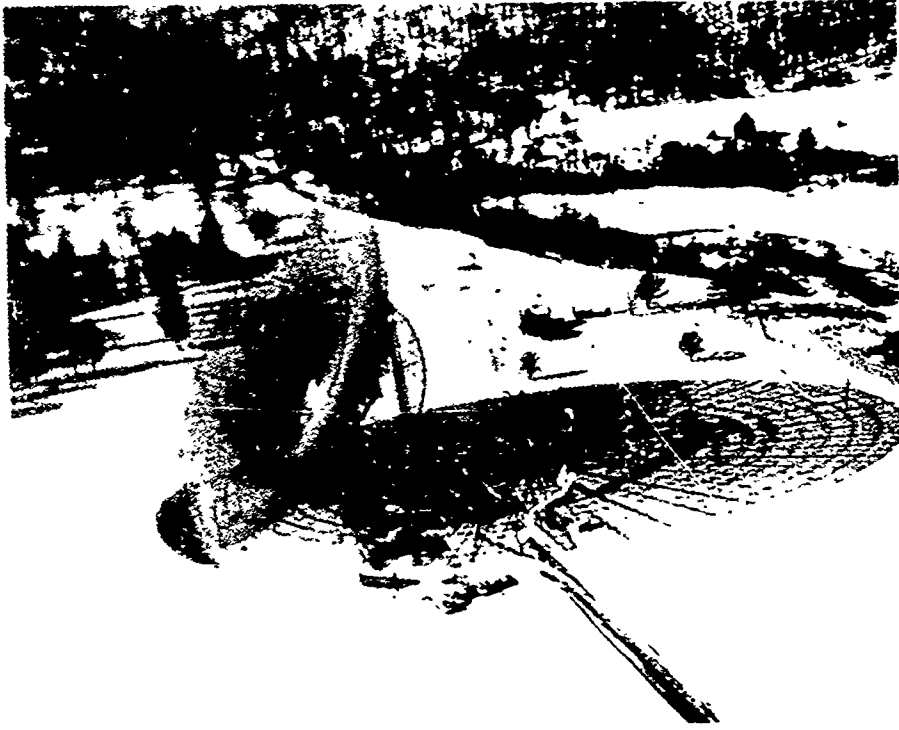

Chapter 13 Light

Section		Page
13 1	Introduction	5
13 2	Propagation of light	6
13 3	Reflection and refraction	10
13 4	Interference and diffraction	13
13 5	Color	17
13 6	Why is the sky blue?	21
13 7	Polarization	23
13.8	The ether	26



**13.1 Introduction.** What is light? At first glance, this may seem to be a rather trivial question. After all, there is hardly anything that is more familiar to us. We see by means of light. We also live by light, for without it there would be no photosynthesis, and photosynthesis is the basic source of energy for most forms of life on earth. Light is the messenger which brings us most of our information about the world around us, both on the earth and out to the most distant reaches of space. Because our world is largely defined by light, we have always been fascinated by its behavior. From the beginning of recorded history men have asked themselves questions about light. How fast does it travel? How does it manage to travel across empty space? What is color?

To the physicist, light is a form of energy. He can describe light by measurable values of wavelengths and frequencies and intensity of the beam. To him, as to all people, light also means brightness and shade, the beauty of summer flowers and fall foliage, of red-gold sunsets and of the canvases painted by master artists. These are really two ways of looking at light: one way is to regard its measurable aspects—which has been enormously fruitful in physics and in technology. The other is to ask about the emotional responses in us when we view the production of light in nature or art. Still another way of considering light is in terms of the biophysical process of vision. The physical, biophysical, and psychological aspects of light are closely related.

Because these aspects of light are not easily separated, problems raised about light in the early history of science were more subtle and more elusive than those associated with most other aspects of our physical experience. Early ideas on its nature were confused by a failure to distinguish between light and vision. This confusion is still evident in young children. When playing hide-and-go-seek, some of them "hide" by covering their eyes with their hands; apparently they think that they cannot be seen when they cannot see. This almost instinctive association of vision with light persists into the language of the adult world. We talk about the sun "peeping out of the clouds" or the stars "looking down."

Some of the Greek philosophers believed that light travels in straight lines at high speed, and that it contains particles which stimulate the sense of vision when they enter the eye. For centuries after the Greek era during which limited attention was paid to the nature of light, the particle model persisted. However, around 1500 Leonardo da Vinci, noting a similarity between sound echoes and the reflection of light,

*Summary 13.1  
What is light? After some remarks about how the physicist would try to answer this question, we pose the question more precisely: "How appropriate is a wave model in explaining the observed properties of light?"*



Behold the Light emitted from the Sun,

What more familiar, and what more unknown,

While by its spreading Radiance it reveals

All Nature's Face, at still it self conceals ...

How soon th'Effulgent Emanations fly

Thro' the blue Gulph of a cerposing Sky:

How soon their Lustre all the Region fills,

Smiles on the Vallies, and adorns the Hill's!

Millions of Miles, so rapid is their Race,

To cheer the Earth, they in few Moments pass.

Amazing Progress! At its utmost Stretch,

What human Mind can this swift Motion reach?

Richard Blackmore, Creation II, 1715, 386-399.



speculated that light, like sound, might have a wave character.

A decided difference of opinion emerged among scientists of the seventeenth century, about the nature of light. Some, including Newton, favored a model largely based on the idea of light as a stream of particles. Others, including Huygens, supported a wave model. By the late nineteenth century, however, there appeared to be overwhelming evidence that the observed characteristics of light could be explained by assuming that it had the nature of a wave motion; that is, by assuming a wave model. In this chapter we shall look at the question "How appropriate is a wave model in explaining the observed behavior of light?" That is, we shall take the wave model as a hypothesis, and examine the evidence that supports it. We must bear in mind that any scientific model, hypothesis or theory has two chief functions—to explain what is known, and to make predictions that can be subjected to experimental test. We shall look at both of these aspects of the wave model. The result will be very curious. The wave model turns out to work splendidly for all the properties of light known before the twentieth century. But in Chapter 18 we will find that for some purposes we must adopt instead a particle model. Then in Chapter 20 we will combine both models, joining together two apparently opposite theories!

We have already mentioned that light travels in straight lines and at high speed. Our daily use of mirrors convinced us that light can also be reflected. There are other characteristics of light—for example, it can be refracted, and it shows the phenomena of interference and diffraction. All of these properties you have studied earlier, when looking at the behavior of waves in Chapter 12. It would therefore be well for you to refresh your memory about the basic ideas of that chapter before going on to the study of light. We shall, however, look at some additional phenomena of light—dispersion, polarization and scattering—which so far we have considered either not at all or in minimum detail in the earlier discussion. As we shall see, these also fit into our wave model, and in fact constitute strong experimental support for it. Before going on to a discussion of these various characteristics of light's behavior and how they provide evidence in support of our hypothesis of a wave model for light, we shall first consider the propagation of light and two characteristics—reflection and refraction—which can be explained by both a corpuscular (particle) model and a wave model.

13.2 Propagation of light. There is ample evidence that light travels in straight lines. The fact that one cannot see

*A: Looking into the eye*

*Summary 13.2*

*1 Beams of light travel in straight lines.*

*2 The first estimate of the speed of light was made by Huygens in the seventeenth century, using astronomical data*

Light Beams Travel in Straight Lines.

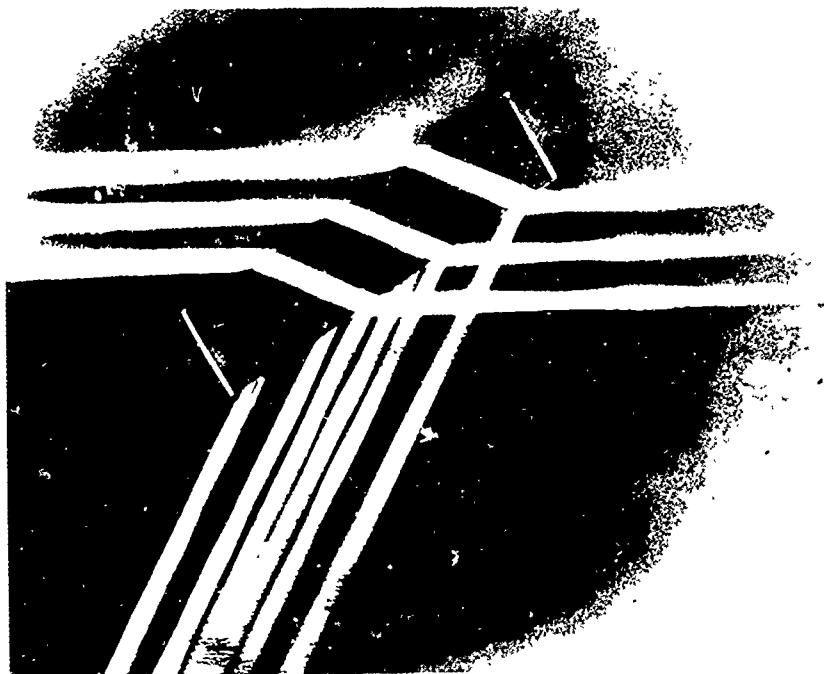

7.50 speed of light

"Camera obscura" is a Latin phrase meaning "dark chamber."

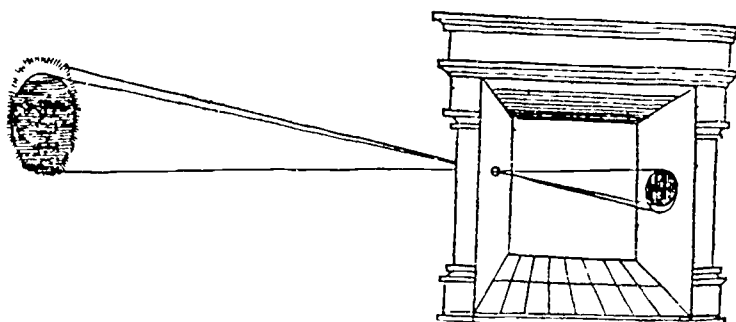

First published illustration of a camera obscura: observing a solar eclipse in January 1544, from a book by the Dutch physician and mathematician Gemma Frisius.

An attempt to produce a "ray" of light. To make the pictures at the right, a parallel beam of red light was directed through increasingly narrow slits to a photographic plate. The slit widths, from left to right, were 1.5 mm, 0.7 mm, 0.4 mm, 0.2 mm and 0.1 mm. The results are similar to those shown for water ripples on p. 133 of Unit 3 (Fig. 12.23). (Of course the narrower the slit the less the light that gets through. This was compensated for by longer exposures.)

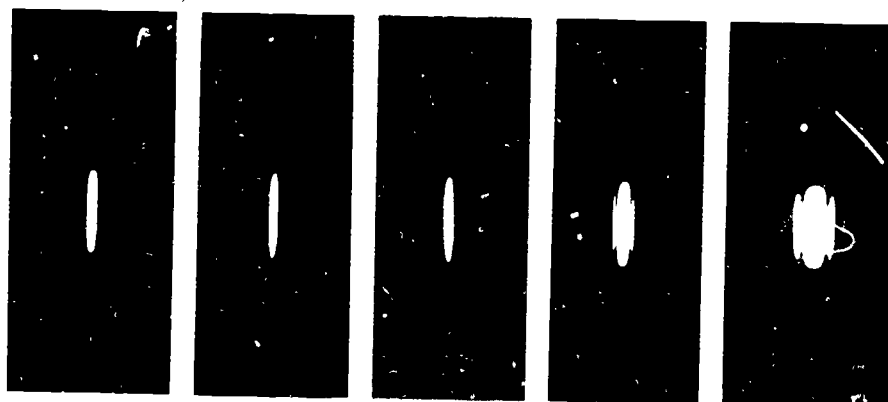

Given that light seems to travel in straight lines, can we tell how fast it goes? Galileo discussed this problem in his Dialogues Concerning Two New Sciences. He points out that

"around the corner" of an obstacle is one obvious example. The outline of a shadow cast by the sun is but one example of the sharply defined shadows cast by a large but very distant source. Similarly, sharp shadows are cast by a closer source of small dimensions. The distant sun or the nearby small source are approximately point sources of light; it is from such point sources that we get sharp shadows. Before the invention of the modern camera with its lens system, a light-tight box with a pinhole in the center of one face was widely used. As the camera obscura, it was highly popular in the Middle Ages. Leonardo da Vinci probably used it as an aid in his sketching. In one of his manuscripts he says that "a small aperture in a window shutter projects on the inner wall of the room an image of the bodies which are beyond the aperture," and he includes a sketch to show how the straight-line propagation of light explains the formation of an image.

It is often convenient to use a straight line to represent the direction in which light travels. The convenient pictorial device, an infinitely thin ray of light, is useful for thinking about light but it does not correspond to anything that actually exists. A light beam emerging from a good-sized hole in a screen is as wide as the hole. You might expect that if we made the hole extremely small we would get a very narrow beam of light—ultimately, just a ray. But we don't! Diffraction effects (such as you have already observed for water and sound waves) appear when the beam of light passes through a small hole. So a ray of light, pictorially useful, cannot be produced in practice. But we can still use the idea to represent the direction in which a train of parallel waves is traveling.

everyday experiences might lead us to conclude that the propagation of light is instantaneous. But these experiences, when analyzed more closely, really show only that light travels much faster than sound. For example, "when we see a piece of artillery fired, at a great distance, the flash reaches our eyes without lapse of time; but the sound reaches the ear only after a noticeable interval." But how do we really know that the light moved "without lapse of time" unless we have some accurate way of measuring the lapse of time?

A: *Miscellaneous light activities*

Galileo then described an experiment by which the speed of light might be measured by two persons on distant hills flashing lanterns. (This experiment is to be analyzed in §3 13.2). He concluded that the speed of light is probably not infinite, but was not able to estimate a definite value for it.

The first definite evidence that light moves at a finite speed was found by a Danish astronomer, Ole Romer. In September 1676, Romer announced to the Academy of Sciences in Paris that the eclipse of a satellite of Jupiter, which was expected to occur at 45 seconds after 5:25 a.m. on the ninth of November, would be exactly ten minutes late. On November 9, 1676, astronomers at the Royal Observatory in Paris, though skeptical of Romer's mysterious prediction, made careful observations of the eclipse and reported that it occurred at 45 seconds after 5:35 a.m., just as Romer had predicted.

*See note on "Romer" in Articles section*

Two weeks later, Romer revealed the theoretical basis of his prediction to the baffled astronomers at the Academy of Sciences. He explained that the delay in the eclipse was simply due to the fact that light from Jupiter takes a longer or shorter time to reach the earth, depending on the relative positions of Jupiter and the earth in their orbits. In fact, he declared that it takes 22 minutes for light to cross the earth's orbit.

Shortly thereafter, the Dutch physicist Christiaan Huygens used Romer's data to make the first calculation of the speed of light. He combined the value of 22 minutes for light to cross the earth's orbit with his own estimate of the diameter of the earth's orbit. (This distance could be estimated for the first time in the seventeenth century, as a result of the advances in astronomy described in Unit 2.) Huygens obtained a value which, in modern units, is about  $2 \times 10^8$  meters per second. This is about two-thirds of the presently accepted value (see below). The discrepancy is mainly due to the fact that light actually takes only about 16 minutes to cross the earth's orbit. As often happens, modern historians of science

[Römer] the sage, who, studious  
of the skies,  
Heedful explores these late-  
discovered worlds,  
By this observed, the rapid  
progress finds  
Of light itself, how swift the  
headlong ray  
Shoots from the Sun's height  
through unbounded space,  
At once enlightening air, and  
Earth, and Heaven.

David Mallett, The Excursion,  
eighteenth century.

have cast some doubt on the exactness of Romer's calculation of the time interval and on the observation of the time of the eclipse. Nevertheless, the importance of Romer's work was not so much that it led to a particular value of the speed of light, but rather that it established that the propagation of light is not instantaneous but takes a finite time.

See the article "Velocity of Light" in Project Physics, Reader 4.

The speed of light has been measured in many different ways since the seventeenth century. Since the speed is very high, it is necessary to use either a very long distance or a very short time interval. The earlier methods were based on measurements of astronomical distances. In the nineteenth century, rotating slotted wheels and mirrors made it possible to measure very short time intervals so that distances of a few miles could be used. The development of electronic devices in the twentieth century allows measurement of even shorter time intervals, so that the speed of light is now known to an accuracy of better than 1 part in  $10^7$ . Because of the importance of the speed of light in modern physical theories, physicists are continuing to improve their methods of measurement even though this speed is already one of the most accurately known physical constants.

As of 1964, the most accurate measurements indicate that the speed of light in vacuum is 299,792,500 meters per second. The uncertainty of this value is less than 300 meters per second, or 0.0001%. The speed of light is usually represented by the symbol  $c$ , and for most purposes it is sufficient to use the approximate value  $c = 3 \cdot 10^8$  meters per second.

Why can't a beam of light be made increasingly narrow by passing it through narrower and narrower slits?

What reason did Romer have for thinking that the eclipse of a particular satellite of Jupiter would be observed later than expected?

What was the most important outcome of Romer's work?

**13.3 Reflection and refraction.** What happens when a ray of light traveling in one medium (say air) hits the boundary of another medium (say glass)? The answers to this question depend on whether we adopt a particle or a wave theory of light, and therefore give us a chance to test which theory is better.

We have already discussed reflection and refraction from the wave viewpoint in Chapter 12, so we need only recall the results obtained there.

1) A ray may be taken as the line drawn perpendicular to a wave's crest lines; a ray represents the direction in which a train of parallel waves is traveling.

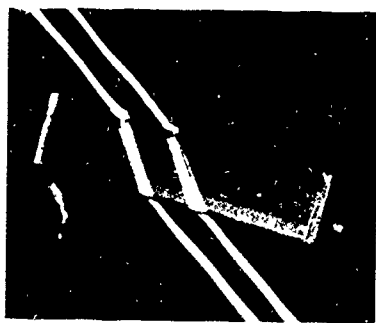

Two narrow beams of light, coming from the upper left, strike a block of glass. Can you account for the other effects?

Summary 13.3

1) Using the wave model, we can explain rays as lines perpendicular to crest-lines, the angle of incidence is equal to the angle of reflection, and when a wave goes into a denser medium, its wavelength and speed decrease, and the ray is bent toward the normal

2) In reflection, the angle of incidence ( $\theta_i$ ) is equal to the angle of reflection ( $\theta_r$ ).

3) Refraction involves a change of wavelength and speed of the wave as it goes into another medium. In particular, when the wavelength decreases, the speed decreases, and the ray is bent in a direction toward a line perpendicular to the boundary. This bending toward the perpendicular is observed when a ray of light goes from air to glass.

The incident, reflected and refracted rays are in a plane perpendicular to the surface.

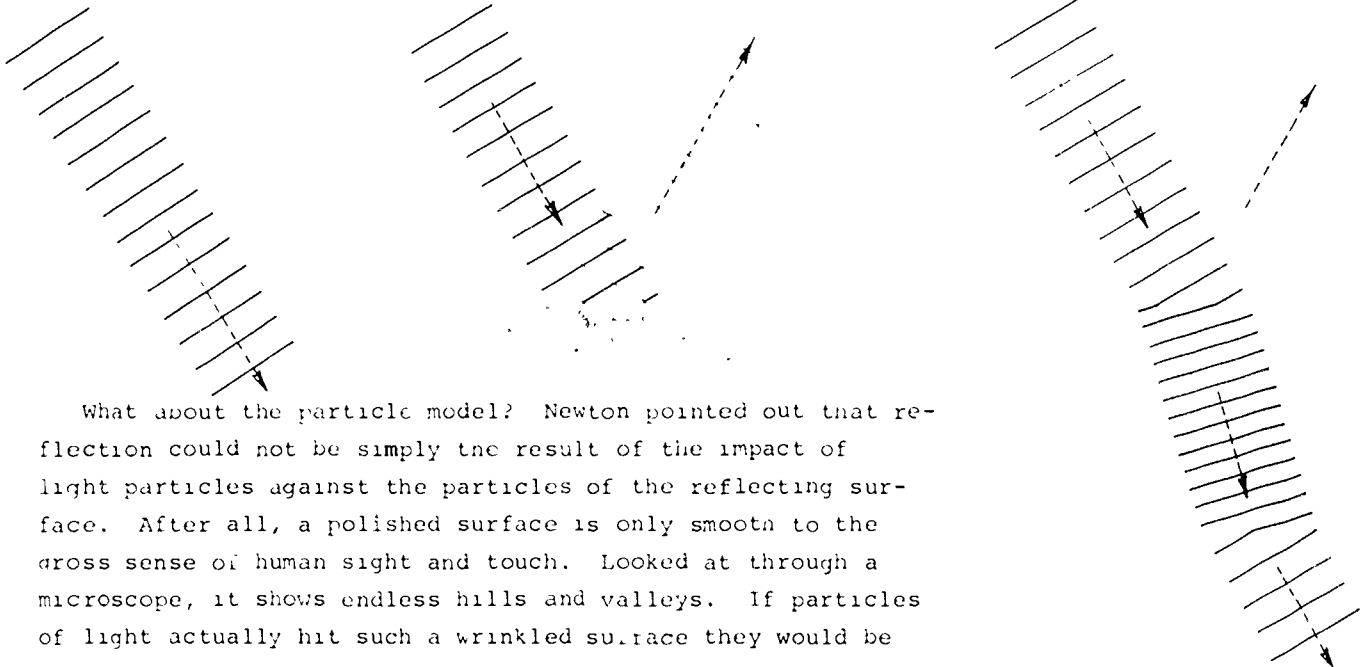

What about the particle model? Newton pointed out that reflection could not be simply the result of the impact of light particles against the particles of the reflecting surface. After all, a polished surface is only smooth to the gross sense of human sight and touch. Looked at through a microscope, it shows endless hills and valleys. If particles of light actually hit such a wrinkled surface they would be

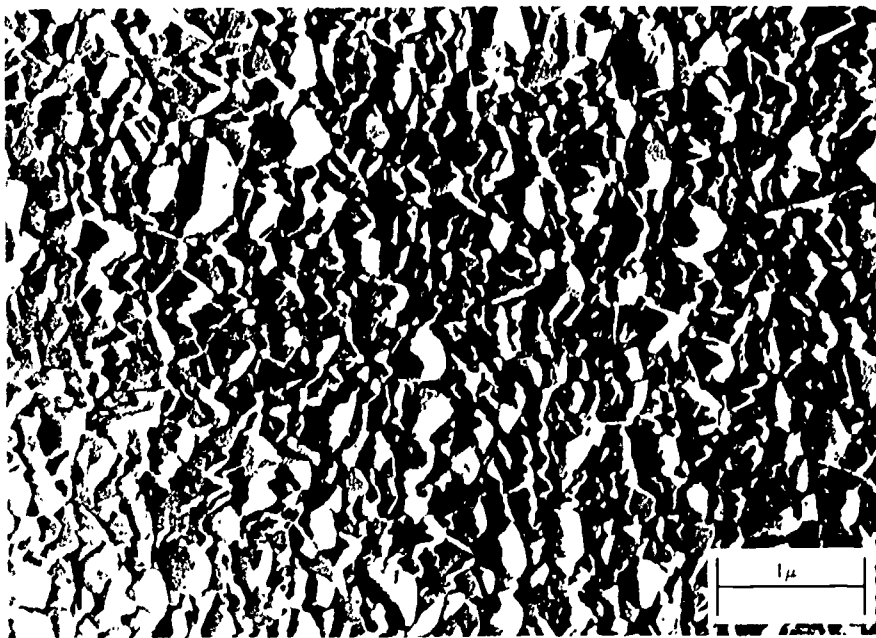

F31. Introduction to optics

The surface of a mirror as it appears on an electro micrograph. The surface is a 3- $\mu$  thick aluminum film prepared by vaporizing aluminum metal in a vacuum chamber. The magnification here is nearly 26,000. ( $\mu$  stands for micron; where  $1\mu = 10^{-6}$  meter)

scattered in all directions. To avoid this consequence, there must be (as Newton put it) "some feature of the body which is evenly diffused over its surface and by which it acts

A Matching index of refraction  
A Making an ice lens

2) If one were to use the particle model described by Newton, he could explain rays as lines along which particles move, equality of angles of incidence and reflection would follow from conservation of momentum and energy; when particles moved into a denser medium, their speed would increase and the ray be bent toward the normal to the boundary



3 The only difference between a wave and a particle model, so far, is that according to the wave model the speed decreases on going into a denser medium, whereas according to the particle model, it increases.

upon the ray without immediate contact." Obviously, this force or "power" was one which repelled the particles of light. A similar power, which attracted light particles instead of repelling them, could be used to explain refraction. As a particle of light approached a boundary of another medium, it would first have to penetrate the repulsive power; if it did that, it would then meet an attractive power in the medium which would pull it into the medium. Since the attractive force would be a vector with a component in the direction of the original motion of the ray, the light particle's speed would increase. If the ray were moving at an oblique angle to the boundary, its direction would change in the medium toward the line perpendicular to the boundary.

According to the particle model, therefore, we can make the following predictions about reflection and refraction.

1) A ray represents the direction in which the particles are moving.

2) In reflection, the angles of incidence and reflection are equal. This prediction can be derived from the Law of Conservation of Momentum (Chapter 9) applied to the interaction of the particles with the repulsive power of the medium. (See SG 13.12.)

3) Refraction involves a change of speed of the particles as they go into another medium. In particular, when an attractive power acts, the speed increases and the ray is bent into the medium.

Comparing these features of the particle model with the corresponding features of the wave model (above), we see that the only difference is in the relation between speed and refraction of a ray. When we observe that a ray is bent toward the perpendicular on going into another medium--as is the case for light going from air into water--then the particle theory predicts that light has a higher speed in the second medium, whereas the wave theory pred. that light has a lower speed.

You might think that it would be fairly easy to devise an experiment to determine which prediction is correct. All one has to do is measure the speed of light in water. However, in the late seventeenth and early eighteenth centuries, when the wave model was supported by Huygens and the particle model by Newton, no such experiment was possible. Remember that at that time the only available way of measuring the speed of light was an astronomical one. Not until the middle of the nineteenth century did Fizeau and Foucault measure the speed of light in water. The results agreed with the predictions of the wave model: the speed of light is lower in water than

Newton's particle model: repelling forces would cause reflection, attracting forces would cause refraction.

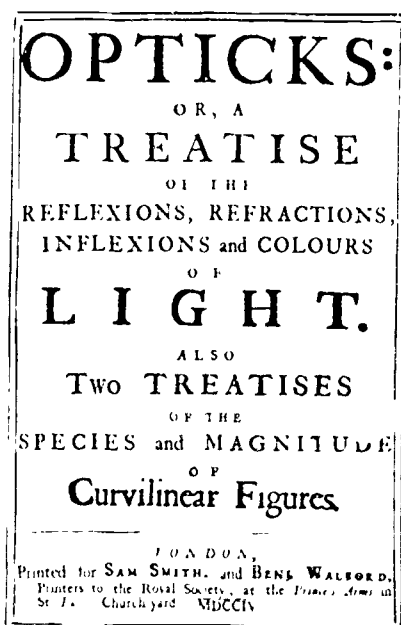

Title page from the first edition of Newton's *Opticks*, in which he described his particle model.



in air. But by the time these experiments were done, most physicists had already accepted the wave model for other reasons (see below). The Foucault-Fizeau experiments of 1850 were generally regarded as driving the last nail in the coffin of the particle theory.

1. What evidence showed conclusively that Newton's particle model of refraction was not valid for light?

2. If light has a wave nature, what changes take place in the speed, wavelength and frequency of light passing from air into water?

**13.4 Interference and diffraction.** From the time of Newton until the early years of the nineteenth century, the particle theory of light was favored by most physicists, largely because of the prestige of Newton. Early in the nineteenth century, however, the wave theory was revived by Thomas Young. He found, in experiments made between 1802 and 1804, that light shows the phenomenon of interference. Interference patterns have been discussed in Sec. 12.6 in connection with water waves. Such patterns could not easily be explained by the particle theory of light. Young's famous "double-slit experiment" provided convincing evidence that light has properties that can only be explained in terms of waves.

When a beam of light is split into two beams, and the split beams are then allowed to overlap, we find that the two wave trains interfere constructively in some places and destructively in others. To simplify the interpretation of the experiment, we will assume that the light has a single definite wavelength  $\lambda$ . (Young's original experiment was done with sunlight, which, as Newton had already shown, is a mixture of waves of different wavelengths.)

Thomas Young's original drawing showing interference effects in overlapping waves. Place the eye near the left edge and sight at a grazing angle along the diagram.

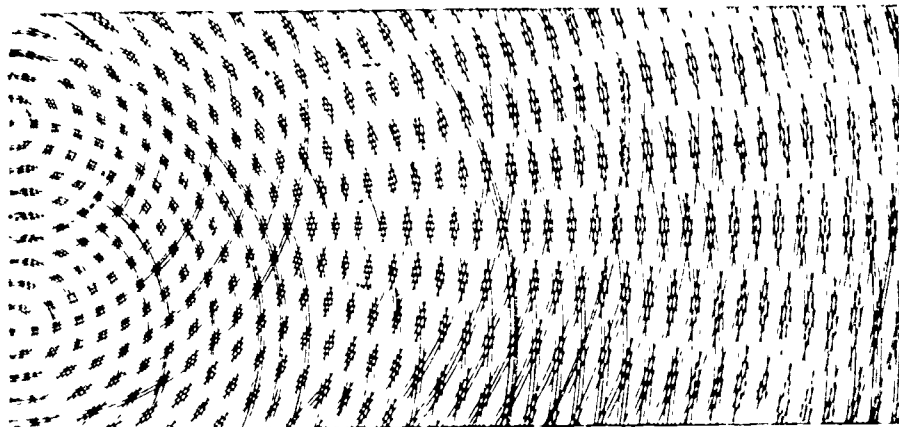

#### Summary 13.4

1. Young in his double-slit experiment showed that light exhibits the property of interference. He could also calculate the wavelength of light from his experiment

#### E32\*. Young's experiment

Thomas Young (1773-1829) was an English linguist, physician and expert in many fields of science. At the age of fourteen he was familiar with Latin, Greek, Hebrew, Arabic, Persian, French and Italian, and later was one of the first successful workers at decoding Egyptian hieroglyphic inscriptions. He studied medicine in England, Scotland and Germany. While still in medical school he made original studies of the eye, and later developed the first version of what is now known as the three-color theory of vision. He also did research in physiology on the functions of the heart and arteries, and studied the human voice mechanism, through which he became interested in the physics of sound and sound waves.

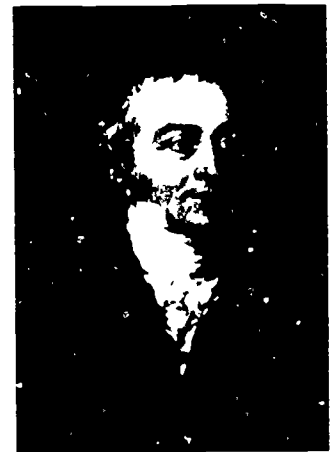

Young then turned to optics, and discovered that Newton's experiments with light could be explained in terms of waves. This conclusion was strongly attacked by some scientists in England because of the suggestion that Newton might be wrong.

See Young's paper "Experiments and Calculations Relative to Physical Optics" in Project Physics Reader 4.

When Fresnel, in France, proposed the wave theory in 1819, Poisson pointed out that it predicted the existence of a bright spot behind an illuminated disc. When this spot was actually found, it provided additional evidence for the wave theory.

13.4

A polaroid photograph taken through a Project Physics magnifier placed about 30 cm behind a pair of closely spaced slits. The slits were illuminated with a narrow but bright light source.



"breadth of the undulations" means the wavelength

Young allowed sunlight to fall on a pinhole punched in a screen. The emerging light from this "source" spread out by diffraction and fell on two pinholes punched near each other (at a distance  $d$  apart) in a second screen. Again, diffraction occurred and the hemispherical waves from each pinhole spread out into the space beyond the second screen. The interference pattern can then be seen where the light strikes a third screen. Where interference is constructive, we will get a bright region. Where interference is destructive, we will get a dark region.

By measuring the distance between successive bright lines in the interference pattern, we can calculate the wavelength of the light. The formulas needed for this calculation were derived in Sec. 12.6.

The fact that Young could actually find experimental values for the wavelength of light was additional evidence in favor of the wave theory. Here is his result:

From a comparison of various experiments, it appears that the breadth of the undulations constituting the extreme red light must be supposed to be, in air, about one 36 thousandth of an inch, and those of the extreme violet about one 60 thousandth, the means of the whole spectrum, with respect to the intensity of light, being one 45 thousandth.

When Young announced his new results supporting the wave theory of light, he took special pains to show that Newton himself had made several statements favoring the wave theory, even though he was generally considered a supporter of the particle theory. Nevertheless, Young was received with ridicule and even hostility by those British scientists to whom Newton's name was sacred. It was not until 1818, when the French physicist Augustin Fresnel proposed a mathematical wave theory of his own, that Young's research got the credit it deserved. Fresnel also had to submit his work for approval to a group of physicists who were already committed to the particle theory. The French physicists, however, thought that the particle theory could be proved correct by mathematics rather than by appealing to the authority of an English scientist (Newton). One of them, the brilliant mathematician Simon-Denis Poisson, took Fresnel's wave equations and showed that if these equations really did describe the behavior of light, a very peculiar thing ought to happen when a small disk is placed in a beam of light. A screen placed behind the disk should have a bright spot in the center of the shadow, because diffraction of the light waves around the edge of the disk should lead to constructive interference at the center. According to the particle theory, there could be no such

Henry Brougham, a British politician and amateur scientist, wrote in the Edinburgh Review in 1803: "this paper [by Young] contains nothing which deserves the name, either of experiment or discovery, and ... is in fact destitute of every species of merit ... We wish to raise our feeble voice against innovations, that can have no other effect than to check the progress of science, and renew all those wild phantoms of the imagination which Bacon and Newton put to flight from her temple."

bright spot. Since such a bright spot had never been observed, and furthermore the idea of a bright spot in the center of a shadow was absurd, Poisson announced gleefully to Fresnel that he had refuted the wave theory.

Fresnel accepted the challenge and arranged for this prediction to be tested by experiment immediately. The result: there was a bright spot in the center of the shadow, as predicted by Poisson, on the basis of Fresnel's wave theory.



Augustin Jean Fresnel (1788-1827) was an engineer of bridges and roads for the French government. In his spare time he carried out extensive experimental and theoretical work in optics. Fresnel developed a comprehensive wave model of light that successfully accounted for reflection, refraction, interference and polarization. He also designed a lens system for lighthouses that is still used today.

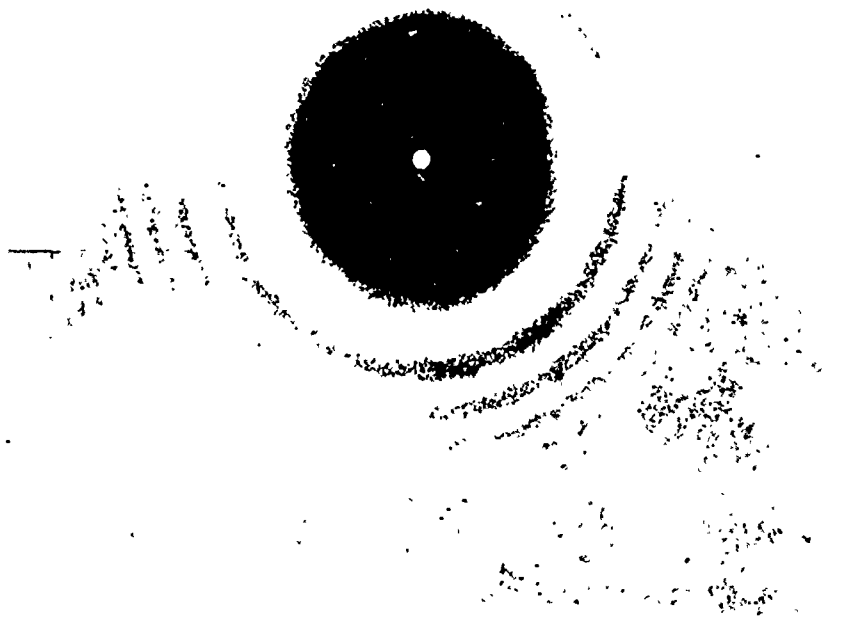

Diffraction pattern due to an opaque circular disc showing the Poisson bright spot in the center of the shadow. Note also the bright and dark fringes of constructive and destructive interference

As soon as the significance of the Young double-slit experiment and the Poisson bright spot was realized, support for the particle theory of light began to crumble away. By 1819 the validity of the wave model was generally accepted, and physicists began to concentrate on working out the mathematical consequences of this model and its application to all the different properties of light.

How did Young's experiments support the wave model of light?

In what way is diffraction involved in Young's experiments?

What remarkable phenomenon was shown by Poisson to be predictable on the basis of Fresnel's wave theory?



Loss of Detail Through Diffraction

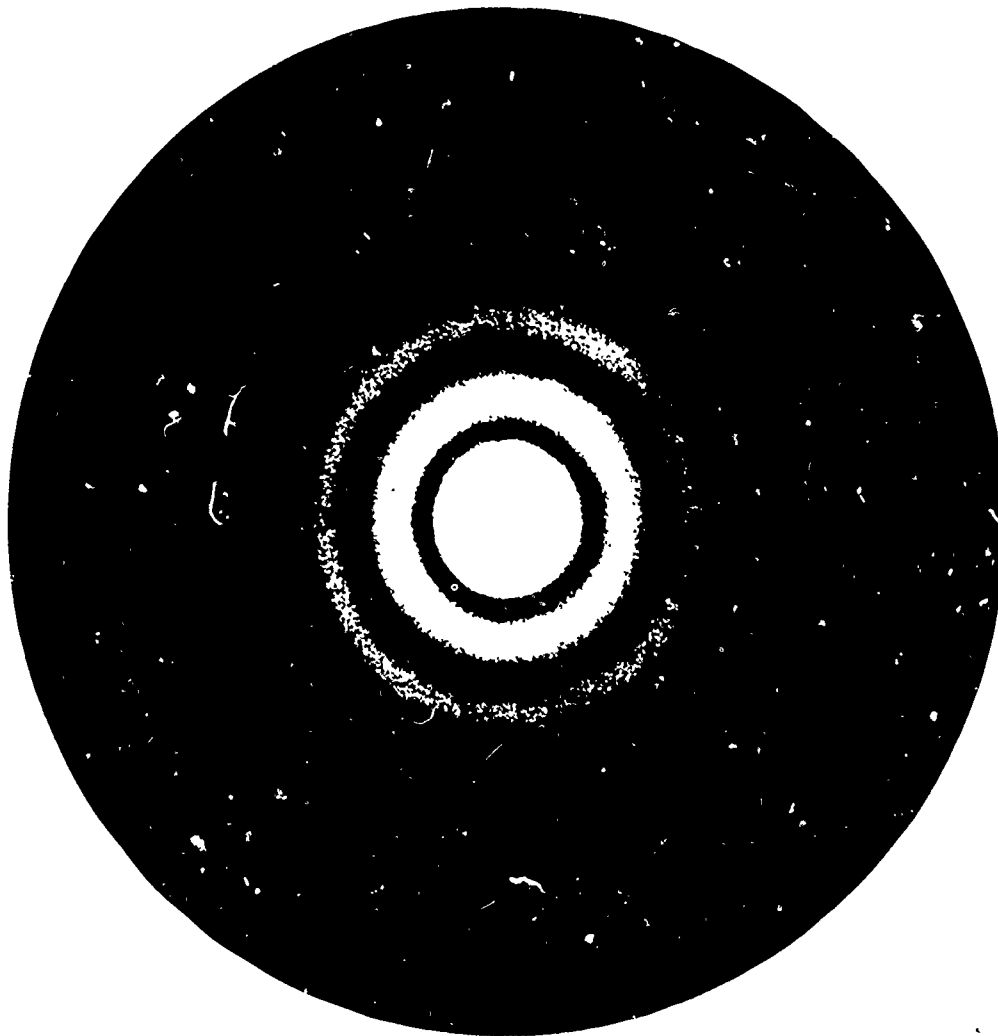

The photograph on the left shows the diffraction pattern of a point source of light. Diffraction by the camera lens opening has spread the light energy into a bright central disc surrounded by alternating dark and bright rings. The photographs below show an array of point sources, received through a progressively smaller and smaller hole. The array could represent a star cluster, surface detail on a planet, or living cells or simple specific points on some object.

We obtain most of the information about our environment by means of waves (light, sound, radio, etc.) which we receive through a hole; the pupil of the eye, the entrance to the ear, the aperture of an optical telescope or radio telescope, etc. The diffraction of the waves from the edges of the hole limits the detail of information that it is possible to receive. As the hole becomes smaller, the diffraction image of each point spreads out and begins overlapping the diffraction images of other points. When the diffraction patterns for the point overlap sufficiently it is impossible to distinguish between them.

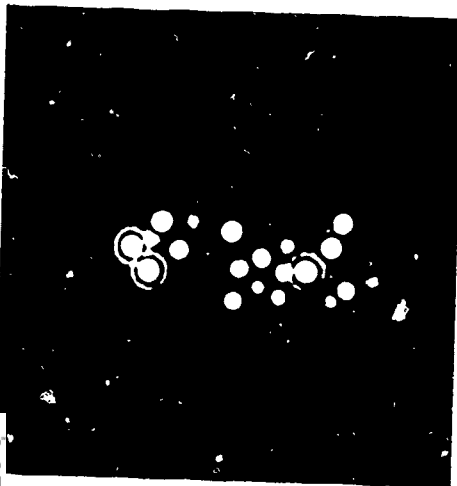

... for our  
... prehistoric  
... scientific theory of  
... until then,  
... had been ad-  
... who based their  
... Even today, a  
... from the

... fixing pigment can  
... of light. In early  
... the sun was "pure  
... color came from

... he was still a  
... to construct  
... some defects of  
... always surrounded  
... It was perhaps in  
... that he began

... a theory of  
... Transactions of The  
... first published scien-  
... scientific

... at which time I  
... glasses of other  
... triangular glass  
... phenomena of  
... darkened my cham-  
... window shuts, to  
... sun's light, I  
... that at night thereby  
... It was at first a  
... and intense

... the circular open-  
... the opposite wall  
... violet at one  
... gradation of  
... colors, Newton in-

... the colors come,  
... patch rather  
... Newton passed the  
... glass, changed  
... placed the prism

### Summary 135

1 Newton showed that white light is made up of light of many colors. When these different colors of light are separated by passing light through a prism, they cannot be further separated, but can be recombined to form white light by appropriate use of another prism.

2 Newton explained that objects have definite colors because every object absorbs and reflects, in a particular way, the various colored rays that strike it.

3 Newton's theory of colors was attacked by Hooke, and later in the nineteenth century by Goethe, but it gained the admiration of many eighteenth century poets.

This might seem odd,  
but it is the extreme  
rays which are being  
illustrated.

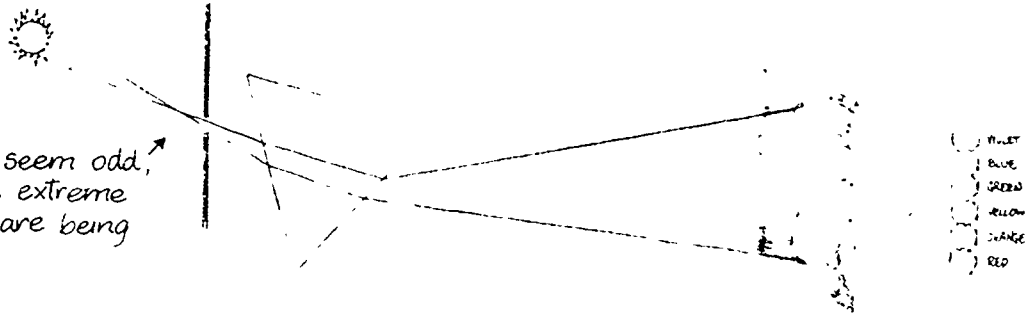

This drawing is similar to Newton's diagram of the refraction of white light by a prism. Instead of the image of the sun being circular, it was an oblong patch of colored light having straight parallel sides and semi-circular and rather fuzzy ends.

outside the window. But he found that none of these changes in conditions had any effect on the spectrum. To test whether some unevenness or irregularity in the colors produced the spectrum, he passed the colored rays from one prism through a second prism turned upside down.

If some irregularity in the glass was responsible for spreading out the beam of light, then passing this beam through the second prism should spread it out even more. Instead, the second prism, when properly placed, served to

bring the colors back together to form a spot of white light, as if the light had not passed through either prism.

By such a process of elimination, Newton convinced himself of a belief that he probably had held from the beginning: white light is composed of colors. It is not the prism that manufactures the colors; they were there all the time, but mixed up so that they could not be distinguished. When white light passes through a prism, each of the component colors is refracted at a different angle, so that the beam is spread into a spectrum.

As a further test of his hypothesis, Newton cut a small hole in a screen on which a spectrum was projected, so that light of a single color could be separated out and passed through another prism. He found that the second prism had no further effect on this single-color beam, aside from refracting it again. Once the first prism had done its job of separating out the colored components of white light, the second prism could not change the color of the components.

Summarizing his conclusions, Newton wrote:

Colors are not Qualifications of Light derived from Refraction or Reflection of natural Bodies (as 'tis generally believed) but Original and Connate Properties, which in divers Rays are divers. Some Rays are disposed to exhibit a Red Colour and no other; some a Yellow and no other, some a Green and no

A: Color vision by contrast

"Glass sticks are manufactured, either fluted or bulging with many corners like a club. If one of these sticks is placed obliquely in the path of the sun's rays it sends back the color which is wont to be seen in the rainbow ...." SENECA, second century A D

other, and so of the rest. Nor are there only Rays proper and particular to the more Eminent Colours, but even to all their intermediate gradations.

Apparent colors of objects. So far Newton had discussed only the colors of rays of light, but in a later section of his paper he raised the important question: why do objects appear to have certain colors? Why is the sky blue, the grass green, a paint-pigment yellow or red? Newton proposed a very simple answer:

That the Colours of all Natural Bodies have no other Origin than this, that they...Reflect one sort of Light in greater plenty than another.

In other words, a red pigment looks red to us because when white sunlight falls on it, the pigment absorbs most of the rays of other colors of the spectrum and reflects mainly the red to our eyes.

According to Newton's theory, color is not an inherent property of an object itself, but depends on how the object reflects and absorbs the various colored rays that strike it. Newton justified this hypothesis by pointing out that an object may appear to have a different color when a different kind of light shines on it. For example, if we shine blue light on a pigment that usually appears red, the pigment will reflect a little of the blue light, and since there is no red for it to reflect, it will appear blue. Newton wrote:

I have experimented in a dark Room, by illuminating those Bodies with un-compounded [pure] light of divers Colours. For by that means any Body may be made to appear of any Colour. They have therefore no appropriate Colour, but ever appear of the Colour of the Light cast upon them, but yet with this different, that they are most brisk and vivid in the Light of their own Day-light Colour.

Nowadays it is a familiar observation that clothing of certain colors appears different under artificial light and in sunlight.

Reactions to Newton's theory. Newton's theory of color met with violent opposition at first. Other British scientists, especially Robert Hooke, objected that postulating a different kind of light for each color was unnecessary. It would be simpler to assume that the different colors were produced from pure white light by some kind of modification. Hooke, for example, proposed a color theory based on the wave model of light: ordinarily, in white light, the wave front is perpendicular to the direction of motion. (See Sec. 12.5 for a definition of wave front.) Colors are produced, according to Hooke, when refraction by another medium twists the wave front so, that it is no longer perpendicular to the direction of motion.

Most colors are "body" colors, produced by selective absorption of light which penetrates a ways into the surface before being scattered back. This explains why the light transmitted by colored glass has the same color as the light reflected from it. Thin metallic films however, have "surface" color, resulting from selective regular reflection. Thus the transmitted light will be the complement of the reflected light. For example, the light transmitted by a thin film of gold is bluish-green, while that reflected is yellow.



Newton was aware of the fallacies in Hooke's theory, but he disliked controversy and did not attack it publicly. In fact, he waited until after Hooke's death in 1703 to publish his own book, Opticks (1704), in which he reviewed the properties of light and matter.

Although Newton's Principia was a much more important work from a scientific viewpoint, his Opticks had considerable influence on the literary world. English poets, celebrating the discoveries of their country's greatest scientist, were dimly aware of the significance of Newton's theory of gravity, but could not grasp the technical details of the geometric axioms and proofs of the Principia. But Newton's spectrum of colors provided ample opportunity for poetic fancy:

...First the flaming red,  
Springs vivid forth; the tawny orange next;  
And next delicious yellow; by whose side  
Fell the kind beams of all-refreshing green.  
Then the pure blue, that swells autumnal skies,  
Ethereal played; and then, of sadder hue,  
Emerged the deepened indigo, as when  
The heavy-skirted evening droops with frost;  
While the last gleamings of refracted light  
Died in the fainting violet away.  
[James Thomson, "To 'ne Memory of Sir Isaac Newton"  
(1727).]

Newton's ideas are also evident in a poem on the rainbow:

Meantime, refracted from yon eastern cloud,  
Bestriding earth, the grand ethereal bow  
Shoots up immense; and every hue unfolds,  
In fair proportion running from the red  
To where the violet fades into the sky.

Here, aw[e]ful Newton, the dissolving clouds  
Form, fronting on the sun, thy showery prism;  
And to the sage-instructed eye unfold  
The various twine of light, by thee disclosed  
From the white mingling blaze.  
[James Thomson, "Spring" (1728).]

Leaders of the nineteenth-century Romantic movement in literature, and the German "nature philosophers," did not think so highly of Newton's theory of color. The scientific procedure of dissecting and analyzing natural phenomena by experiments was distasteful to them. They preferred to speculate about the unifying principles of all natural forces, in order to grasp nature as a whole. The German philosopher Friedrich Schelling wrote in 1802:

Newton's Opticks is the greatest illustration of a whole structure of fallacies which, in all its parts, is founded on observation and experiment.

The foremost German poet, Goethe, spent many years trying to overthrow Newton's theory of colors, both by his own experi-

ments and by impassioned arguments. Goethe insisted on the purity of white light in its natural state. To the nineteenth-century physicists who were trying to use Newton's theory to explain newly-discovered color phenomena, he addressed the following poem:

May ye chop the light in pieces  
Till it hue on hue releases;  
May ye other pranks deliver,  
Polarize the tiny sliver  
Till the listener, overtaken,  
Feels his senses numbed and shaken—  
Nay, persuade us shall ye never  
Nor aside us shoulder ever.  
Steadfast was our dedication—  
We shall win the consummation.

"Do but despise reason and science  
The highest of man's powers,  
And thou art mine for sure!"  
GOETHE, words ascribed to the Devil,  
in *Faust*, I

Goethe rejected Newton's hypothesis that white light is a mixture of colors, and suggested that colors are produced by the interaction of white light and its opposite (or absence), darkness. Although Goethe's experiments on the perception of color were of some value to science, his theory of the physical nature of color did not survive the criticism of physicists. Newton's theory of color was firmly established, even in literature.

A: Poisson's spot

---

Q9 How did Newton show that white light was not "pure"?

Q10 Why could Newton be confident that green light was not itself composed of different colors of light?

Q11 How would Newton explain the color of a yellow coat?

Q12 Why was Newton's theory of color attacked by the nature philosophers?

---

6 Why is the sky blue? As Newton suggested, the apparent colors of natural objects depend on which color is predominantly reflected by the object. But in general, there is no simple way of predicting what colors an object will reflect. This is a difficult problem, involving the physical and chemical properties of the object. However, the color of the sky can be explained fairly simply if we introduce just one more fact about color: the relation between color and wavelength.

As Thomas Young found in his two-slit experiment (Sec. 13.4), different colors have different wavelengths. To specify the wavelength of light a special unit is used—the Ångström (Å), equal to  $10^{-10}$  meter. The range of the visible spectrum is from about 7000 Å for red light to about 4000 Å for violet light.

Newton found that rays of different colors are refracted by different amounts as they go through a glass prism. Since we know that waves are refracted when they go into a medium in which their speed is different, we can conclude that the

Summary 13.6

1 Different colors correspond to different wavelengths, ranging from 7000 Å for red to 4000 Å for violet.

2. When waves are scattered by relatively small obstacles, the longer the wavelength compared to the size of the object, the less the wave is scattered

3 Blue light is more strongly scattered by particles in the air than red light, therefore the sky appears blue.

The Ångström is named after Anders Jonas Ångström, a Swedish astronomer who, in 1862, used spectroscopic techniques to detect the presence of hydrogen in the sun.

speed of light in glass depends on its wavelength.

The scattering of waves by small obstacles also depends on wavelength. This fact can be demonstrated by experiments with waves in a ripple tank. As a general rule, the longer a wave is compared to the size of the obstacle, the less it is scattered by the obstacle. For light, calculations show that the amount of scattering decreases as the fourth power of the wavelength. This means that, since the wavelength of red light is almost twice the wavelength of blue light, the scattering of red light is only a little more than 1/16th as much as the scattering of blue light.

Now we can explain why the sky is blue. Light from the sun is scattered by air molecules and particles of dust or water vapor in the sky. Since these particles are usually much smaller than the wavelength of any kind of visible light, we can apply the general rule mentioned above, and conclude that light of shorter wavelengths (blue light) will be much more strongly scattered from the particles than light of longer wavelengths. The rays of longer wavelength (such as red) are not scattered very much, and they reach our eyes only when we look directly at the sun—but then they are mixed with all the other colors.

If the earth had no atmosphere, the sky would appear black and stars would be visible by day. In fact, starting at altitudes of about ten miles, where the atmosphere becomes quite thin, the sky does look black and stars can be seen during the day; this has been confirmed by reports and photographs brought back by astronauts.

When the air contains dust particles or water droplets as large as the wavelength of visible light (about  $10^{-6}$  meter), other colors than blue may be strongly scattered. For example, the quality of sky coloring changes with the water-vapor content of the atmosphere. On clear, dry days the sky is a much deeper blue than on clear days with high humidity. The intensely blue skies of Italy and Greece, which have been an inspiration to poets and painters for centuries, are a result of the drier air over these countries.

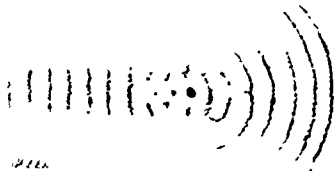

The scattering of different colors by a tiny obstacle is shown here for wavelengths representing red, green and blue light

An observer looking at a sunset is receiving primarily unscattered colors such as red; whereas if the observer looks overhead he will be receiving primarily scattered colors, the most dominant of which is blue.

Unusual events that change atmospheric conditions can produce strange color effects. On August 27, 1883, the volcano Krakatau (on an island between Sumatra and Java) exploded, making a hole 1,000 feet deep. The explosion was heard 2,500 miles away, and created ocean waves which killed 35,000 people. For months afterwards, as a layer of fine volcanic dust spread through the earth's atmosphere, the world witnessed a series of unusually beautiful sunrises and sunsets.

How does the scattering of light waves by tiny obstacles depend on the wavelength?

How would you explain the blue color of the sky?

**137 Polarization.** How could Newton, who made major discoveries in optics as well as in many other areas of physics, have refused to accept the wave model for light? Actually Newton did not reject the wave theory. He even suggested that different colored rays of light might have different wavelengths, and used this idea to explain the colors observed in thin plates and bubbles. But Newton could not accept the proposal of Hooke and Huygens that light is just like sound—that is, that light is nothing but a spherical pressure-wave propagated through a medium. Newton argued that light must also have some particle-like properties.

Newton mentioned two properties of light which, he thought, could not be explained without attributing particle properties to light. First, light is propagated in straight lines, whereas waves spread out in all directions and go around corners. The answer to this objection could not be given until early in the nineteenth century, when Young was able to measure the wavelength of light and found that it is much smaller than Newton had supposed. Even red light, which has the longest wavelength of any part of the visible spectrum, has a wavelength less than a thousandth of a millimeter. As long as light only shines on or through objects of ordinary size—a few centimeters in width, say—light will appear to travel in straight lines. Diffraction and scattering effects don't become evident until a wave strikes an object whose size is similar to its own wavelength.

Newton's second objection was based on the phenomenon of "polarization" of light. In 1669, the Danish scientist Erasmus Bartholinus discovered that crystals of Iceland spar had the curious property of splitting a ray of light into two rays. Thus small objects viewed through the crystal looked double. Huygens discussed the "double refraction" of light by Iceland spar in his treatise on light, but could not explain it satisfactorily with his

The following quotation is from a letter written by Vincent Van Gogh and refers to Arles in Southern France:

...nature here being so extraordinarily beautiful. Everywhere and all over the vault of heaven is a marvellous blue, and the sun sheds a radiance of pale sulphur, . . . it absorbs me so much that I let myself go, never thinking of a single rule.



**Iceland Spar Crystal  
Double Refraction**

**Iceland Spar Crystal  
Double Refraction**

wave model. However, he did find that one of the rays refracted by the crystal can be split again if it strikes another crystal of Iceland spar, but is not split for certain orientations of the second crystal.

To Newton it was clear that this behavior could only be explained by assuming that the ray is "polarized." That is, the ray has "sides" so that its properties depend on its orientation around its axis. This would be easy enough to understand if the ray is a stream of rectangular particles, but rather mysterious if light is a wave motion. As Newton pointed out,

For Pressions or Motions, propagated from a shining Body through a uniform Medium, must be on all sides alike; whereas by those Experiments it appears, that the Rays of Light have different Properties in their different sides.

[Newton, *Opticks*, Query 28.]

The answer to this second objection to the wave model for light also had to wait until the beginning of the nineteenth century. Before then, scientists had generally assumed that light waves, like sound waves, must be longitudinal. But around 1820, Young and Fresnel showed that light waves are probably transverse. Their successful explanation of polarization was the major piece of evidence for this conclusion.

In Chapter 12, we stated that in a transverse wave, the motion of the medium itself is always perpendicular to the direction of propagation of the wave. That does not mean that the motion of the medium is always in the same direction; it could be along any line in the plane perpendicular to the direction of propagation. However, if the motion of the medium is predominantly in one direction, for example, vertical, we say that the wave is polarized. (Thus a polarized wave is really the simplest kind of wave; an unpolarized wave is a more complicated thing, since it is a mixture of various motions.)

In 1808, Etienne Malus, a French scientist, noticed that when sunlight reflected from a window passed through a crystal of Iceland spar, only one ray of light came through instead of two. It is now known that light can be polarized by oblique reflection; the reflecting surface absorbs waves that vibrate in one direction and reflects those that vibrate in the others.

Scientific studies of polarization continued throughout the nineteenth century, but practical applications were frustrated because polarizing substances like Iceland spar were scarce and fragile. One of the best polarizers was "herapathite," or sulfate of iodo-quinine, a synthetic

### Summary 137

1. Newton argued that light could not consist of waves, like sound, for two reasons. First, light travels in straight lines and doesn't go around corners; second, light can be polarized. The first objection is overcome by recognizing that the wavelength of light is small so diffraction effects are not usually observed when light strikes large objects.

2. When it was recognized (by Young and Fresnel, around 1820) that light waves are transverse, rather than longitudinal, it was possible to explain polarization of light by the wave theory.

3. Various crystals can separate light polarized in different directions.

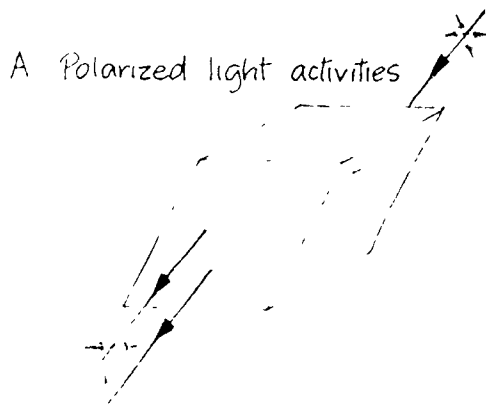

Double refraction by a crystal of Iceland spar. The incident light is termed "unpolarized," but in effect consists of equal intensities of vertically and horizontally polarized light. The crystal separates these two components, transmitting them through the crystal in different directions and with different speeds.

crystalline material which transmits polarized light of all colors with almost no absorption. The needle-like crystals of herapathite absorb only light which is vibrating in the direction of the long axis. Herapathite was discovered by an English physician, William Herapath, in 1852, but the crystals were so fragile that there seemed to be no way of using them.

In 1928, Edwin H. Land, a student at Harvard, invented a polarizing plastic sheet he called "Polaroid." His first polarizer consisted of a plastic film in which many microscopic crystals of herapathite are imbedded. The crystals are needle-shaped, and when the plastic is stretched they line up in one direction, so that they all polarize light in the same way. Later, Land improved Polaroid by using polymer molecules composed mainly of iodine in place of the herapathite crystals.

The properties of Polaroid are easily demonstrated. Hold the lens of a pair of Polaroid sunglasses in front of one eye and look at a shiny surface or light from the blue sky. Rotate the lens. You will notice that, as you do so, the light alternately brightens and dims; you must rotate the lens through an angle of  $90^\circ$  to go from maximum brightness to maximum dimness.

How does the polarizer work? If the light that strikes the lens is polarized mainly in one direction, and if this direction happens to coincide with the direction of the long molecules, then the wave will be absorbed because it will set up vibrations within the molecules, and lose most of its energy in this way. However, if the wave is polarized mainly in a direction perpendicular to the direction of the molecules, it will go through the lens without much absorption. If the light that strikes the lens is originally unpolarized—that is, a mixture of waves polarized in various directions—then the lens will transmit those waves that are polarized in one direction, and absorb the rest, so that the transmitted wave will be polarized.

Interference and diffraction effects seem to require a wave model for light. To explain polarization phenomena, the model has to be based on transverse waves. Thus we conclude that the model for light which best explains the characteristics of light considered so far is one which pictures light as a transverse wave motion.

- 
6. What two objections did Newton have to a wave model of light?
7. What is "unpolarized" light?
- 

### ants, too

The bee's eyes are sensitive to the polarization of daylight, enabling a bee to navigate by the sun, even when the sun is low on the horizon or obscured. Following the bee's example, engineers have equipped airplanes with polarization indicators for use in arctic regions.

See "Popular Applications of Polarized Light" in Project Physics Reader 4.

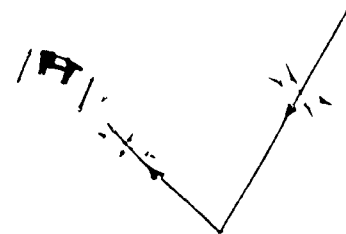

The clip-on sunglasses shown have polarizing lenses that transmit only vertically polarized light. The light reaching the lenses consists of both "unpolarized" diffuse light and horizontally polarized glare. The lenses block the glare and the horizontal component of the diffuse light.



13 8 The ether. One thing seems to be missing from the wave model for light. In Chapter 12, we assumed that waves are a special kind of motion that propagates in some substance or "medium," such as a rope or water. What is the medium for the propagation of light waves?

### Summary 13.8

1 Scientists invented a hypothetical medium for the propagation of light waves, the "ether".

2 In order to explain the properties of light such as high speed and transversality, it was necessary to presume that the ether is stiff, solid, and has a low density.

"Ether" was originally the name for Aristotle's fifth element, the pure transparent fluid that filled the heavenly spheres, it was later called "quintessence" by scientists in the Middle Ages (see Sections 2.1 and 6.4).

### A. Miscellaneous photography Activities

Actually you can twist (shear) a liquid or gas, but the shear modulus is much smaller than in solids and the corresponding

In order to transmit transverse waves, the medium must have some tendency to return to its original shape when it has been deformed. As Thomas Young remarked, "This hypothesis of Mr. Fresnel is at least very ingenious, and may lead us to some satisfactory computations; but it is attended by one circumstance which is perfectly appalling in its consequences ... It is only to solids that such a lateral resistance has ever been attributed: so that ... it might be inferred that the luminiferous ether, pervading all space, and penetrating almost all substances, is not only highly elastic, but absolutely solid!!!"

transverse waves are heavily damped. Waves on water are not, of course, transmitted through the medium as light was supposed to be transmitted through the ether. They are surface phenomenon

● For example, if the ether had the same density as air it would have to be about  $10^{12}$  times as stiff, or, if it had the same stiffness as air, it would have to be about  $10^{-12}$  times as dense.

Is air the medium for light waves? No, because light can pass through airless space—for example, the space between the sun and the earth. Even before it was definitely known that there is no air between the sun and the earth, Robert Boyle had tried the experiment of pumping almost all of the air out of a glass container, and found that objects inside remained visible.

In Newtonian physics it is impossible to imagine motion without specifying what is moving. Scientists therefore invented a hypothetical medium for the propagation of light waves. This medium was called the ether.

In the seventeenth and eighteenth centuries the ether was imagined as an invisible fluid of very low density, which could penetrate all matter and fill all space. It might somehow be associated with the "effluvium"—something that "flows out"—that was used to explain magnetic and electric forces. Early in the nineteenth century, however, Young and Fresnel showed that light waves must be transverse in order to explain polarization. But the only kind of transverse waves known to Young and Fresnel were waves in a solid medium. A liquid or a gas cannot transmit transverse waves, for the same reason that you cannot "twist" a liquid or a gas.

Since light waves are transverse, and only a solid medium can transmit transverse waves, nineteenth-century physicists assumed that the ether must be a solid. Furthermore, it must be a very stiff solid, because the speed of propagation is very high, compared to other kinds of waves such as sound. Alternatively, it might have a very low density; as was stated in Chapter 12, the speed of propagation increases with the stiffness of the medium, and decreases with its density. ●

B. it is absurd to say that a stiff solid ether fills all space because we know that the planets move through space in accordance with Newton's laws, just as if they were going through a vacuum, with no resistance at all. And of course we ourselves feel no resistance when we move around in a space that transmits light freely.

For the moment we must leave the ether as an unsolved problem, just as it was for Newton and the poet Richard Glover who wrote, shortly after Newton's death:



A The camera does lie!

138

O had great Newton, as he found the cause  
By which sound rouls thro' th'undulating air,  
O had he, baffling time's resistless power,  
Discover'd what that subtle spirit is,  
Or whatsoe'er diffusive else is spread  
Over the wide-extended universe,  
Which causes bodies to reflect the light,  
And from their straight direction to divert  
The rapid beams, that through their surface pierce,  
But since embrac'd by th'icy arms of age,  
And his quick thought by times cold hand congeal'd,  
EVEN NEWTON left unknown this hidden power...

[Richard Glover, "A Poem on Newton."]

Why was it assumed that an "ether" existed which transmitted light waves?

What remarkable property must the ether have if it is to be the mechanical medium for the propagation of light?



"Music Hall Artist," drawing by Georges Seurat, 1888. Seurat's use of texture suggests not only the objects and people but also the space between them.

Seurat was strongly influenced by reading in science. His 'pointillist' paintings constructed entirely of color dots are believed to be partially due to the atomistic view in physics

131 A square card 3 cm on a side is held 10 cm from a small  
penlight bulb, and its shadow falls on a wall 18 cm behind the  
card. What is the size of the shadow on the wall? (A diagram  
might be useful) *7.5 cm*

132 An experiment devised by Galileo to determine whether or  
not the propagation of light is instantaneous is described by  
him as follows:

Let each of two persons take a light contained in a lan-  
tern, or other receptacle, such that by the interposition  
of the hand, the one can shut off or admit the light to  
the vision of the other. Next let them stand opposite  
each other at a distance of a few cubits and practice un-  
til they acquire such skill in uncovering and occulting  
their lights that the instant one sees the light of his  
companion he will uncover his own. After a few trials  
the response will be so prompt that without sensible error  
(*Svario*) the uncovering of one light is immediately fol-  
lowed by the uncovering of the other, so that as soon as  
one exposes his light he will instantly see that of the  
other. Having acquired skill at this short distance let  
the two experimenters, equipped as before take up posi-  
tions separated by a distance of two or three miles and  
let them perform the same experiment at night, noting  
carefully whether the exposures and occultations occur  
in the same manner as at short distances, if they do,  
we may safely conclude that the propagation of light  
is instantaneous, but if time is required at a distance  
of three miles which, considering the going of one light  
and the coming of the other, really amounts to six, then  
the delay ought to be easily observable...

But he later states:

In fact I have tried the experiment only at a short dis-  
tance, less than a mile, from which I have not been able  
to ascertain with certainty whether the appearance of  
the opposite light was instantaneous or not, but if not  
instantaneous it is extraordinarily rapid.

*Distance too small, etc*

- Why was Galileo unsuccessful in the above experiment?
- Could Galileo have been successful if he had altered his  
experiment in some reasonable way? *NO*
- Why do you suppose that the first proof of the finite  
speed of light was based on celestial observations rath-  
er than terrestrial observations? *Large distance involved*
- What do you think is the longest time that light might  
have taken in getting from one observer to the other  
without the observers detecting the delay? Use this  
estimate to arrive at a lower limit for the speed of  
light that is consistent with Galileo's description  
of the result. Was Galileo's experiment completely  
unsuccessful? *A lower limit was found*

133 Romer's prediction described in Sec. 13.2 was based on the  
natural "clock" provided by the revolution of Io, the second  
satellite of Jupiter. During each revolution Io passes through  
Jupiter's shadow, the average time interval between successive  
immersions into the shadow (or between successive emergences  
from the shadow) is the period of revolution of Io. Romer used  
over 70 observations made by himself and the French astronomer  
Picard to calculate the period to be 42 hr, 28 min, 33 sec. He  
discovered that all values of the apparent period measured while  
the earth was receding from Jupiter were greater than the average  
period he had calculated, and all values measured while the  
earth was approaching Jupiter were less than the average period.  
Romer could explain these deviations by assuming that light has  
a finite speed. Deviations would then be a result of the changes  
in the distance of the earth from Jupiter which occurred while  
the period was being measured. The time required for light to  
travel this change in distance was the deviation observed. For

example, if during one revolution of Io the earth moved from E to F as shown in the accompanying diagram, the apparent period would be greater than the average period, whereas if the earth moved from E to E' it would be less than the average period.

E F

E' E'



Note that when the earth is receding from Jupiter it is necessary to observe the emergences of Io from the shadow, whereas when the earth is approaching Jupiter, it is necessary to observe the immersions of Io into the shadow.

In the following questions assume that the radius of the earth's orbit is  $1.5 \times 10^8$  meters.

- How far does the earth travel along its orbit during one revolution of Io? (Note that the period of Io is  $1 \frac{3}{4}$  days)  $4.4 \times 10^9 \text{ m}$
- If the greatest deviation observed for Io's period is very close to 15 seconds, calculate the speed of light. Ignore the very small difference between the chord and the arc of the earth's orbit with which you are concerned. Also ignore the orbital motion of Jupiter which occurs during the measurement of the period of Io.  $3.0 \times 10^8 \text{ m/sec}$
- Köber's actual data have been grouped for convenience and five successive groups are shown below plotted against the apparent deviation for those groups (each group consists of several values of the period which are measured during a two- or three-month interval). The positive deviations are for the earth receding from Jupiter and the negative deviations are for the earth approaching Jupiter.

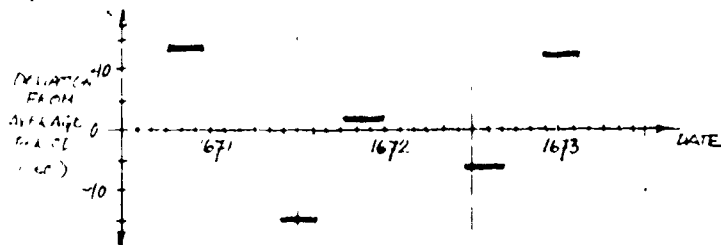

After carefully considering the meaning of the graph, sketch in the curve that best fits the given points. Examine the regularity of the curve, what time interval is required for the curve to complete one cycle and start repeating the pattern again? Can you explain the observed regularity and cyclical nature of the curve? "conjunction cycle"

134 A convenient unit for measuring astronomical distances is the light year, defined to be the distance that light travels in one year. Calculate the number of meters in a light year to two significant figures  $9.5 \times 10^{15} \text{ m}$

135 What time would be required for a spaceship having a speed of  $1/1000$  that of light to travel the 4.3 light years from the earth to the closest known star other than the sun, Proxima Centauri? Compare the speed given for the spaceship with the speed of approximately 11 km/sec that a rocket from the earth to Venus must have when leaving the earth's atmosphere.  $4.3 \text{ years}$   
 $28 \text{ times}$

- 13 6 Find the path from point A to any point on mirror M and then to point B that has the shortest overall length (solve this by trial and error, perhaps by experimenting with a short piece of string held at one end by a tack at point A). Notice that the shortest distance between A, M and B is also the least-time path for a particle traveling at a constant speed from A to M to B. A possible path is shown but it is not necessarily the shortest one. What path would light take from A to M to B? *The shortest*

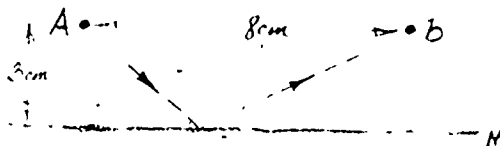

- 13 7 What is the shortest mirror in which a 6-foot tall man can see himself entirely? (Assume that both he and the mirror are vertical and that he places the mirror in the most favorable position.) Does it matter how far away he is from the mirror? Do your answers to these questions depend on the distance from his eyes to the top of his head? *36 in.*

- 13 8 Suppose the reflecting surfaces of every visible object were somehow altered so that they completely absorbed any light falling on them; how would the world then appear to you? *Only self-luminous objects would be visible*

- 13.9 Objects are visible if their surfaces reflect light in many different directions, enabling our eyes to intercept cones of reflected light diverging from each part of the surface. The accompanying diagram shows such a cone of light (represented by 2 diverging rays) entering the eye from a book.

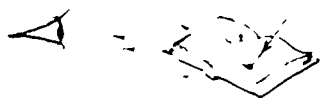

Draw clear straight-line diagrams to show how a pair of diverging rays can be used to help explain the following phenomena (here is a chance to use your knowledge of reflection and refraction).

- The mirror image of an object appears to be just as far behind the mirror as the object is in front of the mirror. *Reflection*
  - A pond appears shallower than it actually is. *Refraction*
  - A coin placed in an empty coffee mug which is placed so that the coin cannot quite be seen becomes visible if the mug is filled with water. *Refraction*
- 13 10 Due to atmospheric refraction we see the sun in the evening for some minutes after it is really below the horizon, and also for some minutes before it is actually above the horizon in the morning.
- Draw a simple diagram to illustrate how this phenomenon occurs. *Refraction*
  - The fact that this refraction by the atmosphere occurs is good evidence for the variation in density of the atmosphere; what does it indicate about the density variation? *Inverse with height*

- 13 11 Newton supposed that the reflection of light off shiny surfaces is due to "some feature of the body which is evenly diffused over its surface and by which it acts upon the ray without contact". The simplest model for such a feature would be a repulsive force which acts only in a direction perpendicular to the surface. In this question you are to show how this model predicts that the angles of incidence and reflection must be equal. Proceed as follows:

- Draw a clear diagram showing the incident and reflected rays. Also show the angles of incidence and reflection ( $\theta_i$  and  $\theta_r$ ). Sketch a coordinate system in your diagram that has an x-axis parallel to the surface and a y-axis perpendicular to the surface. Note that the angles of incidence and reflection are defined to be the angles between the incident and reflected rays and the y-axis.

kinetic energy of particles  $\frac{1}{2}mv^2$ ;  
 kinetic energy of  $mv_x = mv \sin \theta$   
 expressions for  
 incident  $mv_y = mv \cos \theta$

reflecting surface  
 perpendicular  
 you have  $\frac{1}{2}mv^2$  and  $mv_x$   
 reflected  
 incident energy conservation

components of  
 $mu_x = mu \sin \theta_r$ ,  $mu_y = mu \cos \theta_r$   
 equate x-components of momentum

plane  
 attractive  
 surface  
 the surface  
 of the particle

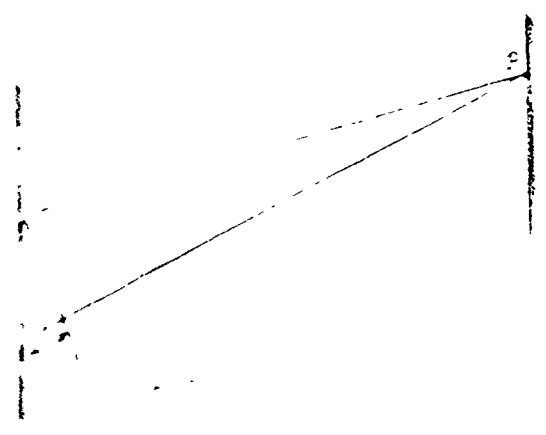

path of particle  
 pattern of  
 screen  
 interference  
 phase  
 path  
 if

$$\Delta s = (m + \frac{1}{2})\lambda, \text{ where } m = 0, 1, 2, 3,$$

separation in the  
 separation  
 Red  
 color  
 increase?  
 Increased fringe separation  
 (slits are moved  
 apart) Increased fringe separation  
 themselves are  
 fringe separation

fringes what  
 pres-  
 fringes

- 13.15 Recalling diffraction and interference phenomena from Chapter 12, show that the wave theory of light can be used to explain the bright spot in the center of the shadow of a disk illuminated by a point source.

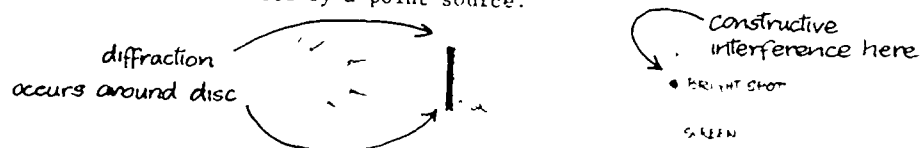

- 13.16 Green light has a wavelength of approximately  $5 \times 10^{-7}$  meters. What frequency corresponds to this wavelength? Compare this  $6 \times 10^{14}$  cps frequency to the frequency of the radio waves broadcast by a radio station you listen to. (Hint: Remember  $v = f\lambda$ .)  
 $10^{10} \times \text{AM}$ ,  $10^7 \times \text{FM}$

- 13.17 Poetry often reflects contemporary ideas in science; the following poem is an excellent example of this.

Some range the colours as they parted fly,  
 Clear-pointed to the philosophic eye,  
 The flaming red, that pains the dwelling gaze,  
 The stainless, lightsome yellow's gilding rays,  
 The clouded orange, that betwixt them glows,  
 And to kind mixture tawny lustre owes;  
 All-cheering green, that gives the spring its dye:  
 The bright transparent blue, that robes the sky;  
 And indigo, which shaded light displays,  
 And violet, which, in the view decays.  
 Parental hues, whence others all proceed;  
 An ever-mingling, changeful, countless breed,  
 Unravel'd, variegated, lines of light.  
 When blended, dazzling in promiscuous white

Richard Savage, The Wanderer

- a) Would you or would you not classify the poet Richard No. Savage as a "nature philosopher"? Why? Expresses Newton's color theory
- b) Compare this poem with the one in Sec. 13.5 by James Thomson; which poet do you think displays the better understanding of physics? Which poem do you prefer? open ended

- 13.18 One way to achieve privacy in apartments facing each other across a narrow courtyard while still allowing residents to enjoy the view of the courtyard and the sky above the courtyard is to use polarizing sheets placed over the windows. Explain how the sheets must be oriented for maximum effectiveness.

Polarizing axes must be perpendicular to each other.

- 13.19 To prevent car drivers from being blinded by the lights of approaching autos, polarizing sheets could be placed over the headlights and windshields of every car. Explain why these sheets would have to be oriented the same way on every vehicle and must have their polarizing axis at  $45^\circ$  to the vertical.

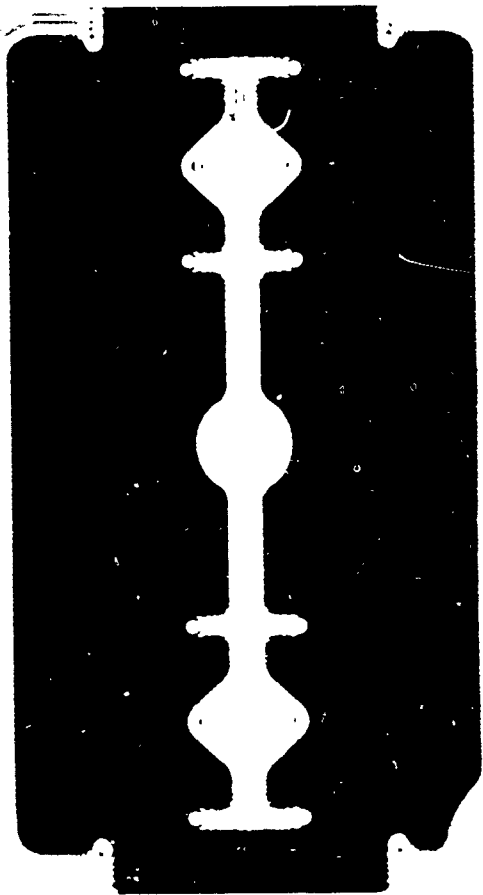

Diffraction fringes around a  
razor blade.



## Chapter 14 Electric and Magnetic Fields

Section		Page
14.1	Introduction	35
14.2	The curious properties of lodestone and amber: Gilbert's De Magnete	35
14.3	Electric charges and electric forces	39
14.4	Forces and fields	44
14.5	The smallest charge	52
14.6	Early research with electric charges	54
14.7	Electric currents	56
14.8	Electric potential difference	57
14.9	Electric potential difference and current	60
14.10	Electric potential difference and power	60
14.11	Currents act on magnets	61
14.12	Currents act on currents	64
14.13	Magnetic fields and moving charges	65

An inside view of "Hilac:" heavy ion linear accelerator at Berkeley, California. In this device electric fields accelerate charged atoms to high energies.

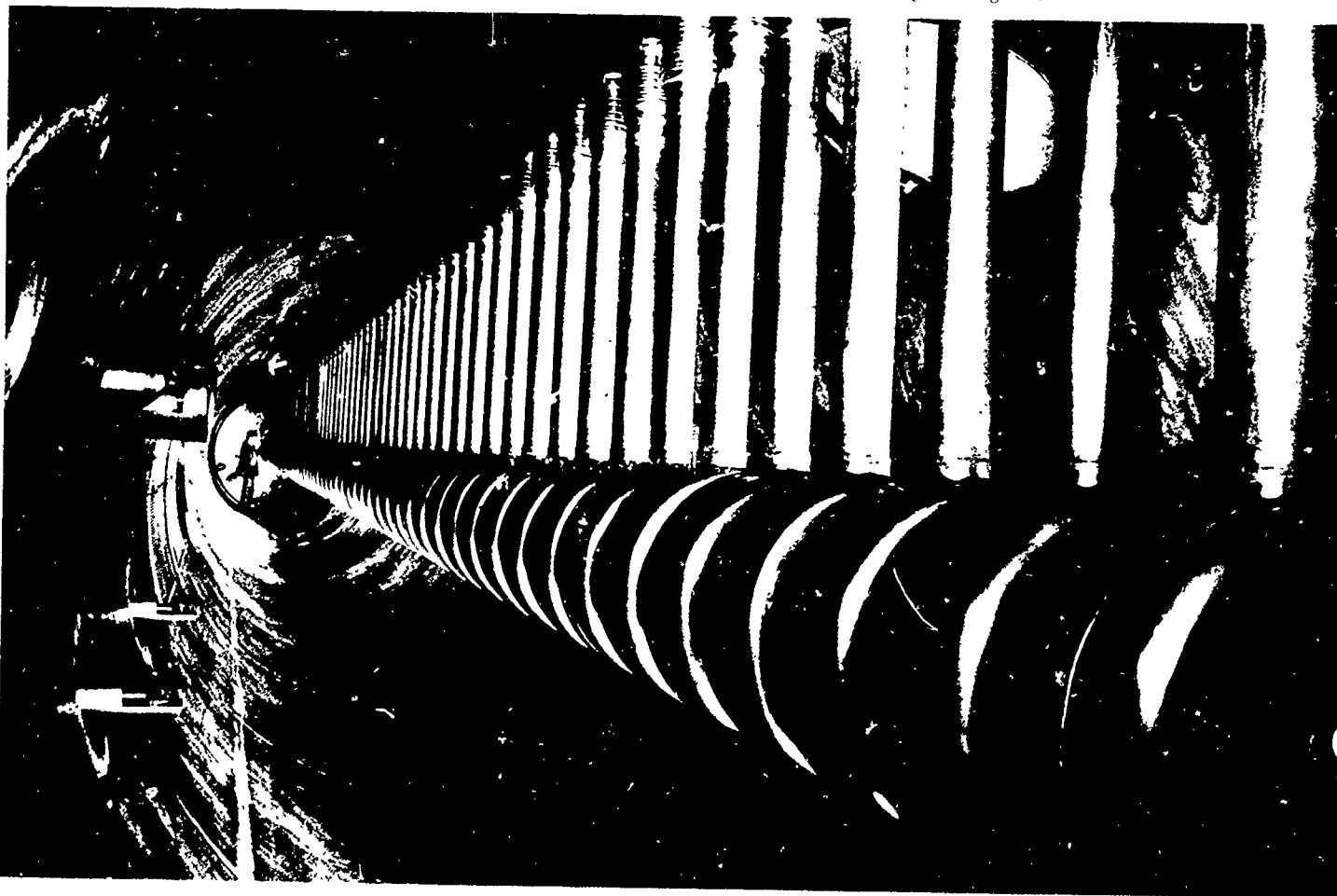

**14.1 Introduction.** The subject "electricity and magnetism" makes up a large part of modern physics, and has important connections with almost all other areas of physics and chemistry. Because it would be impossible to study this subject comprehensively in the time available in an introductory course, we consider only a few major topics which will be needed as a foundation for later chapters. The major applications of the information in this chapter are: the development of electrical technology (Chapter 15), the study of the nature of light and electromagnetic waves (Chapter 16), and the study of properties of atomic and subatomic particles (Units 5 and 6).

In this chapter we will first treat electric charges and the forces between them—very briefly, since you are probably already somewhat familiar with this topic. Next, we will show how the idea of a "field" simplifies the description of electric and magnetic forces, especially in situations where several charges or magnetic poles are present.

An electric current is made up of moving charges. By combining the concept of field with the idea of "potential energy" (Unit 3), we will be able to establish quantitative relations between current, voltage and power. These relations will be needed for the practical applications to be discussed in Chapter 15.

At the end of this chapter we shall come to the relation between electricity and magnetism, a relation having important consequences both for technology and basic physical theory. We will begin by looking at a simple physical phenomenon: the interaction between moving charges and magnetic fields.

**14.2 The curious properties of lodestone and amber: Gilbert's *De Magnete*.** The substances amber and lodestone have aroused interest since ancient times. Amber is sap that long ago oozed from softwood trees and, over many centuries, hardened into a semitransparent solid ranging in color from yellow to brown. It is a handsome ornamental stone when polished, and it sometimes contains the remains of insects that were caught in the sticky sap. Ancient Greeks recognized a curious property of amber: if it is rubbed vigorously, it attracts nearby objects such as bits of straw or grain seeds.

Lodestone is a mineral with equally unusual properties. It attracts iron. When suspended or floated, a piece of lodestone turns to a particular orientation. The first known written description of the navigational use of lodestone as a compass dates from the late twelfth century. Its properties were known even earlier in China. Today lodestone would be called magnetized iron ore.

#### Summary 14.1

This chapter will cover electric charges and the forces between them, the field concept, currents, voltages, and the interaction between currents (or moving charges) and magnetic fields

#### Summary 14.2

1. William Gilbert, in his book *De Magnete* (1600), summarized existing knowledge about the properties of lodestone and amber, criticized various theories, and proposed that the earth itself is a lodestone.

2. Gilbert showed that electric and magnetic forces are different.

The histories of lodestone and amber are the early histories of magnetism and electricity. The modern developments in these subjects began in 1600 with the publication in London of William Gilbert's book De Magnete. Gilbert (1544-1603) was an influential physician, who served as Queen Elizabeth's chief physician. During the last twenty years of his life, he studied what was already known of lodestone and amber, made his own experiments to check the reports of other writers, and summarized his conclusion in De Magnete.

Gilbert's first task in his book was to review and criticize what had previously been written about the lodestone (see p. 37). Gilbert reports various theories proposed to explain the cause of magnetic attraction; one of the most popular theories was suggested by the Roman scientist Lucretius:

Lucretius is known as one of the early writers on atomic theory; see Prologue to Unit 5.

Lucretius...deems the attraction to be due to this, that as there is from all things a flowing out ["efflux" or "effluvium"] of minutest bodies, so there is from iron an efflux of atoms into the space between the iron and the lodestone—a space emptied of air by the lodestone's atoms (seeds); and when these begin to return to the lodestone, the iron follows, the corpuscles being entangled with each other.

Gilbert himself did not accept the effluvium theory as an explanation for magnetic attraction, although he thought it might apply to electrical attraction.

When it was discovered that lodestones and magnetized bars of iron tend to turn so as to have a certain direction on the surface of the earth, many authors attempted to concoct explanations. But, says Gilbert,

...they wasted oil and labor, because, not being practical in the research of objects of nature, being acquainted only with books, being led astray by certain erroneous physical systems, and having made no magnetical experiments, they constructed certain explanations on a basis of mere opinions, and old-womanishly dreamt the things that were not. Marcilius Ficinus chews the cud of ancient opinions, and to give the reason of the magnetic direction seeks its cause in the constellation Ursa...Paracelsus declares that there are stars which, gifted with the lodestone's power, do attract to themselves iron....All these philosophers...reckoning among the causes of the direction of the magnet, a region of the sky, celestial poles, stars...mountains, cliffs, vacant space, atoms, attractional...regions beyond the heavens, and other like unproved paradoxes, are worldwide astray from the truth and are blindly wandering.

Gilbert's De Magnete is a classic in scientific literature. It included reports of intensive experiments and speculation about the magnetic properties of the earth. The richness of Gilbert's work is evident on the next page, where the title page, some excerpts and some sketches have been reproduced.

Gilbert himself pointed out the real cause of the motion of magnets: the earth itself is a lodestone. To demonstrate his theory Gilbert did an experiment, a rather ingenious one, to test his model: he prepared spherical lodestones and showed that a magnetized needle placed on the surface of such a lodestone will act in the same way as a compass needle does

*Tractatus, sive Physiologia Nova*  
D. E.  
**MAGNETE,**  
Magneticisq; corporibus & magno  
Magnete tellure, sex libris comprehensus.  
a **GUILIELMO GILBERTO** Colce-  
strensi, Medico Londinensi.

*In quibus ea, quae ad hanc materiam spectant, plurimis  
& Argumentis & experimentis exactissime absolutissi-  
meq; tractantur & explicantur.*

Omnia nunc diligenter recognita, & emendatius quam ante  
in lucem edita, aucta & figuris illustrata, opera & studio D.  
**WOLFGANGI LOCHMANS,** I. U. D.  
& Mathematici.

*Ad calcem libri adiunctus est Index capitum, Rerum & Verborum  
locupletissimus, qui in priorae editione desiderabatur.*



**SEDINI,**  
Typis **GOTZIANIS:**  
ANNO M. DC. XXXIII.

"...the lodestone was found, as seems probable, by iron-smelters or by miners in veins of iron ore. On being treated by the metallurgists, it quickly exhibited that strong powerful attraction of iron...And after it had come forth as it were out of darkness and out of deep dungeons and been honoured of men on account of its strong and marvellous attraction of iron, then many ancient philosophers and physicians discoursed of it...These record only that the lodestone attracts iron: its other properties were all hid. But lest the story of the lodestone should be uninteresting and too short, to this one sole property then known were appended certain figments and falsehoods...For example, they asserted that a lodestone rubbed with garlic does not attract iron, nor when it is in presence of a diamond.

...we do not propose just now to overturn with arguments...the other many fables about the lodestone...Abobali rashly asserts, when held in the hand it cures pains of the feet and cramps; ..as Pictorius sings, it gives one favor and acceptance with princes and makes one eloquent,...Arnoldus de Villanova fancies that the lodestone frees women from witchcraft and puts demons to flight; Marbodaeus, a Frenchman, says that it can make husbands agreeable to wives and may restore wives to their husbands. In such-like follies and fables do philosophers of the vulgar sort take delight..."

From Gilbert's *De Magnete*.

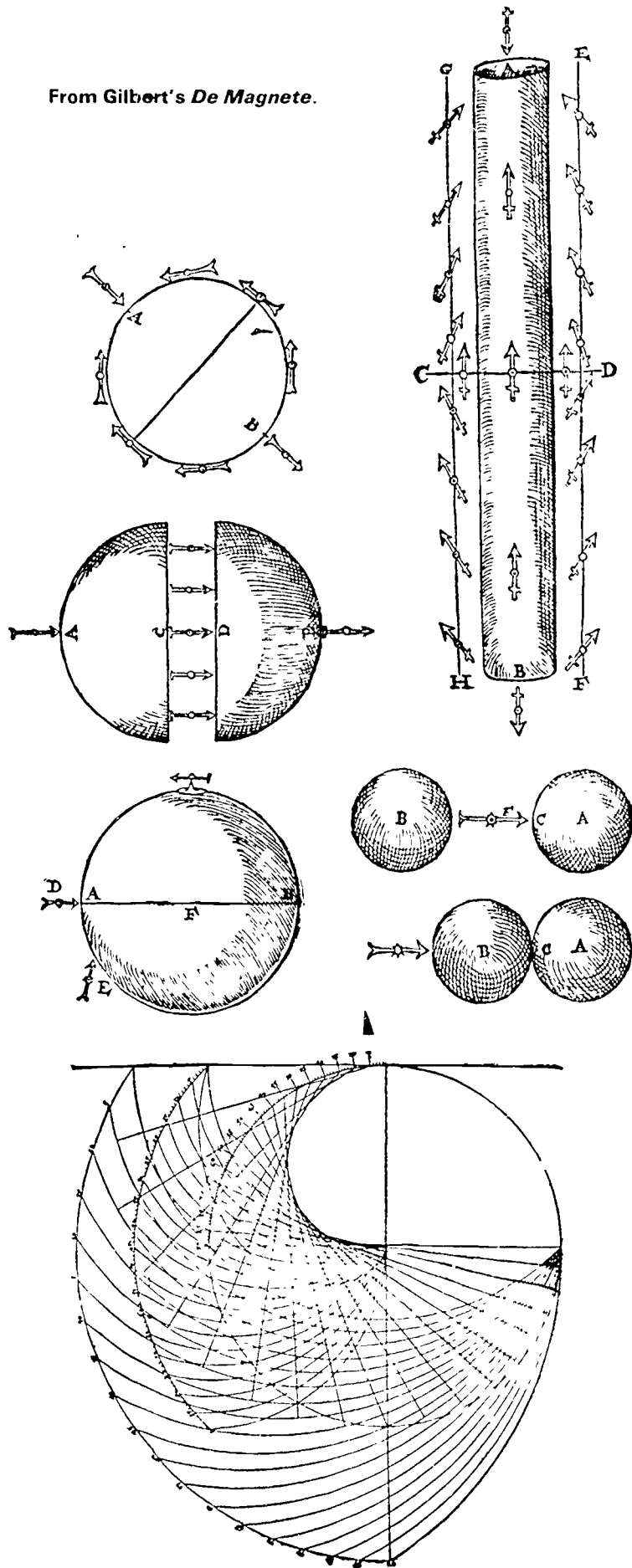

at different places on the earth's surface. If the directions of the needle are marked with chalk on the lodestone, they will form meridian circles (like the lines of equal longitude on a globe) which converge at two opposite ends or "poles." At the poles, the needle will be perpendicular to the surface of the lodestone. Halfway between, along the "equator," the needles will lie along the surface. These directions can also be shown by placing small bits of iron wire on the surface.

The explanation of the action of magnets is now generally given by means of the idea that magnets set up "fields" around themselves. The field can then act on distant objects. Gilbert's description of the force exerted by his spherical lodestone (which he called the 'terrella,' meaning 'little earth') comes close to the modern field concept:

The terrella sends its force abroad in all directions, according to its energy and its quality. But whenever iron or other magnetic body of suitable size happens within its sphere of influence it is attracted; yet the nearer it is to the lodestone the greater the force with which it is borne toward it.

Gilbert also included a discussion of electricity in his book. He introduced the word electric as the general term for "bodies that attract in the same way as amber." Gilbert showed that electric and magnetic forces are different. For example, a lodestone always attracts other magnetic bodies, whereas an electric exerts its attraction only when rubbed. On the other hand, an electric can attract small pieces of many different substances, whereas magnetic forces act only between a few types of substances. Objects are attracted to an electric along a line directly toward its center, but a magnet always has two regions (poles) toward which attraction draws other magnets.

In addition to summarizing the known facts of electricity and magnets, Gilbert's work suggested new research problems to scientists in the centuries that followed. For example, Gilbert thought that while the poles of two lodestones might repel each other, electrics could never exert repulsive forces. But in 1646, Sir Thomas Browne published the first account of electric repulsion, and in the eighteenth century several other cases of repulsion as well as attraction were discovered. To systematize these observations a new concept, electric charge, was introduced. In the next section we will see how this concept can be used to describe the forces between electrified bodies.

How did Gilbert demonstrate that the earth behaves like a spherical lodestone?

How does the attraction of objects by amber differ from the attraction by lodestone?

The idea of "field" was invented by Michael Faraday early in the nineteenth century, and developed further by Kelvin and Maxwell (see Secs. 14.4 and 16.2).

"electric" comes from the Greek word *ἤλεκτρον*, *electron*, meaning "amber." Note that this word was originally a noun but has now become an adjective.

Iron oxide crystals in the magnetic field of a bar magnet.





Point out that this is philosophically a very important point. It is sometimes stated that physics does not deal with what things are, but rather with what they do; the philosophies dealing with this viewpoint are operationalism, positivism, etc. 143

**14.3 Electric charges and electric forces.** As Gilbert strongly argues, the facts of electrostatics (forces between electric charges at rest) are better learned in the laboratory than by just reading about them. This section, therefore, is only a brief summary.

We begin with the idea of electric charge. Charge is best defined not by saying what it is, but what it does. Two kinds of electric charges can be identified. A glass rod that has been rubbed by silk becomes charged. This charge is given the arbitrary name positive charge. The other kind of charge appears on a rubber rod stroked with wool or fur and is termed negative.

When we talk about the electric charge on an object we usually mean the slight excess (or net) charge of either kind existing on this object. Actually, any piece of matter large enough to be visible contains a large amount of electric charge, both positive and negative. If the amount of positive charge is equal to the amount of negative charge, this piece of matter will appear to have no charge at all, so we can say that the effects of the positive and negative charges simply cancel each other when they are added together. (This is one advantage of calling the two kinds of charge positive and negative, rather than, for example, x and y.)

Two experimental facts that are easily demonstrated are the following:

1. Like charges repel each other. A body that has a net positive charge repels any other body that has a net positive charge. That is, two glass rods that have both been rubbed will tend to repel each other. A body that has a net negative charge repels any other body that has a net negative charge.

2. Unlike charges attract each other. A body that has a net positive charge attracts any body that has a net negative charge, and vice versa.

The electrical force law. What is the "law of force" between electric charges? In other words, how does the force depend on the amount of charge, and on the distance between the charged objects?

The first evidence of the nature of the force law between electrical charges was obtained in an indirect way. About 1775, Benjamin Franklin performed the following experiment: He charged a silver can and put the can on an insulating stand. When he hung a cork near the outside of the can, the cork was strongly attracted. But when he lowered the cork, suspended by a silk thread, into the can, he found that no electric

#### Summary 14.3

1 Observations on attraction and repulsion of electrified objects were systematized by saying that some objects have positive charge and others have negative charge. Like charges repel each other and unlike charges attract each other

Rarely is this imbalance more than 1 part in 1 million-million

#### DA7 Electrostatic demonstrations



Benjamin Franklin (1706-1790), American statesman, printer, scientist and writer. He was greatly interested in the phenomena of static electricity; his famous kite experiment and invention of the lightning rod gained him wide recognition; he is shown here observing the electrical behavior of a bell connected to a lightning rod. His other inventions include the Franklin stove, bifocals and the harmonica. While in Philadelphia, Franklin organized a debating club which developed into the American Philosophical Society, and he helped establish an academy which later became the University of Pennsylvania.

T31:  $\vec{E}$  field inside  
conducting sphere

Joseph Priestley (1733-1804), a Unitarian minister, was persecuted in England for his radical ideas. One of his books was burned, and a mob looted his home because of his sympathy with the French Revolution. He moved to America, the home of Benjamin Franklin, who had stimulated Priestley's interest in science. He developed carbonated drinks (soda-pop) and experimented in electricity, in addition to his well-known work on oxen.

2. Priestley suggested, on the basis of an experiment by Benjamin Franklin, that electric forces are inversely proportional to the square of the distance. Priestley reasoned by analogy with gravitational forces; in both cases there is no force on an object inside a hollow sphere.

3. Charles Coulomb confirmed by direct experiment that electric forces vary as  $1/R^2$ , and also that they are proportional to the product of the charges on the two objects:

$$F_{el} = k \left( \frac{q_A q_B}{R^2} \right)$$

4. In the MKSA system the unit of charge, the 'coulomb', is defined in terms of the unit of current, the ampere:

$$1 \text{ coul} = 1 \text{ amp sec}$$

In this system the proportionality constant  $k$  in Coulomb's law comes out to have the value  $k = 9 \times 10^9 \text{ Nm}^2/\text{coul}^2$ .

The symbol  $q$  is used for amount of charge; see below for units.

The force is exerted on the cork no matter what its position was inside the can.

Franklin did not understand why the walls of the can did not attract the cork when it was inside the can, even though there was a force when the cork was outside. He asked his friend Joseph Priestley to repeat the experiment.

Priestley verified Franklin's results, and went on to make a brilliant theoretical deduction from them. He remembered from Newton's Principia that Newton had proved that gravitational forces behave in a similar way. Inside a hollow sphere, the net gravitational force on an object, computed by adding up all the forces exerted by the parts of the sphere, is exactly zero. This is a result which can be deduced mathematically from the law that the gravitational force between any two individual pieces of matter is inversely proportional to the square of the distance between them. Priestley therefore proposed that electrical forces might also vary inversely as the square of the distance. (See page 42.)

Priestley's proposal was based on bold reasoning by analogy. Such reasoning could not by itself prove that electrical forces are inversely proportional to the square of the distance between charges. But it strongly encouraged other physicists to test the hypothesis by experiment.

The French physicist Charles Coulomb provided direct experimental confirmation of the inverse-square law for electric charges suggested by Priestley. Coulomb used a torsion balance that he invented and carefully calibrated to measure the force between two small charged spheres. The balance is shown on the opposite page. A balanced insulating rod is shown suspended by a thin silver wire which twists when a force is exerted on the end of the rod to make it rotate about the vertical axis.

By measuring the twisting force for different separations  $R$  of the spheres, Coulomb showed that the force varied in proportion to  $1/R^2$ . Thus he directly confirmed the suggestion that the force of electrical repulsion for like charges varies inversely as the square of the distance between charges. With a slightly modified procedure, he confirmed a similar law of attraction for unlike charges.

Coulomb also demonstrated that the magnitude of the electric force at a given distance is proportional to the product of the charges,  $q_A q_B$ , on the two objects. This was a remarkable accomplishment, since there was not yet any accepted method for measuring quantitatively the amount of charge on an object. However, Coulomb could show that if a charged



metal sphere touches an uncharged sphere of the same size, the total charge will be shared between the two spheres equally. Thus, starting with a given amount of charge on one sphere and several other identical but uncharged spheres, Coulomb could produce charges of one-half, one-quarter, one-eighth, etc., the original amount. By thus varying the charges  $q_A$  and  $q_B$  independently, he could show, for example, that when each is reduced by one-half, the force between A and B is reduced to one-quarter its previous value.

Coulomb summarized his results in a single equation which describes the force that two small charged spheres A and B exert on each other:

$$F_{el} = k \frac{q_A q_B}{R^2} \quad (14.1)$$

where  $k$  is a constant whose value depends on the units of charge and length that are being used. This form of the law of force between two electric charges is now called Coulomb's law.

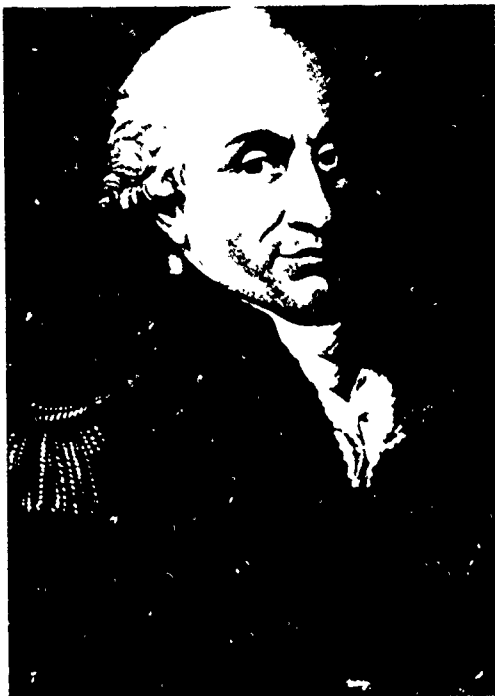

Charles Augustin Coulomb (1738-1806) was born into a family of high social position and grew up in an age of political unrest. He studied science and mathematics and began his career as a military engineer. He later settled in Paris, and a work, The Theory of Simple Machines, gained him membership in the French Academy of Sciences. While studying machines Coulomb invented his torsion balance, with which he carried out intensive investigations on electrical forces.

5 An electrically charged object can also attract an uncharged object by 'electrostatic induction' (rearrangement of the charges inside the uncharged object).

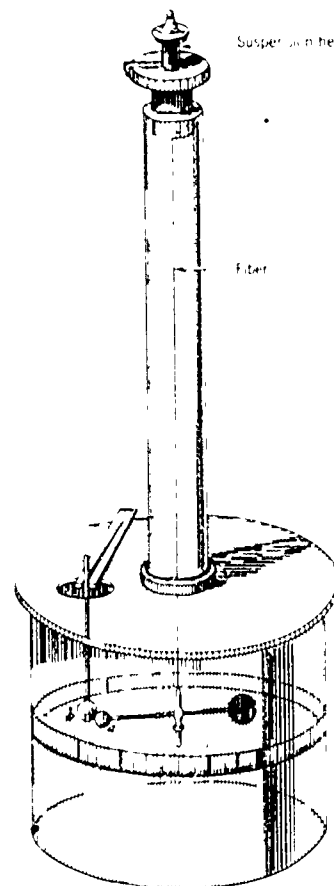

The documentary film "People and Particles" shows an experiment to see if Eq. 14.1 applies to charges at distances as small as  $10^{-15}$  cm. (It does.)

Consider any point  $P$  inside a charged conducting sphere. For any small patch of charge on the sphere there is a corresponding patch on the other side of  $P$ .

The electric field due to each patch is proportional to the area of the patch and inversely proportional to the square of the distance from  $P$ . But the areas of the patches are directly proportional to the squares of the distances from  $P$ .

So the distance and area factors balance—the fields due to the two patches at  $P$  are exactly equal and opposite.

Since this is true for all pairs of charge patches, the net electric field at  $P$  is zero.

### Electric Shielding

In general, charges on a closed conducting surface arrange themselves so that the electric field strength inside is zero (on the condition, of course, that there is no charge inside). Furthermore, the region inside any closed conductor is "shielded" from any external electric field. This is a very

important practical principle. Whenever stray electric fields might disturb the operation of some electric equipment, the equipment can be enclosed by a shell of conducting material. Some uses of electric shielding are suggested in the accompanying photographs.

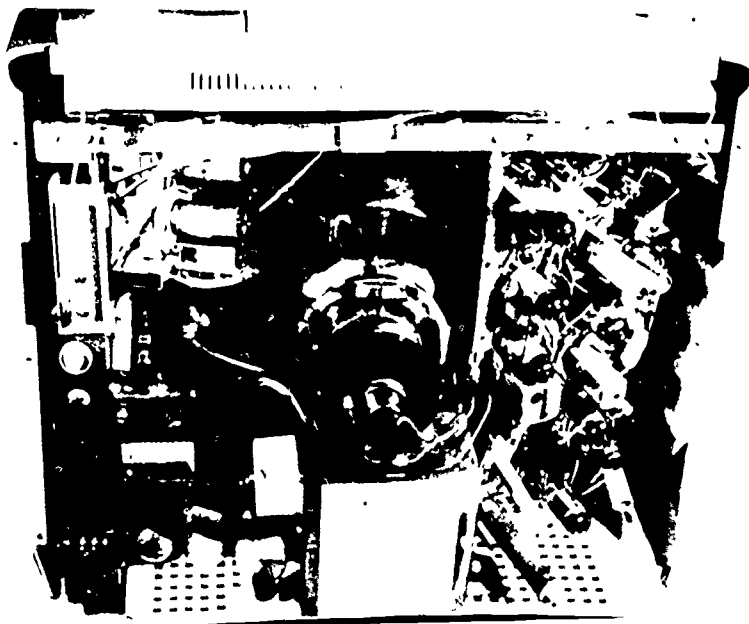

Portions of the chassis and the conducting paint on the picture tube also have shielding functions.

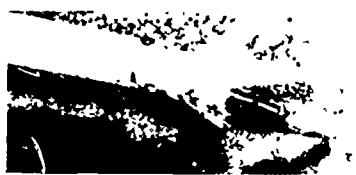

A section of shielded cable such as is seen in the TV photo above, showing how the two wires are surrounded by a conducting cylinder woven of fine wires.

Closeup of a tube in the tuning section of the TV set on the left. Surrounding the tube is a collapsible metal shield. Partly shielded tubes can be seen elsewhere in that photo.



unit of charge. We shall use Eq. (14.1) to define a unit of charge. For example, we could arbitrarily let the magnitude of  $k$  be exactly 1 and define a unit charge so that two unit charges separated by a unit distance exert a unit force upon them. There is a set of units based on this system, however, in the system of electrical units we shall therefore be referring to here, the "MKS-A" system, the unit of charge is derived from the unit of current, the "ampere." The unit of charge is called the "coulomb," and is defined as the amount of charge that flows past a point in a wire in one second when the current is equal to one ampere.

The ampere, or "amp," is a familiar unit because it is frequently used to measure the current drawn by electrical appliances. The amount of current drawn by a 100-watt light bulb in a 110-volt circuit is approximately one ampere.

Since one coulomb is approximately the amount of charge that goes through a 100-watt bulb in one second, it might occur that the coulomb is a fairly small amount of charge. However, one coulomb of excess charge all collected in one place is unmanageably large. By experiment, the constant  $k$  in Coulomb's law (Eq. 14.1) is found to equal about nine billion newton-meters squared per coulomb squared ( $9 \times 10^9 \text{ Nm}^2/\text{coul}^2$ ). This means that two objects, each with a net charge of one coulomb, separated by a distance of one meter, would exert forces on each other of nine billion newtons. This force is roughly the same as a weight of one million tons. We never observe such large forces, because we can't actually collect that much excess charge in one place, or exert enough force to bring two such charges so close together. The mutual repulsion of like charges is so strong that it is difficult to keep a charge of more than a thousandth of a coulomb on an object of ordinary size. If you rub a pocket comb on your sleeve, the net charge on the comb will be far less than one millionth of a coulomb. Lightning discharges usually take place when a cloud has accumulated a net charge of a few hundred coulombs distributed over its very large volume.

The reason that an ordinary light bulb can have one coulomb per second going through its filament is that the moving charges, which in this case are negative, are passing through a static arrangement of positive charges.

Electrostatic induction. You have probably observed that an electrically charged object can often attract small pieces of paper even though the paper seems to have no net charge itself. (It exerts no force on other pieces of paper.) At first sight it might appear that this attraction is not covered by Coulomb's law, since the force ought to be zero if

The definition of the unit of current, based on Ampère's discovery of the force between currents, will be discussed in Sec 14.12  
Meter-Kilogram-Second-Ampere

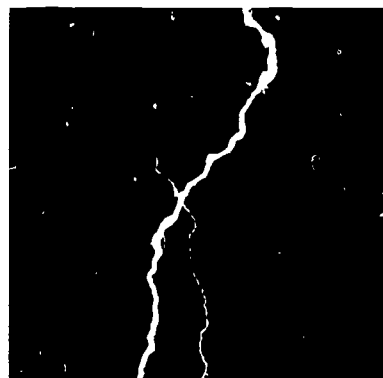

A stroke of lightning averages about 40,000 amperes and transfers 1 coulomb of charge from the cloud to the ground, or vice versa.



either  $q_A$  or  $q_B$  is zero in Eq. (14.1). However, we can explain the attraction if we recall that uncharged objects contain equal amounts of positive and negative electric charges. When an electrified body is brought near a neutral object, electrical forces may rearrange the positions of the charges in the neutral object (see diagram). For example, if a negatively charged rod is held near a piece of paper, some of the positive charges in the paper will shift toward the side of the paper nearest the rod, and a corresponding amount of negative charge will shift toward the other side. The positive charges are then slightly closer to the rod than the negative charges are, so the attraction is greater than the repulsion. (Remember that the force gets weaker with the square of the distance, according to Coulomb's law; it would only be one fourth as great if the distance were twice as large.) Hence there will be a net attraction of the charged body for the neutral object.

The rearrangement of electric charges inside or on the surface of a neutral body due to the influence of a nearby object is called electrostatic induction. In Chapter 16 we will see how the theory of electrostatic induction played an important role in the development of the theory of light.

What experimental fact led Priestley to propose that electrical forces and gravitational forces change with distance in a similar way?

What two facts about the force between electric charges did Coulomb demonstrate?

If the distance between two charged objects is doubled, how is the electrical force between them affected?

Are the coulomb and ampere both units of charge?

If an object is found to be attracted by both positively charged bodies and negatively charged bodies, does this mean that there are really three kinds of charge?

The fact that the rubbed comb can pick up a small piece of paper shows that this electric force is greater than the gravitational force exerted on the paper by the entire earth.

E34 Electric forces  
Coulomb's law

**14.4 Forces and fields.** Gilbert described the action of the lodestone by saying it had a "sphere of influence" surrounding it. Any other magnetic body coming inside this sphere will be attracted, and the strength of the attractive force will be greater at places closer to the lodestone. In modern language, we would say that the lodestone is surrounded by a magnetic field.

Because the word "field" is used in many ways, we will begin by discussing some familiar fields and then proceed gradually to develop the ideas of physical fields.

One part of the concept of field is illustrated by playing fields. The football field, for example, is a place where teams compete according to rules which confine the signifi-



**Pressure and Velocity Fields**

\* Actually the "500 millibar height."

These maps, adapted from those of the U.S. Weather Bureau, depict two fields, air pressure at the earth's surface and high-altitude\* wind velocity, for three successive days.

Air pressure at earth's surface.

High altitude wind velocity.

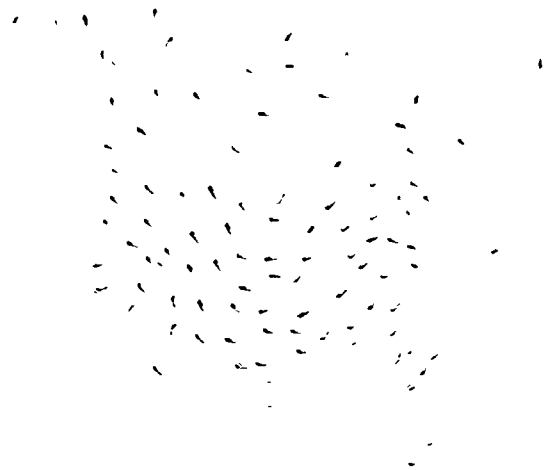
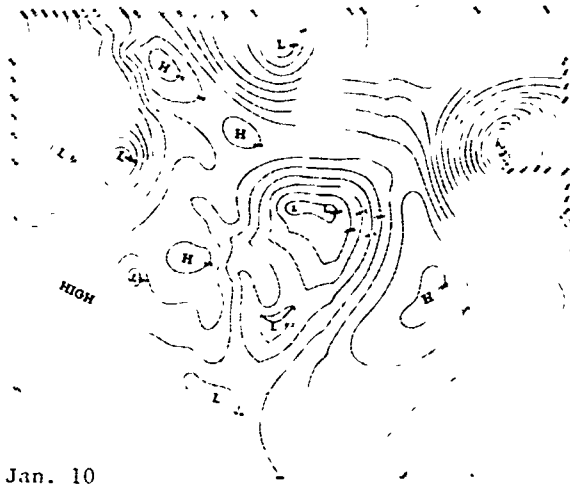

Jan. 10

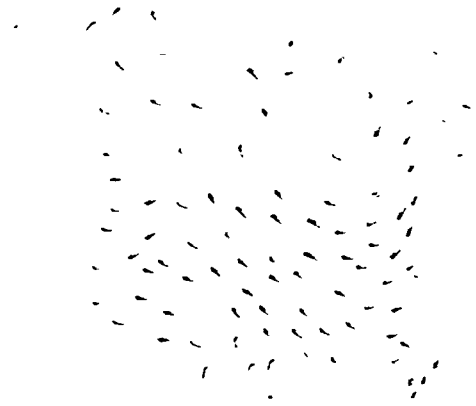
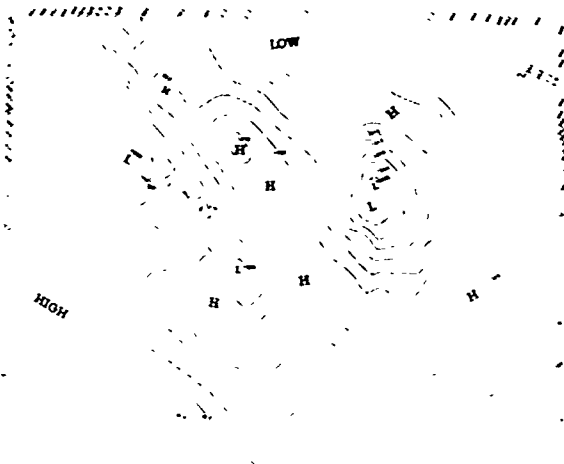

Jan. 11

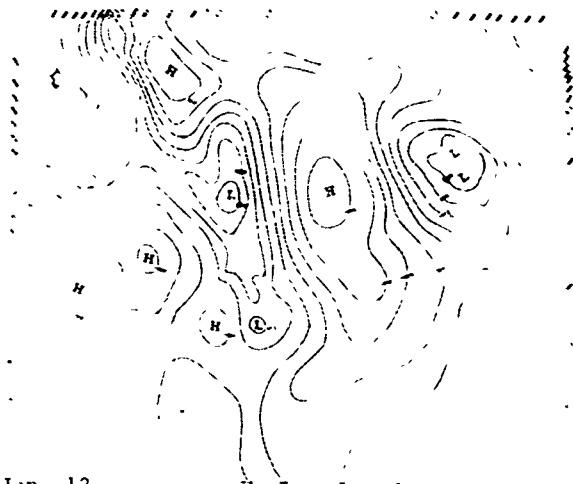

Jan. 12

same speed as the car. We can think of the sound field as being steady but moving with the horn. At any instant we could assign a number to each point in the field to represent the intensity of sound. At first the sound is faintly heard as the weakest part of the field reaches you. Then the more intense parts of the field go by, and the sound seems louder. Finally, the loudness diminishes as the sound field and its source (the horn) move away.

c) Here you are walking in a temperature field which is intense where the sidewalk is in the sunshine and weaker where it is in the shade. Again, we could assign a number to each point in the field to represent the temperature.

Notice that the first two of these fields are produced by a single source. In (a) the source is a stationary street lamp, in (b) it is a moving horn. In both cases the field strength gradually decreases as your distance from the source increases. But in the third case the field is produced by a complicated combination of influences: the sun, the clouds in the sky, nearby buildings, local geography and other factors. Yet the description of the field itself may be just as simple as for a field produced by a single source: one number is assigned to each point in the field.

So far, all examples were simple scalar fields—no direction was involved in the value of the field at each point. On the opposite page are maps of two fields for the layer of air over the surface of North America for three consecutive days. There is a very important difference between the field mapped at the left and that mapped at the right; the air pressure field is a scalar field, while the wind velocity field is a vector field. For each point in the pressure field, there is a single number, a scalar quantity which gives the value of the field at that point. But for each point in the wind velocity field the value of the field is given by both a number and a direction, that is, by a vector.

These field maps are particularly useful because they can be used more or less successfully to predict what the subsequent conditions of the field might be. Also, by superimposing the maps on each other, we could get some idea of how the fields are related to each other.

The term "field" is actually used by physicists in three different senses: to mean the value of the field at a point in space, the collection of all values, and the region of space in which the field has values. In reading the rest of this chapter, try to decide which meaning is appropriate each time the term is used.

*A: Detecting electric fields*

*The Weather Bureau has a different convention for vectors. Ask students to discuss the advantages and disadvantages*

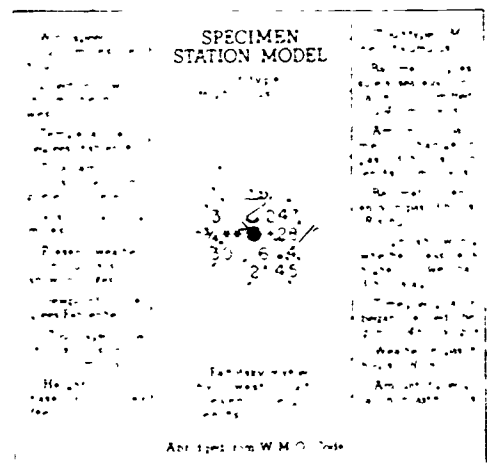

Key for a U.S. Weather Bureau Map. How many fields are represented for each station?



The gravitational field. Before returning to electricity and magnetism, and just to illustrate the idea of a field, we take as an example the gravitational field of the earth. Recall that the force exerted by the earth on some object outside the surface of the earth, for example upon the moon, acts in a direction toward the center of the earth. The gravitational field is a vector field and could be represented by arrows pointing toward the center of the earth.

The strength of the gravitational field depends on the distance from the center of the earth, since, according to Newton's theory, the magnitude of the gravitational force is inversely proportional to the square of the distance R:

$$F_{\text{grav}} = G \frac{Mm}{R^2} \quad (14.2)$$

where M is the mass of the earth, m is the mass of the test body, and R is the distance between the centers of earth and other body (G is the gravitational constant).

Is the value of the gravitational field at each point just the same as  $F_{\text{grav}}$  exerted on a body at that point? No, because  $F_{\text{grav}}$  depends on the mass of the test body, and we want our definition of field to depend only on the properties of the source, not on the properties of the test body on which the force acts. The force itself must of course depend on the mass of the test body, but it is useful to think of the field as existing in space and having a certain direction and magnitude at every point, whether or not there is any test body present for it to act on.

A definition of gravitation field that satisfies the above requirement follows easily if we rearrange Eq. (14.2):

$$F_{\text{grav}} = m \frac{GM}{R^2}$$

We then define the gravitational field,  $\vec{g}$ , to have a magnitude  $\frac{GM}{R^2}$  and the same direction as that of  $\vec{F}_{\text{grav}}$ . Thus  $\vec{g}$  is determined by the strength of the source (the mass M) and the distance (R) from the source but does not depend on the mass of the object which the force acts upon. The force is then simply the product of the mass of the test body and the field,

$$\vec{F}_{\text{grav}} = m\vec{g} \quad (14.3)$$

and

$$\vec{g} = \frac{\vec{F}_{\text{grav}}}{m} \quad (14.4)$$

In other words, the gravitational field at a point in space is defined as the quotient of the gravitational force which would act on a body of mass m at that point, and the mass m. However, the gravitational field at a point in space is determined by more than one source. The moon is acted on by the sun as well as by the earth, and to a smaller extent by the

*You might want to discuss such philosophical problems as, do trees falling make a noise when no one is there to hear them? The point here is that fields make it possible to talk about what's going on without constant explicit reference to the observer*

From now on, "field" is defined to be independent of the test body on which a force may act.



other planets. Thus, to generalize Eq. (14.4), we can take  $\vec{F}_{\text{grav}}$  to be not just the force of gravity due to one source, but the net gravitational force due to all sources acting on that region.

Electric fields. In general, the strength of any force field can be defined in the same way as for gravitational fields if there is a force law similar to Newton's in which the force is proportional to a product of quantities characteristic of the two interacting bodies. Thus for electric forces, according to Coulomb's law (Eq. 14.1), the force depends on the product of the charges of the two bodies, rather than the product of the masses. For a charge  $q$  in the electric field due to charge  $Q$ , Coulomb's law describing the force on  $q$  can be written as:

$$F_{\text{el}} = k \frac{Qq}{R^2} \quad \text{or} \quad F_{\text{el}} = q \frac{kQ}{R^2} .$$

As in the case of the gravitational field, the expression for force has been broken up into two parts. One part,  $\frac{kQ}{R^2}$ , which depends only on the "strength"  $Q$  of the source and distance  $R$  from it, is the electric field due to  $Q$ . The second part,  $q$ , is a property of the body being acted on. Thus we define the electric field,  $\vec{E}$ , due to charge  $Q$  to have magnitude  $\frac{kQ}{R^2}$ , and the same direction of  $\vec{F}_{\text{el}}$ . The electric force is then the product of the test charge and the field,

$$\vec{F}_{\text{el}} = q\vec{E} \quad (14.5)$$

and

$$\vec{E} = \frac{\vec{F}_{\text{el}}}{q} \quad (14.6)$$

Therefore the electric field at a point in space is defined as the quotient of the electric force acting on a test charge placed at that point and the magnitude of the test charge. Of course, if the electric field at a point is due to more than one source, we define the electric field in terms of the net electric force on test charge  $q$ .

So far we have passed over a complication that we did not encounter in dealing with gravitation. There are two kinds of electric charge, positive (+) and negative (-), and the forces they experience in an electric field are opposite in direction. Long ago the arbitrary choice was made of defining the field value as the force exerted on a positive charge, divided by the magnitude of that charge. This choice makes it easy to remember the direction of the electric force vector, if we adopt the convention that a minus sign in front of a vector means that it has the opposite direction. If we are given the direction and magnitude of the field vector  $\vec{E}$  at a



*We use Franklin's convention for the sign of electric charges, in which the direction of the current was taken as the direction in which positive charge would move. It turned out, however, that in metals the "negative" charges would move, so that the "current" direction is opposite to the charge flow.*

## Visualizing Electric Fields

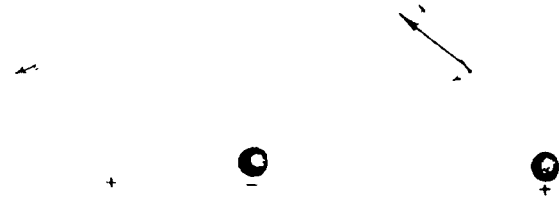
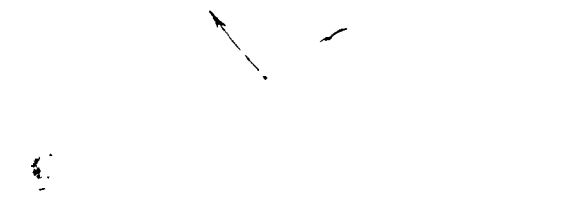

Rarely will we be interested in the field of a single charged sphere. If we want to be able to calculate the field values for a complicated array of charges, without actually taking some small test charge and moving it around in the field to measure the force, we need a rule for determining the field values of separate sources. A wide variety of experiments indicates that, at any point in an electric field, the field value produced by a combination of sources is just the vector sum of the field values produced by each source alone. Although we can be sure of this simple vector addition only to the limits of experimental accuracy, physicists assure that the principle is absolutely true.

A simple example of adding fields is finding the electric field produced by a pair of spheres with equal charges of opposite sign. The first frame in the margin indicates the field strength at a point P which would result from the presence of the (+) charge alone. The second frame shows the field strength at the same point which would result from the presence of the (-) charge alone. (The point P happens to be twice as far from the negative charge as from the positive charge, so the field strength is only half as great.) When both (+) and (-) charges are present, the electric field strength at the point is the vector sum of the individual field strengths, as indicated in the third frame.

Similarly for other pairs



These five photographs of objects in an electric field show fine fibre clippings suspended in oil. An electric field induces opposite charges on the two ends of every clipping. The clipping then lines up in the field.

Oppositely charged spheres

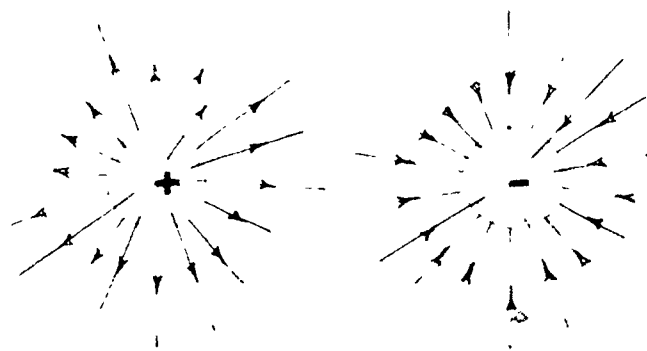

The map of an electric field is not easy to draw. A vector field can be assigned to the electric field strength at every point in space, but obviously we cannot illustrate that—our map would be totally black with arrows. The convention, which has been used for many years in physics is to draw a small number of lines which indicate the direction of the field. For example, the field around a charged sphere could be represented by a drawing like that in the margin. Notice that the lines, which have been drawn symmetrically around the sphere, are more closely spaced where the field is stronger. In fact, the lines can be drawn in three dimensions so that the density of lines represents the strength of the field. These lines, drawn to represent both

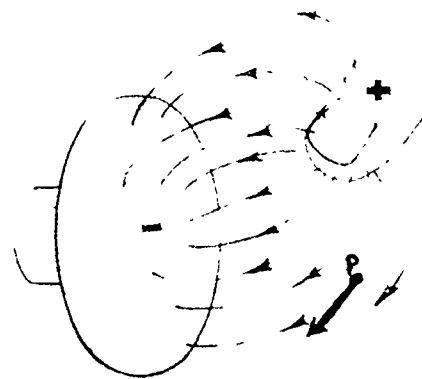

the direction and strength of the field, are called "lines of force." Around a single charged sphere the lines of force are straight and directed radially away from the center. When charge is distributed in a more complicated way, the lines of force may be curved. The direction of the field at a point is the tangent to the curved line of force at that point. Above, for example, we have drawn lines of force to represent the direction of the electric field between a charged fingertip and the oppositely charged surface of a door knob. The electric field vector  $\vec{E}$  at point P would be directed along the tangent to the curved line of force at P, and represented by the arrow at P. Note the difference: each line of force only shows direction, and terminates at a charged object or goes off to infinity. But the electric field vector  $\vec{E}$  at each point P is represented by an arrow of length drawn to scale to indicate magnitude E.

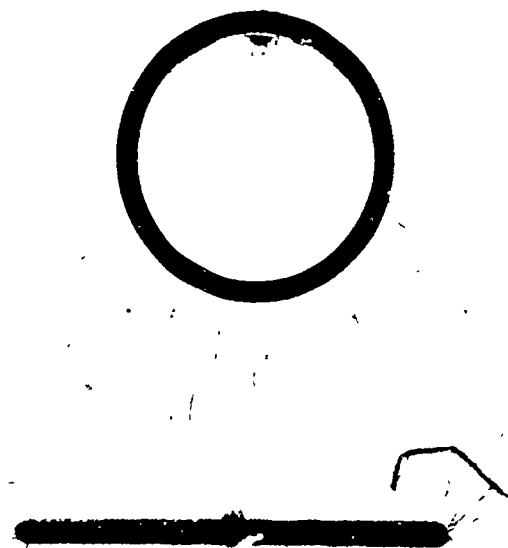
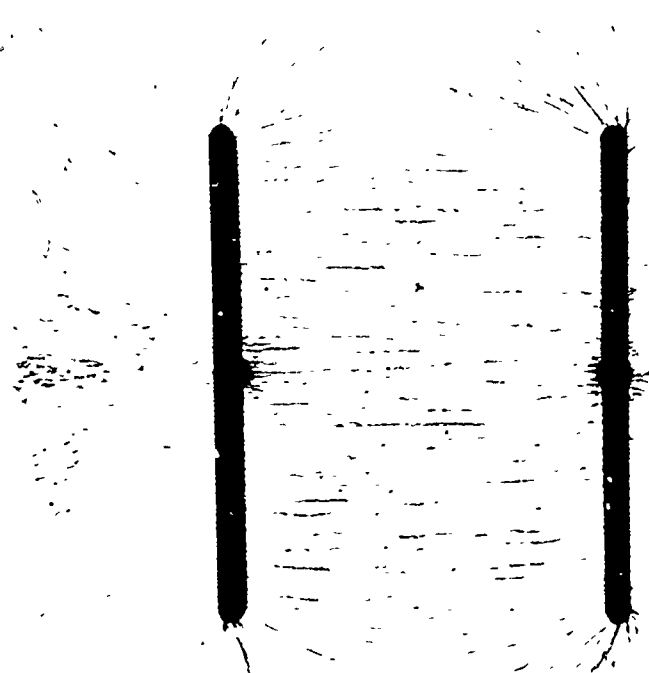

Oppositely charged cylinder and plate. (Notice the absence of field inside the cylinder.)

Oppositely charged plates. (Notice the uniformity of the field between them.)

point, then by definition the force vector  $\vec{F}$  acting on a charge  $q$  is  $\vec{F} = q\vec{E}$ . A positive charge, say  $+0.00001$  coulombs, placed at this point will experience a force  $\vec{F}$  in the same direction as  $\vec{E}$ . A negative charge, say  $-0.00001$  coulombs, will experience a force  $-\vec{F}$  of the same magnitude as  $\vec{F}$  but in the opposite direction. Changing the sign of  $q$  automatically changes the direction of  $\vec{F}$ .

Q8 What is the difference between a scalar field and a vector field?

Q9 What is the direction of  
a) the gravitational field, and  
b) the electric field, at a certain point in space?

Q10 Why would the field strengths  $\vec{g}$  and  $\vec{E}$  be unchanged in Equations (14.4) and (14.6) if  $m$  and  $q$  were doubled?

#### 14.5 The smallest charge. How strong are electric forces? In

Sec. 14.3 we mentioned the fact that an electrified comb can pick up a small piece of paper, so that in this case the electric force on the paper must exceed the gravitational force exerted on it by the earth. But before we can discuss such questions quantitatively, we will introduce a more natural or fundamental unit of charge which can always be associated with an object that has a definite mass. In modern physics it is most convenient to use the charge of an electron, one of the basic components of the atom. (Other properties of atoms and electrons will be discussed in Unit 5.)

A remarkable illustration of the strength of electric forces is the fact that, using an electric field that can be produced easily in the laboratory, we can balance the gravitational force on a tiny object, only big enough to be seen in a microscope but still containing several billion atoms, with the electrical force on a single electron. This fact is the basis of a method of measuring the electron charge in an experiment first done by the American physicist Robert A. Millikan in 1909. Although a further description of Millikan's experiment will be postponed until Sec. 18.3, its basic principle will be discussed here because it provides such a vivid connection between the ideas of force, field and charge.

Suppose a small body of mass  $m$ —an oil drop or small plastic sphere—carries a net negative electric charge of magnitude  $q$ . If we place the negatively charged body in an electric field  $\vec{E}$  directed downwards, there will be exerted on the body a force of magnitude  $qE$  in the upward direction. Of course there will also be a downward gravitational force  $mg$  on the object. The body will accelerate upward or downward,

#### Summary 14.5

1. Electric forces are so strong (compared, for example, to gravitational forces) that we can balance the gravitational force on an object containing several billion atoms by the electric force on a single electron. This fact is exploited in Millikan's oil-drop experiment, to determine the magnitude of the electronic charge

2. All possible charge in nature must be made up of multiples of some smallest charge  $e$ , the magnitude of the charge on the electron. The value of  $e$  is about  $1.6 \times 10^{-19}$  coulombs

Millikan chose fine droplets of oil from an atomizer to get very small masses. Also, the oil was convenient because of the low rate of evaporation of the droplet.

depending on whether the electric force or the gravitational force is greater. By adjusting the magnitude of  $\vec{E}$ , that is by changing the source that sets up a known electric field  $\vec{E}$ , we can balance the two forces.

What happens when the two forces are balanced? Remember that if no forces act on a body it can still be moving with constant velocity. However, in this case air resistance will soon destroy any original motion which the oil drop may have (when the oil drop is stationary, no frictional forces act on it); the drop will then be in equilibrium and will be seen to be suspended in mid-air. When this happens, we record the magnitude of the electric field strength  $E$ .

If the electric force balances the gravitational force, the following equation must hold:

$$qE = mg. \quad (14.7)$$

If we know the quantities  $E$ ,  $m$  and  $g$ , we can calculate  $q$  from this equation:

$$q = \frac{mg}{E}. \quad (14.8)$$

Let us assume that all possible charges in nature must be made up of multiples of some smallest charge, which we call  $e$ , the magnitude of the charge on the electron. (As we shall see, the results of the experiment confirmed the validity of this assumption.) Then we can write  $q = ne$  where  $n$  is a whole number.

To determine  $e$  from this equation, we would need to know  $n$ , the number of electron charges which make up the total charge  $q$ . We do not know  $n$ , but it is possible to calculate  $e$ , nevertheless, by repeating the experiment many times with a variety of small charges. If there is a smallest "electron charge,"  $e$ , then all the values of  $q$  which we obtain from this experiment should be multiples of that charge. For example, if all apples had the same mass, we could infer the mass of one apple by weighing several small bags of apples and looking for the largest common factor of each result. This is in effect what Millikan did, although he used many experimental refinements and a variety of measurement techniques. He arrived at the value for the electron charge of  $e = 1.6024 \times 10^{-19}$  coulomb. (For most purposes we can use the value of  $1.6 \times 10^{-19}$  coulomb.) This value agrees with the results of many other experiments done subsequently. No experiment has yet revealed a smaller unit of charge.

Q11 How can the small oil droplets or plastic spheres used in the Millikan experiment experience an electric force upward if the electric field is directed downward?

Q12 What do the results of the Millikan experiment indicate about the nature of electric charge?

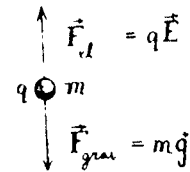

When  $mg$  and  $qE$  are balanced, frictional forces remain until the body stops moving

*Later the electron charge is given the symbol  $q_e$ .*

The magnitude of the charge on the electron is  $e$ ; its sign is negative.

Otto Von Guericke (1602-1686), Mayor of Magdeburg, Germany, designed a spectacular demonstration of the effects of air pressure. In the famous "Magdeburg Hemispheres" experiment (1654) he showed that two teams of a pair of horses could not pull apart two evacuated metal hemispheres; the external air pressure held them together.

**14.6 Early research with electric charges.** For many centuries the only way known to charge objects electrically was to rub them by hand. In 1663, Otto von Guericke made and described a machine that would aid in producing large amounts of charge by rubbing.

#### Summary 14.6

1 By the middle of the eighteenth century, machines had been invented which could produce large electrostatic charges, which could be stored in the Leyden jar

2 Benjamin Franklin proposed that the two kinds of charge are not really different - negative charge is simply a deficit of "electric fire" and positive charge is a surplus. Thus positive and negative charges can cancel out. This was an early expression of what is now called conservation of charge

...take a sphere of glass which is called a phial, as large as a child's head fill it with sulphur that has been pounded in a mortar and melt it sufficiently over a fire. When it is cooled again break the sphere and take out the globe and keep it in a dry place. If you think it best, bore a hole through it so that it can be turned around an iron rod or axle....

When he rested his hand on the surface of the sulphur globe while rotating it rapidly, the globe acquired enough charge to attract small objects.

By 1750 electrical machines were far more powerful. Large glass spheres or cylinders were whirled on axles which were in turn supported by heavy wooden frames. A stuffed leather pad was substituted for the human hands. The charge on the globe was often transferred to a large metal object (such as a gun barrel) suspended nearby.

These machines were powerful enough to deliver strong electrical shocks and to produce frightening sparks; they were not toys to be handled carelessly. In 1746 Pieter van Musschenbroek, a physics professor at Leyden, reported on an accidental and very nearly fatal discovery in a letter which begins, "I wish to communicate to you a new, but terrible, experiment that I would advise you never to attempt yourself." Musschenbroek was apparently trying to catch the electrical genie in a bottle, for he had a brass wire leading from a charged gun barrel to a jar filled with water. A student, J. N. S. Allamand, was holding the jar in one hand and Musschenbroek was cranking the machine. When Allamand tried to grab the brass wire with his free hand he received the shock of his life. They repeated the experiment, this time with Allamand at the crank and Musschenbroek holding the jar. The jolt was even greater than before; Allamand must have been giving his all at the crank. Musschenbroek wrote later that he thought "...it was all up with me..." and that he would not repeat the experience even if offered the whole kingdom of France. Word of the experiment spread rapidly, and the jar came to be called a Leyden jar. Such devices for storing electric charge are now called capacitors.

The Leyden jar came to Benjamin Franklin's attention. He performed a series of experiments with it, and published his analysis of its behavior in 1747. In these experiments Franklin showed that different kinds of charge (which we have called positive and negative) can cancel each other.

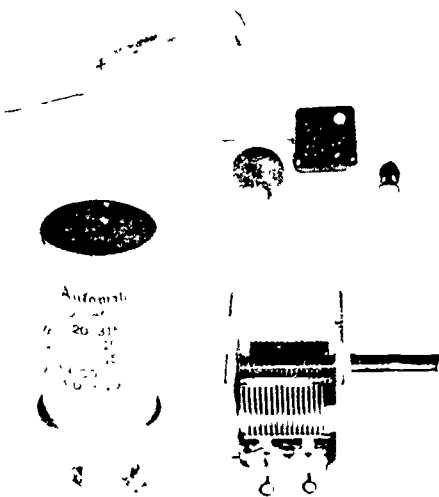

Capacitors, familiar to anyone who has looked inside a radio, are descendants of the Leyden jar. They have many different functions in modern electronics.



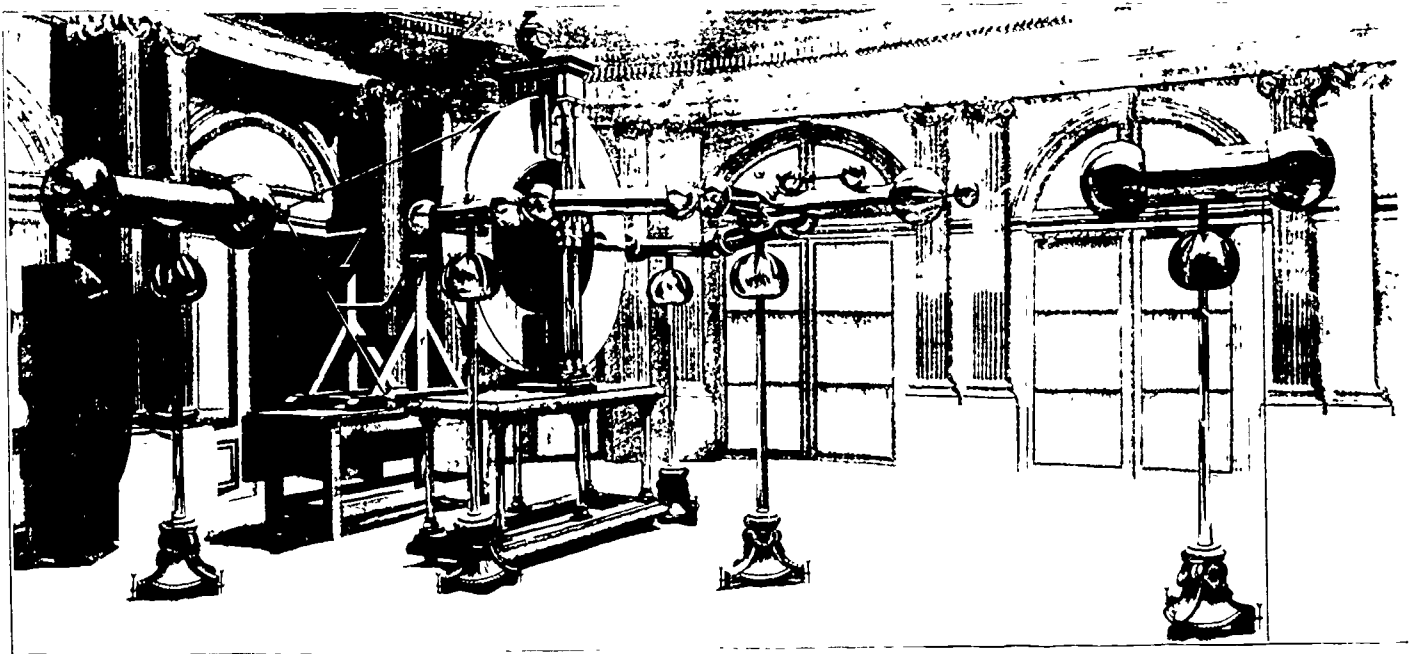

Electric Machines of the 1700's

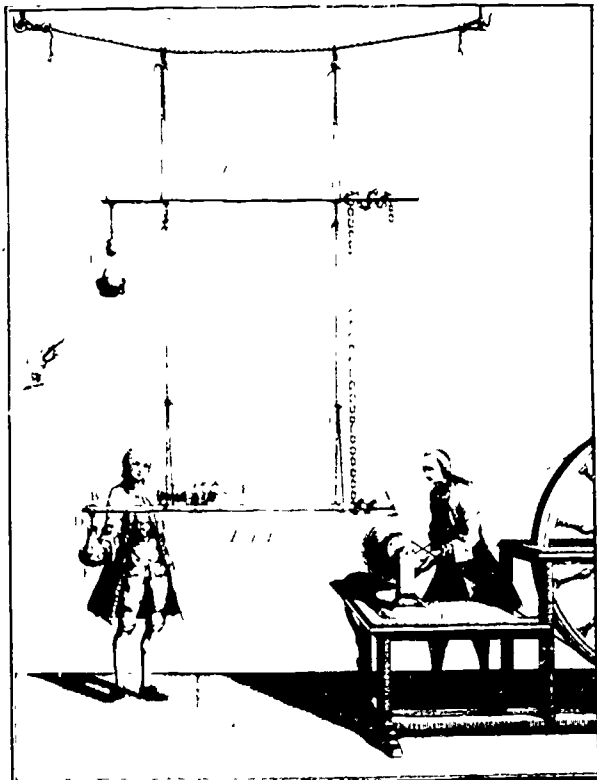

The "Levden experiment"

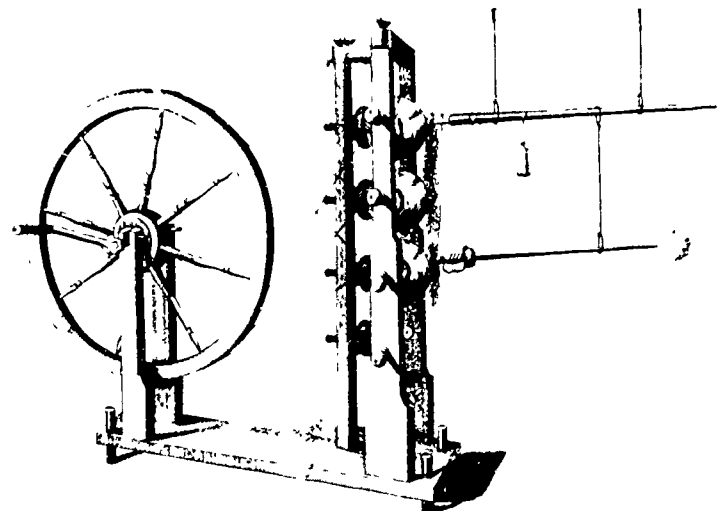

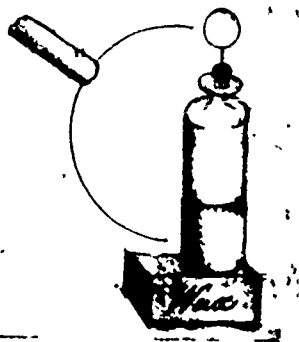

Franklin's drawing of a Leyden Jar. It can hold a large charge because positive charges hold negative charges on the other side of a nonconducting wall.

*In fact, although fundamental particles are both plus and minus, it is usually only the electrons which are transferred between charged bodies, since the positive ions are bound much more tightly. Franklin's view is, in a limited way, correct.*



Count Alessandro Volta (1745-1827) was given his title by Napoleon in honor of his electrical experiments. He was Professor of Physics at the University of Pavia, Italy. Volta showed that the electric effects previously observed by Luigi Galvani, in experiments with frog legs, were due to the contact of metals and not to any special kind of "animal electricity." (See the article "A Mirror for the Brain" in the Project Physics Reader 4 for an account of this controversy.)

Because of this cancellation he concluded that the two kinds of charge were not really different.

Franklin thought that only one kind of electricity need be invoked to explain all phenomena. He considered a body to be charged positively when it had an excess of "electrical fire" and to be charged negatively when it had a deficit of it. Although this view is no longer held today, it was sufficient to account for most facts of electrostatics known in the eighteenth century.

Franklin's theory also suggested that electric charge is not created or destroyed. Charges occurring on objects are due to rearrangement of electric charges--this was a redistribution rather than a creation of "electrical fire." Similarly, positive and negative charges can cancel or neutralize each other without being destroyed. These ideas are contained in the modern principle of conservation of charge, which is taken to be a very basic law of nature as are the conservation principles of momentum and energy.

Q. What experimental fact led Franklin to propose a theory based on the assumption of a single type of charge?

14.7 Electric currents. Until late in the eighteenth century, an appreciable movement of charge or electric current could be produced only by discharging a Leyden jar. Such currents last only for the instant it takes for the jar to discharge.

In 1800, Alessandro Volta discovered a much better way of producing electric currents. Volta demonstrated that the mere contact of objects is sometimes sufficient to produce an electric charge. If different metals, each held with an insulating handle, are put into contact and then separated, one will have a positive charge and the other a negative charge. Volta reasoned correctly that a much larger charge could be produced by stacking up several pieces of metal. This line of thought led him to undertake a series of experiments which led to an amazing finding, reported in a letter to the Royal Society in England in March of 1800:

Yes! the apparatus of which I speak, and which will doubtless astonish you, is only an assemblage of a number of good conductors of different sorts arranged in a certain way. 30, 40, 60 pieces or more of copper, or better of silver, each in contact with a piece of tin, or what is much better, of zinc, and an equal number of layers of water or some other liquid which is a better conductor than pure water, such as salt water or lye and so forth, or pieces of cardboard or of leather, etc. well soaked with these liquids....

I place horizontally on a table or base one of the metallic plates, for example, one of the silver ones, and on this first plate I place a second plate of zinc;

*Summary 14.7*

*Volta found that when different metals are put into contact, a flow of charge can be produced, thus he invented the electric cell.*

Note that the bottom-most and the top-most zinc discs are irrelevant and not included in the illustration 14.8

on this second plate I lay one of the moistened discs, then another plate of silver, followed immediately by another of zinc, on which I place again a moistened disc. I thus continue in the same way coupling a plate of silver with one of zinc, always in the same sense, that is to say, always silver below and zinc above or vice versa, according as I began, and inserting between these couples a moistened disc; I continue, I say, to form from several of these steps a column as high as can hold itself up without falling.

Volta found that the discharge of his apparatus, which he called a "battery," produced an effect similar to that of the Leyden jar but more powerful. He showed that one end, or "terminal," of the battery was charged positive, and the other negative. On the basis of such evidence, Volta argued that the electricity produced by his battery was the same as the electricity produced by rubbing amber, or by friction in electrostatic machines. Today this might seem obvious, but at the time it was important to show that many phenomena such as lightning, sparks from amber and currents from a battery have a common physical basis.

Volta's battery was important because it provided a means of producing a more or less steady current for a long period of time. Thus the properties of electric currents as well as static electric charges could be studied in the laboratory.

In what ways was Volta's battery superior to a Leyden jar?

**14.8 Electric potential difference.** The sparking and heating produced when the terminals of an electric battery are connected show that energy from the battery has been transformed into light, sound and heat energy. The battery converts chemical energy to electrical energy which, in turn, is changed to other forms of energy in the conducting path between the terminals. In order to understand electric currents and the way electric currents can be used to transport energy, it is necessary to understand electric potential difference. This term may be new to you, but actually you are already familiar with the idea under another name: "voltage".

Change in potential energy is equal to the work required to move an object frictionlessly from one position to another (Sec. 10.2). For example, the gravitational potential energy is greater when a book is on a shelf than it is when the book is on the floor; the increase in potential energy is equal to the work done raising the book from floor to shelf. This difference in potential energy depends on three factors: the mass of the book, the strength of the gravitational field, and the difference in height between the floor and the shelf.

Summary 14.8

1. The behavior of electric currents can be understood with the help of the concept of electric potential difference (voltage), defined as the ratio of the change in electric potential energy of a charge to the magnitude of the charge. The unit of potential difference, the volt, equals 1 joule/coulomb. 57

A. An 11¢ battery  
A Voltaic pile

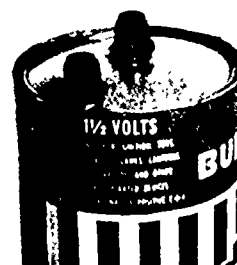
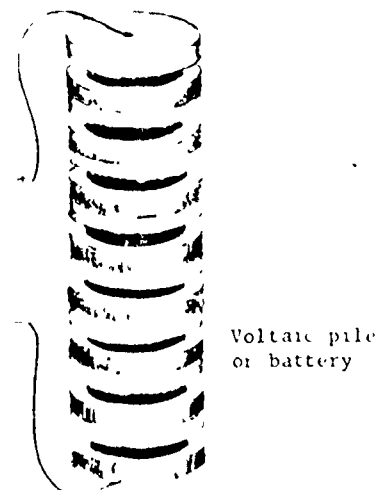
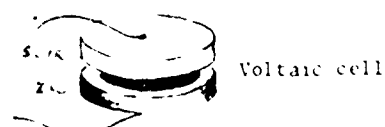

A  $1\frac{1}{2}$ -volt cell is one which has a potential difference of  $1\frac{1}{2}$  volts between its two terminals. (Often called a "battery," although technically a battery is a group of connected cells.)

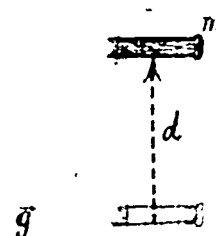

potential energy can be converted into kinetic energy when a charge moves in an electric field. This fact is employed in an electron accelerator like the TV picture tube. When an electron moves through a potential difference of one volt, it increases its kinetic energy by  $1.6 \times 10^{-19}$  joules. This amount of energy is defined as one "electron volt."

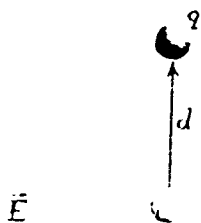

The symbol  $V$  is used both for "potential difference" as in Eq. 14.9, and as abbreviation for volt, the unit of potential difference (as in  $1V = 1 J/coul$ ).

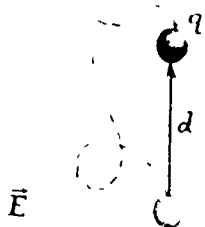

Suppose  $d = 2 \text{ cm}$ ,  
 $E = 300 \text{ N/coul}$ , and  
 $q = 10^{-9} \text{ coul}$ .  
 Then the work done  
 $= (10^{-9} \text{ coul})(300 \text{ N/coul})(.02 \text{ m})$   
 $= 6 \times 10^{-9} \text{ joule}$ .  
 The potential difference  
 $= \frac{6 \times 10^{-9} \text{ joules}}{10^{-9} \text{ coul}}$   
 $= 6 \text{ joules/coul}$ .  
 $= 6 \text{ volts}$

The unit of electric field strength, newtons/coulomb, is equivalent to volts/meter, which is more convenient in many applications. This is pointed out in SG 14.17, and used in SG 14.18 and SG 14.22.

In a similar way, the electric potential energy is defined as the work done when work is done on an electric charge in moving it from one point to another in an electric field. The change in potential energy can be expressed in terms of the magnitude of the charge  $q$  and the potential difference that depends on the electric field and the location of the two points. Electric potential energy is the ratio of the change in electric potential energy to charge to the magnitude of the charge.

$$V = \frac{\Delta(\text{PE})}{q}$$

The units of electric potential difference are the units of energy divided by charge, or joules per coulomb.

The potential difference between two points in an electric field is 1 volt if 1 joule of work is done in moving a unit positive charge from one of the points to the other.

$$1 \text{ volt} = 1 \text{ joule/coulomb}$$

The potential difference between two points in a static electric field depends on the location of the points, but not on the path followed by the test charge. Thus it is possible to speak of the electric potential difference between two points, just as it is possible to speak of the difference in gravitational potential energy between two points.

Let us see how this definition is used in a simple case by calculating the potential difference between two points in an electric field, such as the electric field used in the Millikan experiment. Consider two points in a uniform electric field of magnitude  $E$  produced by oppositely charged parallel plates. The work done moving a positive charge  $q$  from one point to the other is the product of the force  $qE$  exerted on the charge, and the distance  $d$  along the field through which the charge is moved. Thus

$$\Delta(\text{PE}) = qEd.$$

The electrical potential difference, defined above, is

$$V = \frac{\Delta(\text{PE})}{q} = \frac{qEd}{q} = Ed.$$

(Note that the electric potential difference is defined in such a way that it is independent of the magnitude of the charge that is moved.)

Electric potential energy, like gravitational potential energy, can be converted into kinetic energy. A charge placed in an electric field, but free of other forces, will move so as to increase its kinetic energy at the expense of electric potential energy. (In other words, the electric



**14.9 Electric potential difference and current.** The acceleration of an electric field of an electron in a vacuum is the simplest example of the effect of a potential difference on a charged particle. A more familiar example is electric current in a metal wire. Here the relation between motion and potential difference might seem to be more complicated, because electrons in a metal are continually interacting with the atoms of the metal. However, there is a simple relation which is approximately valid in the case of metallic conductors: the total current is proportional to the potential difference:

$$\text{current (I)} \propto \text{potential difference (V)}.$$

This relation is called Ohm's law. It is usually written in the form

$$I = V/R \quad (14.10)$$

where  $R$  is called the resistance. Thus Ohm's law states that the resistance of a given substance does not change appreciably with current or voltage. (It does, however, change with the temperature, length and diameter of the wire.)

Ohm's law is a good empirical approximation, but it does not have the broad applicability of more important laws such as the law of universal gravitation or Coulomb's law. We shall use it mainly in connection with the discussion of electric power and power transmission in Chapter 17.

How does the current in a metallic conductor change if the potential difference between the ends of the conductor is doubled?

**14.10 Electric potential difference and power.** When a battery is connected in an electric circuit, chemical changes inside the battery produce an electric field which charges one terminal negative and one terminal positive. The voltage of the battery is a measure of the work per unit charge done by the electric field in moving charge through any external path from one terminal of the battery to the other. If the charge could move freely from one terminal to the other in an evacuated tube, the work done on the charge would just increase the kinetic energy of the charge. However, if the charge moves through some material, it will transfer energy to the material through collisions: some of the work will go into increasing the internal energy of the material. If, for example, the battery is forcing charges through the filament wire of a flashlight bulb, the electric work done on the charges is dissipated in heating the filament. (The hot filament radiates energy, a small fraction of which is in the form of visible light.)

*Summary 14.9*

According to Ohm's law, the total current is proportional to the potential difference. The law is written  $I = V/R$ , where  $R$  is called the resistance.

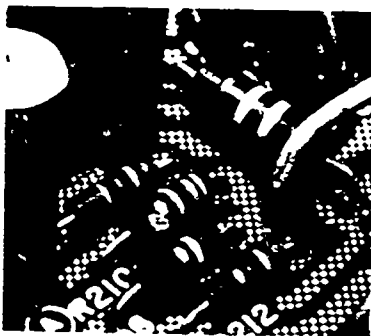

Parts of the electric circuit in the tv set pictured on p. 42. The resistors have nearly constant voltage to current ratios (values of which are indicated by the stripes).

*Summary 14.10*

1. When a steady current flows through a material, most of the work done on the charges is dissipated in heating the material.



A More perfect molecular machines



Recall now that voltage (potential difference) is the amount of work done per unit of charge transferred. Also current is the number of units of charge transferred per unit time. So the product of voltage and current will then be the amount of work done per unit time:

$$V(\text{joules/coulomb}) \cdot I(\text{coulombs/sec}) = VI(\text{joules/sec}).$$

But work done per unit time is called power. The unit of power, equal to 1 joule/sec, is called a "watt." Using the definition of ampere (1 coulomb/sec) and volt (1 joule/coulomb), we can write for the power P:

$$P(\text{watts}) = V(\text{volts}) \cdot I(\text{amperes}). \quad (14.11)$$

What happens to this power? As the charge moves to a lower potential, it does work against the resistance of the material and the electrical energy is converted into heat energy. If  $V$  is the voltage across some material carrying a current  $I$ , the power dissipated as heat will be  $P = VI$ . This can be expressed in terms of the resistance of the material by substituting  $IR$  for  $V$ :

$$\begin{aligned} P &= IR \cdot I \\ P &= I^2 R. \end{aligned} \quad (14.12)$$

Joule was the first to find experimentally that the heat produced by a current is proportional to the square of the current. This discovery was part of his series of researches on conversion of different forms of energy (see Sec. 10.8). The fact that the rate of dissipation of energy is proportional to the square of the current has great significance in making practical use of electric energy, as we will see in the next chapter.

Q19 What happens to the electrical energy used to move charge in a conducting material?

Q20 How does the power dissipated as heat in a conductor change if the current in the conductor is doubled?

**14.11 Currents act on magnets.** Since early in the eighteenth century there were reports that lightning had changed the magnetization of compass needles and had made magnets of knives and spoons. Some believed that they had magnetized steel needles by discharging a Leyden jar through them. These reports suggested that electricity and magnetism are intimately related in some way.

None of these occurrences surprised adherents of the nature philosophy current in Europe at the start of the nineteenth century. They were convinced that all the observed forces of nature were different manifestations of a single force. Their metaphysical belief in the unity of physical

E35\*: Currents and forces

D49: Currents and forces

14.11  
2 The work done per second when the current is one amp and the potential difference is one volt, is 1 joule/sec = 1 watt, in general, the power (in watts) is equal to the product of voltage and current  $P = VI$  (for steady currents).

3 Combining the above expression for power with Ohm's law, we have  $P = I^2 R$ . This expression will be useful in Ch 16, in connection with heat loss in transmission lines.

Example: A small flashlight bulb connected to a 1.5-volt cell will have a current of about 0.1 ampere in its filament. At what rate is electric work being done to heat the filament in the bulb?

$$\begin{aligned} P &= VI \\ &= 1.5 \text{ volts} \times 0.1 \text{ amps} \\ &= 0.15 \text{ watts} \end{aligned}$$

(Only a small fraction of this power goes into the visible light energy radiated from the filament.)

Joule apparently embarked on this program while considering possible conversion of his father's brewery from steam to electrical power

Summary 14.11

1. In 1820, Oersted found that a current exerts force on a magnetic needle; the force is perpendicular to the line from current to magnet.

2. The shape of the magnetic lines of force around a current can be shown with iron filings, the lines of force around a coil of wire are similar to those around a bar magnet.



## Oersted's Discovery



Hans Christian Oersted (1777-1851), a Danish physicist, studied the writings of the nature philosopher Schelling and wrote extensively on philosophical subjects himself. In an essay published in 1813, he predicted that a connection between electricity and magnetism would be found. In 1820 he discovered the circular magnetic field around an electric current by placing a compass under a current-carrying wire. In later years he vigorously denied the suggestion of other scientists that his discovery of electromagnetism was accidental.

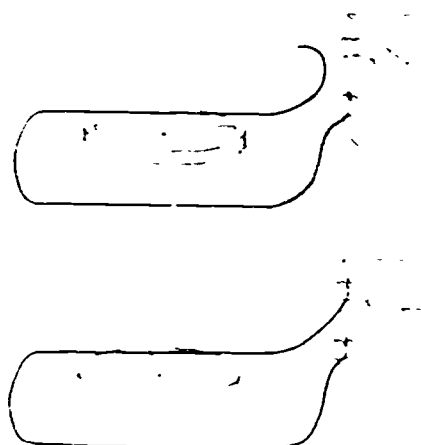

To make the photograph below, a thick wire was inserted through a sheet of cardboard and tiny slivers of iron were sprinkled on the sheet. A strong current through the wire creates a magnetic field which causes the slivers to become magnetized and to line up in the direction of the field.

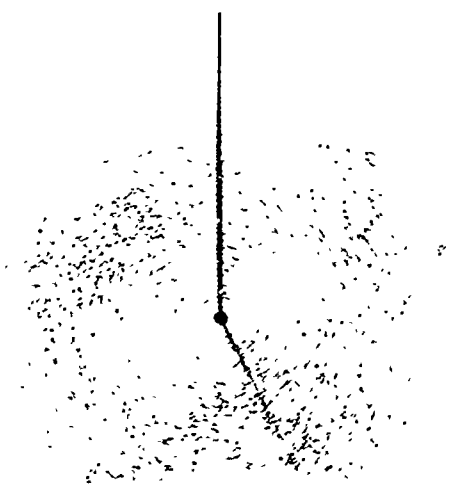

An array of tiny compasses on a sheet of cardboard placed perpendicular to a brass rod. When there is a strong current in the rod, the compass needles line up along the magnetic field of the current and indicate that the lines of force are circular around the rod.

forces would, in fact, lead them to expect that electric and magnetic forces were associated in some way.

The first concrete evidence of a connection between electricity and magnetism came in 1820, when Oersted performed a famous series of experiments. Oersted placed a thin wire carrying a current directly beneath a long horizontal magnetic needle. He had placed the wire along the earth's magnetic north-south line, so that the magnetic needle was aligned parallel to the wire. When the wire was connected to the terminals of a battery, the magnetic needle went to a new orientation—perpendicular to the wire! While Oersted at first did not expect a magnet, change in position of a current) was exert a strange kind of "sideways" force on a magnet.

See "Oersted" in Articles section

Oersted's results were the first instance in which a force was observed that did not act along a line connecting the sources of the force. The force that the current-carrying wire exerts on a magnetic pole is not along the line from the wire to the pole; the force on the pole is perpendicular to this line. The magnetic needle is not attracted to the wire by the current; it is twisted around by force on it.

Thus, a current affects a compass needle certainly, and it is no wonder it had taken so long before anyone found the connection between electricity and magnetism. Oersted's experiment revealed more clearly what was happening. The long straight current-carrying wire turns a small magnet so that the north-south line on the magnet is tangent to a circle that has its center at the wire and lies in a plane perpendicular to the wire. In other words, the current produces a circular force field, not a central force field.

Compass needles are deflected in the region near a current, because the current produces a magnetic field there. We can get a clue to the "shape" of the magnetic field by sprinkling tiny slivers of iron which serve as tiny compass needles on a sheet of paper through which the current-carrying wire is passing. We define the direction of the magnetic field at a point to be the same as the direction of the force on the north-seeking pole of a tiny compass needle at that point.

It is a little hard to see the direction of the force on a tiny compass needle at a point in the region near a current-carrying wire. The force on the north-seeking pole of a tiny compass needle is perpendicular to the line from the wire to the pole. The force on the south-seeking pole is perpendicular to the line from the wire to the pole, but in the opposite direction. The force on the north-seeking pole is perpendicular to the line from the wire to the pole, and the force on the south-seeking pole is perpendicular to the line from the wire to the pole, but in the opposite direction.



A series of diagrams illustrating the magnetic field around a current-carrying wire. The top diagram shows a wire with current flowing to the right and a magnetic needle deflected. The middle diagram shows a top-down view of the wire with circular magnetic field lines around it, indicated by arrows and the symbol B. The bottom diagram shows a side view of the wire with a vertical magnetic field vector B pointing upwards.

A Force law for bar magnets

### Summary 14.12

1. Ampère, hearing of Oersted's discovery, reasoned that currents should act on currents, he then discovered and thoroughly investigated experimentally the forces between currents.

2. The unit of current, the ampère, is officially defined in terms of magnetic forces between current-carrying wires.



André-Marie Ampère (1775-1836) was born in a village near Lyons, France. There was no school in the village and Ampère was entirely self-taught. His father was executed during the French Revolution, and Ampère's entire personal life seems to have been affected by his father's death. Ampère became a professor of mathematics in Paris and made important contributions to physics, mathematics, and the philosophy of science. His self-portrait is reproduced above.

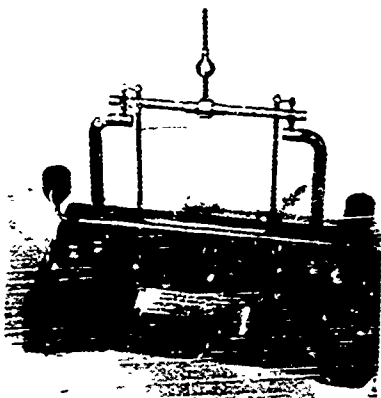

A. Who's who in TV

show this, instead of using a long straight wire going through a hole in the paper as above, we bend the wire into a loop so that it goes through the paper in two places. The magnetic effects of the different parts of the wire on the iron sliver combine to produce a field pattern similar to that of a bar magnet.

12. Under what conditions can electric charges affect magnets?

13. What was surprising about the force a current exerted on a magnet?

14. How do we know that a current has a magnetic field around it?

**14.12 Currents act on currents.** Oersted's discovery opened up an exciting new subject of research. Soon, scores of people in laboratories throughout Europe and America began intensive studies on the magnetic effects of electric currents. The work of Andre-Marie Ampère (1775-1836) stands out among all the rest. Ampère came to be called the "Newton of electricity" by James Clerk Maxwell, who some decades later was to construct a complete theory of electricity and magnetism. Ampère's work is filled with elegant mathematics, which we cannot detail. But we can trace some of his ideas and review some of his experiments.

Ampère's thoughts began racing forward as soon as he heard Oersted's news. He began with a line of thought somewhat as follows: since magnets exert forces on each other, and since magnets and currents also exert forces on each other, can it be that currents exert forces on other currents? Although it is tempting to leap forward with a reply, the answer is not obvious. Ampère recognized the need to let experiment provide the answer. He wrote:

When...M. Oersted discovered the action which a current exercises on a magnet, one might certainly have suspected the existence of a mutual action between two circuits carrying currents; but this was not a necessary consequence; for a bar of soft iron also acts on a magnetised needle, although there is not mutual action between two bars of soft iron.

And so Ampère put his hunch to the test. On September 30, 1820, within a week after word of Oersted's work reached France, Ampère reported to the French Academy of Science that he had found that two current-carrying wires exert forces on each other.

...the force which each wire exerts on the other is directly proportional to the product of the currents in the two wires, and inversely proportional to the distance between them.

current. In the laboratory you can repeat some of these experiments and work out the force law. We will not need to go into the quantitative details here, except to note that the force between currents is now used to define the unit of current, which is called the ampere (as mentioned in Sec. 14.3). One ampere is the amount of current in each of two long straight parallel wires, one meter apart, which causes a force of  $2 \cdot 10^{-7}$  newtons on each meter of wire.

14.2. What was Ampere's hunch?

#### Electrical units (summary)

The ampere is the fourth fundamental unit in the so-called MKSA system (meter, kilogram, second, ampere) which is now widely used by physicists.

The coulomb is defined as the amount of charge that flows in one second, when the current is 1 ampere.

The volt is defined as the potential difference between two points such that 1 joule of work is done in moving 1 coulomb of charge between those points.

The watt is defined as the amount of energy flow per second (or work done per second, or "power") which corresponds to 1 joule per second. Thus a current of 1 ampere due to a potential difference of 1 volt corresponds to 1 watt of power.

The kilowatt is equal to 1000 watts.

The kilowatt-hour is the amount of work done when one kilowatt of power is used for one hour. It is equal to 3,600,000 joules (1000 joules/sec  $\times$  3600 sec).

The ohm is defined as the resistance of a material which allows a current of just 1 ampere if the potential difference is 1 volt.

**14.13 Magnetic fields and moving charges.** In the last two sections we discussed the interactions of currents with magnets and with each other. The analysis of these phenomena is greatly simplified by the use of the concept of magnetic field.

Electrically charged bodies exert forces on each other. When the charged bodies are at rest, we say that the forces are "electric" forces and imagine "electric fields" which are responsible for them. When the charged bodies are moving, new forces appear in addition to the electric forces. We call these new forces "magnetic" and attribute them to "magnetic fields."

The magnetic interaction of charged bodies is not as simple as the electric interaction, since it depends on the speeds and relative directions of motion of the bodies as well as their distance apart. As in the description of Faraday's experiment, the direction of the force exerted by a current

2 In general when a charge moves through a magnetic field the force on the charge tends to make it move in a circular or oval path

#### 132 Magnetic fields and moving charges

(The numerical factor of  $2 \times 10^{-7}$  was chosen, somewhat arbitrarily, in order to get a unit of convenient size for practical use.)

The MKSA unit of magnetic field is defined as a field that produces a force of one newton on a charge of one coulomb moving at right angles to the direction of  $\vec{B}$  with velocity of one meter per second. This magnetic field unit is known as the tesla, in honor of the Yugoslavian electrical engineer Nikola Tesla. (The tesla is identical to the weber meter<sup>2</sup>.)

Many physicists persist in using CGS units where the unit of  $\vec{B}$  is the gauss (1 tesla =  $10^4$  gauss)

In modern physics the magnetic field strength is given the symbol  $\vec{B}$ , and is defined in terms of the force exerted on a charge moving through the magnetic field.

#### Summary 14.13

1 When a charge  $q$  moves with speed  $v$  in a direction perpendicular to a magnetic field  $\vec{B}$ , the magnitude of the force on the charge is  $F = qvB$ . The direction of the force is always perpendicular both to the direction of the field and to the direction of motion of the charge

## Magnets and Fields

The diagrams at the right represent the magnetic field of a current in a loop of wire. In the first diagram, some lines of force due to opposite sides of the loops have been drawn separately. One example is given of how the two fields add at point P. Some lines of force for the total field are drawn in the second diagram. Below at the right is a photograph of iron filings in the magnetic field of an actual current loop. Below at the left is the field of a series of coils, or helix.

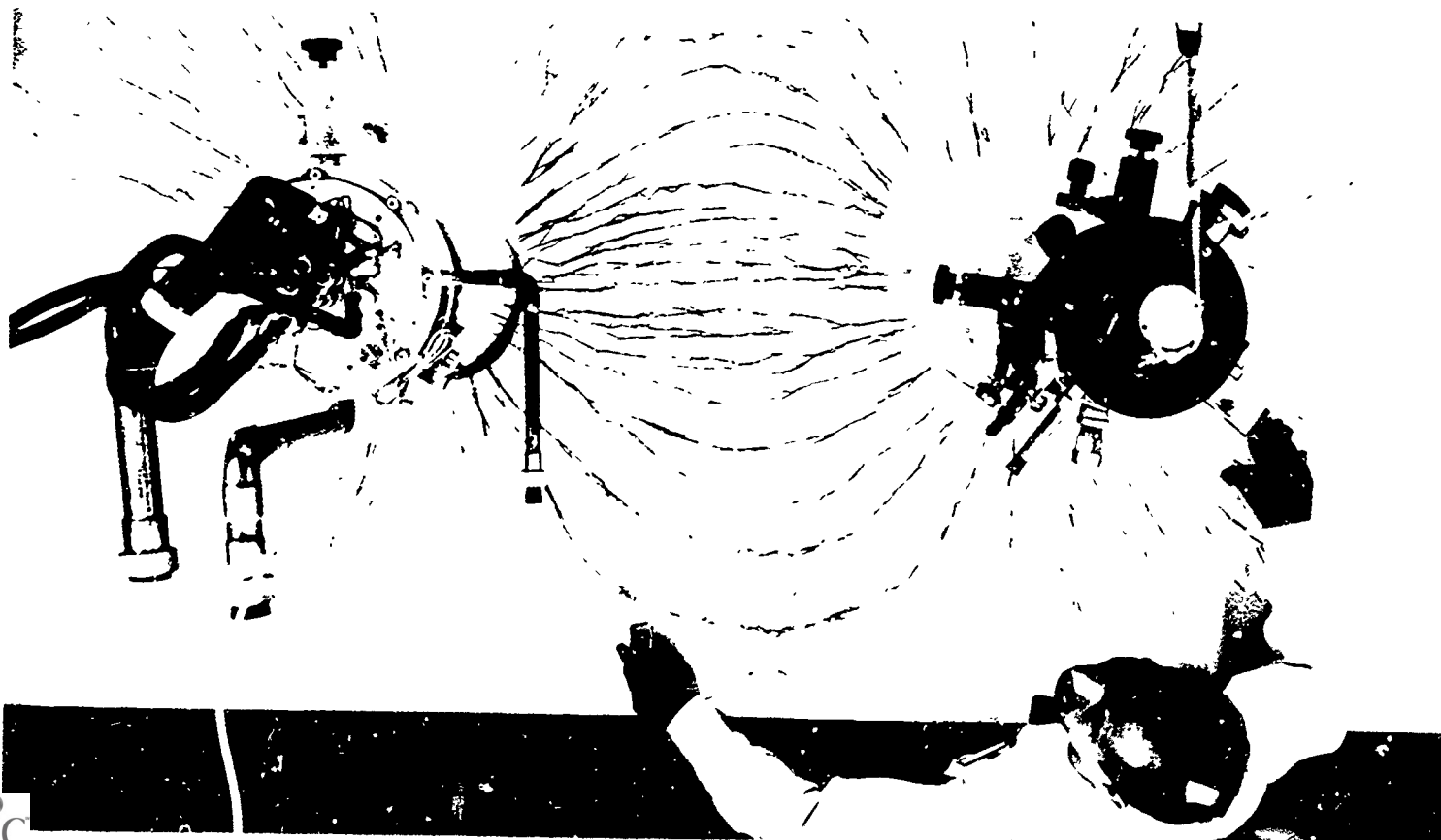
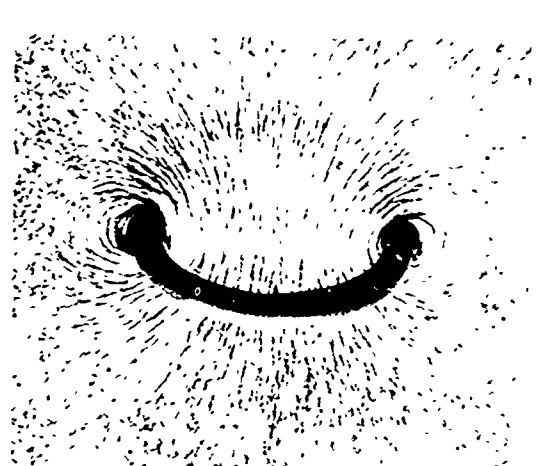
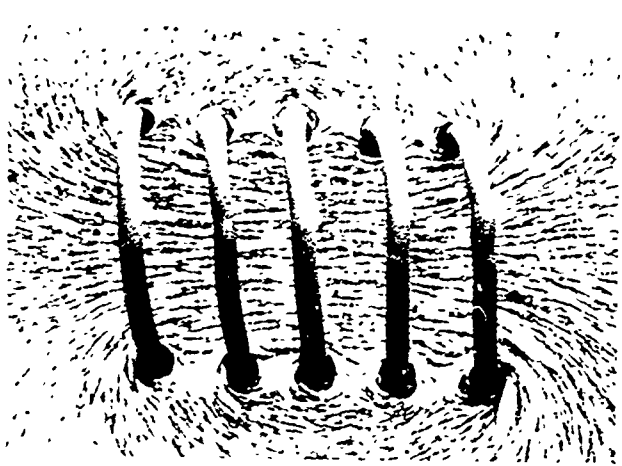

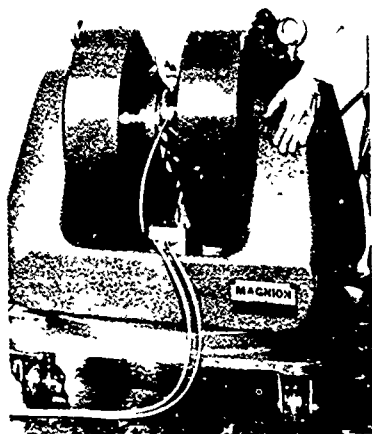

Modern electromagnet used in research when strong, uniform fields are required.

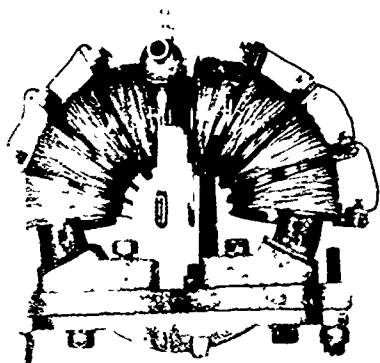

This electromagnet was used early in this century to deflect a beam of charged atoms. It appears again in Unit 6.

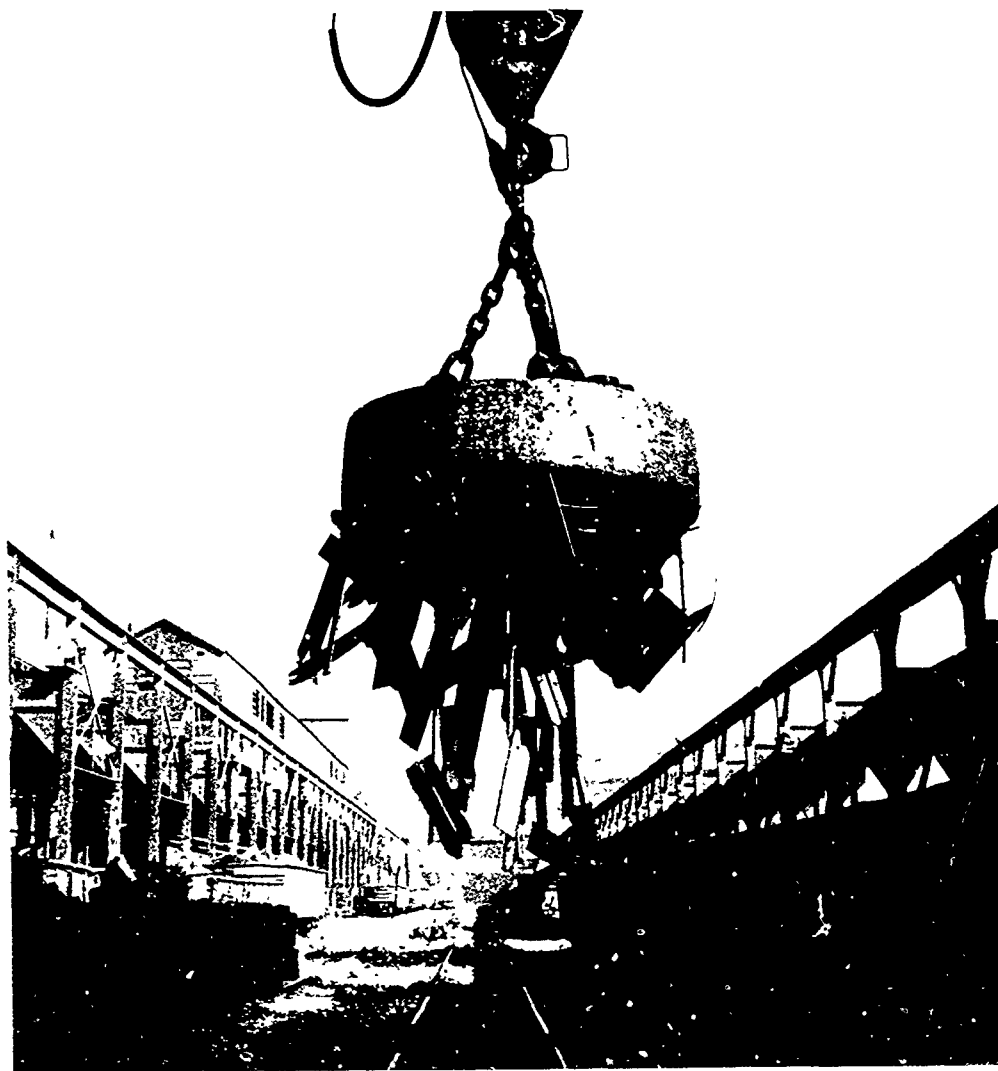

In many applications, from doorbells to cyclotrons, magnetic fields are produced by coils of wire around iron cores. The iron core becomes magnetized and increases the strength of the field by a factor of 10 or 100. Such devices are called electromagnets.

The first electromagnet, invented by William Sturgeon in England in 1824, could lift a weight of nine pounds. In 1832, Joseph Henry constructed an electromagnet at Princeton which could hold up a weight of 3,600 pounds. Modern electromagnets which can lift 40,000 or 50,000 pounds of iron are widely used in industry.

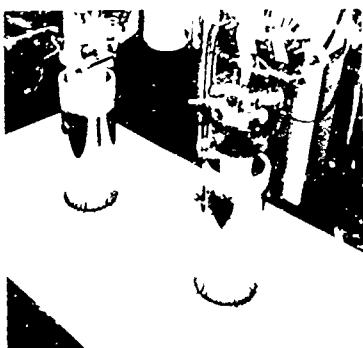
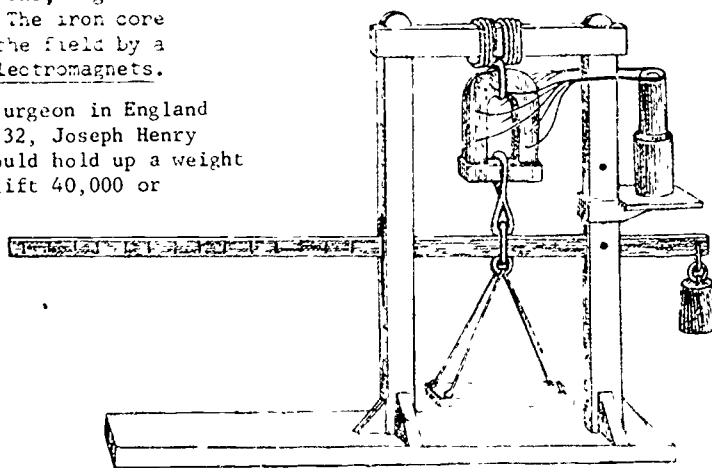

In the two pictures at the left, iron nails line up in a strong magnetic field produced by large currents in superconducting coils kept at 4° above absolute zero.

Copyright © 1964 by ERIC  
Full Text Provided by ERIC

B

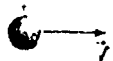

B



B



A useful rule: if your fingers point along  $\vec{B}$ , and your thumb along  $\vec{v}$ ,  $\vec{F}$  will be in the direction your palm would push. For pos. charges use the right hand, and for neg. use the left hand.

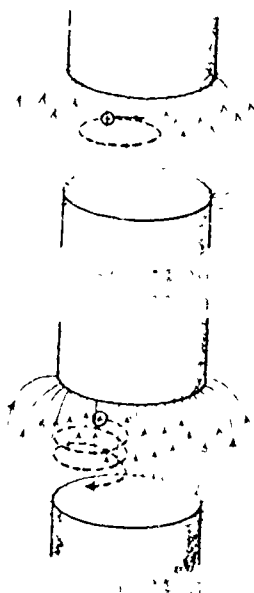
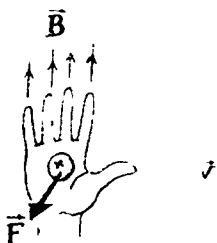

on a magnet is perpendicular both to the direction of the current and to the line between the magnet and current.

Suppose we have a magnetic field  $\vec{B}$  which may be produced either by a magnet or a current, and study how this field acts on a moving charge. The force on the charge depends on three quantities: the magnitude of the charge, the velocity of the charge and the strength of the field. If the charge is moving in a direction perpendicular to the field, the magnitude of the force is proportional to each of these quantities:

$$F \propto qvB$$

If the charge is moving in a direction parallel to  $\vec{B}$ , there is no force. For other directions of motion, the force is proportional to the component of the velocity perpendicular to the field direction,  $v_{\perp}$ . The direction of the force is always perpendicular both to the direction of the field and to the direction of motion of the charge.

The force exerted by a magnetic field on a moving charged particle can be used to define the unit of magnetic field, by taking the proportionality constant equal to one. This definition will be convenient here since we will be mainly concerned with magnetic fields as they interact with moving charges (rather than with forces between magnets). In the case when  $\vec{B}$  and  $\vec{v}$  are at right angles to each other, the magnitude of the force becomes

$$F = qvB. \tag{14.13}$$

The path of a charged body in a magnetic field. The magnetic force on a moving charged body is always "off to the side," that is, perpendicular to its direction of motion. Therefore, the magnetic force does not change the speed of the charged body, but it does change its velocity. If a charged body is moving exactly perpendicular to a uniform magnetic field, there will be a constant sideways push and the body will move along a circular path.

What happens if the charged body's velocity has some component along the direction of the field but is not exactly parallel to it? The body will still be deflected into a curved path, but the components of its motion along the field will continue undisturbed; so the particle will trace out a coiled path (see sketch). If the body moves directly along the direction of the field or directly against it, there is no force.

Some important examples of the deflection of charged particles by magnetic fields will be discussed in units 15 and 16.

A Measuring magnetic field intensity  
 A Additional activities using the electron beam tube

E37: Electron beam tube



Here we will mention one very important example of the "coiled" motion: the Van Allen radiation belts. A stream of charged particles, mainly from the sun but also from outer space, continually sweeps past the earth. Many of these particles are deflected into spiral paths by the magnetic field of the earth, and are subsequently "trapped." The extensive zones containing the rapidly moving trapped particles are called the Van Allen belts. Some of the particles which escape from these radiation zones are deflected toward the earth's magnetic poles where they hit the atmosphere and cause the aurora ("northern lights" and "southern lights").

So far we have been discussing the interaction between currents and magnets and between magnetic fields and charged particles. These interactions have important consequences for society as well as for physics, as we shall see in the next chapter.

- 10.5 Which of the following affect the magnitude of the magnetic force on a moving charged particle?
- the component of the velocity parallel to the field
  - the component of the velocity perpendicular to the field
  - the magnetic field  $\vec{B}$
  - the magnitude of the charge
  - the sign of the charge

10.6 Which of the items in the preceding question affect the direction of the magnetic force on the charged particle?

10.7 Why does the magnetic force on a moving charged particle not change the speed of the particle?

James A. Van Allen (b. 1914) is an Iowa-born physicist who heads the group that designed the instruments carried by the first American satellite, Explorer I. The zones of high energy particles detected by these instruments are discussed in an article by Van Allen, "Radiation Belts Around the Earth" in Project Physics Reader 4.

*This is only a simplified sketch. The actual field is very distorted by the solar wind, as in the drawing on p. 73*

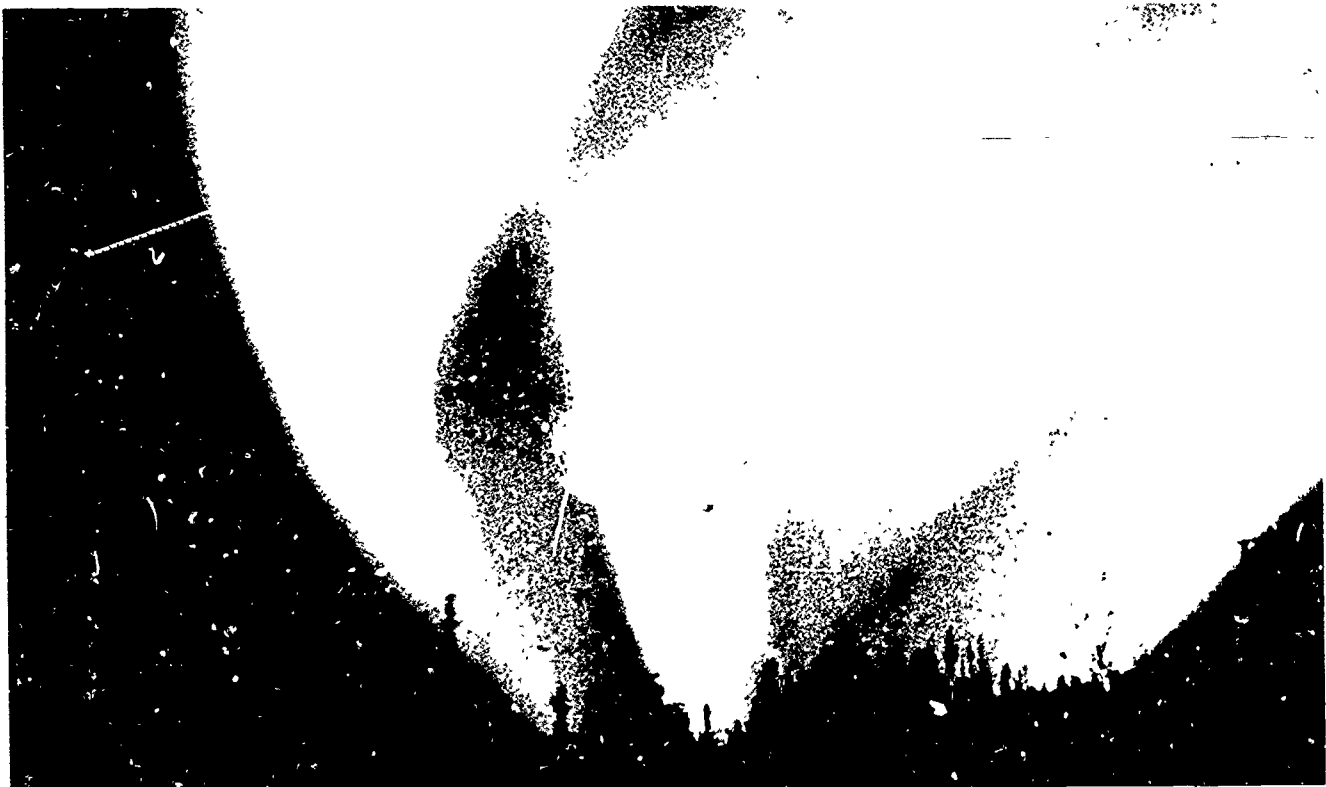
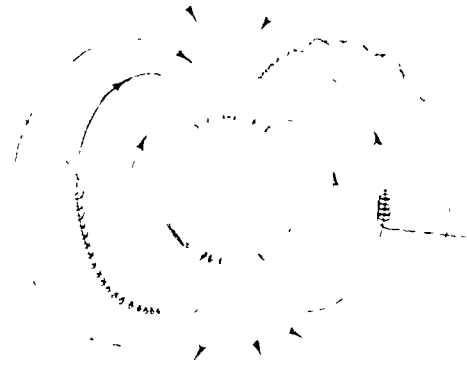

Charge shift in neutral body brings some charge closer to charged body

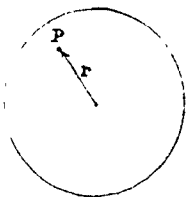

- 14.1 How much must you alter the distance between two charged objects in order to keep the force on them constant if you
- triple the net charge on each? *Tripled*
  - halve the net charge on each? *Halved*
  - double the net charge on one and halve the net charge on the other? *Keep distance the same*
- 14.2 How far apart in air must two charged spheres be placed, each having a net charge of 1 coulomb, so that the force on them is 1 newton?  *$9.5 \times 10^4 \text{ m}$  or  $95 \text{ km}$*
- 14.3 If electrostatic induction doesn't involve the addition or subtraction of charged particles, but instead is just the separation, or redistribution, of charged particles, how can you explain the fact that attraction results from induction?
- 14.4 An aluminum-painted ping-pong ball hanging by a nylon thread from a ring stand is touched with a finger to remove any slight charge it may have had. Then a negatively charged rod is brought up close to but not touching the ball. While the rod is held there the ball is momentarily touched with a finger; then the rod is removed. Does the ball now have a net charge? If you think *Yes*, it has, make a few simple sketches to show how it became charged, indicating clearly what kind of charge it has been left with. *positive*
- 14.5
- Calculate the strength of the gravitational field of the moon at a point on its surface. The mass of the moon is  $7.3 \times 10^{22} \text{ kg}$  and its radius is  $1.74 \times 10^6 \text{ m}$ .  *$16 \text{ N/Kg}$*
  - Calculate the gravitational field at a point near the surface of a small but extremely dense star, LP357-18b, whose radius is  $1.5 \times 10^6 \text{ m}$  and whose density is  $10^4 \text{ kg/m}^3$ .  *$4.1 \times 10^9 \text{ N/Kg}$*
  - The gravitational field of a uniform spherical shell is zero inside the shell. Use this principle together with Newton's gravitational force law and the formula for the volume of a sphere ( $\frac{4}{3} r^3$ ) to find out how the gravitational field at a point P inside a planet depends on the distance of P from the center. (Assume the planet's density is uniform throughout.)  *$g_r \sim r$*
- 14.6 We speak of an electric field exerting a force on a charged particle placed in the field. What has to be true about this situation in view of the fact that Newton's third law holds in this case, too? *Reaction to field, then to source*
- 14.7 The three spheres A, B and C are fixed in the positions shown. Determine the direction of the net electrical force on sphere C which is positively charged if
- spheres A and B carry equal positive charges. *Right*
  - spheres A and B have charges of equal magnitude but the charge on B is negative, and A is positive. *Down*
- 14.8 There is an electric field strength at the earth's surface of about  $100 \text{ N/coul}$ , directed downward.
- What is the total charge of the earth? (As Newton showed for gravitational forces, the field of a uniform sphere can be calculated by assuming all of the charge is concentrated at the center.)  *$10^6 \text{ coulombs}$*
  - Actually, because the earth is a conductor, most of the charge is on the surface. What, roughly, is the average amount of charge per square meter of surface? Does this seem large or small, compared to familiar static charges like those on combs, etc.?  *$10^{-9} \text{ coulombs/m}^2$ ; fairly small*
- 14.9 In oscilloscope tubes, a beam of electrons is deflected by two pairs of oppositely charged plates. Each pair of plates, as can be seen in the photograph on the next page, is shaped something like the sketch in the margin. Sketch in roughly what you think the electric field between a pair of such plates would be like.

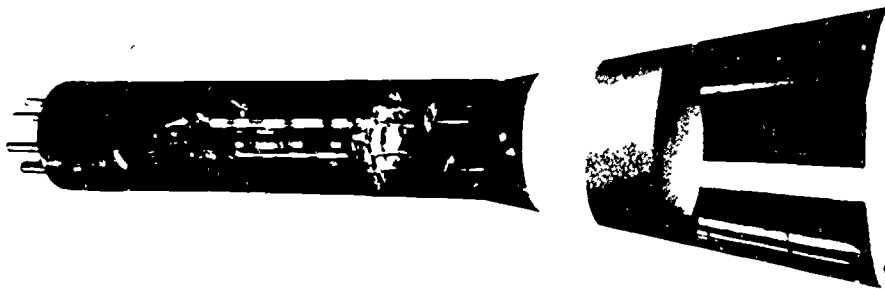

- 14.10 Is air friction on the oil drop a help or a hindrance in the experiment described for measurement of the charge of the electron? Explain your answer briefly. *A help*
- 14.11 The magnitude of the electron charge is  $1.6 \times 10^{-19}$  coulomb. *6.25 x 10<sup>18</sup> electrons*  
How many electrons are required to make 1 coulomb of charge?
- 14.12 Calculate the ratio of the electrostatic force to the gravitational force between two electrons a distance of  $10^{-10}$  meter apart. (The mass of the electron is approximately  $10^{-30}$  kg; recall that  $G = 6.7 \times 10^{-11}$  N·m/kg<sup>2</sup>.) *3.4 x 10<sup>42</sup>*
- 14.13 Because electrical forces are similar in some respects to gravitational forces, it is reasonable to imagine a charged particle, such as the electron, moving in an orbit around another charged particle. Then, just as the earth is a "gravitational satellite" of the sun, the electron would be an "electric satellite" of some positively charged particle with a mass so large compared to the electron that it can be assumed to be stationary. Suppose the particle has a charge equal in magnitude to the charge of the electron, and that the electron moves around it in a circular orbit.
- The centripetal force acting on the moving electron is provided by the electrical force between the electron and positively charged particle. Write an equation representing this statement, and from this equation derive another equation that shows how the kinetic energy of the electron is related to its distance from the positively charged particle.  *$\frac{1}{2}mv^2 = \frac{1}{2}kq^2/R$   
 $1.2 \times 10^{-18}$  J*
  - Calculate what the kinetic energy of the electron would be if the radius of its orbit were  $10^{-10}$  meters.\*
  - What would be the speed of the electron if it had the kinetic energy you calculated in part (b)? (The mass of the electron is approximately  $10^{-30}$  kg.)  *$1.5 \times 10^6$  m/sec*
- \*The value given here, perhaps you suspect, is appropriate to an electron circling an atomic nucleus (as will be discussed in detail in Unit 5).
- 14.14 A hard-rubber or plastic comb stroked through the hair can often be shown to be charged. Why does a metal comb not readily show a net charge produced by combing or rubbing? *Charge leaks off onto your hand.*
- 14.15 What is the potential difference between two points if  $6 \times 10^{-4}$  joules of work were done against electric forces in moving  $2 \times 10^{-5}$  coulombs of charge from one point to the other? *30 volts*
- 14.16 If there is no potential difference between any points in a region, what must be true of the electric field in that region? *zero*
- 14.17 Electric field intensity can be measured in either of two equivalent units: newtons-per-coulomb and volts-per-meter. Using the definitions of volt and joule, show that N/coul is actually the same as V/m. Can you explain the equivalence in words? *Work = qEd  
V = Work/q = Ed  
E = V/d*
- 14.18 If the distance between the surfaces of two conducting spheres is about 1 cm, an electric potential difference of about 30,000 volts between them is required to produce a spark.
- What is the minimum electric field strength (in the gap between the surfaces) necessary to cause sparking?  *$3 \times 10^6$  volt/m*
  - The gap between the two electrodes in an automobile sparkplug is about 1 mm (39 thousandths of an inch). If the voltage produced across them by the ignition coil is about 10,000 volts, what is the electric field strength in the gap?  *$10^7$  volt/m*
- 

- 14.19 An electric battery "pumps" charges onto its terminals until the electric potential difference between the terminals reaches a certain value; usually the value is very close to the voltage marked on the battery. What would happen if we connected two or more batteries in series?

For example, the battery on the right below maintains terminal C at a potential level 6 volts higher than terminal D. The battery on the left maintains terminal A at a potential 6 volts higher than terminal B. If we connect B to C with a good conductor, so that B and C are at the same potential level, what is the potential difference between A and D?

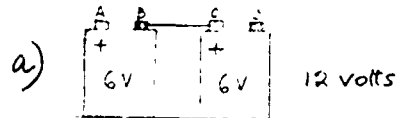

What would the potential difference be between the extreme left and right terminals in the following set-ups?

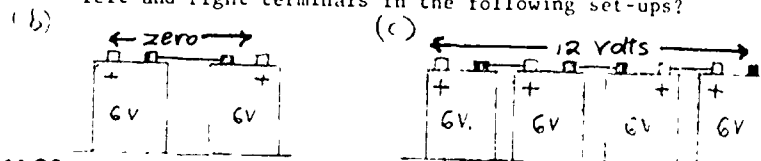

- 14.20 a) What kinetic energy will an electron gain in an evacuated tube if it is accelerated through a potential difference of 100 volts. State your answer in electron volts and also in joules. *100 eV or  $1.6 \times 10^{-17} \text{ J}$*   
 b) What speed will it acquire due to the acceleration? (The mass of the electron is  $10^{-31} \text{ kg}$ .)  *$5.6 \times 10^6 \text{ m/sec}$*

- 14.21 Suppose various metallic resistors are connected to a battery and to a current meter. The following table gives two of three quantities related by Ohm's law for three separate cases. Complete the table.

If a potential difference of 1 volt results in a current of 1 ampere, the resistance is defined to be 1 ohm.

	Voltage	Current	Resistance
a)	2 volts	<i>4 amps</i>	0.5 ohms
b)	10 volts	2 amps	<i>5 ohms</i>
c)	<i>15 volts</i>	3 amps	5 ohms

- 14.22 The electric field at the earth's surface can increase to about  $10^4$  volts/meter under thunder clouds.  
 a) About how large a potential difference between ground and cloud does that imply?  *$10^7$  volts for a cloud  $10^3 \text{ m}$  up.*  
 b) A set of lightning strokes can transfer as much as 50 coulombs of charge. Roughly how much energy would be released in such a discharge?  *$5 \times 10^8 \text{ J}$ , (using  $10^7$  volts)*



Three "guns" are mounted side by side to produce three charge beams in a color tv tube. Charges emitted from hot wires just inside the left end of the guns are accelerated from one cylindrical electrode to the next and emerge from the guns toward the screen with almost exactly the same energy.

- 14.23 "Physics International's  $B^2$  Pulsed Radiation Facility is now producing the world's most intense electron beam (40,000 amps/4 MeV) as a routine operation. With this beam PI can precisely deposit upwards of 5,000 joules of energy in 30 nanoseconds." (Physics Today, Dec. 1966)

The "4 MeV" means that the charges in the beam have an energy that would result from being accelerated across a potential difference of 4 million volts. A "nanosecond" is a billionth of a second. Are these published values consistent with regard to the power of the beam?

*Not exactly consistent, but not unreasonable.*

- 14.24 If the beam in a TV tube constitutes a current on the order of  $10^{-3}$  amps, roughly what is the power of the picture? *20 watts*

14.25 Calculate the power dissipated for each of the three parts of question 14.21. *8W, 20W, 45W*

14.26 A student who wished to show the magnetic effect of a current on a pocket compass, slowly slid the compass along the table top toward a wire lying on the table and carrying a constant current. He was surprised and puzzled by the lack of any noticeable turning effect! How would you explain to him what is wrong with his experiment, or with his expectation of the outcome?

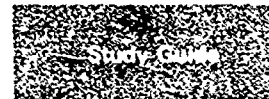

wire is east-west, so its field parallels earth's.

14.27 The sketch shows two long, parallel wires, lying in a vertical north-south plane (the view here is toward the west). A horizontal compass is located 10 cm below the upper wire. With no current in the wires, the needle points N. With 1 amp in the upper wire, the needle points NW.

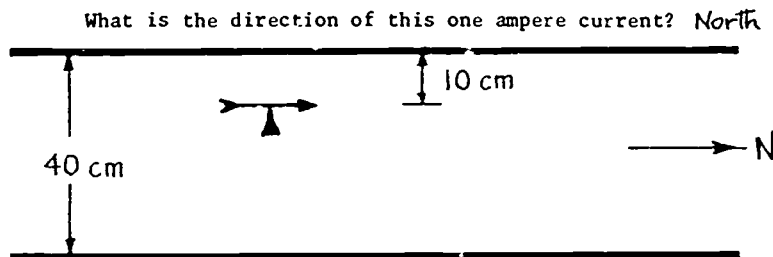

14.28 What current (magnitude and direction) in the lower wire would restore the compass needle to its original position? (Use the results of Experiments 35 and 36.) *3 amps North*

14.29 The magnetic force on a charged particle moving perpendicularly to a uniform magnetic field is directed toward a single point—the center of the circular path the particle will follow.

$$qvB = \frac{mv^2}{R}; R = \frac{mv}{qB};$$

- a) Knowing that the magnetic force (given by  $qvB$ ) provides the centripetal force (given by  $mv^2/R$ ), show that the radius of the circle is directly proportional to the momentum of the particle.  $\therefore R \sim mv$
- b) What information would you need to determine the <sup>ratio</sup> of the particle's charge to its mass? *Speed (v), B, and R*

14.30 By referring to the information given in the last problem, find an equation for the period of the circular path.  $T = \frac{2\pi m}{qB}$

14.31 In the margin is a sketch of a positively charged particle moving in a very non-uniform magnetic field.

- a) Show mathematically that the radius of the spiral path will be smaller where the field strength is greater.  $R = \frac{mv}{qB}$
- b) Use the right hand rule to show that the direction of the magnetic force is such as to partially oppose the movement of the particle into the region of stronger field.

14.32 If the energy of charged particles approaching the earth is very great, they will not be trapped in the Van Allen belts, but just deflected, continuing on past or into the earth. The direction of the earth's magnetic field is toward its north end. If you set up a detector for positively charged particles, would you expect to detect more particles by directing it slightly toward the east or slightly toward the west? *West*

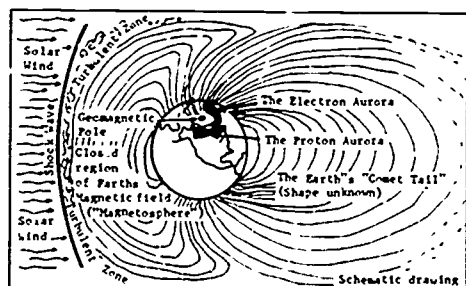
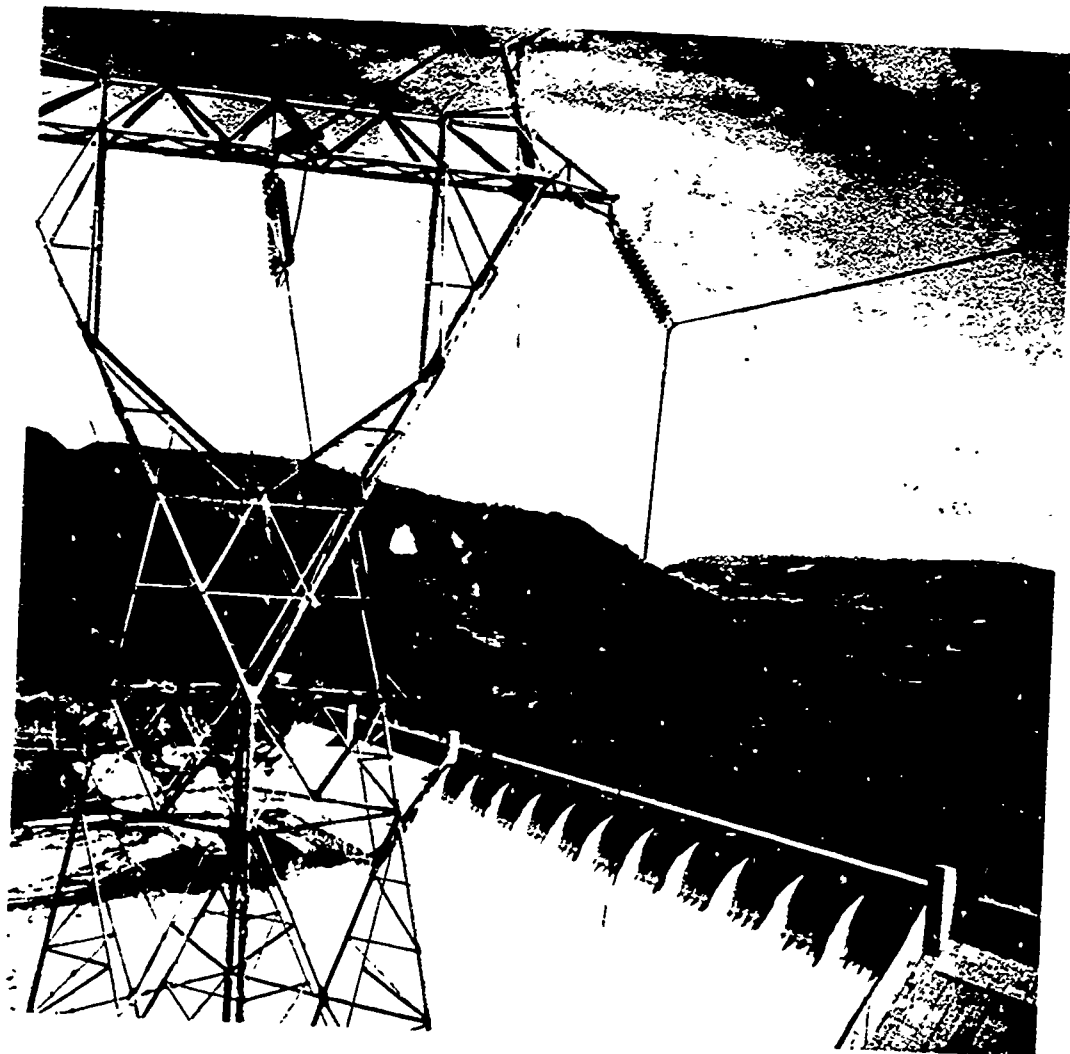

Diagram of the magnetic field of the earth distorted by a "wind" of electric charges streaming out from the sun. (New York Times, September 11, 1966)

## Chapter 15 Faraday and the Electrical Age

Section		Page
15.1	The problem: getting energy from one place to another	75
15.2	Clue to the solution: electromagnetism	75
15.3	Faraday's early work on electricity and lines of force	76
15.4	The discovery of electromagnetic induction	79
15.5	Generating electricity from magnetism: the dynamo	83
15.6	The electric motor	86
15.7	The electric light bulb	89
15.8	Ac versus dc in the Niagara Falls power plant	93
15.9	Electricity and society	100*

\*Pages 95-99 adapted from H. I. Sharlin's book, The Making of the Electrical Age.





**15.1 The problem: getting energy from one place to another.** In Chapter 10 we discussed the development of the steam engine, in the eighteenth and nineteenth centuries, which enabled Europe and America to make use of the vast stores of energy contained in coal, wood and oil. By burning fuel one can convert chemical energy into heat energy. Then, by using this heat energy to make steam and letting the steam expand against a piston or a turbine vane, one can get mechanical energy. In this way one can use the steam engine to move large weights or turn cranks to run machinery.

But steam engines suffered from a major defect: the mechanical energy was available only at the place where the steam engine was located, and practical steam engines had to be big, hot and dirty. In order to use machines run by steam engines, people had to crowd together in factories. It was possible to use steam engines for transportation by making locomotives, which were astonishing and powerful but also limited by their size and weight, not to speak of soot.

A better power system would have one central power plant from which energy could be sent out, for use at a distance, by machines of any desired size and power at the most useful locations.

After Volta's invention of the battery (Chapter 14), many scientists guessed that electricity might provide a means of transporting energy and running machines. But batteries quickly lost their power and provided only a very feeble current. A better way of generating electrical currents was needed. When this was found, it changed the whole shape of life at home and in factories, and it changed also the very appearance of cities and landscapes.

In this chapter we will see how discoveries in basic physics gave rise to new technologies—technologies which have revolutionized modern civilization.

**15.2 Clue to the solution: electromagnetism.** The first clue came from Oersted's discovery that a magnetic needle is deflected by a current. Suppose we make the very reasonable assumption that Newton's third law applies to electrical and magnetic forces. Then if a current can exert a force on a magnet, we expect that a magnet should also exert a force on a current. Going beyond what Newton's third law says to a more general idea of symmetry, we might even speculate that a magnet can somehow produce a current.

Scientists and inventors in both Europe and America quickly realized that there were important—and perhaps profitable—

### Summary 15.1

The steam engine provided a good source of energy but the energy could not easily be made available where it was needed. Electricity might solve the problem if a better way of generating currents could be found.

A: Physics collage

### Summary 15.2

Oersted's discovery that a magnetic needle is deflected by a current suggested that a magnet might be used to generate current, and so stimulated much research on the interactions of electricity and magnetism.



### Summary 15.3

1 In 1821, Faraday repeated Oersted's experiment and got the idea that the current-carrying wire is surrounded by "circular lines of force" which act on the magnetic needle

2 Faraday invented the first electric motor, in which a magnet moved in a circle around a current (or conversely).

3 Ampère, contrary to Faraday, believed that forces must act directly between particles of matter (as in Newton's theory of gravity) He could not accept the idea of a "circular force" in space.

4. Ampère assumed that magnets are composed of microscopic current loops; thus magnetic forces could be reduced to forces between currents, and "circular forces" could apparently be avoided.

5. Faraday's intuitive idea of lines of force, though at first unacceptable to mathematical physicists accustomed to Newtonian-type forces, ultimately became the basis for Maxwell's electromagnetic theory.

A: The lodestone, the magnet

DS1: Electric fields

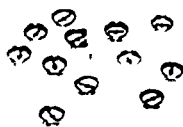

discoveries waiting to be made in electromagnetism. Within a few months after the news of Oersted's discovery reached Paris, the French physicists Biot, Savart and Ampère had begun a program of quantitative research on the interactions of electricity and magnetism. (Some of their results were mentioned in Sec. 14.8.) In Germany, Seebeck found that a current could magnetize a steel needle. In England, Davy and Wollaston tried unsuccessfully to make a wire revolve around its own axis by bringing a magnet close to it. Other experiments and speculations on electromagnetism, too numerous to mention, were soon reported in the scientific journals. Yet the one crucial discovery—the generation of a continuous electric current—still eluded these eminent and brilliant men.

Faraday's early work on electricity and lines of force. A valuable function of scientific journals is to provide for their readers comprehensive survey articles on recent advances in science, as well as the usual terse announcements of the technical details of discoveries. The need for a review article is especially great after a large burst of activity such as that which followed Oersted's discovery of electromagnetism in 1820.

In 1821 the editor of the British journal Annals of Philosophy asked Michael Faraday to undertake a historical survey of the experiments and theories of electromagnetism which had appeared in the previous year. Faraday, who was at that time an assistant to the well-known chemist Humphry Davy, did not yet have a reputation in science but was eager to learn all he could. Faraday agreed to accept the assignment, but soon found that he could not limit himself to merely reporting what others had done. He had to repeat the experiments in his own laboratory, and, not being satisfied with the theoretical explanations proposed by other physicists, started to work out his own theories and plans for further experiments. Before long Faraday, who had originally been apprenticed to a bookbinder and had no formal training in science or mathematics, had launched a series of researches in electricity that was to make him one of the most famous physicists of his time.

Faraday's first discovery in electromagnetism was made on September 3, 1821. Repeating Oersted's experiment by holding a compass needle at various places around a current-carrying wire, Faraday realized that the force exerted by the current on the magnet is circular in nature. As he expressed it a few years later, the wire is surrounded by circular lines of

force, so that a magnetic pole which is free to move will be pushed in a circle around a fixed wire (see the discussion of lines of force in Chapter 14). Faraday immediately constructed an "electromagnetic rotator" based on this idea. It worked. Faraday had invented the first electric motor!

Faraday also designed an arrangement in which the magnet was fixed and the current-carrying wire rotated around it. (If a current can exert a force on a magnet, a magnet should be able to exert an equal and opposite force on a current, according to Newton's third law.) As in many other cases, Faraday was guided by the idea that for every effect of electricity on magnetism, there must be a converse effect of magnetism on electricity. But it was not always so obvious what form the converse effect would take.

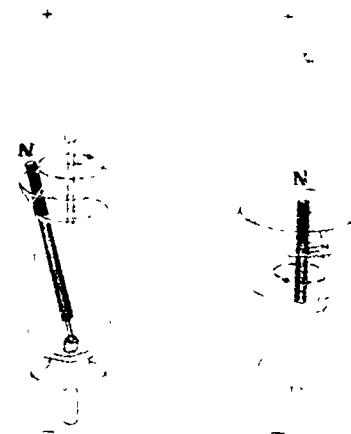
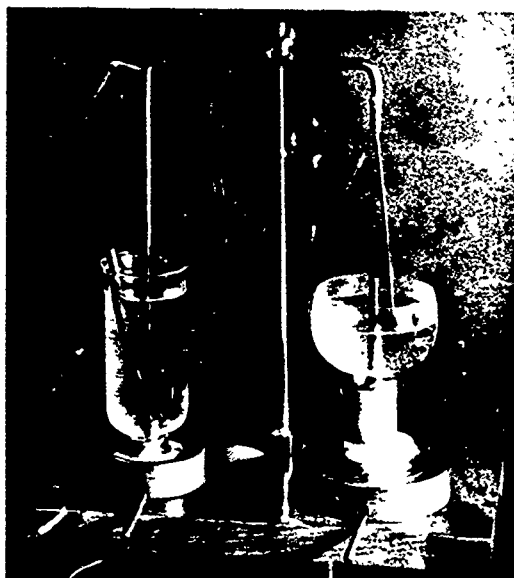

Two versions of Faraday's electromagnetic rotator. In each, the cup was filled with mercury so that a large electric current can be passed between the base and overhead support. At the left, the north end of a bar magnet revolves along the circular electric lines of force surrounding the current. At the right, the rod carrying the current revolves around the bar magnet—moving always perpendicular to the magnetic lines of force.

After Faraday's paper describing electromagnetic rotation was published, Ampère criticized it on theoretical grounds. To understand the reasons for this criticism (and for the failure of many contemporary physicists to accept Faraday's theories) we must recall that the Newtonian viewpoint was still dominant in European science at this time. Not only did almost all scientists accept Newton's laws of motion as the basis for mechanics, they also believed that all forces in nature must somehow be similar to the Newtonian gravitational force. That is, forces must act directly between particles of matter in a direction along the line between the centers of the particles. They need not be attractive forces in all cases, and they need not even be inversely proportional to the square of the distance between the particles. Newton himself had proposed other kinds of forces; for example, repulsive forces inversely proportional to the distance between neighboring particles in a gas (see Chapter 11). However, no one had ever supposed that forces could act in any direction other than the direction along the line between the particles. Yet here was Faraday proposing a "circular" force; that is, a force exerted by a current on a magnet which acted in a direction at right angles to the line between them.

*Note, however, that nothing in Newton's laws would preclude a non-central force, it just makes conservation of momentum harder to figure out if such forces exist.*

Faraday, despite his ignorance of Newtonian mathematical physics, seemed to have the experimental facts on his side. Anyone could see that the magnet did actually rotate around the current (or the current around the magnet). Why not simply assume that a circular force causes this motion?

Ampère could not accept the idea of a circular force. Instead, he argued that all the interactions of electricity and magnetism can be reduced theoretically to interactions between individual parts, or "elements," of current-carrying wires. Just as in Newton's theory of gravitational force, the forces between current elements must act in the direction along the line between the elements.

How could such a theory explain the forces exerted by magnets, or on magnets? Ampère had noticed that a current would orient iron filings into a pattern in much the same way as would a magnet. In particular, a long wire wrapped into a tight coil, or "helix," had all the properties of a bar magnet, the coil's "poles" being at its ends. Ampère therefore made the bold assumption that the attractive and repulsive forces between magnets are the result of electric currents circulating within the magnets themselves. In this way he could treat a magnet as if it were made up of current elements. What seemed to be a circular force was really, according to Ampère, the total effect produced by a large number of direct forces between current elements.

Ampère proposed that a magnet consisted of a large number of microscopic current loops. These currents cancelled each other everywhere but at the surface, so that the net effect was the same as a coil of wire.

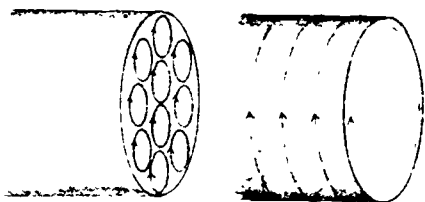

Field of a wire coil

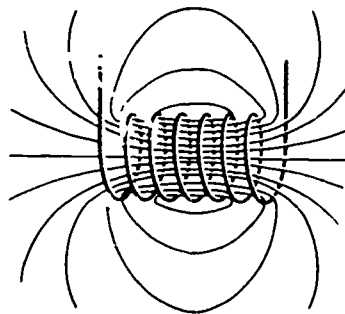

Field of a bar magnet

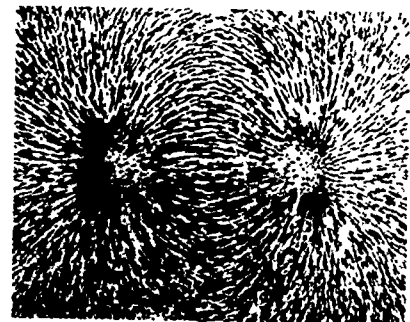

The present view of magnetic materials is something like Ampère's (but much more detailed and complex). The "current loops" are of atomic dimensions, with electron orbits and spin. As a result, they don't die out as any current loops would (except in superconductors). Very complicated effects result from the interaction of the atoms with each other and with external magnetic fields.

Ampère preferred his explanation of electromagnetic interactions because it could be expressed mathematically with the equations familiar in Newtonian physics. Faraday, on the other hand, did not understand much mathematics, but he did have an amazing intuitive feeling for physical phenomena. In most instances where mathematics has conflicted with intuition in the history of physics, mathematics has eventually won out. (The success of Galileo and Newton in developing the laws of motion is a good example.) But in this case, Faraday's nonmathematical approach gained at least a temporary

victory for intuition. Faraday's idea of electric and magnetic "lines of force" led him to make important discoveries in electromagnetism—discoveries that the mathematical physicists were prevented from making by their Newtonian prejudices. Not until 1855, when another brilliant mathematical physicist, James Clerk Maxwell, took the trouble to figure out what Faraday meant by a line of force, was it possible to see how Faraday's ideas might be incorporated into the framework of Newtonian physics. (We will discuss this work of Maxwell on the "electromagnetic field" in Chapter 16.)

Q1 Why is the magnetic pole of Faraday's "electromagnetic rotator" pushed in a circle around a fixed wire?

Q2 What did Ampère assume caused the forces between magnets?

**15.4 The discovery of electromagnetic induction.** Armed with his "lines of force" picture for understanding electric and magnetic fields, Faraday joined in the search for a way of producing currents by magnetism. Scattered through his diary in the years after 1824 are many descriptions of such experiments. Each report ended with a note: "exhibited no action" or "no effect."

Finally, in 1831, came the breakthrough. Like many discoveries which have been preceded by a period of preliminary research and discussion among scientists, this one was made almost simultaneously by two scientists working independently in different countries. Faraday was not quite the first to produce electricity from magnetism; that was actually done first by an American scientist, Joseph Henry. Henry was teaching mathematics and philosophy at an academy in Albany, New York, at the time. (Shortly thereafter he was appointed Professor of Natural Philosophy at Princeton.) Unfortunately for the reputation of American science, teachers at the Albany Academy were expected to spend all their time on teaching and administrative duties, with no time left for research. Henry had hardly any opportunity to follow up his discovery, which he made during a one-month summer vacation. He was not able to publish his work until a year later, and in the meantime Faraday had made a similar discovery and published his results.

Faraday is known as the discoverer of "electromagnetic induction" (production of a current by magnetism) not simply because he established official priority by first publication, but primarily because he conducted exhaustive investigations into all aspects of the subject. His earlier experiments and his thinking about lines of force had suggested the possibility that a current in one wire ought to be able to induce a

#### Summary 15.4

1 In 1831, Henry in America and Faraday in England independently discovered electromagnetic induction (generation of currents using magnets, or induction of one current by another).

2. Faraday found that a current in one wire could induce a current in a nearby wire only when the first current is changing. A steady current cannot induce a current in another wire.

3. Faraday reasoned that the induction of one current by another was due to the action of the magnetic field around the first current, hence the iron ring around which the wire was wound in his original experiment was not necessary, but simply intensified an effect that would occur anyway. He confirmed this reasoning by showing that current could also be induced when no iron ring was used.

4. Faraday also reasoned that the presence of the first current was unnecessary: a current could be induced merely by moving a magnet relative to a wire. He confirmed this by experiment.

5. Faraday finally showed that a steady current could be generated by continually moving a conductor across a strong magnetic field. But he did not himself follow up the practical applications of his discovery.



Michael Faraday (1791-1867) was the son of an English blacksmith. In his own words,

My education was of the most ordinary description consisting of little more than the rudiments of reading, writing and arithmetic at a common day school. My hours out of school were passed at home and in the streets

At the age of twelve he went to work as an errand boy at a bookseller's store. Later he became a bookbinder's assistant. When Faraday was about nineteen he was given a ticket to attend a series of lectures given by Sir Humphrey Davy at the Royal Institution in London. The Royal Institution was an important center of research and education in science, and Davy was Superintendent of the Institution. Faraday became strongly interested in science and undertook the study of chemistry by himself. In 1813, he applied to Davy for a job at the Royal Institution and Davy hired him as a research assistant. Faraday soon showed his genius as an experimenter. He made important contributions to chemistry, magnetism, electricity and light, and eventually succeeded Davy as superintendent of the Royal Institution. Because of his many discoveries, Faraday is generally regarded as one of the greatest of all experimental scientists. Faraday was also a fine lecturer and had an extraordinary gift for explaining the results of scientific research to non-scientists. His lectures to audiences of young people are still delightful to read. Two of them, "On the Various Forces of Nature" and "The Chemical History of a Candle," have been republished in paperback editions. Faraday was a modest, gentle and deeply religious man. Although he received many international scientific honors he had no wish to be knighted, preferring to remain without the title of "Sir."

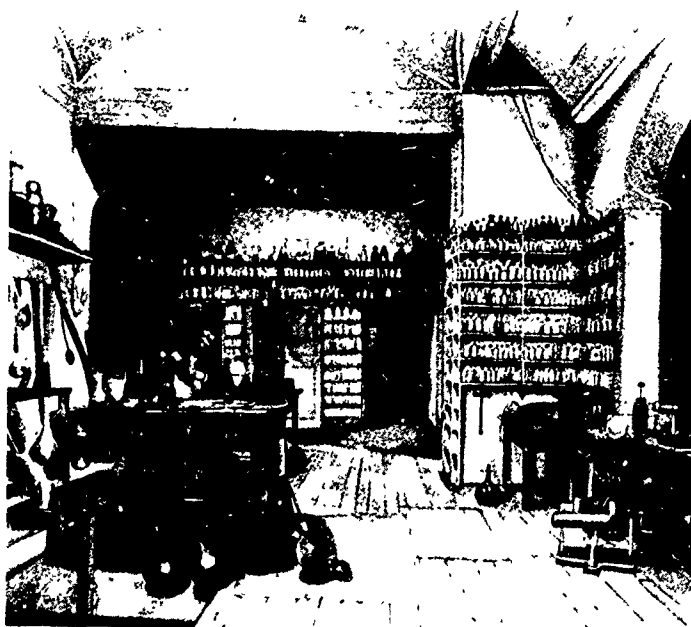

Faraday's laboratory at the Royal Institution.



current in a nearby wire. The induction might take place directly between small sections of current, as a consequence of the force studied by Ampère (Sec. 14.8). Or it might be that the magnetic lines of force in the space around the first current could produce a current in the other wire.

How does electromagnetic induction take place? Oersted and Ampère had shown that a steady electric current produced a steady magnetic effect around the circuit carrying the current. One might think that a steady electric current could somehow be generated if a wire were placed near or around a magnet, although a very strong magnet might be needed. Or a steady current might be produced in one circuit if a very large current flows in another circuit nearby. Faraday tried all these possibilities, with no success.

Finally, in 1831, Faraday found the solution. He discovered that a current appeared in one wire only when the current in the other wire started or stopped! When a current started to flow in one wire, a current was indeed induced in the second wire, but it lasted only for a moment. As long as there was a steady current in the first wire, there was no current in the second wire; but when the current in the first wire was stopped, again there was a momentary current induced in the second wire.

To summarize Faraday's result: a current can induce another current only by changing. A steady current in one wire cannot induce a current in another wire.

Faraday was not satisfied with merely observing and reporting this result. Guided by his concept of "lines of force," he tried to find out what were the essential factors involved in electromagnetic induction, as distinguished from the accidental circumstances of his first experiment.

According to Faraday's theory, the changing current in the primary coil (A) would change the lines of magnetic force in the iron ring, and the change in magnetic lines of force in the part of the ring near the secondary coil (B) would induce a current in the secondary coil. But if this was really the correct explanation of induction, Faraday asked himself, shouldn't it be possible to produce the same effect in another way? In particular:

(1) is the iron ring really necessary to produce the induction effect, or does it merely intensify an effect that would occur anyway whenever magnetic lines of force are present in space?

(2) is the primary coil really necessary, or could current



The page in Faraday's diary where he recorded the first successful experiment in electromagnetic induction, August 29, 1831. (About 1/3 actual size)

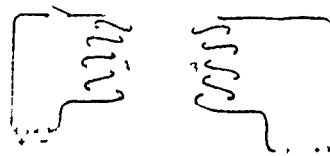

be induced merely by changing magnetic lines of force in some other way, such as by moving a magnet relative to the wire?

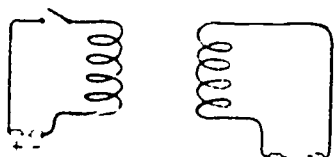

Faraday answered these questions almost immediately by further experiments. First, he showed that the iron ring was not necessary; starting a current in one coil of wire would induce a momentary current in a nearby coil. Second, he found that when a bar magnet was inserted into the end of a coil of wire, a current was induced at the instant of insertion. In Faraday's words,

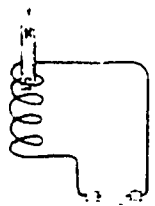

A cylindrical bar magnet...had one end just inserted into the end of the helix cylinder; then it was quickly thrust in the whole length and the galvanometer needle moved; then pulled out and again the needle moved, but in the opposite direction. The effect was repeated every time the magnet was put in or out....

Having done these and many other experiments, Faraday stated his general principle of electromagnetic induction: changing lines of magnetic force can cause a current in a wire. The "change" in lines of force can be produced either by (a) a magnet moving relative to a wire or (b) a changing current. (Faraday found it convenient to speak of wires "cutting across" lines of force.) He later used the word field to refer to the arrangement and intensity of lines of force in space. We can say, then, that a current is induced in a circuit by variations in the magnetic field around the circuit. Such a variation may be caused either by relative motion of wire and field or just by the change in intensity of the field.

So far Faraday had been able to produce only momentary surges of current by induction. Is it possible to produce a steady current by electromagnetic induction? To do this one has to create a situation in which magnetic lines of force are always changing relative to the conductor. (The relative change can be produced either by moving the magnet or by moving the conductor.) This is just what Faraday did: he turned a copper disc between the poles of a magnet. A steady current was produced in a circuit connected to the disc through brass brushes. This device, called the "Faraday disc dynamo," was the first electric current generator. Although this particular arrangement did not turn out to be very practical, at least it showed that continuous generation of electricity was possible.

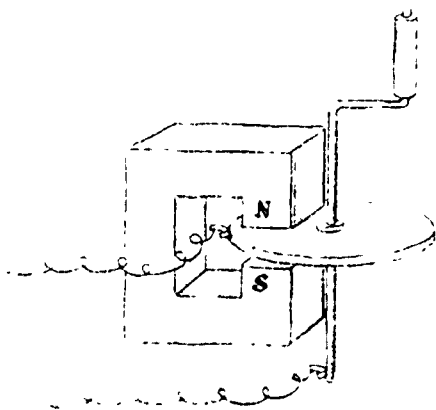

The production of a continuous current was important not only for the understanding of the connection between electricity and magnetism; it also brought with it the possibility of producing electricity on a large scale. The production

*A: Faraday disc dynamo*



of electricity involves changing energy from one form to another. In the voltaic cell (Chapter 14) chemical energy—the energy of formation of chemical compounds—is converted into electrical energy. But it is not practical to produce large amounts of electrical energy by this means, although voltaic cells are useful for many portable applications; automobiles and flashlights for example. Since there is a vast supply of mechanical energy available to produce electrical energy on a large scale, some means of converting mechanical energy into electrical energy is needed. This mechanical energy may be in the form of the potential energy of water at high elevation; or it may be in the form of continuous mechanical motion produced, for example, by a steam engine. The discovery of electromagnetic induction showed that it was feasible to produce electricity by mechanical means. In this sense Faraday can rightly be regarded as the father of the modern electrical age.

Although Faraday realized the practical importance of his discoveries, his primary interest was always in pure science. He left the development of the generator and the motor to others. On the other hand, the inventors and engineers who were interested in the practical and profitable applications of electricity did not know much about physics, and most of the progress during the next fifty years was made by trial and error. In following the development of modern electrical technology, we will see several problems that could have been solved much earlier if a physicist with Faraday's knowledge had been working on them.

Q3 What did Henry and Faraday discover independently but at almost the same time?

Q4 What in general is meant by "electromagnetic induction?"

Q5 What did Faraday find necessary for a current to induce another?

Q6 What was the first electric current generator?

**15.5 Generating electricity from magnetism: the dynamo.** Faraday had shown that when a conducting wire moves through a magnetic field, a current is produced. Whether it is the wire or the magnetic field that moves doesn't matter; what counts is the relative motion. Once the principle of electromagnetic induction had been discovered, the path was open to try all kinds of combinations of wires and moving magnets, magnets and moving wires, and so forth. We shall pass over the details of most of these technical developments and simply describe one basic type of generator (or "dynamo") which was frequently used in the nineteenth century.

A. Generator jump-rope

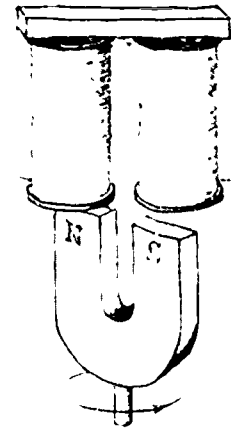

One generator of 1832 had a permanent horseshoe magnet rotated by hand beneath two stationary coils.

A switch attached to the rotating shaft reversed connection each half-cycle, so that this device produced a dc output current. 83

T32: Magnetic fields and moving charges

## A Bicycle generator

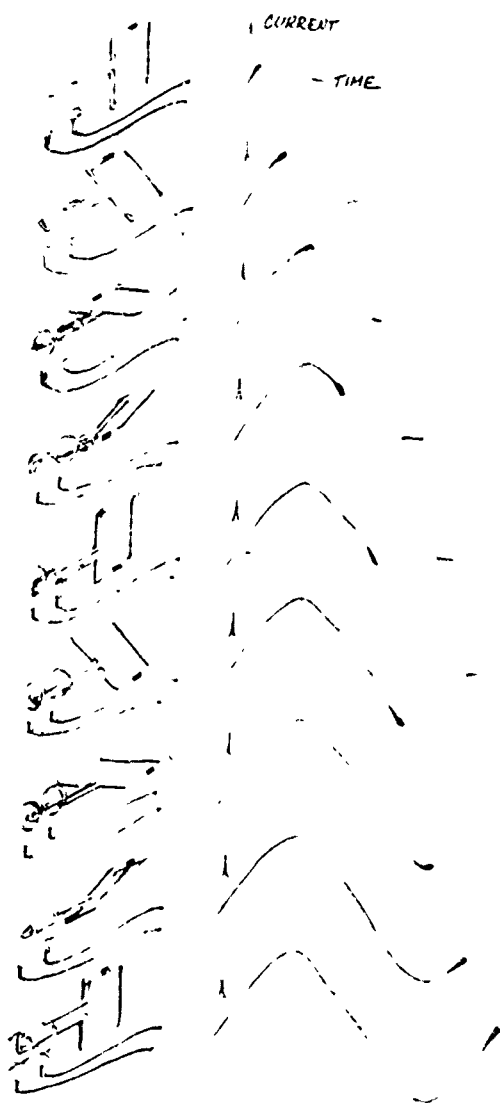
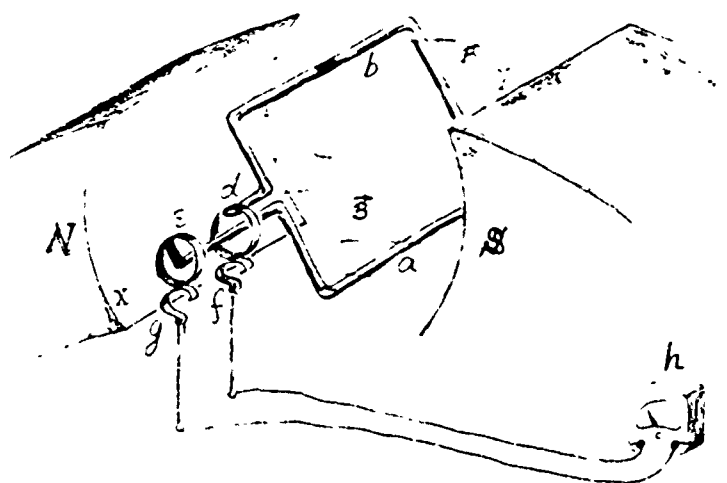

This form of generator is basically a coil of wire rotated in a magnetic field. The rotating coil is connected to an external circuit by sliding contacts. In the diagram on the left a rectangular loop of wire, with long sides a and b, is rotated around an axis XY between the north and south poles of a magnet. Two conducting rings d and e are connected to the loop, and also rotate around the axis; conducting brushes f and g are provided to complete a circuit through a meter at h that indicates the current produced. The complete circuit is abdfhgea. (Note that the wire goes from a through ring d without touching it and connects to e.)

Initially the loop is at rest, and no charge flows through it. Now suppose we start to rotate the loop. The wire will have a component of its motion perpendicular to the direction of the magnetic lines of force; that is, the wire "cuts" through lines of force. This means that an electric current will be induced in the loop. This induction is just the experimental fact discovered by Faraday and Henry.

Because the charges in the part of the loop labeled b are being moved across the magnetic field, they experience a magnetic force given by  $qvB$  (see Sec. 14.13). The charges in the wire will be pushed "off to the side" by the magnetic field that is moving past them; "off to the side" this time is along the wire.

What about a? That side of the loop is also moving through the field and "cutting" lines of force, but in the opposite direction. So the charges in a are pushed in the opposite direction along the wire to those in b. This is just what is needed; the two effects reinforce each other in generating a current around the loop.

The generator we have just described produces what is called alternating current, because the current periodically reverses its direction. At the time this kind of generator was first developed, in the 1830's, alternating current could not be used to run machines. Instead, direct current was desired.

In 1832, Ampère announced that his instrument-maker, Hippolyte Pixii, had solved the problem of generating direct current. Pixii invented a device called the commutator (the word means to interchange, or to go back and forth). The commutator is a split cylinder inserted in the circuit so that the brushes f and g, instead of always being connected to the same part of the loop, reverse connections each time the loop passes through the vertical position. Just as the direction of current induced in the loop reverses, the contacts reverse: as a result, the current in the outside circuit is always in the same direction.

Although the current from Pixii's generator is always in the same direction, it is not constant but fluctuates rapidly between zero and its maximum value. This fluctuating current produces fluctuating magnetic fields which prevent the smooth operation of the generator and waste energy. The generator can be greatly improved by adding many loops and commutators in such a way that their induced currents have maximum and zero values at different times; the total current is then more uniform.

What is the position of the rotating loop for maximum current? minimum?

What is the purpose of the commutator?

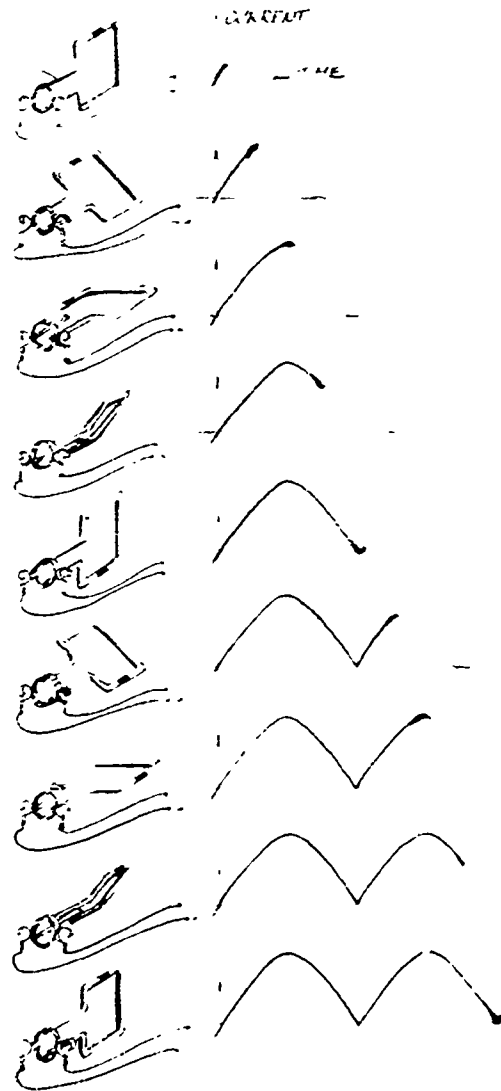
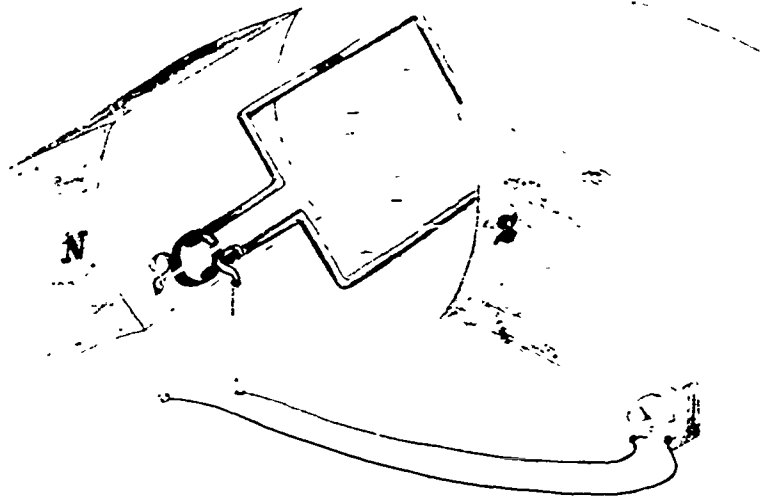

15.6 The electric motor. An electric motor is basically just a generator run "backwards." For example, if the meter h in the circuit sketched at the top of page 84 were replaced by a battery, current would be driven around the circuit. The current in the coil would interact with the magnetic field of the magnet, and the coil would be forced to rotate.

Motors could have been made before generators, and in fact they were. In 1821, Michael Faraday exhibited his electro-magnetic rotator (described in Sec. 15.3) at the Royal Institution in London. Other electric motors were designed by various scientists in Europe and America. One of them was Joseph Henry's "rocking electromagnet." Henry wrote as follows about his motor:

*It isn't hard to figure out how this works. (G and F are, of course, electric cells.)*

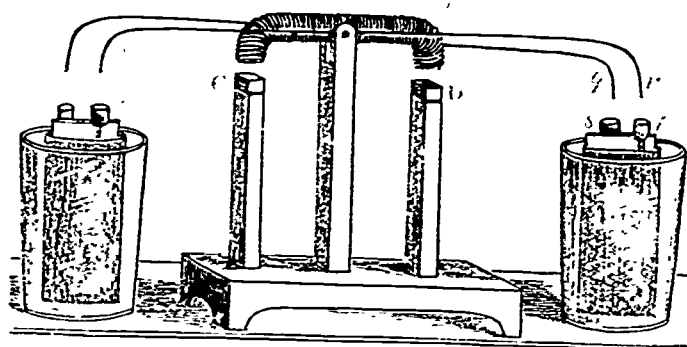

Henry's electromagnetic motor (1831)

T32: Magnetic fields and moving charges

A: Simple motor-generator demonstration

*Summary 15.6*

*Although electric motors had been constructed by Faraday in 1821, and later by Henry and other scientists and inventors, they were not commercially successful until the 1870s. The turning point was the accidental discovery, in 1873, that a generator could be run backwards as a motor.*

I have lately succeeded in producing motion in a little machine by a power, which, I believe, has never before been applied in mechanics—by magnetic attraction and repulsion.

Not much importance, however, is attached to the invention, since the article in its present state can only be considered a philosophical toy; although in the progress of discovery and invention, it is not impossible that the same principle, or some modification of it on a more extended scale, may hereafter be applied to some useful purpose.

The reason for Henry's failure to be very enthusiastic about the importance of his invention is that as long as electric current was only available from batteries, electric motors could not compete with steam engines. The economics of the situation was summarized in a leading British scientific journal as follows:

[Notwithstanding] the numerous attempts which have been made to apply electro-magnetism as a power for moving machines...and the large amount of money which has been expended in the construction of machines, the public are not in possession of any electro-magnetic machine which is capable of exerting any power economically.... Estimations made by Messrs. Scoresby and Joule, and the results obtained by Oersted, ...very nearly agree; and it was stated that one gr. of coal consumed in the furnace of a Cornish [steam] engine lifted 143 lbs. 1 foot high, whereas one gr. of zinc consumed in a battery lifted only 80 lbs. The cost of [one hundred weight] of coal is under 9 pence, and cost of [one hundred weight] of zinc is above 216 pence. Therefore under the most perfect conditions, magnetic power must be nearly 25 times more expensive than steam power... the attention of engineers and experimentalists should be turned at present, not to contriving of perfect machines for applying electro-magnetic power but to the discovery of the most effectual means of disengaging the power itself from the conditions in which it existed stored up in nature. (Philosophical Magazine, 1850)

The dynamo, invented by Faraday and Henry in 1832, was no more economical at first than the battery. It was only another "philosophical toy." Electric generators that could produce power cheaply enough to be commercially successful were not developed until nearly 50 years later. The intervening period was one of numerous inventions that aroused great temporary enthusiasm and ambitious plans, followed by disillusion resulting from unanticipated practical difficulties. But the hope of a fortune to be made by providing cheap power to the world spurred on each new generation of inventors, and knowledge about the physics and technology of electromagnetic systems gradually accumulated.

It is convenient though rarely accurate to ascribe the beginnings of an era to one man, in one place, performing one act, at one time. In reality, with many men thinking about and experimenting in a particular scientific field, the situation becomes favorable for a breakthrough, and only a seemingly trivial chance event may be needed to get things going.

The chance event that marks the beginning of the electric power age was an accidental discovery at the Vienna Exhibition of 1873. As the story goes, it was an unknown workman at the Exhibition who just happened to hook up the two dynamos that had been designed by a Belgian inventor, Zenobe Gramme. One dynamo ran as an electric motor on electricity generated by the other.

This accidental discovery, that a generator could be run "backwards" to serve as a motor, was immediately utilized at the Exhibition in a spectacular public demonstration: the electric motor was made to drive a pump that supplied water for a small waterfall. Thus electromagnetic induction was first used to convert mechanical energy into electrical energy by means of a generator, which could be transmitted over a considerable distance and converted back into mechanical energy by a motor. This is the basic operation of a modern electrical transmission system: a turbine driven by steam or falling water drives a generator which converts the mechanical energy to electrical energy; conducting wires transmit the electricity over long distances to motors, toasters, electric lights, etc., which convert the electrical energy to mechanical energy, heat and light.

### A Simple meters and motors

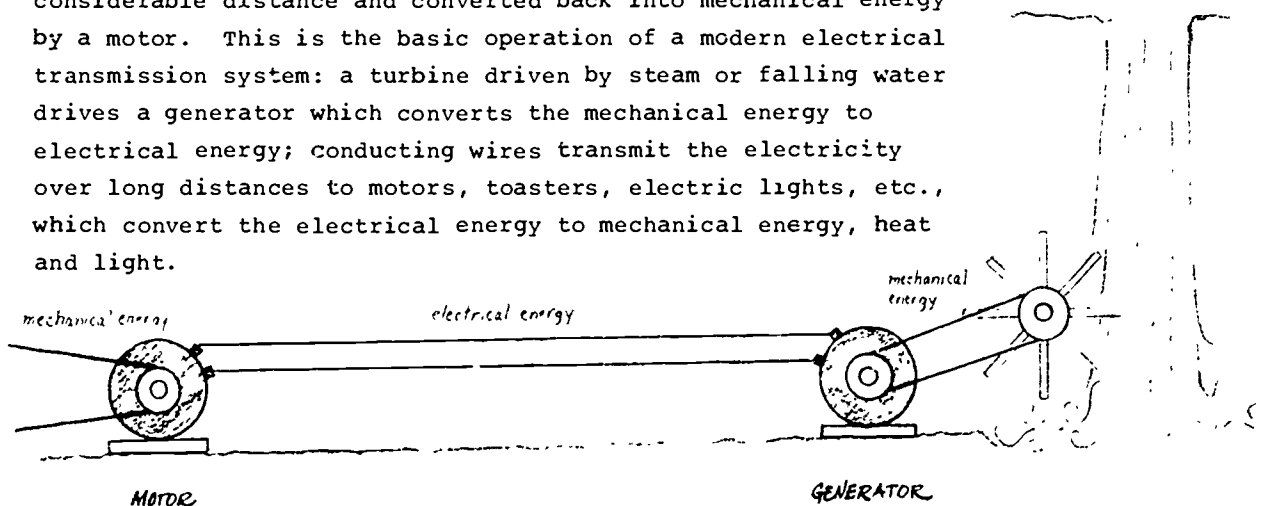

- The current for the rotating electromagnets can be induced in coils near the tops of the shaft, which are surrounded by external magnets. Thus there need be no electrical connections to the rotating parts.

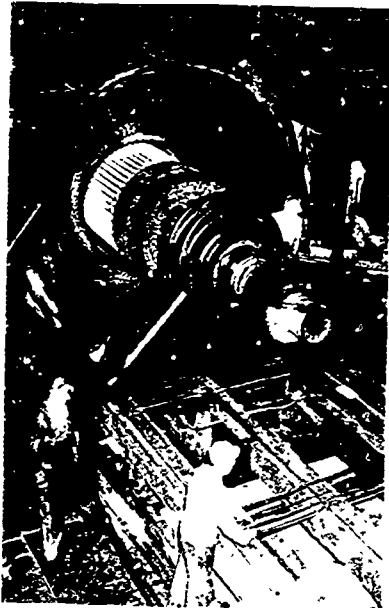

Insides of a commercial generator. As in almost all large generators, the coils of wire are around the outside and electromagnets are rotated inside.

The development of electrical generators shows the interaction of science and technology in a different light than did the development of steam engines. As was pointed out in Chapter 10, the early steam engines were developed by practical inventors who had no knowledge of what we now consider to be the correct theory of heat (thermodynamics). In fact, it was the development of the steam engine itself, and attempts by Sadi Carnot and others to improve its efficiency by theoretical analysis, that was one of the major historical factors leading to the establishment of thermodynamics. In that case, the technology came before the science. But in the case of electromagnetism, a large amount of scientific knowledge was built up by Ampère, Faraday, Kelvin and Maxwell before there was any serious attempt at practical application. The scientists who understood electricity better than anyone else were not especially interested in commercial applications, and the inventors who hoped to make huge profits from electricity knew very little of the theory. Although after Faraday announced his discovery of electromagnetic induction people started making generators to produce electricity immediately, it was not until 40 years later that inventors and engineers started to become familiar with the concepts of lines of force and field vectors. With the introduction of the telegraph, telephone, radio and alternating-current power systems, the amount of mathematical knowledge needed to work with electricity became quite large, and universities and technical schools started to give courses in electrical engineering. In this way there developed a group of specialists who were familiar with the physics of electricity and also knew how to apply it.

The growth of the electrical industry has been largely due to the public demand for electrical products. One of the first of these to be commercially successful in the United States was the electric light bulb.

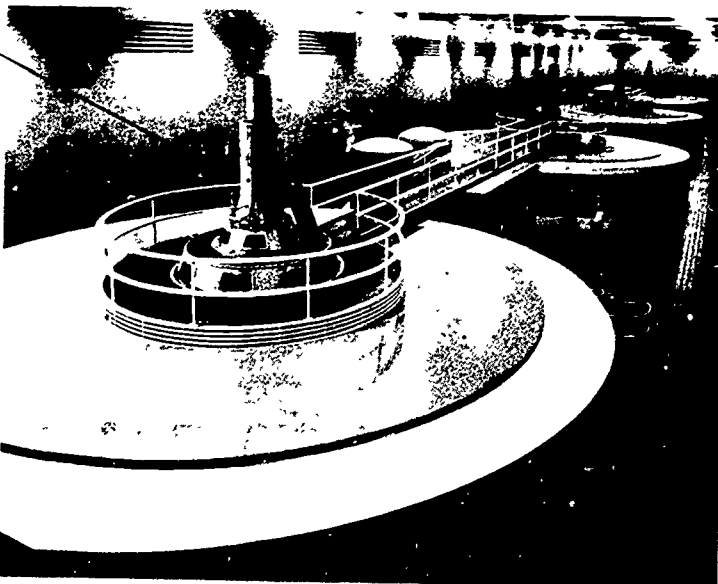

How would you make an electric motor out of a generator?

What prevented the electric motor from being an immediate economic success?

What chance event led to the beginning of the electric power age?

Water-driven electric generators producing power at the Tennessee Valley Authority. The plant can generate electric energy at a rate of over 100,000,000 watts.



### Summary 15.7

157

1 The arc light, based on Davy's experiments in 1801, was used for street lighting after the middle of the nineteenth century, but was not practical for home illumination.

2. After the invention of a sufficiently good vacuum pump, it was possible to use incandescent lighting - heating a wire to a high temperature in an evacuated bulb.

3 Thomas Edison reasoned that, in a practical lighting system, the lights must be connected in parallel rather than in series. This meant that only a small amount of the total current would go through each filament,

Davy's arc lamp



Demonstrations of the new electric light during a visit of Queen Victoria and Prince Albert to Dublin, Ireland. From Illustrated London News, August 11, 1849.

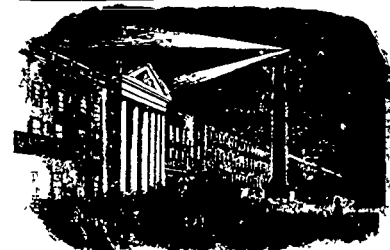

In the late 1800's, dynamo powered arc-lamps were used in some European cities.



15.7 The electric light bulb. At the beginning of the nineteenth century, illumination for buildings and homes was provided by candles and oil lamps. Street lighting in cities was practically nonexistent, in spite of sporadic attempts in London and New York to require householders to hang lights outside their houses at night. The natural gas industry was just starting to change this situation, and the first street lighting system for London was provided in 1813 when gas lights were installed on Westminster Bridge. The introduction of gas lighting in factories was not entirely beneficial in its social effects, since it enabled employers to lengthen an already long and difficult working day.

In 1801, the British chemist Humphry Davy noted that a brilliant spark appeared when he broke contact between two carbon rods which were connected to the two terminals of a battery. This discovery led to the development of the "arc light."

The arc light was not practical for general use until steam-driven electric generators had replaced expensive batteries as a source of electric current. In the 1860's and 1870's, arc lights began to be used for street lighting and lighthouses. However, the arc light was too glaring and too expensive for use in the home. The carbon rods burned up in a few hours because of the high temperatures produced by the arc, and the need for frequent service and replacement made this system inconvenient.

As Humphry Davy and other scientists showed, light can be produced simply by producing a current in a small wire (often called a "filament") to heat it to a high temperature. This is known as incandescent lighting. The major technical drawback was that the material of the filament gradually burned up. The obvious solution was to enclose the filament in a glass container from which all the air had been removed. But this was easier said than done. The vacuum pumps available in the early nineteenth century could not produce a sufficiently good vacuum for this purpose. It was not until 1865, when Hermann Sprengel in Germany invented an exceptionally good vacuum pump, that the electric light bulb in its modern form could be developed. (The use of Sprengel's pump in scientific experiments by Crookes and others was also vital to the discoveries in atomic physics which we will discuss in Chapter 18.)

Thomas A. Edison (1847-1931) was not the first to invent an incandescent light using the Sprengel pump, nor did he discover any essentially new scientific principles. What he

3.(continued) and in order to produce enough light from this small current the filament would have to have very high resistance. Eventually he succeeded in making filaments from carbonized 89 thread and similar materials. The first lighting systems were installed in 1852 and expanded rapidly.



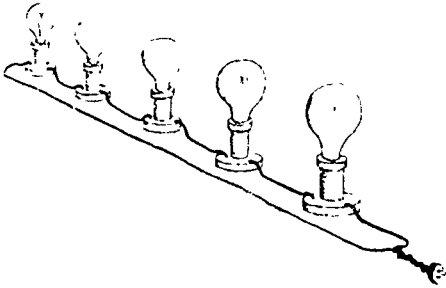
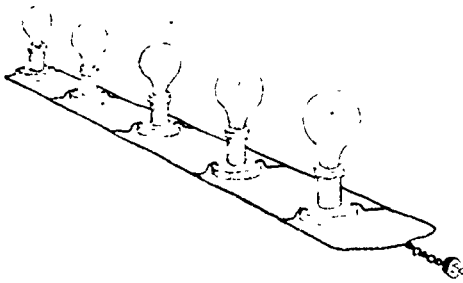

See the article "The Invention of the Electric Light" in Project Physics Reader 4.

Edison did develop a practical light bulb which could be used in homes, and (even more important) a distribution system for electricity. His system not only made the light bulb practical but also opened the way for mass consumption of electrical energy in the United States.

Edison started from the basic assumption that each customer must be able to turn on and off his own light bulbs without affecting the other lights on the line. This meant that the lights must be connected "in parallel"—like the rungs of a ladder—rather than "in series."

The choice of parallel rather than series circuits—a choice based on the way Edison thought the consumer would want to use the system—had important technical consequences. In a series circuit the same current would go through each light. In a parallel circuit only part of the total current goes through each light. To keep the total current from being too large, the current in each bulb would have to be rather small.

As we pointed out in Chapter 14, the heating effect of a current depends on both the resistance of the wire and the amount of current it carries. The rate at which heat energy is produced is proportional to  $I^2R$ ; that is, it goes up directly as the resistance, but increases as the square of the current. Therefore most inventors used high-current low-resistance bulbs, and assumed that parallel circuits would not be practical. But Edison realized that a small current will have a large heating effect if the resistance is high enough.

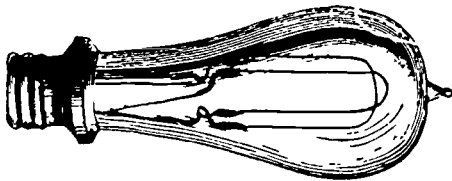

One type of Edison lamp. Note the familiar filament and screw-type base.

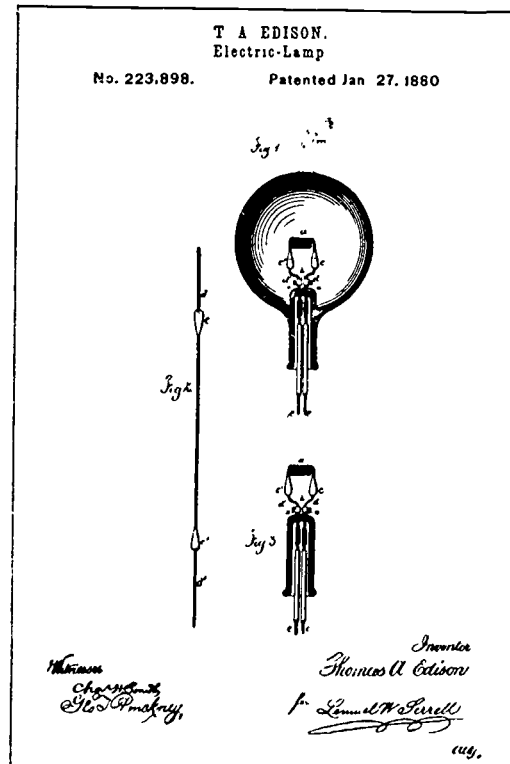



Edison was born at Milan, Ohio, and spent most of his boyhood at Port Huron, Michigan. His first love was chemistry, and to earn money for his chemical experiments, he set up his own business enterprises. He ran two stores in Port Huron, one for periodicals and the other for vegetables; hired a newsboy to sell papers on the Grand Trunk Railway running between Port Huron and Detroit; published a weekly newspaper; and ran a chemical laboratory in the baggage car of the train. His financial empire was thus growing rapidly when, in 1862 (he was now fifteen), a stick of phosphorus in his laboratory caught fire and destroyed part of the baggage car. As a result, his laboratory and newspaper equipment were evicted from the train, and he had to look around for another base of operations.



It was not long before his bad luck with the phosphorus fire was offset by a piece of good luck: he was able to save the life of the son of the station agent by pulling him out of the path of an oncoming train. In gratitude, the station agent taught Edison the art of telegraphy, and thus began Edison's career in electricity.

At left are shown two portraits of Edison. On the opposite page is a copy of the drawing that accompanied his patent on the incandescent lamp.

# EDISON'S LIGHT.

The Great Inventor's Triumph in  
Electric Illumination.

A SCRAP OF PAPER.

It Makes a Light, Without Gas or  
Flame, Cheaper Than Oil.

TRANSFORMED IN THE FURNACE.

Complete Details of the Perfected  
Carbon Lamp.

FIFTEEN MONTHS OF TOIL.

Story of His Tireless Experiments with Lamps,  
Engines and Generators

SUCCESS IN A COTTON THREAD.

The Wizard's Byplay, with Bodily Pain  
and Gold "Tailings"

HISTORY OF ELECTRIC LIGHTING.

The near approach of the first public exhibition of Edison's long looked for electric light, announced to take place on New Year's Eve at Menlo Park, on which occasion that place will be illuminated with the new light, has revived public interest in the great inventor's work, and throughout the civilized world scientists and people generally are anxiously awaiting the result. From the beginning of his experiments in electric lighting to the present time Mr. Edison has kept his laboratory guardedly closed, and no authoritative account (except that published in the *Herald* some months ago relating to his first patent) of any of the important steps of his progress has been made public—a course of procedure the inventor found absolutely necessary for his own protection. The *Herald* is now, however, enabled to present to its readers a full and accurate account of his work from its inception to its completion.

#### A LIGHTED PAPER.

Edison's electric light, incredible as it may appear, is produced from a little piece of paper—a tiny strip of paper that a breath would blow away. Through

First newspaper account of  
Edison's invention (New York  
*Herald*, December 21, 1879)

So Edison started to search for a suitable high-resistance substance for his filaments. To make such a filament, he first had to bake or "carbonize" a thin piece of a substance; then he would seal it inside an evacuated glass bulb with wires leading out. His assistants tried more than 1,600 kinds of material: "paper and cloth, thread, fishline, fiber, celluloid, boxwood, coconut-shells, spruce, hickory, hay, maple shavings, rosewood, punk, cork, flax, bamboo, and the hair out of a redheaded Scotchman's beard." His first high-resistance lamp was made with carbonized cotton thread, enclosed in a high-vacuum sealed bulb. It burned continuously for two days before it fell apart. This was in October 1879. The following year, Edison produced lamps with filaments made of Bristol board and bamboo.

The Edison Electric Light Company began to install lighting systems in 1882. After only three years of operation, the Edison company had sold 200,000 lamps. It had a virtual monopoly of the field, and began to pay handsome dividends to its stockholders.

The electric light bulb has undergone some modification since Edison's original invention. For example, the carbonized filaments of the older lamps have been replaced in newer bulbs by tungsten, which has the advantages of greater efficiency and longer life.

The widespread use of light bulbs (confirming the soundness of Edison's theory about what people would buy) led to the rapid development of systems of power generation and distribution. The need for more power for lighting led to the invention of better generators, the replacement of direct current transmission by alternating current (see below), the harnessing of waterfalls, and the invention of the steam turbine. Then, success in providing larger quantities of energy at lower cost made other uses of electricity practical. Once homes were wired for electric lights, the current could be used to run sewing machines, vacuum cleaners, washing machines, toasters, and (later on) refrigerators, freezers, radios and television sets.

We have now become so accustomed to the more sophisticated and spectacular applications of electricity that it is hard to realize the impact of something as simple as the electric light bulb. But most people who lived through the period of electrification—for example, in the 1930's and 1940's in many rural areas of the United States—agreed that the one single electrical appliance that made the greatest difference in their own lives was the electric light bulb.

- Q. Why weren't arc lights used for illuminating homes?
- Q. What device was essential to the development of the incandescent lamp?
- Q. Why did Edison require a substance with a high resistance for his light bulb filaments?

**15.8 Ac versus dc and the Niagara Falls power plant.** In Sec. 15.5 we stated that the usual form of electrical generator produces alternating current, which is changed into direct current by the use of a commutator. The reason for converting ac into dc was the general belief, held throughout most of the nineteenth century, that only dc was useful in the applications of electricity. However, as the demand for electrical power increased, some of the inherent disadvantages of dc became evident. One disadvantage was the fact that having a commutator complicated the design of the generator, especially if the ring had to be rotated at high speed. This difficulty was even more serious after the introduction of steam turbines in the 1890's, since turbines work most efficiently when run at high speeds. Another disadvantage was the fact that there was no convenient way to change the voltage of direct current.

The use of high voltages to minimize power loss. One reason for wanting to change the voltage which drives the current in a transmission system involves the amount of power lost in heating the transmission wires. When there is a current  $I$  in a transmission wire of resistance  $R$ , the amount of power expended as heat is proportional to the resistance and to the square of the current:

$$\text{power loss} = I^2R.$$

This means that for transmission lines of a given resistance  $R$ , one wants to make the current  $I$  as small as possible in order to minimize the power loss in transmission. On the other hand, the amount of power that can be transmitted depends on the voltage as well as on the amount of current:

$$\text{power} = IV.$$

In order to balance the effect of making  $I$  small (in order to cut down power loss by heating of the wire)  $V$  must be made large. In other words, economic factors require that electricity should be transmitted at high voltages.

On the other hand, for most of the applications of electricity, especially in homes, it is neither convenient nor safe to use high voltages. Also, most generators cannot produce electricity at very high voltages (which would re-

### Summary 15.8

1 Late in the nineteenth century, various disadvantages of direct current systems became evident. In particular, to minimize power loss in transmission it was necessary to use small currents and high voltages. It was difficult to produce direct current at high voltages because the commutator segments suffered sparking and mechanical strain at high rotation speeds.

2 By using a transformer (operating on the same principle as in Faraday's original experiments on electromagnetic induction) it was possible to step up the voltage of alternating current for long distance transmission, then step it down again for use at the other end. But the transformer can't work with direct current.

3 Gaulard and Gibbs in Paris, and later Westinghouse in the United States, developed practical electrical generating and distribution systems based on a.c. However, the Edison Company opposed the introduction of a.c. systems.

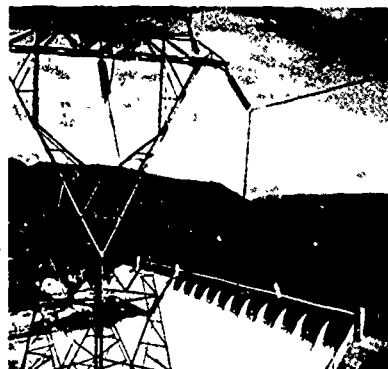

4. The ac vs dc dispute came to a head around 1890 in connection with the proposed new electrical system at Niagara Falls. The decision was finally made to use ac, and subsequently most electric systems adopted ac.

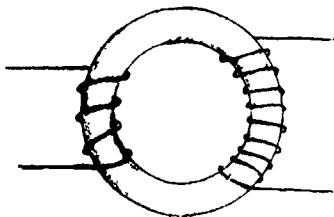

The output power can't exceed the input power, so if the output voltage is increased by a greater coil ratio, the output current will be proportionally decreased. (Well-designed transformers have efficiencies as high as 95%.)

158

quire excessively high speeds of the moving parts). Therefore we need some way of "stepping up" the electricity to a high voltage for transmission, and some way of "stepping it down" again for use at the other end. In short, we need a transformer.

A transformer can easily be made by a simple modification of Faraday's induction coil (Sec. 15.4). Faraday was able to induce a current in a coil of wire (which we call the secondary coil) by winding this coil around one side of an iron ring, and then changing a current in another coil (the primary coil) which is wound around the other side of the ring. A current is induced in the secondary coil when the primary current changes. If the primary current is changing all the time, then a current will continually be induced in the secondary. An alternating current in the primary coil (as from a generator without a commutator) will induce an alternating current in the secondary coil.

We need just one additional fact to make a useful electric transformer: if the secondary coil has fewer turns than the primary, the alternating voltage produced across the secondary coil will be lower than the voltage across the primary; if the secondary has more turns than the primary, the voltage produced across the secondary will be greater than across the primary. This fact was discovered by Joseph Henry, who built the first transformer in 1838.

Electricity could be generated on a large scale most economically with a high-speed steam turbine, but this is difficult to do if we have to use a commutator to convert ac in the coils inside the generator into dc in the outside circuit. (The commutator is likely to fall apart under the huge strains set up by high-speed rotation.) Furthermore, it is desirable to use very high voltages (and low currents) on long-distance transmission lines to minimize power loss by heating; but the only practical device for changing voltage is the transformer, which works only for ac, not for dc. Commutators could be eliminated and voltages changed easily if ac were used for large-scale generation and distribution of electric power.

The first ac system was demonstrated by Gaulard and Gibbs of Paris in 1883. An experimental line which powered arc and incandescent lighting, through transformers, was installed in a railway line in London in 1884, and another one shortly afterward in Italy. An American engineer, George Westinghouse, saw the Gaulard-Gibbs system exhibited in Italy and purchased the American patent rights for it. Westinghouse had already



gained a reputation by his invention of the railway air brake, and had set up a small electrical engineering company in Pittsburgh in 1884. After making some improvements in the transformers, the Westinghouse Electric Company set up its first commercial installation to distribute alternating current for incandescent lighting in Buffalo, New York, in 1886.

At the time of the introduction of the Westinghouse ac system in the United States, the Edison Electric Light Company held almost a complete monopoly of the incandescent lighting business. The Edison Company had invested large amounts of money in providing dc generating plants and distribution systems for most of the large cities. Naturally Edison was alarmed by a new company which claimed to produce the same kind of illumination with a much cheaper system. There was a bitter public controversy, in which Edison attempted to show that ac is unsafe because of the high voltages used for transmission. In the middle of the dispute, the New York State Legislature passed a law establishing electrocution as a means of capital punishment, and this seems to have aroused some of the popular fear of high voltage.

Nevertheless, the Westinghouse system continued to grow, and since there were no spectacular accidents, the public accepted ac as being reasonably safe. The invention of the "rotary converter" made it possible to convert ac into dc for use in local systems already set up with dc equipment, or to power individual dc motors. Consequently the Edison company (later merged into General Electric) did not have to go out of business when ac was generally adopted.

The final victory of the ac system was assured in 1893, when the decision was made to use ac for the new hydroelectric plant at Niagara Falls. In 1887, businessmen in Buffalo had pledged \$100,000 to be offered as a prize "to the inventors of the World" who would design a system for utilizing the power of the Niagara River "at or near Buffalo, so that such power may be made practically available for various purposes throughout the city." The contest attracted worldwide attention, not only because of the large prize but also because large quantities of electrical power had never before been transmitted over such a distance—it was 20 miles from Niagara Falls to Buffalo. The success or failure of this venture would influence the future development of electrical distribution systems for other large cities.

It was a close decision whether to use ac or dc for the Niagara Falls system. The demand for electricity in 1890

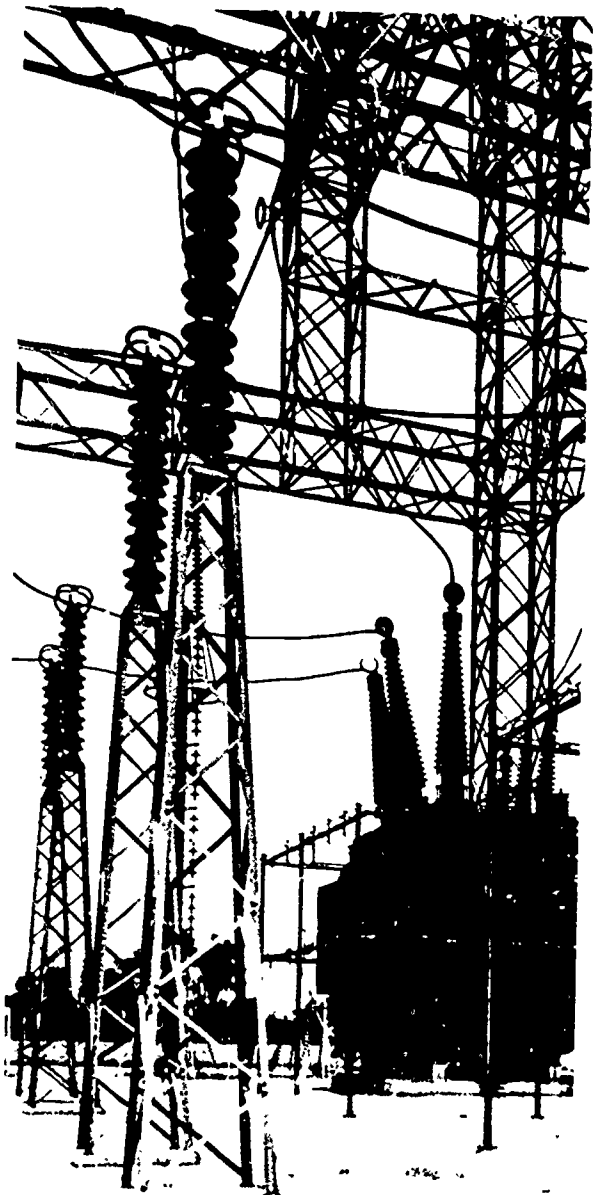

### Commercial Distribution of Electric Power

The commercial distribution of ac electric power requires elaborate transmission facilities. Generator output voltages of about  $10^4$  volts are stepped up to about  $10^5$  volts for transmission, stepped down to about  $10^4$  volts for local distribution, and further stepped down to about  $10^1$  volts by neighborhood power-pole transformers. Within the home, it may be stepped down further (often to 6 volts for doorbells and electric trains) and stepped up by transformers in radio and TV sets for operating high-voltage tubes.

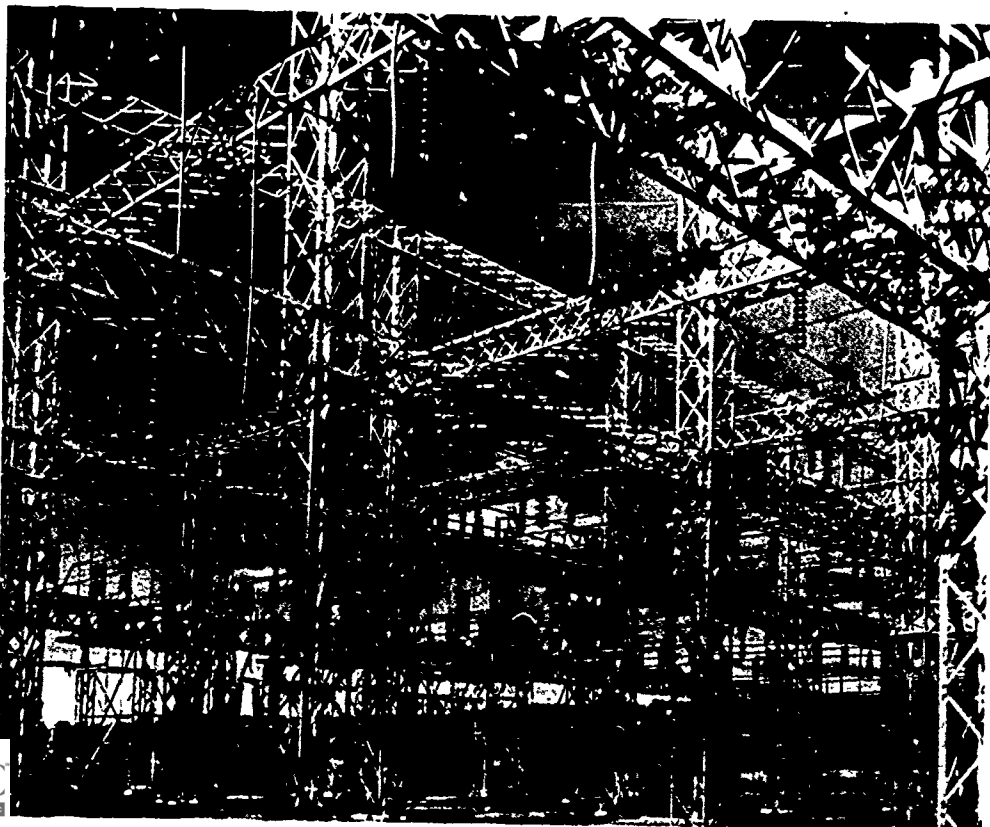
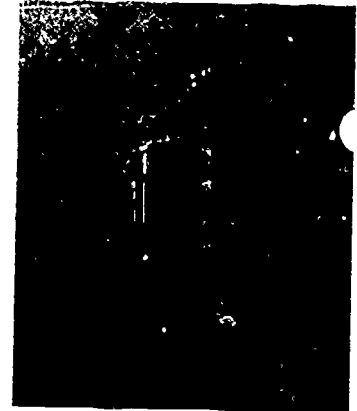
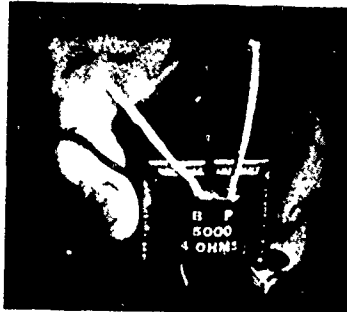



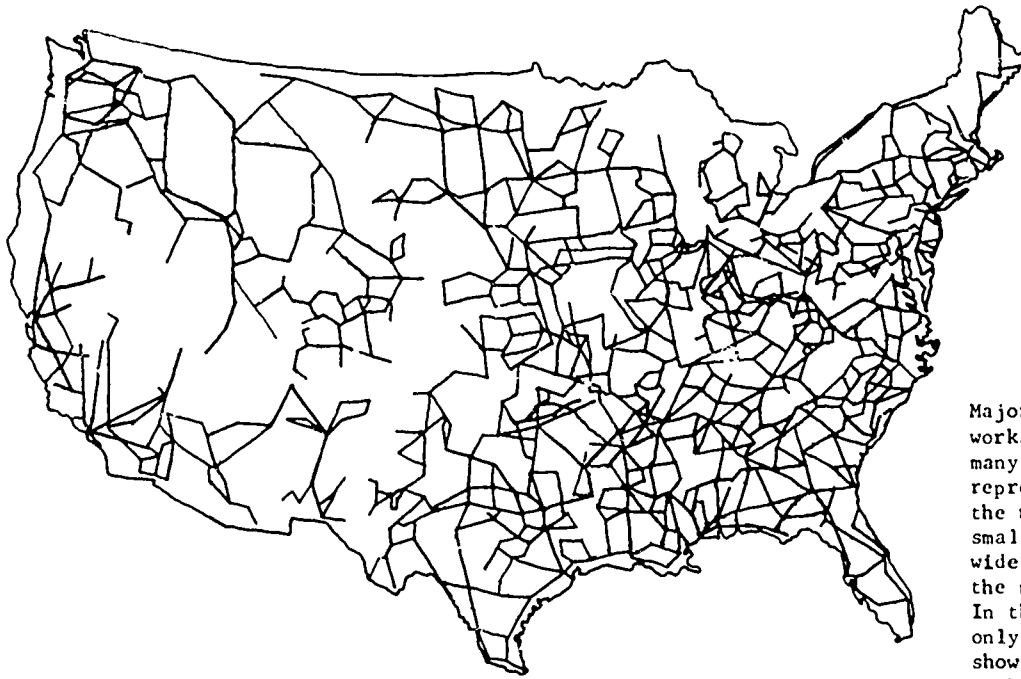

Major electric transmission networks in the United States. In many cases several lines are represented by a single line on the map. Not shown are the small-capacity lines serving widely scattered populations in the mountainous and desert areas. In the densely-populated areas only the high-voltage lines are shown. Lines drawn in gray are to be completed by 1970.



The interdependence of our modern electrical civilization was dramatically demonstrated at about 5 p.m. on November 9, 1965, when a faulty electrical relay in Canada caused a power failure and total blackout throughout most of the northeastern part of the United States.

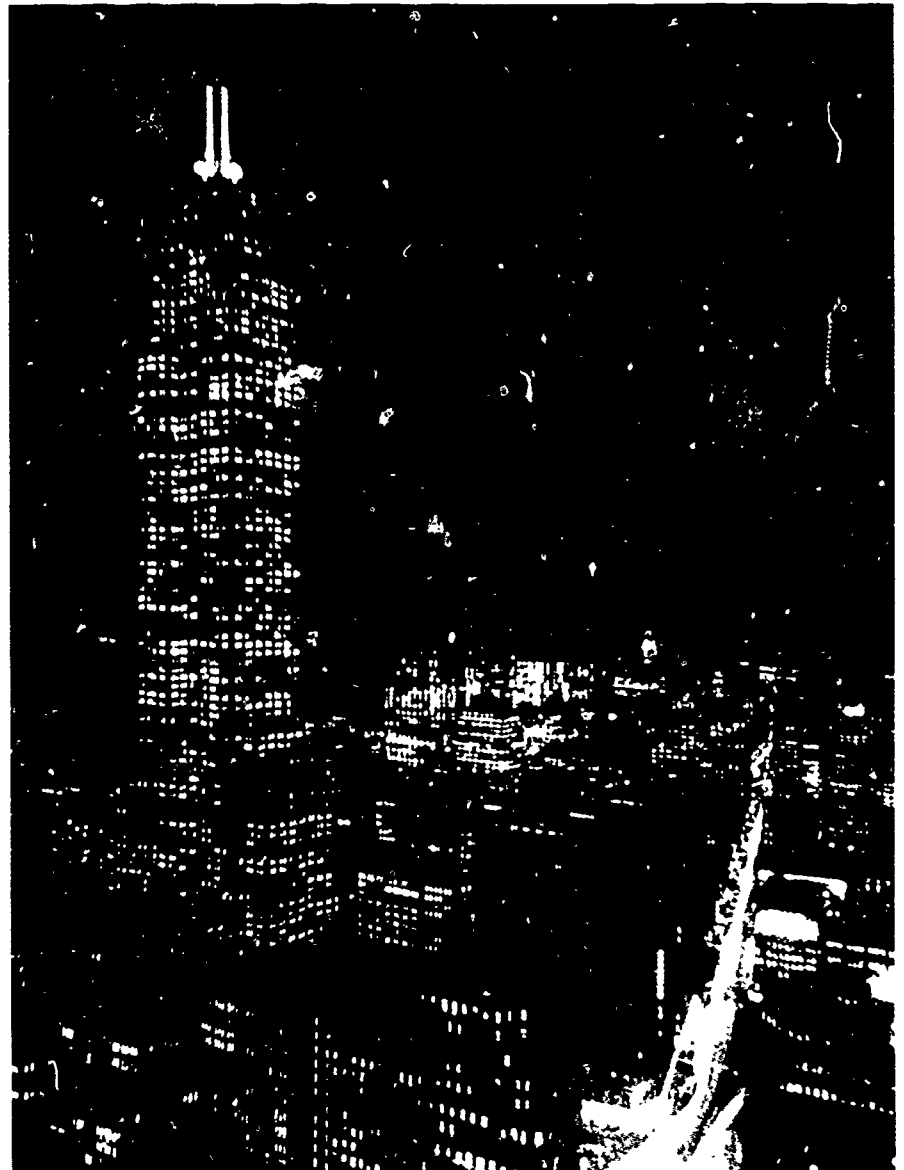
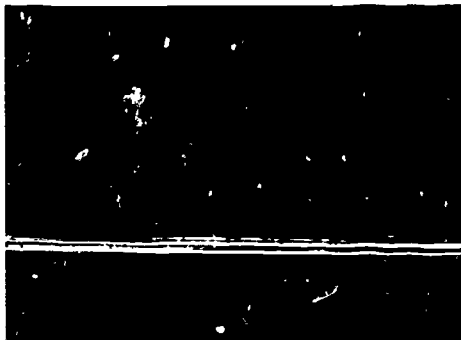

was mainly for lighting, which meant that there would be a peak demand in the evening; the system would have to operate at less than full capacity during the day and late at night. Some engineers proposed that, even though ac could be generated and transmitted more efficiently, a dc system would be cheaper to operate if there were much variation in the demand for electricity. This was because batteries could be used to back up the generators in periods of peak demand. Thomas Edison was consulted, and without hesitation he recommended dc. But the Cataract Construction Company, which had been formed to administer the project, delayed making a decision.

The issue was still in doubt in 1891 when, at the International Electrical Exhibition in Frankfort, Germany, an ac line carrying sizable quantities of power from Frankfort to Lauffen (a distance of 110 miles) was demonstrated. Tests of the line showed an efficiency of transmission of 77%. That is, for every 100 watts fed in at one end of the line, only 23 were wasted by heating effects in the line, and the other 77 were delivered as useful power. The success of this demonstration reinforced the gradual change in expert opinion in favor of ac over dc, and the Cataract Company finally decided to construct an ac system.

After the ac system had been established, it turned out that the critics had been wrong in their prediction about the variation of demand for electricity throughout the day. Electricity was to have many uses besides lighting. In the 1890's, electric motors were already being used for street railway cars, sewing machines and elevators. Because of these diverse uses, the demand for electricity was spread out more evenly during each 24-hour period. In the particular case of the Niagara Falls power plant, the source of energy—the flow of water down the Niagara River—made it possible to produce energy continuously without much extra cost. (The boiler for a steam turbine would either have to be kept supplied with fuel during the night, or shut down and started up again in the morning.) Since hydroelectric power was available at night at low cost, new uses for it became possible. The Niagara Falls plant attracted electric furnace industries, continually producing such things as aluminum, abrasives, silicon and graphite. Previously the electrochemical processes involved in these industries had been too expensive for large-scale use, but cheap power now made them practical. These new industries in turn provided the constant demand for power which was to make the Niagara project even more profitable than had originally been expected.

The first transmission of power to Buffalo took place in November 1896. By 1899, there were eight 5,000-horsepower units in operation at Niagara, and the stockholders of the Cataract Construction Company had earned a profit of better than 50% on their investment. By this time the electro-chemical industries, which had not figured in the original plans at all, were using more power than lighting and motors together.

As a postscript to the story of ac versus dc, it should be mentioned that dc is now coming back into favor for long-distance transmission of electric power at very high voltages. The reasons for this turnabout are explained in an article, "The future of direct current power transmission," reprinted in the Unit 4 Reader.

Why is it more economical to transmit electric power at high voltage and low current than at low voltage and high current?

Why won't transformers operate with steady dc?

Wilson Dam (Tennessee Valley Authority), Alabama

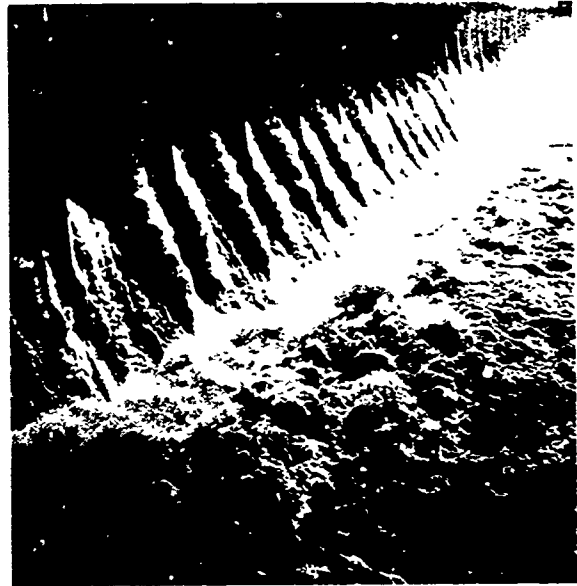

Niagara Power Plant

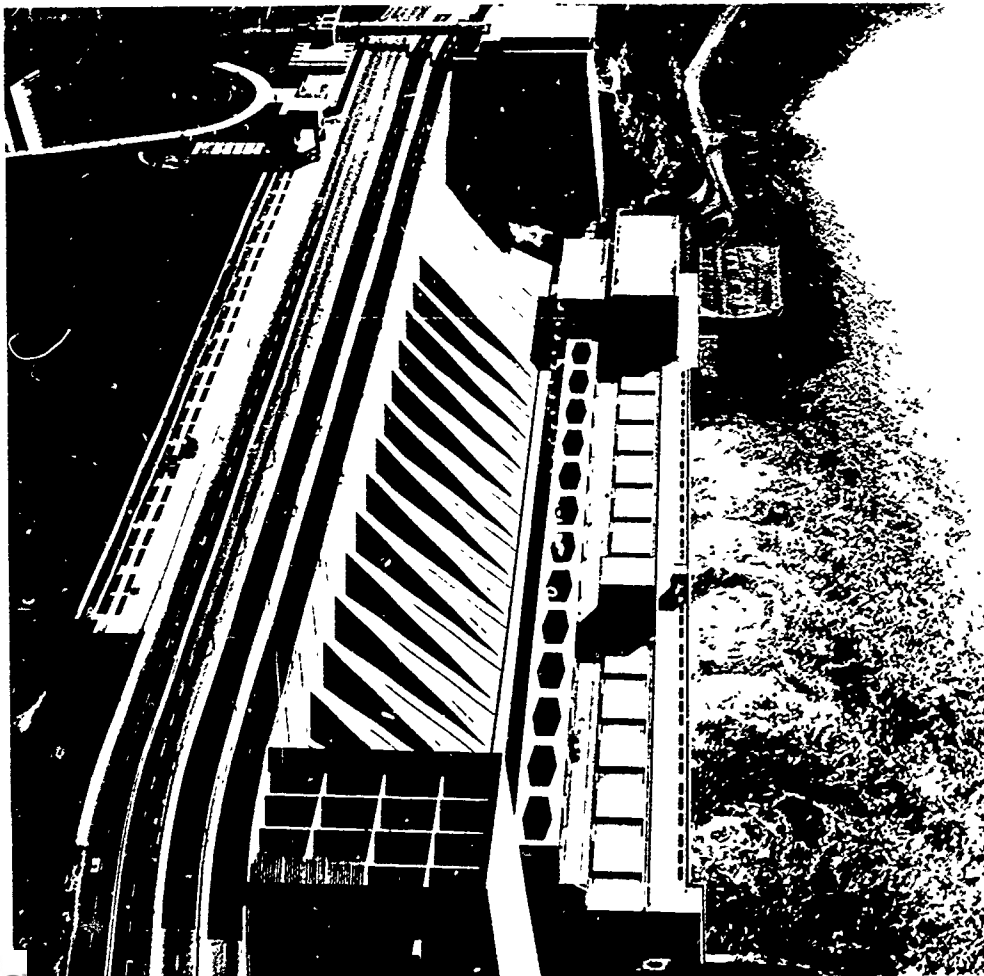

The general principle of hydroelectric power generation is shown in this sketch: water flowing from a higher to lower level turns turbine blades attached to a generator shaft. The details of construction vary widely.

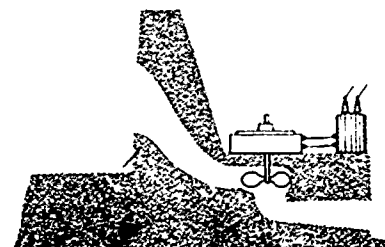

### Summary 159

1. From an optimistic viewpoint, electricity has many advantages: it saves us much physical labor, makes decentralization possible without giving up the advantages of city life, unites a large country by providing rapid transportation and communication, and facilitates cultural activities.

2. From a pessimistic viewpoint, electricity has not solved the real problems of society but only intensified them: it accelerates the depletion of natural resources, widens the gap between rich and poor, and makes us overly dependent on technology.

3. Electricity itself is neither good nor bad but simply increases the potential for applications of all kinds. Wise use of electricity will be enhanced by some understanding of it.

See the "Letter from Thomas Jefferson" in Project Physics Reader 4.

See "The Electronic Revolution" in Project Physics Reader 4.

**15.9 Electricity and society.** Many times during the last hundred years, enthusiastic promoters have predicted that a marvelous future is in store for us. We need only stand back and watch the application of electricity to all phases of life. First of all, the backbreaking physical labor that has been the lot of 99% of the human race throughout the ages will be handed over to machinery run by electricity; the average citizen will have nothing more to do except push buttons for a few hours a day, and then go home to enjoy his leisure. Moreover, the old saying that "a woman's work is never done" will be forgotten, since electric machines will do all the cleaning, laundering and ironing, preparation of food and washing of dishes.

A second social purpose of electricity was conceived by President Franklin D. Roosevelt and others who believed that country life is more natural and healthy than city life. They saw that the steam engine had provided a source of power that could take over most work done by humans and animals, but only at the price of concentrating people in cities. But now that electrical transmission of power was possible, people could go back to the country without sacrificing the comforts of city life. One of the major achievements of Roosevelt's administration in the 1930's was the rural electrification program, which provided loans for rural cooperatives to install their own electrical generating and distribution systems in areas where the private power companies had previously found it unprofitable to operate. Federal power projects such as the Tennessee Valley Authority also assisted the campaign to make electricity available to everyone. By making country life more luxurious and reducing the physical labor involved in farming, electrification should have reversed the migration of people from rural to urban areas.

A third effect of electricity might be to unite a large country into a single social unit by providing rapid transportation and even more rapid communication between the different parts. To mention a frequently cited analogy: the dinosaur became extinct because his communication system was not adequate for such a large organism. Human society evolves much as the biological organisms: all parts develop in step and increase their interdependence. It follows that telephone communications and modern civilization had to develop together. The telephone would be necessary only in a complicated society and, as is now recognized, a complicated society cannot operate without a communications system something like the telephone.

Having taken care of these problems for a large part of the population—getting work done, acquiring a more healthful environment, finding out what's going on and being able to do something about it—man now comes face to face with a new problem, or rather, a problem that was encountered before by only a tiny fraction of the world's population. Thanks to advances in science and technology, we no longer have to spend almost all of our time working for the bare necessities of life. Now, what is it that we really want to do? Whatever it might be, electricity might help us do it better. With electric lighting, we can read books at night, or attend large meetings, plays and concerts in public buildings. None of these things were impossible before electrical illumination was developed, but candles and gas lamps were messy, hard on the eyes, and (when used on a large scale) expensive and hazardous. With the telegraph, telephone, radio and television we can quickly learn the news of events throughout the world, and benefit from exchanging facts and opinions with other people.

A cynical opinion. Wonderful as all this seems, a skeptic might take a much dimmer view. He might argue, for example, that by exploiting the resources of fossil fuel (coal, oil and gas) on his planet to do his work for him, man has used up in only 200 years most of the reserves of chemical energy that have been accumulated over the last two hundred million years. Our skeptic might claim that man has created a social system in which the virtues of honest toil and pride of workmanship have begun to be endangered by a working life of monotonous triviality for much of the population and chronic unemployment for some of the rest. The rise in the standard of living and acquisition of new gadgets and luxuries by many of those living in the rich industrial countries have not brought tranquility of spirit, but often only created a demand for more and more material possessions. Meanwhile the less fortunate citizens of the world, separated more and more from the rich countries that exploited them, look on in envy and anger.

As for the labor-saving devices sold to the modern housewife, have they really made things any easier for her? The housewives in upper- and middle-income families work just as much as before, for what appliances now do used to be done by servants, perhaps better. The social changes that accompanied industrialization and electrification have also generated many new jobs for untrained women, and these jobs are more attractive than domestic service. Families with low

See the article on "High Fidelity" in Project Physics Reader 4.

*"The electric telegraph, if successful, would be an un-mixed evil to society; would be used only by stock jobbers and speculators - and the present Post Office is all the public utility requires."*

DR BURBECK, of The Mechanics Institute, England, 1837

incomes, if they can afford to buy just one major electrical appliance usually don't choose labor saving gadgets but a television set—and much of what comes out of that, our skeptic says, contributes nothing to a better life!

The decentralization of population which electricity was supposed to produce has come about but in an unexpected way. The upper and middle income inhabitants of cities have indeed been able to escape to the suburbs where they still enjoy all the convenience and pleasures of the electrical age. But they have left behind them urban ghettos crowded with minority groups whose frustration at being deprived of the benefits of the "affluent society" is only aggravated by the scenes of suburban life presented to them on television. As for the farmer, modern technology has made his fields so productive that he sometimes works himself out of a job.

Electrical communications and rapid transcontinental transportation have bound us into a close-knit interdependent social system. But this has its disadvantages too. Thus, an unforgiving electronic computer may dredge up all a man's past mistakes when he applies for a job.

The interdependence of our modern electrical civilization was dramatically demonstrated at about 5 p.m. on November 9, 1965, when a faulty electrical relay in Canada caused a power failure and total blackout throughout most of the northeastern part of the United States. The only towns in New England that had electric lights that night were the ones whose independent electrical systems had refused to tie into the interstate power grid.

Electricity: good or bad? The point of such criticism is that it illustrates the other half of the total story: electricity, like any other area of scientific discovery and technological improvement, is neither good nor bad by itself. Electricity increases enormously the possibilities open to us, but we still have to choose among them. The decisions about the large-scale applications of electricity cannot be left to the experts in physics or engineering, or to the public utility companies, or to government agencies. They must be thrashed out by citizens who have taken the trouble to learn something about the physical forces that play such an important role in modern civilization—whether in the field of electrification, or the coming large-scale use of nuclear power, or the introduction of automation and other uses of computers, or whatever lies over the horizon.





Electric power lines in New York State

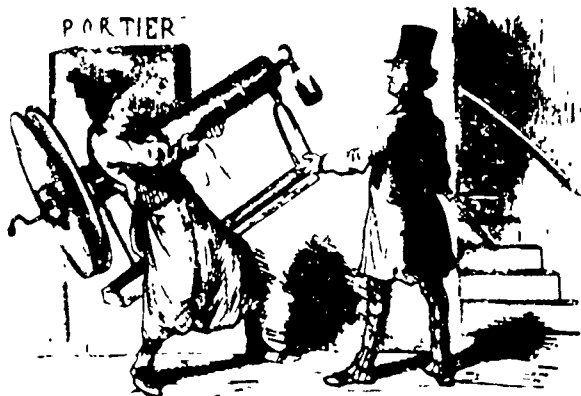

How a French cartoonist imagined the lodger of the future would be given his electric "candle" by the concierge. From *L'Illustration*, 1848.



15.1 "manpower"; animals; moving water; fuels; etc.  
 What sources of energy were there for industry before the electrical age? How was the energy transported to where it was needed?  
*Walking; wheels; pipes; etc.*

15.2 Oersted discovered that a magnetic needle was affected by a current. Would you expect the magnetic needle to exert a force on the current? Why? How would you detect this force?  
*Make wire part of sensitive balance*

15.3 In which of these cases does electromagnetic induction occur?  
*In all but (d)*  
 a) A current is started in a wire held near a loop of wire.  
 b) A current is stopped in a wire held near a loop of wire.  
 c) A magnet is moved through a loop of wire.  
 d) A loop of wire is held in a steady magnetic field.  
 e) A loop of wire is moved across a magnetic field.

15.4 How do the conditions for the induction of currents by magnetic fields differ from those for the production of magnetic fields by currents?  
*Steady currents produce magnetic fields, but only changing magnetic fields produce currents.*

15.5 Refer to the simple ac generator shown on p. 84. Suppose the loop is being rotated counter clockwise and we consider the segment b as it is pictured in the third drawing, moving down across the magnetic field. A current of positive charge out of the page.

A useful rule: if your fingers point along  $\vec{B}$ , and your thumb along  $\vec{v}$ ,  $\vec{F}$  will be in the direction your palm would push. For pos. charges use the right hand, and for neg. use the left hand.

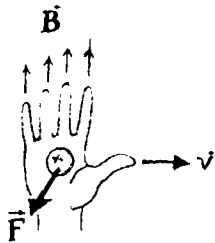

- Use the hand rule to determine the direction of the current induced in b.
- The induced current is an additional motion of charges across the magnetic field, thus an additional magnetic force acts on segment b. Use the hand rule to determine the direction of the additional force, but before doing so try to guess the direction of the force. *Up.*
- Determine the direction of the additional force on charges in the segment labeled a, which is moving upwards across the field. *Down.*

15.6 Why should a generator coil be much harder to rotate when it is connected to a load, such as a lamp, than when it is disconnected from any load?  
*Magnetic force on induced current*

15.7 Suppose two bar magnets, each held by one end at the same level but a few feet apart, are dropped so that one of them passes through a closed loop of wire. Which magnet reaches the ground first? Why?  
*Outside magnet Reaction on magnet of induced current*

15.8 Sketch a current of charges in a wire perpendicular to a magnetic field and use the hand rule to find the direction of force on the current. Imagine the wire moves sideways in response to the force. This sideways motion is an additional motion across the field and so each charge in the wire experiences an additional force. In what direction is the additional force on the charges?  
*Oposite to current*

15.9 Connect a small dc motor to a battery through a current meter. By squeezing on the motor shaft, vary the speed of the motor. On the basis of your answer to question 15.8, can you explain the effect that motor speed has on the current?  
*The motion of the coils through the field induces a back-voltage.*

15.10 A dozen Christmas tree lights are connected in series and plugged into a 120-volt wall outlet.

- If each lamp dissipated 10 watts of heat and light energy, what is the current in the circuit? *1 amp*
- What is the resistance of each lamp? *10 ohms*
- What would happen to these lamps if they were connected in parallel across the 120-volt line? Why?  
*Burn out.*

15.11 Suppose we wanted to connect a dozen 10-watt lamps in parallel across a 120-volt line. What resistance must each lamp  
*Resistance is low*

*Slower the motor, greater the current.*



have in this case? To determine the resistance, proceed by answering the following questions:

- a) What current will there be in each lamp? *0.5 amp*
- b) What is the resistance of each lamp? *1440 ohms*



Compare the total current for this string of 10-watt lamps with the total current in the string of lamps in the previous question.

15.12 A man who built his own boat wanted to equip it with running lights and an interior light, but was puzzled about whether he should install a 6-volt system or a 12-volt system. He finally decided to use the 12-volt system because he reasoned that for a given power (wattage) of light he would have less heating losses in the connecting wires if he used the higher voltage system. Let us see if his reasoning is correct. Suppose that his interior lamp is to be a 6-watt lamp. (A 6-watt lamp designed for use in 6-volt systems has a resistance of 6 ohms, but if designed for use in 12-volt systems a lamp has a resistance of 24 ohms.) The connecting wire has a resistance of 1/5 ohm.

- a) If it were to operate at its full 6-watt rating, what current would the lamp require in each of the two systems? *1 amp, 1/2 amp*
- b) If the currents calculated in (a) were the actual currents, what power loss would there be in the connecting wires in each case? Was his reasoning correct? *Yes. 1/5 watt, 1/20 watt*
- c) Because of the resistance of the connecting wires, the lamps described will not actually operate at full capacity. Recalculate parts (a) and (b) to determine what would be the actual currents, power losses, and power consumptions of the lamps. *0.97 amp, 0.19 watt, 5.6 watt; 0.50 amp, 0.05 watt, 6 watt*

15.13 A transformer for an electric train is used to "step-down" the voltage from 120 volts to 6 volts. The output power from the secondary coil is not much less than the input power to the primary coil. Suppose the current in the primary coil were 1/2 amp, what would be the current in the secondary coil if the input power and output power were the same? *5 amp*

15.14 For a transformer, the ratio of the secondary voltage to the primary voltage is the same as the ratio of the number of turns of wire on the secondary coil to the number of turns of wire on the primary coil. If a transformer were 100 per cent efficient, the output power would equal the input power; assume such is the case and derive an expression for the ratio of the secondary current to the primary current in terms of the turn ratio.  $\frac{I_s}{I_p} = \frac{N_p}{N_s}$

15.15 On many transformers thicker wire is used for one of the coils than for the other. Which would you expect has the thicker wire, the low-voltage coil or the high-voltage coil? *Low, because of greater current.*

15.16 Comment on the advisability of getting out of a car over which a high-voltage power line has fallen. *Never touch car and ground at same time.*

15.17 What factors made Edison's recommendation for dc for the Niagara Falls system in error? *Unexpected daytime use, etc.*

15.18 Write a report comparing the earliest electric automobiles with those being developed now. *Activity*

15.19 What were some of the major effects of electricity on society? *Discussion*

15.20 It was stated on p. 85 that the output of a dc generator can be made smoother by using multiple windings. If each of two loops were connected to commutators as shown in the margin, what would the output current of the generator be 1. *?*



Multiple commutator segments of an automobile generator.

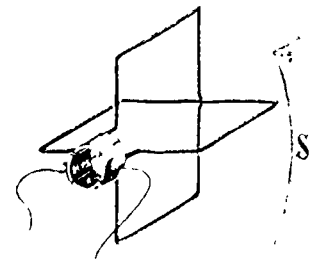

Chapter 16    Electromagnetic Radiation

Section		Page
16.1	Introduction	107
16.2	Maxwell's formulation of the principles of electromagnetism	108
16.8	The propagation of electromagnetic waves	112
16.4	Hertz's experiments	116
16.5	The electromagnetic spectrum	120
16.6	Maxwell: intellectual characteristics and attitudes	126
16.7	What about the ether?	129

Radio telescope in Alaska framed by the Northern Lights



16.1 Introduction. On April 11, 1846, a distinguished physicist, Sir Charles Wheatstone, was scheduled to give a lecture at the Royal Institution in London. Michael Faraday, who frequently gave the Friday evening lectures at the Royal Institution, was prepared to introduce Wheatstone to the expectant audience of fashionable ladies and gentlemen. But at the last minute, just as Faraday and Wheatstone were about to enter the lecture hall, Wheatstone got stage fright, turned around and ran out into the street. Because Faraday felt obliged to give the lecture himself we now have on record some of Faraday's speculations which, as he later admitted, he would never have made public had he not suddenly been forced to speak for an hour.

Faraday, ordinarily so careful to confine his remarks to his experiments and observations, used this occasion to disclose his speculations on the nature of light. They can best be understood if we recognize that Faraday, like Oersted before him, believed that all the forces of nature are somehow connected. Electricity and magnetism, for example, could not be separate things that just happen to exist in the same universe; they must really be different forms of the same basic force. This metaphysical conviction, coming out of the speculations of Schelling and other German nature philosophers at the beginning of the nineteenth century, had inspired Oersted to search in the laboratory for a connection between electricity and magnetism. Eventually he found it in his discovery that an electric current in a conductor turns a nearby magnet. Faraday too, had been guided by a belief in the unity of natural forces.

Could light also be considered another form of this basic "force?" Or rather, to ask the question using more modern terminology, is light a form of energy? If so, scientists should be able to demonstrate experimentally its connection with other forms of energy such as electricity and magnetism. Faraday did succeed in doing just this in 1845, when he showed that light traveling through heavy glass had its plane of polarization rotated by a magnetic field applied to the glass.

Having convinced himself by this experiment that there is a definite connection between light and magnetism, Faraday could not resist going one step further in his impromptu lecture the following year. He suggested that perhaps light itself is a vibration of magnetic lines of force. If two charged or magnetized objects are connected by an electric or magnetic line of force, then if one of them moves, a disturbance would be transmitted along the line of force. As

161  
Summary 16 1  
Faraday's belief that all forces of nature are connected led him to speculate that light is a vibration of electric and magnetic lines of force. Maxwell defined and developed this idea mathematically, creating the electromagnetic theory of light

Charles Wheatstone (1802-1875) made notable contributions to the sciences of acoustics, light and vision, and electricity; he invented the telegraph and the concertina.

SG 16 1

A: Science stamps

Faraday pointed out, if we assume that light waves are vibrations of lines of force, then we do not need to imagine that space is filled with an elastic substance, the ether, in order to explain the propagation of light. The lines of force could replace the ether, if we could show that lines of force have the elastic properties needed for wave transmission.

Faraday could not make this idea more precise because he lacked the mathematical skill needed to prove that waves could be propagated along lines of electric or magnetic force. Other physicists in Britain and Europe who might have been able to develop a mathematical theory of electromagnetic waves did not understand Faraday's concept of lines of force, or at least did not consider them a good basis for a mathematical theory. It was not until ten years later that James Clerk Maxwell, a Scottish mathematical physicist who had just completed his B. A. degree at Cambridge University, saw the value of the idea of lines of force and started using mathematics to express Faraday's concepts.

### 16.2 Maxwell's formulation of the principles of electromagnetism.

The work of Oersted, Ampère, Henry and Faraday established two basic principles of electromagnetism:

1. An electric current in a conductor produces magnetic lines of force that circle the conductor;
2. When a conductor moves across magnetic lines of force, a current is induced in the conductor.

James Clerk Maxwell, in the 1860's, developed a mathematical theory of electromagnetism in which he generalized these principles so that they applied to electric and magnetic fields in conductors, in insulators, even in space free of matter.

Maxwell proceeded by putting Faraday's theory of electricity and magnetism into mathematical form. In 1855, less than two years after completing his undergraduate studies, Maxwell presented to the Cambridge Philosophical Society a long paper entitled, "On Faraday's Lines of Force." Maxwell described how these lines are constructed:

...if we commence at any point and draw a line so that, as we go along it, its direction at any point shall always coincide with that of the resultant force at that point, this curve will indicate the direction of that force for every point through which it passes, and might be called on that account a line of force. We might in the same way draw other lines of force, till we had filled all space with curves indicating by their direction that of the force at any assigned point.

The lines representing magnetic lines of force give the direction of the force on a magnetic north pole.



The force on the south pole at the other end would be opposite to  $\vec{B}$ .

The lines representing electric lines of force give the direction of the force on a positive charge.



Maxwell stated that his paper was designed "to show how, by a strict application of the ideas and methods of Faraday, the connection of the very different orders of phenomena which he has discovered may be clearly placed before the mathematical mind." In later papers during the next ten years Maxwell created his own models of electric and magnetic induction, expressed these models in mathematical form, and went on to add an entirely new idea of far-reaching consequences: an electric field that is changing with time generates a magnetic field. Not only currents in conductors, but changing electric fields in insulators such as glass or air or the ether are accompanied by magnetic fields.

It is one thing to accept this newly stated connection between electric and magnetic fields; it is another task, both harder and more fun, to understand the physical necessity for such a connection. The next paragraphs are intended to make it seem reasonable and to give some notion how Maxwell came to propose that a changing electric field is accompanied by a magnetic field.

An insulator (glass, wood, paper, rubber) contains equal amounts of negative and positive charge (Sec. 14.3). In the normal state these charges are distributed so that the net charge in every large region of the material is zero. When these charges are subjected to electrical forces by placing the insulator in an electric field, the positive charges are pushed in one direction, the negative in the opposite direction. None of the charges in an insulating material (in contrast to a conductor) is free to move through the matter; the charges can only be displaced a small distance before the restoring forces in the insulator balance the force due to the electric field. The small displacement of charges that accompanies a changing electric field in an insulator constitutes a current. This current Maxwell called the displacement current. Maxwell assumed that this displacement current is just as effective in producing a magnetic field as a conduction current of the same magnitude. In an insulator the current of charges undergoing a displacement is directly proportional to the rate at which the electric field is changing in time. Thus the magnetic field that circles the displacement current can be considered a consequence of the time-varying electric field. If it is assumed that this model developed for matter can be applied to space free of matter (an apparently absurd idea that works) it follows that, under all circumstances an electric field that is changing with time generates a magnetic field.

*Summary 16 2*  
 Maxwell extended electromagnetic theory to include two principles that apply under all circumstances: (1) a changing magnetic field produces an electric field, (2) a changing electric field produces a magnetic field.

See Maxwell's discussion "On the Induction of Electric Currents" in Project Physics Reader 4.

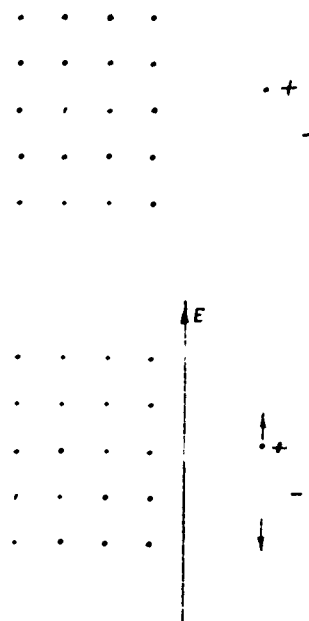

When an electric field is established in an insulating material, the + and - charges, which are bound to one another, are displaced. The displacement constitutes a current. (+ charges are represented by dots, and - charges by shaded circles.)



\* The +'s and -'s indicate direction of the  $\vec{B}$  field. The rotations shown are produced by a current of charges from A to B<sup>18,2</sup> (True to the original, some of the rotation arrows are backwards).

In developing his electromagnetic theory Maxwell devised a mechanical model that provided the connections among the electrical and magnetic quantities observed experimentally by Faraday and others.

Maxwell expressed the operation of the model in a group of equations. He found that his model and the equations representing the model suggested effects that had not yet been observed, such as the magnetic

field of a displacement current. Once he found the sought-for relations between the electric and magnetic fields, he was free to discard the mechanical model.

The intricate models devised by Maxwell and other British physicists were considered inappropriate, or worse, by many French scientists. Pierre Duhem, for example, remarked after reading about these models, "We thought we were entering the tranquil and neatly ordered abode of reason, but we find ourselves in a factory."

Maxwell later described the route he had followed from experiments, to a mechanical model, to a mathematical theory. In his paper of 1864 that summarized his work on electromagnetism, he wrote:

I have on a former occasion attempted to describe a particular kind of motion and a particular kind of strain, so arranged as to account for the phenomena. In the present paper I avoid any hypothesis of this kind; and in using such words as electric momentum and elasticity in reference to the known phenomena of the induction of currents and the [displacement of charge in insulators], I wish merely to direct the mind of the reader to mechanical phenomena which will assist him in understanding the electrical ones. All such phrases in the present paper are to be considered illustrative not as explanatory.

According to Maxwell's theory, the basic principles of electromagnetism must be expanded to include the following:

1. A changing electric field produces a magnetic

When the electric field  $\vec{E}$  between a pair of charged plates starts to increase in intensity, a magnetic field  $\vec{B}$  is induced. The faster  $\vec{E}$  changes, the more intense  $\vec{B}$  is. When  $\vec{E}$  diminishes, a  $\vec{B}$  field is again induced, in the opposite direction.

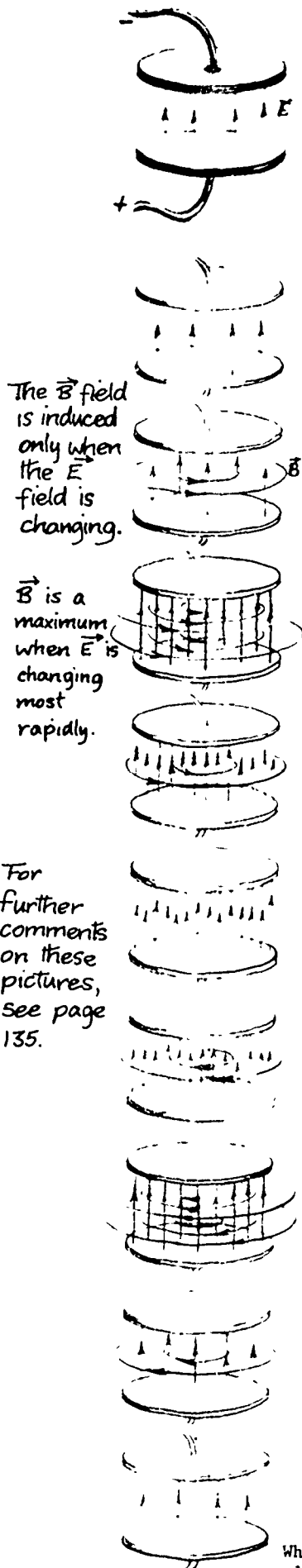

The  $\vec{B}$  field is induced only when the  $\vec{E}$  field is changing.

$\vec{B}$  is a maximum when  $\vec{E}$  is changing most rapidly.

For further comments on these pictures, see page 135.

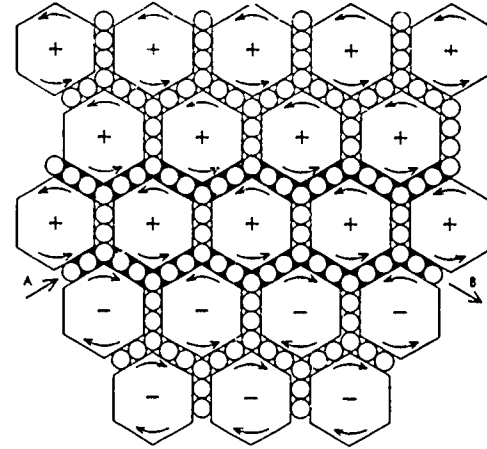

Maxwell's drawing of his mechanical model of the ether. The magnetic field is represented by rotation "H" (hexagons in the diagram and electric charges are represented by ball bearings between the cells).\*



field. The induced magnetic field vector  $\vec{B}$  is at right angles to the electric field vector  $\vec{E}$ . The magnitude of  $\vec{B}$  depends on position and on the rate at which  $\vec{E}$  is changing. (See the diagrams on the opposite page.)

2. A changing magnetic field produces an electric field. The induced electric field vector  $\vec{E}$  is at right angles to the magnetic field vector  $\vec{B}$ . The magnitude of  $\vec{E}$  depends on position and on the rate at which  $\vec{B}$  is changing. (See the diagrams on this page.)

As an illustration of the first principle, consider a pair of conducting plates connected to a source of current. As charges are moved onto the plates through the conductors connecting them to the source, the electric field in the space between the plates changes with time. This changing electric field produces a magnetic field that varies with distance from the region between the plates.

The first principle was a new prediction of Maxwell's. Previously it was thought that the only current that produced a magnetic field was the current in a conductor. The additional magnetic field that Maxwell said would arise from a changing electric field is so small in comparison to the magnetic field produced by the current in the conductors that it was not possible to measure it directly. But, as we shall see, Maxwell predicted consequences that could be tested.

As an illustration of the second principle, which was known before Maxwell's work, consider the changing magnetic field produced by, say, increasing the current in an electromagnet. This changing magnetic field induces an electric field in the region around the magnet. If a conductor is aligned in the direction of the induced electric field, the free charges in the conductor will move under its influence, producing a current in the direction of the induced field. This electromagnetic induction was discovered experimentally and explained by Faraday.

To see how Maxwell's ideas were tested we must consider his prediction of waves of a new type—electromagnetic waves.

- 
- Q1 What did Maxwell propose is generated by a changing electric field?
- Q2 What is a displacement current?
- Q3 What did Maxwell's model help him find?
- 

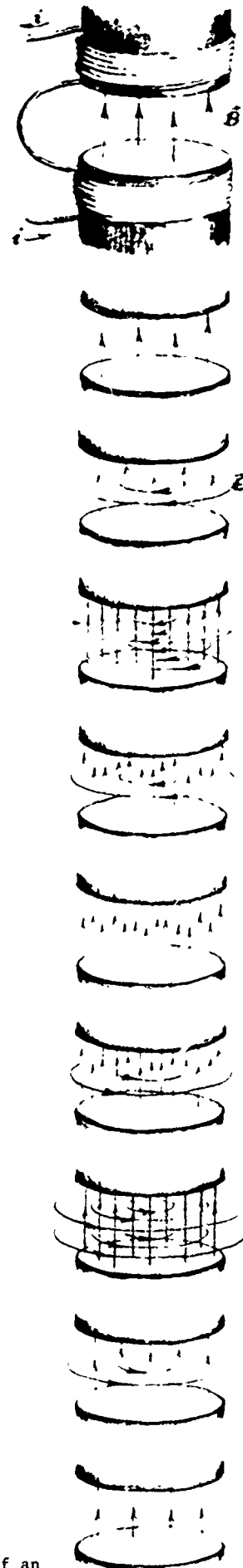

The  $\vec{E}$  field is induced only when the  $\vec{B}$  field is changing

$\vec{E}$  is a maximum when  $\vec{B}$  is changing most rapidly.

When the magnetic field  $\vec{B}$  between the poles of an electromagnet starts to increase, an electric field  $\vec{E}$  is induced. The faster  $\vec{B}$  changes, the more intense  $\vec{E}$  is. When  $\vec{B}$  diminishes, an  $\vec{E}$  field is again induced, in the opposite direction.

See "The Relationship of Electricity and Magnetism" in Project Physics Reader 4.

Actually, the electric and magnetic field changes occur together, much like the "action" and "reaction" of Newton's third law.



**Summary 16.3**  
*The reciprocal induction of electric and magnetic fields results in electromagnetic waves that travel with a speed which Maxwell calculated to be equal, within the experimental uncertainty, to the speed of light.*

As was stated in Unit 3, page 118, the speed of propagation depends on both the stiffness and density of the medium:

$$v = \sqrt{\frac{E}{d}}$$

where  $v$  is the wave speed,  $E$  is the elasticity (measure of stiffness), and  $d$  is the density.

D52 : Microwaves

**16.3 The propagation of electromagnetic waves.** Suppose we create, in a certain region of space, electric and magnetic fields that change with time. According to Maxwell's theory, when we create an electric field  $\vec{E}$  that is different at different times, this field will induce a magnetic field  $\vec{B}$  that varies with time and with distance from the region where we created the changing electric field. In addition, the magnetic field that is changing with time induces an electric field that changes with time and with distance from the region where we created the magnetic field.

This reciprocal induction of time- and space-changing electric and magnetic fields makes possible the following unending sequence of events. A time-varying electric field in one region produces a time- and space-varying magnetic field at points near this region. This magnetic field produces a time- and space-varying electric field in the surrounding space. This electric field, in turn, produces time- and space-varying magnetic fields in its neighborhood, and so on. An electromagnetic disturbance initiated at one location by vibrating charges as in a light source or the transmitter of a radio or television station, can travel to distant points through the mutual generation of the electric and magnetic fields. The electric and magnetic fields "join hands," so to speak, and "march off" through space in the form of an electromagnetic wave.

In Chapter 12 it was shown that waves occur when a disturbance created in one region produces at a later time a disturbance in adjacent regions. Snapping one end of a rope produces, through the action of one part of the rope on the other, a displacement at later times at points further along the rope. Dropping a pebble into a pond produces a disturbance that moves away from the source as a result of the action of one part of the water on the neighboring parts. Time-varying electric and magnetic fields produce a disturbance that moves away from the source as the varying fields in one region create varying fields in neighboring regions.

What determines the speed with which the electromagnetic waves travel? In the case of waves in a rope, or in water, the speed of propagation is determined by the stiffness, or force which a displaced part of the material exerts on adjacent parts, and by the density of the material. Speed increases with increasing stiffness, but decreases with increasing density. Indeed the same relation between wave speed, stiffness, and density holds for both of these mechanical wave motions, and for many other types of waves. Maxwell,

	1700	1750	1800	1831	MAXWELL	1879	1900				
Events	Peace of Utrecht	French and Indian War	French Revolution	Louisiana Purchase	War of 1812	Battle of Waterloo	Monroe Doctrine	1831	MAXWELL	1879	Spanish-American War
Rulers	Peter the Great	George Washington	Napoleon I (Napoleon Bonaparte)	Queen Victoria	Abraham Lincoln						
Science	Benjamin Franklin	Charles Augustin de Coulomb	Alessandro Volta	Joseph Henry	Charles Robert Darwin	Albert Abraham Michelson					
	Sir Isaac Newton	Joseph Priestley	Johann Karl Friedrich Gauss	Michael Faraday	Lord Kelvin (William Thomson)						
	Daniel Bernoulli	Luigi Galvani	Andre Marie Ampere	André Marie Ampère	Louis Pasteur	Simon Stevin					
	Charles Francois DuFay		Hans Christian Oersted	Thomas Young	Heinrich Hertz						
			Georg Simon Ohm								
Art	Thomas Gainsborough	William Hogarth	Francisco Goya	Joseph Mallord William Turner	Edgar Degas	Claude Monet	Vincent Van Gogh				
Literature	Samuel Johnson	Johann Wolfgang von Goethe	Percy Bysshe Shelley	Leo Nikolaevich Tolstoy	Emile Zola						
	Henry Fielding	Robert Burns	Alfred Tennyson		Mark Twain (Samuel L. Clemens)						
	Alexander Pope	Samuel Taylor Coleridge	William Blake		George Bernard Shaw						
Music	Johann Sebastian Bach	Wolfgang Amadeus Mozart	Franz Peter Schubert	Johannes Brahms	Peter Ilyich Tchaikovsky						
	George Frederick Handel	Ludwig von Beethoven	Wilhelm Richard Wagner								
	Antonio Vivaldi										
	Jean Jacques Rousseau		Karl Marx		John Dewey						
	Immanuel Kant				Friedrich Wilhelm Nietzsche						
	Francois Marie Arouet de Voltaire										

assuming that this relation would hold for electromagnetic waves, proceeded to compute the stiffness and density of electric and magnetic fields propagating through the ether. The hard problem was to find values for these two properties of the electric and magnetic fields.

L 41. Standing electromagnetic waves

F 34. Electromagnetic waves.

Maxwell made his calculations in the following way. First, he showed that the part of the model that gives stiffness to the mechanism is the part that is analogous to the electric field. The part that determines the density is the part that is analogous to the magnetic field. Next, he proved mathematically that the ratio of these two factors, which determines the wave speed, is independent of the strength of the fields. Finally, Maxwell demonstrated a remarkable property of these electric and magnetic fields: the ratio of stiffness to density, and hence the speed of the waves, is neither zero nor infinite, the extreme values one might expect in space empty of matter, but a definite quantity that can be measured in the laboratory. Quite a trip from rotating rods and ball bearings to waves that travel through space free of matter!

Maxwell showed how the speed of electromagnetic waves could be calculated from laboratory experiments in which the same quantity of electric charge is measured by two different methods. One of the methods makes use of the Coulomb force that is proportional to the magnitude of the charge ( $F \propto q$ ). The other method makes use of the magnetic force exerted on a charge moving in a magnetic field—the force that is proportional to the product of the magnitude of the charge and its speed ( $F \propto qv$ ). The two calculated values for the charge are in different units, and their ratio has the units of speed.

The actual experiment involved discharging a Leyden jar through a sensitive moving-coil meter. One calculation of the amount of charge is made from the electric force exerted on a sphere charged from the Leyden jar. The second calculation is made from the deflection of the moving coil in the field of the meter's permanent magnet as the Leyden jar is discharged through it.

The necessary measurements had been performed in Germany five years earlier by Weber and Kohlrausch. Using their values Maxwell calculated that the speed of electromagnetic waves should be 310,740,000 meters per second. He was immediately struck by the fact that this large number was very close to another speed well known in physics. In 1849 Fizeau had measured the speed of light and obtained a value of 314,858,000 meters per second. The close similarity between these two numbers was, Maxwell felt, more than coincidence. It could have been a chance occurrence, but Maxwell, with faith in the rationality of nature, believed that there must be a deep underlying reason for these two numbers being the same, within the limits of experimental error. The critical significance for physics was obvious at once to him, and he wrote:

The velocity of the transverse undulations in our hypothetical medium, calculated from the electromagnetic experiments of MM. Kohlrausch and Weber, agrees so exactly with the velocity of light calculated from the optical experiments of M. Fizeau, that we can scarcely avoid the inference that light consists in the transverse undulations of the same medium which is the cause of electric and magnetic phenomena.

By means of his generalized principles of electromagnetism, including the new idea that changing electric fields produce magnetic fields, Maxwell showed that electric and magnetic fields can propagate together as waves in space. The speed of propagation is the same as the speed of light.

Maxwell had not anticipated this agreement. In late 1861, he wrote in a letter to his friend Lord Kelvin:

I made out the equations before I had any suspicion of the nearness between the two values of the velocity of propagation of magnetic effects and that of light, so that I think I have reason to believe that the magnetic and luminiferous media are identical.

Realizing the great significance of his discovery, Maxwell turned his efforts to making the theory mathematically elegant and freeing it from his admittedly artificial model. In 1865, after he had shown that the equations of his theory could be derived from his general principles of electromagnetism without relying on special mechanical assumptions, Maxwell wrote to his cousin, Charles Cay:

I have also a paper afloat, with an electromagnetic theory of light, which, till I am convinced to the contrary, I hold to be great guns.

The synthesis of electromagnetism and optics was a great event in physics. In fact, physics had known no greater time since the 1680's when Newton was doing his monumental work on mechanics. Although Maxwell's electromagnetic theory grew up in Maxwell's mind in a Newtonian framework, it leapt out of that framework and became the second great general physical theory, a theory independent of its mechanical origins. Like Newtonian mechanics Maxwell's electromagnetic field theory was spectacularly successful. We will see something of that success in the next few sections. The success went in two different directions: the practical and the conceptual. Practically it led to a whole host of modern developments, such as radio and television. On the conceptual level it led to a whole new way of viewing the universe. The universe was not a Newtonian machine of whirling parts; it included fields and energies that no machine could duplicate. As we will note later, Maxwell's work led almost directly to the special theory of relativity, and other physical theories were nour-

Maxwell had shown that  $\vec{E}$  and  $\vec{B}$  are perpendicular to each other and to the direction of propagation of the wave. In the terminology of Chapter 12, electromagnetic waves are transverse; and as we noted in Chapter 13, it was known that light waves are also transverse.

The magnetic and luminiferous media were those ethers supposed to be responsible for transmitting, respectively, magnetic forces and light.

For a general survey of the development of physical ideas leading up to Maxwell's theory, see the article by Einstein and Infeld, "The Electromagnetic Field," in Project Physics Reader 4.

ished by it. Maxwell's field theory not only synthesized electromagnetism and light, but provided a new way of looking at the world that made possible the flowering of physics in the twentieth century.

What ratio did Maxwell use in calculating the speed of electromagnetic waves?

What discovery did he make upon calculating this speed?

*Summary 16.4  
Heinrich Hertz, using an induction coil and spark gap, succeeded in generating and detecting electromagnetic waves. He measured the speed of these waves, studied their interference and the way they are reflected, refracted and polarized. In this way he demonstrated that they have many properties characteristic of light waves. Hertz's experiments were decisive in bringing scientists to accept Maxwell's electromagnetic field theory.*

*E38: Waves, modulation, communication.*

**16.4 Hertz's experiments.** Did Maxwell's theoretical result establish that light actually does consist of electromagnetic waves, or even that electromagnetic waves exist at all? No. Most other physicists remained skeptical for several years. The fact that the ratio of two quantities determined by electrical experiments came out equal to the speed of light certainly suggested that there is some connection between electricity and light; no one seriously argued that it was only a coincidence. But stronger evidence was needed before the rest of Maxwell's theory, with its mysterious displacement current, could be accepted.

What further evidence would be sufficient to persuade physicists that Maxwell's theory was correct? Maxwell showed that his theory could explain all the known facts about electricity, magnetism and light. But so could other theories. To a modern physicist who has learned Maxwell's theory from recent textbooks, the other theories that were proposed in the nineteenth century would all seem much more complicated and artificial. But at the time, Maxwell's theory used the strange idea of fields and was difficult to understand. On the basis of simplicity Maxwell's theory could not win out in the minds of those physicists who were not accustomed to thinking in terms of fields. It could only be accepted in preference to other theories if it could be used to predict some new property of electromagnetism or light.

Maxwell himself made two such predictions from his theory. Unfortunately, he did not live to see them verified experimentally, for he died in 1879 at the age of 48.

Maxwell's most important prediction was that electromagnetic waves of many different frequencies could exist. All such waves would be propagated through space at the speed of light. Light itself would correspond to waves of only a small range of frequencies, from  $4 \times 10^{14}$  cycles/sec to  $7 \times 10^{14}$  cycles/sec—frequencies that happen to be detectable by the human eye.



To test this prediction, it was necessary to invent some apparatus that could produce and detect electromagnetic waves of other frequencies than those of light. This was first done by the German physicist Heinrich Hertz. In 1886, Hertz noticed a peculiar effect produced by the sparking of an induction coil. It had already been observed by other scientists that sparks sometimes jumped through the air between the terminals of an induction coil. You will recall (Chapter 15) that an induction coil can be used to produce high voltages if there are many more turns of wire on one side than the other. Ordinarily, air does not conduct electricity, but when there is a very large potential difference between two wires a short distance apart, a conducting pathway may be formed momentarily by ionization of the air molecules, and a short burst of electricity may pass through. We see a spark as visible evidence of this quick motion of charge. Hertz observed that when a piece of wire was bent around so that there was a short gap between its two ends, and held near an induction coil, a spark would jump across the air gap in the wire when a spark jumped across the terminals of the induction coil.

Each spark produced by an induction coil is actually a series of many sparks jumping rapidly back and forth between the terminals. Hertz could control the jumping frequency by changing the size and shape of the 16-inch square plates he used for terminals. He reasoned that as the sparks jump back and forth they must be setting up rapidly changing electric and magnetic fields in the air gap, and these fields, according to Maxwell's theory, will propagate through space as electromagnetic waves. (The frequency of the waves will be the same as the jumping frequency of the sparks.)

When the electromagnetic waves pass over the air gap in the bent piece of wire, they will set up rapidly changing electric and magnetic fields there. A strong electric field produces a spark in the air gap, just as a field originally produced a spark between the terminals of the induction coil. Since the field is rapidly changing, sparks will jump back and forth between the two ends of the wire. This wire serves as a detector of the electromagnetic waves generated by the induction coil.

If Hertz's interpretation of his experiment is correct, and if the detector is really receiving electromagnetic waves which have traveled through space from the induction coil, then there must be a short time delay between the two sparks. The spark in the detector cannot occur at exactly

*The radio and television "static" produced by sparking in electrical appliances and in the ignition of passing cars show that high frequency oscillations occur in sparks*

*An electric current oscillating at a very high frequency induces magnetic fields that are large compared to the ordinary magnetic field of the current. But circuits to produce such high frequency oscillations were not available in Maxwell's time.*

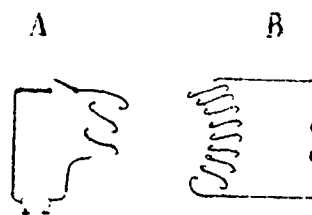

Starting and stopping the current in coil A with a vibrating switch produces a rapidly changing magnetic field in the iron core. This rapidly changing field induces high voltage peaks in the many-turn coil B.

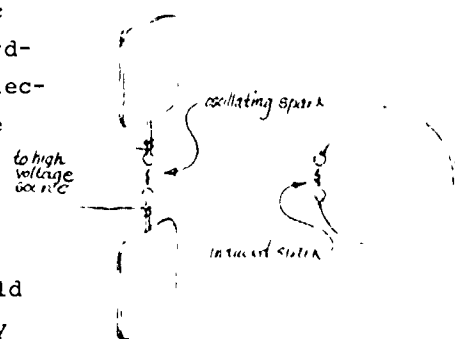

*The detecting loop must be resonant at the same frequency as the generator and lie in a plane parallel to the generating gap.*

A. A recorded research report





Heinrich Hertz (1857-1894) was born in Hamburg, Germany. During his youth he was mainly interested in languages and the humanities but became interested in science after a grandfather gave him some apparatus. Hertz did simple experiments in a small laboratory which he had fitted out in his home. After completing secondary school (and a year of military service) he undertook the serious study of mathematics and physics at the University of Berlin in 1878. In 1883 he devoted himself to the study of electromagnetism, including the recent work of Maxwell. Two years later he started his famous experiments on electromagnetic waves. During the course of this work, Hertz made another discovery—the photoelectric effect—which has had a profound influence on modern physics. We shall study this effect in Chapter 18 (Unit 5).

• The Crookes radiometer (Unit 3 Student Handbook) that rotates when illuminated is not a demonstration of radiation pressure.

Instead of oscillating sparks, modern electronic circuits produce oscillating currents in antenna wires.

the same instant as the spark in the induction coil because it takes a little time for the wave to go from one place to the other.

In 1888, Hertz was able to measure the speed of these electromagnetic waves and found that this speed, as Maxwell had predicted, is just the speed of light.

In subsequent experiments, Hertz showed that the electromagnetic radiation from his induction coil has all the usual properties of light waves. It can be reflected at the surface of a wall and by metallic conductors, and the angle of incidence is equal to the angle of reflection (see Sec. 13.3). The electromagnetic radiation can be focussed by a concave metallic mirror. It shows diffraction effects when it passes through an opening in a screen. It is refracted in passing through prisms of glass, wood, plastic and other non-conducting material.

Hertz's experiments provided dramatic confirmation of Maxwell's electromagnetic theory. They showed that electromagnetic waves actually exist, that they travel with the speed of light and that they have the familiar characteristics of light. There was now rapid acceptance of Maxwell's theory by mathematical physicists, who applied it with great success to the detailed analysis of a wide range of phenomena.

Maxwell also predicted that electromagnetic waves will exert a pressure on any surface that reflects or absorbs them. This pressure is very small, and experimentally it is extremely difficult to distinguish it from the pressure caused by air currents set up by heating of the surface that absorbs the waves. The technical difficulties involved in testing this prediction were not solved until 1899, when Lebedev in Russia and two years later, Nichols and Hull in the United States finally confirmed the existence of radiation pressure. They found that this pressure has exactly the value predicted by Maxwell's theory.

Thus, at the end of the nineteenth century, Maxwell's electromagnetic theory stood on the same level as Newton's laws of mechanics, as an established part of the foundations of physics.

- 
- Q6 What prediction of Maxwell's was verified by Hertz?
- Q7 What did Hertz use as a detector of electromagnetic waves?
- Q8 What second prediction of Maxwell's was later confirmed?
-

See article on "Microwave Optics" by C.L. Andrews in the February 1967 issue of The Physics Teacher, p.55.

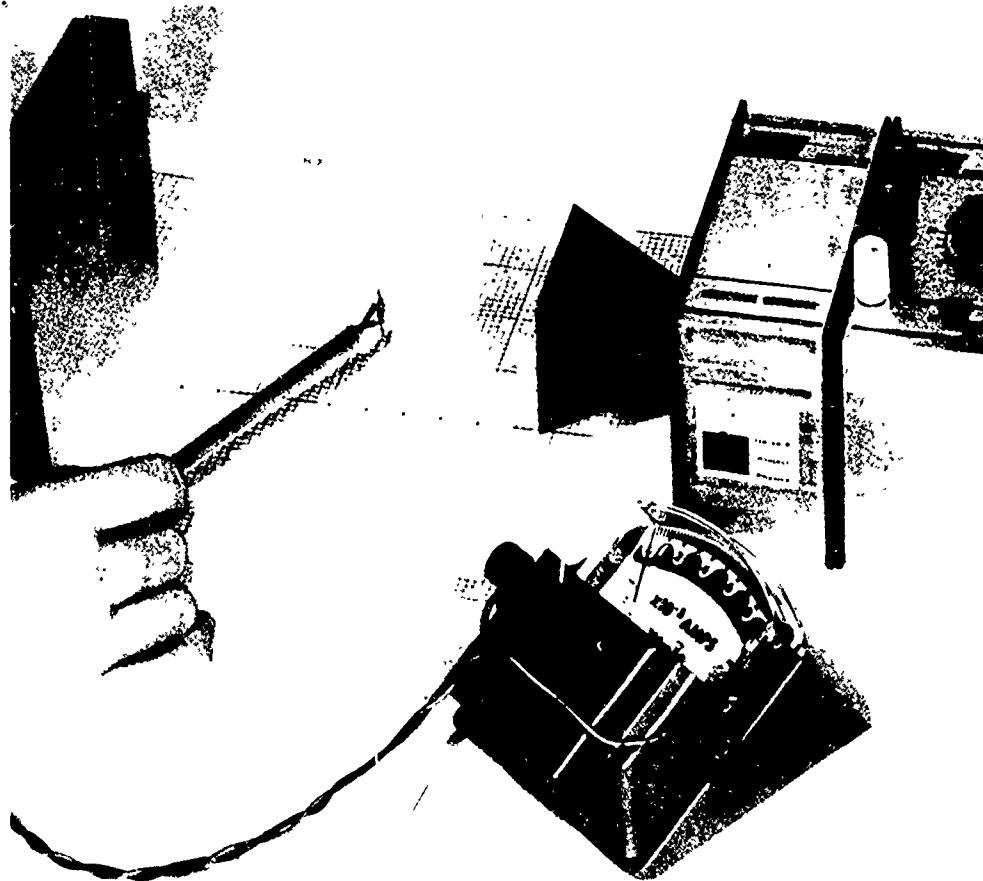
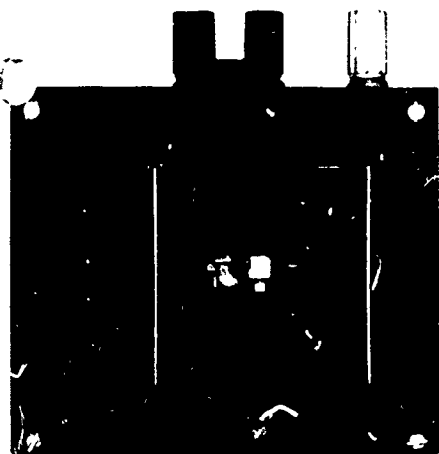

Electromagnetic radiation of a few centimeters wavelength is produced by oscillating electric fields inside the metal horn. Experiments with this radiation show phenomena similar to those observed for water and sound waves. Below are actual measurements of the intensity of a standing interference pattern in front of a flat reflecting surface. All these experiments can be done in your laboratory period.

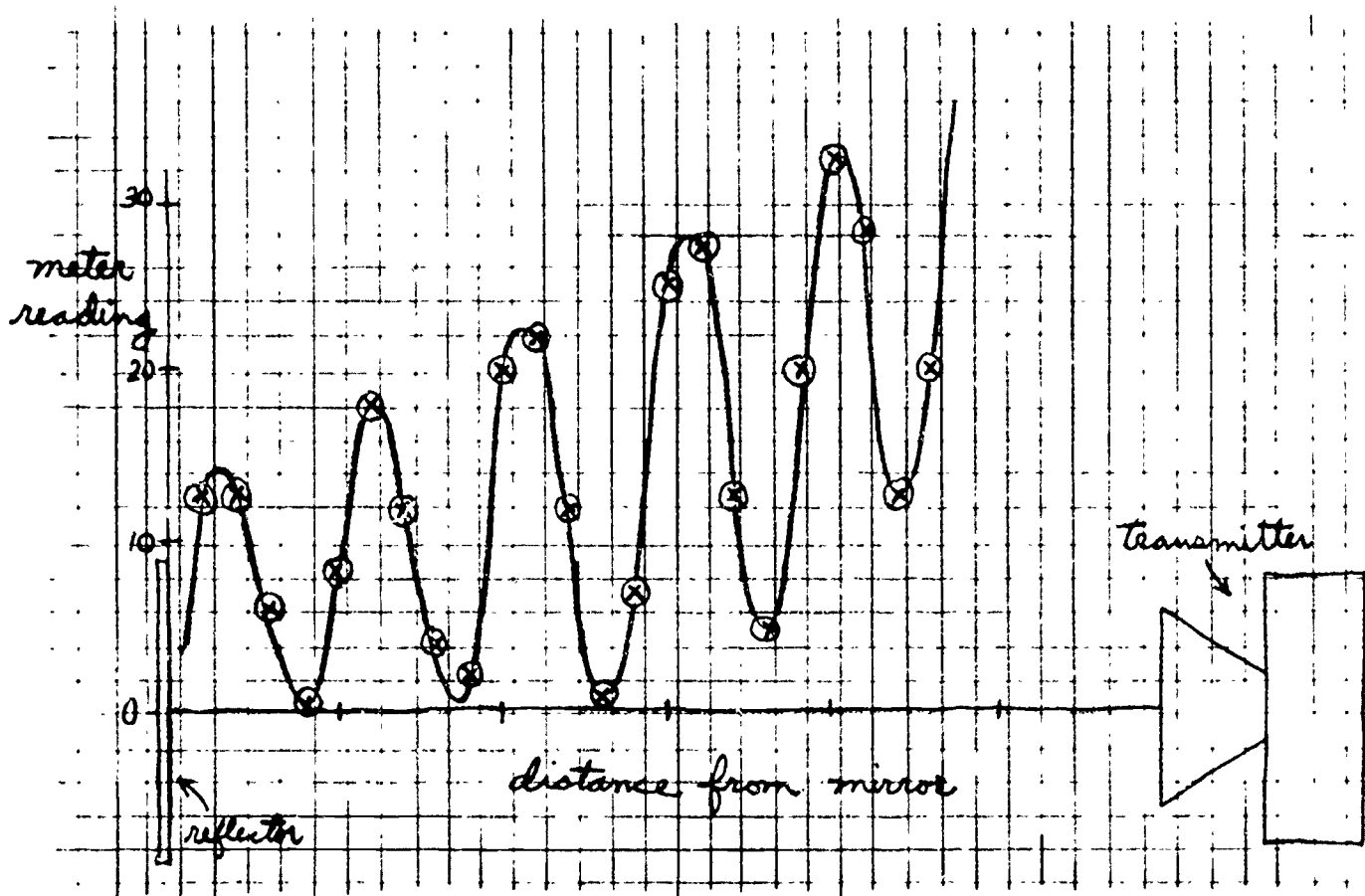

16.5 The electromagnetic spectrum. Hertz used radiation with a wavelength of about 1 meter, about a million times the wavelength of visible light. You might now ask: is this an isolated set of wavelengths or a small segment of a spectrum of much greater extent? Experiments show that there is a wide and continuous variation in the wavelength (and frequency) of electromagnetic waves; the entire possible range is called the electromagnetic spectrum. A range of frequencies from about 1 cycle/sec to  $10^{25}$  cycles/sec, corresponding to a wavelength range from about  $10^8$  meters to  $10^{-17}$  meters, has been studied and many frequency regions have been put to practical use.

The frequency unit "cycles/sec" is being replaced by the equivalent unit, the "Hertz." You will sometimes see the forms  $10^6$  Hertz,  $10^6$  cycles/sec,  $10^3$  kilocycles/sec, 1 megacycle/sec: all signifying the same frequency. Some FM radio stations now regularly give their frequencies in megahertz.

Light, heat, radio waves and x rays are names given to certain regions in the electromagnetic spectrum. Each of these names denotes a region in which radiation is produced or observed in a particular way. For example, light may be perceived through its effect on the retina of the eye, but to detect radio waves we need electronic equipment to select and amplify the signal. The named regions overlap; for example, some radiation is called "ultraviolet" or "x-ray" depending on how it is produced.

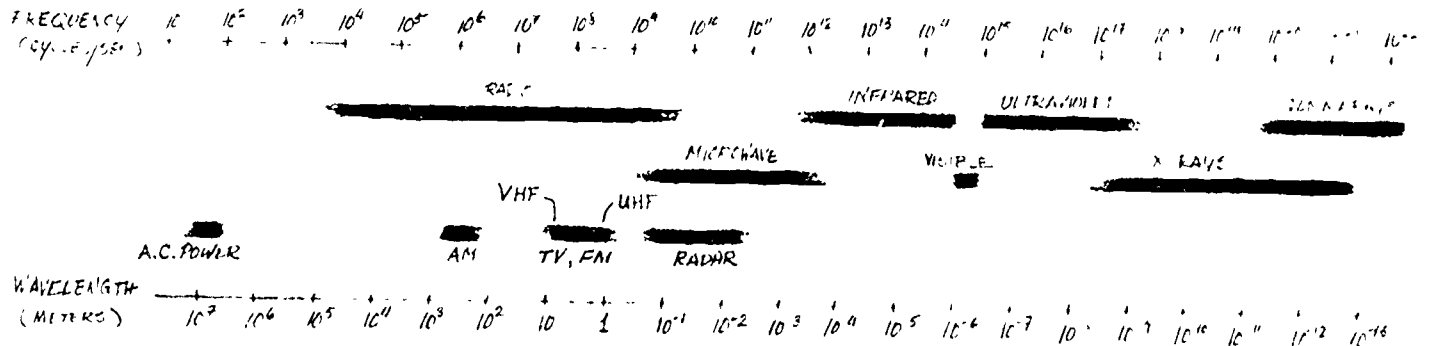

All the waves in the electromagnetic spectrum, although produced and detected in various ways, behave as predicted by Maxwell's theory. All electromagnetic waves travel through space at the same speed, the speed of light. They all carry energy; when they are absorbed the absorber is heated. Electromagnetic radiation, whatever its frequency, can be emitted only by a process in which energy is supplied to the source of radiation. There is now overwhelming evidence that electromagnetic radiation originates from accelerated charges. This acceleration may be produced in many ways: by heating materials to increase the vibrational energy of charged particles, by varying the charge on an electric conductor (an antenna), or by causing a stream of charged particles to change its direction. In these and other processes the work done by the force applied to the electric charges becomes the energy of radiation.

T 34: The electromagnetic spectrum

See "The Electronic Revolution" in Project Physics Reader 4.

Summary 16.5

Electromagnetic waves with frequencies from 1- $10^{25}$  cycles/sec have been studied and put to a variety of uses. Different ranges of frequency, many overlapping, are given different names (radio, infrared, visible, ultraviolet, x ray, gamma ray). Most of the behavior of these waves is predicted by Maxwell's electromagnetic field theory.

In December 1901 Guglielmo Marconi successfully detected radio waves sent from Newfoundland to Ireland. Marconi showed that long distance radio communication is possible and revealed the previously unsuspected layers of electric charge in the upper atmosphere.

165

See note on page 133 concerning DeForest.

Radio. Electromagnetic waves of frequencies of  $10^4$  to  $10^7$  cycles/sec are efficiently reflected by electrically charged layers in the upper atmosphere. This reflection makes it possible for radio waves to be detected at great distances from the source. Radio signals have wavelengths from tens to thousands of meters. Such waves can easily diffract around relatively small obstacles such as trees or buildings, but large hills and mountains may cast severe shadows.



A Looking inside a radio tube

Radio waves that can traverse large distances, either directly or by relay, are very useful for conveying information. Communication is accomplished by changing the signal in some way following an agreed code that can be deciphered by the recipient. The first radio communication was achieved by turning the signal on and off in the agreed pattern of the Morse code. Later the amplitude of the signal was varied in accordance with the tones of speech or music. Still later the frequency of the signal was varied. In broadcast radio and television the decoding is done in the receiver and the loudspeaker or TV picture tube, so that the message takes the same form at the receiver that it had at the transmitter.



carrier wave

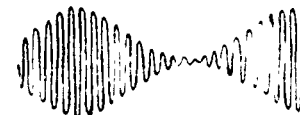

AM: information conveyed by amplitude modulation (variation) of the carrier

Because electromagnetic signals can interfere with one another it is necessary to limit their transmission. The International Telecommunication Union (ITU) controls radio transmission and other means of international communication. Within the United States, the Federal Communications Commission (FCC) is the government agency that regulates radio transmission. In order to reduce the interference of one signal with another, the FCC assigns suitable frequencies to radio stations, limits their power or sometimes the power radiated in particular directions, and often restricts the hours of transmission.



FM: information conveyed by frequency modulation (variation) of the carrier

Television and radar. Television and FM broadcasting stations operate at frequencies of about  $10^8$  cycles/sec or wavelengths of about one meter. These frequencies are not reflected by the layers of electric charge in the upper atmosphere; the signals travel in nearly straight lines and pass into space instead of following the curvature of the earth. Coaxial cables or relay stations are necessary to transmit signals between points on the earth separated by more than about 50 miles. Signals can be transmitted from one continent to another by relay satellites.

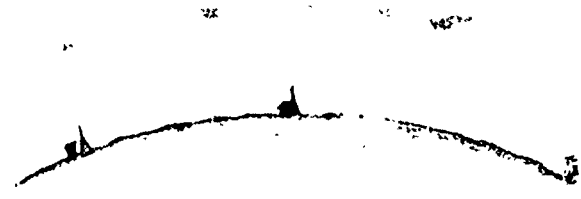

An important principle in radio transmission and detection is that of the resonant or "tuned" circuit. Reference to this can be found in the "Radio Amateur's Handbook" or basic texts listed in most radio supply catalogues, eg., Allied Radio.

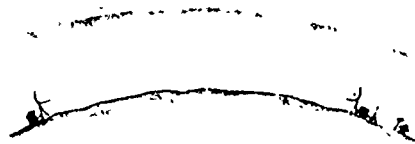

Satellites are used to relay microwaves all over the world. The microwaves can carry TV or telephone information.

These meter wavelength signals do not pass around objects, such as cars, ships, or aircraft, which have dimensions of several meters. The interference with the direct waves that results from reflection of these waves by passing airplanes can produce a very noticeable and annoying movement and flicker of the television picture. Signals of wavelength from one meter down to as short as one millimeter are used to detect aircraft and ships. If the transmission takes the form of pulses, the time from the radiation of a pulse to the reception of its echo measures the distance of the reflecting object. This technique is called Radio Detection And Ranging, or RADAR. When a large antenna is used with waves of very short wavelength, a sharp beam like that of a searchlight can be produced. From the reflection of a sharp beam that is pulsed both the direction and distance of an object can be measured.

Infrared radiation. Electromagnetic waves with wavelengths from  $10^{-1}$  to  $10^{-4}$  meters are often called microwaves. It is difficult to construct circuits that oscillate at frequencies high enough to produce these waves. However, electromagnetic waves shorter than about  $10^{-4}$  meters are emitted copiously by the atoms of hot bodies. This "radiant heat" is usually called infrared, because most of the energy is in the wavelengths slightly longer than the red end of the visible band of radiation. While associated mainly with heat radiation, they do have some properties which are the same as those of visible light. The shorter infrared waves affect specially treated photographic film, and photographs taken with infrared radiation show some interesting effects. Since scattering by small particles in the atmosphere is very much less for long wavelengths (Sec. 13.6), infrared will penetrate smoky haze dense enough to block visible light.



A photo taken in Utah with film sensitive only to infrared.

Visible light. The visual receptors in the human eye are sensitive to electromagnetic radiation with wavelengths between about  $7 \times 10^{-7}$  and  $4 \times 10^{-7}$  meters. Radiation of these wavelengths is usually called "light," or more explicitly, "visible light." The peak sensitivity of the

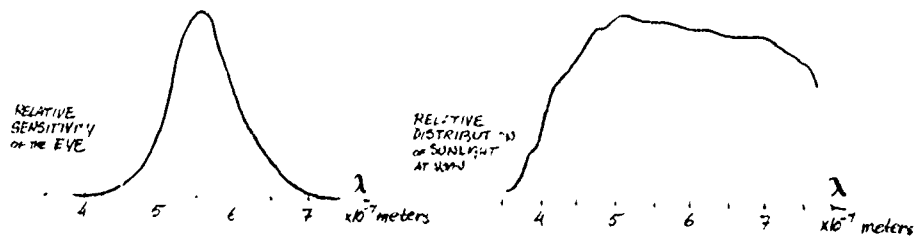

eye is in the green and yellow, roughly the same as the peak of solar radiation which reaches the earth's surface.



Ultraviolet light. Electromagnetic waves shorter than the visible violet are called ultraviolet. The ultraviolet region of the spectrum is of great interest to the spectroscopist because it includes the radiation characteristic of many kinds of atoms. Of more general interest is its ability to cause many kinds of photochemical reactions in which radiant energy is converted directly into chemical energy. Typical of these reactions are those which occur in silver bromide in the photographic process, in the production of ozone in the upper atmosphere and in the production of the dark pigment, known as melanin, in the skin.

X rays. This radiation (wavelengths from about  $10^{-8}$  meters to  $10^{-17}$  meters) is commonly produced by the sudden deflection or stopping of electrons when they strike a metal target. The maximum frequency of the radiation generated is determined by the energy with which the electrons strike the target, which is determined by the voltage through which they are accelerated (Sec. 14.8). So the maximum frequency increases with the accelerating voltage. The "harder" the x rays (the higher the frequency), the greater is their penetration of matter. The distance of penetration also depends on the nature of the material penetrated. X rays are quite readily absorbed by bone (which contains calcium), whereas they pass much more readily through lower density organic matter (such as flesh) containing mainly the light atoms hydrogen, carbon and oxygen. This fact, combined with the ability of x rays to affect a photographic plate, leads to some of the medical uses of x-ray photography. Because x rays can damage living cells they should be used with great caution and only by trained technicians. Some kinds of diseased cells are injured more easily by x rays than are healthy cells, and so carefully controlled x-ray beams can be used in therapy to destroy cancer or other harmful cells.

X rays produce interference effects in a special type of reflection which occurs when they fall on a crystal, in which atoms and molecules are arranged in a regular pattern. Successive reflections from crystal planes (parallel planes containing substantial numbers of atoms) lead to an interference pattern which can be used in either of two ways. If the spacing of the atoms in the crystal is known, the wavelength of the x rays can be calculated. Conversely, if the x-ray wavelength is known, the distance between crystal planes, and thus the structure of the crystalline substance, can be determined. X rays are now widely used by chemists and mineralogists seeking information about crystal structure.

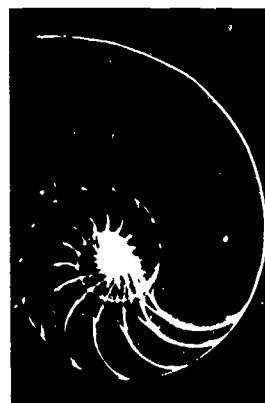

An x-ray photo of a chambered nautilus sea shell.

*The basis for this is, of course, that the distance between molecules is roughly the same as the x-ray wave lengths ( $\sim 10^{-10}$  meters).*

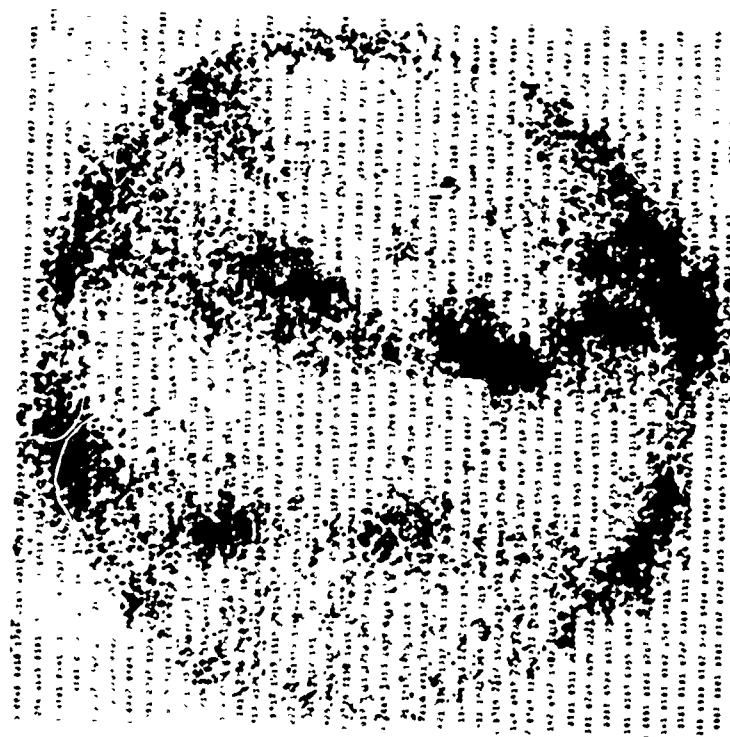
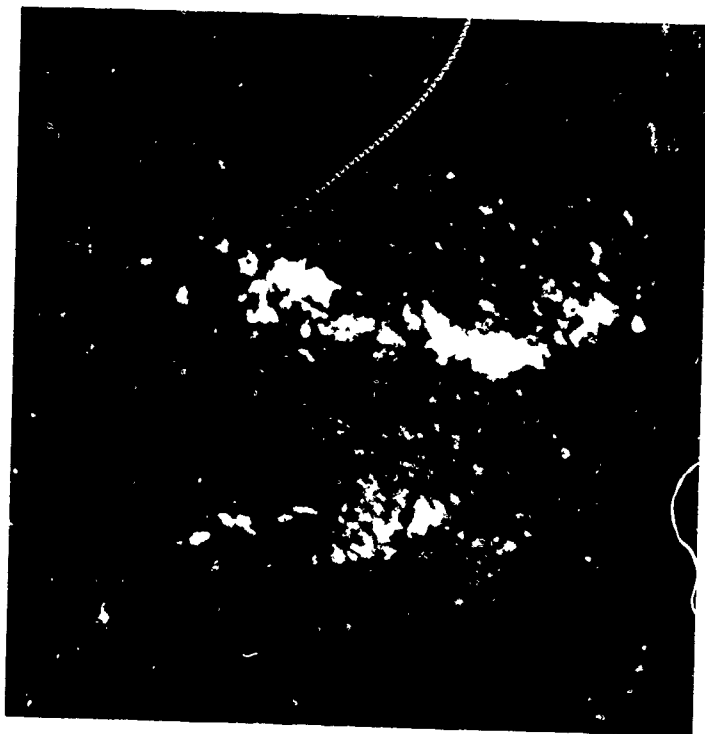

### Astronomy Across the Spectrum

Electromagnetic radiation of different wavelengths brings us different kinds of information. Above are two views of the sun on Oct. 25, 1967; at the left is a photo taken in violet light; at the right is a computer plot of intensity of very short ultraviolet emission. The UV doesn't penetrate the earth's atmosphere; the information displayed here was collected by the Orbiting Solar Observatory satellite shown at the right. Below are three views of the sun on Mar. 17, 1965. At the left is a photograph in red light; at the

right is an image formed by x rays; on the next page is an intensity contour map made from the image. The x-ray telescope was raised above the earth's atmosphere by an Aerobee rocket.

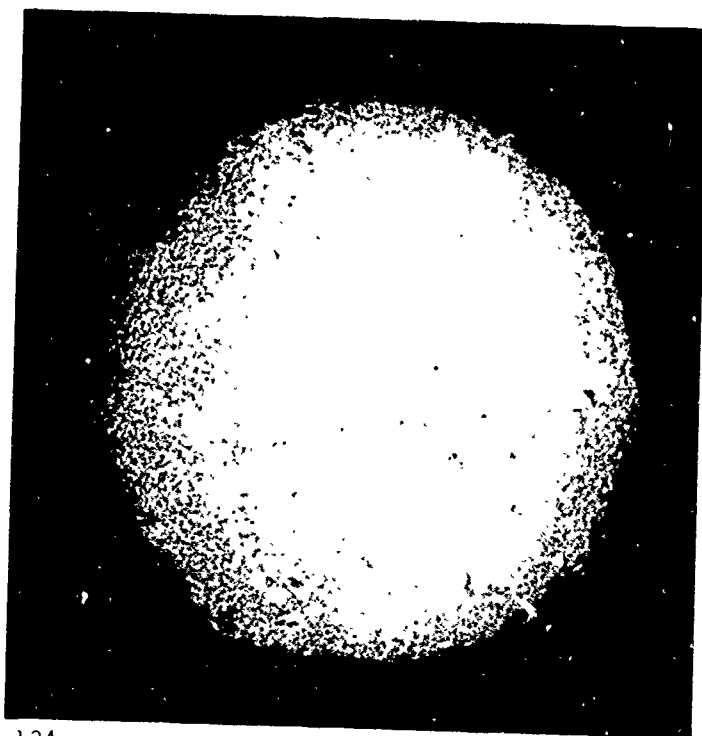
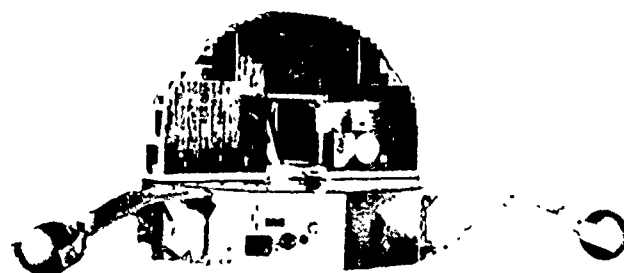



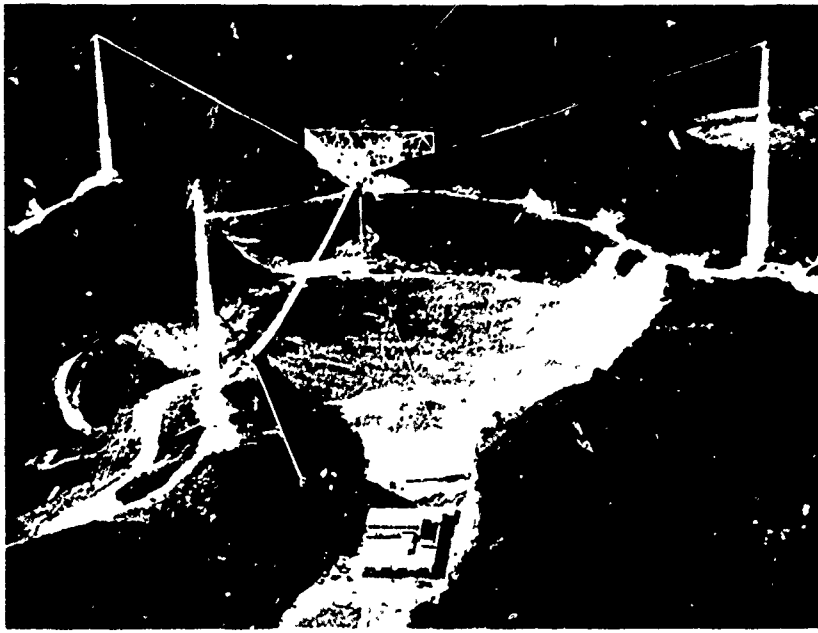

Longer wavelength radiations such as radio and infrared are able to penetrate interstellar dust. Radio telescopes come in a great variety of shapes and sizes. Above is shown the huge Arecibo telescope in Puerto Rico; it has a fixed reflector but a moveable detector unit. To the right are a photograph and a diagram of a precise steerable antenna, the Haystack antenna in Massachusetts. Information collected with this instrument at 3.7 cm wavelength led to the upper contour map at right. This map of radio brightness is of the portion of the sky around the center of our galaxy; the area covered is about that of the full moon. The infrared brightness of the same portion of sky is shown in the bottom contour map.

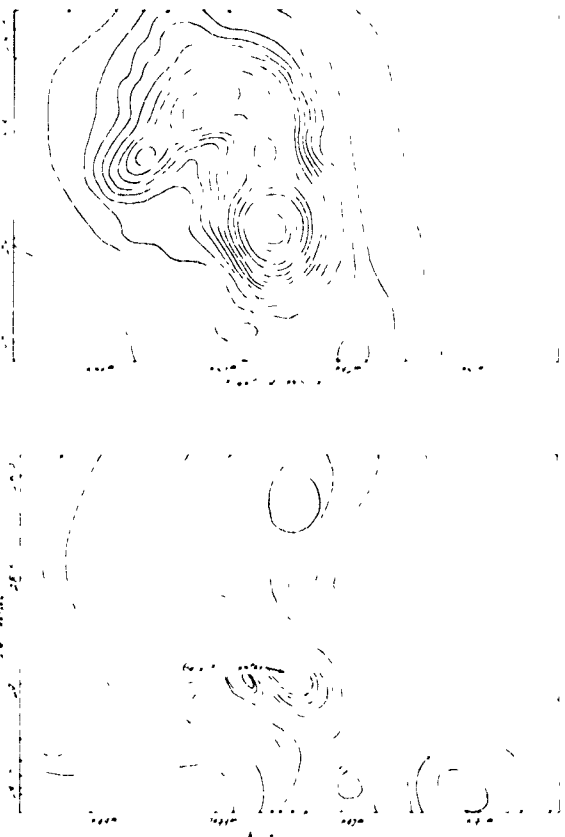



The glow in the photograph is caused when gamma rays emitted by radioactive cobalt cylinders interact with the surrounding pool of water.

Gamma rays. The gamma-ray region of the electromagnetic spectrum coincides with the x-ray region. Gamma radiation is emitted by the unstable nuclei of natural or artificial radioactive materials. We shall return to considering gamma rays in Unit 6.

- 
- Q9 Why are radio waves not much affected by obstacles such as trees or buildings?
- Q10 Why are relay stations often needed in transmitting television signals?
- Q11 How is the frequency of x rays related to their penetration of matter?
- Q12 How do the wavelengths used in RADAR compare to the wavelengths of visible light?
- Q13 How does the production of x rays differ from that of gamma rays?
- 

**16.6 Maxwell: intellectual characteristics and attitudes.** The capacity of Maxwell's electromagnetic theory to relate diverse discoveries over the broad frequency range of the electromagnetic spectrum is striking evidence of the importance and scope of his accomplishment. Let us consider some of the qualities of Maxwell's intellect that contributed to his success in carrying through his grand work.

Maxwell's way of thinking about scientific problems was an effective joining of the concrete with the abstract. He was quick to see and grasp the essential physical features of the problems he attacked. His intuition developed from a practice he began as a boy of studying the operation of mechanisms, from a toy top to a commercial steam engine, until he had satisfied his curiosity about how they worked. On the abstract side, his formal studies, begun at the Academy in Edinburgh and continued through his work as an undergraduate at Cambridge, gave Maxwell experience in using mathematics to develop useful parallels among apparently unrelated occurrences.

Within two years after receiving his bachelor's degree, Maxwell demonstrated his exceptional ability to fuse these two elements. His paper "On Faraday's Lines of Force" gave mathematical form to a physical model. His prize-winning essay "On the Stability of the Motion of Saturn's Rings" was a mathematical analysis of several mechanical models by which he proved that only one model of the ring material could account for the stability of the rings.

Although Maxwell's theories were his greatest contributions to science, he did important experimental work on color, on

#### Summary 16.6

SG 16 23

Maxwell's skill at applying mathematical abstractions to well-conceived mechanical models was an important source of his success. Maxwell emphasized the value of working at both theory and experiment and the importance of the historical study of significant works of science.

"A great French philosopher, one of those who have most completely fathomed Maxwell's work, said to me once, "I understand everything in the book except what is meant by an electrically charged body."

POINCARÉ, 1885.

1) The whole of the third...

The whole of the third...

2) The whole of the third...

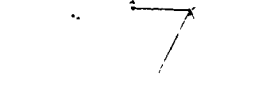

The whole of the third...

The whole of the third...

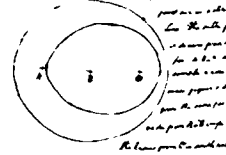

The whole of the third...



The whole of the third...

James Clerk Maxwell (1831-1879) was born in Edinburgh, Scotland in the same year Faraday discovered electro-magnetic induction. Unlike Faraday, Maxwell came from a well-off family, and was educated at the Edinburgh Academy and the University of Edinburgh. He showed a lively interest in how things happened when he was scarcely three years old. As a child he constantly asked, "What's the go of that?". While Maxwell was still at the Edinburgh Academy, he wrote a paper on "Oval Curves," and a summary of this paper was published in the Proceedings of the Royal Society of Edinburgh when he was only fourteen years old. By the time he was seventeen he had published three papers on the results of his original research. In 1850 he went to the University of Cambridge in England. In 1856 he became Professor of Physics at the University of Aberdeen in Scotland. He was one of the main contributors to the kinetic theory of gases and to two other important branches of physics, statistical machines and thermodynamics. His greatest achievement was his electromagnetic theory. Because of his tremendous contributions, Maxwell is generally regarded as the greatest physicist between the time of Isaac Newton and that of Albert Einstein.



the viscosity of gases, and in electricity and magnetism. Maxwell was a strong believer in the value to the scientist of working at both theory and experiment.

There is no more powerful method for introducing knowledge into the mind than that of presenting it in as many different ways as we can. When the ideas, after entering through different gateways, effect a junction in the citadel of the mind, the position they occupy becomes impregnable. ...It is therefore natural to expect that the knowledge of physical science obtained by the combined use of mathematical analysis and experimental research will be of a more solid, available, and enduring kind than that possessed by the mere mathematician or the mere experimenter.

In addition to working at physics itself, Maxwell was an active analyst of the methods of scientists and of the ways in which scientific knowledge progresses. He recommended the historical study of original works of science, believing that

It is of great advantage to the student of any subject to read the original memoirs on that subject, for science is always most completely assimilated when it is in the nascent state...

Many of Maxwell's papers begin with reviews of earlier work that show the care with which he studied the history of his subject. Maxwell asserted that it was important for the scientist to know, through examples, the value of different scientific methods. In addition to studying procedures that have succeeded, the scientist should study those that have failed.

But the history of science is not restricted to the enumeration of successful investigations. It has to tell of unsuccessful inquiries, and to explain why some of the ablest men have failed to find the key to knowledge, and how the reputation of others has only given a firmer footing to the errors into which they fell.

At a time when other physical scientists were saying that a mechanical explanation for physical experience was nearly complete, Maxwell saw new possibilities for scientific explanation and enlarged opportunities for scientific speculation. As with the Newtonian synthesis, a stimulating period of application and extension of Maxwell's new field theory followed. The theory of relativity (1905) put Maxwell's work in a new and wider framework. But eventually results accumulated that did not fit Maxwell's theory; something more was needed. In 1925, after a quarter century of discovery and improvisation, the development of the quantum

See "James Clerk Maxwell, Part II" and "Maxwell's Letters: A Collection" in Project Physics Reader 4.

*A: Bell telephone science kits.*

theory led to an enlarged synthesis that included Maxwell's electromagnetism.

Q14 What value did Maxwell see in a scientist working at both theory and experiment?

Q15 What did he think important to study in the history of science?

167

"The greatest and noblest pleasure which men can have in this world is to discover new truths; and the next is to shake off old prejudices."

FREDERICK THE GREAT,  
eighteenth century.

16.7 What about the ether? The luminiferous ether had been postulated specifically to serve as a medium for the propagation of light waves. Maxwell found that the same ether could also be used to transmit electric and magnetic forces. Just before his death in 1879, Maxwell wrote an article for the Encyclopaedia Britannica, in which he supported the ether concept.

Whatever difficulties we may have in forming a consistent idea of the constitution of the aether there can be no doubt that the interplanetary and interstellar spaces are not empty, but are occupied by a material substance or body, which is certainly the largest, and probably the most uniform body of which we have any knowledge....

Maxwell was aware of the failures of earlier ether theories. Near the beginning of the same article he said:

Aethers were invented for the planets to swim in, to constitute electric atmospheres and magnetic effluvia, to convey sensations from one part of our bodies to another, and so on, till all space had been filled three or four times over with aethers. It is only when we remember the extensive and mischievous influence on science which hypotheses about aethers used formerly to exercise, that we can appreciate the horror of aethers which sober-minded men had during the 18th century...

Why, after he had succeeded in formulating his electromagnetic theory in a way that made it independent of any detailed model of the ether, did Maxwell continue to speak of the "great ocean of aether" filling all space?

Like other great men, Maxwell could go only so far in changing his view of the world. It was almost unthinkable that there could be vibrations without something that vibrates—that there could be waves without a medium. The verb "to wave" must have a subject: the ether. Similarly, to many nineteenth-century physicists the idea of "action at a distance" seemed absurd. How could one object exert a force on another body far away if something did not transmit the force? One body is said to act on another, with the word on conveying the idea of contact. Thus, according to accepted ways of describing the world using the common language, the postulate of the ether seemed necessary.

#### Summary 16.7

Maxwell's electromagnetic theory, together with the failure of all attempts to detect any motion of the earth through the ether, helped to undermine the general belief in the existence of an ether. The success of Einstein's extension of the principle of relativity to include both mechanics and electromagnetism led scientists to abandon the ether concept. The mechanical models of light and electricity served as a scaffolding for constructing a field theory that then provided its own support.

"The more important fundamental laws and facts of physical science have all been discovered, and these are now so firmly established that the possibility of their ever being supplanted in consequence of new discoveries is exceedingly remote. "Our future discoveries must be looked for in the sixth place of decimals."

MICHELSON, 1899.

The possibility that the ether near the earth is dragged along by the earth was also considered. This possibility was found to be inconsistent with telescopic observations of stars (aberration of light).

Michelson first tried the experiment in 1881, stimulated by a letter of Maxwell's published just after Maxwell's death.

167

Yet twenty-five years after Maxwell's death the ether concept had lost much of its support, and within another decade, it was dropped from the physicists' collection of useful concepts.

In large part, the success of Maxwell's theory, with its indifference to details of the ether's constitution, helped to undermine the general belief in the existence of an ether. Maxwell's equations could be considered to give the relations between changes of electric and magnetic fields in space without making any reference to the ether.

Another reason for skepticism about the existence of the ether was the failure of all attempts to detect the motion of the earth with respect to the ether. If light is a kind of vibration of the ether, then light should travel at a definite speed relative to the ether. But it seemed reasonable to assume that the earth is moving through the ether as it makes its annual orbit around the sun. Under these conditions the speed of light should be observed to differ, when the earth and the light are moving in the same direction through the ether, from the speed when the earth and light are moving in opposite directions through the ether. An analogous effect is observed with sound waves that go faster with respect to the earth when traveling in the direction of the wind than they do when traveling against the wind.

When the time for light to make a round trip with and against the ether wind is computed and compared with the time calculated for a round trip in the absence of an ether wind, the expected time difference is found to be very small: only  $10^{-15}$  seconds for a round trip of 30 meters. Although this is too short a time difference to measure directly, it is of the same order as the time for one vibration of visible light and might be detected from observations of an appropriately produced interference pattern. In 1887 the American scientists Michelson and Morley used a specially designed interferometer that was sensitive enough to measure an effect only one per cent as great as that expected on the basis of the ether theory. Neither this experiment nor the many similar experiments done since then have revealed an ether.

In an attempt to preserve the idea of an ether, supporters of the ether concept offered various explanations for this unexpected negative result. For example, they even suggested that objects moving at high speeds relative to the ether might change their size in just such a way as to make this relative speed undetectable.



The conclusive development that led scientists to forego the ether concept was not a definitive experiment, but a brilliant argument by a young man of 26 years to the effect that a deep union of mechanics and electromagnetism could be achieved without the ether model. The man was Albert Einstein. A few remarks here describing his accomplishment will provide a setting for your study of Einstein's work now or at a later time. (More on relativity theory appears in Chapter 20 and Project Physics Reader 5.)

In 1905, Einstein showed how the laws of electromagnetism satisfy the same principle of relativity that holds for mechanics. The Galilean principle of relativity (Sec. 4.4) states that the same laws of mechanics apply in each of two frames of reference which have a constant relative velocity. Thus it is impossible, according to this principle, to tell by any kind of mechanical experiment whether or not one's laboratory (reference frame) is at rest or is moving with constant velocity. The principle is illustrated by the common experience that within a ship, car, plane or train moving at a constant speed in a straight line, the observer finds that objects move, or remain at rest, or fall or respond to applied forces in just the same way they do when these conveyances are at rest. Galileo, a convinced Copernican, used this principle to account for the common experience that the motion of objects with respect to the earth gives no indication that the earth itself is in motion about the sun

In his 1905 paper Einstein considered what would happen if this principle of relativity applied to all of physics, including electromagnetism. He assumed that the speed of light in free space is the same for all observers, even when they are moving relative to each other or relative to the light sources. With this bold assumption Einstein rejected the ether and all other attempts to provide a preferred frame of reference for light. The price to be paid for making this assumption, Einstein showed, was the necessity of revising some commonly held and hence common-sense notions of space and time. By making these revisions, Einstein demonstrated that Maxwell's equations are fully consistent with the principle of relativity. As scientists came to recognize how the extension of the relativity principle to electromagnetism fitted the observed behavior of light and led to useful new ideas about mass and energy, they rejected the idea of the ether. Some of the important consequences of Einstein's theory of relativity will be discussed in Unit 5.



Einstein in 1912

### *A: Good reading*

See Einstein's essay "On The Method of Theoretical Physics" in Project Physics Reader 4.



What was the role played by the elaborate array of ethers, vortices and other mechanical models that the nineteenth-century physicists used? It would certainly be unjust to say that the mechanical models were useless, since they guided the work of Maxwell and others and had astonishingly useful by-products in contributing to an understanding of the elastic properties of matter. We should consider the mechanical models of light and electricity as the scaffolding which is used to erect a building; once the building is completed, providing the construction is sound, the scaffolding can be torn down and taken away.

Indeed the whole conception of explanation by means of mechanism, while intuitively persuasive, has been found insufficient and has been abandoned. Important developments in twentieth-century physics that have demonstrated the inadequacy of mechanical explanation will be discussed in Units 5 and 6.

---

Q16 Why did Maxwell and others cling to the concept of an ether?

Q17 Whose argument finally made the ether an unnecessary hypothesis?

---

In this chapter you have read about how mechanical models of light and electromagnetism faded away, leaving a model-less mathematical field theory. The situation might be likened to that of the Cheshire Cat, in a story written by the Reverend Charles Dodgson, a mathematics teacher at Oxford, in 1862:

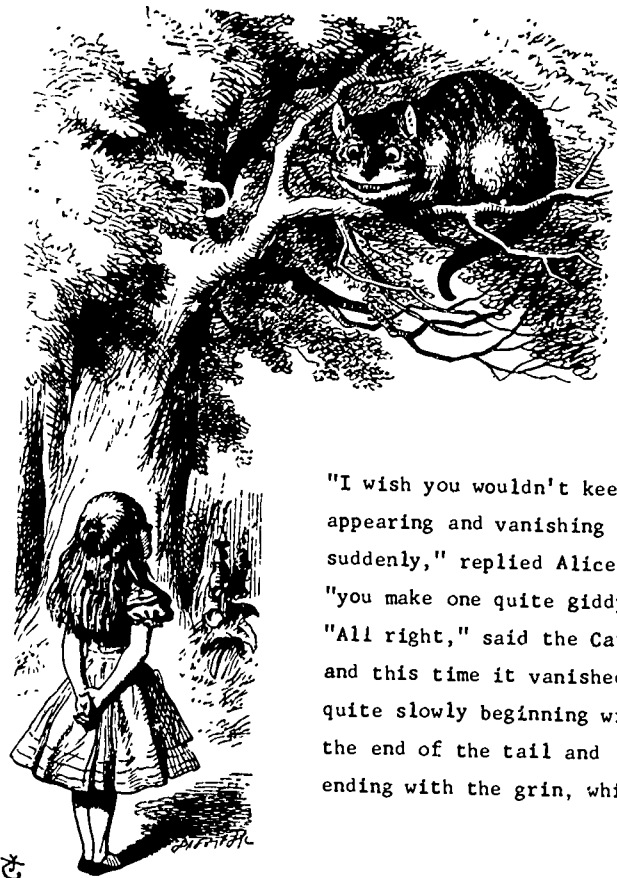

"I wish you wouldn't keep appearing and vanishing so suddenly," replied Alice, "you make one quite giddy."  
 "All right," said the Cat; and this time it vanished quite slowly beginning with the end of the tail and ending with the grin, which

"DeForest has said in many newspapers and over his signature that it would be possible to transmit the human voice across the Atlantic before many years. Based on these absurd and deliberately misleading statements, the misguided public, Your Honor, has been persuaded to purchase stock in his company."

Extract from the record of the trial of LEE DEFOREST in 1912.

In 1914 the first transatlantic telephone message was sent through the use of a development of DeForest's vacuum tube

remained some time after the rest of it had gone. "Well! I've often seen a cat without a grin," thought Alice, "but a grin without a cat! It's the most curious thing I ever saw in my life!"

(Alice's Adventures in Wonderland. Chapter VI)





- 16.1 What inspired Oersted to look for a connection between electricity and magnetism? *The idea that all physical phenomena are different forms of the same basic force*
- 16.2 A current in a conductor can be caused by a steady electric field. Can a displacement current in an insulator be similarly caused? Explain your answer briefly. *No*
- 16.3 How is an electromagnetic wave initiated and propagated? *Accelerating charge and mutual induction*
- 16.4 What is the "disturbance" that travels in each of the following waves:  
a) water waves, *height*  
b) sound waves, *pressure & density*  
c) electromagnetic waves? *field strength*
- 16.5 If the velocity calculated from experiments measuring the charge on a capacitor is the same as the velocity of light, how do you account for the difference between 310,740,000 meters/sec and 314,858,000 meters/sec? *Uncertainty of measurement*
- 16.6 In Hertz's detector, it is the electric field strength in the gap between the ends of the wire ring that makes the sparks jump. How could Hertz show that the waves were vertically polarized? *Detector orientation*
- 16.7 What evidence did Hertz obtain that the sparking of his induction coil generated waves having many similar properties to light waves? *About same speed, etc*
- 16.8 Give several factors that contributed to the twenty-five year delay in the general acceptance by scientists of Maxwell's electromagnetic wave theory. *discussion*
- 16.9 What evidence is there for believing that electromagnetic waves carry energy? *Heating by absorption, etc*
- 16.10 What is the wavelength of an electromagnetic wave generated by the 60 cycles/sec alternating current in power lines?  *$5 \times 10^6$  m*
- 16.11 How short are "short-wave" radio waves? (Look on the dial of a short-wave radio.) *10 to 100 meters*
- 16.12 Electric discharges in sparks, neon signs, lightning, and some atmospheric disturbances produce radio waves. The result is "static" or noise in radio receivers. Explain why FM radio is almost static-free. *FM not sensitive to changes in signal amplitude.*
- 16.13 Why is there federal control on the broadcast power and direction of radio and TV stations, but no comparable controls on the distribution of newspapers and magazines? *Only a limited number of stations can operate without disturbing the reception of one another*
- 16.14 What information about earth-people would be available to extraterrestrial beings? *FM and TV broadcasts, visible light, but not AM*
- 16.15 Why can radio waves be detected at greater distances than the waves used for television and FM broadcasting? *Reflection from ionosphere.*
- 16.16 The ideal relay satellite would have a 24-hour orbit. What would the radius of such a "synchronous" orbit be? (Refer to Unit 2 for whatever principles or constants you need.) *27,900 mi.*
- 16.17 Explain why airplanes passing overhead cause "flutter" of a TV picture. *Changing phase differences of reflected and direct signals.*
- 16.18 From the answers to questions 16.12 and 16.17, how do you think the TV picture information is carried? How is the TV sound information carried? *AM; FM*
- 16.19 How much time would elapse between the sending of a radar signal to the moon and the return of the echo? *2.6 sec.*

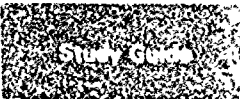

16.20 Refer to the black-and-white photograph on p. 122 that was taken using film sensitive only to the infra-red. How do you account for the appearance of the trees, clouds and sky?

*leaves reflect infrared strongly, sky is cold and scatters little infrared.*

16.21 What do you think is the reason that the eye is sensitive to the range of wavelengths that it is?

*Evolution ... Divine design*

16.22 A sensitive thermometer placed in different parts of the visible spectrum formed by a quartz prism will show a rise in temperature. This shows that all colors of light produce heat when absorbed. But the thermometer also shows an increase in temperature when its bulb is in either of the two dark regions beyond the end of the spectrum. Why is this?

*UV and IR*

16.23 For each part of the electromagnetic spectrum discussed in Sec. 16.5, list the ways in which you have been affected by it. Give examples of things you have done with radiation in that frequency range, or of effects it has had on you.

*Seeing, cooking, dental x-rays, heating, tanning, radio and TV, etc*

16.24 What reason did Maxwell give for studying original scientific memoirs? Do you agree with his statement?

*Discussion*

16.25 What is a principal reason for the loss of support for the ether concept?

*was not used in Maxwell's mathematical theory.*

16.26 At many points in the history of science the "natural" or "intuitively obvious" way of looking at things has changed radically. Our attitudes toward action-at-a-distance are a case in point. What are some other examples?

*discussion*

16.27 Can intuition be educated? That is, can our feelings about what the fundamental aspects of reality are be changed? Use attitudes taken toward action-at-a-distance or the ether as examples.

*Good luck*

16.28 Explain the analogy of the cat-less grin given at the end of Ch. 16.

*Body : mechanical models*

*Grin : Maxwell's equations*

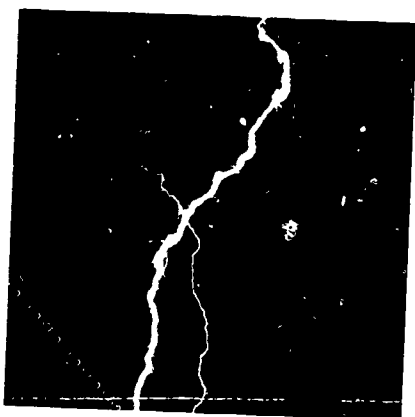

**Epilogue** We have seen how scientists sought to make light and electromagnetism comprehensible by devising models. The particle model accounted for the behavior of light by showing that moving particles, on experiencing strong forces at a boundary, will be bounced back or swerved in just the direction light is observed to be reflected and refracted. The wave model accounted for these and other effects by treating light as transverse waves in a continuous medium. Since there are material particles (sand grains, pebbles, projectiles) and waves (on strings, in water, etc.) that can be observed in action, these models provided a substantial, mechanical analogy for light corpuscles and light waves.

The same approach through mechanical analogy worked, up to a point, in explaining electricity and magnetism. Both Faraday and Maxwell made use of mechanical models for electric and magnetic lines of force. Maxwell used these models as clues and guides to the development of a mathematical theory of electromagnetism that, when completed, went well beyond the models. The electric and magnetic fields of Maxwell's theory cannot be made to correspond to the parts of any mechanical model. Is there, then, any way we can picture a field? Here is the response of the Nobel Prize-winning American physicist Richard Feynman:

I have asked you to imagine these electric and magnetic fields. What do you do? Do you know how? How do I imagine the electric and magnetic field? What do I actually see? What are the demands of scientific imagination? Is it any different from trying to imagine that the room is full of invisible angels? No, it is not like imagining invisible angels. It requires a much higher degree of imagination to understand the electromagnetic field than to understand invisible angels. Why? Because to make invisible angels understandable, all I have to do is to alter their properties a little bit—I make them slightly visible, and then I can see the shapes of their wings, and bodies, and halos. Once I succeed in imagining a visible angel, the abstraction required—which is to take almost invisible angels and imagine them completely visible—is relatively easy. So you say, "Professor, please give me an approximate description of the electromagnetic waves, even though it may be slightly inaccurate, so that I too can see them as well as I can see almost invisible angels. Then I will modify the picture to the necessary abstraction."

I'm sorry that I can't do that for you. I don't know how. I have no picture of this electromagnetic field that is in any sense accurate. I have known about the electromagnetic field a long time—I was in the same position 25 years ago that you are now, and I have had 25 years of experience thinking about these wiggling waves. When I start describing the magnetic field moving through space,

I speak of the E- and B-fields and wave my arms and you may imagine that I can see them. I'll tell you what I see. I see some kind of vague shadowy, wiggling lines—here and there is an E and B written on them somehow, and perhaps some of the lines have arrows on them—an arrow here or there which disappears when I look too closely at it. When I talk about the fields swishing through space, I have a terrible confusion between the symbols I use to describe the objects and the objects themselves. I cannot really make a picture that is even nearly like the true waves. So if you have some difficulty in making such a picture, you should not be worried that your difficulty is unusual.

(A more extended excerpt may be found in the Unit 4 Reader.)

We can summarize the general progression represented by the development of mechanics and electromagnetism by saying that physical theories have become increasingly abstract and mathematical. Newton banished the celestial machinery of early theories by substituting a mathematical theory using the laws of motion and the inverse-square law. Maxwell developed a mathematical theory of electromagnetism that, as Einstein showed, did not require any all-pervading material medium. We are seeing a growing disparity between common-sense ideas that develop from direct human experiences and the subtle mathematical abstractions developed to deal with effects that we cannot sense directly.

Yet these highly abstract theories do tell us about the things we can see and touch and feel. They have made it possible to devise the equipment that guides space probes to other planets and to design and operate the instruments that enable us to communicate with these probes. Not only are these theories at the base of all developments in electronics and optics, but they also contribute to our understanding of vision and the nervous system.

Maxwell's electromagnetic theory and the interpretation given to electromagnetism and mechanics by Einstein in the special theory of relativity produced a profound change in the basic philosophical viewpoint of the Newtonian cosmology. While we cannot yet give a comprehensive statement of these changes, some aspects of a new cosmology can already be detected. Before we can even hint at this new trend, we must give further attention to the behavior of matter and to the atomic theories developed to account for this behavior.

*"In the beginning everything was in confusion,  
then Mind came and reduced them to order."  
ANAXAGORAS, fifth century B.C.*

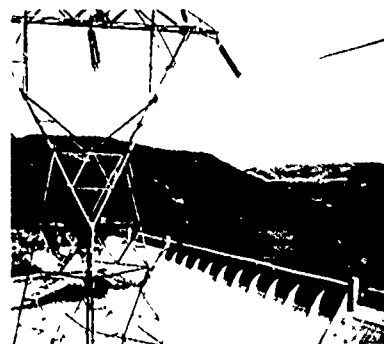
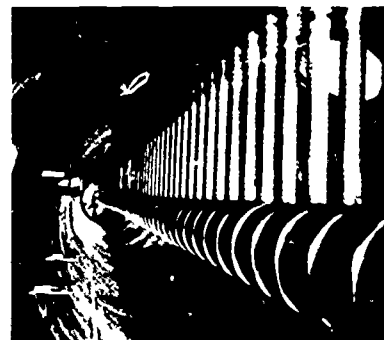
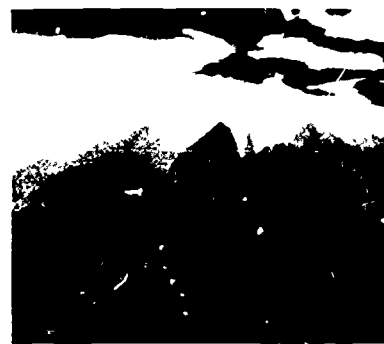

## Index

- Abrasives, 98  
Abstractions, 137  
Accelerating voltage, 123  
Action-at-a-distance, 1, 129  
Aethers, 129  
Air-gap, 117  
Albany, 79  
Alternating current, 85  
Aluminum, 98  
Amber, 35  
Ampere, 76, 78, 81, 108  
Ampere, unit, 43  
Analogy, 136  
Angelo, 136  
Antenna, 120  
Arc-lamp, 89  
Atmosphere, 22  
Aurora, 69  
Automation, 102
- Ball bearing, 110  
Bartholinus, Erasmus, 23  
Battery, 57, 60, 63  
Billion electron volt (Bev) 59  
Biophysical process, 5  
Biot, 76  
Blue sky, 21  
Bone, 123  
Boyle, Robert, 26  
Browne, Sir Thomas, 38  
Bright spot experiment, 15  
Brushes, 84  
Buffalo, 95
- Cambridge, 126  
Cambridge Philosophical Society, 108  
Camera obscura, 8  
Cancer, 123  
Carbonize, 92  
Carnot, 88  
Cataract Construction Co., 98, 99  
Cay, Charles, 115  
Charge, 40, 43, 49, 52, 54, 56, 109, 114  
Chemical energy, 57  
Cheshire cat, 133  
China, 35  
Circuits, 90  
Circular force, 77  
Civilization, 75, 102  
Coaxial cables, 121  
Coil of wire, 63  
Color, 17, 21; apparent, 19; TV tube 59  
Commonsense, 131, 137  
Communication, 100  
Commutator, 85  
Compass needle, 61  
Conduction current, 109  
Conductor, closed, 42  
Conservation of charge, 56  
Conversion of energy, 87  
Copper disc, 82  
Coulomb, Charles, 40, 58, 114  
    constant, 41  
    unit, 43  
Country life, 100  
Crystal planes, 123  
Current, 60, 78, 108
- Decentralization, 102  
De Magnete, 36  
Density, 112, 114  
Detector, 117  
Diffraction, 13, 15, 16, 23, 121  
Displacement current, 109, 111  
Distribution system, 90  
Double refraction, 23  
Double-slit, 13, 14  
Duhem, Pierre, 110  
Dynamo, 83, 87
- Edinburgh Academy, 126  
Edison Company, 95  
Edison, Thomas A., 89, 90, 98  
Effluvuim, 26, 36  
Einstein, 131  
Elasticity, 110  
Elastic propertus, 132  
Electric attraction, 39  
    charge, 120  
    currents, 56, 60, 75, 108  
    field, 42, 49, 58, 108, 111  
    furnace, 98  
    law of forces, 39  
    light bulb, 89  
    motor, 86  
    potential difference, 57, 58  
    power, 60  
    repulsion, 38  
    work, 60, 61  
Electrical units, summary, 65  
Electricity, relation to magnetism, 63  
    and society, 100  
Electrocution, 95  
Electromagnetic, induction, 79, 111  
    spectrum, 120  
    wave, 112, 114  
Electromagnetism, 75, 76, 136  
Electron, 52, 53  
Electron accelerator, 51  
Electron-volt (ev), 59  
Electrostatics, 56  
Electrostatic induction, 43, 44  
Elements, 78  
Emotional responses, 5  
Energy, 5, 57, 75, 123  
Ether, 26, 129-132  
Experiments, Hertz, 118  
Eye, 116, 120, 122
- Faraday, Michael, 2, 76, 81-84, 107, 108, 111, 126, 136  
Farmer, 102  
Federal Communications Commission (FCC) 121  
Feynman, Richard, 136  
Fields, 1, 3, 44, 45, 46, 48, 49, 64  
Filament, 89, 92  
Fizeau, 12, 13, 114  
Flashlight bulb, 60  
Force, 114  
    circular, 77  
    electrical, 39  
    "energy", 107  
    gravitational, 48  
    magnetic, 68  
Fossil fuel, 101  
Foucault, 12, 13  
Fourth power law, 22  
Franklin, Benjamin, 39, 40, 54, 56



Frequency, 5, 116, 120, 123  
 FM Broadcasting, 121  
 Fresnel, Augustin Jean, 14, 15, 26  
  
 Galilean relativity, 131  
 Galileo, 8  
 Gamma rays, 126  
 Gaulard and Gibbs, 94  
 General Electric, 95  
 Ghetto, 102  
 Gilbert, William, 36, 44  
 Goethe, 20  
 Gramme, Zenobi, 87  
 Graphite, 98  
 Gravitational field, 48  
   potential energy, 57, 58  
 Greek, 5, 35  
  
 Heat, 61, 90, 120  
 Helix, 78  
 Henry, Joseph, 79, 84, 94, 108  
 Herapath, William, 25  
 Hertz, Heinrich, 117, 118, 120  
 History, 128  
 Hooke, Robert, 19, 20, 23  
 Hull, 118  
 Huygens, 6, 9, 12, 23  
  
 Iceland spar, 23  
 Imagination, 136  
 Induction coil, 117, 118  
   electromagnetic, 79  
   electrostatic, 43  
 Influence, 45  
 Infrared radiation, 122  
 Insulator, 109  
 Intensity, 5  
 Interference, 13  
 Interferometer, 130  
 International Telecommunication Union (ITU),  
   121  
 Intuition, 78  
 Inverse-square law, 40  
 Iron ring, 81  
  
 Joule, 58, 59, 86  
 Jupiter, 9  
  
 Kelvin, 115  
 Kinetic energy, 58, 59  
 Kohlrausch, 115  
  
 Land, Edwin H., 25  
 Lebedev, 118  
 Leyden jar, 54, 56, 61  
 Light, 5; incandescent, 89; waves, 108  
 Lightning, 89  
 Lines of force, 63, 76, 81, 108, 119, 120  
 Lodestone, 35, 36, 37, 38  
 Longitudinal wave, 24  
 Loop of wire, 84  
 Lucretius, 36  
 Luminiferous ether, 2; media, 115  
  
 Magnet, 61; navigational use, 35; rotating, 77  
 Magnetic field, 44, 63, 64, 65, 109, 111, 112  
   force, 68  
   interaction, 55  
   pole, 77  
 Malus, Etienne, 24  
  
 Mass, 48  
 Mathematics, 78, 108, 137  
 Matter, 1  
 Maxwell, James Clerk, 2, 79, 108, 109, 111,  
   112, 117, 120, 128, 130, 136  
 Measurable aspects, 5  
 Mechanical model, 1, 110, 132, 136  
 Medium, 26  
 Melanin, 123  
 Metallic conductor, mirror, 118  
 Michelson, 130  
 Millikan, Robert A., 52  
 Model, 6, 12, 24, 111, 136  
 Momentum, 110  
 Morley, 130  
 Morse code, 121  
 Motor, electric, 86  
 Moving charge, 65  
  
 Newton, 2, 6, 12, 14, 17-20, 22, 26, 40, 75,  
   77, 137  
 Niagara Falls, 93, 95  
 Nichols, 118  
 Northern lights, 69  
 North-seeking pole, 63  
 Nuclei, 126  
  
 Observers, 131  
 Oersted, Hans Christian, 62, 63, 65, 75, 76,  
   81, 107, 108  
 Ohm's law, 60  
 Oil drop, 52  
 Orbit, 130  
 Ozone, 123  
  
 Parallel circuit, 90  
 Particle, 6, 11, 136  
 Path, 58, 68, 69  
 Pattern, 14  
 Peak load 98, sensitivity, 122  
 Philosophical toy, 87  
 Photochemical, 123  
 Photographic plate, 123  
 Photosynthesis, 5  
 Physical labor, 100  
 Pigment, 17, 123  
 Pixii, Hippolyte, 85  
 Point sources, 8  
 Poisson, Simon, 14, 15  
 Polarization, 23, 25, 107, 110  
 Polarizer, 25  
 Polaroid, 25  
 Poles, 38, 77  
 Potential difference, 57, 60  
 Power, 12, 60, 87, 92, 93  
 Pressure, 118  
 Priestley, 40  
 Primary coil, 94  
 Princeton, 79  
 Prism, 18  
 Propagation, 6, 112  
 Psychological aspects, 5  
  
 Quantum theory, 128  
  
 Radar, 121  
 Radiation belts, 69  
 Radio, 101, 120, 121  
 Rainbow, 20  
 Ray, 8, 12; Gamma, 126

Reflection, 11, 12  
 Refraction, 11, 12; double, 23  
 Relativity, 115, 128, 131, 137  
 Resistance, 60  
 Römer, Ole, 9  
 Rotating magnet, 77  
 Royal Institution, 107  
 Rural electrification, 100  
  
 Satellites, 121  
 Savart, 76  
 Scattering, 22, 23  
 Schelling, Friedrich, 20, 107  
 Science, 88  
 Scoresby, 86  
 Seebeck, 76  
 Series circuit, 90  
 Servants, 101  
 Shadow, 8  
 Silicon, 98  
 Sky, blue, 21, 22  
 Social effects, 89, 100  
 Soot, 75  
 Sound, 9  
 Source, 45  
 Southern lights, 69  
 Space, 109, 112, 131  
 Spark, 117  
 Spectrum, 17, 21  
 Speech, 121  
 Speed, 10, 12, 20, 112, 114, 120, 131  
 Sprengel, Hermann, 89  
 Stability, 126  
 Steam engine, 75  
 Stiffness, 112, 114  
 Sulphate of iodo-quinine, 24  
 Synthesis, 115  
  
 Technology, 88  
 Telegraph, 101  
 Telephone, 100  
 Telescope, 17  
 Television, 59, 121  
 Tennessee Valley Authority, 100  
 Terrella, 38  
 Thomson, William, 2  
 Time, 61, 112, 131  
 Time chart, 113  
 Torsion balance, 40  
 Toy, philosophical, 87  
 Transformer, 94  
 Transmission, 87  
 Transverse undulations, 115  
  
 Ultraviolet, 120, 123  
  
 Vacuum pump, 89  
 Van Allen, 69  
 Van Musschenbroek, Pieter, 54  
 Vienna Exhibition, 87  
 Viscosity, 128  
 Visible light, 122  
 Vision, 5  
 Volt, 58  
 Volta, Alessandro, 56, 75  
 Voltage, 57, 93, 123  
 Voltaic cell, 83  
 Von Guericke, Otto, 54  
 Vortices, 132  
  
 Watt, unit, 61  
 Wave, 6, 12, 24, 25, 136  
 Wavelengths, 5, 21, 121, 122  
 Weber, 115  
 Westinghouse, 94, 95  
 Wheatstone, Sir Charles, 107  
 Whirling parts, 115  
 White light, 17, 18  
 Wollaston, 76  
  
 X-rays, 120, 123, 126  
  
 Young, 13, 14, 23, 26

**Brief Answers to Unit 4 Study Guide**

**Chapter 13**

- 13.1 7.5 cm
- 13.2 (a) distance too small  
(b) no  
(c) large distances involved  
(d) lower limit was achieved
- 13.3 (a)  $4.4 \times 10^9$  m  
(b)  $3.0 \times 10^8$  m/sec  
(c) conjunction cycle
- 13.4  $9.5 \times 10^{15}$  m
- 13.5 4.3 yrs.; 28 times
- 13.6 path shown
- 13.7 36"
- 13.8 invisible
- 13.9 diagrams
- 13.10 (a) diagram  
(b) inverse with height
- 13.11 (a) diagram  
(b)  $\frac{1}{2}mv^2$ ;  $m\vec{v}_x = m\vec{v} \sin \theta$ ;  
 $m\vec{v}_y = m\vec{v} \cos \theta$   
(c)  $\frac{1}{2}mv^2$  and  $m\vec{v}_x$   
(d) energy conservation  
(e)  $m\vec{u}_x = m\vec{u} \sin \theta_r$ ;  $m\vec{u}_y = m\vec{u} \cos \theta_r$   
(f) derivation
- 13.12 diagrams
- 13.13 (a)  $(m + \frac{1}{2})\lambda$   
(b) red  
(c) increased fringe separation  
(d) same as (c)  
(e) same separation
- 13.14 appears in bright fringes
- 13.15 constructive interference
- 13.16  $6 \times 10^{14}$  cps;  $10^{10}$  times AM
- 13.17 (a) no  
(b) discussion
- 13.18 discussion
- 13.19 discussion

**Chapter 14**

- 14.1 (a) tripled  
(b) halved  
(c) not changed
- 14.2 95 km
- 14.3 discussion
- 14.4 yes; positive
- 14.5 (a) 1.6 N/kg  
(b)  $4.1 \times 10^9$  N/kg  
(c)  $g_r \propto r$

- 14.6 reaction to field, then to source
- 14.7 (a) right  
(b) down
- 14.8 (a)  $10^6$  coulombs  
(b)  $10^{-9}$  coulombs/m<sup>2</sup>
- 14.9 sketch (normal to surfaces)
- 14.10 help
- 14.11  $6.25 \times 10^{18}$  electrons
- 14.12  $3.4 \times 10^{42}$
- 14.13 (a)  $\frac{1}{2}mv^2 = \frac{1}{2}kq^2/R$   
(b)  $1.2 \times 10^{-18}$ J  
(c)  $1.5 \times 10^6$  m/sec
- 14.14 conductor
- 14.15 30 volts
- 14.16 zero
- 14.17 derivation
- 14.18 (a)  $3 \times 10^6$  volt/meter  
(b)  $10^7$  volt/meter
- 14.19 (a) 12 volts  
(b) zero  
(c) 12 volts
- 14.20 (a) 100 eV or  $1.6 \times 10^{-17}$ J  
(b)  $5.6 \times 10^6$  m/sec
- 14.21 (a) 4 amps  
(b) 5 ohms  
(c) 15 volts
- 14.22 (a)  $10^7$  volts  
(b)  $5 \times 10^8$  joules
- 14.23 discussion
- 14.24 20 watts
- 14.25 (a) 8 watts  
(b) 20 watts  
(c) 45 watts
- 14.26 compass can't respond
- 14.27 north
- 14.28 3 amps north
- 14.29 (a) derivation  
(b) v, B and R
- 14.30 derivation
- 14.31 (a) derivation  
(b) discussion
- 14.32 west

**Chapter 15**

- 15.1 discussion
- 15.2 yes
- 15.3 all except (d)
- 15.4 discussion
- 15.5 (a) exercise  
(b) upward  
(c) downward

- 15.6 Lenz's law
- 15.7 outside magnet
- 15.8 opposite
- 15.9 discussion
- 15.10 (a) 1 amp  
(b) 10 ohms  
(c) burn out
- 15.11 (a) 1/12 amp  
(b) 1440 ohms
- 15.12 (a) 1 amp,  $\frac{1}{2}$  amp  
(b) 1/5 watt, 1/20 watt  
(c) 0.97 amp, 0.19w, 5.6w;  
0.50 amp, 0.05w, 6w.
- 15.13 5 amps
- 15.14 derivation
- 15.15 low voltage coil
- 15.16 discussion
- 15.17 discussion
- 15.18 report
- 15.19 discussion
- 15.20 sketch
- 16.23 discussion
- 16.24 discussion
- 16.25 unnecessary for mathematical description
- 16.26 discussion
- 16.27 discussion
- 16.28 body: mechanical models  
grin: mathematical description

## Chapter 16

- 16.1 symmetry
- 16.2 no
- 16.3 accelerating charge, mutual induction
- 16.4 (a) height  
(b) pressure  
(c) field strength
- 16.5 measurement uncertainty
- 16.6 detector orientation
- 16.7 light properties
- 16.8 discussion
- 16.9 absorption effects, etc.
- 16.10  $5 \times 10^6$  m
- 16.11 10 m to  $10^2$  m
- 16.12 frequency modulated
- 16.13 discussion
- 16.14 discussion
- 16.15 ionospheric reflection of shorter wavelength radiation
- 16.16 27,900 miles
- 16.17 phase difference between direct and reflected waves
- 16.18 AM; FM
- 16.19 2.6 sec.
- 16.20 absorption
- 16.21 evolution
- 16.22 UV and IR

## Picture Credits

Cover photograph: from the book story of Electricity by Edward Tatnall Dyer Coker by Eric Nitsche Int'l. Published by Hawthorn Books, Inc., 70 Fifth Avenue, New York, New York

### Prologue

(Facing page 1) (top) Euler, Leonhard, Theoria Motuum Planetarum et Cometarum, Berlin, 1744; (bottom left) Descartes, René, Principia Philosophiae, 1664; (middle right) Maxwell, James Clerk, A Treatise on Electricity and Magnetism, vol. II, Oxford Press, 1892.

P. 3 National Radio Astronomy Observatory, Greenbank, West Virginia.

### Chapter 13

Pp. 4, 5 "Grand Tetons & Snake River." Minor White.

P. 7 (Delphi) Greek National Tourist Office; (plane) American Airlines; (light through prism) Bausch & Lomb Optical Co.

P. 8 (camera obscura) Frisius, Reiner Gemma, De Radio Astronomico et Geometrico Liber, 1545.

Pp. 10, 11 Bausch & Lomb Optical Co.

P. 13 (portrait) Engraved by G. R. Ward, from a picture by Sir Thomas Lawrence.

P. 15 (portrait) Cabinet des Estampes Bibliothèque Nationale, Paris.

Pp. 15, 16 (diffraction patterns) Cagnet, Francon & Thrierr, Atlas of Optical Phenomena, c 1962, Springer-Verlag OHG, Berlin.

P. 16 (radio telescope) National Radio Astronomy Observatory, Greenbank, West Virginia.

P. 27 Courtesy of the Fogg Art Museum. Harvard University. Grenville L. Winthrop bequest.

P. 33 Reprinted by permission from F. W. Sears, Optics, 3rd Ed., 1949, Addison-Wesley, Reading, Mass.

### Chapter 14

P. 34 Courtesy of the Lawrence Radiation Laboratory, University of California, Berkeley.

P. 39 from a painting by Mason Chamberlain in 1762, engraved by C. Turner. Courtesy of Burndy Library.

P. 41 (portrait) Musée de Versailles; (drawing) from Coulomb's mémoire to the French Academy of Sciences, 1785.

Pp. 50, 51 (all photographs) Courtesy of Mr. Harold M. Waage, Palmer Physical Laboratory, Princeton University.

P. 55 (top) The van Marum electrical machine, 1784. Courtesy of the Burndy Library; (bottom right) Watson, William, Sequel to the Experiments and Observations Tending to Illustrate the Nature and Properties of Electricity, London, 1746; (bottom left) Histoire de l'Académie Royale des Sciences, Paris, 1746.

P. 56 (portrait) The Science Museum London; (Franklin's drawing) American Academy of Arts and Sciences.

P. 59 (right) Courtesy of B. Freudenberg, Inc., N.Y.C.; (left) Brookhaven National Laboratory.

P. 62 (portrait) Nationalhistoriske Museum, Frederiksborg; (bottom left) from PSSC Physics, D. C. Heath and Company, Boston, 1965.

P. 64 (portrait) Bibliothèque de l'Académie des Sciences; (model) Crown copyright. Science Museum, London.

P. 66 (two field photos center) from Photographs of Physical Phenomena, c Kodansha, Tokyo, 1968; (bottom) General Electric Research and Development Center, Schenectady, New York.

P. 67 (left, top to bottom) Magnion, Inc., Burlington, Mass; Science Museum, London; General Electric Research & Development Center; (right) U. S. Steel Corp., Boston.

P. 69 Dr. V. P. Hessler.

P. 72 Radio Corporation of America

P. 73 c 1966 by The New York Times Company. Reprinted by permission.

### Chapter 15

P. 74 Freelance Photographs Guild, New York.

P. 77 Deutsches Museum, Munich.

P. 78 (field photo) from Photographs of Physical Phenomena, © Kodansha, Tokyo, 1968.

P. 80 (portrait) The Royal Institution of Great Britain; (drawing) The Royal Institution of Great Britain.

P. 86 (Henry's electromagnetic motor) Alglave, Emile and Boulard, J., La Lumière Electrique, Paris, 1882.

P. 88 (coils) Consolidated Edison Company of New York, Inc.; (generators) Tennessee Valley Authority.

P. 89 (top and bottom) Figuier, Louis, Les Nouvelles Conquêtes de la Science, Paris, 1884.

P. 90 (patent) U. S. Patent Office Picture Collection.

P. 91 (portraits) Thomas Alva Edison Foundation.

P. 96 (left top) Westinghouse Electric Corp., (left bottom) Edison Electric Institute, N.Y.C.

P. 97 (power grid) Edison Electric Institute; (N.Y.C. at night) Con Edison of New York; (N.Y.C. blackout) Bob Gomel, LIFE MAGAZINE, c Time Inc.

P. 99 (right) Tennessee Valley Authority; (left) Power Authority of the State of New York.

P. 103 Power Authority of the State of New York.

### Chapter 16

P. 106 Dr. V. P. Hessler.

P. 118 American Institute of Physics.

P. 122 Courtesy of Eastman Kodak Company.

P. 123 General Electric Company, X-Ray Department.

P. 124 (top left) McMath-Hulbert Observatory of University of Michigan; (top right) Harvard College Observatory; (bottom left) Sacramento Peak Observatory, Air Force Cambridge Research Laboratory. Photo courtesy of American Science and Engineering, Inc.; (bottom right) American Science and Engineering, Inc.; (center) Ball Brothers Research Corp., Boulder, Colorado.

P. 125 (top left) U. S. Air Force Photo. Courtesy of News Photo Branch, Defense Information Service; (bottom left) American Science and Engineering, Inc.; (right, top to bottom) M.I.T. Lincoln Laboratory; *ibid*; M.I.T. Lincoln Laboratory by D. Downes, A. Maxwell and M. L. Meeks; from *Science Year, The World Book Science Annual*. c 1967 Field Enterprises Educational Corporation, Chicago.

P. 126 Brookhaven National Laboratory.

P. 127 (manuscript) Royal Society of Edinburgh, Scotland; (portrait) Trinity College Library, Cambridge, England.

Pp. 132, 133 John Tenniel drawings.

All photographs not credited above were made by the staff of Harvard Project Physics.

#### Acknowledgments

##### Prologue

P. 2 Newton, Sir Isaac.

##### Chapter Thirteen

P. 5 Blackmore, Richard, *Creation, A Philosophical Poem*, Robert Johnson, p. 91.

P. 9 Mallett, David, *The Excursion*, J. Walthoe, p. 57.

P. 14 Young, Thomas, *Course of Lectures on Natural Philosophy and the Mechanical Arts*, Cox.

Pp. 17-19 Newton, Sir Isaac, "A New Theory About Light and Colors," *Philosophical Transactions, The Royal Society of London*, Lowthrop edition, Vol. 1, pp. 679-686.

P. 20 Thomson, James, *The Poetical Works of James Thomson*, William Tegg and Co., pp. 145-46 and p. 10.

P. 21 Goethe, J.W., *Goethe As A Scientist*, Magnus, Rudolf, Henry Schuman, pp. 184-85.

P. 23 Van Gogh, Vincent, *The Letters of Vincent Van Gogh*, Vol. 3, The New York Graphic Society, p. 42.

P. 24 Newton, Sir Isaac, *Optics*, Dover Publications, p. 363.

P. 26 Young, Thomas, *Miscellaneous Works* (London, 1855) Vol. 1, p. 415.

P. 27 Glover, Richard, "A Poem on Newton," *A View of Sir Isaac Newton's Philosophy*, S. Palmer, p. 15.

P. 28 Galilei, Galileo, *Dialogues Concerning Two New Sciences*. trans. Crew, H. and de Salvio, A., Dover Publications, pp. 42-43.

P. 32 Savage, Richard, "The Wanderer," *The Poetical Works of Richard Savage*. ed. Tracy, Clarence, Cambridge University Press, pp. 147-48.

##### Chapter Fourteen

Pp. 36-38 Gilbert, William, *De Magnete*, trans. Mottelay, P. Fleury, Dover Publications, pp. 1-14 and p. 121.

P. 54 von Guericke, Otto.

Pp. 56-57 Volta, Alessandro, *Philosophical Transactions*, 1300.

P. 64 Ampère, André-Marie

##### Chapter Fifteen

P. 80 Faraday, Michael

P. 82 Faraday, Michael, *Faraday's Diary*.

P. 86 Henry, Joseph, *Silliman's American Journal of Science*, Vol. XX, p. 340.

P. 86 Hunt, Robert, "On the Application of Electro-Magnetism as a Motive Power," *Philosophical Magazine*, Vol. 36, Taylor and Francis, pp. 550-52.

Much of the historical information in Chapter 15, in particular the discussion of the ac-dc controversy, is based on the book by Harold I. Sharlin, *The Making of the Electrical Age* (Abelard-Schuman, New York, 1963). We are grateful to Professor Sharlin for giving his permission to use this material.

##### Chapter Sixteen

P. 108 Maxwell, Sir James Clerk, "On Faraday's Lines of Force," *Transactions of the Cambridge Philosophical Society*.

P. 110 Maxwell, Sir James Clerk.

P. 115 Maxwell, Sir James Clerk, *The Scientific Papers of James Clerk Maxwell*, ed., Niven, W. D., Cambridge University Press, Vol. 1, p. 500.

P. 115 Maxwell, Sir James Clerk, *Life of James Clerk Maxwell*, Campbell, L., and Garnett, W., MacMillan & Co., p. 342 and p. 257.

P. 128 Maxwell, Sir James Clerk.

P. 128 Maxwell, Sir James Clerk, *Electricity and Magnetism*, Vol. 1, Clarendon Press, pp. xiii-xiv, not inclusive.

P. 128 Maxwell, Sir James Clerk.

P. 129 Maxwell, Sir James Clerk, *The Scientific Papers of James Clerk Maxwell*, ed., Niven, W. D., Vol. II, Cambridge University Press, p. 775.

P. 129 Maxwell, Sir James Clerk.

Pp. 132-33 Carroll, Lewis, *The Complete Works of Lewis Carroll*, Random House, pp. 66-67, not inclusive.

##### Epilogue

Pp. 136-37 Feynman, R. P., *The Feynman Lectures on Physics*, Feynman, R. P., Leighton, R. B., and Sands, M., Vol. 2, Addison-Wesley, pp. 9-10.



## Answers to End of Section Questions

### Chapter 13

- Q1 Diffraction effects become greater as a slit is made increasingly narrow, spreading the light into a diverging beam.
- Q2 Römer based his prediction on the extra time he had calculated it would require light to cross the orbit of the earth.
- Q3 Römer had shown that light does have a finite speed.
- Q4 Experiments carried out by Foucault and Fizeau showed that light has a lower speed in water than in air, whereas the particle model required that light have a higher speed in water.
- Q5 When light enters a more dense medium, its wavelength and speed decrease, but its frequency remains unchanged.
- Q6 Young's experiments showed that light could be made to form an interference pattern, and such a pattern could be explained only by assuming a wave model for light.
- Q7 It was diffraction that spread out the light beyond the two pinholes so that overlapping occurred and interference took place between the two beams.
- Q8 Poisson applied Fresnel's wave equations to the shadow of a circular obstacle and found that there should be a bright spot in the center of the shadow.
- Q9 Newton passed a beam of white light through a prism and found that the white light was somehow replaced by a diverging beam of colored light. Further experiments proved that the colors could be recombined to form white light.
- Q10 Newton cut a hole in the screen on which the spectrum was projected and allowed a single color to pass through the hole and hence through a second prism: he found that the light was again refracted but no further separation took place.
- Q11 A coat appears yellow if it reflects mainly yellow light and absorbs other colors of light.
- Q12 The "nature philosophers" were searching for unifying principles and were very unhappy with the idea that something they had regarded as unquestionably pure had many components.
- Q13 The amount of scattering of light by tiny obstacles is greater for shorter wavelengths than for longer wavelengths.
- Q14 The "sky" is sunlight scattered by the atmosphere. Light of short wavelength, the blue end of the spectrum, is scattered most.
- Q15 Hooke and Huygens had proposed that light waves are similar to sound waves: Newton objected to this view because the familiar straight-line propagation of light was so different from the behavior of sound. In addition, Newton realized that polarization phenomena could not be accounted for in terms of spherical pressure waves.
- Q16 "Unpolarized" light is a mixture of waves polarized in various directions.
- Q17 Light had been shown to have wave properties, and all other known wave motions required a physical medium to transmit them, so it was assumed that an "ether" must exist to transmit light waves.
- Q18 Because light is a transverse wave and propagates at such a high speed, the ether must be a very stiff solid.

### Chapter 14

- Q1 He showed that the earth and the lodestone affect a magnetized needle in similar ways.
- Q2 Amber attracts many substances; lodestone only a few. Amber needs to be rubbed to attract; lodestone always attracts. Amber attracts towards its center; lodestone attracts towards either of its poles.
- Q3 A cork hung inside a charged silver can was not attracted to the sides of the can. (This implied that there was no net electric force on the cork—a result similar to that proved by Newton for gravitational force inside a hollow sphere.)
- Q4  $F_{e1} \propto 1/R^2$  and  $F_{e1} \propto q_A q_B$
- Q5  $F_{e1}$  will be one quarter as large.
- Q6 No, the ampere is the unit of current.
- Q7 No, induced charges could account for this behavior.
- Q8 Each point in a scalar field is given by a number only, whereas each point in a vector field is represented by a number and a direction.
- Q9 a) the same direction as the gravitational force on a test mass placed at that point  
b) the same direction as the electric force on a positive test charge at that point.
- Q10 The corresponding forces would also be doubled and therefore the ratios of force to mass, and force to charge, would be unchanged.
- Q11 If the droplets or spheres are charged negatively, they will experience an electric force in the direction opposite to the field direction.



- Q12 Charge comes in basic units: the charge of the electron.
- Q13 Franklin observed that unlike charges can cancel each other and he therefore proposed that negative charges are simply a deficiency of positive charges.
- Q14 It produced a steady current for a long period of time.
- Q15 The voltage between two points is the work done in moving a charge from one point to the other, divided by the magnitude of the charge.
- Q16 No; the potential difference is independent of both the path taken and the magnitude of the charge moved.
- Q17 An electron-volt is a unit of energy.
- Q18 If the voltage is doubled the current is also doubled.
- Q19 The electrical energy is changed into heat energy and possibly light energy. (If the current is changing, additional energy transformations occur; this topic will be discussed in Chapter 16.)
- Q20 Doubling the current results in four times the heat production (assuming the resistance is constant).
- Q21 The charges must be moving relative to the magnet. (They must in fact be moving across the field of the magnet.)
- Q22 It was found to be a "sideways" force!
- Q23 Forces act on a magnetized (but uncharged) compass needle placed near the current.
- Q24 Ampère suspected that two currents should exert forces on each other.
- Q25 b), c), d).
- Q26 b), c), e).
- Q27 The magnetic force is not in the direction of motion of the particle—it is directed off to the side, at an angle of  $90^\circ$  to the direction of motion.
- Chapter 15**
- Q1 The single magnetic pole is free to move and it follows a circular line of magnetic force around the current carrying wire.
- Q2 electric currents circulating within the magnets
- Q3 electromagnetic induction
- Q4 the production of a current by magnetism
- Q5 The first current must be changing.
- Q6 the Faraday disc dynamo
- Q7 The loop is horizontal for maximum current, vertical for minimum.
- Q8 It reverses the connection of the generator to the outside circuit at every half turn of the loop.
- Q9 Use a battery to drive current through the coil.
- Q10 Batteries were weak and expensive.
- Q11 An unknown workman showed that Gramme's dynamo could run as a motor.
- Q12 too glaring, too expensive, too inconvenient
- Q13 an improved vacuum pump
- Q14 A small current will have a large heating effect if the resistance is high enough.
- Q15 There is less heating loss in the transmission wires.
- Q16 A current is induced in the secondary coil only when there is a changing current in the primary coil.
- Chapter 16**
- Q1 a magnetic field
- Q2 the small displacement of charges that accompanies a changing electric field
- Q3 the relations between electric and magnetic fields
- Q4 the ratio of the values of a quantity of charge measured electrically and magnetically
- Q5 The speed of electromagnetic waves turned out to be, within the limits of experimental error, the same as the speed of light.
- Q6 the existence of electromagnetic waves
- Q7 a loop of wire
- Q8 Electromagnetic waves exert pressure on any surface that reflects or absorbs them.
- Q9 They have very great wavelengths (from tens to thousands of meters).
- Q10 The signals travel in nearly straight lines and would otherwise pass into space instead of following the earth's curvature.
- Q11 The higher the frequency, the greater is their penetration of matter.
- Q12  $10^5$  times larger

- Q13 X rays are produced by the sudden deflection or stopping of electrons; gamma radiation is emitted by unstable nuclei of radioactive materials.
- Q14 He held that knowledge is more enduring if achieved in more than one way.
- Q15 experiments and procedures that have failed, as well as those that were successful
- Q16 It was almost unthinkable that there could be waves without a medium to transmit them.
- Q17 Albert Einstein's (in his theory of relativity)