

ANALYSIS OF CHANGES – 2014 NEC



Training Presentation by:  
International Association of Electrical Inspectors

---

---

---

---

---

---

---

---

---

---

Analysis of Changes-2014 NEC



---

---

---

---

---

---

---

---

---

---

Code-Wide Changes: (4) New Articles



Article 393 Low Voltage Suspended Ceiling Power Distribution Systems



Article 646 Modular Data Centers



Article 728 Fire-Resistive Cable Systems



Article 750 Energy Management Systems

Copyright © IAETI 2014

---

---

---

---

---

---

---

---

---

---

### 110.21(B) Field-Applied Hazard Markings

- DANGER indicates a hazardous situation which, if not avoided, will result in death or serious injury



- WARNING indicates a hazardous situation which, if not avoided, could result in death or serious injury



- CAUTION indicates a hazardous situation which, if not avoided, may result in minor or moderate injury



Copyright © JAEI 2014

---

---

---

---

---

---

---

---

### 110.21(B) Field-Applied Hazard Markings

Hazard markings, signs or labels should meet the requirements in ANSI Z535.4 for suitable font sizes, words, colors, symbols and location requirements for labels



Copyright © JAEI 2014

---

---

---

---

---

---

---

---

### 110.25 Lockable Disconnecting Means

- New 110.25 added to provide consistent requirements at one location for **“Lockable Disconnecting Means”** rules
- Requirements for a disconnecting means to be “lockable in the open position” existed in a number of locations in the 2011 *NEC*
- Forty-six (46) companion proposals to move lockable disconnect requirements to new 110.25
- New provision intended to facilitate a lockout/tagout situation
- New exception added where the attachment plug serves as the disconnecting means

Copyright © JAEI 2014

---

---

---

---

---

---

---

---

### 110.25 Lockable Disconnecting Means (cont.)

- **110.25 Lockable Disconnecting Means.** Where a disconnecting means is required to be lockable open, elsewhere in this Code, it shall be capable of being locked in the open position. The provisions for locking shall remain in place with or without the lock installed.
- **Exception:** Cord-and-plug connection locking provision shall not be required to remain in place without the lock installed.

Copyright © JAEI 2014

---

---

---

---

---

---

---

---

---

---

---

---



---

---

---

---

---

---

---

---

---

---

---

---

### 110.26(C)(3) Personnel Doors

- The ampere value related to provisions for "Personnel Doors" for "Entrance to and Egress from Working Space" was lowered to **800 amperes** from 1200 amperes
- The term "**listed panic hardware**" replaces the previous list of specific hardware provided at this requirement
- Serious injury and fatalities have occurred involving electrical equipment rated at below 1200 amperes
- This same panic hardware change occurred at **110.33(A)(3)** for equipment with a voltage rating over 600 volts

Copyright © JAEI 2014

---

---

---

---

---

---

---

---

---

---

---

---

### 110.26(C)(3) Personnel Doors

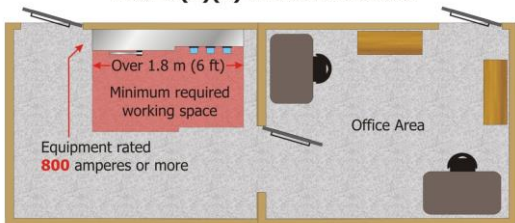

**110.26(C)(3) Personnel Doors.** Where equipment rated 800 A or more that contains overcurrent devices, switching devices, or control devices is installed and there is a personnel door(s) intended for entrance to and egress from the working space less than 7.6 m (25 ft) from the nearest edge of the working space, the door(s) shall open in the direction of egress and be equipped with listed panic hardware.

**Note:** Requirements for "Large Equipment" at 110.26(C)(2) still applies to equipment rated at 1200 A or more and over 1.8 m (6 ft) wide.

Copyright © IAEEI 2014

---

---

---

---

---

---

---

---

---

---

### 110.26(E)(2) Dedicated Equipment Space

- "Dedicated Equipment Space" added for equipment located outdoors
- Dedicated equipment space now required for outdoor installations as well as indoor installations
- Dedicated equipment space equal to the width and depth of the equipment and extending from grade to a height of 1.8 m (6 ft) above the equipment
- Same "equipment foreign to the electrical installation" is often present such as gas piping, water piping, mechanical refrigeration lines, irrigation equipment, phone and internet equipment, compressed air lines, and other non-electrical equipment

Copyright © IAEEI 2014

---

---

---

---

---

---

---

---

---

---



---

---

---

---

---

---

---

---

---

---



---

---

---

---

---

---

---

---



---

---

---

---

---

---

---

---

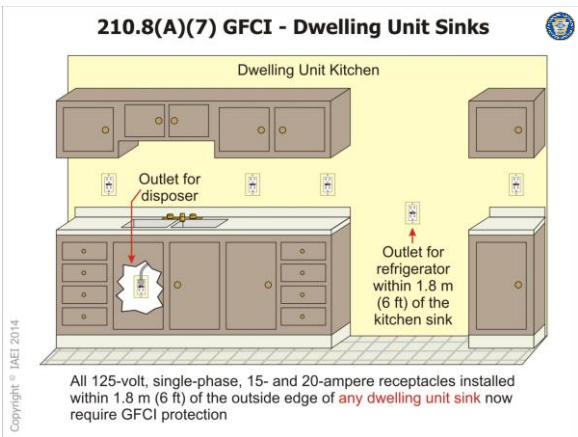

---

---

---

---

---

---

---

---



---

---

---

---

---

---

---

---



---

---

---

---

---

---

---

---

### 210.8(A)(9) Dwelling Unit Bathtubs or Shower Stalls

- GFCI protection now required where receptacles are installed within 1.8 m (6 ft) of the outside edge of dwelling unit **"Bathtubs or Shower Stalls"**
- Bathtubs or shower stalls are not always located in an area that meets the Article 100 definition of a "bathroom"
- Bathroom is "an area including a basin with one or more of the following: a toilet, a urinal, a tub, a shower, a bidet, or similar plumbing fixtures"
- Example: a room or area connected to a dwelling unit bedroom with a bathtub or shower stall as the only plumbing fixture in that particular room or area with a basin sink and toilet provided in another common area of the dwelling

Copyright © JAEI 2014

---

---

---

---

---

---

---

---

### 210.8(A)(9) GFCI: Bathtubs or Shower Stalls

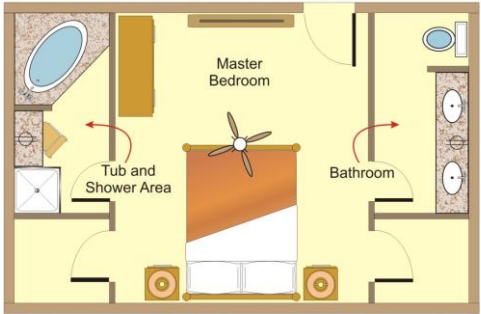

All 125-volt, single-phase, 15- and 20-ampere receptacles installed within 1.8 m (6 ft) of the outside edge of a dwelling unit bathtub or shower stall requires GFCI protection

Copyright © IAEEI 2014

---

---

---

---

---

---

---

---

### 210.8(A)(10) GFCI: Laundry Areas

- All dwelling unit "Laundry Areas" now require GFCI protection for 125-volt, single phase, 15-and 20-ampere receptacles (*regardless of presence of a sink or distance from same*)
- A laundry room sink is no longer the driving factor whether GFCI protection is required or not
- GFCI protection in laundry areas addresses increased shock hazard risk and is consistent with other NEC requirements for GFCI protection of receptacles in areas in close proximity of water
- Increased usage of GFCI protection for personnel at receptacles of residential homes is a highly effective means of further reducing the potential for electrical shock hazards

Copyright © IAEEI 2014

---

---

---

---

---

---

---

---



---

---

---

---

---

---

---

---



---

---

---

---

---

---

---

---

**210.8(B)(8) GFCI: Garages, Service Bays, and Similar Areas**

- GFCI protection required for all 125-volt, single-phase, 15- and 20-ampere receptacles installed in all non-dwelling unit **garages, service bays, and similar areas** (other than vehicle exhibition halls and showrooms)
- The phrase, "where electrical diagnostic equipment, electrical hand tools, or portable lighting equipment are to be used" was deleted
- Many commercial garages have receptacles installed for purposes other-than the use of hand tools such as electric engine block heaters or battery charging equipment
- Does not apply to such things as auto, power equipment (lawn mowers), or recreational vehicle dealership showrooms

Copyright © IAEI 2014

---

---

---

---

---

---

---

---



---

---

---

---

---

---

---

---





---

---

---

---

---

---

---

---



---

---

---

---

---

---

---

---

**210.8(D) Dwelling Unit Kitchen  
Dishwasher Branch Circuit**

- GFCI protection now required for all outlets that supply **dishwashers** installed in dwelling units
  - Includes both receptacle and hard-wired outlet for dishwasher
- Modern-day electronically controlled dishwashers can experience “end of life” failures that can result in increased risk of electrical shock
- GFCI protection for outlets supplying dishwashers can mitigate these increased risk of electrical shock

Copyright © JAEI 2014

---

---

---

---

---

---

---

---



---

---

---

---

---

---

---

---

### 210.12 Arc-Fault Circuit-Interrupters



AFCI devices required to be installed in a readily accessible location

Copyright © IAEEI 2014

---

---

---

---

---

---

---

---

### 210.12(A) AFCI Protection

- "Kitchens" and "laundry areas" were added to list of areas requiring AFCI protection
- This expansion into the kitchens and laundry areas is another step in the incremental approach for AFCI protection at dwelling units
- AFCI protection was also expanded to include 15 or 20 ampere branch circuits supplying outlets or "devices" which would now include switches, etc.
- AFCI protection is now required to be installed in dwelling unit **kitchens**, family rooms, dining rooms, living rooms, parlors, libraries, dens, bedrooms, sunrooms, recreation rooms, closets, hallways, **laundry areas**, or similar rooms or areas

Copyright © IAEEI 2014

---

---

---

---

---

---

---

---



---

---

---

---

---

---

---

---

### 210.12(A)(1) – (6) AFCI Protection

- AFCI protection methods were expanded and language put into a **list format**
- Provisions for outlet branch circuit (OBC) AFCI devices were expanded
- The first two previous exceptions were revised to positive language and put into a **list format of six provisions** for providing AFCI protection
- AFCI protection for dwelling units has taken another step forward with the continued incrementally approach to the expansion of this safety enhancing protection

---

---

---

---

---

---

---

---

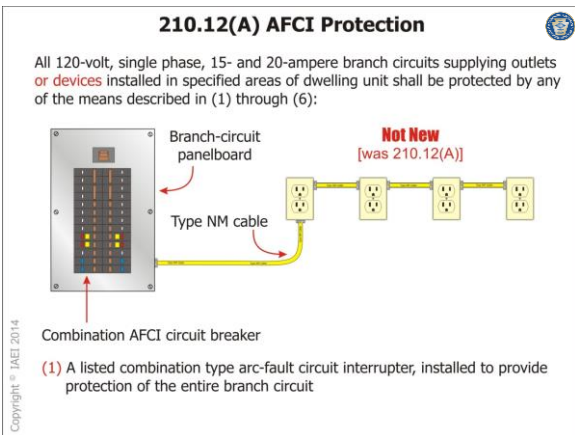

---

---

---

---

---

---

---

---

### 210.12(A) AFCI Protection

All 120-volt, single phase, 15- and 20-ampere branch circuits supplying outlets or devices installed in specified areas of dwelling unit shall be protected by any of the means described in (1) through (6):

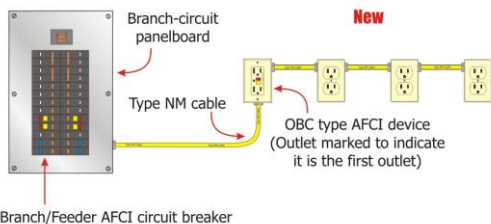

- (2) A listed branch/feeder type AFCI installed at the origin of the branch circuit in combination with a listed outlet branch circuit type AFCI installed at the first outlet box on the branch circuit (first outlet marked to indicate that it is the first outlet)

---

---

---

---

---

---

---

---

---

---

### 210.12(A) AFCI Protection

All 120-volt, single phase, 15- and 20-ampere branch circuits supplying outlets or devices installed in specified areas of dwelling unit shall be protected by any of the means described in (1) through (6):

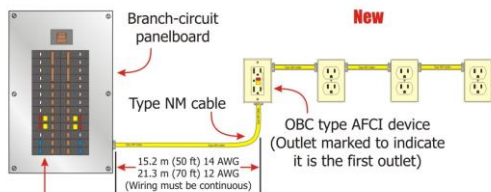

- (3) A listed supplemental arc protection circuit breaker installed at the origin of the branch circuit in combination with a listed outlet branch circuit type AFCI installed at the first outlet box on the branch circuit (with three limiting conditions)

---

---

---

---

---

---

---

---

---

---

### 210.12(A) AFCI Protection

All 120-volt, single phase, 15- and 20-ampere branch circuits supplying outlets or devices installed in specified areas of dwelling unit shall be protected by any of the means described in (1) through (6):

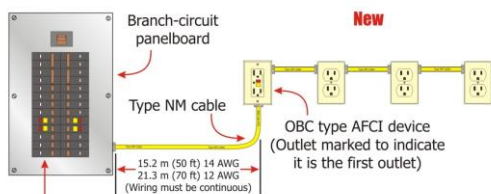

- (4) System Combination Type AFCI. A listed outlet branch circuit type AFCI installed at the first outlet in combination with a listed branch circuit over-current protective device (with four limiting conditions) (OCPD & OBC AFCI device must be identified and listed as "System Combination" type AFCI)

---

---

---

---

---

---

---

---

---

---

### 210.12(A) AFCI Protection



All 120-volt, single phase, 15- and 20-ampere branch circuits supplying outlets or devices installed in specified areas of dwelling unit shall be protected by any of the means described in (1) through (6):

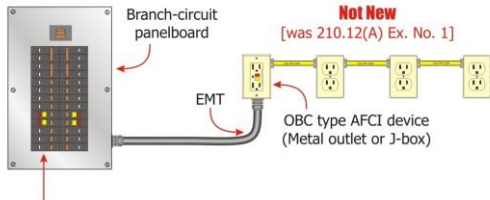

Listed branch circuit OCPD (circuit breaker or fuse)

(5) A listed outlet branch-circuit type AFCI device (first outlet) is permitted with RMC, IMC, EMT, Type MC, steel armored Type AC cables, metal wireways, or metal auxiliary gutters and metal outlet and junction boxes installed for the portion of the branch circuit between the OCPD and the first outlet

Copyright © IAEI 2014

---

---

---

---

---

---

---

---

---

---

### 210.12(A) AFCI Protection



All 120-volt, single phase, 15- and 20-ampere branch circuits supplying outlets or devices installed in specified areas of dwelling unit shall be protected by any of the means described in (1) through (6):

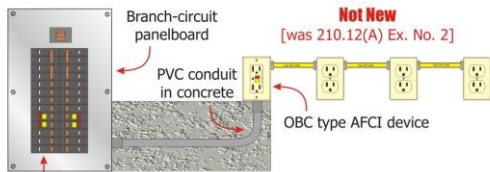

Listed branch circuit OCPD (circuit breaker or fuse)

(6) Where a listed metal or nonmetallic conduit or tubing or Type MC cable is encased in not less than 50mm (2 in.) of concrete for the portion of the branch circuit between the OCPD and the first outlet, it shall be permitted to install a listed outlet branch circuit type AFCI at the first outlet

Copyright © IAEI 2014

---

---

---

---

---

---

---

---

---

---

### 210.12 Arc-Fault Circuit-Interrupter Protection



Listed Outlet Branch-Circuit Type AFCI Devices

Listed Combination Overcurrent Protection Type AFCI Device



Courtesy of Pass & Seymour/Legrand

Courtesy of Eaton Corporation

Copyright © IAEI 2014

---

---

---

---

---

---

---

---

---

---

210.12(B) AFCI - Extensions or Modifications

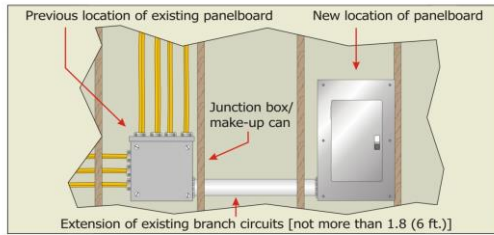

In any of the areas specified in 210.12(A), where branch-circuit wiring is modified, replaced or extended, the branch circuit shall be protected by:

- (1) A listed combination AFCI located at the origin of the branch circuit, or
- (2) A listed outlet branch-circuit AFCI located at the first receptacle outlet of the existing branch circuit

**Exception:** AFCI protection is not required where the extension is not more than 1.8 m (6 ft.) and does not include any additional outlets or devices

Copyright © IAEI 2014

---

---

---

---

---

---

---

---

---

---

210.12(B) AFCI - Extensions or Modifications

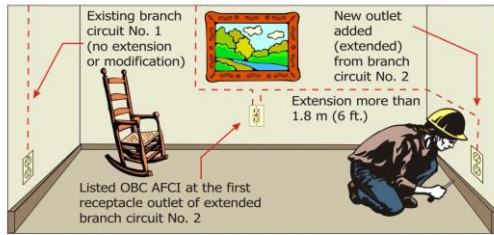

In any of the areas specified in 210.12(A), where branch-circuit wiring is modified, replaced or extended, the branch circuit shall be protected by:

- (1) A listed combination AFCI located at the origin of the branch circuit, or
- (2) A listed outlet branch-circuit AFCI located at the first receptacle outlet of the existing branch circuit

**Exception:** AFCI protection is not required where the extension is not more than 1.8 m (6 ft.) and does not include any additional outlets or devices

Copyright © IAEI 2014

---

---

---

---

---

---

---

---

---

---

210.13 GFPE: Branch Circuits

- GFP of equipment now required for **branch circuit** disconnects meeting provisions described at 230.95
- New section requires each branch circuit disconnect rated **1000 amperes or more** and installed on **solidly grounded wye electrical systems** of more than 150 volts to ground (but not exceeding 600 volts) to be provided with GFPE
- New language for branch circuits was crafted after the existing language at 215.10 for feeders
- **Exceptions** were also added for GFP provisions:
  - creating additional or increased hazards
  - already provided on the supply side of branch circuit

Copyright © IAEI 2014

---

---

---

---

---

---

---

---

---

---



---

---

---

---

---

---

---

---

### 210.17 Electric Vehicle Branch Circuit

- Outlet(s) installed for the purpose of charging electric vehicles required to be supplied by a **separate branch circuit** with no other outlets
- Charging an electric vehicle (EV) with an existing 120 volt receptacle outlet will typically overload an existing general purpose branch circuit
- It should be noted that this new requirement does not demand that an outlet(s) for the specific and sole purpose of charging EV equipment be installed
- A new I-Note was also added giving guidance to 625.2 for the definition of an "Electric Vehicle"

Copyright © IAEEI 2014

---

---

---

---

---

---

---

---



---

---

---

---

---

---

---

---

### 210.52(E)(3) Balconies, Decks and Porches



Copyright © IAET 2014

Balconies, decks and porches that are attached to the dwelling unit and are accessible from inside the dwelling unit shall have at least one receptacle outlet accessible from the balcony, deck or porch

The receptacle outlet shall not be located more than 2.0 m (6½ ft) above the balcony, deck, or porch walking surface

---

---

---

---

---

---

---

---

---

---



---

---

---

---

---

---

---

---

---

---



Outlet no longer required to be installed "within the perimeter of the balcony, deck or porch"

---

---

---

---

---

---

---

---

---

---



### 210.52(G)(1) Dwelling Unit Garages

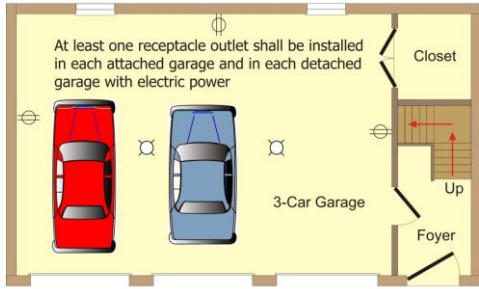

The branch circuit supplying this receptacle(s) shall not supply outlets outside of the garage  
At least one receptacle outlet shall be installed for each car space

Copyright © JAEI 2014

---

---

---

---

---

---

---

---

---

---

---

---



---

---

---

---

---

---

---

---

---

---

---

---

### 210.64 Electrical Service Areas

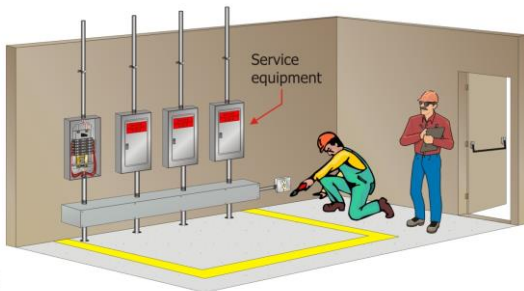

At least one 125-volt, single phase, 15 or 20 ampere rated receptacle outlet shall be installed within 15 m (50 ft) of the electrical service equipment  
Exception for one and two family dwellings

Copyright © JAEI 2014

---

---

---

---

---

---

---

---

---

---

---

---



---

---

---

---

---

---

---

---

### 250.8 Grounding and Bonding Connections

(A) Permitted Methods. Equipment grounding conductors, grounding electrode conductors, and bonding jumpers shall be connected by one or more of the following means:

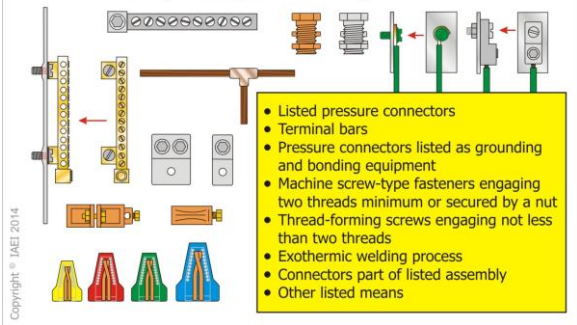

---

---

---

---

---

---

---

---

### 250.64(B) GEC Installation

New provisions added to clarify that grounding electrode conductors and grounding electrode bonding jumpers are **not required to comply with 300.5** for underground installations

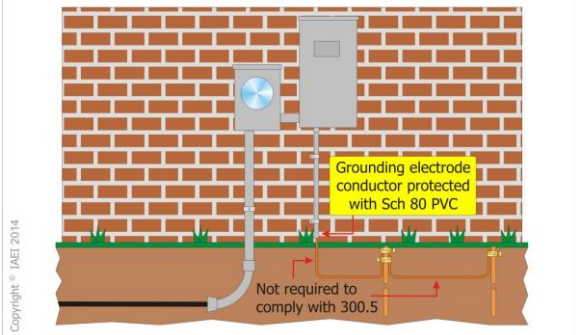

---

---

---

---

---

---

---

---



---

---

---

---

---

---

---

---

**250.66(A) and (B) GEC "Sole Connections"**

Explanatory language and plural text was added to clarify that the "sole connection" provisions pertains to the types of electrodes involved  
 The "sole connection" sizing provisions are not forfeited if more than one of the specified types of electrodes involved are present

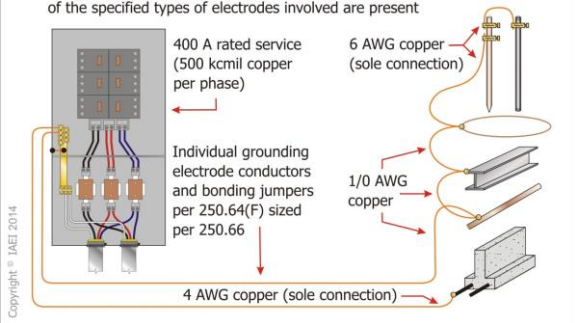

---

---

---

---

---

---

---

---

**250.68(C) Grounding Electrode Connections**

The title of 250.68(C) has been changed to "Grounding Electrode Connections"

Above-grade structural metal frame of a building can serve as a conductor **without having to be connected directly to a grounding electrode or qualify as a grounding electrode** as previously required

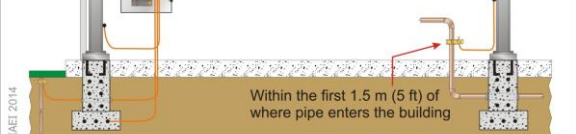

Interior metal water piping and the metal structural frame of a building are permitted as a means of interconnecting electrodes that are part of the grounding electrode system

---

---

---

---

---

---

---

---



---

---

---

---

---

---

---

---

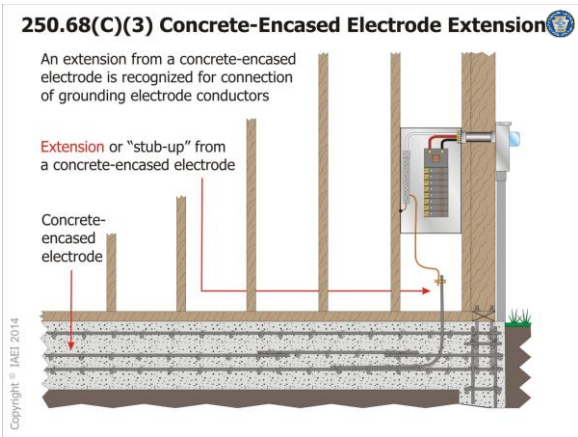

---

---

---

---

---

---

---

---



---

---

---

---

---

---

---

---

### Table 250.102(C)(1) Sizing Grounded Conductors, Main Bonding Jumpers, Etc.

- New **Table 250.102(C)(1)** added for sizing grounded conductors, main bonding jumpers, system-bonding jumpers, and supply-side bonding jumpers (*rather than Table 250.66*)
- References to this new table were revised throughout Article 250
- Table 250.66 is titled for GECs with a max. required conductor of 3/0 copper or 250 kcmil aluminum
- Table 250.122 will continue to be used for sizing fault-return carrying conductors, such as equipment grounding conductors, if the supply conductors have overcurrent protection on the supply side

Copyright © IAEI 2014

---

---

---

---

---

---

---

---

---

---

---

---

### Table 250.102(C)(1) Grounded Conductor, Main Bonding Jumper, System Bonding Jumper, and Supply-Side Bonding Jumper for Alternating-Current Systems

Size of Largest Ungrounded Conductor or Equivalent Area for Parallel Conductors (AWG/kcmil)		Size of Grounded Conductor or Bonding Jumper* (AWG/kcmil)	
Copper	Aluminum or Copper-Clad Aluminum	Copper	Aluminum or Copper-Clad Aluminum
2 or smaller	1/0 or smaller	8	6
1 or 1/0	2/0 or 3/0	6	4
2/0 or 3/0	4/0 or 250	4	2
Over 3/0 through 350	Over 250 through 500	2	1/0
Over 350 through 600	Over 500 through 900	1/0	3/0
Over 600 through 1100	Over 900 through 1750	2/0	4/0
Over 1100	Over 1750	See Notes	

\*For the purposes of this table, the term bonding jumper refers to main bonding jumpers, system bonding jumpers, and supply-side bonding jumpers.

Notes:

[See NEC for complete text of notes to Table 250.102(C)(1)]

Copyright © IAEI 2014

---

---

---

---

---

---

---

---

---

---

---

---



For Sizing of Grounded Conductors, Use New Table 250.102(C)(1)

---

---

---

---

---

---

---

---

---

---

---

---

### 250.186 Ground-Fault Circuit Conductor Brought to Service Equipment

- New 250.186 to require services (over 1000 volts) to have a **grounded conductor** to be brought to the service for a grounded system
- Ungrounded systems (over 1000 volts) will require a **supply-side bonding jumper** brought to the service
- Same requirements as 250.24(C) for services 1000 volts or below
- Primary concern is to provide a very low impedance ground-fault return path from any point on the wiring system where a ground fault may occur to the electrical supply source

Copyright © IAEI 2014

---

---

---

---

---

---

---

---

---

---

### 250.186 Ground-Fault Circuit Conductor Brought to Service Equipment

New 250.186 to require services (over 1000 volts) to have a **grounded conductor** brought to the service for a grounded system

Ungrounded systems (over 1000 volts) require a **supply side bonding jumper** brought to the service

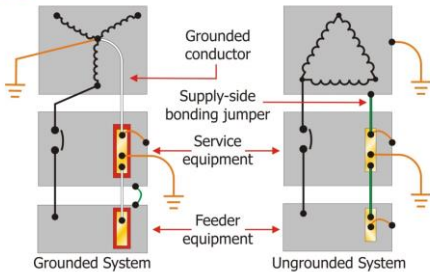

Copyright © IAEI 2014

---

---

---

---

---

---

---

---

---

---

### 300.6(A) Protection Against Corrosion

Ferrous metal raceways, etc. are typically required to be suitably protected against corrosion inside and outside

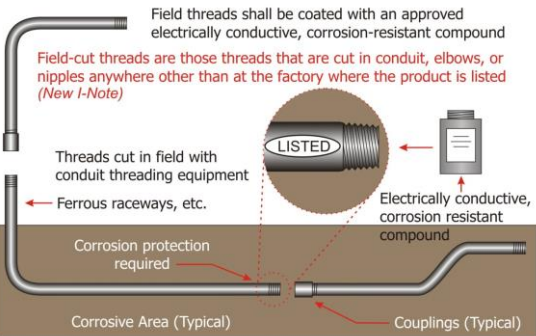

Copyright © IAEI 2014

---

---

---

---

---

---

---

---

---

---



---

---

---

---

---

---

---

---

### 300.38 Raceways in Wet Locations Abovegrade

The interior of raceways installed in wet locations abovegrade shall be considered to be a wet location (regardless of the voltage)

The interior of enclosures or raceways installed underground shall be considered to be a wet location (regardless of the voltage)

Insulated conductors and cables installed in raceways in wet locations (abovegrade or underground) shall comply with 310.10(C)

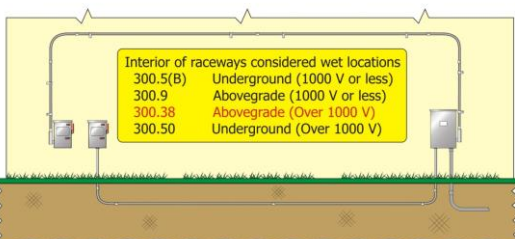

---

---

---

---

---

---

---

---

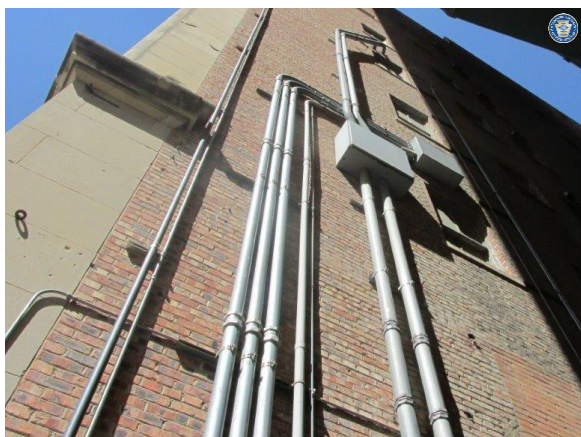

---

---

---

---

---

---

---

---

### 310.15(B)(3)(c) Raceways and Cables Exposed to Sunlight on Rooftops

- The title and parent text at 310.15(B)(3)(c) has been revised for clarity from "Circular Raceways Exposed to Sunlight on Rooftops" to "Raceways and Cables Exposed to Sunlight on Rooftops"
- Provisions for cables installed on or above rooftops have been added as well [previous language indicated that the cable(s) had to be installed in a raceway]
- A new exception was also added allowing Type XHHW-2 conductors (thermoset insulated conductor) to be installed in raceways or cables on rooftops without having to apply an ambient temperature adjustment correction factor for these conductors



Copyright © IAEI 2014

---

---

---

---

---

---

---

---

---

---

### 310.15(B)(3)(c) Raceways and Cables on Rooftops

Where raceways or cables are exposed to direct sunlight on or above rooftops, the adjustments shown in Table 310.15(B)(3)(c) shall apply

By exception, Type XHHW-2 insulated conductors shall not be subject to this ampacity adjustment

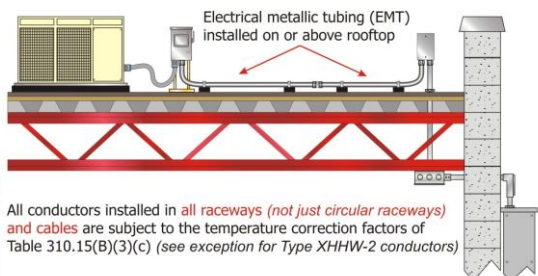

All conductors installed in all raceways (not just circular raceways) and cables are subject to the temperature correction factors of Table 310.15(B)(3)(c) (see exception for Type XHHW-2 conductors)

Copyright © IAEI 2014

---

---

---

---

---

---

---

---

---

---

### 310.15(B)(3)(c) Rooftop Adjustment Factors

**310.15(B)(3)(c) Circular Raceways and Cables Exposed to Sunlight on Rooftops.** Where conductors or cables are installed in circular raceways or cables are exposed to direct sunlight on or above rooftops, the adjustments shown in Table 310.15(B)(3)(c) shall apply.

**Exception:** Type XHHW-2 insulated conductors shall not be subject to this ampacity adjustment.

**Table 310.15(B)(2)(c) Ambient Temperature Adjustment for Raceways or Cables Exposed to Sunlight On or Above Rooftops**

Distance Above Roof to Bottom of Raceway or Cables	Temperature Added	
	°C	°F
On roof 0 - 13 mm (0 - 1/2 in.)	33	60
Above 13 mm (1/2 in.) - 90 mm (3 1/2 in.)	22	40
Above 90 mm (3 1/2 in.) - 300 mm (12 in.)	17	30
Above 300 mm (12 in.) - 900 mm (36 in.)	14	25

Informational Note to Table 310.15(B)(3)(c): The temperature adders in Table 310.15(B)(3)(c) are based on the measured temperature rise above the local climatic ambient temperatures due to sunlight heating.

Copyright © IAEI 2014

---

---

---

---

---

---

---

---

---

---



## 310.15(B)(7) 120/240 Volt, Single-Phase Dwelling Services and Feeders

- Previous **Table 310.15(B)(7)** has been **deleted** entirely
- The parent text at 310.15(B)(7) has been revised and broken up into four level 1 list items
- Revision allows the ampacity values found at Table 310.15(B)(16) to be reduced by 17 percent (*not less than 83 percent of the service or feeder rating*)
- A new informational note will take users of the Code to **Example D7** in **Informative Annex D** for an example of how to perform this dwelling unit service and feeder calculation

Copyright © IAEI 2014

---

---

---

---

---

---

---

---

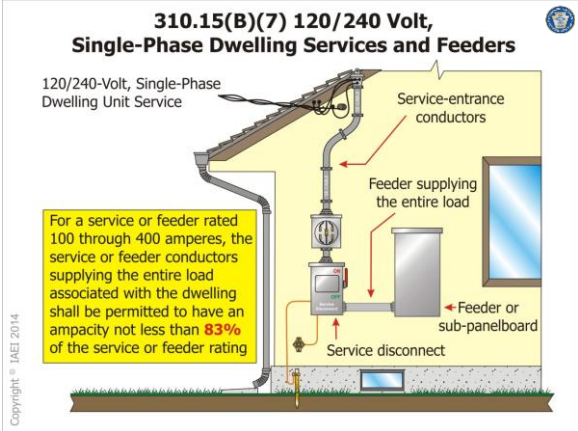

Copyright © IAEI 2014

---

---

---

---

---

---

---

---

## 314.27(A)(1) Vertical Surface Luminaire Outlets

- The title was changed from “Wall Outlets” to “**Vertical Surface Outlets**” as not all vertical surfaces where luminaire or lampholders are mounted are necessarily in or on a “wall”
- New language was also added to reflect that luminaires or lampholders can be mounted “on” a vertical surface as well as “in” a vertical surface
- The previous language only addressed boxes mounted “in a wall”
- An example of a “vertical” surface-mounted luminaire would be a luminaire mounted on the side of a square post in the middle of a large room or area

Copyright © IAEI 2014

---

---

---

---

---

---

---

---



---

---

---

---

---

---

---

---



---

---

---

---

---

---

---

---

**376.22 Number of Conductors and Ampacity (Metal Wireways)**

- Ampacity adjustment factors for more than three current-carrying conductors in a raceway shall only apply to metal wireways where the number of current-carrying conductors exceeds 30 **at any cross section of the wireway**
- Does not apply to simply 30 or more current-carrying conductors total in the wireway
- It was never intended for the adjustment factors of 310.15(B)(3)(a) to apply once there were more than 30 conductors total in the wireway as opposed to at a cross sectional area

Copyright © JAEI 2014

---

---

---

---

---

---

---

---



---

---

---

---

---

---

---

---

### 404.2(C) Grounded Conductor at Switch Locations

- The grounded conductor at switching location requirements and exceptions have been revised into positive text and rearranged into a list format
- Five new conditions were added along with the existing two conditions relaxing the requirement for a grounded conductor at all switch locations
- Requiring the presence of the grounded conductor is due in part to the influx of many electronic lighting control devices, such as occupancy sensors that require a standby current to maintain a ready state of detection for the function of these devices

Copyright © IAEI 2014

---

---

---

---

---

---

---

---

### 404.2(C) Grounded Conductor at Switch Locations

- 404.2 Switch Connections**
- (C) Switched Controlling Lighting Loads.** The grounded circuit conductor for the controlled lighting circuit shall be provided at the switch location where switches control lighting loads that are supplied by a grounded general purpose branch circuit for other than the following:
1. Where conductors for switches controlling lighting loads enter the box enclosing the switch through a raceway, provided that the raceway is large enough for all contained conductors, including a grounded conductor. The raceway shall have sufficient cross-sectional area to accommodate the extension of the grounded circuit conductor of the lighting circuit to the switch location whether or not the conductors in the raceway are required to be increased in size to comply with 310.15(B)(3)(a).

Copyright © IAEI 2014

---

---

---

---

---

---

---

---

### 404.2(C) Grounded Conductor at Switch Locations (cont.)

**404.2 Switch Connections**  
**(C) Switched Controlling Lighting Loads.** The grounded circuit conductor for the controlled lighting circuit shall be provided at the **switch** location where switches control lighting loads that are supplied by a grounded general purpose branch circuit for other than the following:

2. Where the box enclosing the switch is accessible for the installation of an additional or replacement cable without removing finish materials. ~~Cable assemblies for switches controlling lighting loads enter the box through a framing cavity that is open at the top or bottom on the same floor level, or through a wall, floor, or ceiling that is unfinished on one side.~~
3. Snap switches with integral enclosures complying with 300.15(E).

Copyright © IAEI 2014

---

---

---

---

---

---

---

---

---

---

---

---

### 404.2(C) Grounded Conductor at Switch Locations (cont.)

**404.2 Switch Connections**  
**(C) Switched Controlling Lighting Loads.** The grounded circuit conductor for the controlled lighting circuit shall be provided at the **switch** location where switches control lighting loads that are supplied by a grounded general purpose branch circuit for other than the following:

4. Where a switch does not serve a habitable room or bathroom.
5. Where multiple switch locations control the same lighting load such that the entire floor area of that room or space is visible from the single or combined switch locations.
6. Where lighting in the area is controlled by automatic means.
7. A switch controlling a receptacle load.

Copyright © IAEI 2014

---

---

---

---

---

---

---

---

---

---

---

---

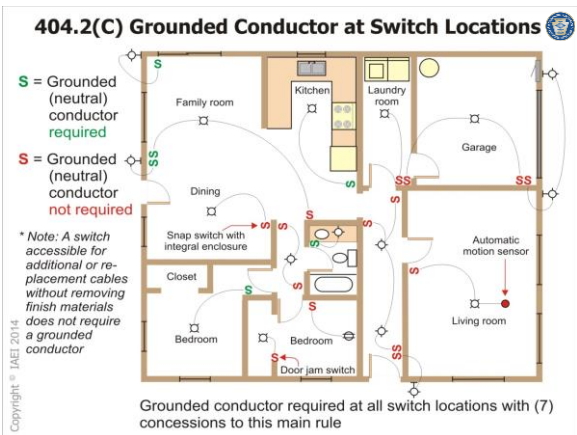

Copyright © IAEI 2014

---

---

---

---

---

---

---

---

---

---

---

---



---

---

---

---

---

---

---

---

### 406.3(E) and Figure 406.3(E) Controlled Receptacle Marking

- New marking symbol for receptacle outlets controlled by an automatic control device or by an automatic energy management system was added at 406.3(E)
- New Figure 406.3(E) was also added displaying new "Controlled Receptacle Marking" symbol 
- New exception added to indicate that this marking is not required for receptacle outlets controlled by a wall switch to provide the required room lighting outlet(s) as permitted by 210.70(A)(1) Ex. No. 1
- The occupant or end user needs to know which receptacle outlets will be automatically controlled and which receptacles will be energized continually
- It is important to be able to readily identify receptacle outlets that will be automatically powered on and off

Copyright © JAEI 2014

---

---

---

---

---

---

---

---

### 406.3(E) Controlled Receptacle Marking

All nonlocking-type, 125-volt, 15- and 20-ampere receptacles controlled by an automatic control device, energy management, or building automation shall be marked with the "Controlled Receptacle Marking Symbol" from Figure 406.3(E) placed on the controlled receptacle outlet where visible after installation







Copyright © JAEI 2014

---

---

---

---

---

---

---

---

### 406.4(D) Replacement Receptacles



AFCI and GFCI-type receptacles installed for replacement receptacles required to be installed in a readily accessible location

Copyright © IAEI 2014

---

---

---

---

---

---

---

---

### 406.5(E) Receptacles in Countertops and Similar Work Surfaces in Dwelling Units



Restriction to prohibit receptacles from being installed in the face-up position expanded to all occupancies (not just dwelling units)



Listed receptacle assemblies for countertop applications have been recognized for this application as well

Copyright © IAEI 2014

---

---

---

---

---

---

---

---

### 406.9(B)(1) 15- and 20-Ampere Receptacles in a Wet Location



- "Extra duty" covers are now required for all 15- and 20-ampere, 125- and 250-volt receptacles installed in a wet location (not just those supported from grade)
- If the receptacle is installed in a wet location, it should make no difference how the enclosure or device box is installed or supported when determining the need for an extra duty hood cover
- This requirement now also includes dwelling unit wet location receptacles as well
- The durability of the nonmetallic in-use cover hoods provided for compliance with these wet location requirements has been found to be less than desirable, especially on construction sites

Copyright © IAEI 2014

---

---

---

---

---

---

---

---



---

---

---

---

---

---

---

---



---

---

---

---

---

---

---

---

**406.12 Tamper-Resistant Receptacles**

Exception for tamper-resistant receptacles at dwelling units has been expanded to guest rooms and guest suites of hotels and motels and child care facilities

Tamper-resistant receptacles not required for receptacles:

- located more than 1.7 m (5½ ft) above floor
- that are part of a luminaire or appliance
- located within dedicated space for an appliance
- replacement nongrounding type

Copyright © JAET 2014

All nonlocking type 125-volt, 15- and 20-ampere receptacles in hotel/motel guest rooms/suites and child care facilities required to be listed tamper-resistant receptacles

---

---

---

---

---

---

---

---

### 408.4(B) Identification - Source of Supply

All non-dwelling unit switchboards, switchgear, and panelboards supplied by a feeder(s) shall be marked to indicate each device or equipment where the power originates

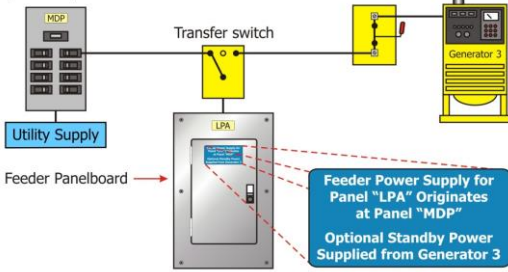

Copyright © JAEI 2014

Revisions occurred at 404.4(B) to indicate that switchboards, switchgear, and panelboards can have more than one source of power

---

---

---

---

---

---

---

---

---

---

### 410.6 Listing Required (Luminaires)

- Listing requirements for luminaires and lampholders expanded to "Retrofit Kits"
- A retrofit kit is, "a general term for a complete subassembly of parts and devices for field conversion of utilization equipment" (see Article 100)
- Extensive upgrades are underway in the lighting as well as the sign industries to achieve greater energy efficiency in luminaires and signs by replacing in-place illumination systems with light emitting diodes (LED) technology
- Involves field modifications of existing luminaires
- The changing of illumination systems in luminaires presents a hazard for electricians doing maintenance after the conversion if not installed using these listed subassembly retrofit kits and installed properly per the manufactures instructions

Copyright © JAEI 2014

---

---

---

---

---

---

---

---

---

---

### 410.6 Listing Required

Listing requirements for luminaires and lampholders have been expanded to "Retrofit Kits"



Copyright © JAEI 2014

---

---

---

---

---

---

---

---

---

---



### 422.5 GFCI Protection (Appliances)

- **GFCI devices** providing protection to appliances in Article 422 now required to be installed in **readily accessible locations**
- Manufacturers of GFCI protective devices routinely require that their GFCI device be tested on a monthly basis to ensure it is providing the life-safety protection intended
- GFCI devices installed in locations that are not readily accessible (*behind a vending machine*) greatly impairs the ability to test these GFCI devices
- Installation of these devices in readily accessible locations will greatly aid in this monthly testing process and at the very least, not hinder this testing process

Copyright © IAEEI 2014

---

---

---

---

---

---

---

---

---

---

---

---

### 422.5 GFCI Protection (Appliances)

GFCI devices providing protection to appliances in Article 422 required to be installed in **readily accessible locations**



Drinking fountains



Vending machines



High-pressure spray washers



Tire inflation/auto vac machines

Copyright © IAEEI 2014

---

---

---

---

---

---

---

---

---

---

---

---

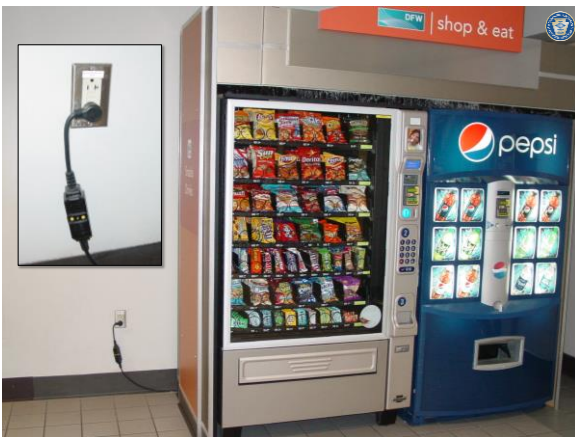

---

---

---

---

---

---

---

---

---

---

---

---

### 422.23 Tire Inflation and Automotive Vacuum Machines



- GFCI protection now required for all **tire inflation** and automotive **vacuum machines** provided for public use
- These machines are typically located in commercial applications such as convenience stores and car wash areas where they are heavily used by the general public
- This public-use equipment is typically exposed to the elements and is often misused to the point of abuse
- Fatalities have been reported in conjunction with tire-inflation and vacuum machines
- Requiring GFCI protection for this type of equipment will greatly reduce future electrical shock hazard related incidents

Copyright © IAEEI 2014

---

---

---

---

---

---

---

---

### 422.23 Tire Inflation and Auto Vacuum Machines



GFCI protection now required for all **tire inflation** and automotive **vacuum machines** provided for public use



Copyright © IAEEI 2014

---

---

---

---

---

---

---

---



---

---

---

---

---

---

---

---

### 422.51 Vending Machines

GFCI protection has been expanded to **hard-wired** vending machines as well as cord-and-plug-connected vending machines



Vending machines not utilizing a cord-and plug connection are required to be connected to a GFCI protected circuit

Copyright © IAEEI 2014



---

---

---

---

---

---

---

---

---

---

### 424.66 Installations (Duct Heaters)

- New provisions were put in place to require limited forms of **working space** about duct heaters for fixed electric space-heating equipment
- Requires duct heaters located in spaces above a ceiling to be accessible through a lay in type ceiling or access panel(s)
- The width of the required working space must be equal to the width of the enclosure or a minimum of 762 mm (30 in.), whichever is greater
- Any and all doors or hinged panels are required to have the ability to open to at least 90 degrees
- The space in front of the enclosure must comply with Table 110.26(A)(1) working space depth requirements with horizontal T-bar ceiling grid permitted in this space

Copyright © IAEEI 2014



---

---

---

---

---

---

---

---

---

---



---

---

---

---

---

---

---

---

---

---



---

---

---

---

---

---

---

---

### 445.20 GFCI Protection for Receptacles on 15-kW or Smaller, Portable Generators

All 125-volt, single-phase, 15-and 20 ampere receptacle outlets, on 15 kW or smaller, portable generators shall have GFCI protection for personnel:

- integral to the generator or receptacle, or...
- receptacle outlets shall not be available for use when the 125/250 volt locking-type receptacle is in use

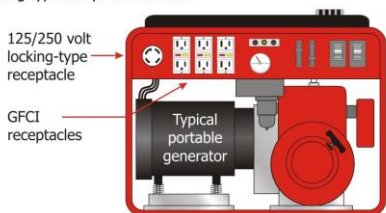

If the generator does not have a 125/250 volt locking-type receptacle, GFCI requirements not required

---

---

---

---

---

---

---

---

### TIA 70-14-2 for 445.20

- Revise 445.20 to read as follows:
- **445.20 Ground-Fault Circuit Interrupter Protection for Receptacles on 15 kW or Smaller Portable Generators.** All 125-volt, single-phase, 15-and 20-ampere receptacle outlets that are a part of a 15-kW or smaller portable generator either shall have ground-fault circuit-interrupter protection for personnel integral to the generator or receptacle or shall not be available for use when the 125/250-volt locking-type receptacle is in use. **If the generator was manufactured or remanufactured prior to January 1, 2015, listed cord sets or devices incorporating listed ground-fault circuit-interrupter protection for personnel identified for portable use shall be permitted.** If the generator does not have a 125/250-volt locking-type receptacle, this requirement shall not apply.
- Issue Date: October 22, 2013
- Effective Date: November 11, 2013

---

---

---

---

---

---

---

---



---

---

---

---

---

---

---

---

### 450.10 Grounding (Transformers)

- A grounding and bonding terminal bar for the purpose of landing grounding and bonding conductors must be bonded to the transformer enclosure, but cannot be mounted on or over any **vented screens** or openings
- This can result in a less than effective connection using a method that has not been evaluated as grounding and bonding equipment and should not be depended upon to serve as effective ground fault current return path
- New exception was also added addressing transformers equipped with wire-type connections (*pig-tail leads*)
- Grounding and bonding connections permitted to be connected together using any of the methods in 250.8 and must be bonded to the metal enclosure

Copyright © IAEEI 2014

---

---

---

---

---

---

---

---



---

---

---

---

---

---

---

---

### 517.18(B) Patient Bed Location Receptacles

The minimum number of receptacles required for general care area patient bed locations of health care facilities was **increased from four to eight receptacles**

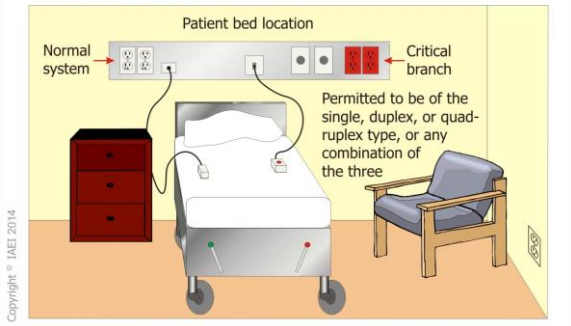

---

---

---

---

---

---

---

---



---

---

---

---

---

---

---

---

### 517.19(B) Patient Bed Location Receptacles

The minimum number of receptacles required for **critical care** area patient bed locations of health care facilities was **increased from six to fourteen receptacles**

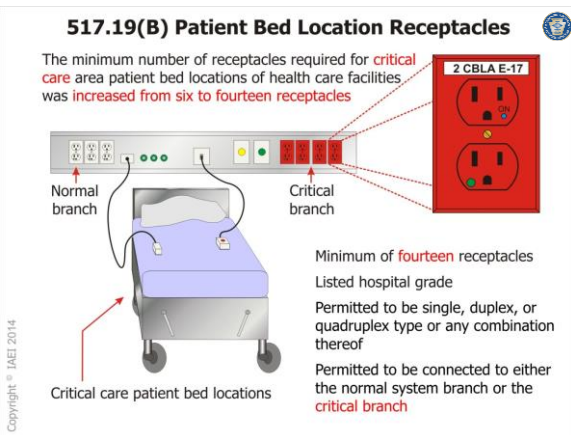

---

---

---

---

---

---

---

---



---

---

---

---

---

---

---

---

### 517.19(C) Operating Room Receptacles

New 517.19(C) was added requiring a minimum number of **thirty-six** receptacles in an operating room of a health care facilities



Copyright © IAEI 2014

At least **twelve** of the **thirty-six** receptacles required to be connected to either the normal system branch or the critical branch circuit supplied by a different transfer switch than the other receptacles at the same location

---

---

---

---

---

---

---

---



---

---

---

---

---

---

---

---

### 517.30(B) Essential Electrical Systems for Hospitals



Copyright © IAEI 2014

- The use of and term, “**Emergency Systems**” has been eliminated from Article 517 leaving only the essential system with the **three separate branches**:
  - Critical branch
  - Life safety branch
  - Equipment branch
- The diagram in Figure 517.30, No. 1 had been re-worked to reflect these changes as well
- In an effort to correlate the requirements of the *NEC* and in particular, Article 517 with NFPA 99 (*Health Care Facilities Code*), 517.30(B) was re-organized for the make-up of the **essential system of a hospital**
- The term “Emergency System” is no longer used in Article 517, removing major confusion resulting from the previous use of the word “emergency” in similar, yet sometimes quite different, ways in Article 517 from Article 700

---

---

---

---

---

---

---

---

---

---

### 517.30(B) Essential Electrical System (Hospital)



Copyright © IAEI 2014

- Essential electrical systems for hospitals shall be comprised of **three separate branches** capable of supplying a limited amount of lighting and power service that is considered essential for life safety and effective hospital operation during the time the normal electrical service is interrupted for any reason
- The **three branches** are life safety, critical, and equipment branches

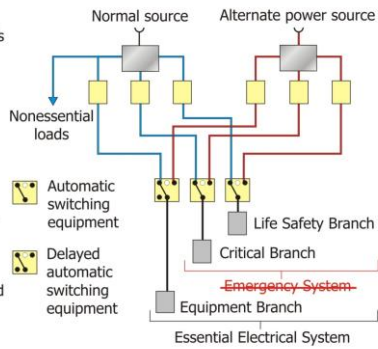

---

---

---

---

---

---

---

---

---

---



---

---

---

---

---

---

---

---

---

---



### 590.4(J) Support (Temporary Installations)



Cable assemblies and flexible cords installed as branch circuits or feeders now prohibited from being installed or laid on the floor or the ground for temporary installations such as construction sites (does not include extension cords)



Copyright © IAET 2014

Cable assemblies and flexible cords and cables shall be supported in place at intervals that ensure that they will be protected from physical damage

---

---

---

---

---

---

---

---

---

---



---

---

---

---

---

---

---

---

---

---



---

---

---

---

---

---

---

---

---

---

### 680.21(C) GFCI Protection (Motors)

All single-phase, 120 volt through 240 volt outlets supplying pool pump motors now require GFCI protection (*regardless of ampacity*)

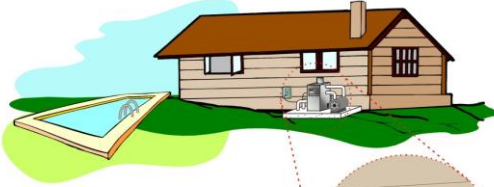

Outlets supplying pool pump motors require protection under the following conditions:

- Rated 15 or 20 amperes
- 120 volt through 240 volt
- Single phase
- Receptacle or direct connection
- Regardless of location

Copyright © JAEI 2014



---

---

---

---

---

---

---

---

---

---



---

---

---

---

---

---

---

---

---

---

### 680.22(A)(1) Required Receptacle - Location

At least one 125-volt, 15- or 20-ampere receptacle on a general-purpose branch circuit must be located not less than 1.83 m (6 ft) from, and not more than 6.0 m (20 ft) from, the inside wall of all permanently installed pools (*not just dwelling unit pools*)

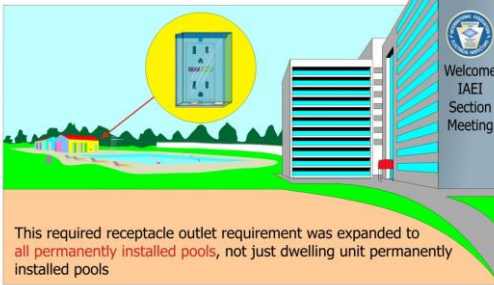

This required receptacle outlet requirement was expanded to all permanently installed pools, not just dwelling unit permanently installed pools

Copyright © JAEI 2014



---

---

---

---

---

---

---

---

---

---



---

---

---

---

---

---

---

---



---

---

---

---

---

---

---

---

**690.12 Rapid Shutdown of PV Systems on Buildings**

- New provisions added for **"Rapid Shutdown"** of PV systems on buildings
- PV source circuits required to be de-energized from all sources within **10 seconds** of when the utility supply is de-energized or when the PV power source disconnecting means is opened
- This is an effort to increase the electrical and fire safety on buildings for **emergency and fire service first and second responders** during emergency operations on PV-equipped buildings and structures
- There is a need for the ability to de-energize PV-generated power sources in the event of an emergency

Copyright © JAEI 2014

---

---

---

---

---

---

---

---

## 690.12 Rapid Shutdown of PV Systems on Buildings (cont.)

- New section will address the **de-energizing of rooftop wiring** leaving only the module wiring and internal conductors of the module still energized
- PV source circuit conductors include all wiring between modules or modular electronic devices up to the combining point
- An electronic means will be necessary to shutdown the module at the source circuit level
- **PV module-level dc-dc converter, single-module micro-inverter, and ac module** can all meet this requirement at the module end of the circuit
- Simple **remotely controlled electronic switches** can also meet this requirement
- A voltage limit of **30-volts** and a power limit of **240 watts** were established as a safe power limited environment

Copyright © IAEEI 2014

---

---

---

---

---

---

---

---

---

---

## 690.12 Rapid Shutdown of PV Systems on Buildings

PV source circuits to be de-energized from all sources within 10 seconds of when the utility supply is de-energized or when the PV power source disconnecting means is opened

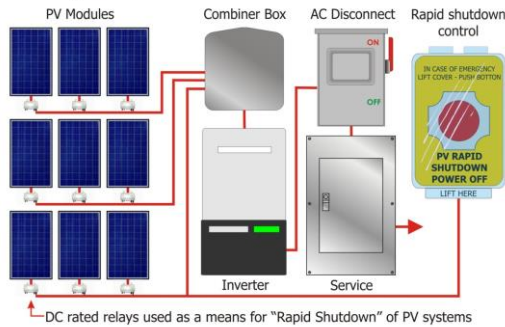

Copyright © IAEEI 2014

---

---

---

---

---

---

---

---

---

---

## 690.41 System Grounding (PV Systems)

This section for "System Grounding" was revised into a **list format** for clarity  
Reference to **"over 50"** volts was **deleted** (applies to all PV systems at any voltage)

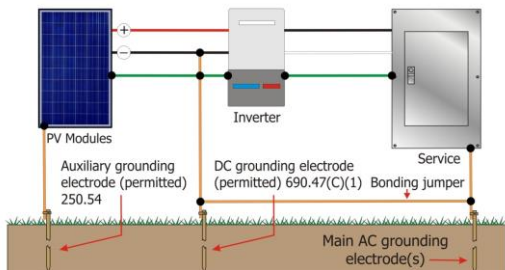

The term **"solidly"** grounded was **removed** for consistency  
An allowance for **impedance grounding** and the reference to 690.5 (GFP) was also added for clarity when grounded 2-wire and bipolar PV systems are installed

Copyright © IAEEI 2014

---

---

---

---

---

---

---

---

---

---



---

---

---

---

---

---

---

---

### 702.7(C) Signs for Power Outlet (Optional Standby Systems) (cont.)

- Optional standby system power inlets used for a temporary connection to a portable generator require a **warning sign** to be placed **near the inlet** to indicate the type of derived system involved (*bonded or floating neutral*)

**WARNING:  
FOR CONNECTION OF A SEPARATELY DERIVED  
(BONDED NEUTRAL) SYSTEM ONLY**

OR

**WARNING:  
FOR CONNECTION OF A SEPARATELY DERIVED  
(FLOATING NEUTRAL) SYSTEM ONLY**

Copyright © JAEI 2014

---

---

---

---

---

---

---

---

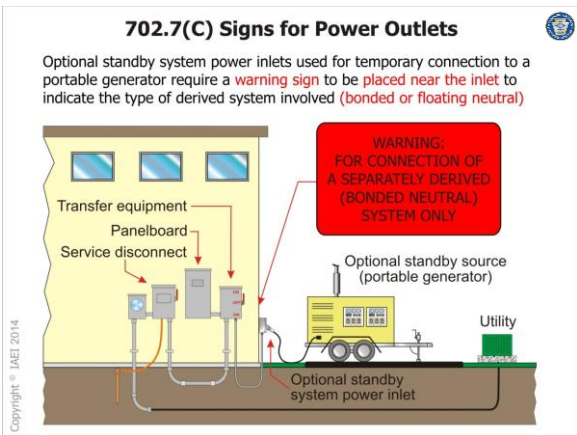

---

---

---

---

---

---

---

---

### 810.6 Antenna Lead-In Protectors

New provisions added at 810.6 requiring radio and television equipment **antenna lead-in surge protectors** (when installed) to be **listed** as being suitable for limiting surges on the cable that connects the antenna to the receiver/transmitter electronics



Antenna lead-in surge protector is required to be connected between the conductors and the grounded shield or other ground connection

Copyright © IAETI 2014

---

---

---

---

---

---

---

---

---

---

---

---

## Chapter Nine Tables



---

---

---

---

---

---

---

---

---

---

---

---

### Chapter 9 Tables: Notes to Tables - Note (10)

A new **Note (10)** was added to the Chapter 9 Notes to Tables indicating that the values for approximate conductor diameter and area shown in Table 5 are based on worst-case scenario

Table 5 is based on round concentric-lay-stranded conductors with **solid** and round concentric-lay-stranded conductors **grouped together** for the purpose of Table 5

Round **compact-stranded conductor** values are shown in Table 5A

This new note gives the user of the *Code* permission to use the **actual values of the conductor diameter and area** if they are known

Solid Conductor



8 AWG THWN  
Dia = 5.486 mm  
(0.216 in.)  
Area = 23.61 mm<sup>2</sup>  
(0.0366 in.<sup>2</sup>)

Standard Stranding



8 AWG XHHW  
Dia = 5.994 mm  
(0.236 in.)  
Area = 28.19 mm<sup>2</sup>  
(0.0437 in.<sup>2</sup>)

Compact Stranding



8 AWG XHHW  
Dia = 5.690 mm  
(0.224 in.)  
Area = 25.42 mm<sup>2</sup>  
(0.0394 in.<sup>2</sup>)

Copyright © IAETI 2014

---

---

---

---

---

---

---

---

---

---

---

---

ANALYSIS OF CHANGES – 2014 *NEC*



Training Presentation by:  
International Association of Electrical Inspectors

---

---

---

---

---

---

---

---