

Choose the Joyce/Dayton options, accessories and motor controls needed to complete your jack system.

We offer everything from protective boots and anti-backlash devices to special materials and finishes. The information needed to complete a system can be found on the pages that follow.

Select components for single- or multiple-jack systems. Choose miter boxes, pillow block supports, shafting and couplings.

Finish the system with a standard motor control, or let us know your requirements. We offer an extensive line of motor starters as well as programmable controls for synchronized systems and leveling systems.

Joyce/Dayton has been designing systems for decades. Our experienced application engineers can help you put it all together. Contact us today.



OPTIONS, ACCESSORIES AND CONTROLS

Boots 170-172
Trunnion Mounts 173
Limit Switches 174-175
Potentiometers 176
Hand Wheels and Counters 177
Encoders 178

Special Finishes 179
Anti-backlash Devices 180-181
Miter Gear Boxes 182-184
Motor Mounts and Stock Motors 185
Pillow Blocks and Flange Blocks 186-187
Couplings 188-189

Shafting 190-191
Motor Starter Controls 192
VSPS Controls 193
Linear Actuator Controls 194
System Arrangements 195



OPTIONS PROTECTIVE BOOTS

For Translating and Keyed Design Machine Screw Jacks

Joyce boots protect the screw from dust, dirt, and help maintain proper lubrication. Standard boots, fabricated from neoprene-coated nylon, also guard against moisture and corrosive contaminants. For travel distances up to 24 inches, boots are designed in 3 inches increments; for travel distances over 24 inches boots are designed for the specific travel distance (rise).

Adding protective boots may increase the closed height of the jack depending on the end condition and the amount of travel (rise) required. For instance, the chart below indicates that the closed height of a one-ton upright jack with a T2 end will increase only if the travel is greater than 9 inches.

Contact Joyce/Dayton for:

- Zippered boots
- Boots for extreme temperatures (-40°F – 500°F)
- Boots for corrosive atmospheres
- Boots for bevel gear jacks and bevel ball actuators

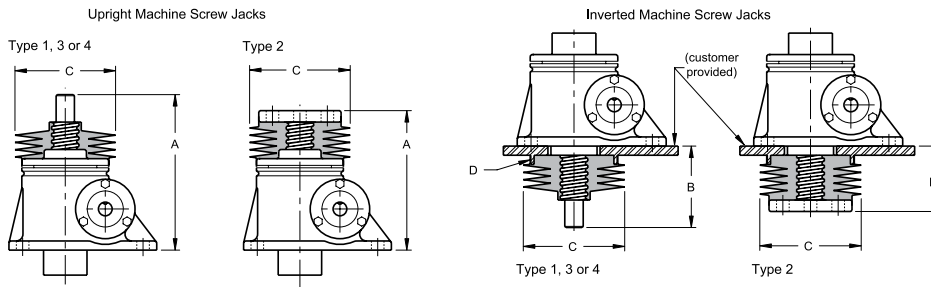

Jack Capacity	A - Closed Height for Upright Jack				Max. Travel Without Increasing Closed Height - Upright Type 2**	B - Closed Height for Inverted Jack				C O.D. of Boot	D Collar Diameter
	Type 1*	Type 2	Type 3*	Type 4*		Type 1*	Type 2*	Type 3*	Type 4*		
250/500 Lb.	4 1/2	4	4 1/2	3 3/4	12	2 3/4	1 5/8	2 3/4	2	3	2 5/16
1,000 Lb.	4	4	4	4	12	3	2	3	2 1/4	3	2 5/16
1 Ton	5 3/8	4 1/2	5 3/8	5 3/8	9	2 1/2	1 15/16	2 1/2	2 1/2	5	2 3/4
2 Ton	6	5 5/16	6	6 1/4	3	2 7/8	2 1/16	2 7/8	3 3/16	5	3 3/4
3 Ton	5 15/16	5 1/4	5 15/16	6 3/4	0	2 5/8	1 15/16	2 5/8	3 1/2	5	3 3/4
5 Ton	7 3/4	7 1/16	7 3/4	8 1/4	6	3 7/8	2 11/16	3 7/8	4 3/8	5 1/2	4 3/4
10 Ton	8	7 1/4	8	8 11/16	9	4	2 1/2	4	4 11/16	6 1/2	5 3/4
15 Ton	8 3/4	8	8 3/4	9 7/16	9	4	2 1/2	4	4 11/16	6 1/2	5 3/4
20 Ton	9 15/16	9 1/4	9 15/16	10 3/4	9	3 15/16	2 1/2	3 15/16	4 3/4	6 1/2	6
25 Ton	11 3/8	11	12 1/4	12 3/4	9	4 1/16	2 7/8	4 15/16	5 7/16	8	7 1/2
30 Ton	11 15/16	11 1/2	11 3/16	17 1/16	21	4 15/16	4 1/8	4 3/16	9 11/16	8	8 1/4
35 Ton	13 5/8	12	13 5/8	13 5/8	0	6 11/16	5 1/16	6 11/16	6 11/16	10	8 1/2
50 Ton	18	14 3/8	18	18	0	10 5/8	7	8 3/8	9 1/8	13	11 5/8
75 Ton	20 1/2	16 1/2	20 1/2	20 1/2	0	9 7/8	5 13/16	7 3/4	7 7/8	13	13 1/2
100 Ton	20 1/4	19	20 1/4	21 1/4	0	9 7/8	6 7/16	8 3/8	8 7/8	14 1/2	15

150-ton and 250-ton dimensions supplied upon request.

* Closed height given must be increased by 0.071" for each 1" of travel.

** Upright Type 2 closed height must be increased by 0.071" for each 1" over the maximum given.

Note: Drawings are artist's conception — not for certification; dimensions are subject to change without notice.

OPTIONS PROTECTIVE BOOTS

For Translating Design Ball Screw Jacks

Joyce boots protect the screw from dust, dirt, and help maintain proper lubrication. Standard boots, fabricated from neoprene-coated nylon, also guard against moisture and corrosive contaminants. For travel distances up to 24 inches, boots are designed in 3 inches increments; for travel distances over 24 inches, boots are designed for the specific travel distance (rise).

Adding protective boots may increase the closed height of the jack depending on the end condition and the amount of travel (rise) required. For instance, the chart below indicates that the closed height of a one-ton (WBL) upright jack with a T4 end will increase only if the travel is greater than 6 inches.

Contact Joyce/Dayton for:

- Zippered boots
- Boots for extreme temperatures (-40°F – 500°F)
- Boots for corrosive atmospheres
- Boots for bevel gear jacks and bevel ball actuators

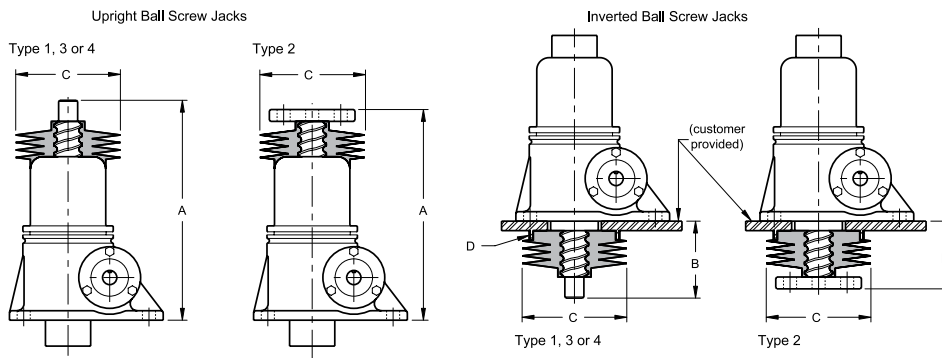

Note: Adding a protective boot increases closed height.
 ▲ The closed height of Type 4 jacks remains the same up to the maximum travel given in the chart below.

Jack Capacity	A - Closed Height for Upright Jack				▲ - Type 4**	B - Closed Height for Inverted Jack				▲ - Type 4**	C O.D. of Boot	D Collar Diameter
	Type 1*	Type 2*	Type 3*	Type 4*		Type 1*	Type 2*	Type 3*	Type 4*			
1 Ton WBL	6 7/16	6 1/4	6 7/16	7 1/4	6	2 5/8	2 1/4	2 5/8	2 7/8	0	5	2 3/4
1 Ton WB	7 7/16	7 1/4	7 7/16	8 1/4	9	2 5/8	2 1/4	2 5/8	2 7/8	0	5	2 3/4
2 Ton	8 3/8	7 3/4	8 3/8	9 5/8	12	3 1/4	2 9/16	3 1/4	3 5/8	0	5	2 3/4
5 Ton	10 1/2	11	10 1/2	13 3/8	18	3 13/16	3 5/16	3 13/16	5 3/16	0	5 1/2	4 3/4
10 Ton WBL/HWBL	11 1/4	10 5/16	11 1/4	13 1/16	15	4 7/16	3 7/16	4 7/16	5 3/16	0	6 1/2	5 3/4
10 Ton WB/HWB	15	14 1/2	15	16 3/4	18	4 15/16	3 3/4	4 15/16	5 1/2	0	6 1/2	5 3/4
20 Ton	17 3/16	16 5/8	17 3/16	20 5/16	27	4 3/4	3 7/16	4 3/4	6 1/2	9	6 1/2	6
30 Ton	23 1/4	22 9/16	23 1/4	28 5/16	42	6 1/4	4	6 1/4	10	24	8	8 1/4
50 Ton	27 3/16	26 7/16	27 3/16	32 1/2	45	6 11/16	4 15/16	6 11/16	10 1/4	21	13	11 5/8

* Closed height given must be increased by 0.071" for each 1" of travel.
 ** Type 4 closed height must be increased by 0.071" for each 1" over the maximum given.

Note: Drawings are artist's conception — not for certification; dimensions are subject to change without notice.

OPTIONS PROTECTIVE BOOTS

For Traveling Nut Design Machine and Ball Screw Jacks

Joyce boots for Traveling Nut (KFTN, rotating screw) Jacks protect the screw from dust, dirt, and help maintain proper lubrication. Standard boots, fabricated from neoprene-coated nylon, also guard against moisture and corrosive contaminants.

KFTN design jacks require an upper and lower boot to cover the rotating lifting screw. Diagrams of upright and inverted machine screw jacks are shown. Refer to the chart below to find the outside boot diameter, sleeve diameter, and the large and small diameter of the traveling nut. (When mounting boots to ball screw jacks, do not attach them to the small traveling nut diameter.)

Adding dual protective boots increases the closed height and screw length of KFTN jacks. Since many mounting configurations exist, customers will need to provide additional mounting detail.

Contact Joyce/Dayton for:

- Specific mounting options for ball screw jacks
- Specific mounting options for machine screw jacks
- Zippered boots
- Boots for extreme temperatures (-40°F – 500°F)
- Boots for corrosive atmospheres
- Boots for bevel gear jacks and bevel ball actuators

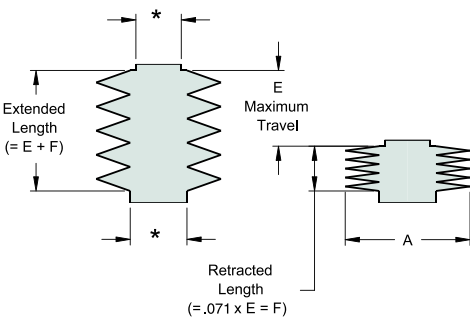
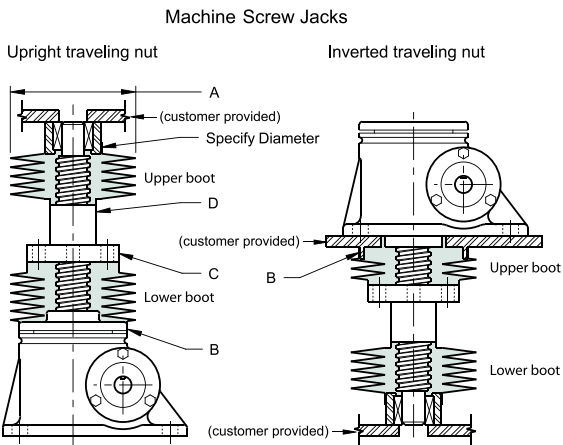

* Be sure to specify the collar diameter of boot ends that attach to flanges on your mounting structure.

Jack Capacity	A O.D. of Boot	B Collar Diameter	C - Collar Diameter		D - Collar Diameter Machine Screw Jacks Only**
			ACME Nut	Ball Nut	
250/500 Lb.	3	2 5/16	2 1/4		1
1,000 Lb.	3	2 5/16	2 1/4		1
1 Ton	5	2 3/4	3 1/4	2 5/8	1 1/2
2 Ton	5	3 3/4	3 1/4	3 1/4	1 1/2
3 Ton	5 1/2	3 3/4	3 1/4		2
5 Ton	5 1/2	4 3/4	4	4 15/16	2
10 Ton	6 1/2	5 3/4	6	5 3/8	3
15 Ton	6 1/2	5 3/4	6 1/2		3 1/2
20 Ton	6 1/2	6	7 1/2	5 3/8	3 3/4
25 Ton	8	7 1/2	8 1/2		4 1/2
30 Ton	8	8 1/4	7 3/8	7 3/8	4 1/2
35 Ton	10	8 1/2	9		5
50 Ton	10	11 5/8	10	9 3/4	6
75 Ton	13	13 1/2	12		7
100 Ton	14 1/2	15	12 3/4		8

**Boot collars do not fit small end of ball nuts.

Note: Drawings are artist's conception — not for certification; dimensions are subject to change without notice.

OPTIONS TRUNNION MOUNTS

Options – Trunnion Mounting Adapters

Trunnion adapter plates bolt to the base of 2-ton through 20-ton jacks. They include precision bores for trunnion pins. These are frequently used in installations where a single* jack moves through an arc during operation. This jack is often configured with a motor mount or as a ComDRIVE®.

Design Information

The customer supplied trunnion pins should be ground to the “D” diameter shown in the table below. These pins should be made of steel with hardness greater than 30 HRC, a yield strength greater than 60,000 psi and be supported to within 1/16 inch of the trunnion adapter plate. Therefore the distance between the customer’s mounting surfaces should be no more than “A” + 0.13 inch.

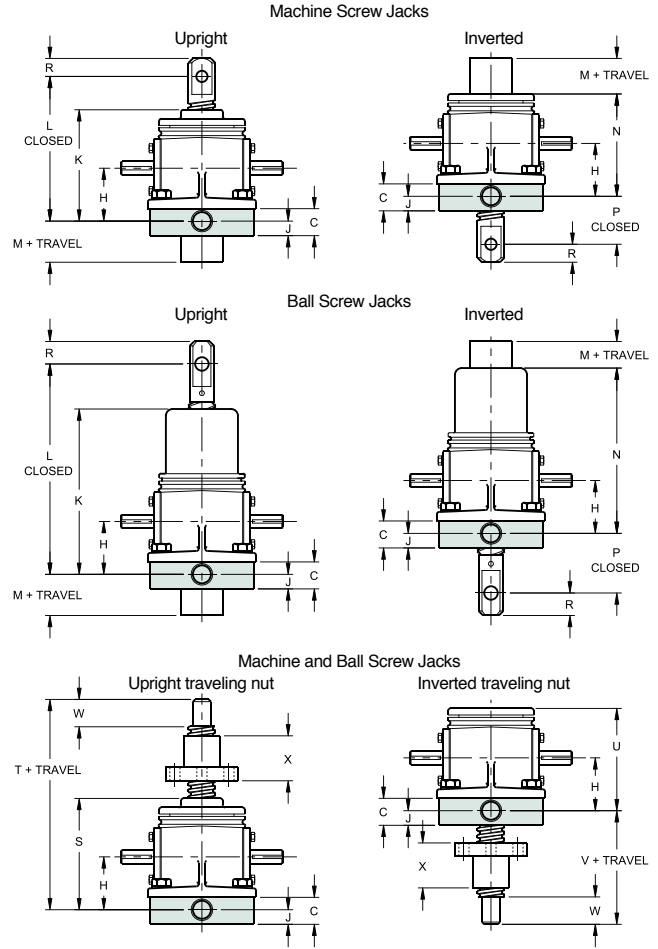
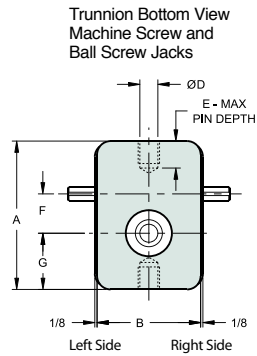

Jack Model	Common Dimensions										Upright - Inverted						Upright - Inverted Traveling Nut					
	A	B	C	D	E	F	G	H	J	K	L	M	N	P	R	S	T	U	V	W	X	
Machine Screw	2 Ton RWJT/DRWJ	7 1/4	3 1/4	1 1/4	.7491 .7479	1 1/4	1.703	3 1/8	2 5/16	11/16	4 11/16	5 3/8	0	4 5/16	2 1/16	11/16	4 11/16	8 3/16	4 3/4	4 13/16	1 1/16	1 1/2
	3 Ton WJ/DWJ	6 1/2	3 7/8	1 1/4	.7491 .7479	1 1/4	1.750	2 1/2	2 5/16	11/16	4 3/8	6 5/8	1/8	4 3/8	2 3/8	3/4	4 3/8	8 1/8	4 3/8	5 1/8	3/4	2
	5 Ton WJT/DWJ	8 1/4	5 3/4	1 1/2	.9991 .9979	1 1/2	2.188	3 1/8	2 15/16	13/16	6 3/16	7 3/16	0	5 11/16	1 13/16	1	6 3/16	11 3/16	6 3/16	6 13/16	1 1/2	2 1/2
	10 Ton WJ/DWJ	9	7 1/4	2	1.2488 1.2472	1 1/2	2.598	3	3 1/8	1 1/8	6 1/8	7 1/2	0	6	2 1/2	1 5/16	6 1/8	13 1/8	6 1/8	8 7/8	1 31/32	3
	15 Ton WJ/DWJ	9 1/2	7 1/2	2 1/4	1.4988 1.4972	1 3/4	2.598	3 1/2	3 3/4	1 1/4	7	8 3/8	0	6 7/8	2 5/8	1 5/16	7	13	7	7 11/16	1 31/32	3
	20 Ton WJ/DWJ	11 1/4	8	2 1/4	1.4988 1.4972	1 3/4	2.598	4 1/4	4 1/4	1 1/4	8 1/4	9 5/8	0	8 1/4	2 5/8	1 3/8	8 1/4	14 1/4	8 1/4	8	1 15/16	3
Ball Screw	2 Ton RWB/RHWB	7 1/4	3 1/4	1 1/4	.7491 .7479	1 1/4	1.703	3 1/8	2 5/16	11/16	7	9 7/16	9/16	7	2 9/16	3/4	4 11/16	9 7/16	4 11/16	6 1/16	1 1/8	3 1/8
	5 Ton WB	8 1/4	5 3/4	1 1/2	.9991 .9979	1 1/2	2.188	3 1/8	2 15/16	13/16	9 7/16	12 3/4	11/16	9 7/16	4 3/4	1 1/4	6 3/16	12 3/16	6 3/16	7 1/2	1 1/8	4 1/2
	5 Ton HWB	8 1/4	5 3/4	1 1/2	.9991 .9979	1 1/2	2.188	3 1/8	2 15/16	13/16	9 7/16	12 3/4	11/16	9 7/16	4 3/4	1 1/4	6 3/16	11 5/8	6 3/16	6 15/16	1 1/8	3 25/32
	10 Ton WBL	9	7 1/4	2	1.2488 1.2472	1 1/2	2.598	3	3 1/8	1 1/8	9 9/16	12 3/4	11/16	9 9/16	3	1 1/4	6 1/8	12 3/4	6 1/8	8 7/16	1 3/4	4 1/2
	10 Ton HWBL	9	7 1/4	2	1.2488 1.2472	1 1/2	2.598	3	3 1/8	1 1/8	9 9/16	12 3/4	11/16	9 9/16	3	1 1/4	6 1/8	12 3/16	6 1/8	7 7/8	1 3/4	3 25/32
	10 Ton WB/HWB	9	7 1/4	2	1.2488 1.2472	1 1/2	2.598	3	3 1/8	1 1/8	13 1/8	16 3/8	11/16	13 1/8	3 1/8	1 1/4	6 1/8	15 5/16	6 1/8	10 3/8	2	6 5/8
	20 Ton WB	11 1/4	8	2 1/4	1.4988 1.4972	1 3/4	2.598	4 1/4	4 1/4	1 1/4	15 3/16	19 7/8	3/8	15 3/16	4	1 1/2	8 1/4	18 1/4	8 1/4	12	2 3/4	6 3/4

Trunnion adapters mounted to inverted jacks will decrease the minimum closed dimension and may shorten the travel.

*Contact Joyce/Dayton if multiple trunnion-mounted jacks will be used in a system.

Note: Drawings are artist's conception — not for certification; dimensions are subject to change without notice.

OPTIONS LIMIT SWITCHES

Rugged Joyce limit switches allow you to set precise travel limits and stops on Joyce jacks and actuators. They are also ideal in any application where rotary motion of a machine component can be used to indicate linear motion of another part. They are compatible with 2-ton through 150-ton jacks, actuators, electric cylinders, and integrated actuators.

LS7 Limit Switch

The LS7 Limit Switch has two Single-Pole, Double-Throw (SPDT) switch contacts. This switch offers a NEMA 4 rated enclosure — rated for dust, rain and hose-directed water. To set switches, first remove the cover plate and “L” bracket, then manually rotate the cams to desired positions. This switch is compatible with integrated actuators.

LS8 Limit Switch

The LS8 limit switch is best suited for general-purpose applications requiring up to four switch contacts for operating motors, lights and other accessories. It is available in two models: the LS8 402 (two-switch model) and the LS8 404 (four-switch model). Both LS8 models offer NEMA 4 rated enclosure — rated for dust, rain and hose directed water. Simply loosen a cam detent screw and rotate the switch trip cam to the desired position to achieve switch adjustment.

LS9 Limit Switch

The LS9 limit switch is recommended for general-purpose applications that require two to seven switches. Similar to the LS8 model, the LS9 offers the same high quality NEMA 4 rated enclosure. Five models are available, from the two-switch LS9 502 to the seven-switch LS9 507. Switch adjustment is accomplished with screwdriver adjustment of a self-locking wormgear connected to the switch cam. Switches can be either all SPDT or all DPDT.



LS7



LS8



LS9



Note: Drawings are artist's conception — not for certification; dimensions are subject to change without notice.

OPTIONS LIMIT SWITCHES

Rotation positions shown looking into end of shaft.

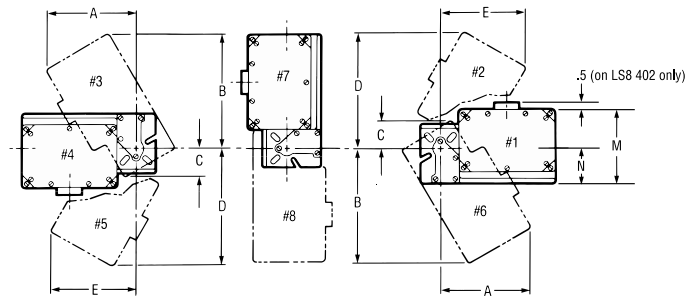

Shaft Detail

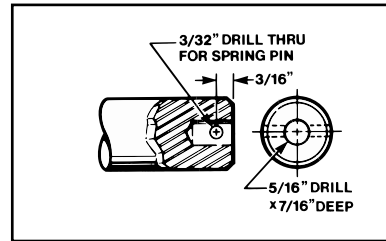

- Machine Screw Jacks (p. 18)
- Machine screw ComDRIVES® (p. 45)
- Stainless Steel Jacks (p. 58)
- Metric Screw Jacks (p. 71)
- Ball Screw Jacks (p. 80)
- BallScrew ComDRIVES (p. 102)
- Electric Cylinders (p. 118)
- Integrated Actuators (p. 135)

2, 3, 5, 10, 15 and 20-ton jacks are available with limit switch positions #1, #3 and #5.
25, 30, 35, 50 and 75-ton jacks are available with limit switch positions #1, #4, #7 and #8.
*Refer to specific product drawing

LEFT SIDE MOUNTING

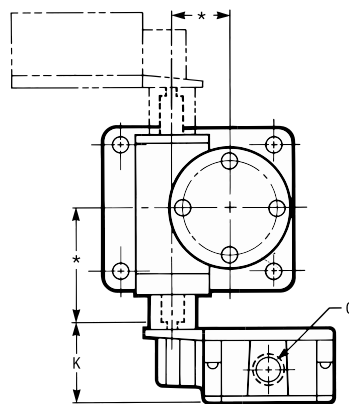

RIGHT SIDE MOUNTING
(ROTATION POS #1 SHOWN)

- Bevel Gear Jacks (p. 148)
- Bevel Ball Actuators (p. 159)

BG and BB are available with all switch positions.

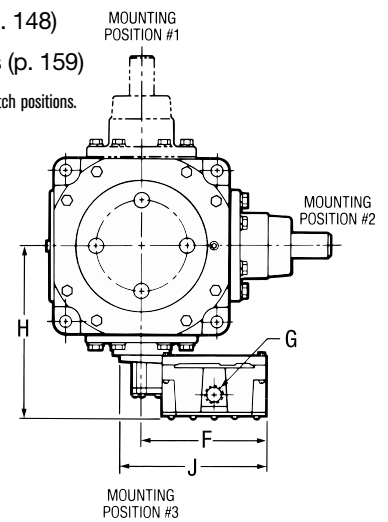

Type	Dimensions														
	A	B	C	D	E	F	G	H BG150 BB150	H BG250 BB225	H BG375 BB300	H BG450 BB400	J	K	M	N
LS7 402	3.81	6.13	1.75	5.44	5.00	5.63	1/2 NPT	7.63	9.00	10.13	15.22	7.0	3.28	3.88	2.63
LS8 402	5.50	6.62	2.00	6.75	5.25	6.25	3/4 NPT	7.88	9.25	10.38	15.47	7.62	3.53	5.25	2.46
LS8 404	6.50	8.38	2.00	8.50	6.25	8.25	1 NPT	8.62	10.00	11.19	16.47	9.62	4.53	5.25	2.46
LS9 502 – 507	6.31	9.25	1.50	8.69	7.25	8.81	1/2 NPT	9.31	10.75	11.88	16.78	10.19	4.84	5.50	3.31

LS8 (400 Series) and LS9 (500 Series) Switch Combination Chart									
Switch Quantity		Single-Pole Double-Throw (SPDT)							
		0	1	2	3	4	5	6	7
D. P. D. T.	0			402/502	503	404/504	505	506	507
	1		402		404				
	2	402/502		404					
	3	503	404						
	4	404/504							
	5	505							

Note: Drawings are artist's conception — not for certification; dimensions are subject to change without notice.

OPTIONS GEARED POTENTIOMETERS

Joyce geared potentiometers are ideal for precise positioning applications. Using a 10-turn potentiometer, a signal is provided as either a change in resistance or current (when supplied with a 4-20 mA instrument transformer), which is proportional to the actual position of the screw. Geared potentiometers are commonly needed when PLCs or computers control jacks.

Geared potentiometers are available on wormgear design jacks of 2-ton to 150-ton capacity. They include a slip clutch to prevent damage due to over-rotation but should always be inspected during installation to ensure that a full range of motion is available throughout the jack travel.

As an additional option, geared potentiometers are available with upper and lower mechanical limit switches. These are common SPDT cam operated switches used for end of travel limits or set points. The standard operating voltage is less than or equal to 48 V (an operating voltage of greater than 48 V is available upon request).

Ordering information is found within specific product sections.

Order Codes		Rating
POTA	0-10 V	IP65
POTB	4-20mA	IP65
POTC	0-10 V with 2 limit switches	IP52*
POTD	4-20mA with 2 limit switches	IP52*

* IP65 available as an option

Geared Potentiometer Electrical Characteristics	
Resistance	10 kΩ
Resistance Tolerance	+/- 5 %
Linearity Tolerance	+/- 0.25%
Load Capacity	2 W at 70°C
Standard Residual End Point Resistance	Greater of 0.2% or 1Ω
Operating Temperature	-20°C to 80°C
Expected Service Life (shaft rev)	2 x 10 ⁶
Housing	Aluminum

Instrument Transformer Characteristics POTB and POTD	
Supply Voltage (+U _B)	24 VDC +/- 20%
Max. Load Impedance (R _B)	<500 Ω
Output Current (I _{MESS})	4-20 mA 24 V DC ±20 %, with load ≤ 500
Operating Temperature	-20°C to 80°C

4-20mA signal increases as screw extends

Jack Capacity	POTA and POTB "A"	POTC and POTD "A"
2 Ton	6 3/8	8 1/4
2.5 Ton	6 1/4	8
3 Ton	6 1/4	8
5 Ton	7	8 7/8
10 Ton	7 7/8	9 7/8
15 Ton	7 7/8	9 7/8
20 Ton	8 1/4	10 1/4
25 Ton	9	10 7/8
30 Ton	9	10 7/8
35 Ton	9	10 7/8
50 Ton	10 7/8	12 3/4
75 Ton	12 1/4	14 1/8
100 Ton	12 1/4	14 1/8
150 Ton	12 1/4	14 1/8

Geared Potentiometer: Connection Diagrams

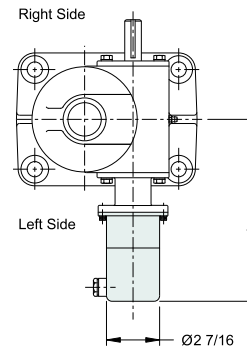
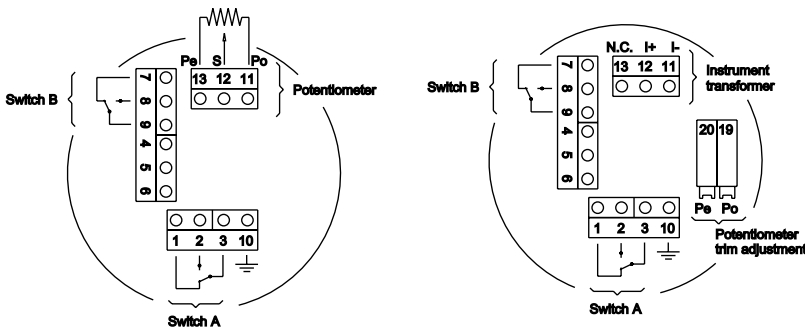

Instrument Transformer: Connection Examples

Load against ground

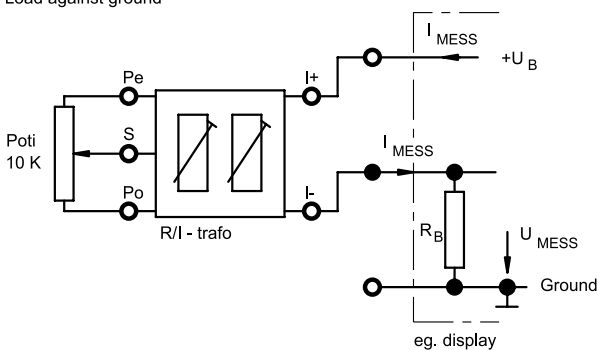

$$U_{MESS} = R_B \times I_{MESS}$$

Load against +

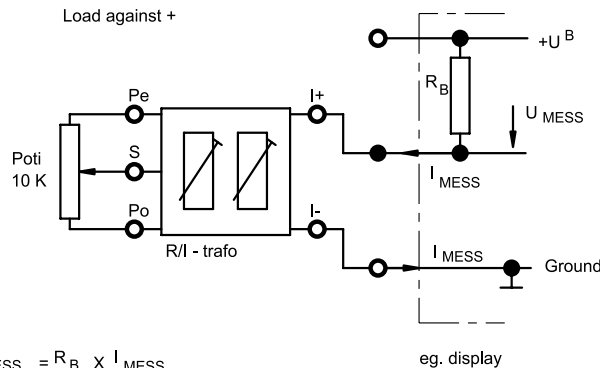

Note: Drawings are artist's conception — not for certification; dimensions are subject to change without notice.

OPTIONS HAND WHEELS AND COUNTERS

Hand Wheel Dimensions						
Jack Capacity	Dimension	4" Diameter HW04	6" Diameter HW06	8" Diameter HW08	10" Diameter HW10	12" Diameter HW12
250, 500 Lb. and 1,000 Lb.	A	4 5/8	6 1/8			
	B	1	2			
	C	3/8	3/4			
1 Ton	A	5 3/8	6 7/8	7 5/8	8 1/2	8 7/8
	B	1/2	1 1/2	2 1/2	3 1/2	4 1/2
	C	5/8	1	1 3/8	1 7/8	2 1/4
2 Ton Standard Base	A	5 7/8	7 1/4	8	9	9 1/4
	B	1/4	1 1/4	2 1/4	3 1/4	4 1/4
	C	0	3/8	3/4	1 1/4	1 5/8
2 Ton Reverse Base	A	5 3/4	7 1/4	8	9	9 1/4
	B	1/4	1 1/4	2 1/4	3 1/4	4 1/4
	C	1 3/4	2 1/8	2 1/2	3	3 3/8
2.5 Ton	A	5 3/4	7 1/4	8	9	9 1/4
	B	1/4	1 1/4	2 1/4	3 1/4	4 1/4
	C	1 1/2	1 7/8	2 1/4	2 3/4	3 1/8
3 Ton	A	5 3/4	7 1/4	8	9	9 1/4
	B	1/4	1 1/4	2 1/4	3 1/4	4 1/4
	C	1 1/2	1 7/8	2 1/4	2 3/4	3 1/8
5 Ton	A	6 3/8	7 3/4	8 3/4	9 1/2	10
	B	0	3/4	1 3/4	2 3/4	3 3/4
	C	1 1/8	1 1/2	1 7/8	2 3/8	2 3/4
10 Ton	A			9 3/8	10 1/4	10 5/8
	B			1 3/4	2 3/4	3 3/4
	C			1 7/8	2 3/8	2 3/4
15 Ton	A			9 3/8	10 1/4	10 5/8
	B			1 1/4	2 1/4	3 1/4
	C			1 3/4	2 1/4	2 5/8
20 Ton	A			9 3/8	10 1/4	10 5/8
	B			3/4	1 3/4	2 3/4
	C			1 1/2	2	2 3/8

Hand wheels are recommended for self-locking jacks. They are aluminum.

Counter Dimensions							
Dimension	Jack Capacity						
	2 Ton	2.5 Ton	3 Ton	5 Ton	10 Ton	15 Ton	20 Ton
D	4 1/2	4 1/2	4 1/2	5	5 7/8	5 7/8	6

Standard count increases as lifting screw extends. Longer wormshafts are available, contact Joyce/Dayton.

Ordering information is found within specific product sections.

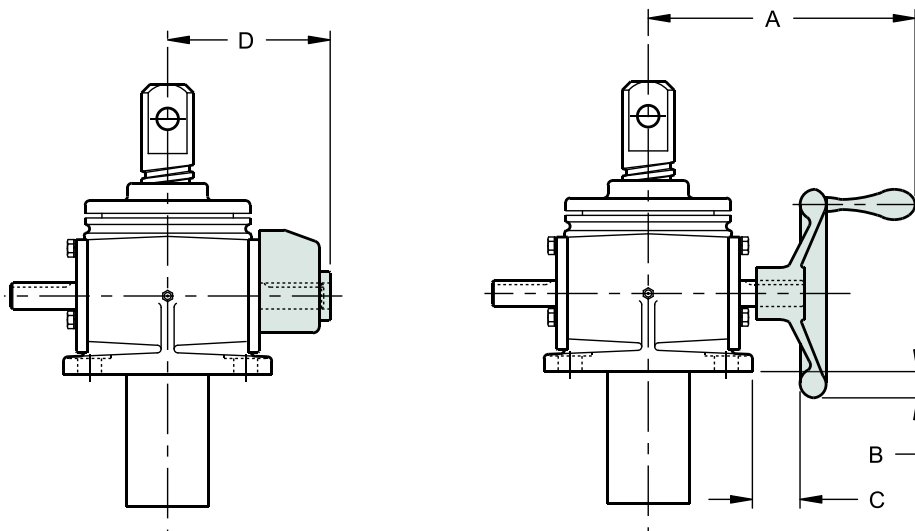

Note: Drawings are artist's conception — not for certification; dimensions are subject to change without notice.

Precise Position Sensing

Joyce can equip machine screw jack models between 2-ton and 150-ton capacity, and electric cylinders with an encoder to allow accurate position sensing within increments of 0.001 inches. The encoder combines with your control system to monitor screw travel, number of revolutions, and travel limits.

Joyce's shaft-mounted encoder offers easy installation, proven reliability and virtually maintenance-free operation. It includes a six-pin electrical connector, worm shaft coupling, and mounting adapter. Standard encoders are 200 pulses per revolution.

Mating connector cables can be purchased separately. Contact Joyce/Dayton for more information.

6-Pin Connector

For open connector and pull-up resistor units, Pin A and Pin F are tied together. Either pin may be used for common.

- A** Power supply and output common
- B** + Volts DC
- C** Open
- D** Output A
- E** Output B
- F** Power supply and output common

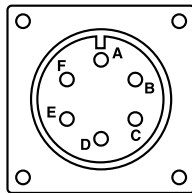

Note: Ring encoders are also available. Contact Joyce/Dayton with your requirements. Complete ordering information is available within the product sections.

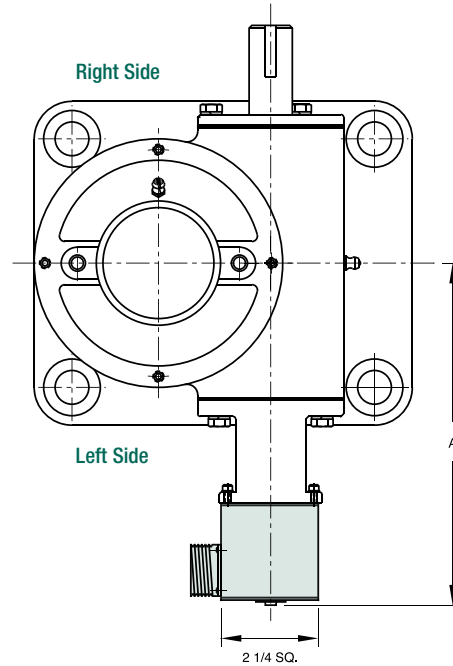

Dimensions	
Capacity	A
2 Ton	5.84
2.5 Ton	6.88
3 Ton	6.88
5 Ton	6.88
10 Ton	7.94
15 Ton	7.94
20 Ton	8.31
25 Ton	8.88
30 Ton	8.88
35 Ton	8.88
50 Ton	10.94
75 Ton	12.13
100 Ton	12.19
150 Ton	12.19

Encoder Specifications	
Speed Range	0-1750 rpm
Voltage	12 Volts DC
Current	60 mA–115 mA
Output Drive	250 mA/channel continuous
Maximum Load	50 ohms per channel

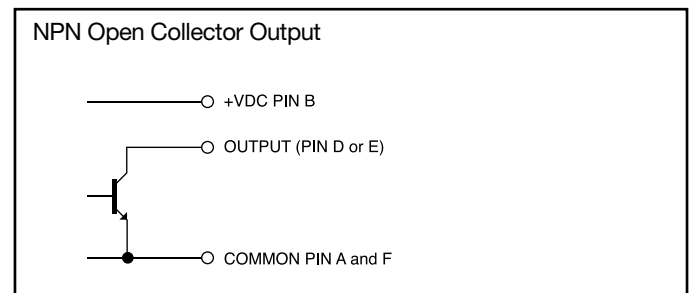
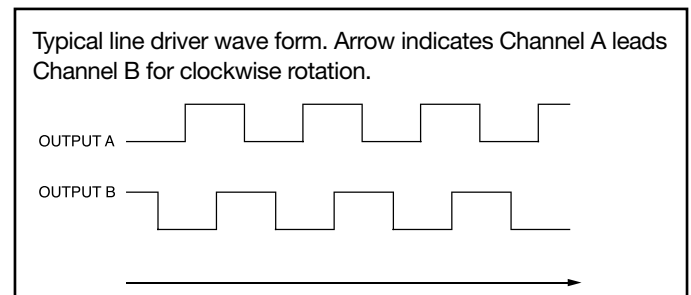

Note: Drawings are artist's conception — not for certification; dimensions are subject to change without notice.

Finishes for Jack Housings

- Gray enamel is the standard finish for Joyce jacks (2-ton and larger), actuators, electric cylinders, and integrated actuators.
- Miniature jacks with aluminum housings (WJ250, WJ500, WJ1000, WJ51, WJ201, WBL51, WB51, WBL201, & WB201) are unpainted.
- Standard epoxy (F2) is comprised of a two-component polyamide primer, and a two-component, low VOC, polyurethane topcoat (available in green and white).
- STEEL IT epoxy finish provides a hard, non-toxic finish. It is comprised of a two-part, lead-free epoxy primer with a two-part polyamide epoxy topcoat (which incorporates 316 stainless steel leafing pigment). Approved by USDA for use where incidental food contact may occur.
- Joyce outdoor paint process (F3), is an exclusive paint process that protects against corrosion due to harsh outdoor environments. It incorporates rigorous surface preparation with a premium epoxy primer and topcoat and stainless steel hardware resulting in a durable, corrosion-resistant finish that is in high demand on antenna jacks, solar actuators, mining industry jacks and jacks used in coastal installations.
- Clear coat anodizing is a uniform coating process that increases the corrosion resistance and wear properties of aluminum housings. It will not flake or peel.
- Electroless nickel plating is a thin, uniform coating. When applied to jack housings, it provides superior corrosion resistance and improved wear resistance, while having little effect on the fit of mating components.

Material and Finishes for Lifting Screws

- Stainless steel lifting screws are standard on WJ500, WJ1000, and for all stainless steel jacks. They are available for machine screw jacks, bevel gear jacks, metric jacks, and traveling nut (TN) style integrated actuators.
- Armoloy®, a thin, dense chrome finish, increases resistance to wear and corrosion, and improves lubricity. It can also be applied to stainless steel components for superior corrosion resistance. This thin coating (0.0001" — 0.0003") has little effect on the fit of mating components.
- Xylan® coating, which uses a combination of fluoropolymer lubricants and resin binders, significantly reduces the coefficient of friction of components and offers excellent corrosion protection and good chemical resistance. The application of this coating (0.0002" — 0.0007") has little effect on the fit of mating parts.

Finishes for Input Shafts, Clevis Ends, and Other Components

- Stainless steel worm shafts, standard on WJ250, WJ500, WJ1000, and all stainless steel jacks, are available as an option on most wormgear style jacks.
- Armoloy, a thin, dense chrome finish increases wear and corrosion resistance, and improves lubricity. It can also be applied to stainless steel components for superior corrosion resistance. This thin coating (0.0001" — 0.0003") has little effect on the fit of mating components.
- Electroless nickel plating is a thin, uniform coating. When applied to worm and pinion input shafts, it provides superior corrosion resistance and improved wear resistance, while having little effect on the fit of mating components.
- Zinc coating provides protection against corrosion, increases surface lubricity, and improves the aesthetic appearance of components. The effect it has on the fit of mating components is dependent on the thickness of its application (0.0002" — 0.0010").



Standard Enamel Finish



STEEL IT Epoxy



Standard Epoxy



Electroless Nickel Finish

To order special finishes and materials, contact Joyce/Dayton.

What are anti-backlash devices?

Anti-backlash devices are internal jack components used to minimize backlash (free movement between the lifting screw and nut) in machine screw jacks.

Why are anti-backlash devices needed?

Anti-backlash devices are typically used in reversing load applications where the lifting screw position is critical.

How many anti-backlash devices do you offer and how do they work?

Joyce/Dayton offers three unique anti-backlash designs, each use the same concept of clamping two independent nut halves against the lifting screw threads. Contact Joyce/Dayton to determine the best anti-backlash design for your requirements.

Where are anti-backlash devices used?

Anti-backlash devices are frequently used in steel mill applications where the screw jacks are used to set and maintain the position of the movable upper roll of a rolling mill. In operation, the initial weight of the roll pulls the lifting screw to one side of the nut. When steel passes through the rolls, the load reverses on the lifting screw and movement in the opposite direction is limited by the anti-backlash device. Other common applications include screw jacks used to position communication antennas and solar panels. In these applications, directional changes in the wind can buffet the panels thus affecting the position of the lifting screw. During these high wind conditions, anti-backlash devices minimize the lifting screw movement.

Will the anti-backlash device require adjustment?

When the internal nut threads begin to wear, lifting screw backlash increases. Subsequent adjustment of the anti-backlash device compensates for the nut wear and allows the user to limit the backlash to the recommended value. Adjustment frequency will vary depending on load, duty cycle, and temperature. The anti-backlash device should be replaced when no further adjustment is possible due to thread wear.

What effect do anti-backlash devices have on torque requirements?

Torque requirements for screw jack operation are affected by the clearance between the lifting screw and nut thread. Adjusting anti-backlash devices (within recommended values for each design) will not increase the torque to move a given load. If the backlash is set below the recommended values, torque values will increase significantly and thread wear will accelerate.

Can anti-backlash devices be used on ball screw jacks and bevel ball actuators?

No. Rather, the use of oversized ball bearings in ball nut assemblies is recommended to reduce endplay in ball screw jacks and bevel ball actuators. Contact Joyce/Dayton for more information.

OPTIONS ANTI-BACKLASH DESIGNS

A-Split Gear Design

- Best suited for light dynamic loads (1/3 jack capacity or less) and full jack capacity for static loads.
- A split gear and dowel pins maintain gear alignment.
- Adjustments are made by tightening the sleeve (housing) cap.
- Typically reduces endplay to 0.010" – 0.015" without increased torque.*
- Available on Translating and KFTN models, 500-pound to 75-ton (upright and inverted).
- Available on some keyed models. Contact Joyce/Dayton.
- Order using an "A" designation in the suffix of the part number.

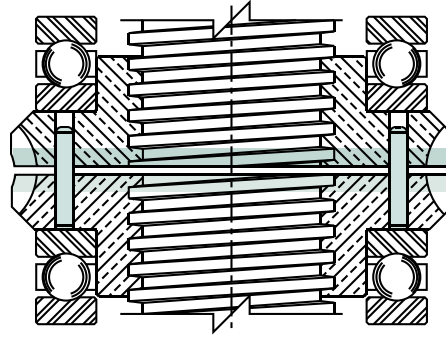

A90 Design

- Best suited for medium dynamic loads (1/2 to 3/4 jack capacity) and full jack capacity for static loads.
- This design incorporates a hardened steel plate pinned to the top of the internal gear and a secondary nut placed above the steel plate. Setting the backlash is accomplished by tightening the dog point set screws located inside the secondary nut. The set screws are externally adjustable.
- Typically reduces endplay to 0.008" – 0.012" without increased torque.*
- Available on upright translating models, 25-ton to 100-ton.
- Order using an "A90" designation in the suffix of the part number.

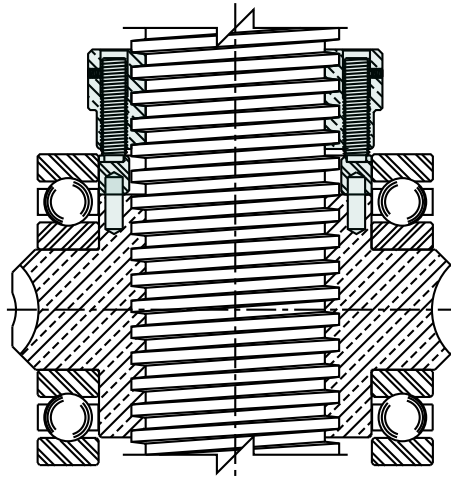

A95 Design

- Capable of handling full jack capacity in dynamic as well as static conditions.
- This design allows the gear teeth to remain intact and therefore retain their full load carrying capacity.
- Adjust endplay by tightening the sleeve (housing) cap.
- Typically reduces endplay to 0.008" – 0.012" without increased torque.*
- Available on upright and inverted translating models, 2-ton to 150-ton.
- Order using an "A95" designation in the suffix of the part number.

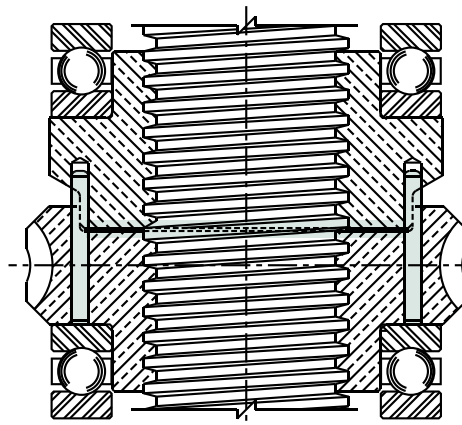

*If the backlash is set below the recommended values, torque values will increase significantly and thread wear will accelerate. **Ordering information is found within specific product sections.**

ACCESSORIES MITER GEAR BOXES

Joyce miter gear boxes are specifically engineered for use with Joyce jacks and actuators in multiple jacks systems. Miter gear boxes used in such systems effectively raise unevenly distributed loads. When driven shaft turns per inch of travel are the same, total synchronization is assured because all models have a uniform lifting speed. Arrows in assembly drawings below indicate shaft rotation.

All standard Joyce miter gear boxes are 1:1 ratio, other ratios are available in the RC series units. Four-shaft units are also available in the RC-18 through RC-204 and the MK series.



RC-6, RC-9 and RC-12



RC-15 through RC-204



MK Series

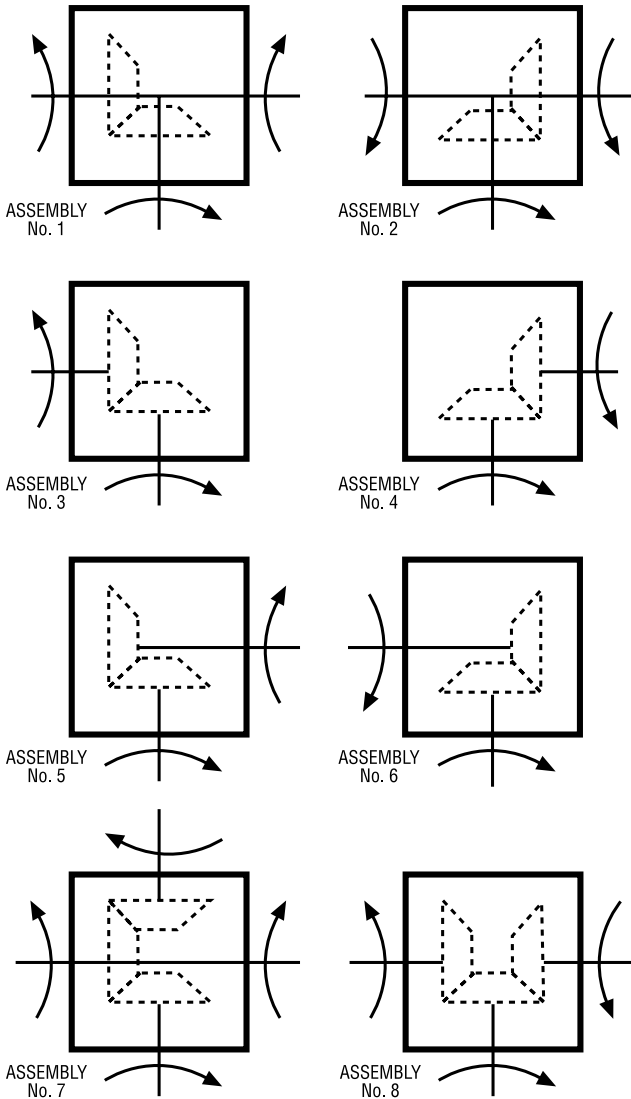

Assembly No. 7 and 8 availability:

- RC-18 RC-38
- RC-99 RC-204
- MKA

Note: Drawings are artist's conception — not for certification; dimensions are subject to change without notice.
When ordering miter gear boxes specify model numbers and assembly numbers.

ACCESSORIES MITER GEAR BOXES

RC-6 THROUGH RC-12

Lubrication

Units are lifetime lubricated.

RC-6 shafts feature flats (shown below).

RC-9 and RC-12 models have keyways.

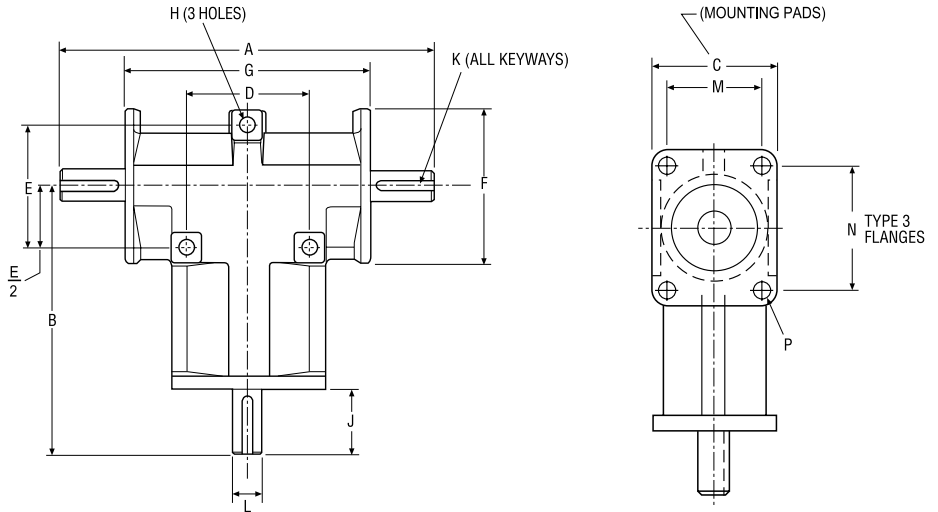
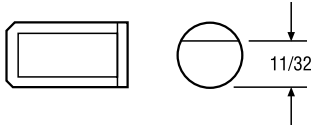

Model No.	Maximum Torque Rating* (In. Lbs.)	Max. HP	Max. RPM	A	B	C	D	E	F	G	H	J	K	L	M	N	P	Approx. Wt. (Lbs.)
RC-6	36	0.21	5,000	4 5/16	2 15/16	1 1/4	1 5/16	1 5/16	1 5/8	2 3/4	7/32	25/32		3/8	7/8	1 3/16	3/16	3/4
RC-9	130	0.75	5,000	7 3/8	4 13/16	2	1 7/8	1 7/8	2 1/2	4 1/4	9/32	1 9/16	3/16 x 1 3/8	5/8	1 3/8	1 7/8	9/32	3
RC-12	382	2.17	5,000	9 1/8	6 9/16	3	3	3	3 7/8	6	3/8	1 9/16	3/16 x 1 3/8	3/4	2 1/4	3	3/8	8

* Torque @ 100 RPM and 750 hours of life.

RC-15

Lubrication

Fill with 6 ounces. EP-90 gear oil for normal operation. Units are shipped less lubricant.

Dimensions are representative of 1:1 ratio miter boxes.

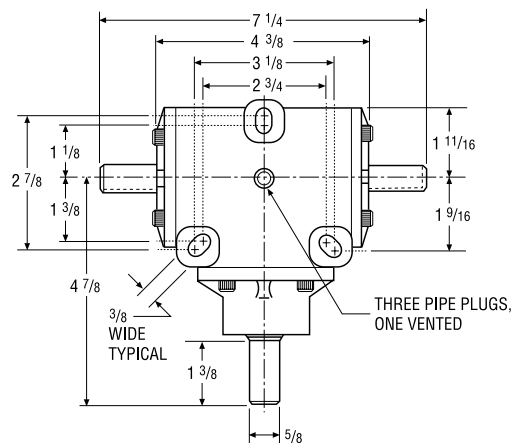
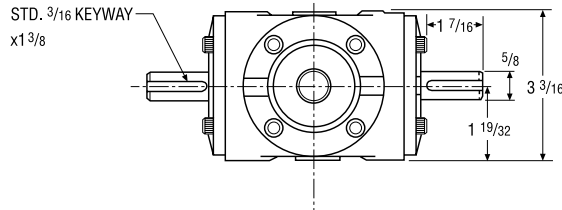

Model No.	Maximum Torque Rating* (In. Lbs.)	Max. HP	Max. RPM	Approx. Wt. (Lbs.)
RC-15	498	3.16	2,800	5

* Torque @ 100 RPM and 750 hours of life.

Note: Drawings are artist's conception — not for certification; dimensions are subject to change without notice.

ACCESSORIES MITER GEAR BOXES

RC-18 THROUGH RC-204

Lubrication

Units shipped less lubricant.
Fill with EP-90 gear oil

Model RC-18	1 pint
Model RC-38	1 1/2 pints
Model RC-99	4 1/2 pints
Model RC-204	8 pints

Dimensions are representative
of 1:1 ratio miter boxes.

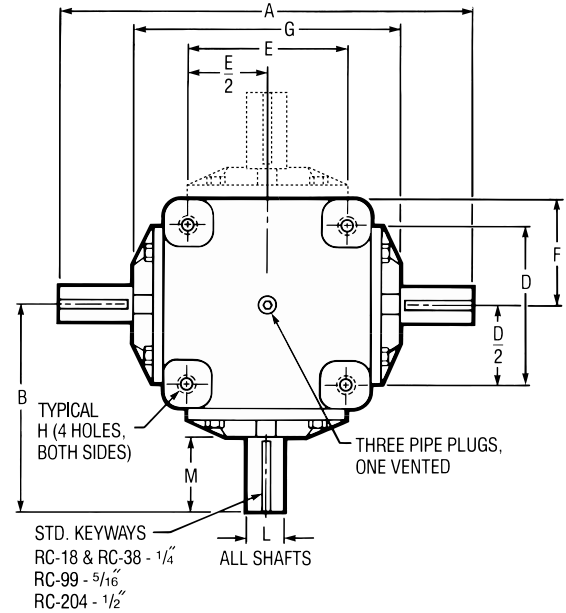
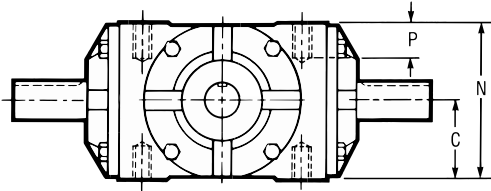

Model No.	Maximum Torque Rating* (In. Lbs.)	Max. HP@ 400 RPM	Max. RPM	Gears	A	B	C	D	E	F	G	H	L	M	N	P	Approx. Wt. (Lbs.)
RC-18	1,803	11.53	1800	Precision Forged	11	5 1/2	2 1/16	4 1/4	4 1/4	2 3/4	7	3/8-16	.9995 .9980	2	4 1/8	11/16	26
RC-38	3,873	26.30	1400	Precision Forged	13	6 1/2	2 13/16	4 1/2	4 1/2	2 7/8	8	1/2-13	1.2495 1.2480	2 1/2	5 5/8	7/8	39
RC-99	9,927	72.54	1000	Precision Forged	16 1/2	8 1/4	3 3/4	6	6	4 1/8	10 5/8	1/2-13	1.3745 1.3730	2 15/16	7 1/2	1 3/8	72
RC-204	20,400	181.75	800	Precision Forged	19	9 1/2	4 3/4	8	8	4 15/16	13	5/8-11	1.9995 1.9980	3	9 1/2	1 1/4	172

*Torque @ 100 RPM and 750 hours of life.

MK SERIES

Lubrication

Units shipped less lubricant.
Fill with EP-90 gear oil.

Model MKA	1 1/4 pints
-----------	-------------

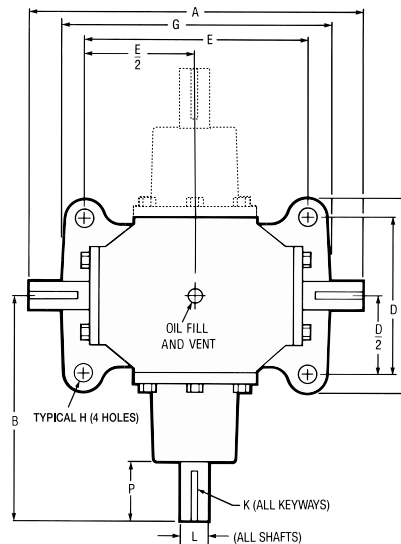
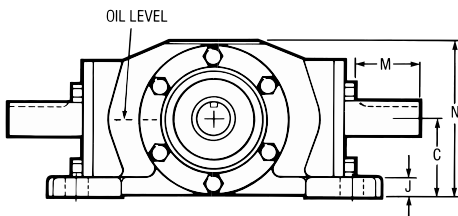

Model No.	Maximum Torque Rating (In. Lbs.)	A	B	C	D	E	F	G	H	J	K	L	M	N	P	Approx. Wt. (Lbs.)
MKA	3,000	12	8	2 1/4	5 1/2	8	6 7/8	9 9/16	11/16	1/2	1/4 x 1/8 x 1 1/2	1.0005 .9995	1 31/32	4 9/16	2 1/8	33

Note: Drawings are artist's conception — not for certification; dimensions are subject to change without notice.

OPTIONS MOTOR MOUNTS AND STOCK MOTORS

Joyce Motor mounts allow direct coupling to the motor shaft on either the right (shown) or left side jack input shaft. For easy installation 2-ton through 20-ton wormgear style jacks are available with motor mount adapters for standard NEMA C-Face motors. Jacks supplied with motor mounts are available with and without NEMA C-Faced motors. When motors are included they come with the necessary hardware and coupling keys. Contact Joyce/Dayton for information about other types of motor mounts (i.e., IEC, pneumatic, servo motor, etc.).

Motor Mount Dimensions			
Capacity	NEMA Frame Size	A	B
2 ton	56C	6.25	.50
	140TC		
2.5 ton	56C	6.25	.50
	140TC		
3 ton	56C	6.25	.50
	140TC		
5 ton	56C	7.25	.50
	140TC	7.25	.50
	180TC	8.00	.63
10 ton	56C	8.25	.50
	140TC	8.25	.50
	180TC	9.00	.63
15 ton	56C	8.25	.50
	140TC	8.25	.50
	180TC	9.00	.63
20 ton	56C	8.25	.50
	140TC	8.25	.50
	180TC	9.00	.63
	210TC	9.75	.88

Motor Dimensions					
HP	NEMA Frame Size	C	D	E	F
1/3	56C	7.06	9.31	5.94	4.25
1/2	56C	7.06	9.31	5.94	4.25
3/4	56C	7.06	9.31	5.94	4.25
1	143TC	7.19	10.25	6.34	4.56
1 1/2	145TC	7.19	10.25	6.34	4.56
2	145TC	7.19	11.25	6.34	4.56
3	182TC	9.06	17.38	7.50	4.56
5	184TC	9.06	18.75	7.50	4.56
7 1/2	213TC	10.85	15.81	7.50	8.25

Ordering information is found within specific product sections.

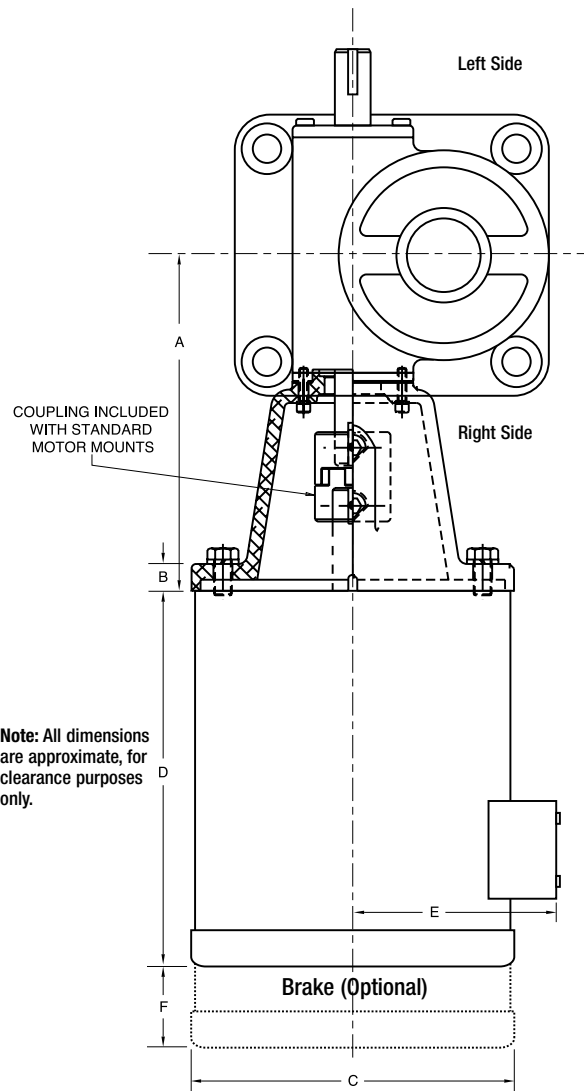

Note: All dimensions are approximate, for clearance purposes only.

- All standard motors are 3-phase, 60 Hz., 208-230/460 VAC or 230/460 VAC. Other motor options are available. Maximum 1750 RPM input.
- It is important to consider the input torque a direct drive motor must deliver at start up.
- Brake motors (M2) are recommended for double lead jacks, ball screw jacks and actuators, and electric cylinders that are more than 30% efficient.
- If the motor frequency will be varied to provide a “soft” start, an inverter duty motor may be needed.

NOTE: JAX® software may not accurately calculate horsepower required for systems having direct drive motors. Contact Joyce/Dayton for assistance.

Note: Drawings are artist's conception — not for certification; dimensions are subject to change without notice.

ACCESSORIES PILLOW BLOCKS

Joyce ductile iron pillow blocks include self-aligning replaceable bearings that are pre-lubricated with lithium grease. They include steel retainers, and nitrile rubber seals with steel guards. Pillow block supports are suitable for shaft supports and bearing supports for rotary screws on keyed for traveling nut jacks under normal duty operation. Contact Joyce/Dayton technical support for your specific application.

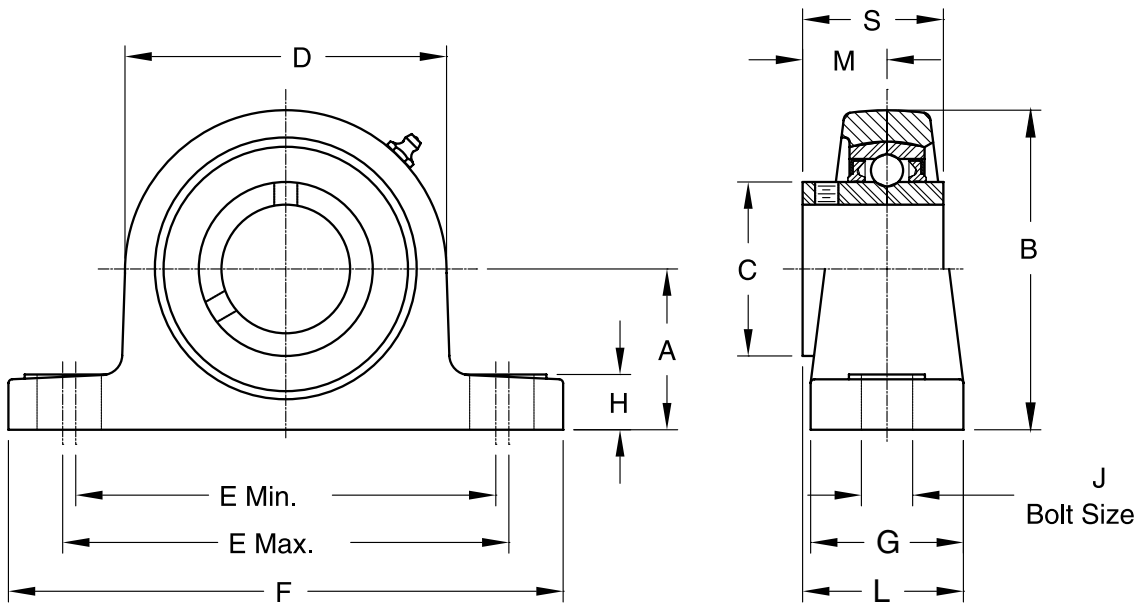

2 Bolt Pillow Blocks - Ductile Iron Housing - For Low Shaft Height - Setscrew Lock - Wide Inner Ring															
Part Number	Shaft Size	A	B	C	D	E Min.	E Max.	F	G	H	J	L	M	S	Wt. Lbs.
PB-050	1/2	1 1/16	2 1/8	0.969	2 1/4	3 3/8	3 5/8	4 3/4	1 3/8	33/64	3/8	1 5/16	0.626	1.079	1.2
PB-063	5/8														
PB-075	3/4	1 1/4	2 1/2	1.142	2 5/8	3 3/4	3 31/32	5 1/32	1 1/2	35/64	3/8	1 15/32	0.720	1.220	1.9
PB-100	1	1 5/16	2 5/8	1.339	2 25/32	4	4 1/4	5 1/2	1 9/16	19/32	3/8	1 9/16	0.776	1.339	2.4
PB-125	1 1/4	1 13/16	3 19/32	1.843	3 27/32	4 13/16	5 3/16	6 9/16	1 7/8	45/64	1/2	1 15/16	1.000	1.689	3.8
PB-144	1 7/16														
PB-150	1 1/2	1 15/16	3 27/32	2.063	4 3/16	5 5/16	5 11/16	7 1/8	2 1/16	3/4	1/2	2 7/32	1.189	1.937	4.8
PB-169	1 11/16	2 1/16	4 1/8	2.260	4 17/32	5 9/16	5 15/16	7 7/16	2 1/8	25/32	1/2	2 1/4	1.189	1.937	5.4
PB-175	1 3/4														
PB-200	2	2 7/16	4 27/32	2.705	5 5/16	6 7/8	7 3/8	9 1/8	2 3/8	29/32	5/8	2 1/2	1.315	2.189	8.7

Note: Drawings are artist's conception — not for certification; dimensions are subject to change without notice.

ACCESSORIES FLANGE BLOCKS

Joyce ductile iron flange blocks include self-aligning replaceable bearings that are pre-lubricated with lithium grease. They include steel retainers, and nitrile rubber seals with steel guards. Flange block supports are suitable for shaft supports and bearing supports for rotary screws on keyed for traveling nut jacks under normal duty operation. Contact Joyce/Dayton technical support for your specific application.

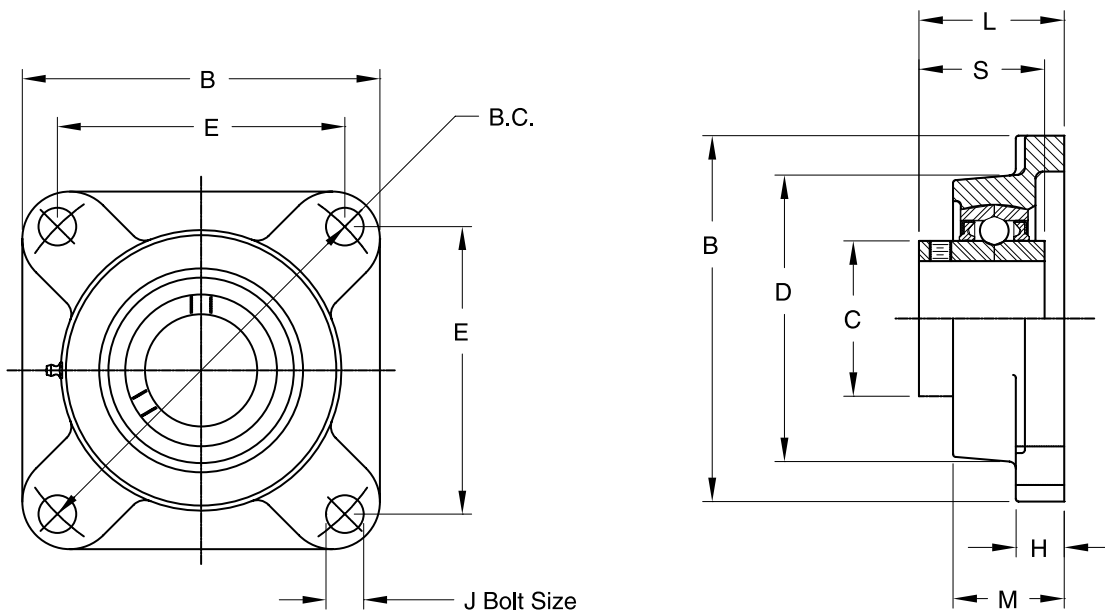

4 Bolt Flange Blocks - Ductile Iron Housing - Setscrew Lock - Wide Inner Ring												
Part Number	Shaft Size	B	B.C.	C	D	E	H	J	L	M	S	Wt. Lbs.
FB-050	1/2	3	3	.969	2 3/32	2 1/8	7/16	3/8	1 7/32	31/32	1.079	1.0
FB-063	5/8											
FB-075	3/4	3 3/8	3 5/8	1.142	2 3/8	2 1/2	19/32	3/8	1 15/32	1 5/32	1.220	1.5
FB-088	7/8	3 21/32	3 57/64	1.339	2 3/4	2 3/4	19/32	7/16	1 17/32	1 3/16	1.339	1.9
FB-100	1											
FB-125	1 1/4	4 9/16	5 1/8	1.843	3 9/16	3 5/8	11/16	1/2	1 27/32	1 3/8	1.689	4.4
FB-144	1 7/16											
FB-150	1 1/2	5 3/32	5 43/64	2.063	4 1/32	4	11/16	1/2	2 1/8	1 17/32	1.937	5.6
FB-175	1 3/4	5 5/16	5 27/32	2.260	4 1/4	4 1/8	23/32	1/2	2 1/8	1 9/16	1.937	6.0

Note: Drawings are artist's conception — not for certification; dimensions are subject to change without notice.

ACCESSORIES FLEXIBLE COUPLINGS

Joyce Model S and Model F geared couplings offer greater torque capacity than jaw couplings. More gear teeth around the inner circumference of the coupling, plus high torsional, radial and angular stiffness mean that you get a more durable coupling.

Joyce Model S sleeve-type gear couplings are available in flex/rigid and flex/flex configurations.

Model F flange-type gear couplings offer superior radial-misalignment capability and radial flexibility.

Model J jaw-type couplings are ideal for many general industrial applications, require no lubrication and are resistant to oil, grease, moisture and other contaminants.



Model S Coupling

Specifying Information

When specifying hub sizes, please refer to the table to determine the three digit code. The first digit is the whole number of inches in shaft diameter, while the next two digits give the decimal equivalents of fractional inches.

1 63 = 1 5/8" dia. bore
 shaft shaft
 diameter diameter
 in inches decimal

Fraction	Dec. Code	Fraction	Dec. Code
0	00	1/2	50
1/16	06	9/16	56
1/8	13	5/8	63
3/16	19	11/16	69
1/4	25	3/4	75
5/16	31	13/16	81
3/8	38	7/8	88
7/16	44	15/16	94

Ordering Information — Order must indicate coupling size, coupling type (S = sleeve; F = flange; J = jaw), large diameter hub code, hub type (F = flex; R = rigid), small diameter hub code, hub type (F or R), and fit type (S = slip; I = interference).

Example: for sleeve and flange type

10	S	163	F	125	F	S
coupling size	coupling type	large diameter hub code	hub type	small diameter hub code	hub type	fit type

Example: for jaw type

09	J	100	88
coupling size	coupling type	large diameter hub code	small diameter hub code

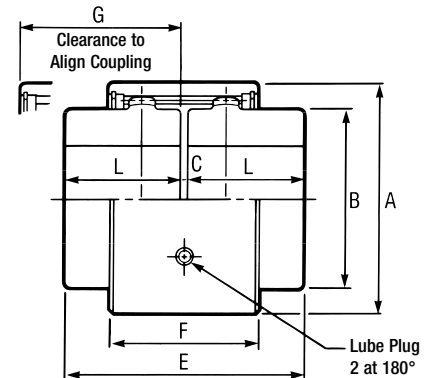

Model S Sleeve-Type

Size	Max. Bore (In.)	Load Capacity		Max. (RPM x 10 ³)	Parallel Offset Capacity (In.)	Lube Capacity			Dimension — Inch							Wt. Solid Hubs (Lbs.)	WR ² Solid Hubs (Lb. In. ²)
		HP/100 (RPM)	Torque (In. Lbs. x 10 ³)			Grease		Oil Volume	A	B	L	C	E	F	G		
						Weight	Volume										
6S	1 1/16	4.5	2.84	19.0	.009	3/32 oz.	.006 pt.	.002 pt.	2 3/8	1 9/16	1 3/16	3/32	2 15/32	1 13/32	1 1/2	2.0	.86
8S	1 5/16	7.0	4.41	16.0	.009	5/16 oz.	.019 pt.	.006 pt.	2 13/16	1 31/32	1 13/32	3/32	2 29/32	1 13/32	1 1/2	3.3	2.4
10S	1 5/8	15.5	9.77	12.6	.015	11/32 oz.	.020 pt.	.006 pt.	3 9/16	2 3/8	1 9/16	3/32	3 7/32	1 27/32	1 7/8	6.1	8.1
12S	1 15/16	22	13.9	11.5	.015	3/8 oz.	.022 pt.	.007 pt.	3 15/16	2 25/32	1 25/32	3/32	3 21/32	1 27/32	1 15/16	8.7	13.5
15S	2	31	19.5	11.0	.039	7/8 oz.	1/16 pt.	1/64 pt.	4 1/8	2 15/16	1 15/16	1/8	4	2 25/32	2 29/32	11.5	21.1
20S	2 5/8	51	32.1	8.8	.045	1 5/8 oz.	1/8 pt.	1/32 pt.	5 1/8	3 3/4	2 7/16	1/8	5	3 3/16	3 5/16	21.5	60.8

- Notes: 1. Load capacities listed are the ratings based on full 1° misalignment per gear mesh.
 2. Maximum bore listed are based on using a square key.
 3. Speeds shown are without dynamic balancing.
 4. Slip fit is standard.

Note: Drawings are artist's conception — not for certification; dimensions are subject to change without notice.

ACCESSORIES FLEXIBLE COUPLINGS



Model F Coupling

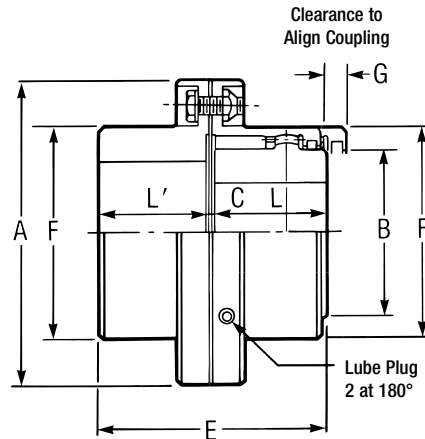

Model F Flange-Type																		
Size	Max. Bore (In.)		Load Capacity		Max. (RPM x 10 ³)	Lube Capacity			Dimension — Inch							Wt. Solid Hubs (Lbs.)	WR ² Solid Hubs (Lb. In. ²)	
	Flex. Half	Rigid Half	HP/100 (RPM)	Torque (In. Lbs. x 10 ³)		Grease		Oil Volume	A	B	L	L'	C	E	F			G
						Weight	Volume											
10F	1 5/8	2 1/8	15.5	9.77	6.5	.6 oz.	1/32 pt.	1/64 pt.	4 9/16	2 27/64	1 11/16	1 9/16	3/16	3 7/16	3 7/64	7/16	9.4	18.2
15F	2	2 3/4	31	19.5	5.3	1 1/8 oz.	1/16 pt.	1/32 pt.	6	2 15/16	1 15/16	1 27/32	5/32	3 15/16	3 29/32	13/32	18.8	66
20F	2 5/8	3 3/8	51	32.1	5.0	2 1/2 oz.	1/8 pt.	1/16 pt.	7	3 3/4	2 7/16	2 9/32	5/32	4 7/8	4 7/8	1/2	31.4	142

- Notes: 1. Load capacities listed are the ratings based on full 1° misalignment per gear mesh.
 2. Shrouded bolt designs are standard, but exposed will be furnished upon request.
 3. Maximum bore listed are based on using a square key.
 4. Speeds shown are without dynamic balancing.
 5. Slip fit is standard.

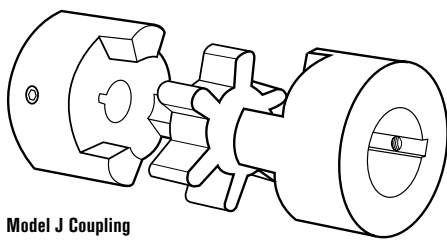

Model J Coupling

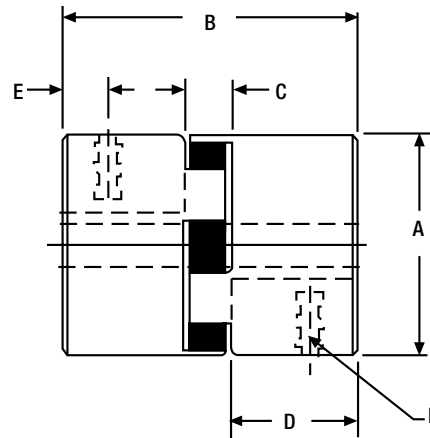

Model J Jaw-Type										
Size	Max. Bore (In.)	Load Capacity Torque (In. Lbs.)	Dimension — Inch						Wt. Solid Hubs (Lbs.)	WR ² Solid Hubs (Lb. In. ²)
			A	B	C	D	E	F		
03J	.375	3.5	.62	.81	.27	.27	.13	#6-32	.1	.003
05J	.563	26.3	1.08	1.72	.48	.62	.31	1/4-20	.3	.054
07J	.750	43.2	1.36	2.00	.50	.75	.38	1/4-20	.6	.115
08J	.875	90.0	1.75	2.12	.50	.81	.31	1/4-20	1.0	.388
09J	1.000	144.0	2.11	2.12	.50	.81	.44	1/4-20	1.5	.772

Note: Torque values based on nitrile insert, other insert material available upon request.

Note: Drawings are artist's conception — not for certification; dimensions are subject to change without notice.

ACCESSORIES SHAFTING

Joyce shafting matches perfectly with Joyce jacks and couplings to meet a wide range of system requirements. Shafting is made from cold-finished 1018 steel, with ends machined to ANSI-standard keyways. For further information on common jack system arrangements, refer to page 195.

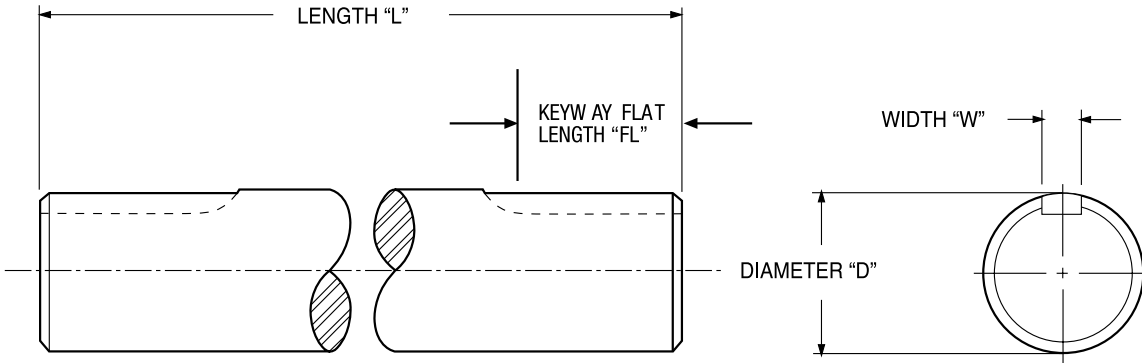

Dimensions and Minimum Shaft Length		S50	S63	S75	S88	S100	S113	S125	S138	S150	S163	S175	S188	S200	S213	S225	S238	S250	S262
Minimum Shaft Length* "L"	Flange	7	7	7	7	7	7	7	7	7	7	7	8	8	10	10	10	10	10
	Sleeve	5	5	5	5	5	6	6	6	7	7	7	8	8	10	10	10	10	10
Shaft Diameter "D" Inches	Nominal	1/2	5/8	3/4	7/8	1	1 1/8	1 1/4	1 3/8	1 1/2	1 5/8	1 3/4	1 7/8	2	2 1/8	2 1/4	2 3/8	2 1/2	2 5/8
	Actual	.500 .498	.625 .623	.750 .748	.875 .873	1.000 .998	1.125 1.123	1.250 1.248	1.375 1.373	1.500 1.498	1.625 1.623	1.750 1.748	1.875 1.872	2.000 1.997	2.125 2.122	2.250 2.247	2.375 2.372	2.500 2.497	2.625 2.621
Keyway Width "W"		1/8	3/16	3/16	3/16	1/4	1/4	1/4	5/16	3/8	3/8	3/8	1/2	1/2	1/2	5/8	5/8	5/8	5/8
Keyway Flat Length "FL"		1.25	1.25	1.25	1.25	1.25	1.5	1.5	1.75	1.75	1.75	2	2	2	2.5	2.5	2.5	2.5	2.5

*These are the minimum shaft lengths that can be ordered when Joyce Model "S" sleeve- or "F" flange-type couplings are selected. See pages 188 and 189 for coupling information.

ACCESSORIES SHAFTING

To use this chart, follow these steps:

1. Find a "Shaft Torque" value in the far left column that is greater than, or equal to, your calculated torque value.
2. Move to the second column to find your "Nominal Shaft Diameter" (round up to arrive at an offered shaft size).
3. The third column shows the maximum allowable shaft span before supports (pillow blocks) are required.
4. Compare your actual shaft speed (RPM) with the maximum allowable speed (RPM) for the shaft you have chosen. If you are above the allowable shaft speed, then increase the shaft size until it falls into the allowable range.

Diameter Selection Chart			Maximum Allowable RPMs***										
Shaft Torque (Inch/Lbs.)	Nominal Shaft Diameter* (Inches)	Maximum** Distance Between Supports (Inches)	Shaft Lengths (Inches)										
			36	48	60	72	84	96	108	120	132	144	156
20	0.51	54.6	1802	1014	649	450	331	253	200	162	134	113	96
40	0.73	61.3	2143	1205	771	536	394	301	238	193	159	134	114
50	0.81	65.5	2372	1334	854	593	436	333	264	213	176	148	126
80	0.87	68.8	2548	1433	917	637	468	358	283	229	190	159	136
100	0.92	71.4	2695	1516	970	674	495	379	299	243	200	168	143
150	1.01	76.3	2982	1677	1074	746	548	419	331	268	222	186	159
200	1.09	80.1	3204	1802	1154	801	589	451	356	288	238	200	171
250	1.15	83.1	3388	1906	1220	847	622	476	376	305	252	212	180
300	1.21	85.7	3546	1995	1277	887	651	499	394	319	264	222	189
350	1.25	87.9	3686	2073	1327	921	677	518	410	332	274	230	196
400	1.30	89.9	3811	2144	1372	953	700	536	423	343	283	238	203
450	1.34	91.7	3925	2208	1413	981	721	552	436	353	292	245	209
500	1.37	93.3	4029	2266	1451	1007	740	567	448	363	300	252	215
600	1.44	96.2	4217	2372	1518	1054	775	593	469	380	314	264	225
700	1.49	98.7	4383	2465	1578	1096	805	616	487	394	326	274	233
800	1.54	100.9	4532	2549	1631	1133	832	637	504	408	337	283	241
900	1.59	102.9	4667	2625	1680	1167	857	656	519	420	347	292	249
1000	1.63	104.7	4792	2695	1725	1198	880	674	532	431	356	299	255
1250	1.72	108.7	5067	2250	1824	1267	931	712	563	456	377	317	270
1500	1.80	112.0	5303	2983	1909	1326	974	746	589	477	394	331	282
1750	1.92	114.9	5511	3100	1984	1378	1012	775	612	496	410	344	293
2000	1.94	117.5	5698	3205	2051	1425	1047	801	633	513	424	356	303
2250	2.00	119.8	5869	3301	2113	1467	1078	825	652	528	437	367	313
2500	2.05	122.0	6025	3389	2169	1506	1107	847	669	542	448	377	321
3000	2.15	125.7	6306	3547	2270	1577	1158	887	701	568	469	394	336
3250	2.19	127.4	6434	3619	2316	1608	1182	905	715	579	479	402	343
3500	2.23	129.0	6554	3687	2359	1639	1204	922	728	590	487	410	349
4000	2.31	131.9	6776	3812	2440	1694	1245	953	753	610	504	424	361
4500	2.38	134.5	6979	3926	2512	1745	1282	981	775	628	519	436	372
5000	2.44	136.9	7165	4030	2579	1791	1315	1008	796	645	533	448	382
6000	2.55	141.1	7499	4218	2700	1875	1377	1055	833	675	558	469	399
7000	2.65	144.8	7794	4384	2806	1949	1432	1096	866	701	580	487	415

Note: Shaded area exceeds maximum distance between supports. Pillow blocks are required.

*Shaft diameter is based on 0.08 degrees twist per foot of length.

**Maximum distance between supports is based on a maximum allowable deflection of 0.01 inches per foot of length.

***Maximum allowable RPMs is based on 80% of critical shaft speed.

Length Specifying Information

Joyce shafts can be ordered in 1/16 inch increments of length. When specifying shaft length, please refer to the table below to determine the decimal code for fractions of length.

Fraction	0	1/16	1/8	3/16	1/4	5/16	3/8	7/16	1/2	9/16	5/8	11/16	3/4	13/16	7/8	15/16
Decimal	.00	.06	.13	.19	.25	.31	.38	.44	.5	.56	.63	.69	.75	.81	.88	.94

Ordering Information

Example: A. For a 1/2" dia. x 33 3/8" long

Part Number = **S50-33.38**

B. For a 1 1/4" dia. x 110" long

Part Number = **S125-110.00**

C. For a 2 1/4" dia. x 58 7/16" long

Part Number = **S225-58.44**

CONTROLS MOTOR STARTERS

Joyce motor starters are the heart of a basic control system for a motorized jack, actuator, electric cylinder, or ComDRIVE® system. Motor starters include extend and retract push buttons for momentary operation; an illuminated power-on light lets operators easily determine if there is power to the system.

Other standard features:

- Limit switch terminals for two end-of-travel limits
- 1/3 - 15 HP motors standard
- 200, 230, 460, and 575 volts standard, three-phase power requirements
- NEMA 4 enclosure
- All three-phase motor starters include IEC motor overload protection

Ordering information:

Each model's part number begins with the prefix 07990377. To this prefix, add the appropriate suffix from the chart below. For example: 07990377-17 refers to a motor starter for a 1 1/2 horsepower, 200 volt motor.



Motor HP Starter Part Number Suffix				
Motor HP	Voltage			
	200	230	460	575
1/3	-1	-2	-3	-4
1/2	-5	-6	-7	-8
3/4	-9	-10	-11	-12
1	-13	-14	-15	-16
1 1/2	-17	-18	-19	-20
2	-21	-22	-23	-24
3	-25	-26	-27	-28
5	-29	-30	-31	-32
7 1/2	-33	-34	-35	-36
10	-37	-38	-39	-40
15	-41	-42	-43	-44

Standard Dimensions			
Amp Rating*	A	B	C
≤ 25 amp	12	12	6.64
> 25 amp	14	12	6.64

*Amp rating is dependant on HP and voltage.

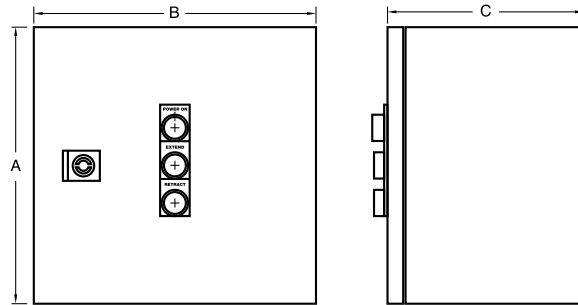

Many options are available including:

- NEMA 4X enclosure
- 50 Hz motors
- International voltages
- Single-phase motors
- Multiple starters in a single enclosure
- Starters for larger horsepower motors
- Explosion-proof enclosure
- Maintained contact control
- Stack lights
- Audible alarm

Note: Drawings are artist's conception — not for certification; dimensions are subject to change without notice.

CONTROLS VARIABLE SPEED POSITIONING SYSTEM

Joyce Variable Speed Positioning System (VSPS) is a programmable controller that increases the capability of motorized jacks by allowing the operator to easily program up to ten stopping positions.

It is housed in two NEMA 4 enclosures, one for the VFD the other for the PLC (as shown). The VSPS includes an HMI display that indicates the current position as well as the stopping location.

Other standard features:

- Limit switch terminals for two end-of-travel limits
- Speed control dial (real time)
- Emergency stop push button
- 1/3 – 3 HP motor control standard
- 200, 230, 460 and 575 volts standard, three-phase power requirements
- 3" HMI display
- Manual jog

Ordering information:

Each model's part number begins with the prefix 07990951. To this prefix add the appropriate suffix from the chart below. For example: 07990951-2 refers to a VSPS control for a 1/3 horsepower, 230 volt motor.

Motor HP Starter Part Number Suffix			
Motor HP	Voltage		
	200	230	460
1/3	-1	-2	-3
1/2	-5	-6	-7
3/4	-9	-10	-11
1	-13	-14	-15
1 1/2	-17	-18	-19
2	-21	-22	-23
3	-25	-26	-27

Standard Dimensions				
Item	Motor HP	A	B	C
PLC Box	1/3 - 3	12"	12"	6"
VFD Box	1/3 - 3	20"	20"	10"

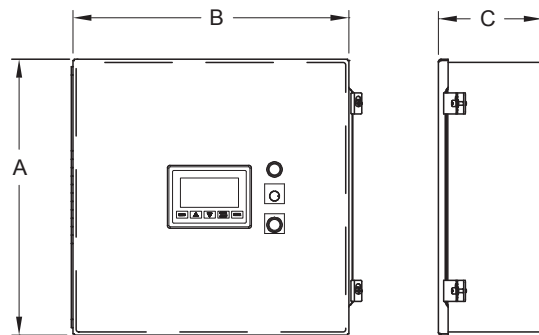

Many options are available including:

- NEMA 4X enclosure
- 50 Hz motors
- International voltages
- Single-phase motors
- 5 horsepower and larger
- Pendant controls
- Maintained contact control
- Stack lights
- Audible alarm

Note: Drawings are artist's conception — not for certification; dimensions are subject to change without notice.

CONTROLS LINEAR ACTUATORS

Joyce/Dayton offers a variety of control options for linear actuators and small horsepower systems. See the charts below for specific information describing various offerings.

Features Include:

- NEMA 12 CSA approved enclosure
- Rocker-type contact switch
- Momentary contact for extend/retract
- Terminal strip for motor and incoming power connections

Controls for Joyce 1500 pound linear actuators are shown below.

LA152 - 1500 Lb DC Actuator Controls					
Input - Output	Amp rating	Part Number	A	B	C
12 VDC - 12 VDC with wired relays	35 amp	07990812	6"	6"	4"

LA155 - 1500 Lb AC Actuator Controls					
Input - Output	Amp Rating	Part Number	A	B	C
120 VAC - 120 VAC with wired relays	15 amp	07990762-1	8"	8"	4"

General purpose actuator controls

12 VDC Controls					
Input - Output	Amp Rating	Part Number	A	B	C
12 VDC - 12 VDC	8.5 amp	07990938	8"	8"	4"
	25 amp	07990939			
	37 amp	07990940			

120 VAC to 12 VDC Controls					
Input - Output	Amp rating	Part Number	A	B	C
120 VAC - 12 VDC	8.5 amp	07990931	16 3/8"	10 3/4"	6"
	25 amp	07990932			
	37 amp	07990933			

120 VAC Controls					
Input - Output	Amp rating	Part Number	A	B	C
120 AC - 120 VAC	15 amp	07990964	6"	6"	4"



AC and DC Controls

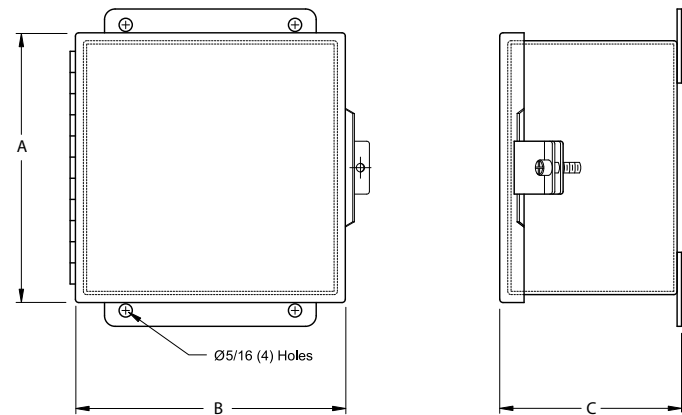

Note: All packaged controls include a terminal strip and are internally wired, ready for connection to the power source. All connections must be made according to the instructions accompanying each control package.

Note: Drawings are artist's conception — not for certification; dimensions are subject to change without notice.

COMMON SYSTEM ARRANGEMENTS

Joyce jacks, miter gear boxes, couplings and motorized ComDRIVES® can be used in a number of system arrangements. Several are shown here.

Because jacks selected for systems have uniform lifting speeds and are fully synchronized, unevenly distributed loads can be raised, lowered, and positioned in unison. Jacks of differing capacities may be used in the same system as long as driven shafts turns per 1" of travel are the same.

Arrows indicate the rotational direction to raise the load.

Wormgear I System Features ComDRIVE®

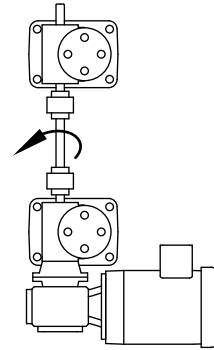

Wormgear U System

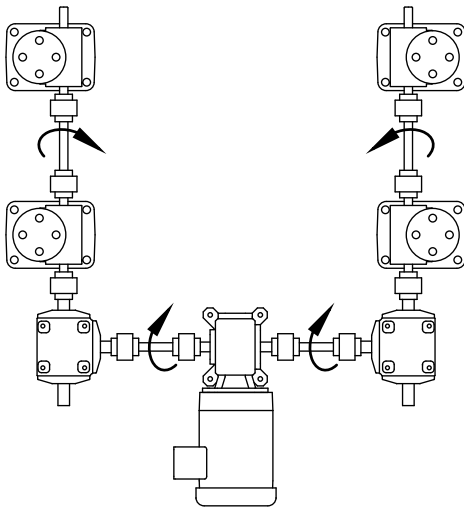

Wormgear T System

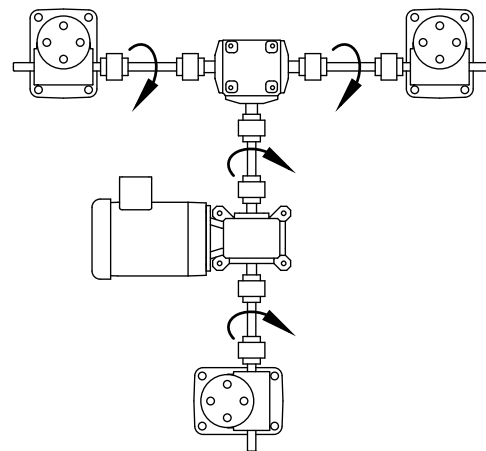

Wormgear H System

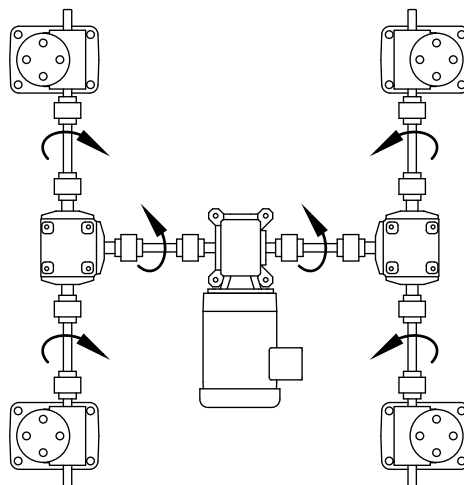

Bevel Gear U System

