

## Angle Valve

electromagnetically actuated with automatic voltage  
adaptation 90 ... 264 V

AVC 016 MA/X

AVC 025 MA/X

AVC 040 MA/X

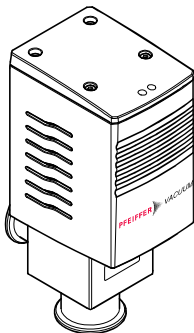

Operating Instructions  
Incl. Manufacturer's Declaration

## Product Identification

In all communications with PfeifferVacuum, please specify the information given on the product nameplate. For convenient reference copy that information into the space provided below.

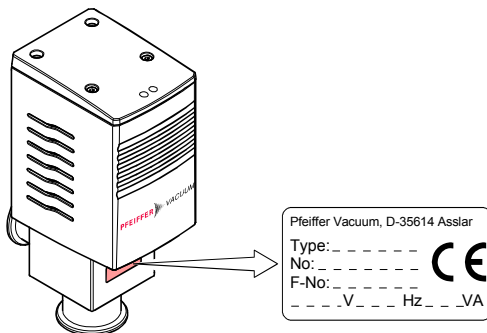

## Validity

This document applies to products with the following part numbers:

PF A34 506	(DN 16 ISO-KF, aluminum housing)
PF A34 536	(DN 16 ISO-KF, stainless steel housing)
PF A44 506	(DN 25 ISO-KF, aluminum housing)
PF A44 536	(DN 25 ISO-KF, stainless steel housing)
PF A54 506	(DN 40 ISO-KF, aluminum housing)
PF A54 536	(DN 40 ISO-KF, stainless steel housing)

The part number (No) can be taken from the product nameplate. If not indicated otherwise in the legends, the illustrations in this document correspond to the valve with the vacuum connection DN 40 ISO-KF. They apply to valves with other vacuum connections by analogy.

We reserve the right to make technical changes without prior notice.

All dimensions in mm.

## Intended Use

The electromagnetically actuated bellows sealed angle valves are used as shut-off or venting devices in vacuum applications.

## Functional Principle

The angle valves are opened electromagnetically and closed by means of a prestressed pressure spring. They close, or remain closed, on power loss.

## Scope of Delivery

- 1× valve
- 1× connector, 3 poles
- 1× connector, 4 poles
- 1× Operating Instructions
- 1× Betriebsanleitung

## Contents

Product Identification	2
Validity	2
Intended Use	3
Functional Principle	3
Scope of Delivery	3

<b>1</b>	<b>Description</b>	<b>5</b>
1.1	Operating modes	5
1.2	Indication of Positions and Faults	6
1.3	Position Indicator (in REMOTE mode only)	7
<b>2</b>	<b>Safety</b>	<b>8</b>
2.1	Symbols Used	8
2.2	Personnel Qualifications	8
2.3	General Safety Instructions	9
2.4	Liability and Warranty	9
<b>3</b>	<b>Technical Data</b>	<b>10</b>
<b>4</b>	<b>Installation</b>	<b>13</b>
4.1	Vacuum Connection	13
4.2	Power Connection	15
<b>5</b>	<b>Operation</b>	<b>23</b>
<b>6</b>	<b>Deinstallation</b>	<b>24</b>
6.1	Power Connection	24
6.2	Vacuum Connection	27
<b>7</b>	<b>Maintenance / Repair</b>	<b>29</b>
7.1	Replacing/Cleaning the O-rings and Bellows	30
7.2	Replacing the Electronics and the Stroke Solenoid	34
<b>8</b>	<b>Spare Parts</b>	<b>39</b>
<b>9</b>	<b>Returning the Product</b>	<b>41</b>
<b>10</b>	<b>Disposal</b>	<b>42</b>
	<b>Declaration of Contamination</b>	<b>43</b>
	<b>Manufacturer's Declaration</b>	<b>44</b>

For cross-references within this document, the symbol (→  XY) is used.

# 1 Description

## 1.1 Operating modes

The angle valve has two operating modes:

- REMOTE mode  
Drive via control voltage 15 ... 30 VDC.
- LOCAL mode  
Drive via supply voltage 90 ... 264 VAC.

The operating mode is selected by setting a switch (→  17).

### REMOTE mode

In the REMOTE mode, the supply voltage of 90 ... 264 VAC is constantly fed. The angle valve is opened and closed via the control contact (0 VDC).

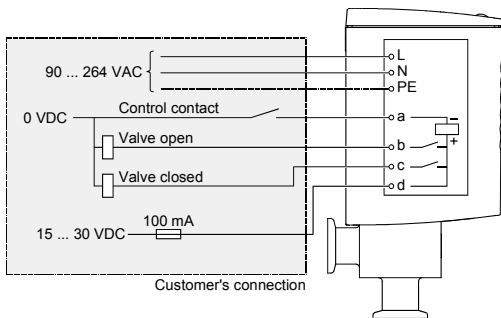

## LOCAL mode

The angle valve is opened and closed directly via the supply voltage.

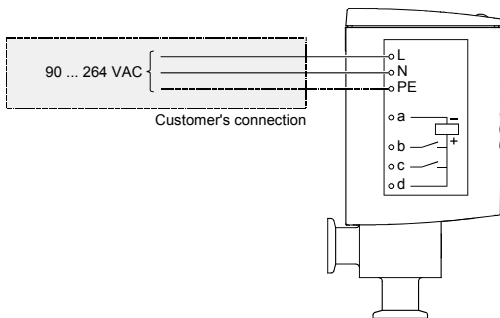

## 1.2 Indication of Positions and Faults

- Green LED lit = valve open
- Red LED lit = valve closed
- Red LED flashing = fault

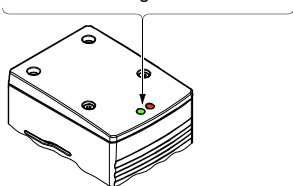

### 1.3 Position Indicator (in REMOTE mode only)

The integrated position indicator allows for polling the valve positions. In the event of a fault, the signal "valve closed" is constantly fed.

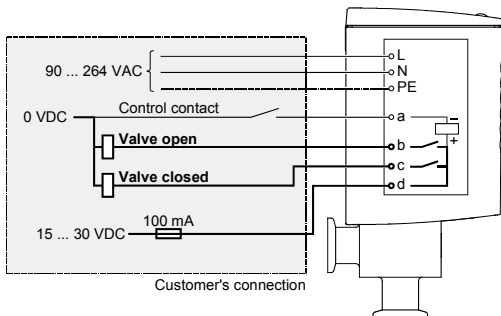

## 2 Safety

### 2.1 Symbols Used



**DANGER**

Information on preventing any kind of physical injury.



**WARNING**

Information on preventing extensive equipment and environmental damage.



**Caution**

Information on correct handling or use. Disregard can lead to malfunctions or minor equipment damage.



Notice

### 2.2 Personnel Qualifications



**Skilled personnel**

All work described in this document may only be carried out by persons who have suitable technical training and the necessary experience or who have been instructed by the end-user of the product.



## 2.3 General Safety Instructions

- Adhere to the applicable regulations and take the necessary precautions for the process media used.  
Consider possible reactions with the product materials (→  11).
- Adhere to the applicable regulations and take the necessary precautions for all work you are going to do and consider the safety instructions in this document.
- Before beginning to work, find out whether any vacuum components are contaminated. Adhere to the relevant regulations and take the necessary precautions when handling contaminated parts.

Communicate the safety instructions to all other users.

## 2.4 Liability and Warranty

Pfeiffer Vacuum assumes no liability and the warranty becomes null and void if the end-user or third parties

- disregard the information in this document
- use the product in a non-conforming manner
- make any kind of interventions (modifications, alterations etc.) on the product
- use the product with accessories not listed in the product documentation.

The end-user assumes the responsibility in conjunction with the process media used.

### 3 Technical Data

Vacuum connection	DN 16 ISO-KF	DN 25 ISO-KF	DN 40 ISO-KF
Actuation	opening: electromagnetically closing: by pressure spring		
Supply voltage <sup>1)</sup>	90 ... 264 VAC		
Frequency	47 ... 63 Hz		
Power consumption	400 W (max. upon switching on)		
Pickup-/Holding power	405 / 8.1 W	416 / 8.3 W	367 / 7.5 W
Control voltage	15 ... 30 VDC		
Power consumption	1.5 ... 5 mA		
Position indicator			
Switching voltage <sup>2)</sup>	15 ... 30 VDC		
Switching current <sup>3)</sup>	100 mA		
Cable diameter			
Feeder line	5 ... 7 mm		
Control cable	5 ... 7 mm		
Mounting orientation <sup>4)</sup>	any		
Flow direction	any		
Cycle life <sup>5)</sup>	2 million		
Switching frequency			
at 40 °C <sup>6)</sup>	30 / min		
at 50 °C <sup>6)</sup>	20 / min		

<sup>1)</sup> The feeder line must be fuse-protected with  $\leq 16$  A

<sup>2)</sup> Corresponds to the control voltage

<sup>3)</sup> Must be protected with a quick-acting 100 mA fuse provided by the end-user

<sup>4)</sup> Recommended mounting orientation: valve seat toward vacuum chamber.

<sup>5)</sup> Cycles without expendable parts (seals) and under clean operating conditions

<sup>6)</sup> Ambient temperature

Vacuum connection	DN 16 ISO-KF	DN 25 ISO-KF	DN 40 ISO-KF
Opening time	100 ms	120 ms	230 ms
Closing time	220 ms	220 ms	650 ms
Dead time <sup>7)</sup>	40 ms	140 ms	450 ms
Tightness	1×10 <sup>-9</sup> mbar l/s		
Pressure max.	3 bar (absolute)		
Operating pressure min.	1×10 <sup>-8</sup> mbar		
Operating pressure max.	1.3 bar	1.3 bar	1 bar
Pressure difference $\Delta p$ in closing direction	1.3 bar	1.3 bar	1.3 bar
in opening direction	1.3 bar	1.3 bar	1 bar
Opens to a pressure difference $\Delta p$	1.3 bar		
Conductance <sup>8)</sup>	4 l/s	13 l/s	35 l/s
Ambient temperature	0 ... 50 °C		
Degree of protection	IP 54		
Materials			
Housing			
Aluminum	EN-AW 6060		
Stainless steel	1.4301		
Inside section	stainless steel		
Seals	FPM		
Shell	ABS, Lexan		
Weight			
Aluminum	1.1 kg	1.9 kg	4.3 kg
Stainless steel	1.2 kg	2.0 kg	4.4 kg

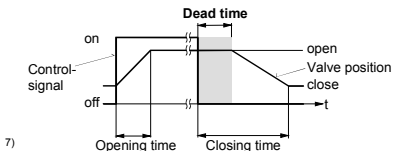





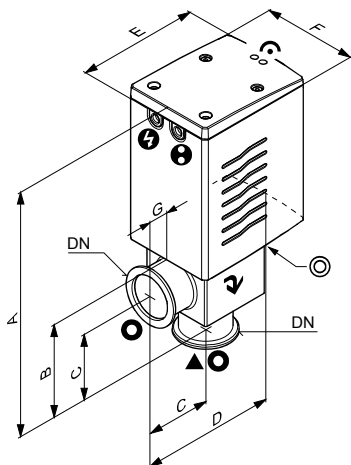

7)

8) For air with molecular flow

Dimensions [mm]





-  Visual position indicator
-  Leak detection opening
-  Electrical connection
-  Position indicator connection
-  Flow direction
-  Valve seat site
-  Protective lid

Aluminum-housing	DN	A	B	C	D	E	F	G
	DN 16 ISO-KF	170.9	51.4	40	96	86	59	10
	DN 25 ISO-KF	193	64.9	50	112.7	97.3	70	15.4
	DN 40 ISO-KF	246	92.9	65	139	119.5	90	19.5
Stainless steel-housing	DN	A	B	C	D	E	F	G
	DN 16 ISO-KF	172.9	53.4	40	96	86	59	10
	DN 25 ISO-KF	196.4	68.3	50	112.7	97.3	70	15.4
	DN 40 ISO-KF	249	95.9	65	139	119.5	90	19.5

## 4 Installation

### 4.1 Vacuum Connection

 **DANGER**



**DANGER:** overpressure in the vacuum system >1 bar

Injury caused by released parts and harm caused by escaping process gases can result if clamps are opened while the vacuum system is pressurized.

Do not open any clamps while the vacuum system is pressurized. Use the type clamps which are suited to overpressure.

 **Caution**



**Caution:** vacuum component

Dirt and damages impair the function of the vacuum component.

When handling vacuum components, take appropriate measures to ensure cleanliness and prevent damages.

 **Caution**



**Caution:** dirt sensitive area

Touching the product or parts thereof with bare hands increases the desorption rate.



Always wear clean, lint-free gloves and use clean tools when working in this area.

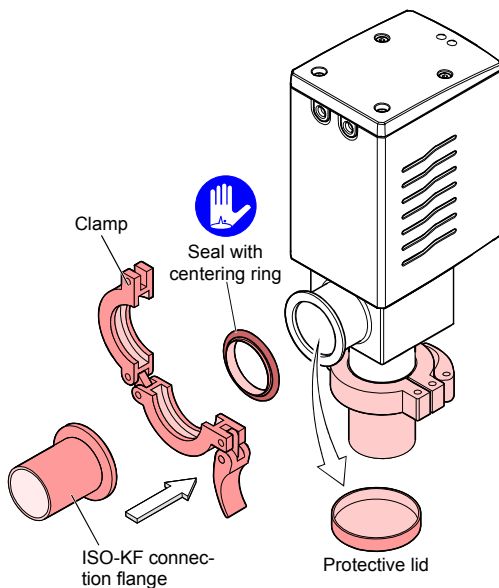

Remove the protective lids and connect the product to the vacuum system.





Keep the protective lids.

## 4.2 Power Connection

	 <b>DANGER</b>
	<p><b>DANGER: mains voltage</b></p> <p>Products that are not professionally connected to ground can be hazardous in the event of a malfunction.</p> <p>Connect the product according to the local regulations and ground it correctly.</p>

	 <b>Caution</b>
	<p><b>Caution: electrostatic fields</b></p> <p>If the valve is installed in the vicinity of switched or electronically controlled heavy electric loads, such as furnaces, heaters, motors or RF generators, disturbances may occur.</p> <p>Install a mains filter in the supply line of the valve.</p>

	 <b>Caution</b>
	<p><b>Caution: high voltage tests</b></p> <p>The valve is factory tested according to the EN 60 204 standard. Additional high voltage tests may destroy the valve.</p> <p>Do not carry out any further high voltage tests.</p>

- 1 Unscrew the hexagon socket head screws and remove the cover.

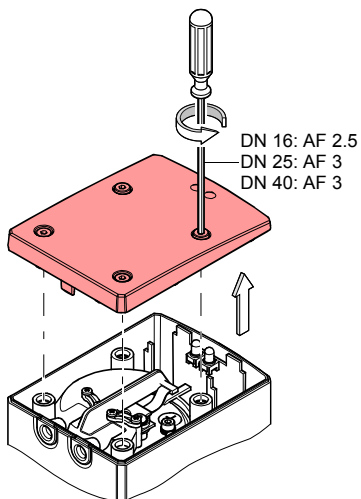



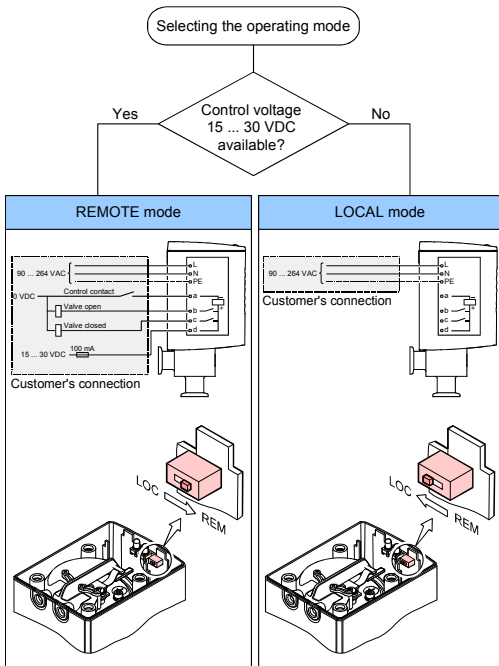

- 2** The operating mode must be selected before the electrical connection is established. If a 15 ... 30 VDC control voltage is available, choose REMOTE.



- 3** Prepare the connector for the feeder line, mount the cable tie ...

**DANGER**



**DANGER: moving parts**  
When the product is connected to the supply media, parts can start moving. Moving parts can catch parts of the body and cause injuries.

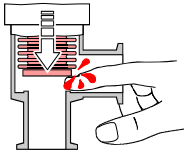

The connection to the power supply may only be established if

- the power supply is de-energized
- the product is installed in a vacuum system or
- the moving parts are protected to avoid accidental contact.

-  The cable must meet the following specifications:
- flexible
  - conductor cross-section  $\leq 1 \text{ mm}^2$
  - appropriate for 230 V basic insulation
  - 3 poles protective conductor (P+N+PE)
  - 5 ... 7 mm diameter  
(for the cable feedthroughs to meet the IP 54 specifications)

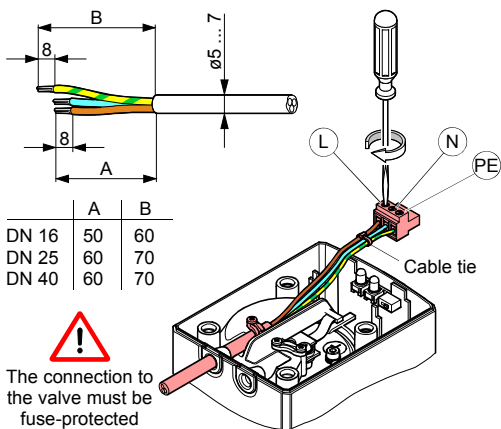

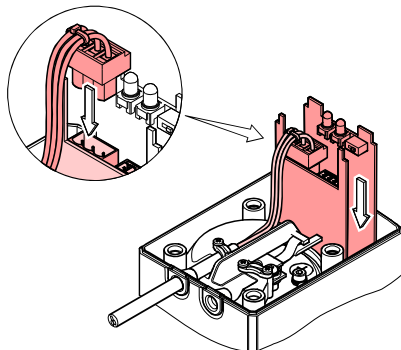

  
 The connection to the valve must be fuse-protected with  $\leq 16$  A.

... and plug in the connector.



- 4 Prepare the connector for the control cable (for REMOTE mode only), mount the cable tie ...

**DANGER**



**DANGER: moving parts**  
When the product is connected to the supply media, parts can start moving. Moving parts can catch parts of the body and cause injuries.

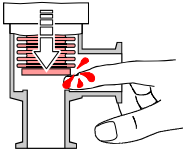

The connection to the control cable may only be established if

- the power supply/ control cable is de-energized
- the product is installed in a vacuum system or
- the moving parts are protected to avoid accidental contact.



The cable must meet the following specifications:

- flexible
- conductor cross-section  $<0.75 \text{ mm}^2$
- appropriate for 230 V basic insulation
- 4 poles protective conductor
- 5 ... 7 mm diameter  
(for the cable feedthroughs to meet the IP 54 specifications)

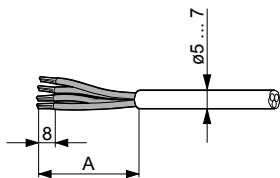

	A
DN 16	50
DN 25	60
DN 40	60

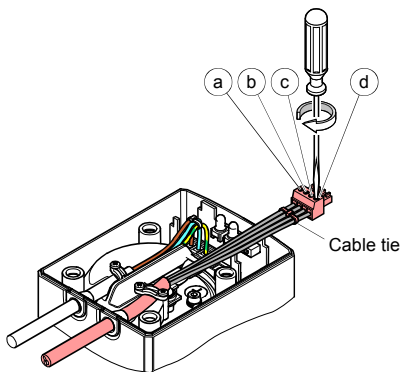
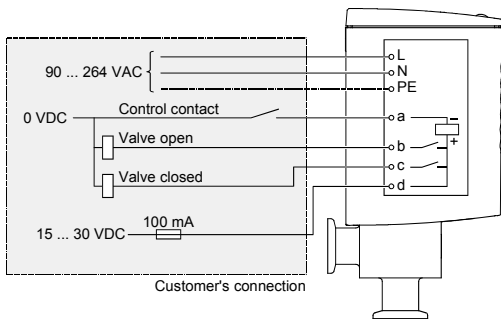

... and plug in the connector.

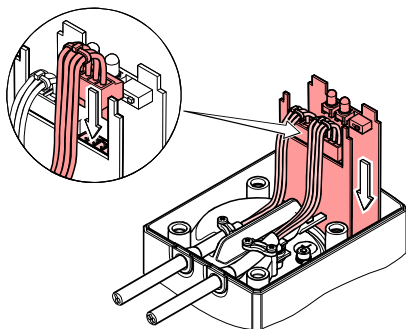



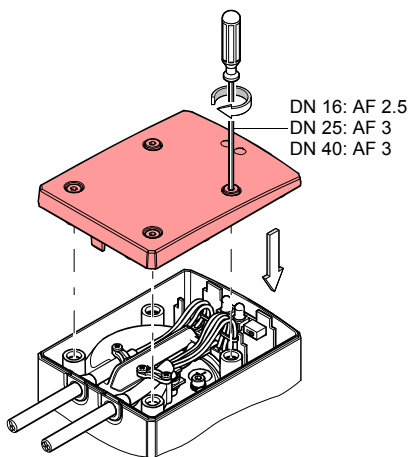





**5** Mount the cover.



## 5 Operation

The product is ready for operation as soon as it has been installed.

### Indication of positions and faults

	REMOTE mode	LOCAL mode
Valve closed	 red LED lit	 both LEDs dark
Valve opening	 both LEDs dark	 red LED lights up briefly
Valve open	 green LED lit	 green LED lit
Fault	 red LED flashing	 red LED flashing

### Signaling behavior

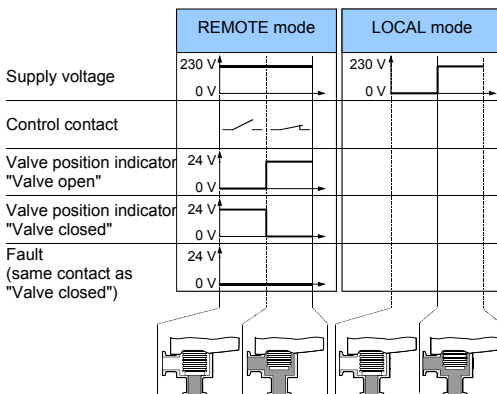



## 6 Deinstallation

### Precondition

- Vacuum system vented.

### 6.1 Power Connection

**DANGER**



**DANGER: moving parts**

When the product is disconnected from the supply media, parts can start moving. Moving parts can catch parts of the body and cause injuries.

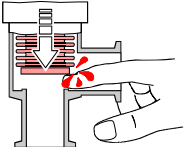

The product may only be disconnected from the power supply if

- the product is installed in a vacuum system or
- the moving parts are protected to avoid accidental contact.



 **DANGER**

**DANGER:** mains voltage  
Touching live parts is hazardous.

Switch all mains and control voltage sources off and secure them against inadvertent power-on before performing any electrical work on the product.

- 1** Remove the cover (→  16).
- 2** Disconnect the feeder line.

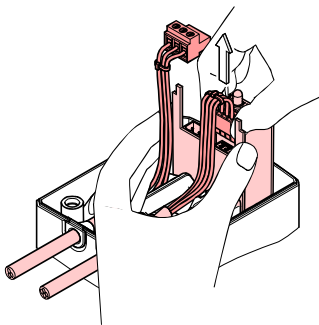



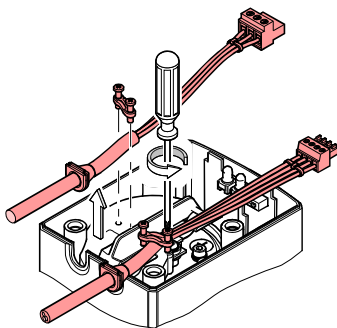

- 3** Deinstall the strain relief.





- 4** Mount the cover (→ 22).

## 6.2 Vacuum Connection

	 <b>DANGER</b>
	<p><b>DANGER: contaminated parts</b> Contaminated parts can be detrimental to health and environment. Before beginning to work, find out whether any parts are contaminated. Adhere to the relevant regulations and take the necessary precautions when handling contaminated parts.</p>

	 <b>Caution</b>
	<p><b>Caution: vacuum component</b> Dirt and damages impair the function of the vacuum component. When handling vacuum components, take appropriate measures to ensure cleanliness and prevent damages.</p>

	 <b>Caution</b>
	<p><b>Caution: dirt sensitive area</b> Touching the product or parts thereof with bare hands increases the desorption rate. Always wear clean, lint-free gloves and use clean tools when working in this area.</p>

Remove the valve from the vacuum system and install the protective lids.

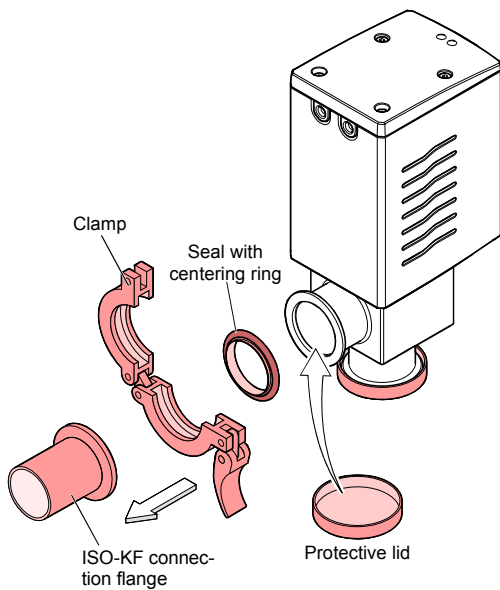

## 7 Maintenance / Repair

 **DANGER**

**DANGER:** contaminated parts  
Contaminated parts can be detrimental to health and environment.

Before beginning to work, find out whether any parts are contaminated. Adhere to the relevant regulations and take the necessary precautions when handling contaminated parts.

 **Caution**

**Caution:** vacuum component  
Dirt and damages impair the function of the vacuum component.

When handling vacuum components, take appropriate measures to ensure cleanliness and prevent damages.

 **Caution**

**Caution:** dirt sensitive area  
Touching the product or parts thereof with bare hands increases the desorption rate.

Always wear clean, lint-free gloves and use clean tools when working in this area.

## 7.1 Replacing/Cleaning the O-rings and Bellows

### Precondition

- The valve has been deinstalled (Deinstallation →  24)

- 1 Remove the cap screws and the cover.

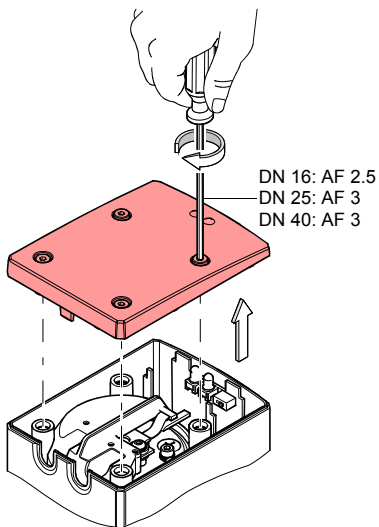

- 2** Remove the cap screws and the actuator from the housing.



The actuator can be rotated by 90°.



When reinstalling the actuator tighten the cap screws evenly and crosswise.

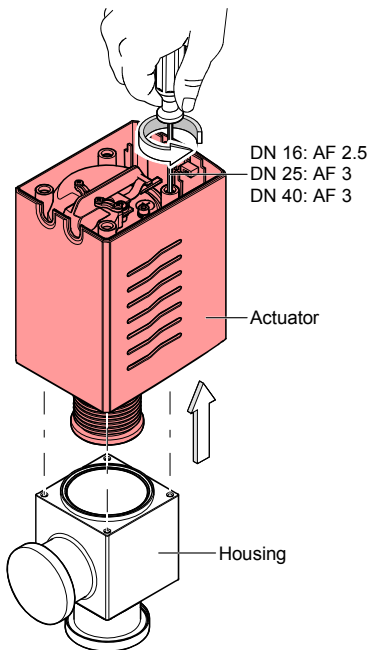

- 3** Unscrew the bellows (Spare Parts →  39).

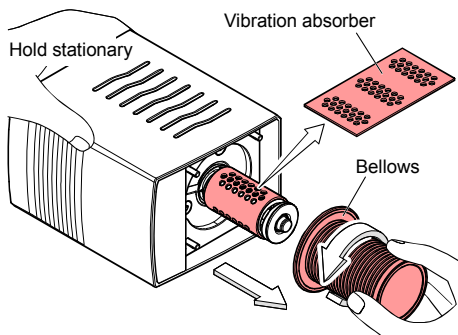

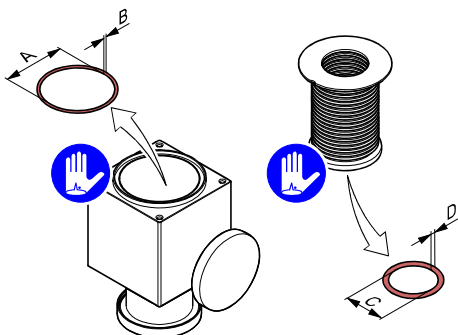

- 4** Remove the seals (Spare Parts →  39).



O-Ring, FPM	$\varnothing A \times B$	$\varnothing C \times D$
DN 16 ISO-KF	$\varnothing 28.3 \times 1.78$	$\varnothing 17.04 \times 3.53$
DN 25 ISO-KF	$\varnothing 37.82 \times 1.78$	$\varnothing 24.99 \times 3.53$
DN 40 ISO-KF	$\varnothing 56.87 \times 1.78$	$\varnothing 40.87 \times 3.53$



- 5 Remove the protective lids and clean the parts.

	 <b>DANGER</b>
	<p><b>DANGER: cleaning agents</b></p> <p>Cleaning agents can be detrimental to health and environment.</p> <p>Adhere to the relevant regulations and take the necessary precautions when handling and disposing of cleaning agents. Consider possible reactions with the product materials (→  11).</p>

#### Procedure

- Carefully clean the parts with a grease solving, non-scouring cleaner.
- After cleaning the parts should preferably be rinsed with alcohol and subsequently heated to  $\approx 50^{\circ}\text{C}$  in an oven or with an industrial blower.
- Carefully clean the sealing surfaces with a lint-free cloth soaked with alcohol. Allow them to dry.
- 

- 6 Proceed in reverse order to reassemble the product.





Be careful to insert the O-rings level into the grooves without twisting them.

After reassembly, a few switching cycles should be performed in order for the O-rings to perfectly adapt to the sealing surfaces. Take the necessary precautions for this procedure.

## 7.2 Replacing the Electronics and the Stroke Solenoid

### Preconditions

- Valve deinstalled (→  24)
- Actuator removed from the housing (→  30, ❶ und ❷)

- ❶ Remove the ground conductor and the position indicator.

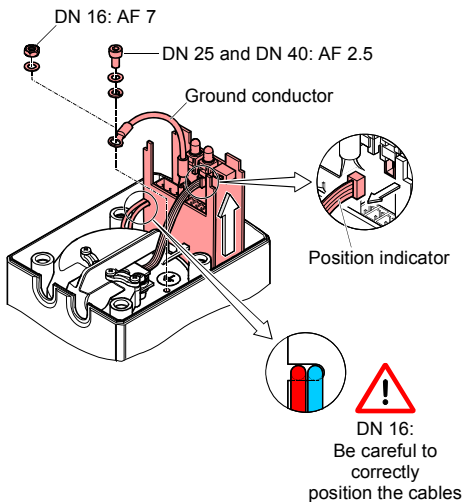

- 2** Remove the ground conductor, unsolder the red and the blue wire of the electronics (Spare Parts → 39).

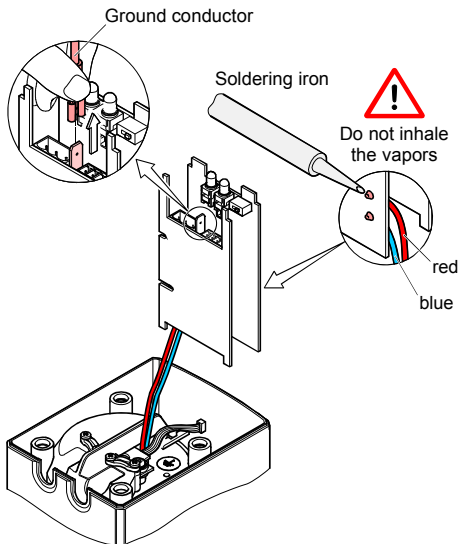

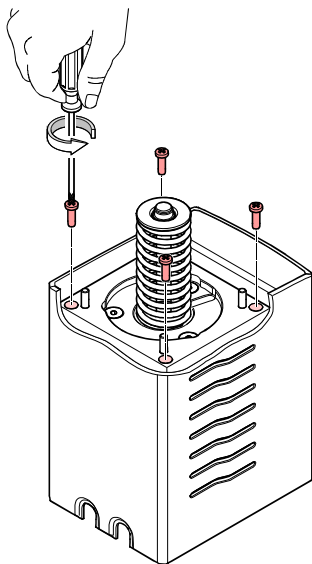
**3** Unscrew the screws ...

... and remove the stroke solenoid (Spare Parts →  39).

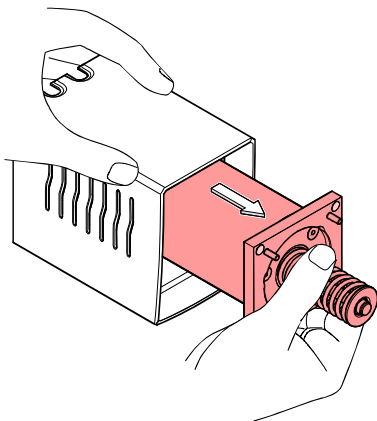

Mount the stroke solenoid in this position

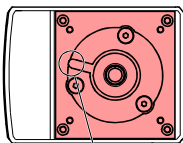

Leak detection opening

- 4** Remove the position indicator.

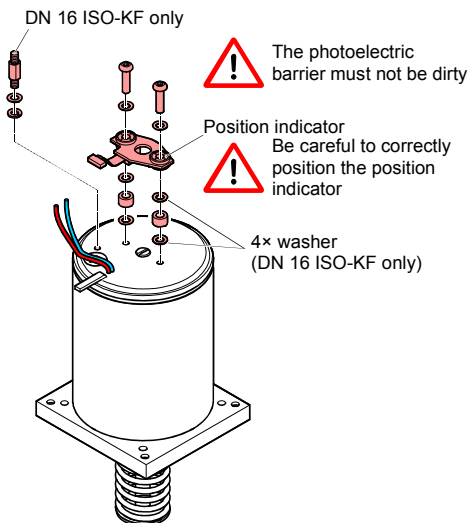

- 5** Proceed in reverse order to reassemble the electronics and the stroke solenoid.

## 8 Spare Parts

### Seal kit



	Ordering number
DN 16 ISO-KF, comprising 1 O-ring, $\varnothing 17.04 \times 3.53$ 1 O-ring, $\varnothing 28.3 \times 1.78$	PT 130 300-T
DN 25 ISO-KF, comprising 1 O-ring, $\varnothing 24.99 \times 3.53$ 1 O-ring, $\varnothing 37.82 \times 1.78$	PT 130 301-T
DN 40 ISO-KF, comprising 1 O-ring, $\varnothing 40.87 \times 3.53$ 1 O-ring, $\varnothing 56.87 \times 1.78$	PT 130 302-T

### Bellows cpl.

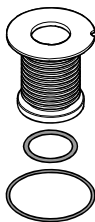

	Ordering number
DN 16 ISO-KF, comprising 1 bellows 1 O-ring, $\varnothing 17.04 \times 3.53$ 1 O-ring, $\varnothing 28.3 \times 1.78$	PT 130 303-T
DN 25 ISO-KF, comprising 1 bellows 1 O-ring, $\varnothing 24.99 \times 3.53$ 1 O-ring, $\varnothing 37.82 \times 1.78$	PT 130 304-T
DN 40 ISO-KF, comprising 1 bellows 1 O-ring, $\varnothing 40.87 \times 3.53$ 1 O-ring, $\varnothing 56.87 \times 1.78$	PT 130 305-T

### Electronics cpl.

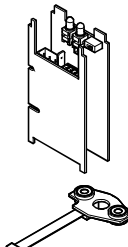
		Ordering number
	Comprising	PT 130 311-T
	1 electronics 1 position indicator	

### Stroke solenoid cpl.

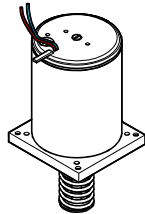
		Ordering number
	DN 16 ISO-KF 1 stroke solenoid with compression spring	PT 130 312-T
	DN 25 ISO-KF 1 stroke solenoid with compression spring	PT 130 313-T
	DN 40 ISO-KF 1 stroke solenoid with compression spring	PT 130 314-T



## 9 Returning the Product



### WARNING



WARNING: forwarding contaminated products  
Contaminated products (e.g. radioactive, toxic, caustic or microbiological hazard) can be detrimental to health and environment.

Products returned to Pfeiffer Vacuum should preferably be free of harmful substances. Adhere to the forwarding regulations of all involved countries and forwarding companies and enclose a duly completed declaration of contamination.

Products that are not clearly declared as "free of harmful substances" are decontaminated at the expense of the customer. Products not accompanied by a duly completed declaration of contamination are returned to the sender at his own expense.

## 10 Disposal



### DANGER



**DANGER:** contaminated parts

Contaminated parts can be detrimental to health and environment.

Before beginning to work, find out whether any parts are contaminated. Adhere to the relevant regulations and take the necessary precautions when handling contaminated parts.



### WARNING



**WARNING:** substances detrimental to the environment

Products or parts thereof (mechanical and electric components, operating fluids etc.) can be detrimental to the environment.

Dispose of such substances in accordance with the relevant local regulations.

### Separating the components

After disassembling the product, separate its components according to the following criteria:

- Contaminated components  
Contaminated components (radioactive, toxic, caustic or biological hazard etc.) must be decontaminated in accordance with the relevant national regulations, separated according to their materials, and disposed of.
- Other components  
Such components must be separated according to their materials and recycled.

# Declaration of Contamination

The service, repair, and/or disposal of vacuum equipment and components will only be carried out if a correctly completed declaration has been submitted. Non-completion will result in delay.

This declaration may only be completed (in block letters) and signed by authorized and qualified staff.

**1 Description of product**

Type \_\_\_\_\_  
 Part number \_\_\_\_\_  
 Serial number \_\_\_\_\_

**2 Reason for return**

\_\_\_\_\_

**3 Operating fluid(s) used (Must be drained before shipping.)**

\_\_\_\_\_

**4 Used in copper process**

no  yes  Seal product in plastic bag and mark it with a corresponding label.

**5 Process related contamination of product:**

toxic	no <input type="checkbox"/> 1)	yes <input type="checkbox"/>
caustic	no <input type="checkbox"/> 1)	yes <input type="checkbox"/>
biological hazard	no <input type="checkbox"/>	yes <input type="checkbox"/> 2)
explosive	no <input type="checkbox"/>	yes <input type="checkbox"/> 2)
radioactive	no <input type="checkbox"/>	yes <input type="checkbox"/> 2)
other harmful substances	no <input type="checkbox"/> 1)	yes <input type="checkbox"/>



1) or not containing any amount of hazardous residues that exceed the permissible exposure limits

2) Products thus contaminated will not be accepted without written evidence of decontamination.

The product is free of any substances which are damaging to health. yes

**6 Harmful substances, gases and/or by-products**

Please list all substances, gases, and by-products which the product may have come into contact with:

Trade/product name	Chemical name (or symbol)	Precautions associated with substance	Action if human contact

**7 Legally binding declaration:**

We hereby declare that the information on this form is complete and accurate and that we will assume any further costs that may arise. The contaminated product will be dispatched in accordance with the applicable regulations.

Organization/company \_\_\_\_\_

Address \_\_\_\_\_ Post code, place \_\_\_\_\_

Phone \_\_\_\_\_ Fax \_\_\_\_\_

Email \_\_\_\_\_

Name \_\_\_\_\_

Date and legally binding signature \_\_\_\_\_ Company stamp \_\_\_\_\_

This form can be downloaded from our website.

Copies:  
 Original for addressee - 1 copy for accompanying documents - 1 copy for file of sender

## Manufacturer's Declaration

as defined by the Directive relating to machinery 98/37/EC, Appendix IIB.



We, Pfeiffer Vacuum, hereby declare that putting the incomplete equipment mentioned below into operation is not permitted until evidence is given that the system into which that incomplete equipment shall be installed is in conformity with the provisions of the EC Directive relating to machinery.

We also declare that the equipment mentioned below complies with the provisions of the Directive relating to electrical equipment designed for use within certain voltage limits 2006/95/EC and the Directive relating to electromagnetic compatibility 2004/104/EC.

### Products

## Angle Valve

electromagnetically actuated with automatic voltage adaptation 90 ... 264 V

### Part numbers

PF A34 506	PF A44 506	PF A54 506
PF A34 536	PF A44 536	PF A54 536

### Standards

Harmonized and international/national standards and specifications:

- EN ISO 12100-1/-2 (Safety of machinery)
- EN 294 (Safety distances to prevent danger zones being reached by the upper limits)
- EN 349 (Minimum gaps to avoid crushing of parts of the human body)

- EN 61000-3-2 (EMC: Limits for harmonic current emissions)
- EN 61000-6-2 (EMC: generic immunity standard)
- EN 61000-6-3 (EMC: generic emission standard)
- EN 61010-1 (Safety requirements for electrical equipment for measurement, control and laboratory use)

## Signatures

Pfeiffer Vacuum GmbH, Asslar

20 July 2007



Manfred Bender  
Managing director

20 July 2007



Dr. Matthias Wiemer  
Managing director

## Notes

## Notes

**PFEIFFER**  **VACUUM**

*Berliner Strasse 43*

*D-35614 Asslar*

*Deutschland*

*Tel +49 (0) 6441 802-0*

*Fax +49 (0) 6441 802-202*

*info@pfeiffer-vacuum.de*

*Original: German BP 5272 BD / A (2008-01)*



bp5272ber a

*www.pfeiffer-vacuum.net*