

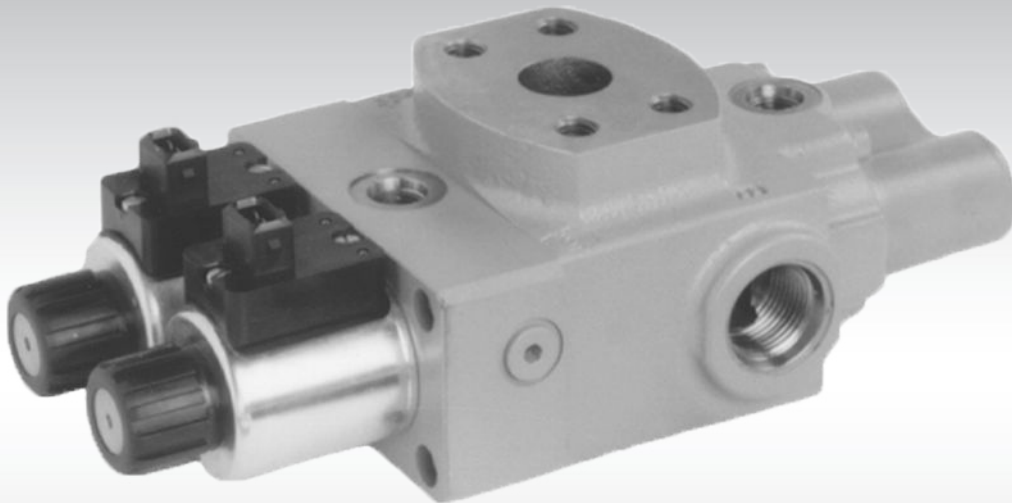

Technical Information

Series ASC

# Anti Spin Control Valve



**Revision history***Table of revisions*

<b>Date</b>	<b>Changed</b>	<b>Rev</b>
March 2014	Converted to Danfoss layout - DITA CMS	BA
July 2002	First edition	AA

**Contents**
**Overview**

Description.....	4
Features.....	4
Further System Components.....	4

**Sectional view**
**Circuit diagram**
**System schematic diagram**
**Technical specifications**

General specifications.....	8
Technical data.....	8
Fluid specifications.....	9

**General Technical Specifications**

Pressure Limits.....	10
Hydraulic Fluids.....	10
Temperature and Viscosity.....	10
Fluid and Filtration.....	11
Independent Braking System.....	12
Reservoir.....	12

**Functional Description**

General Description.....	13
ASC-Valve function.....	13

**Application Considerations**
**Availability**

Available Options.....	16
------------------------	----

**Technical data**

Pressure drop.....	17
Remaining flow at maximum closed position.....	17
Spool stroke versus current.....	18

**Outline Dimensions**

## Overview

## Description

The Danfoss Anti Spin Control valve (ASC-valve) is used e.g. in a propel drive line. The flow provided by a pump is split equally and ported to two propel motors, ensuring, both run at the same speed under all load, pressure, flow, and vehicle steering conditions. This prevents wheel slip and provides optimum vehicle traction. The ASC-valve concept allows therefore a wide variety of applications whenever equal flow share is demanded.

The ASC-valve in conjunction with a SUSMIC S1X microprocessor as well as steering and speed sensors combines the capabilities of modern digital electronics with the worldwide proven Danfoss hydrostatic components, to enhance the machine performance and operation.

The microprocessor-based SUSMIC S1X provides software flexibility and is designed for the future. With easy-to change parameters (in software) it is possible to make an individual setup for different machine types.

## Features

- Rugged design for mobile applications.
- Two “remaining flow” options available.
- Supply voltage 12 V<sub>DC</sub> or 24 V<sub>DC</sub>.
- Easy to service.
- Flexibility: 2 - 4 motors.
- Active while steering.
- Software optimization/adaption without hardware (orifice) changes.
- Individual setup per software:
  - Selection of different steering modes
  - Vehicle geometry
  - Track width
  - Wheel base
  - Wheel diameter
  - etc.

## Further System Components

- S1X-16 G2 AMP K196 S1X Electronic w/o CAN
- S1X-26 G2 AMP K196C S1X Electronic w CAN

**Technical Information    Series ASC Anti Spin Control Valve**

**Sectional view**

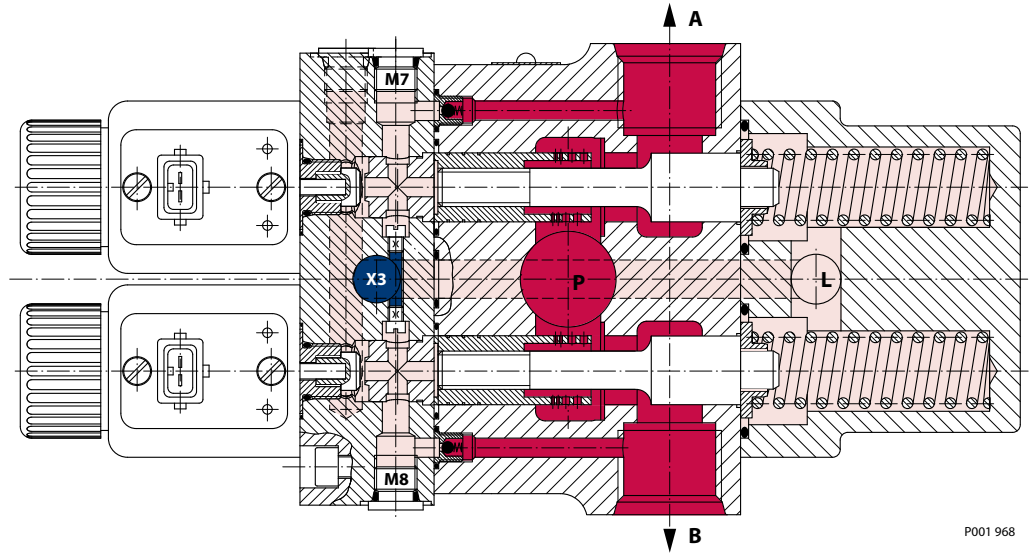

Circuit diagram

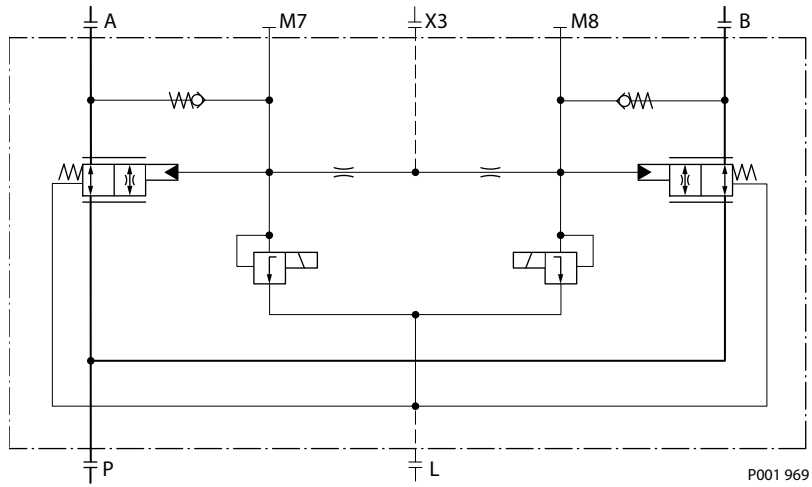

**System schematic diagram**

*Circuit Diagram – ASC-valve and System Components*

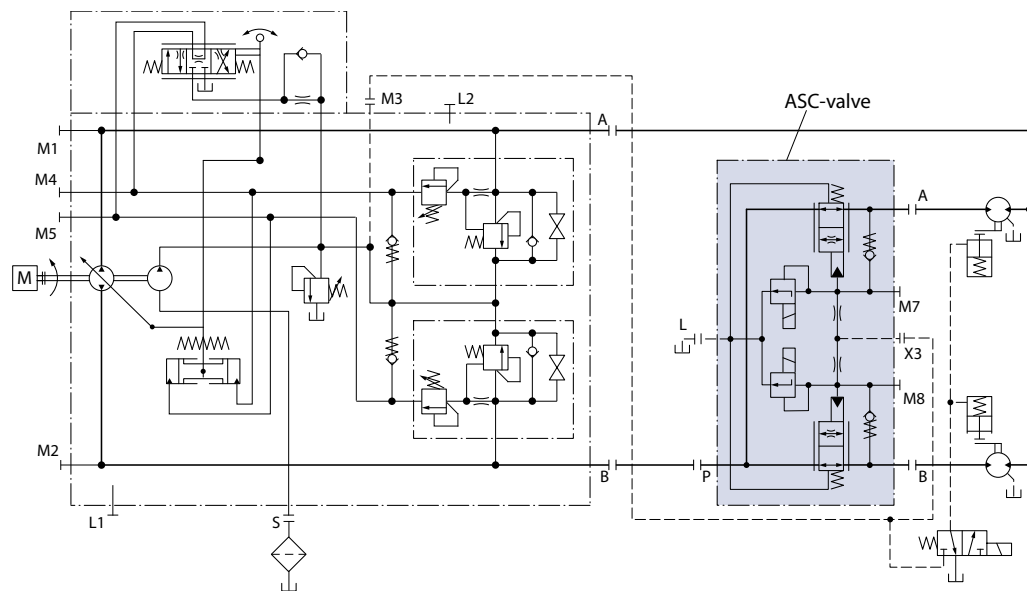

P001 970

**Ports:**

A, B = Main pressure ports M4, M5 = Gauge port - servo pressure

S = Suction port - charge pump M7, M8 = Gauge port - control pressure

L, L1, L2 = Case drain X3 = Control pressure supply port

M1, M2 = Gauge port for A and B

M3 = Gauge port - charge pressure

Above schematics show the function of a hydrostatic transmission using a Series 90 Axial Piston Variable Displacement Pump with manual displacement control (MA) and two Fixed Displacement Hydraulic Motors with brakes and brake valve, controlled by an ASC-valve.

## Technical Information Series ASC Anti Spin Control Valve

### Technical specifications

#### General specifications

Most specifications for the ASC-valve are listed below. For definitions of the various specifications, see the related pages in this publication.

General specifications	
Valve type	Electrical proportional two-spool ASC-valve
Installation position	Discretionary
Other system requirements	Circuit overpressure protection, suitable reservoir

Specific Data					
Order number	507 479	507 832	507 831	507 833	518 033
Voltage	12 V <sub>DC</sub>	24 V <sub>DC</sub>	12 V <sub>DC</sub>	24 V <sub>DC</sub>	24 V <sub>DC</sub>
Weight	7.85 kg [17.3 lb]				
Maximum flow (at port P)	120 l/min [32 US gal/min]		60 l/min [16 US gal/min]		
Remaining flow in closed position at 400 bar [5800 psi]	12 l/min [3.2 US gal/min]		< 2 l/min [0.5 US gal/min]		
Case drain ports	1				2
Hydraulic pipe connections	Main pressure ports: SAE flange + SAE straight thread O-ring boss. Remaining port: SAE straight thread O-ring boss.				
Electric connections	AMP Junior Timer, 12 V <sub>DC</sub> + 24 V <sub>DC</sub>				

#### Technical data

##### Case pressure

	bar	[psi]
Maximum pressure	3.0	[44.0]

##### System pressure range

	bar	[psi]
Maximum pressure	480	[7000]

##### Control pressure

	bar	[psi]
Minimum control supply pressure (X3)	20	[290]
Maximum control supply pressure (X3)	30	[435]

##### Operating current

	12 V <sub>DC</sub>	24 V <sub>DC</sub>
Standby current	300 mA	150 mA
Required max. current	1200-1300 mA	600-650 mA



**Technical specifications**
**Fluid specifications**
*Temperature range\**

	°C	[°F]	
Minimum	-40	[-40]	intermittent, cold start
Rated	104	[220]	
Maximum	115	[240]	intermittent

\* At the hottest point, normally the case drain port.

*Viscosity*

	mm <sup>2</sup> /s	[SUS]	
Minimum	7	[49]	intermittent
Recommended operating range	12-80	[70-370]	
Maximum	1600	[7500]	intermittent cold start

<b>Cleanliness Level and <math>\beta_x</math>-Ratio</b>	
Required fluid cleanliness level	ISO 4406 Class 22/18/13
Recommended $\beta_x$ -ratio for suction filtration	$\beta_{35-45}=75$ ( $\beta_{10} \geq 2$ )
Recommended $\beta_x$ -ratio for charge pressure filtration	$\beta_{15-20}=75$ ( $\beta_{10} \geq 10$ )
Recommended inlet screen size for charge pressure filtration	100 mm-125 mm

## General Technical Specifications

### Pressure Limits

System pressure is the dominant operating variable affecting hydraulic unit life. High pressure, which results from high load, reduces expected life in a manner similar to the affects of high load on other mechanical assemblies such as engines and gear boxes.

Continuous pressure is the pressure at which the hydrostatic system could operate continuously and still achieve acceptable hydrostatic life. This pressure level varies depending on operating speed, and on the life requirements for a particular application. While most mobile applications require system pressure to vary widely during operation, a “weighted average” pressure can be derived from a machine duty cycle. (A duty cycle is a means of quantifying the pressure and speed demands of a particular system on a percent time basis). Once a duty cycle has been determined or estimated for a specific application, contact your Danfoss representative for system life ratings for the application.

*Maximum pressure* is the highest intermittent pressure allowed, and is the relief valve setting. It is determined by the maximum machine load demand. For most systems, the load should move at this pressure.

Maximum pressure is assumed to occur a small percentage of operating time, usually less than 2% of the total. Both the continuous and maximum pressure limits must be satisfied to achieve the expected life.

System Pressure Range	
	bar    [psi]
Maximum pressure	480    [7000]

### Hydraulic Fluids

Ratings and data are based on operating with hydraulic fluids containing oxidation, rust and foam inhibitors. These fluids must possess good thermal and hydrolytic stability to prevent wear, erosion and corrosion of the internal components.

Fire resistant fluids are also suitable at modified operating conditions. Please see Danfoss literature Hydraulic Fluids and Lubricants Technical Information for more information.

It is not permissible to mix hydraulic fluids. For more information contact your Danfoss representative.

The following hydraulic fluids are suitable:

- Hydraulic Oil ISO 11 158 - HM (Seal compatibility and vane pump wear resistance per DIN 51 524-2 must be met)
- Hydraulic Oil ISO 11 158 - HV (Seal compatibility and vane pump wear resistance per DIN 51 524-3 must be met)
- Hydraulic Oil DIN 51 524-2 - HLP
- Hydraulic Oil DIN 51 524-3 - HVLP
- Automatic Transmission Fluid ATF A Suffix A (GM)
- Automatic Transmission Fluid Dexron II (GM), which meets Allison C-3 and Catapillar TO-2 test
- Automatic transmission Fluid M2C33F and G (Ford)
- Engine Oils API Classification CD, SE and SF
- Super Tractor Oil Universal (STOU) special agricultural tractor fluid

### Temperature and Viscosity

Temperature and viscosity requirements must be concurrently satisfied. The data shown in the tables assume petroleum-based fluids are used.

The high temperature limits apply at the hottest point in the transmission, which is normally the case drain. The system should generally be run at or below the *rated temperature*. The *maximum temperature* is based on material properties and should never be exceeded.

## General Technical Specifications

Cold oil will generally not affect the durability of the transmission components, but it may affect the ability to flow oil and transmit power; therefore temperatures should remain 16 °C [30 °F] above the pour point of the hydraulic fluid. The *minimum temperature* relates to the physical properties of component materials.

For maximum unit efficiency the fluid viscosity should remain in the *recommended operating range*. The *minimum viscosity* should be encountered only during brief occasions of maximum ambient temperature and severe duty cycle operation. The *maximum viscosity* should be encountered only at cold start.

Heat exchangers should be sized to keep the fluid within these limits. Testing to verify that these temperature limits are not exceeded is recommended.

Temperature Range <sup>1)</sup>			
	°C	[°F]	
Minimum	-40	[-40]	intermittent, cold start
Rated	104	[220]	
Maximum	115	[240]	intermittent

<sup>1)</sup> At the hottest point, normally the case drain port.

Viscosity		
	mm <sup>2</sup> /s	[SUS]
Minimum	7	[49]
Recommended operating range	12-80	[70-370]
Maximum	1600	[7500]

## Fluid and Filtration

To prevent premature wear, it is imperative that only clean fluid enter the hydrostatic transmission circuit. A filter capable of controlling the fluid cleanliness to ISO 4406 Class 22/18/13 or better under normal operating conditions is recommended.

The filter may be located either on the inlet (suction filtration) or discharge (charge pressure filtration) side of the charge pump. The selected filtration system must maintain a cleanliness level of 22/18/13 per ISO 4406.

The selection of a filter depends on a number of factors including the contaminant ingress rate, the generation of contaminants in the system, the required fluid cleanliness, and the desired maintenance interval. Filters are selected to meet the above requirements using rating parameters of efficiency and capacity.

Filter efficiency may be measured with a Beta ratio<sup>1)</sup> ( $\beta_x$ ). For simple suction-filtered closed circuit transmissions and open circuit transmissions with return line filtration,

a filter with a  $\beta$ -ratio within the range of  $\beta_{35-45} = 75$  ( $\beta_{10} \geq 2$ ) or better has been found to be satisfactory. For some open circuit systems, and closed circuits with cylinders being supplied from the same reservoir, a considerably higher filter efficiency is recommended. This also applies to systems with gears or clutches using a common reservoir. For these systems, a charge pressure or return filtration system with a filter  $\beta$ -rotation in the range of  $\beta_{15-20} = 75$  ( $\beta_{10} \geq 10$ ) or better is typically required.

Since each system is unique, the filtration requirement for that system will be unique and must be determined by test in each case. It is essential that monitoring of prototypes and evaluation of components and performance throughout the test program be the final criteria for judging the adequacy of the filtration system.

Please see Danfoss literature Hydraulic Fluids and Lubricants Technical Information for more information.

<sup>1)</sup> Filter  $\beta_x$ -ratio is a measure of filter efficiency defined by ISO 4572. It is defined as the ratio of the number of particles greater than a given diameter ("x" in  $\mu\text{m}$ ) upstream of the filter to the number of these particles downstream of the filter.

**General Technical Specifications**

<b>Cleanliness Level and <math>\beta_x</math>-Ratio</b>	
Required fluid cleanliness level	ISO 4406 Class 22/18/13
Recommended $\beta_x$ -ratio for suction filtration	$\beta_{35-45}=75$ ( $\beta_{10} \geq 2$ )
Recommended $\beta_x$ -ratio for charge pressure filtration	$\beta_{15-20}=75$ ( $\beta_{10} \geq 10$ )
Recommended inlet screen size for charge pressure filtration	100 $\mu\text{m}$ -125 $\mu\text{m}$

**Independent Braking System**
 **Warning**

---

The loss of hydrostatic drive line power in any mode of operation (e.g., forward, reverse, or “neutral” mode) may cause the loss of hydrostatic braking capacity. A braking system, redundant to the hydrostatic transmission must, therefore, be provided which is adequate to stop and hold the system should the condition develop.

---

**Reservoir**

The function of the reservoir is to remove air and to provide make up fluid for volume changes associated with fluid expansion or contraction, possible cylinder flow, and minor leakage.

The reservoir should be designed to accommodate maximum volume changes during all system operating modes and to promote deaeration of the fluid as it passes through the tank.

A minimum reservoir volume equal to 1/2 to 1 1/2 times charge pump flow/min is suggested. This allows 30 seconds fluid dwell for removing entrained air at the maximum return flow. This is usually adequate to allow for a closed reservoir (no breather) in most applications. The reservoir outlet to the charge pump inlet should be above the bottom of the reservoir to take advantage of gravity separation and prevent large foreign particles from entering the charge inlet line.

The reservoir inlet (fluid return) should be positioned so that the flow to the reservoir is discharged below the normal fluid level, and also directed into the interior of the reservoir for maximum dwell and efficient deaeration.

**Functional Description**

**General Description**

The ASC-valve is used in anti slip systems for hydrostatic drive systems. It is possible to use this valve in wheeled machines with up to 4 wheels driven individually. The ASC System is especially useful for applications with fixed motors, but can also be combined with variable displacement motors.

The ASC System consists of a central digital controller Susmic S1X, speed sensors for each motor, the ASC-valve and steering sensors. It is important to note that in such system the amount of impulses per wheel rotation should show the highest possible frequency resolution in order to be able to ensure a good performance of the anti slip system.

**ASC-Valve function**

The ASC-valve is of twin valve design and provides both motors with the required flow, generally these are the 2 motors for one axle not mechanical connected. The input flow in P is divided and equally ported to port A and B (see P001 968).

*ASC-valve in neutral, no wheel slips*

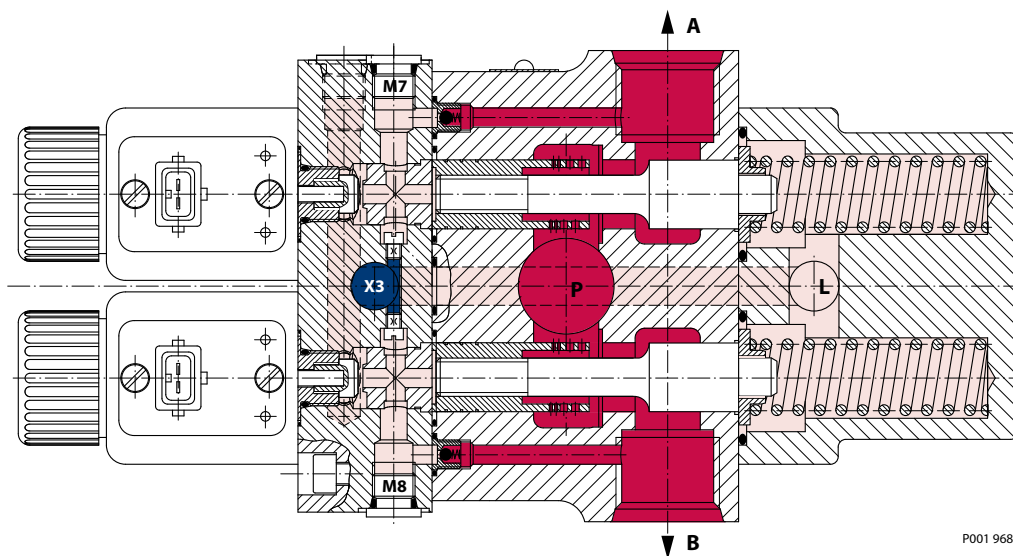

P001 968

If for example the wheel connected to port "B" slips, the speed sensor detects this and sends a signal to the Susmic S1X controller. The Susmic S1X controller then will provide current to the electric proportional valve for port "B" and the spool in the ASC-valve closes the connection to port "B", so a pressure drop across this connection is build up equal to the pressure of the other wheel connected to port "A" minus the pressure needed to drive wheel "B" (see P001 980). This limits the flow to wheel "B" and the wheel stops to slip and runs at the same speed as the wheel connected to port "A"

Functional Description

*Wheel connected to port "B" slips, spool "B" 2/3 closed*

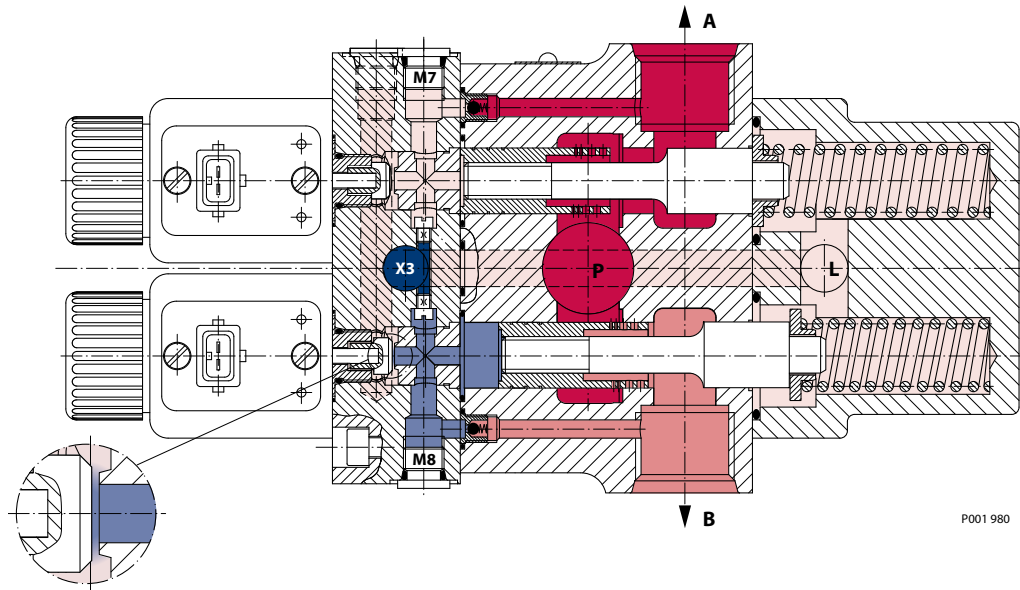

If under extreme conditions and low speeds the wheel connected to port "B" continues to slip, spool "B" will close completely and only the "remaining flow" will flow to port "B" (see P001 995).

*Wheel connected to port "B" at max slip, spool "B" completely closed.*

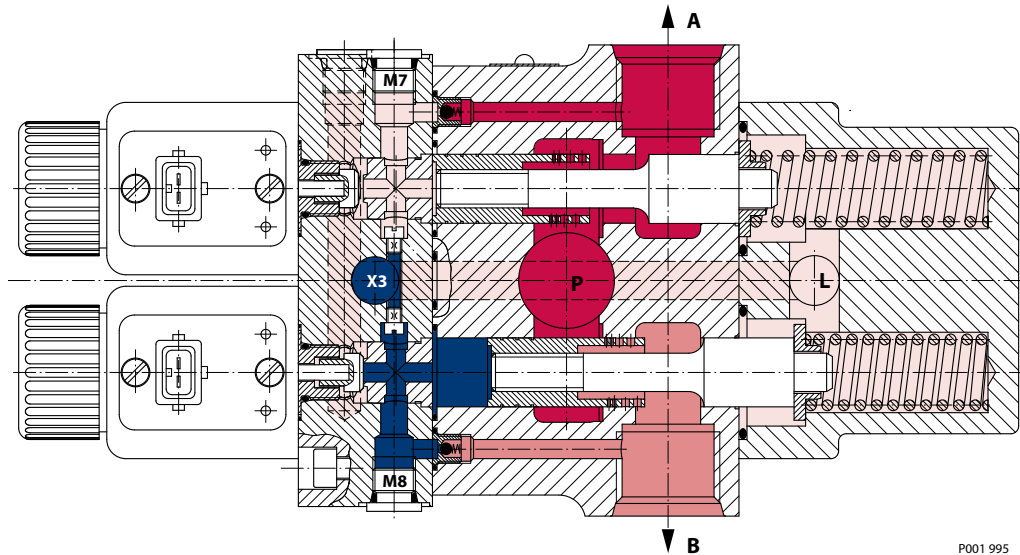

### Application Considerations

The following measures must be considered for proper anti spin function:

- Remaining flow from the ASC-valve at maximum input current limits the minimum motor speed (possible remaining motor slip).
- Additional pressure limiter may be required if valve with low remaining flow at maximum input current is used and valve is arranged in the return line of the motor.
- When using more than one ASC-valve in an application either all valves must be placed in the supply line of all motors or all valves must be placed in the return line of all motors.
- Sum pressure for motors at downhill and deceleration condition must be considered.
- Integrated loop flushing is not allowed because of potential sum pressure condition (high pressure hydraulic fluid would be flushed out).

Availability

Available Options

Typical ASC-valves with order numbers 507 479 (12 V<sub>DC</sub>) or 507 832 (24 V<sub>DC</sub>) with a remaining flow of 12 l/min [3.17 US gal/min] are used. These valves meet most application requirements. Please note, that due to the 12 l/min [3.17 US gal/min] remaining flow at 400 bar [5800 psi] the spinning wheel cannot be completely stoped.

If it is required that wheel slip is near zero at max closed position, the ASC-valves with a remaining flow of < 2 l/min [0.5 US gal/min] at 400 bar [5800 psi] are recommended. Order numbers for such valves are 507 831 (12 V<sub>DC</sub>) or 507 833 (24 V<sub>DC</sub>) for a maximum flow of 60 l/min [16 US gal/min]. However, high sum pressure risk at downhill condition is higher.

In some cases it may be demanded, that the ASC-valve remains in max closed position, if voltage/current supply is lost. This is typically the case if the emergency stop button is hit. The ASC-valve with order number 518 033 (24 V<sub>DC</sub>), 60 l/min [16 US gal/min] and remaining flow of < 2 l/min [0.5 US gal/min] at 400 bar [5800 psi] provides a separat LX port.

Scematic ASC-valve 518 033

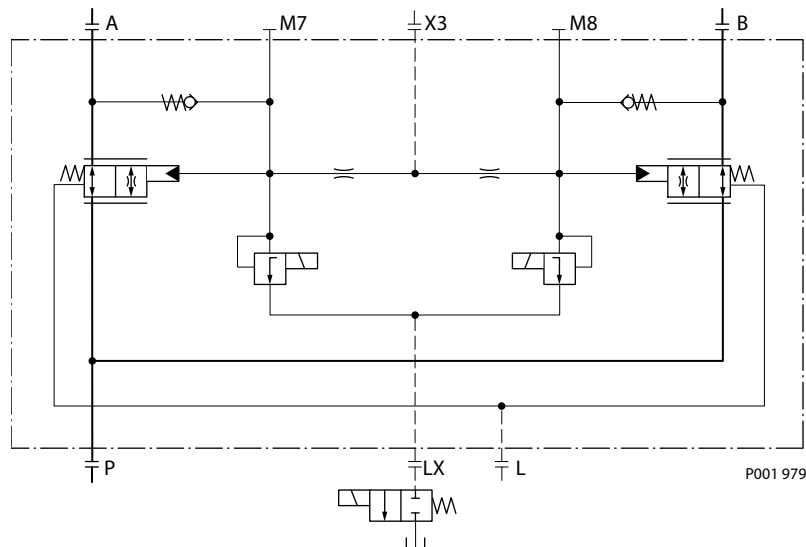

In order to hold the ASC-valve in closed position this LX port may be closed by a solenoid valve which is closed when not activated. This maintains the pressure acting on the main spool and keeps it closed. Please note, that this causes the other spool to close as well. Carefully check the impact on the application.



**Technical data**

**Pressure drop**

The pressure drop versus flow at normal condition (anti spin function not active) from P to A respectively from P to B and reverse is shown in below diagram at a viscosity of 28 mm<sup>2</sup>/s [70 SUS]. The flow entered in P is divided equally and ported to A and B.

*Pressure drop versus flow*

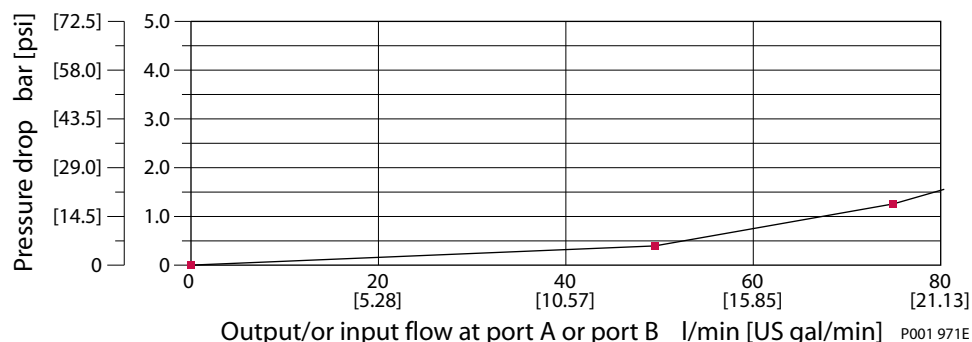

**Remaining flow at maximum closed position**

Although the ASC-valve is in maximum closed position (anti spin function is activated and running at max slip condition) a remaining flow will allow the spinning wheel to slip. The remaining flow from P to A respectively from P to B is shown in below diagrams at a viscosity of 28 mm<sup>2</sup>/s [70 SUS].

*Remaining flow versus differential pressure for 507479 and 507832*

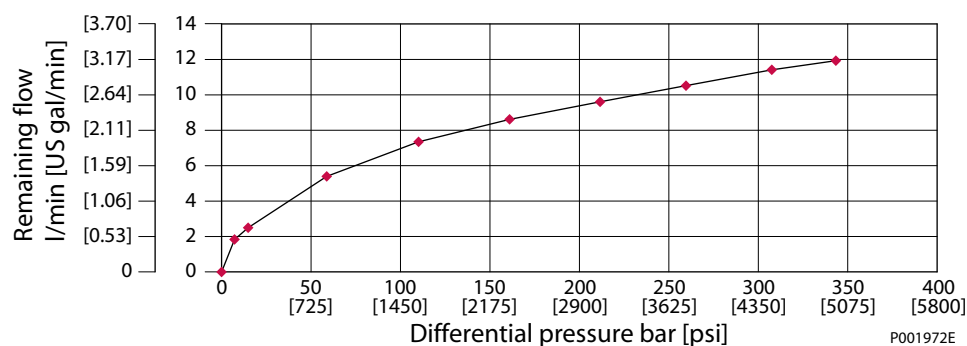

*Remaining flow versus differential pressure for 507831, 507833 and 518033*

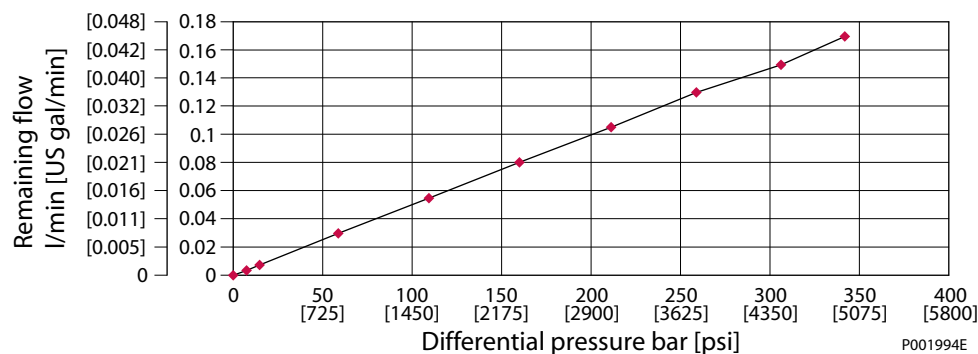

**Technical data**

**Spool stroke versus current**

Due to tolerance stack up the spool may start to close (start to shut off one motor) already at 200 mA or may need 300 mA (24 V<sub>DC</sub> option). To make sure the valve is securely open when the anti spin function is not needed, the standby current has to be limited to 300 mA for 12 V<sub>DC</sub> and 150 mA for 24 V<sub>DC</sub>.

These tolerances furthermore have an impact on the maximum spool closing position. The valve may need 650 mA for 24 V<sub>DC</sub> respectively 1300 mA for 12 V<sub>DC</sub> to be at maximum closed position.

*ASC-valve spool stroke versus current (all 12 V<sub>DC</sub> options)*

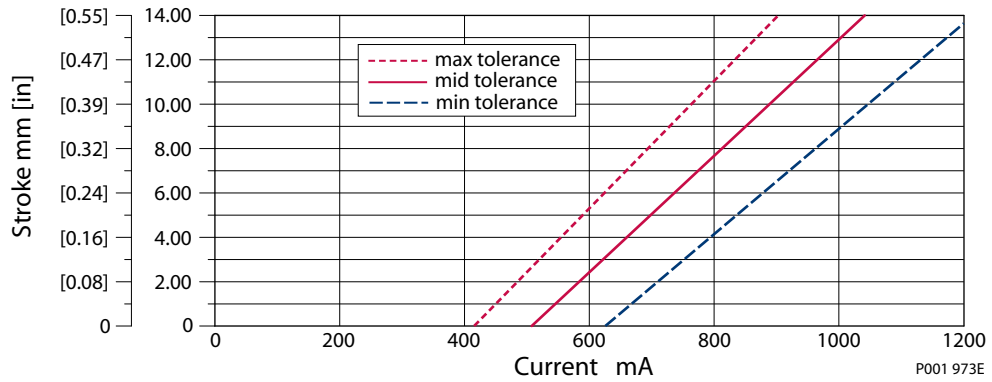

*ASC-valve spool stroke versus current (all 24 V<sub>DC</sub> options)*

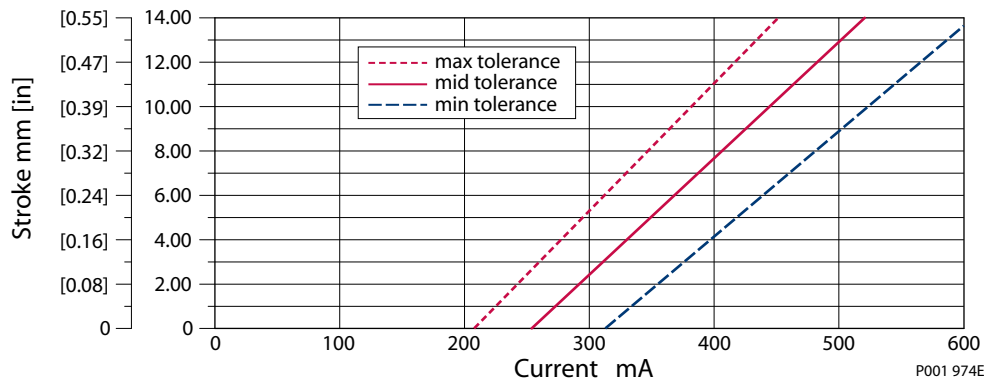

Outline Dimensions

ASC-valves 507479, 507832, 507831, 507833

mm  
[in]

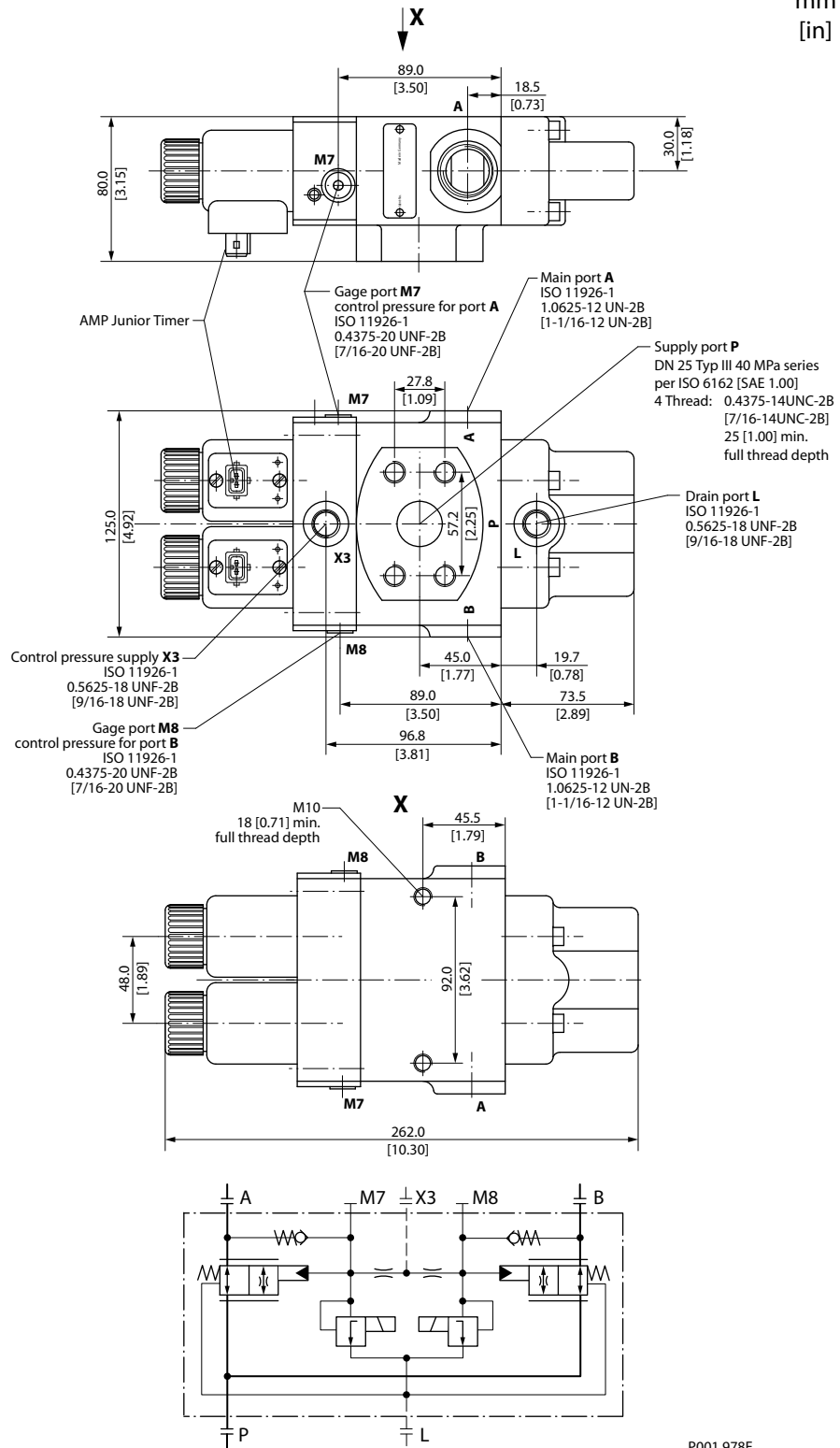

P001 978E

Contact your Danfoss representative for specific installation drawings.

Outline Dimensions

ASC-valve 518033 with 2 case drain ports

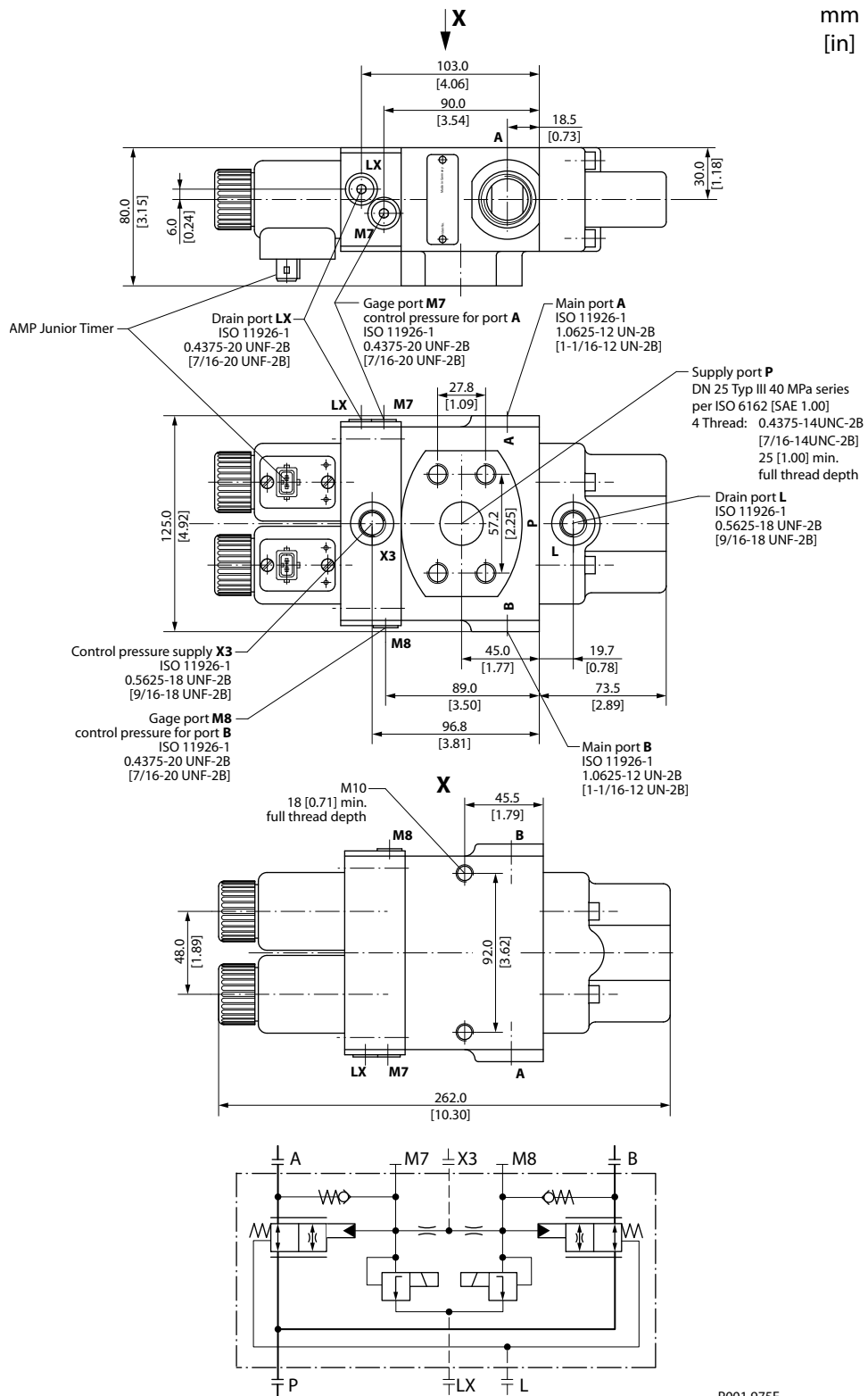

Contact your Danfoss representative for specific installation drawings.









**Products we offer:**

- Bent Axis Motors
- Closed Circuit Axial Piston Pumps and Motors
- Displays
- Electrohydraulic Power Steering
- Electrohydraulics
- Hydraulic Power Steering
- Integrated Systems
- Joysticks and Control Handles
- Microcontrollers and Software
- Open Circuit Axial Piston Pumps
- Orbital Motors
- PLUS+1® GUIDE
- Proportional Valves
- Sensors
- Steering
- Transit Mixer Drives

**Danfoss Power Solutions** is a global manufacturer and supplier of high-quality hydraulic and electronic components. We specialize in providing state-of-the-art technology and solutions that excel in the harsh operating conditions of the mobile off-highway market. Building on our extensive applications expertise, we work closely with our customers to ensure exceptional performance for a broad range of off-highway vehicles.

We help OEMs around the world speed up system development, reduce costs and bring vehicles to market faster.

Danfoss – Your Strongest Partner in Mobile Hydraulics.

**Go to [www.powersolutions.danfoss.com](http://www.powersolutions.danfoss.com) for further product information.**

Wherever off-highway vehicles are at work, so is Danfoss. We offer expert worldwide support for our customers, ensuring the best possible solutions for outstanding performance. And with an extensive network of Global Service Partners, we also provide comprehensive global service for all of our components.

Please contact the Danfoss Power Solution representative nearest you.

**Comatrol**

[www.comatrol.com](http://www.comatrol.com)

**Schwarzmueller-Inverter**

[www.schwarzmueller-inverter.com](http://www.schwarzmueller-inverter.com)

**Turolla**

[www.turollaocg.com](http://www.turollaocg.com)

**Valmova**

[www.valmova.com](http://www.valmova.com)

**Hydro-Gear**

[www.hydro-gear.com](http://www.hydro-gear.com)

**Daikin-Sauer-Danfoss**

[www.daikin-sauer-danfoss.com](http://www.daikin-sauer-danfoss.com)

Local address:

**Danfoss Power Solutions US Company**  
2800 East 13th Street  
Ames, IA 50010, USA  
Phone: +1 515 239 6000

**Danfoss Power Solutions GmbH & Co. OHG**  
Krokamp 35  
D-24539 Neumünster, Germany  
Phone: +49 4321 871 0

**Danfoss Power Solutions ApS**  
Nordborgvej 81  
DK-6430 Nordborg, Denmark  
Phone: +45 7488 2222

**Danfoss Power Solutions (Shanghai) Co., Ltd.**  
Building #22, No. 1000 Jin Hai Rd  
Jin Qiao, Pudong New District  
Shanghai, China 201206  
Phone: +86 21 3418 5200

Danfoss can accept no responsibility for possible errors in catalogues, brochures and other printed material. Danfoss reserves the right to alter its products without notice. This also applies to products already on order provided that such alterations can be made without changes being necessary in specifications already agreed. All trademarks in this material are property of the respective companies. Danfoss and the Danfoss logotype are trademarks of Danfoss A/S. All rights reserved.