



SMITH-COOPER.
INTERNATIONAL

Anvil International & Smith-Cooper International Revit Content Guide

The purpose of this document is to assist Revit users utilize Anvil's hanger assembly content to its full potential. Please note that not every assembly, configuration, or selection will be covered here. However, this document will be a useful tool for getting started, and/or troubleshooting different configurations of Anvil's hanger assemblies within a Revit project.

Table of Contents

<i>GENERAL INFORMATION</i>	2
<i>ANVIL CONTENT OVERVIEW</i>	2
<i>PLACING FAMILIES INTO REVIT PROJECTS</i>	2
<i>REVIT FAMILY/TYPE NAME CONVENTION</i>	2
<i>PARAMETER GROUP BREAKDOWN</i>	4
<i>PLUMBING GROUP</i>	4
<i>DIMENSIONS GROUP</i>	5
<i>CONSTRUCTION GROUP</i>	8
<i>MATERIALS AND FINISHES GROUP</i>	9
<i>GRAPHICS GROUP</i>	10
<i>USER INPUT</i>	11
<i>USER-DEFINED ENTRIES</i>	11
<i>ASSEMBLY – SPECIFIC COMMENTS</i>	16
<i>HANGER-CLEVIS-ANVIL-260_290_66_TURNBUCKLE</i>	16
<i>PIPE_ROLL_STAND-ANVIL-177_SUPPORT</i>	18
<i>ADDITIONAL RESOURCES</i>	21
<i>LINK TO ANVIL’S WEBSITE</i>	21
<i>LINK TO ANVIL’S HANGER CONTENT</i>	21
<i>LINK TO ANVIL’S BIM PORTAL</i>	21
<i>LINK TO ENGWORKS WEBSITE</i>	21

General Information

Anvil Content Overview

- Most of the assemblies are built to allow for various component configurations within a range of pipe sizes, and/or maximum loading ratings.
- Most assemblies will allow the user to enter invalid component dimensions. This was done to prevent the assemblies from “breaking” within a project, as this can slow down a project’s production.
- Rather than the family “breaking” within a project, a text parameter will display an error message to the user within the properties window.
 - If a warning message appears, the user should verify all of the component selections within the assembly are in fact valid.
 - This is best accomplished by referencing the components’ submittal pdfs on Anvil’s website.
 - Examples of these warning messages can be found in the Parameter Group Breakdown section.

Placing Families into Revit Projects

- There are no accompanying Type Catalogs to load for these assemblies. Most of the customization is handled by the user within Revit’s user interface.
 - This allows users to “Drag and Drop” the families from a folder directly into an active project.
 - This eliminates the need to keep track of external data files.
- It is recommended that the user places the desired assembly into an active floor plan view since this guarantees the assembly is placed on the desired Revit level without an offset.
- For additional information, please reference the Dimensions Group section.

Revit Family/Type Name Convention

- The general Revit Family naming convention is as follows:
 1. The general style of the pipe support assembly (Hanger or Pipe Roll Stand).
 2. A description of the device which grabs/supports the pipe (Clevis, Pipe Clamp, Steel Yoke Pipe Roll, Swivel Ring, Trapeze).
 3. Manufacturer Name (Anvil).
 4. List of components that make up the assembly** (separated by underscore).
 - **Please note that not every component will be listed in the assembly family’s name.** This is a general guide based on Anvil’s 2D assembly drawings.
 - Ex) The “Hanger-Pipe_Clamp-Anvil-212_290” Family actually contains options for the following components: **Fig. 212, Fig. 216, Fig. 60, Fig. 290, Fig. 140, Fig. 146.**
- The Revit Type name convention is primarily based on the maximum load provided in the Clevis Hanger, Pipe Clamp, Swivel Ring Adapter, or Pipe Roll submittals. This value is followed by the range of nominal pipe sizes available for that device.
 - The type name convention only serves as a general guide to help users narrow down the assemblies that are suitable for their project’s needs.
 - The type names should **not** be used in place of professional structural analysis.

- Another type name convention can be found for assemblies that use either the **Fig. 228 Universal Forged Steel Beam Clamp**, or the **Fig. 292 UFS Beam Clamp w/ Weldless Eye Nut**. Each type will specify the maximum load rating for the clamp size. The type names resemble the charts found in their respective submittals (see comparison of submittal charts and Revit Type names below).
 - For the **Fig. 228** beam clamp, there is a maximum load rating based on the beam clamp number (not listed in the type name) as well as the link furnishing option.
 - As for the **Fig. 292** beam clamp, there are a few more options found in the submittal. To better distinguish the selections for the end-user, the naming is similar to the **Fig. 228** beam clamp, but with the addition of the beam clamp number (please reference the images below).

FIG. 228: DIMENSIONS (IN) • LOADS (LBS) • WEIGHT (LBS)

Clamp Size No.	Max Rod Size A	Max Load ■	Weight	Z Max ❖	B	Jaw and Nut Size ▲
1	5/8	2,160	3.3	0.60	1 1/8	228 - 1
2	3/4	4,480	7.0		1 1/4	228 - 2
3 •		10.6	1.031	2 3/8	228 - 3	
4	11,500	19.3				
5 •	31.0					

Example 1: Image of Fig. 228 chart found in the submittal.

Hanger-Clevis-Anvil-260_228

- Max Load_2,160 Lbs - Furnished without Links
- Max Load_4,480 Lbs - Furnished with Links
- Max Load_4,480 Lbs - Furnished without Links
- Max Load_11,500 Lbs - Furnished with Links
- Max Load_11,500 Lbs - Furnished without Links

Example 2: Type Names for families using the Fig. 228 Beam Clamp.

FIG. 292, FIG. 292L: DIMENSIONS (IN) • LOADS (LBS) • WEIGHT (LBS)

Clamp Size No.	Max Rod Size A	Max Load ■	Weight	Z Max ❖	B	Jaw and Eye Nut Size ▲
1	3/4	3,230	3.9	0.60	1 1/8	292 - 1 / 1
2			9.2		1	292 - 2 / 2
3 •			13.0			292 - 3 / 2
4			21.7			
5 •	33.9	11,500	1.031	1 1/4	292 - 3 / 3	
6	23.9					
7 •	35.8					
8	2		36.8		2 1/4	292 - 3 / 4

Example 3: Image of Fig. 292 chart found in the submittal.

Hanger-Pipe_Clamp-Anvil-212_290_292

- Max Load_3,230 Lbs - Furnished without Links - Clamp No. 1
- Max Load_5,900 Lbs - Furnished with Links - Clamp No. 3
- Max Load_5,900 Lbs - Furnished with Links - Clamp No. 5
- Max Load_5,900 Lbs - Furnished without Links - Clamp No. 2
- Max Load_5,900 Lbs - Furnished without Links - Clamp No. 4
- Max Load_11,500 Lbs - Furnished with Links - Clamp No. 7
- Max Load_11,500 Lbs - Furnished without Links - Clamp No. 6
- Max Load_11,500 Lbs - Furnished without Links - Clamp No. 8

Example 4: Type Names for families using the Fig. 292 Beam Clamp.

Parameter Group Breakdown

Plumbing Group

- This is where the user will enter their desired *Nominal Pipe Size*.
- Most of the assemblies will also report the size of the device that is holding/supporting the pipe. These values may not always be the same (such as when insulation is being used, or oversized rollers are implemented, etc....).
- Typically, the user will see a range of hanger device sizes available per the Nominal Pipe Size (and/or *Insulation Size*) that is selected.
 - If the given device's size is unavailable, the user will be prompted with a warning message in the properties window.
 - The warning message parameter will be blank if all necessary design criteria have been satisfied.
 - If the design requirements for a given component are not met, a message will appear in ALL CAPS to inform the user that an adjustment is required.
 - Warning parameters will always appear above the device's current size or material selection. Lastly, these parameters will always begin with "X" in the parameter name. (refer to images below for examples).

Plumbing	
X Swivel Ring Warning	
+ Maximum Allowable Swivel Ring Size	8"
- Minimum Allowable Swivel Ring Size	1/2"
Swivel Ring Size	1/2"
Nominal Pipe Size	1/2"
Nominal Pipe Radius	1/4"

Example 5: Proper Swivel Ring Selection within an assembly family.

Plumbing	
X Swivel Ring Warning	SWIVEL RING SIZE UNAVAILABLE
+ Maximum Allowable Swivel Ring Size	8"
- Minimum Allowable Swivel Ring Size	1/2"
Swivel Ring Size	8"
Nominal Pipe Size	10"
Nominal Pipe Radius	5"

Example 6: Warning message notifying the user that the Swivel Ring component's design requirements are not satisfied.

Dimensions Group

- This is where the user will enter values for the following:
 - **Pipe Center Elevation**
 - Measurement from a level's base to the center of the pipe.
 - Most of the assemblies will have a default *Pipe Center Elevation* of **6 or 8 feet**.
 - The assemblies with a *Pipe Center Elevation* of **6 feet** were built this way to accommodate large clevis sizes, and ultimately prevent the assembly from breaking within a project.
 - Some Pipe Roll assemblies will have a *Pipe Center Elevation* greater than the *Structure Height*. This is due to the roller being mounted on the upper surface of a beam or structural support.
 - The user may also choose to use the “Grips” within an elevation view and drag the assembly to an existing pipe segment’s elevation.
 - **Structure Height**
 - Each assembly will have a default *Structure Height* of **10 feet** (dimensioned from Revit’s reference level to the assembly’s mounting surface elevation).
 - The user may also choose to use the “Grips” within an elevation view and drag the assembly to the desired location.
 - **Rod Extension Length**
 - Some contractors will have requirements for how much additional, or excess, threaded rod is used when going into a structure.
 - For the assemblies that have this option, the user can enter the desired length to meet the project’s requirements.
 - Some assemblies have a maximum acceptable value for the *Rod Extension Length* (assemblies with **Fig. 218, Fig. 228, Fig. 292**).
 - A warning message will be triggered if the user happens to exceed this value.

Dimensions	
Pipe Center Elevation	6' 0"
Structure Height	10' 0"
Pipe Center to Clamp Offset	4' 0"
Size	

Example 7: Pipe Center Elevation parameter, and the measurement within a Revit Project (right).

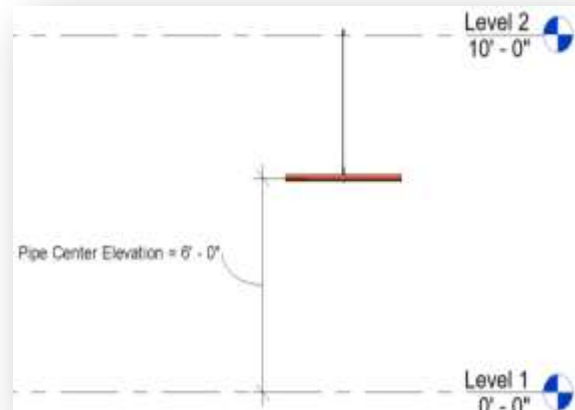

Dimensions	
Pipe Center Elevation	6' 0"
Structure Height	10' 0"
Pipe Center to Clamp Offset	4' 0"
Size	

Example 8: Structure Height parameter, and the measurement within a Revit project.

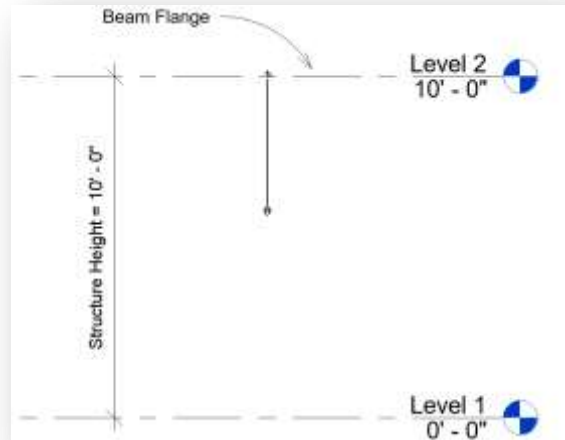

Dimensions	
Pipe Center Elevation	6' 0"
Structure Height	10' 0"
Rod Extension Length	0' 1 3/4"
Pipe Center to Washer Plate	4' 0"
Size	

Example 9: Rod Extension Length parameter, and an example measurement within a Revit project (assembly with Fig. 60 Washer Plate).

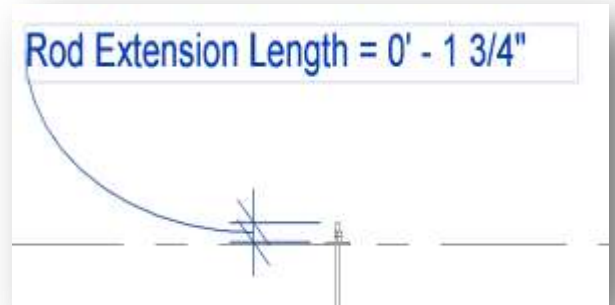

Dimensions	
✘ Rod Extension Length Warning	
Maximum Rod Extension	0' 0 17/32"
Rod Extension Length	0' 1"
Pipe Center Elevation	8' 0"
Structure Height	10' 0"
Pipe Center to Beam	2' 0"
Size	

Example 10: Warning message displayed when the user exceeds the Maximum Rod Extension value.

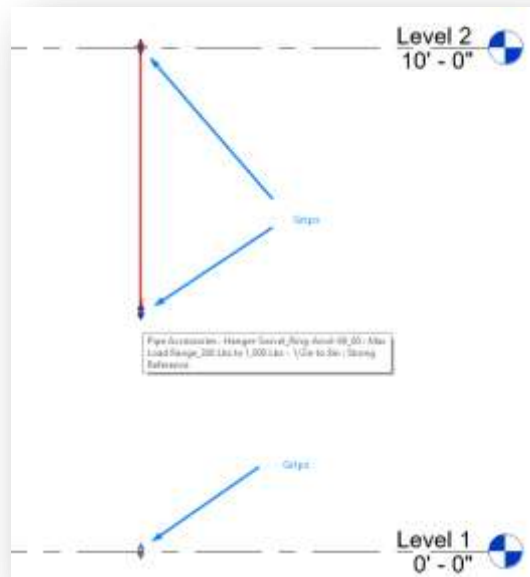

Example 11: "Grips" within a Revit Project. They will appear as 2 arrows indicating the direction of motion (linear).

Construction Group

- This is where most of the component design options are located. In addition to the selectors, there may be additional component information found here (e.g., *Hanger Rod Diameter*).
- Some assemblies will allow the user to swap out different components as well.
 - Ex) Selecting between Beam Clamps (**Fig. 92 to Fig. 93**).
 - Ex) Selecting between Concrete Inserts (**Fig. 281, Fig. 282, Fig. 285**).
- As mentioned previously, most of the selectors will not allow the user to “break” the assembly. This is done by defaulting to either the component’s smallest or largest size, and then triggering a warning message above that component’s selector.



Example 12: Insulation size and Threaded rod size selectors.

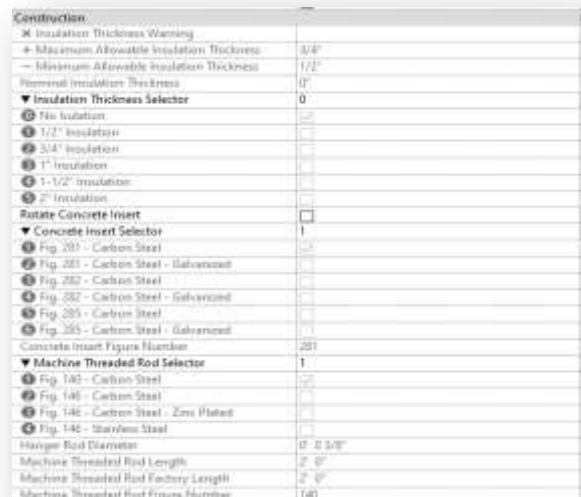

Example 13: More Construction Group parameters.

Materials and Finishes Group

- If a component has multiple finishes available, this is where the user will specify the desired finish.
- These changes typically do not influence the assembly’s geometry, but this will influence the part numbers populated within a BOM (Bill of Materials).
- There are some components that have different sizes available in one finish than another finish.
 - A prime example of this is the **Fig. 260 Clevis Hanger**. The **zinc plated** and **galvanized** finishes have a different range of sizes available compared to the other finishes.
 - In the case that the user chooses an invalid pipe size and material finish selection, the user will be prompted with a warning message reading “CLEVIS FINISH UNAVAILABLE”.

Materials and Finishes	
▼ Clevis Hanger Finish Selector	1
① Fig. 65 - Carbon Steel	<input checked="" type="checkbox"/>
② Fig. 65 - Carbon Steel - Zinc Plated	<input type="checkbox"/>
Clevis Hanger Material	Carbon Steel
▼ Beam Clamp Finish Selector	1
① Fig. 86 - Malleable Iron	<input checked="" type="checkbox"/>
② Fig. 86 - Malleable Iron - Zinc Plated	<input type="checkbox"/>
Beam Clamp Material	Malleable Iron - Plain
Machine Threaded Rod Material	Carbon Steel

Example 14: Various Material/Finish Selectors in Revit.

Materials and Finishes	
✖ Clevis Hanger Finish Warning	CLEVIS FINISH UNAVAILABLE
▼ Clevis Hanger Finish Selector	3
① Fig. 200 - Carbon Steel	<input type="checkbox"/>
② Fig. 200 - Carbon Steel - Epoxy Coated	<input type="checkbox"/>
③ Fig. 200 - Carbon Steel - Galvanized	<input checked="" type="checkbox"/>
④ Fig. 200 - Carbon Steel - Plastic	<input type="checkbox"/>
⑤ Fig. 200 - Carbon Steel - Primed	<input type="checkbox"/>
⑥ Fig. 200 - Carbon Steel - Zinc Plated	<input type="checkbox"/>
Clevis Hanger Material	Carbon Steel - Galvanized
▼ Beam Clamp Finish Selector	1
① Fig. 238 - Steel	<input checked="" type="checkbox"/>
② Fig. 238 - Steel - Galvanized	<input type="checkbox"/>
Beam Clamp Material	Steel
Machine Threaded Rod Material	Carbon Steel
Plumbing	
✖ Clevis Size Warning	CLEVIS SIZE UNAVAILABLE
+ Maximum Allowable Clevis Size	30"
- Minimum Allowable Clevis Size	10"
Clevis Hanger Size	10"
Nominal Pipe Size	1/2"
Nominal Pipe Radius	1/4"

Example 15: Warning message example for invalid Clevis Hanger finish selection.

Graphics Group

- The Graphics Parameter group, which is just below the construction group, contains a checkbox that controls the visibility of the clearance graphics in Revit. The default clearance visibility is set to “On”.
- This selection will affect the clearance display in ALL views (plan views, 3D views, etc....).

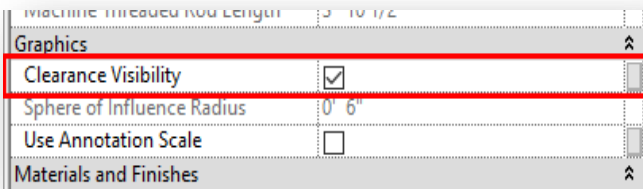

Example 16: Clearance Visibility turned On in Revit.

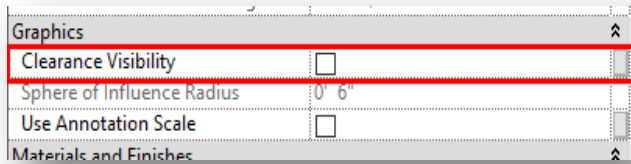

Example 17: Clearance Visibility turned Off in Revit.

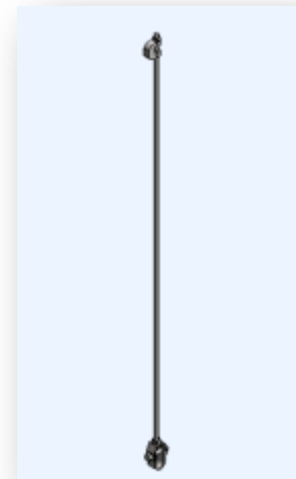

User Input

User-Defined Entries

- For *Pipe Center Elevation*, *Structure Height*, and *Rod Extension Length*, revisit the previous section's *Dimensions Group* examples on how to utilize these parameters.
- **Component Rotation**
 - For some assemblies, the user may need to rotate the structural component. If this functionality is available for an assembly, the user may enter **any** angle value (not just 0, 90, or 180 degrees) to accommodate their project's requirements.
 - Some assemblies will not allow the user to specify an angle other than 90 degrees. In this case, the user will find a checkbox to rotate the component by 90 degrees.

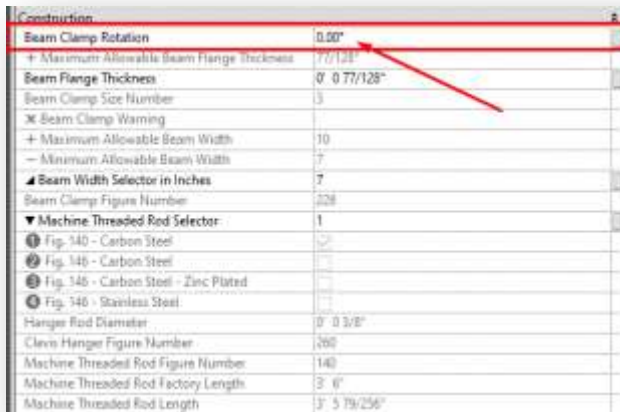

Example 18: Default rotation angle of 0 in Revit.

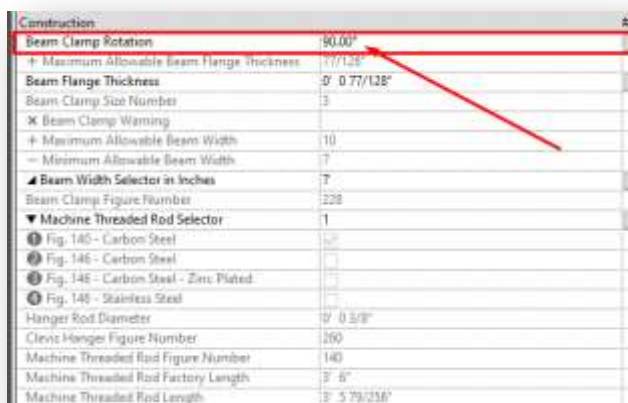

Example 19: Beam Clamp with 90-degree rotation angle in Revit.



Example 20: Default setting for a check-box rotation parameter.

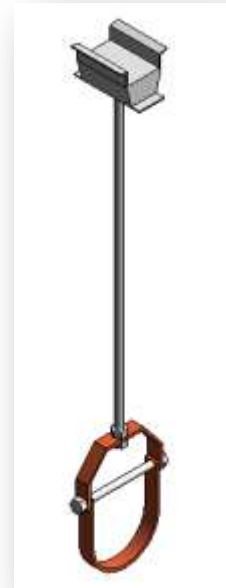

Example 21: Rotating a component with a check-box in Revit.



- **Beam Width Adjustments**

- For assemblies using **Fig. 228** or **Fig. 292**, the user can adjust the beam width using the *Beam Width Selector in Inches* parameter. The user has access to both minimum and maximum allowable values for the given family type. The user will trigger a warning message if the specified beam width falls outside of this range.
- For assemblies using the **Fig. 218** Beam Clamp, the user can adjust the width using the *Beam Width Selector* parameter.

Construction	
Beam Clamp Rotation	0.00°
+ Maximum Allowable Beam Flange Thickness	77/128"
Beam Flange Thickness	0' 0 77/128"
Beam Clamp Size Number	1
✕ Beam Clamp Warning	
+ Maximum Allowable Beam Width	7
- Minimum Allowable Beam Width	3
▲ Beam Width Selector in Inches	3
Beam Clamp Figure Number	228
▼ Machine Threaded Rod Selector	1
Fig. 140 - Carbon Steel	

Example 22: Adjusting Beam Width for Beam Clamps in Revit.

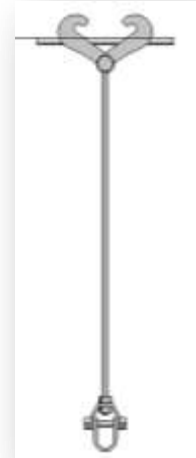

Construction	
Beam Clamp Rotation	0.00°
+ Maximum Allowable Beam Flange Thickness	77/128"
Beam Flange Thickness	0' 0 77/128"
Beam Clamp Size Number	1
✕ Beam Clamp Warning	
+ Maximum Allowable Beam Width	7
- Minimum Allowable Beam Width	3
▲ Beam Width Selector in Inches	5
Beam Clamp Figure Number	228
▼ Machine Threaded Rod Selector	1
Fig. 140 - Carbon Steel	
Fig. 146 - Carbon Steel	

Example 23: Adjusting Beam Width for Beam Clamps in Revit.



Beam Clamp Rotation	0.00°
+ Maximum Allowable Beam Flange Thickness	77/128"
Beam Flange Thickness	0' 0 77/128"
▼ Beam Width Selector	1
1 2-3/8in	<input checked="" type="checkbox"/>
2 3in	<input type="checkbox"/>
3 4in	<input type="checkbox"/>
4 5in	<input type="checkbox"/>
5 6in	<input type="checkbox"/>
6 7in	<input type="checkbox"/>

Example 24: Adjusting Beam Width for Fig. 218 Beam Clamps in Revit.



Beam Clamp Rotation	0.00°
+ Maximum Allowable Beam Flange Thickness	77/128"
Beam Flange Thickness	0' 0 77/128"
▼ Beam Width Selector	5
1 2-3/8in	<input type="checkbox"/>
2 3in	<input type="checkbox"/>
3 4in	<input type="checkbox"/>
4 5in	<input type="checkbox"/>
5 6in	<input checked="" type="checkbox"/>
6 7in	<input type="checkbox"/>

Example 25: Adjusting Beam Width for Fig. 218 Beam Clamps in Revit.



- **Beam Flange Thickness Adjustments**

- The user has the option to adjust the contact point between the beam clamp’s tie-rod and the clamp’s jaws. This is the thickness of the beam flange.
- There is a maximum allowable beam flange thickness defined in the component submittals, and this value can also be referenced within the Construction Parameter Group (see example below).
 - Assemblies that use a beam clamp will have the Maximum Beam Flange Thickness set as the default thickness.
 - If the user exceeds the maximum beam flange thickness, the component’s value will default to the maximum allowable (without a warning message).



Example 26: Maximum Beam Flange Thickness, Z Max, from component submittal.

Construction	
✕ Insulation Thickness Warning	
+ Maximum Allowable Insulation Thickness	3/4"
- Minimum Allowable Insulation Thickness	1/2"
Nominal Insulation Thickness	0"
▼ Insulation Thickness Selector	0
① No Insulation	<input checked="" type="checkbox"/>
② 1/2" Insulation	<input type="checkbox"/>
③ 3/4" Insulation	<input type="checkbox"/>
④ 1" Insulation	<input type="checkbox"/>
⑤ 1-1/2" Insulation	<input type="checkbox"/>
⑥ 2" Insulation	<input type="checkbox"/>
Beam Clamp Rotation	0.00°
+ Maximum Allowable Beam Flange Thickness	77/128"
Beam Flange Thickness	0' 0 77/128"
▼ Beam Width Selector	5
① 2-3/8in	<input type="checkbox"/>
② 3in	<input type="checkbox"/>
③ 4in	<input type="checkbox"/>
④ 5in	<input type="checkbox"/>
⑤ 6in	<input checked="" type="checkbox"/>
⑥ 7in	<input type="checkbox"/>

Example 27: Beam Flange Thickness example in Revit. Notice the Maximum Allowable Beam Flange Thickness parameter located above the user-defined value.

Assembly – Specific Comments

Hanger-Clevis-Anvil-260_290_66_Turnbuckle

- Refer to images below describing how to adjust the turnbuckle location.

Dimensions	
+ – Turnbuckle Vertical Adjustment	0' 0"
✗ Rod Extension Length Warning	
Maximum Rod Extension	0' 1 1/32"
Rod Extension Length	0' 0"
Pipe Center Elevation	6' 0"
Structure Height	10' 0"
Pipe Center to Beam	4' 0"
Size	

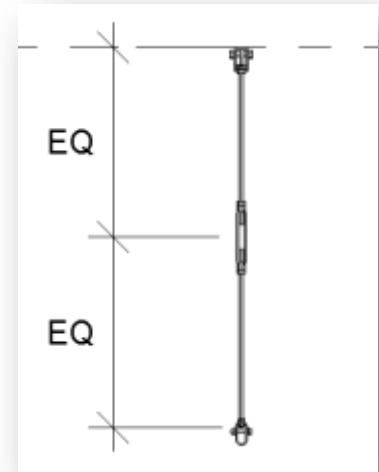

Example 28: The Turnbuckle's default location is between the Structure Height and the Rod Take Out Length of the Clevis Hanger.

Dimensions	
+ – Turnbuckle Vertical Adjustment	-0' 6" 
✗ Rod Extension Length Warning	
Maximum Rod Extension	0' 1 1/32"
Rod Extension Length	0' 0"
Pipe Center Elevation	6' 0"
Structure Height	10' 0"
Pipe Center to Beam	4' 0"
Size	



Example 29: The Turnbuckle's location can be adjusted within the Dimensions Parameter Group. The Turnbuckle vertical adjustment value can be either negative, positive, or 0.

Dimensions	
+ - Turnbuckle Vertical Adjustment	0' 6" 
✕ Rod Extension Length Warning	
Maximum Rod Extension	0' 1 1/32"
Rod Extension Length	0' 0"
Pipe Center Elevation	6' 0"
Structure Height	10' 0"
Pipe Center to Beam	4' 0"
Size	

Example 30: Increasing the turnbuckle's elevation.



Pipe_Roll_Stand-Anvil-177_Support

- Refer to images below describing how to adjust various parameters for this assembly.

Construction	
Beam Flange Thickness	0' 1 25/256"
Machine Threaded Rod Selector	1
1 Fig. 140 - Carbon Steel	<input checked="" type="checkbox"/>
2 Fig. 146 - Carbon Steel	<input type="checkbox"/>
3 Fig. 146 - Carbon Steel - Zinc Plated	<input type="checkbox"/>
4 Fig. 146 - Stainless Steel	<input type="checkbox"/>
Hanger Rod Diameter	0' 0 3/8"
Machine Threaded Rod Figure Number	140

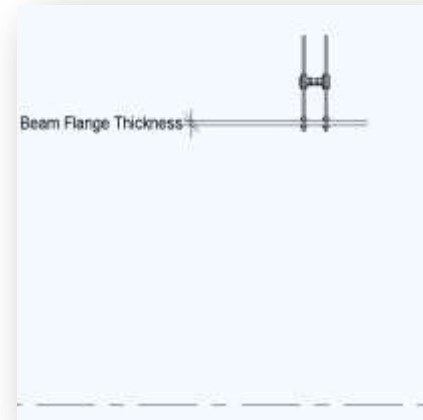

Example 31: Example of Beam Flange Thickness dimension, and where to edit this value in Revit.

Dimensions	
✘ Pipe Elevation Warning	
+ Maximum Allowable Pipe Elevation	46 11/128"
- Minimum Allowable Pipe Elevation	38 49/128"
Actual Pipe Center Elevation	3' 6"
Pipe Center Elevation	3' 6"
Structure Height	3' 0"
Rod Extension Length	0' 1 43/128"
Roller Elevation Height	3' 4 115/128"

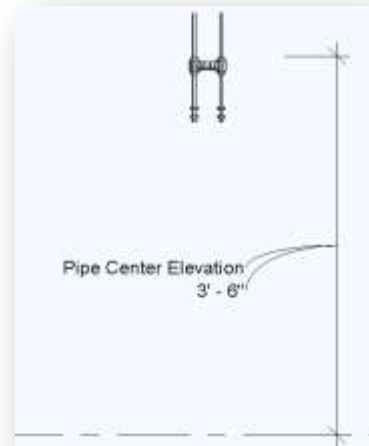

Example 32: Example of Pipe Center Elevation in Revit. Note that value must be within the specified range.

Dimensions	
✘ Pipe Elevation Warning	INVALID PIPE CENTER ELEVATION
+ Maximum Allowable Pipe Elevation	130 11/128"
- Minimum Allowable Pipe Elevation	122 49/128"
Actual Pipe Center Elevation	10' 30 11/128"
Pipe Center Elevation	20' 0"
Structure Height	10' 0"
Rod Extension Length	0' 1 43/128"
Roller Elevation Height	10' 8 63/64"
Size	

Example 33: Warning message for invalid pipe center elevation.

Dimensions:	
X Pipe Elevation Warning	
+ Maximum Allowable Pipe Elevation	48 11/128"
- Minimum Allowable Pipe Elevation	38 49/128"
Actual Pipe Center Elevation	3' 6"
Pipe Center Elevation	3' 6"
Structure Height	3' 0"
Rod Extension Length	0' 1 41/128"
Roller Elevation Height	3' 4 115/128"
Size	

Example 34: Example of structure Height parameter in Revit. It is measured from the bottom of the Revit Level to the upper threaded nut's bottom surface.

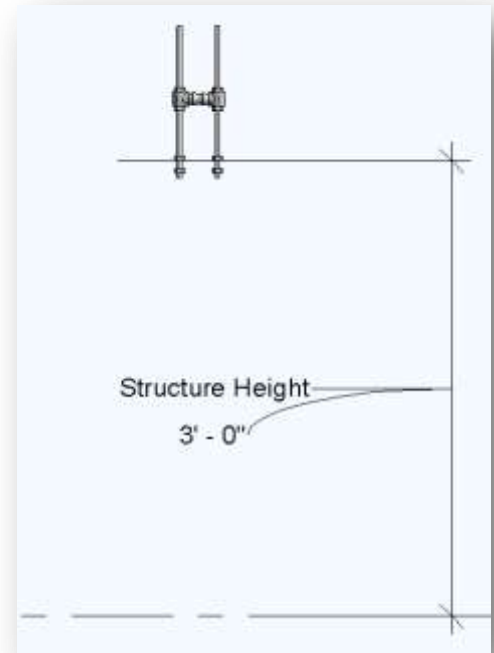

Pipe_Roll_Stand-Anvil-271_160_Support

- This is the only assembly where the user cannot define the *Pipe Center Elevation*. Instead, the user must define the *Structure Height*, as well as a suitable roller size based on the nominal pipe size.
- Refer to the images below describing how to adjust the mentioned parameters for this assembly.

Dimensions:	
Pipe Center Elevation	2' 3 1/2"
Structure Height	2' 0"
Size	

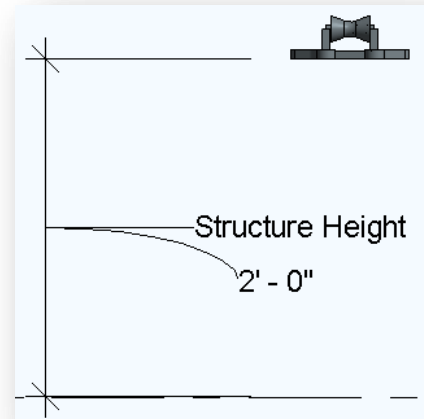

Example 35: Structure Height parameter in Revit. It is measured from the bottom of the level to the upper threaded nut's bottom surface.

Plumbing	
✖ Pipe Roll Size Warning	
+ Maximum Allowable Pipe Roll Size	3 1/2"
- Minimum Allowable Pipe Roll Size	2"
▲ Pipe Roll Stand Size	2"
Actual Pipe Roll Stand Size	
Nominal Pipe Size	2"
Nominal Pipe Radius	1"

Plumbing	
✖ Pipe Roll Size Warning	PIPE ROLL STAND SIZE UNAVAILABLE
+ Maximum Allowable Pipe Roll Size	3 1/2"
- Minimum Allowable Pipe Roll Size	2"
▲ Pipe Roll Stand Size	4"
Actual Pipe Roll Stand Size	
Nominal Pipe Size	2"
Nominal Pipe Radius	1"

Example 36: Pipe Roll Size Selection in Revit. Each pairing of insulation size and pipe size will influence the range of rollers available.

Example 37: Warning message for invalid Pipe Roll Stand selection.



Additional Resources

Link to Anvil's Website

<https://www.anvilintl.com/>

Link to Anvil's Hanger Content

<https://www.anvilintl.com/cds/?page=search&cid=pipe-hangers>

Link to Anvil's Smart Hanger Revit Families

<https://bim-catalog.anvilintl.com/>

Link to Anvil's BIM Portal

<https://www.anvilintl.com/bim-portal>

Link to ENGworks Website

<https://ENGworks.com/>

ANVIL INTERNATIONAL

2 Holland Way, Exeter, NH 03833
603-418-2800 P 603-418-2833 F
www.anvilintl.com

SMITH-COOPER INTERNATIONAL

2867 Vail Avenue, Commerce, CA 90040
800-768-0076 P 323-890-4456 F
www.smithcooper.com

POWER AND PROCESS OFFICE

160 Frenchtown Road, North Kingstown, RI 02852
401-886-3000 P 401-886-3010 F
401-533-6896 EMERGENCY
www.anvileps.com