

## **APPENDIX C**

### **Environmental Mitigation Plan**

*This page left intentionally blank.*

## **APPENDIX C1**

### **Minnesota and North Dakota Environmental Mitigation Plan**

*This page left intentionally blank.*



**Enbridge Energy, Limited Partnership  
Enbridge Pipelines (Southern Lights) L.L.C.**

**Alberta Clipper and  
Southern Lights Diluent  
Pipeline Projects**

**Minnesota and North Dakota  
Environmental Mitigation Plan**

**March 20, 2009**

**ENBRIDGE ENERGY, LIMITED PARTNERSHIP  
 ENBRIDGE PIPELINES (SOUTHERN LIGHTS) L.L.C.  
ALBERTA CLIPPER AND SOUTHERN LIGHTS DILUENT PROJECTS**

**MINNESOTA AND NORTH DAKOTA ENVIRONMENTAL MITIGATION PLAN**

**TABLE OF CONTENTS**

INTRODUCTION .....	1
1.0 GENERAL MITIGATION MEASURES .....	3
1.1 CONSTRUCTION EQUIPMENT EMISSIONS .....	3
1.2 TEMPORARY EROSION AND SEDIMENT CONTROLS .....	3
1.3 RIGHT-OF-WAY ACCESS .....	3
1.4 ROAD REPAIR.....	4
1.5 RIGHT-OF-WAY REQUIREMENTS.....	4
1.6 LINE LIST AND PERMITS .....	5
1.7 UPLAND CLEARING .....	5
1.6.1 Disposal of Non-Merchantable Timber.....	5
1.6.2 Disposal of Merchantable Timber.....	6
1.6.3 Upland Grading and Stump Removal.....	6
1.6.4 Fencing.....	6
1.6.5 Trees and Shelterbelts .....	6
1.6.6 Irrigation Systems.....	6
1.6.7 Drain Tile Inlets .....	6
1.6.8 Upland Topsoil Segregation .....	7
1.6.9 Temporary Erosion and Sediment Controls .....	8
1.6.10 Temporary Slope Breakers.....	9
1.6.11 Noise and Dust Control .....	10
1.8 PIPE DELIVERY, BENDING & WELDING .....	10
1.9 UPLAND TRENCHING .....	10
1.9.1 Timing.....	10
1.9.2 Pipeline Depth .....	10
1.10 PIPE INSTALLATION.....	11
1.11 TRENCH BREAKERS .....	11
1.12 DRAIN TILE REPAIR .....	11
1.13 UPLAND BACKFILLING .....	11
1.14 WET WEATHER SHUTDOWN .....	12
1.15 CONTROLLING SPREAD OF UNDESIRABLE SPECIES.....	12
1.16 CLEANUP AND ROUGH/FINAL GRADING.....	12
1.17 TIMING.....	13

1.18	PERMANENT EROSION AND SEDIMENT CONTROLS .....	13
1.19	SOIL COMPACTION TREATMENT .....	13
1.20	STONE REMOVAL .....	14
1.21	OFF-ROAD VEHICLE CONTROL MEASURES.....	14
1.22	REPAIR OF DAMAGED CONSERVATION PRACTICES.....	14
1.23	LAND LEVELING FOLLOWING CONSTRUCTION.....	14
2.0	STREAM AND RIVER CROSSING GENERAL REQUIREMENTS .....	15
2.1	TIME WINDOW FOR CONSTRUCTION.....	15
2.2	PRE-CONSTRUCTION CONSIDERATIONS.....	15
2.2.1	Hazardous Materials.....	15
2.2.2	Refueling/Equipment Care.....	15
2.2.3	Alignment of Crossing.....	16
2.3	CLEARING AND GRADING.....	16
2.4	EXTRA WORKSPACE .....	16
2.5	BRIDGES .....	17
2.5.1	Types of Bridges.....	17
2.5.2	Bridge Design and Maintenance.....	17
2.6	STREAM AND RIVER CROSSING CONSTRUCTION METHODS.....	18
2.6.1	Wet Trench Method .....	18
2.6.2	Dam and Pump Method.....	19
2.6.3	Flume Method.....	20
2.6.4	Directional Drill and/or Guided Bore Method .....	21
2.7	DRAINAGE DITCHES AND INTERMITTENT STREAMS.....	22
2.8	PERMANENT RESTORATION.....	22
3.0	WETLAND CROSSING GENERAL REQUIREMENTS .....	25
3.1	WETLAND ACCESS .....	25
3.2	SPILL PREVENTION .....	25
3.2.1	Storage of Fuels and Other Materials.....	25
3.2.2	Refueling, Fuel Handling, and Equipment Maintenance.....	25
3.3	CLEARING .....	26
3.4	GRADING IN A WETLAND .....	26
3.5	CONSTRUCTION MATTING .....	27
3.6	TRENCHING .....	27
3.6.1	Topsoil Segregation.....	27
3.6.2	Trench Breakers .....	27
3.7	PIPELINE INSTALLATION.....	27
3.7.1	Push/Pull Method.....	28
3.7.2	Non-Winter Construction within Extremely Saturated Wetlands..	28
3.7.3	Temporary Erosion and Sediment Controls.....	28

3.7.4	Concrete Coating.....	28
3.8	BACKFILLING .....	29
3.9	ROUGH GRADING, CLEANUP, AND TEMPORARY RESTORATION ..	29
3.9.1	Timing.....	29
3.9.2	Temporary Stabilization.....	29
4.0	HIGHWAY, ROAD and RAIL CROSSINGS .....	30
4.1	ADDITIONAL WORKSPACE.....	30
4.2	MAINTENANCE .....	30
4.3	TEMPORARY EROSION AND SEDIMENT CONTROLS.....	30
5.0	CONSTRUCTION DEWATERING .....	31
5.1	TRENCH DEWATERING .....	31
5.1.1	Regulatory Notification and Reporting.....	32
5.1.2	Water Sampling .....	32
5.2	HYDROSTATIC TEST DISCHARGES.....	32
5.2.1	Refueling .....	32
5.2.2	Permit Requirements.....	33
5.2.3	Siting of Test Manifolds .....	33
5.2.4	Water Sampling .....	33
5.2.5	Best Management Practices.....	33
5.2.6	Flow Measurement.....	34
6.0	WATER APPROPRIATION.....	35
6.1	GENERAL .....	35
6.2	WATER SOURCES.....	35
6.3	FLOW MEASUREMENT .....	35
6.4	WATER SAMPLING .....	35
6.5	REGULATORY NOTIFICATION AND REPORTING .....	35
7.0	REVEGETATION .....	36
8.0	WINTER CONSTRUCTION .....	36



## FIGURES<sup>1</sup>

Figure 1A	Typical Construction Layout - (Neché, ND to Clearbrook, MN)
Figure 1B	Typical Construction Layout - (Clearbrook, MN to Superior, WI)
Figure 2A	Typical Topsoil Segregation – Modified Ditch Plus Spoil Side – (Neché, ND to Clearbrook, MN)
Figure 2B	Typical Topsoil Segregation – Modified Ditch Plus Spoil Side - (Clearbrook, MN to Superior, WI)
Figure 3A	Typical Topsoil Segregation – Full Right-of-Way - (Neché, ND to Clearbrook, MN)
Figure 3B	Typical Topsoil Segregation – Full Right-of-Way - (Clearbrook, MN to Superior, WI)
Figure 4A	Typical Topsoil Segregation – Trench Line Only - (Neché, ND to Clearbrook, MN)
Figure 4B	Typical Topsoil Segregation – Trench Line Only - (Clearbrook, MN to Superior, WI)
Figure 5	Typical Temporary or Permanent Berms – Perspective View
Figure 6	Typical Temporary or Permanent Berms – Elevation View
Figure 7	Typical Silt Fence Installation
Figure 8	Typical Straw Bale Installation
Figure 9	Typical Trench Breakers – Perspective View
Figure 10	Typical Trench Breakers – Plan and Profile Views
Figure 11	Permanent Slope Breakers – Perspective View
Figure 12	Erosion Control Blanket – Steep Slopes (≥30%)
Figure 13A	Typical Waterbody Crossing – Wet Trench Method - (Neché, ND to Clearbrook, MN)
Figure 13B	Typical Waterbody Crossing – Wet Trench Method - (Clearbrook, MN to Superior, WI)
Figure 14A	Typical Waterbody Crossing – Dam and Pump Method- (Neché, ND to Clearbrook, MN)
Figure 14B	Typical Waterbody Crossing – Dam and Pump Method- (Clearbrook, MN to Superior, WI)
Figure 15A	Typical Waterbody Crossing – Flume Method- (Neché, ND to Clearbrook, MN)
Figure 15B	Typical Waterbody Crossing – Flume Method- (Clearbrook, MN to Superior, WI)
Figure 16	Typical Waterbody Crossing – Directional Drill Method
Figure 17	Typical Span Type Bridge With and Without Support (Timber Mat Bridge)
Figure 18	Typical Rock and Flume Bridge
Figure 19	Typical Dewatering Measures
Figure 20	Typical Straw Bale Dewatering Structure
Figure 21	Typical Final Stream Bank Stabilization – Rip Rap & Erosion Control
Figure 22A	Alberta Clipper Stream Crossing Replanting (Neché, ND to Clearbrook, MN)
Figure 22B	Alberta Clipper Stream Crossing Replanting (Clearbrook, MN to Superior, WI)
Figure 23A	Typical Wetland Crossing- (Neché, ND to Clearbrook, MN)
Figure 23B	Typical Wetland Crossing- (Clearbrook, MN to Superior, WI)
Figure 24	Summer Saturated Wetland Construction ROW Southern Lights Construction
Figure 25	Summer Saturated Wetland Construction ROW Alberta Clipper Construction
Figure 26A	Typical Improved Road Crossing-Directional Bore -(Neché, ND to Clearbrook, MN)
Figure 26B	Typical Improved Road Crossing-Directional Bore -(Clearbrook, MN to Superior, WI)
Figure 27	Winter Wetland Construction – Frost/Ice Road Construction, ROW Configuration
Figure 28	Winter Saturated Wetland Construction – So. Lights Diluent ROW Configuration
Figure 29	Winter Non-Saturated Wetland Construction – So. Lights Diluent ROW Configuration
Figure 30	Winter Saturated Wetland Construction – Alberta Clipper ROW Configuration
Figure 31	Winter Non-Saturated Wetland Construction – Alberta Clipper ROW Configuration
Figure 32A	Right-of-Way Configuration (Neché, ND to Clearbrook, MN)
Figure 32B	Right-of-Way Configuration (Clearbrook, MN to Superior, WI)

---

<sup>1</sup> Site-specific plans supersede any design presented in the typical details.

## INTRODUCTION

This Environmental Mitigation Plan (EMP) outlines construction-related environmental policies, procedures, and mitigation measures developed by Enbridge Energy, Limited Partnership and Enbridge Pipelines (Southern Lights) L.L.C. (Enbridge or Company) for the construction of the Alberta Clipper and Southern Lights Diluent Pipeline Projects. This EMP was developed based on Enbridge's experience implementing best management practices during construction. It is intended to meet or exceed applicable federal, state, tribal, and local environmental protection and erosion control specifications and practices. The EMP is designed to address typical circumstances that may be encountered along the Enbridge Alberta Clipper and Southern Lights Diluent Projects. Project-specific permit conditions and/or landowner agreements may supersede general practices described in this document. Project-specific procedures for the Alberta Clipper and Southern Lights Diluent Projects have been incorporated into the EMP. The measures described in the EMP are consistent with relevant portions of the State of Minnesota *Stormwater Manual*, the Minnesota *Protecting Water Quality in Urban Areas Manual*, and North Dakota's *Guide to Temporary Erosion-Control Measures for Contractors, Designers, and Inspectors*.

This document includes the following sections:

- Section 1.0 of the EMP describes general mitigation measures, including soil erosion and sedimentation control procedures, to be implemented during upland construction and upland restoration;
- Section 2.0 discusses stream and river construction, crossing, and restoration;
- Section 3.0 describes practices for wetland construction, crossings, and restoration;
- Section 4.0 discusses highway, road, and rail crossings;
- Section 5.0 discusses construction dewatering;
- Section 6.0 outlines water appropriation practices;
- Section 7.0 addresses revegetation measures;
- Section 8.0 addresses winter construction issues;

Alternative construction procedures implemented in lieu of this EMP must provide an equal or greater level of protection to the environment, and must be approved in writing by Enbridge. Modifications for the construction of dual pipelines are highlighted below in the appropriate sections.

Unless otherwise specified, the construction Contractor (Contractor) will be responsible for implementing the requirements of this EMP. Enbridge will make the requirements of the EMP and applicable environmental permits known to the Contractor. If the Contractor has questions concerning these environmental requirements, the Contractor will contact an Enbridge representative.

Enbridge will provide appropriate construction oversight to confirm Company and Contractor compliance with the measures of this EMP and requirements of applicable federal, state, tribal, and local permits. Enbridge's Environmental Inspectors (EIs) will assist the Contractor in interpreting and implementing the requirements of the EMP, and verify compliance

with these procedures for the company. Enbridge employs experienced EIs to manage unforeseen situations that are not directly addressed by the project documents. Enbridge relies on the experience and judgment of the EIs through coordination and consultations with project management staff to address those unforeseen situations should they occur in the field. The EI will be expected to use judgment in the field to interpret environmental conditions and requirements, but will not be authorized to make major modifications or changes without the prior written approval of Enbridge. The EI will have the authority to stop activities and order corrective mitigation for actions that are not in compliance with the measures in this EMP, Landowner agreements, or environmental permit requirements. The EI will maintain appropriate records to document compliance with these and other applicable environmental permit conditions.

Enbridge will also hire Independent Environmental Monitors (Monitors or IEMs), approved by Enbridge and the applicable state agencies, to document compliance with permits and plans. Monitors will work collaboratively with Enbridge's environmental and agricultural inspection team to achieve compliance, as well as work in an auditing role to assess the success of Enbridge's compliance program. Environmental Monitors will be responsible for monitoring Enbridge's compliance with permits issued by the applicable state and federal agencies. Monitors will communicate through daily reports submitted to the applicable state agencies and Enbridge, as well as through daily communication with Enbridge's Environmental Inspection Team. Monitors will communicate directly with their respective agency contacts and with Enbridge's EIs, but will not communicate directly with the Contractor or sub-Contractor unless an Enbridge EI is present. Monitors will not have the authority to direct construction team activities, and will work through Enbridge's Environmental Inspection Team, if compliance issues are identified.

Enbridge will also work with independent Tribal Monitors who will work collaboratively with Enbridge's Environmental Inspection Team, in an advisory role, to assist in achieving compliance with the Programmatic Agreement (PA) developed for this project as well as the applicable Unanticipated Discoveries Plan to protect known cultural resource sites as well as sites that may be discovered during construction. Tribal Monitors will communicate directly with Enbridge's EIs, but will not communicate directly with the Contractor or sub-Contractor unless an Enbridge EI is present. Similar to IEMs, Tribal Monitors will not have the authority to direct construction crews or equipment and will work through Enbridge's Environmental Inspection Team if concerns are identified. Additional roles and responsibilities of the Tribal Monitor are described in Enbridge's Construction Environmental Control Plan.

Enbridge has prepared this Minnesota and North Dakota Environmental Mitigation Plan (MN/ND EMP or EMP) for use in the construction and restoration of the Albert Clipper and Southern Lights Diluent Pipeline Projects (hereby referred to as the Project)

## **1.0 GENERAL MITIGATION MEASURES**

### **1.1 CONSTRUCTION EQUIPMENT EMISSIONS**

In an effort to reduce emissions of criteria and hazardous air pollutants associated with the operation of construction equipment, Enbridge will require that construction equipment working on the project be maintained in accordance with the manufactures specifications. In addition, Enbridge will encourage its contractors to:

- Ensure that diesel-powered equipment is properly maintained and shut off when not in use;
- Prohibit engine tampering to increase horsepower;
- Where practicable, operate equipment as far as possible from residential areas and sensitive receptors (schools, daycare centers, and hospitals);
- Use ultra low sulfur diesel fuel for their equipment if it is available for purchase within a reasonable distance to the construction spreads;
- Minimize to the extent practicable, construction-related trips of workers and equipment; and,
- Where practicable, use 1996 or newer model year equipment and vehicles.

Furthermore, Enbridge will require that Enbridge company-owned or leased vehicles working on the project be properly maintained and shut off when not in use. For diesel-powered Enbridge-owned or leased equipment, Enbridge will:

- Prohibit engine tampering to increase horsepower;
- Use ultra low sulfur diesel fuel for vehicles if it is available for purchase within a reasonable distance to the construction spreads;
- Minimize to the extent practicable, construction-related trips; and,
- Where practicable, use 1996 or newer model year vehicles.

### **1.2 TEMPORARY EROSION AND SEDIMENT CONTROLS**

Temporary erosion and sediment controls (ECDs) include, but are not limited to, slope breakers, sediment barriers, stormwater diversions, trench breakers, mulch, and revegetation. The goal of ECDs is to minimize erosion onsite, and prevent construction-related sediment from migrating offsite into sensitive resource areas such as streams, wetlands, lakes, or drainage ditches (dry or flowing). The Contractor will, at all times, maintain erosion and sediment control structures as required in the project construction documents and as required by all applicable permits. Non-functional erosion and sediment control features must be repaired, replaced, or supplemented with functional materials within 24 hours after discovery, or as soon as field conditions allow the features to be repaired.

ECDs will be installed after initial clearing but before disturbance of the soil, and will be replaced by permanent erosion controls as restoration is completed. Additional information on ECDs is provided in the upland, waterbody, and wetland sections.

### **1.3 RIGHT-OF-WAY ACCESS**

Access to the right-of-way (ROW) will be from public roadways and Enbridge-approved private access roads only. Enbridge is responsible for creating signs or other methods to identify approved access roads in the field and to ensure that access is confined to only the approved roads. Vehicle tracking of soil from the construction site will be minimized by installation of Best Management Practices (BMPs) such as stone pads, timber mats, or equivalent. Soil tracked onto public roads will be removed.

## 1.4 ROAD REPAIR

The Contractor will repair private roads, lanes, and public roads damaged when moving equipment or obtaining access to the ROW.

## 1.5 RIGHT-OF-WAY REQUIREMENTS

All construction equipment and vehicles will be confined to the approved ROW and extra workspace. Although ROW requirements may vary between projects, construction activities for the Alberta Clipper and Southern Lights Diluent Projects will generally use a ROW as shown in Figures 1A and 1B. These drawings illustrate the Typical Construction Layout and ROW Configurations for the projects. The construction ROW configurations may be modified to avoid and/or minimize disturbance to sensitive resource areas such as wetlands and waterways.

Prior to commencement of clearing operations, the outer limits of the construction ROW and extra workspace areas will be marked with distinctive stakes and flagging by Enbridge. Construction activities will be restricted to the approved designated areas. Other areas (pipe storage and contractor yards, borrow and disposal areas, access roads, etc.) will be posted for use by the Contractor during construction activities.

The construction ROW (construction workspace) for the Alberta Clipper and Southern Lights Diluent Projects will include a portion of Enbridge's existing corridor, new permanent corridor, permitted temporary workspace, and site-specific extra workspaces as defined below and shown in Figures 1A through 4B. Typically the construction ROW will be 140-foot-wide. The construction ROW width will be reduced to 125-foot-wide in selected locations (e.g., wetlands, waterbodies, and forested windbreaks), in accordance with applicable permit conditions, as indicated on the project construction alignment sheets and in the field by the use of staking.

### (a) ROW (Permanent)

Enbridge's existing permanent ROW is generally 125 feet wide. Enbridge will be adding up to an additional 75 feet of permanent ROW, depending on the location of the new pipelines in relation to the existing pipelines (refer to Figures 32A and 32B). The ROW is maintained to facilitate access and aerial inspection of the pipeline system.

### (b) Temporary Workspace

In addition to the ROW/permanent corridor, construction will require Temporary Workspaces (TWS). The TWS will be located adjacent to and contiguous with the proposed ROW/permanent corridor and will be identified on the construction alignment sheets and by distinctive staking of construction limits prior to clearing.

### (c) Extra Workspace

Site-specific extra workspace (EWS) locations, (construction work areas beyond the permanent corridor and TWS previously described), will be required at select locations such as steep slopes, road, waterbody, railroad, some wetland crossings, and where it is necessary to cross under the existing pipelines or foreign utilities. EWS will typically be located in uplands adjacent to the construction ROW and set 50-feet back from sensitive resource boundaries where site-specific field conditions allow. However, to complete work safely, Enbridge may need to locate EWS within a wetland or within the 50-foot

setback from a wetland or waterbody based on site-specific conditions. EWS adjacent to waterbodies and/or wetlands is addressed further in sections 2.4 and 3.3, respectively.

Enbridge will acquire EWS from the landowner where necessary; use of unauthorized workspace is prohibited without Enbridge's approval. In all cases, the size of EWS will be kept to the minimum necessary to safely conduct work. Enbridge has conducted a preconstruction review of the entire project area to determine specific EWS locations. All approved EWS locations are depicted on the construction alignment sheets.

## **1.6 LINE LIST AND PERMITS**

Enbridge will provide the Contractor with a Construction Line List (CLL) that describes special requirements (e.g., timber salvage, topsoil segregation, restoration measures, fencing requirements, etc.) as agreed upon with Landowners. The Contractor must comply with these special requirements and/or permit conditions.

The CLL reflects requirements and comments provided by Landowners; however it is not a comprehensive list of construction requirements. The CLL must be considered in conjunction with other project documents and permits. Any third party agreements between the Contractor and the landowner must be pre-approved by Enbridge and in writing.

Unless otherwise noted within this EMP, Enbridge will obtain the necessary permits for the installation of the pipeline. Permit requirements may be more stringent than the requirements of this EMP. In all cases, the more restrictive requirements will apply.

## **1.7 UPLAND CLEARING**

The initial stage of construction involves the clearing of brush, trees, and tall herbaceous vegetation from the ROW. Clearing may be accomplished with chain saws, mowers, and hydraulic tree-cutting equipment.

### **1.7.1 Disposal of Non-Merchantable Timber**

Unless otherwise directed by Enbridge, non-merchantable timber and slash will be disposed of by mowing, chipping, grinding, and/or hauling off site to an approved disposal facility or used in stabilizing erodible slopes or construction entrances. In non-agricultural, non-wetland areas, chips may be uniformly broadcast (less than 1-inch thickness) across the ROW where they would ultimately be incorporated into the topsoil layer during grading activities, with landowner approval. Burning of non-merchantable wood may be allowed only where the Contractor has acquired all applicable permits and approvals (e.g. agency, tribal, and landowner) and in accordance with all tribal, state, and local regulations. The Contractor must provide Enbridge with copies of these permits and/or approvals prior to initiating burning.

Burning will not be allowed within 100 feet of a wetland or waterbody without site-specific approval from Enbridge. Burning will not be allowed in wetlands. No chips, mulch, or mechanically cut woody debris will be stockpiled in a wetland and no upland woody debris will be disposed of in a wetland (see section 3.3 for further information on clearing in a wetland). Non-merchantable timber may not be disposed of by placing it off the ROW. No woody debris disposal will be allowed in agricultural areas or wetlands.

### **1.7.2 Disposal of Merchantable Timber**

All merchantable timber will be the property of the Company and the Contractor will be responsible for merchandising timber. If a commercial buyer cannot be found, the timber may be considered non-merchantable and disposed of as referenced in Disposal of Non-Merchantable Timber (section 1.7.1).

### **1.7.3 Upland Grading and Stump Removal**

Grading generally follows clearing and involves leveling and smoothing the construction ROW, including TWS, and EWS areas as necessary, to create a safe, even working surface for equipment and vehicles. To facilitate proper cleanup and restoration in upland areas, tree stumps outside the ditchline will be ground no less than four-inches below normal ground surface or completely removed and hauled off to an approved disposal facility. Stumps in the ditch line will be completely removed, ground, and/or hauled off to an approved disposal facility. Topsoil and subsoil disturbed during grading operations will not be mixed with foreign material (e.g., stumps and brush).

### **1.7.4 Fencing**

Before or during clearing of the ROW, existing fences and livestock barriers will be cut as necessary to access the ROW. Existing fencing will be H-Braced and secured prior to cutting to prevent the slacking of wires. Temporary gates and/or fencing will be installed where necessary to maintain existing access restrictions, contain livestock and protect sensitive areas. These temporary measures will remain in place until construction is completed and permanent repairs or new fencing can be installed.

### **1.7.5 Trees and Shelterbelts**

Care will be taken to minimize tree removal. To the extent practicable, and in accordance with applicable permits, wind breaks and shelterbelts will be crossed by minimizing the width of the ROW. When clearing, trees will be felled onto the ROW to minimize damage to off-ROW vegetation. Shelterbelts within the TWS and EWS must be replanted in accordance with applicable project permits and/or landowner agreements.

### **1.7.6 Irrigation Systems**

If pipeline construction activities interfere with the operation of spray irrigation systems, Enbridge will establish with the landowner or Tenant, an acceptable amount of time the irrigation system may be out of service. If feasible, temporary measures will be implemented to allow an irrigation system to continue to operate across the ROW during pipeline construction. Any damage to irrigation systems caused by construction-related activities will be repaired following backfilling.

### **1.7.7 Drain Tile Inlets**

Enbridge will attempt to locate existing drain tile inlets that are located near the construction work area prior to construction. Drain tile inlets will be marked using flags. Located drain tile inlets with the potential to receive stormwater from the construction project will be protected by using the appropriate ECDs until sources with the potential to discharge has been stabilized. The determination of the specific ECD will be made based on the location of an inlet with respect to the project area, drainage area from the construction work area to the inlet, topography, vegetation, soils, and accessibility to the inlet. Where drain tile inlets are located off of Enbridge's ROW, Enbridge may not have authorization to install ECDs at the inlet site. In

these cases, sediment control measures (typically silt fence) will be installed along the edge of the construction work area that drains to the inlet structure to minimize sedimentation.

### **1.7.8 Upland Topsoil Segregation**

Topsoil generally has physical and chemical properties that are conducive to good plant growth. To prevent the mixing of topsoil with less productive subsoil during construction, topsoil will be segregated in selected areas where soil productivity is an important consideration. A minimum one foot of separation must be maintained between the topsoil and subsoil piles to prevent mixing. Where the one foot separation cannot be maintained, a physical barrier, such as a thick layer of straw mulch, may be used between the spoil and topsoil piles to prevent mixing. Use of the physical barrier must be reviewed and approved by Enbridge on a site-specific basis. Upland areas where topsoil will be stripped include cropland, hay fields, pasture, residential areas, and other areas as requested by the landowner. Topsoil will not be used to construct trench breakers (see section 1.11) or to pad the pipe. Gaps must be left and ECDs installed where stockpiled topsoil and spoil piles intersect with water conveyances (i.e., ditches, swales, and waterways) to maintain natural drainage.

#### **Topsoil Segregation Methods**

The following topsoil segregation methods may be employed during construction:

- Modified Ditch-Plus-Spoil Side (see Figures 2A and 2B)
- Full ROW (see Figures 3A and 3B)
- Trench-Line-Only (see Figures 4A and 4B)

A Modified Ditch-Plus-Spoil topsoil segregation technique will typically be used in active cropland, which will consist of stripping topsoil from the spoil storage area, ditchline, and the primary travel lane. Based on Enbridge's experience during construction of its LSr Pipeline, this method will provide a greater level of protection to the topsoil resource while still reducing the amount of topsoil material to be moved relative to the Full ROW technique. Alternative topsoil segregation methods may be used on a site-specific basis or as requested by the landowner. The Trench-Line-Only topsoil segregation method may be used where Enbridge determines that the width of the construction ROW is insufficient for other methods to be used. Enbridge may also use the Trench-Line-Only topsoil segregation method in areas where there is a thick sod layer such as in hay fields, pastures, golf courses, and residential areas, unless otherwise requested by the landowner.

Topsoil is not typically segregated in forested areas, standing water wetlands, and nonagricultural open areas. However, in areas of steep side slopes adjacent to wetlands and waterbodies, including forested areas, where subsoil will be excavated (e.g., two-toned, side-cut, etc.) to create a level workspace, topsoil will be segregated to the extent practicable and in the direction of Enbridge.

#### **Depth of Upland Topsoil Stripping**

With the exception of the Red River Valley, topsoil will be stripped to a maximum depth of 12 inches in active crop lands, unless otherwise requested by the landowner. Within the Red River Valley, Enbridge will strip up to 18 inches of topsoil, or to actual depth if less than 18



inches. For this project, the Red River Valley is defined as the area beginning at the Red River crossing and extending east to the Tamarac River crossing in Minnesota. Additional space may be needed for spoil storage if more than 12 inches of topsoil are segregated. If less than 12 inches of topsoil are present, the Contractor shall attempt to segregate to the depth that is present.

### **1.7.9 Temporary Erosion and Sediment Controls**

ECDs are intended to slow the velocity of water off-site to minimize erosion, stop the movement of sediments off the construction ROW, and prevent the deposition of sediments into sensitive resources that may be on or adjacent to the ROW. ECDs typically used are silt fence and/or trenched-in and staked straw bales and other barriers such as compacted earth (e.g., drivable berms across travel ways), sand bags, or other appropriate materials. If temporary ECDs are removed during the day to allow equipment access, they must be reinstalled at the end of the day.

Temporary ECDs will be installed after clearing and prior to grubbing and grading activities at the base of sloped approaches to streams, wetlands, and roads. Temporary ECDs will also be installed at the edge of the ROW as needed, and/or in other areas determined by the EI to slow water leaving the site and prevent siltation of waterbodies and wetlands downslope or outside of the construction ROW (e.g., swales and side slopes). Temporary ECDs will be placed across the entire construction ROW at the base of slopes greater than 5 percent where the base of the slope is less than 50 feet from tile line inlets, drainage ways, wetlands, and/or waterbodies until the area is revegetated and there is no potential scouring or sediment transport to surface waters.

If silt fence is in use, when the depth of sediment reaches about one-third of the height, the sediment will be removed. Non-functional ECDs will be repaired, replaced, or supplemented with functional structures within 24 hours after discovery, or as soon as field conditions allow the features to be repaired.

Temporary ECDs installed across the travel lane may be removed during active daytime construction; however, ECDs must be reinstalled after equipment passage, or activities in the area are completed for the day. These ECDs must also be repaired and/or replaced prior to forecasted inclement weather. The Contractor is responsible for monitoring weather conditions and adjusting resources as needed to address pending and/or existing weather conditions.

### **Temporary Stabilization**

Installation of temporary seeding, mulch, and erosion control mats may be required by Enbridge in certain locations if there are construction delays within a spread of at least 14 days. The Contractor may be required by Enbridge to install temporary stabilization materials sooner based on site conditions, or as required in Enbridge's Individual NPDES/SDS permit in Minnesota. Temporary stabilization measures as outlined in Enbridge's Revegetation and Restoration Monitoring Plan will be implemented to minimize erosion and for sediment control..

Enbridge will install the appropriate class of erosion control blanket on slopes greater than 5 percent that would be exposed over the winter and drain to surface waters. Enbridge will attempt to install erosion control blankets on the exposed slopes prior to snowfall; however, construction progress and/or seasonal weather variations may prevent installation prior to the first snowfall. Installation of erosion control blankets and additional BMPs, as applicable based

on site conditions, would continue after the first snowfall to protect slopes prior to spring melt and runoff.

## Mulch

Mulch will be applied as indicated in Enbridge's Revegetation and Restoration Monitoring Plan. If exposed soils have not been stabilized prior to freezing of the ground, and soil conditions are such that disking is still effective, crimp in straw mulch to help stabilize these areas, but on steeper slopes blanket is still preferable.

### 1.7.10 Temporary Slope Breakers

Temporary slope breakers will to be installed to minimize concentrated or sheet flow runoff in disturbed areas in accordance with the following maximum allowable spacing unless otherwise specified in permit conditions.

<u>Slope (%)</u>	<u>Approximate Spacing (ft)</u>
3-5	250
5-15	200
15-25	150
>25	<100

If the length of the slope is less than the distance of the required spacing, slope breakers are not required unless a sensitive resource area (e.g., wetland) is located immediately down slope, or as requested by the EI. Temporary slope breakers may be constructed using earthen subsoil material, silt fence, hay bales, or in non-agricultural land, rocked trenches may be used. On highly erodible slopes, slope breakers in the form of either earthen berms or rocked trenches will be used whenever possible.

Temporary slope breakers will be constructed according to the following specifications:

- earthen berms will be installed with a 2 to 4 percent outslope, with a minimum 4 foot base and a minimum height of 1.5 feet (see Figures 5 and 6);
- hay bales used as slope breakers will be trenched in and staked so as to not allow spacing between bales or allow flow underneath the bales;
- the outfall of temporary slope breakers will be directed off the construction ROW into a stable well-vegetated upland area or into an appropriate energy-dissipating sediment control device (e.g., silt fence, straw bales, rock aprons) to prevent the discharge of sediments (see Figure 5);
- proper slope breaker outfalls will be established where topsoil segregation and/or grading has created a barrier at the edge of the construction workspace;
- gaps will be created through spoil piles where necessary to allow proper out letting of temporary berms;
- temporary slope breakers will be inspected daily and repaired as necessary, but no more than 24 hours after discovery or as soon as access allows, to maintain operational integrity and prevent erosion in active construction areas.

### **1.7.11 Noise and Dust Control**

The Contractor will take all reasonable steps to control construction-related noise and dust near residential areas and other areas as directed by Enbridge. Control practices may include wetting the ROW and access roads, limiting working hours in residential areas, reestablishment of vegetation and/or additional measures as appropriate based on site-specific conditions.

### **1.8 PIPE DELIVERY, BENDING & WELDING**

Typically, individual joints of pipe will be strung along the construction ROW before excavating the pipeline trench. This operation involves specially designed equipment to deliver pipe from pipe storage yards to the ROW. Where practical, Enbridge will drive stringing trucks along an alignment which corresponds closely to the pipeline centerline to minimize the potential for soil compaction in actively cultivated areas.

After pipe stringing is complete, the pipe will be bent, as necessary, to conform to changes in ground contours and pipeline alignment. Individual pipe joints will be welded together and the welds will be radiographically inspected. The welds will then be coated to protect them from corrosion.

### **1.9 UPLAND TRENCHING**

Trenching in uplands consists of excavating the trench for the pipeline, and is typically accomplished with a backhoe excavator or a rotary wheel ditching machine. Excavated material will be sidecast (stockpiled) within the approved construction ROW separate from topsoil (see section 1.7.8), and stored such that the area subject to erosion is minimized. Enbridge will coordinate with Landowners to minimize disruption of access caused by the trench during construction. Where deemed appropriate by the Company, Enbridge will leave plugs of soil in the ditch or will construct temporary access bridges across the trench for the landowner to move livestock or equipment. Trenches will also be sloped where started and ended to allow ramps for wildlife to escape.

#### **1.9.1 Timing**

The length of time a trench is left open will be minimized to ensure that installation of the pipe and restoration of the ROW occurs in a timely fashion. Enbridge will limit the amount of excavated open trench to 2 days of anticipated welding production or approximately 14,000 feet per spread, per pipe. Site specific activities such as HDDs, guided bores, road bores, tie-in points, and valve work may be performed independent of a spread. Each spread will be fully equipped and staffed to operate independently of one another.

#### **1.9.2 Pipeline Depth**

At a minimum, the pipeline will be buried in accordance with U.S. Department of Transportation regulations (40 CFR Part 195), which stipulate a minimum of three (3) feet of top cover for normal excavations, and 18 to 30 inches of cover for rock excavations (depending on the location), to prevent damage to the pipeline from normal use of the land.

For the Alberta Clipper and Southern Lights Diluent Projects, the depth of cover will vary from 36 inches to 60 inches, depending on state law, permit requirements, landowner agreements, and site-specific conditions (e.g., depth of drain tile). If a state-level agency specifies a more stringent requirement for pipeline depth than the DOT and/or landowner requirements, the Company may request a waiver of that requirement. Increased pipeline depth

will result in greater amounts of ditch spoil and, consequently, may require additional temporary workspace for storage of the spoil.

### **1.10 PIPE INSTALLATION**

Once the trench has been inspected for proper depth, rocks, or other obstructions, the welded pipe is lowered into the trench. In rocky soils, the pipe may be wrapped with a protective shielding if necessary to prevent damage to the pipe coating during backfilling.

### **1.11 TRENCH BREAKERS**

Trench breakers will be installed as deemed necessary by Enbridge in sloped areas after the pipe has been lowered into the trench. Trench breakers protect against subsurface water flow along the pipe after the trench is backfilled. Trench breakers will be constructed with bags filled with rock-free subsoil or sand. They will be placed from the bottom of the trench to near the top of the trench, completely surrounding the pipe and must be properly keyed into the undisturbed trench walls (see Figures 9 and 10). The location for trench breakers will be based on field conditions including the degree and length of slope, presence of down slope sensitive resource areas such as wetland and waterbodies, and proximity to other features such as roads and/or railroads. The following conditions apply to the placement and installation of trench breakers unless otherwise directed by Enbridge:

- Trench breakers will be spaced as described for permanent berms (see section 1.7.10) or as otherwise specified by Enbridge.
- Trench breakers will be installed on slopes greater than 5 percent adjacent to streams, wetlands, or other waterbodies.
- Topsoil will not be used to construct trench breakers.
- Where the pipeline exits a wetland towards areas of lower relief, trench breakers will be installed where there is a potential for underground drainage along the pipe in order to prevent wetland or waterbody drainage.

The actual location of each trench breaker will be selected through coordination between Enbridge's EIs, Enbridge's Craft Inspectors, and the Contractor's Foreman for backfilling activities.

### **1.12 DRAIN TILE REPAIR**

Where drain tiles are cut during trenching, the locations will be flagged by the Contractor and the Contractor will notify the EI and/or Agricultural Inspector of the locations. The Contractor will probe each drain tile line that is crossed by the trench using a sewer rod or pipe snake (or equivalent), prior to backfilling, to determine if the tile lines were damaged during construction. Drain tiles damaged during construction will be repaired to their preconstruction condition or better. Additional information is provided in Enbridge's Agricultural Mitigation Plan (AMP).

### **1.13 UPLAND BACKFILLING**

Backfilling follows pipe installation and consists of replacing the material excavated from the trench. In areas where topsoil has been segregated, the subsoil will be replaced first, and the topsoil will be spread uniformly over the area from which it was removed. Prior to

backfilling, the trench shall be dewatered in accordance with the methods discussed in EMP section 5.0.

#### **1.14 WET WEATHER SHUTDOWN**

During construction, certain activities may be suspended in wet soil conditions, based on consideration of the following factors:

- plasticity of the surface soil to a depth of approximately 4 to 8 inches;
- extent of surface ponding;
- extent and depth of rutting and mixing of soil horizons;
- areal extent and location of potential rutting and compaction (i.e., can traffic be rerouted around wet area); and
- type of equipment and nature of the construction operations proposed for that day.

Additional requirements for working in agricultural land during wet conditions are included in Enbridge's AMP.

If the above factors cannot be achieved to the satisfaction of Enbridge, the Contractor will cease work in the applicable area until Enbridge determines that site conditions are such that work may continue.

The Contractor is responsible for appropriately planning for work, considering for the potential for wet conditions, and being prepared to implement mitigative measures in the event of wet weather conditions. This is particularly important when conducting work in unsaturated wetlands. The Contractor is responsible for implementing any and all such corrective measures should conditions subsequently worsen where the above described criteria cannot be met.

#### **1.15 CONTROLLING SPREAD OF UNDESIRABLE SPECIES**

It is Enbridge's intent to minimize the potential introduction and/or spread of undesirable species (i.e., invasive species and noxious weeds) along its ROW due to pipeline construction activities. However, it is not practicable for Enbridge to eradicate undesirable species that are adjacent to its ROW. Enbridge will minimize the potential for the establishment of undesirable species by minimizing the time duration between final grading and permanent seeding. Enbridge will also require that construction equipment be cleaned before arriving on site to prevent the introduction of undesirable species to the project area. A more detailed discussion of controls for noxious weeds is provided in Enbridge's Noxious Weed Plan.

#### **1.16 CLEANUP AND ROUGH/FINAL GRADING**

Initial cleanup and rough grading activities may take place simultaneously. Cleanup involves removing construction debris (including litter generated by construction crews and excess rock). Rough and final grading includes restoring disturbed areas as near as practicable to preconstruction conditions, returning the topsoil where topsoil has been stripped, preparing a seedbed (where applicable) for permanent seeding, installing or repairing temporary erosion control measures, repairing/replacing fences, and installing permanent erosion controls.

## 1.17 TIMING

The Contractor shall begin cleanup and rough grading (including installation of temporary erosion and sediment control measures) within 72 hours after backfilling. The Contractor shall attempt to complete this cleanup within one week, weather and soil conditions permitting.

Where two pipelines (Alberta Clipper and Southern Lights Diluent) are being installed, timing of cleanup and rough grade will be applicable after the installation of the second pipeline.

## 1.18 PERMANENT EROSION AND SEDIMENT CONTROLS

During final grading, slopes in areas other than cropland will be stabilized with erosion control structures (see Figure 11). Erosion control treatments of specific physical land features are described below.

### Slopes

Permanent berms (diversion dikes or slope breakers) will be installed on all slopes, according to the following maximum spacing requirements unless otherwise specified in permit conditions:

<u>Slope (%)</u>	<u>Approximate Spacing (ft)</u>
3-5	250
5-15	200
15-25	150
>25	<100

Permanent berms will be constructed according to the following specifications.

- Permanent berms will be installed with a 2 to 4 percent outslope.
- Permanent berms will be constructed of compacted earth.
- The outfall of berms will be directed toward appropriate energy-dissipating devices, and off the construction ROW if possible
- Permanent berms will be inspected and repaired as deemed necessary by Enbridge to maintain function and prevent erosion. Figures 5 and 6 illustrate berm specifications.
- Erosion control blankets (curlex, jute, or equivalent) will be placed on slopes over 30 percent (see Figure 12) or that are a continuous slope to a sensitive resource area (e.g., wetland or waterway).

## 1.19 SOIL COMPACTION TREATMENT

Cultivated fields and compacted or rutted areas will be tilled with a deep tillage device or chisel plowed to loosen compacted soils. If subsequent construction and cleanup activities result in further compaction, additional measures will be undertaken to alleviate the soil compaction. Additional information on soil compaction is provided in Enbridge's AMP.

## **1.20 STONE REMOVAL**

A diligent effort will be made to remove excess stones larger than 4 inches in diameter from the upper 8 inches of soil or as specified in permit conditions or landowner agreements. Stone removal efforts will cease when the size and density of stones on the ROW are similar to undisturbed areas adjacent to the ROW. Excess rock will be piled in upland areas where landowner permission has been obtained, or will be hauled off-site to an Enbridge approved disposal site. Additional information on stone removal is provided in Enbridge's AMP.

## **1.21 OFF-ROAD VEHICLE CONTROL MEASURES**

Off-road vehicle control measures will be installed as requested by Landowners or as directed by land management agencies at points of entry. Such measures may include installing fences and gates, or placement of other barriers such as boulders or timbers. Visual screening may also be installed to deter use of the pipeline corridor from unauthorized activities, if requested by the landowner. No Trespassing signs will be installed at aboveground facilities, according to the provisions of M.S. 609.6055 (Trespass on Critical Public Service Facility; Utility; or Pipeline) to provide clear notice to the public and protect the integrity of the pipeline. All fences and gates removed or damaged will be repaired or replaced.

## **1.22 REPAIR OF DAMAGED CONSERVATION PRACTICES**

All soil conservation practices (such as terraces, grassed waterways, etc.) that are damaged by the pipeline construction will be restored to preconstruction conditions to the extent practicable.

## **1.23 LAND LEVELING FOLLOWING CONSTRUCTION**

Following the completion of the pipeline, the ROW will be restored to its pre-construction conditions as practical. Should uneven settling or documented surface drainage problems occur following the completion of pipeline construction, Enbridge will take appropriate steps to remedy the issue.

Permanent soil erosion and sediment control will begin as soon as soil conditions permit seed bed preparation and seed germination. Actively cultivated lands will be restored but will not be reseeded unless requested by the landowner.

## **2.0 STREAM AND RIVER CROSSING GENERAL REQUIREMENTS**

Pre-construction planning is an essential part of stream crossings. Stream crossing requirements, including construction methods, timing, erosion control, and restoration are described in this section and in the stream crossing permits issued by state and federal agencies and by tribal authorities (as applicable). If the Contractor considers certain parts of these procedures to be technically impractical due to site-specific engineering constraints, the Contractor may seek modifications through the On-Site Modification Request Process. The On-Site Modification Request Process will be developed in conjunction with tribal, state, and federal regulatory agencies and may differ between states and will be provided in Enbridge's Construction Environmental Control Plans (CECP). Prior to construction, the Contractor must identify alternative provisions that would provide an equal or greater level of protection to stream and river ecosystems. Enbridge will review the Contractor's alternatives and consult with appropriate regulatory agencies and tribal resource specialists (as applicable). The Contractor must receive written approval from Enbridge prior to implementing the alternatives. The EI will confer with the IEM during wet and high runoff conditions to determine whether conditions warrant additional considerations for construction activities.

The procedures in this section apply to streams, rivers, and other waterbodies such as jurisdictional ditches, ponds, and lakes. These procedures require that judgment be applied in the field and will be implemented under the supervision of Enbridge. The intent of the mitigation procedures is to minimize construction-related disturbance to streams and waterbodies by limiting the duration of construction in these areas and by minimizing erosion and sedimentation.

### **2.1 TIME WINDOW FOR CONSTRUCTION**

In-stream trenching will be conducted during periods permitted by the appropriate regulatory agencies and applicable permits.

### **2.2 PRE-CONSTRUCTION CONSIDERATIONS**

#### **2.2.1 Hazardous Materials**

Hazardous materials, chemicals, fuels, lubricating oils, will not be stored and/or concrete coating activities will not occur within 100 feet of streams and waterbodies and in accordance with Enbridge's Spill Prevention, Containment and Control Plan (Spill Plan). Refer to the Spill Plan for additional requirements pertaining to hazardous materials and concrete-coating activities.

#### **2.2.2 Refueling/Equipment Care**

Construction equipment will be refueled at least 100 feet from streams and waterbodies. Where the Contractor and EI determines that conditions require construction equipment to be refueled within 100 feet of streams, the Contractor must follow the procedures described in Enbridge's Spill Plan and implement additional provisions based on site-specific conditions. No equipment will be washed within 100 feet of streams or waterbodies. Overnight parking of equipment is not allowed within 100 feet of a stream or waterbody unless special provisions have been implemented in accordance with Enbridge's Spill Plan. Maintenance (e.g., lubricating) of construction equipment will not be allowed within the 100 foot buffer zone without approval from the EI with additional special provisions for containment.



### **2.2.3 Alignment of Crossing**

Stream crossings will be designed as close to perpendicular to the axis of the stream channel as engineering and routing constraints allow, creating the shortest crossing length.

## **2.3 CLEARING AND GRADING**

The Contractor will leave a 20-foot buffer (from the ordinary high water mark (OHWM) / ordinary high water level (OHWL)) of undisturbed herbaceous vegetation on all stream banks during initial clearing, except where grading is needed for bridge installation, or where restricted by applicable regulations and/or permit conditions (such as impaired waterways). In Minnesota, the OHWL is defined as the boundary of water basins, watercourses, public waters, and wetlands and (1) an elevation delineating the highest water level that has been maintained for a sufficient period of time to leave evidence upon the landscape, commonly the point where the natural vegetation changes from predominantly aquatic to predominantly terrestrial; (2) for watercourses, the OHWL is the elevation of the top of the bank of the channel; and, (3) for reservoirs and flowages, the OHWL is the operating elevation of the normal summer pool (Minnesota Statutes, Section 103G.005, subdivision 14).

Woody vegetation within this buffer may be cut and removed during clearing, leaving the stumps and root structure intact. Non-woody vegetation and the soil profile will be left intact until the Contractor is ready to begin trenching the stream crossing. The Contractor will properly install and maintain sediment control measures at the 20-foot buffer line adjacent to streams immediately after clearing and prior to initial ground disturbance (see Figures 13A, 13B, 14A, 14B, 15A, 15B, and 16). This buffer should not be confused with the 50-foot setback required for extra workspace (see section 2.4).

### **Minnesota Impaired Waters**

In Minnesota, where discharges of stormwater may occur to waters designated under Section 303(d) of the Clean Water Act as Impaired Waters, additional BMPs will be implemented as indicated on the site-specific drawings provided in the Stormwater Pollution Prevention Plan. These additional measures may include the following:

- During construction all exposed soil areas with a slope of 3:1 or steeper and with a continuous positive slope to a designated Impaired Water must have temporary erosion protection or permanent cover within three (3) days after the area is no longer actively being worked. All other slopes with a continuous positive slope to an Impaired Water must have temporary erosion protection or permanent cover within seven (7) days after the area is no longer actively being worked.
- An undisturbed buffer zone of not less than 100 linear feet from the impaired water shall be maintained at all times, or until the water crossing is installed. In areas where the pre-construction vegetation provides less than a 100 foot buffer, the existing buffer will be maintained and documented unless otherwise directed by the applicable agency.

## **2.4 EXTRA WORKSPACE**

Extra workspaces, as defined in section 1.5, include work areas outside the boundary of the typical construction ROW. These spaces are typically used to assemble pipe segments and for temporary spoil storage. Clearing of forested and brushy areas for EWS will be avoided as

much as possible. Woody vegetation in wetlands and riparian areas will typically not be cleared for the purpose of EWS unless approved by appropriate regulatory agencies as stipulated in permits issued for the project. Extra workspaces will be constructed as follows:

- Extra workspaces will be located at least 50 feet away from the OHWM/OHWL if topographic or other physical conditions such as stream channel meanders allow (see Figures 13A, 13B, 14A, 14B, 15A and 15B).
- If safe work practices or site conditions do not allow for a 50-foot setback, extra workspaces should be located no closer than 20 feet from the OHWM/OHWL, subject to site-specific approval by Enbridge.
- Extra workspaces will be limited to the minimum size needed to construct the stream crossing.

## **2.5 BRIDGES**

Temporary equipment bridges will be used on most waterways (upon approval by the appropriate agency), including small waterways such as ditches and intermittent streams, where there is a potential for stormwater runoff or rain events to transport sediment downstream from equipment crossing the waterway. Bridges will be constructed as described below and will be removed as soon as possible during final restoration. Bridges will not typically be installed at directionally drilled waterbodies.

Clearing equipment and equipment necessary for installation of equipment bridges will be allowed a single pass across waterbodies prior to bridge installation, unless restricted by applicable permits.

### **2.5.1 Types of Bridges**

Equipment bridges will be constructed using one of the following techniques:

- Timber mats (see Figure 17)
- Rock Flume (see Figure 18)
- Railroad flat cars
- Other methods as approved by Enbridge and appropriate agencies

### **2.5.2 Bridge Design and Maintenance**

Bridges must be built and maintained in accordance with applicable permits. Equipment bridges will be designed to withstand the maximum foreseeable flow of the stream. Bridges will not restrict flow or pool water while the bridge is in place, and will be constructed with clean materials. Bridges will be designed and maintained to prevent soil from entering the waterbody. Soil that accumulates on the bridge decking will be removed as needed, or as deemed necessary by the EI. Where both the Alberta Clipper and Southern Lights Diluent pipelines will be constructed, bridges should be placed to accommodate installation of both pipelines without relocation, where practicable.

## 2.6 STREAM AND RIVER CROSSING CONSTRUCTION METHODS

The following stream and river crossing methods are typically used, subject to further restrictions by Enbridge and applicable permits and subject to modifications as approved by appropriate regulatory agencies and tribal resource specialists (as applicable) during construction. Only clearing equipment and equipment necessary to install equipment bridges will be allowed one opportunity to ford waters crossed by the project, unless otherwise restricted in applicable permits.

### 2.6.1 Wet Trench Method

#### Installation

The wet trench method will be used to cross streams and rivers not permitted to be flumed, dam and pumped, or directionally drilled (see Figures 13A and 13B). The following procedures will be used during wet trench crossings:

- Sediment control measures will be in place before grading from the 20-foot vegetative buffer left on each stream bank. Spoil containment structures will be installed back from the stream bank so that spoil does not migrate into the stream. Grading will be directed away from the waterbody to minimize the potential for sediment to enter the stream. Grading of stream banks will be restricted to the trench line and areas necessary for safe bridge installation.
- After grading, backhoes or draglines will be used to excavate the trench. Excavating equipment will operate from one or both banks, without entering the stream. If equipment must encroach into the stream, it will operate on clean construction mats. Streambed material will be segregated and placed within a spoil containment structure in approved construction work area limits.
- In-stream trenching and backfilling for each pipeline (separately) will typically be completed within 24 hours or less on minor waterbodies (<10 feet wide) and 48 hours or less on intermediate (>10 feet to 100 feet wide) or major waterbodies (>100 feet wide) (not including HDD crossings) or as directed by applicable permits.
- Earthen trench plugs (hard plugs) between the stream and the upland trench will be left undisturbed during excavation of the in-stream trench to prevent diversion of the stream flow into the open trench and to prevent water that may have accumulated in the adjacent upland trench from entering the waterbody. Trench plugs will be removed immediately prior to pipe placement, and then replaced when the pipe is in place. Trench water accumulated upslope of trench plugs must be dewatered appropriately prior to trench plug removal.
- If trench dewatering is necessary, the pump intake will be suspended off the trench bottom and dewatering will take place into a sediment filter bag and/or a straw bale dewatering structure (see Figures 19 and 20) where directed by Enbridge. The trench will be dewatered in such a manner that no heavily silt-laden water flows into streams or wetlands (see section 5.0). Only non-woven fabric will be used for filter bags.
- Backfilling will begin after the pipe is positioned in the trench at the desired depth. Backfill material will consist of the spoil material excavated from the trench and parent streambed unless otherwise specified in state or federal permits. The in-stream trench

will be backfilled so that the stream bottom is as near as practicable to its pre-construction condition, with no impediments to normal water flow.

## **Temporary Stabilization**

Enbridge will restore the stream banks as near as practicable to pre-construction conditions unless that slope is determined to be unstable (see section 2.8). Once the banks have been reshaped, ECDs will be installed within 24 hours of backfilling the crossing. Temporary slope breakers will be installed on all sloped approaches to streams in accordance with the spacing requirements outlined in section 1.7.10.

A temporary seed mix (e.g., annual rye or annual oats) and mulch and/or erosion control blankets will be installed within a 50-foot buffer on either side of the stream. Silt fence will be installed upslope of the temporary seeding area.

## **2.6.2 Dam and Pump Method**

### **Installation**

The dam and pump method is a dry crossing method that is suitable for low flow streams and is a preferred alternative to fluming for crossing meandering channels. The dam and pump method involves damming of the stream with sandbags, inflatable dams, and/or steel plates upstream and downstream of the proposed trench before excavation (see Figures 14A and 14B) and pumping water around the construction area. The following procedures will be used for dam and pump crossings:

- Pumping of the stream across the ROW will commence simultaneously with dam construction to prevent interruption of downstream flow. Stream flow will be pumped across the construction area through a hose and will be discharged to an energy-dissipation device, such as plywood boards, to prevent scouring of the streambed.
- The pumps will be located on the upstream side of the crossing and will be placed in impermeable, sided structures which will act as containment units for the pumps and fuel containers. The pumps used for the Dam and Pump crossing method will not be placed directly in the stream or on the streambed. Pumps will have a capacity greater than the anticipated stream flow. The pumping operation will be staffed 24 hours a day and pumping will be monitored and adjusted as necessary to maintain an even flow of water across the work area and near-normal water levels upstream and downstream from the crossing. A backup pump of equal or greater capacity will be on-site at all times in the event that the primary pump fails.
- Spill kits will be stored adjacent to pumps and fuel.
- Dams will be constructed of sandbags, inflatable dams, aqua-dams, and/or steel plates. The dams will prevent the stream from flowing into the construction area. The dams will be continuously monitored for a proper seal. Additional sandbags, plastic sheeting, steel plating, or similar materials will be used where necessary to minimize the amount of water seeping around the dams and into the construction work area.

- Backhoes located on one or both stream banks will excavate a trench across the stream bed. Streambed material will be segregated and placed within a spoil containment structure in approved construction work area limits. Existing streambed material will be segregated and placed within a spoil containment structure in approved construction work area limits.
- Trench (earth) plugs between the stream and the upland trench will be used during excavation of the in-stream trench to prevent diversion of the seeped groundwater into the open trench. Trench plugs will be removed immediately before pipe placement, and then replaced when the pipe is in place.
- Standing water that is isolated in the construction area by the dams will be pumped into a sediment filter bag and/or a straw bale dewatering structure located in such a manner that no heavily silt-laden water flows into streams or wetlands (see section 5.0). Only non-woven fabric will be used for filter bags.
- Backfilling will begin after the pipe is positioned in the trench to the desired depth. Backfill material will consist of the spoil material and parent streambed excavated from the trench unless otherwise specified in state or federal permits. The in-stream trench will be backfilled so that the stream bottom is similar to its pre-construction condition, with no impediments to normal water flow.

### **Temporary Stabilization**

Restoration of the ROW and the installation of temporary erosion controls will be similar to that described for the wet trench method above. Once the stream banks have been stabilized, the dams and pump will be removed.

### **2.6.3 Flume Method**

#### **Installation**

The flume method is a dry crossing method that is suitable for crossing sensitive, relatively narrow streams that have straight channels and are relatively free of large rocks and bedrock at the point of crossing. This method involves placement of flume pipe(s) in the stream bed to convey stream flow across the construction area without introducing sediment to the water (see Figures 15A and 15B). The procedures for using the flume method are described below.

- The flume(s) will be of sufficient diameter to transport the maximum flows anticipated to be generated from the watershed. The flume(s), typically 40 to 60 feet in length, will be installed before trenching and will be aligned so as not to impound water upstream of the flume(s) or cause downstream bank erosion. The flumes will not be removed until after the pipeline has been installed, trench has been backfilled, and the stream banks have been stabilized.
- The upstream and downstream ends of the flume(s) will be incorporated into dams made of sand bags and plastic sheeting (or equivalent). The upstream dam will be constructed first and will funnel stream flow into the flume(s). The

downstream dam will prevent backwash of water into the trench and construction work area. The dams will be continuously monitored for a proper seal. Adjustments to the dams will be made where necessary to prevent large volumes of water from seeping around the dams and into the trench and construction work area.

- After the stream bed is dewatered, backhoes located on one or both stream banks will excavate a trench across the stream bed. Spoil generated during trenching will be stored in a straw bale/silt fence containment area located away from the stream banks within approved construction work areas. Existing streambed material will be segregated and placed within a spoil containment structure in approved construction work area limits.
- Trench (earth) plugs between the stream and the upland trench will be used, during excavation of the in-stream trench to prevent diversion of the stream flow into the open trench or upland sediment flowing into the stream via the trench. Trench plugs will be removed immediately before pipe placement, and then replaced when the pipe is in place.
- If trench dewatering is necessary to complete the installation of the pipe, the discharge will be pumped into a sediment filter bag or a straw bale dewatering structure in such a manner that no heavily silt-laden water flows into streams or wetlands (see section 5.0). Non-woven fabric must be used for filter bags.
- Backfilling will begin after the pipe is positioned in the trench to the desired depth. Backfill material will consist of the spoil material excavated from the trench and parent streambed unless otherwise specified in state or federal permits. The in-stream trench will be backfilled so that the stream bottom is similar to its pre-construction condition, with no impediments to normal water flow.

### **Temporary Stabilization**

Restoration of the ROW and the installation of temporary erosion controls will be similar to that described for the wet trench method above. After the stream banks have been stabilized, the dams and flume will be removed from the stream bed allowing water to resume its flow in the channel.

## **2.6.4 Directional Drill and/or Guided Bore Method**

### **Installation**

Installing the pipe underneath a stream will involve placing a drill unit on one side of the stream (see Figure 16). A small-diameter pilot hole will be drilled under the stream along a prescribed profile. After the pilot hole has been completed, barrel reams will be used to enlarge the pilot hole to accommodate the desired pipeline diameter. Drilling mud will be necessary to remove cuttings and maintain the integrity of the hole. Water from an approved source (typically the river to be crossed) will be used to prepare the slurry of drilling mud, and will be appropriated according to applicable permits. The pipe section will be pulled through the hole by the drilling rig and welded to the adjoining sections of pipe on each side of the river.

## **Drilling Mud**

During drilling operations, drilling mud and slurry will be stored back from the river bank in an earthen berm sediment control structure, in tanks, or by other methods so that it does not flow into the stream, adjacent wetlands or off the workspace.

Enbridge has developed a contingency plan to address measures to be performed in the event of a release of drilling mud onto the ground surface or waterbody. See the Enbridge *Drilling Mud Containment, Response, and Notification Plan* for additional details.

After the pipe is in place, excess drilling mud and slurry will be spread over an upland area approved by Enbridge and the landowner, or hauled off site to an Enbridge approved disposal location.

## **Temporary Stabilization**

The directional drilling/guided bore method normally does not result in the disturbance of the stream banks or riparian vegetation, which reduces the potential for erosion and sedimentation at the stream crossing. Consequently, temporary erosion control measures that are installed at open-cut crossings typically are not necessary for drilled/bored crossings.

## **2.7 DRAINAGE DITCHES AND INTERMITTENT STREAMS**

Intermittent streams and agricultural ditches will typically be crossed using the wet trench method (see section 2.6.1) as specified in the applicable permits. For small, dry intermittent streams and agricultural drainage ditches, standard upland construction procedures may be used, which involve stringing, welding, excavating the trench with backhoes, installing the pipe in the trench, and backfilling the trench with native material. The banks of each crossing will be reshaped, mulched, and, if required, seeded in accordance with Enbridge's *Revegetation and Restoration Monitoring Plan* to stabilize the crossing until permanent erosion control is implemented. No refueling, fuel storage, or equipment maintenance is allowed within 100 feet of a drainage ditch or intermittent stream without approval from the EI with additional special provisions for containment. Where dry swales cross the right-of-way, silt fence or straw bales will be installed at the edge of the right-of-way to prevent the flow of sediment from the right-of-way.

## **2.8 PERMANENT RESTORATION**

### **Stream Banks**

Stream banks disturbed during installation of the pipelines will be stabilized with erosion control materials such as jute or equivalent and seeded in accordance with Enbridge's *Revegetation and Restoration Monitoring Plan*. Permanent stabilization will be initiated within 24 hours after installation of the crossing, unless site and permit conditions delay permanent installation. Where the banks have been disturbed, Enbridge will restore the slopes as near as practicable to pre-construction conditions unless that slope is determined to be unstable. Where the slope of the banks is determined to be unstable or has the potential to erode or fail, the banks will be reshaped to transition the disturbed areas into the natural stream bank with the intent to stabilize the bank and create a blended, natural appearance.

Berms or other sediment filter devices will be installed at the base of sloped approaches to streams greater than five percent and the outlet of the berm will be directed away from the stream into a well vegetated area (see Figures 5, 6, and 11). Temporary sediment control devices will remain in place until the area has stabilized and adequate revegetation has established.

### **2.8.1.1 Vegetative Bank Restoration**

Typically, waterbody banks will be restored as near as practicable to preconstruction conditions after backfilling is complete and will be seeded with an appropriate seed mix as specified in the *Revegetation and Restoration Monitoring Plan*. Erosion controls, (e.g. erosion control blankets, silt fences, etc.) will be installed as necessary based on site-specific conditions.

### **Installation of Wildlife Buffers in Minnesota**

Enbridge will reestablish suitable woody species in designated areas in order to reestablish wildlife travel corridors in riparian areas. Woody species will be chosen that are characteristic of the ecological zone of the crossing in consultation with appropriate regulatory agencies. Enbridge will maintain a 10-foot strip of herbaceous vegetation centered over each pipeline. The woody species to be planted between the pipelines (new and existing) will be allowed to grow up to 15 feet in height, after which time Enbridge may maintain the vegetation in accordance with operational standards. The replanting zone will extend across the new and existing permanent ROW, and up to 50 feet from the waterbody bank (see Figures 22A and 22B). The extent of replanting from the waterbody bank will be designed to correspond to the existing riparian zone, and as approved by the associated landowner.

### **2.8.1.2 Bioengineering Restoration**

Enbridge will plant willows and/or other suitable species (sometimes called "bioengineering") at select streambank locations where woody vegetation exists at the time of construction, and where installation of the pipeline creates unstable soil conditions due to either stream meanders or stream crossing angle. Enbridge will consult with the appropriate agencies to identify areas that may need the additional site stabilization. Species and planting densities will be determined on a site-specific basis.

### **2.8.1.3 Rock Riprap Restoration**

Unstable soils and/or site-specific factors such as stream velocity and flow direction may require additional restoration efforts, such as installation of rock rip-rap, to stabilize disturbed stream banks. Rock rip-rap will be used only where site-specific conditions require and where applicable state permits or approvals have been acquired. Geotextile fabric and rock riprap will be placed according to site and permit conditions (see Figure 21). Disturbed soils upslope and on either side of the riprap will be prepared for seeding according to the *Revegetation and Restoration Monitoring Plan* and other stream bank protection requirements.

### **2.8.1.4 Bridge Removal**

Equipment bridges will be removed during final cleanup or, if access is needed, after final cleanup and permanent seeding. Restoration of the bridge area will be completed upon bridge removal. Bridges installed for winter construction (if applicable) will be removed before spring break up.



### **2.8.1.5 Swales**

Swales will be restored as near as practicable to original conditions. Swales will be seeded and either mulched with straw or erosion control blankets will be installed to the perceivable top of bank for the width of the ROW.

### **2.8.1.6 Drainage Ditches and Intermittent Streams**

Drainage ditches and intermittent streams will be permanently restored and stabilized with erosion control blanket, permanent seeding, or other appropriate measures.

ISSUED FOR PERMITTING

### **3.0 WETLAND CROSSING GENERAL REQUIREMENTS**

Typical pipeline construction in wetlands will consist of clearing, stringing, trenching, dewatering, installation, backfilling, final grading, cleanup, and revegetation. However, due to the unstable nature of some wetland soils, construction activities may differ somewhat from those described for upland areas. Construction activities will be minimized in wetlands to the extent practicable. Enbridge will also use special construction techniques to minimize the disturbance to plants and soils and to protect wetland hydrology.

Pre-construction planning is an essential part of wetland crossings. Wetland crossing requirements, including construction methods, timing, erosion control, and restoration, are described in this section and in the wetland crossing permits issued by state and federal agencies and applicable tribes. If the Contractor considers certain parts of these procedures to be technically impractical due to site-specific engineering constraints, the Contractor may seek modifications via the On-Site Modification Request Process. The On-Site Modification Request Process will be developed in conjunction with state, tribal, and federal regulatory agencies and may differ between states. Prior to construction, the Contractor must identify alternative provisions that would provide an equal or greater level of protection to wetland ecosystems. Enbridge will review the Contractor's alternatives and consult with appropriate regulatory agencies. The Contractor must receive approval from Enbridge prior to implementing the alternatives.

The procedures in this section apply to all wetlands that will be affected by the project. These procedures require that judgment be applied in the field and will be implemented under the supervision of Enbridge and the EI. The intent of these procedures is to minimize construction-related disturbance and sedimentation of wetlands and to restore wetlands as nearly as possible to pre-existing conditions.

#### **3.1 WETLAND ACCESS**

The Contractor must use the construction ROW and only approved roads to access wetland areas.

#### **3.2 SPILL PREVENTION**

##### **3.2.1 Storage of Fuels and Other Materials**

No storage of hazardous materials, chemicals, fuels, and lubricating oils, and no concrete coating activities will be permitted in, or within 100 feet of, any wetland unless special provisions have been implemented in accordance with Enbridge's Spill Plan. Vehicles and equipment left on the ROW overnight must be parked at least 100 feet from a delineated wetland unless special provisions have been implemented in accordance with Enbridge's Spill Plan.

##### **3.2.2 Refueling, Fuel Handling, and Equipment Maintenance**

Construction equipment will be refueled in upland areas at least 100 feet from a wetland. Where the Contractor and EI determines that conditions require construction equipment (e.g., swamp hoe, trench dewatering pumps, or portable generators) to be refueled within 100 feet of a wetland, the Contractor must follow the procedures described in Enbridge's Spill Plan and implement additional provisions based on site-specific conditions. No equipment will be washed within 100 feet of streams or waterbodies. Overnight parking of equipment is not allowed within

100 feet of a wetland unless special provisions have been implemented in accordance with Enbridge's Spill Plan. Maintenance (e.g., lubricating) of construction equipment will not be allowed within the 100 foot buffer zone without approval from the EI with additional special provisions for containment.

### **3.3 CLEARING**

Clearing the construction ROW in wetlands will be similar to clearing in uplands. For construction to proceed, obstructions (e.g., trees, brush, and logs) need to be removed. Typically, low ground pressure equipment will be used, limiting disturbance to the wetland. When clearing in wetlands, the following restrictions apply:

- The construction ROW width will typically be limited to 125 feet.
- Vegetation and trees within wetlands will be cut off at ground level, leaving existing root systems intact; clearing debris will generally be removed from the wetland for disposal. Hydro-axe debris, or similar can be left in the wetland if spread evenly in the ROW to a depth not to exceed 1 inch in thickness and in a manner, as determined by the EI, which will allow for normal revegetation.

### **Extra Workspace in Wetlands**

Enbridge attempted to locate EWS outside of wetlands wherever practicable; however, EWS have been sited in select wetlands where the wetland is adjacent to a waterbody, road, railroads, foreign utility crossings, and/or pipeline cross-over. Clearing of forested wetlands for EWS will be avoided as much as possible. Woody vegetation in wetlands will not be cleared for the purpose of EWS unless approved by appropriate regulatory agency.

- Staging areas, additional spoil storage areas, and other additional work areas (EWS) will be located in upland areas at least 50 feet away from wetland boundaries (see Figures 23A and 23B), where safe work practices or site conditions permit. If site conditions do not permit a 50-foot setback, then these areas will be located as far away from the wetland as is practicable. Vegetation will not be cleared between these areas and the wetland in any event. No construction activities including vegetation clearing or earthwork will occur between the EWS and sensitive resource areas (wetlands or waterways).
- The size of the additional workspace areas will be limited to the minimum needed to construct the wetland crossing.

### **3.4 GRADING IN A WETLAND**

Grading in a wetland, if required, will be conducted in a manner consistent with applicable federal, state, and local permits. Grading activities will be confined to the area of the trench. Grading outside the trench will only be allowed where required to ensure safety and restore the ROW after backfilling the trench.

ECDs (e.g., silt fence) will be installed across the entire construction ROW upslope of the wetland boundary, where necessary, to prevent sediment flow into the wetland. Where wetlands are adjacent to the construction ROW and the ROW slopes toward the wetlands, ECDs will be installed along the edge of the construction ROW as necessary to prevent

sediment flow into the wetlands. ECDs will be installed along the edge of the construction ROW, as necessary, to contain spoil and sediment within the construction ROW through wetlands.

ECDs will be maintained in proper working order to prevent the flow of sediment into wetlands from spoil piles or sloped approaches that are adjacent to the wetlands. When the depth of sediment reaches one-third of the height of a sediment barrier, the barrier will be replaced and/or the sediment removed. Non-functional erosion and sediment control features must be repaired, replaced, or supplemented with functional materials within 24 hours of discovery, or as soon as field conditions allow the features to be repaired.

### **3.5 CONSTRUCTION MATTING**

Supplemental equipment supports, such as timber mats (see Figures 23A and 23B), will be used where necessary to provide temporary portable support for construction equipment and minimize soil compaction and/or soil mixing. No more than two layers of equipment mats will be used to support equipment on the construction ROW unless prior approval is obtained from Enbridge. The Contractor is responsible for having a sufficient number of construction mats to perform the work. Tree stumps, brush riprap, imported soil, and rock fill shall not be brought in to stabilize the ROW in wetlands. Timber riprap (also known as corduroy road) cannot be used without prior written approval from the company and the appropriate regulatory agencies. Pre-existing corduroy roads in wetlands may be used but may not be improved, maintained, restored, or replaced without site-specific authorization from applicable agencies. Subsoil excavated from the pipeline trench in the wetland may be placed on top of equipment mats for additional stabilization.

All timber mats, construction debris, and larger woody vegetative debris (greater than 1.5 inch diameter) will be removed during cleanup of wetlands.

### **3.6 TRENCHING**

Excavation of the pipeline trench in wetlands typically will be accomplished using backhoe excavators. The duration of open trench will be minimized to the extent possible.

#### **3.6.1 Topsoil Segregation**

Typically, when constructing in wetland areas without standing water, up to one foot of topsoil (organic layer) will be stripped from the trench line and stockpiled separate from trench spoil as described in section 1.7.8. In standing water wetlands, organic soil segregation is not typically practical; however, Enbridge will attempt to segregate as much of the organic layer as possible based on site/saturation conditions. If normally unsaturated wetlands are saturated at the time of construction, topsoil segregation will be attempted according to Figures 23A and 23B and based on recommendations from the EI and appropriate regulatory agencies.

#### **3.6.2 Trench Breakers**

Where the EI determines that the pipeline trench has the potential to drain or partially drain a wetland, trench breakers will be installed as necessary to maintain the original wetland hydrology.

### **3.7 PIPELINE INSTALLATION**

The following procedures are intended to minimize siltation and disturbance to wetlands during installation.

### **3.7.1 Push/Pull Method**

Large wetlands with standing water can generally not be crossed with typical crossing methods. In these areas, the pipeline will be assembled in an upland area and positioned in the trench using the "push-pull" and/or "float" techniques.

Usually this fabrication requires use of extra temporary workspace adjacent to the ROW. The trench will be dug by a backhoe (or equivalent) supported on timber mats. The prefabricated section of pipeline will then be pushed-pulled into position or floated across the wetland. When the pipeline is in position, floats, if used, will be removed and the pipeline will sink into position. The trench will then be backfilled and the wetland will be restored by a backhoe or similar equipment working from construction mats or by low ground pressure equipment.

### **3.7.2 Non-Winter Construction within Extremely Saturated Wetlands**

When completing construction within extremely saturated wetlands in non-frozen conditions, the Contractor will implement pipeline construction practices commonly used across the United States. Specialized equipment (e.g., floatation hoes) designed to operate in these unique conditions may be required to construct the pipelines.

Based on Enbridge's past experience, the non-cohesive soils in these wetlands will likely result in the trench being wider than the typical trench width. Because the pipelines are being installed adjacent to existing pipelines, maintaining the safety and integrity of the existing pipelines is a concern. Where necessary, Enbridge will implement a 40-foot offset and a 140-foot construction ROW between pipelines (new and existing) in anticipation of slumping soils during excavations. Refer to Figures 24 and 25 for typical right-of-way configurations in these select wetland conditions.

### **3.7.3 Temporary Erosion and Sediment Controls**

ECDs at approaches to wetlands will be installed as described in section 1.7.9 and 3.4, according to the specifications presented on Figures 7 and 8.

### **3.7.4 Concrete Coating**

Concrete will generally be mixed off-site, and concrete coated pipe will be transported to the ROW on trucks. If required, pre-fabricated concrete weights and/or saddlebag weights will also be used to provide negative buoyancy. Concrete weights will be manufactured off-site and transported to the ROW. Weights will be strung along the construction ROW, where necessary, until they are placed over the pipe within the excavated ditch. Limited mixing and coating activities may occur on the construction ROW for coating pipe joints and concrete weight repairs according to the concrete usage specifications in Enbridge's Spill Plan. Washing equipment used for mixing, pouring, casting, or coating will not be conducted within 100 feet of any wetland and will be conducted and contained in a leak-proof containment facility or impermeable liner. Erosion and sediment controls will be installed downslope of equipment wash areas where needed to capture sediments and minimize erosion from runoff. Concrete coating on the pipe must be cured for a minimum of 3 days prior to installation in a wetland due to potential toxic effects on wetland and aquatic biota.

### **3.8 BACKFILLING**

The Contractor shall restore wetlands as near as practicable to pre-construction conditions and must make a reasonable attempt to return the subsoil its pre-construction density. During backfilling of wetland areas, subsoil material removed from the trench during construction will be replaced so that the material is not mounded above the adjacent ground surface (undisturbed trench wall). Subsoil that exceeds the elevation of the ground adjacent to the trench will be removed from the wetland and disposed of in an upland area or approved disposal site. After the trench has been backfilled with subsoil, previously segregated topsoil will be spread over the trench area and mounded no more than 12 inches above the adjacent, undisturbed soil.

### **3.9 ROUGH GRADING, CLEANUP, AND TEMPORARY RESTORATION**

Cleanup and rough grading activities may take place simultaneously. Cleanup typically will involve removing construction debris and replacing fences removed during construction. Rough grading will include restoring original conditions within the disturbed areas (i.e., ditchline, spoil storage areas, and equipment travel lane) and installing or repairing temporary erosion control measures. Temporary slope breakers will be installed near the boundary between the wetland and adjacent sloped approaches, to prevent sediment flow into the wetland.

#### **3.9.1 Timing**

Cleanup and rough grading (including installation of temporary erosion control measures) will begin as soon as practical after the trench is backfilled, weather permitting.

#### **3.9.2 Temporary Stabilization**

Where necessary to prevent erosion, disturbed wetland areas will be stabilized by seeding with a temporary cover in accordance with Enbridge's *Revegetation and Restoration Monitoring Plan*

No fertilizer, lime, or mulch will be applied in wetlands. Enbridge does not propose permanent planting or seeding in wetlands, except in accordance with restoration and compensatory mitigation plans and procedures that are being developed in cooperation with the U.S. Army Corps of Engineers.

## **4.0 HIGHWAY, ROAD AND RAIL CROSSINGS**

### **4.1 ADDITIONAL WORKSPACE**

Additional workspaces for bored road and railroad crossings and open-cut road crossings will be determined on a site-specific basis. These workspaces will be adjacent to the road or railroad and limited to the size needed to contain spoil from the crossing.

### **4.2 MAINTENANCE**

Roadway crossings will be maintained in a condition that will prevent tracking of mud onto the roadway. If mud is tracked onto a roadway, the Contractor shall remove accumulated material from the road and place within a sediment barrier as soon as possible, but in no circumstances more than 24 hours after discovery.

Rock tracking pads, constructed of stone no smaller than 4-inch or as required by the applicable permits, will be installed adjacent to paved public roads to prevent or minimize the tracking of soil onto the roadway. If the roadside ditch is part of a jurisdictional waterway, a permit must be obtained prior to installing the tracking pad or culvert. If permitted in wetlands, tracking pads will be limited in size to reduce impacts. Tracking pads installed in wetlands must be constructed with clean rock placed on geotextile fabric. All rock and fabric must be removed from the wetland during cleanup.

### **4.3 TEMPORARY EROSION AND SEDIMENT CONTROLS**

Temporary ECDs (e.g., silt fence and/or double-staked straw bales) will be installed on sloped approaches to road crossings where vegetation has been disturbed (see Figures 26A and 26B) as discussed in section 1.7.9.

## 5.0 CONSTRUCTION DEWATERING

### 5.1 TRENCH DEWATERING

The following additional guidance is being provided regarding dewatering activities to employ the maximum amount of reasonable protective measures to wetland and waterbody locations.

At each location where dewatering is to be conducted, the contractor must consider the following conditions in planning the dewatering event. Prior to initiating dewatering activities, the environmental inspector shall check the water discharge situation to ensure that the best management practices are applied in such a way as to minimize the potential for water containing sediment from reaching a waterbody.

1. **Water Discharge Setting** – The contractor shall assess each water discharge situation to include:
  - a. Soil Type - The soil type the discharged water would flow over. The management of discharged water traveling over sandy soil is more likely to soak into the ground as compared to clay soils.
  - b. Ground Surface - The topography in the area that would influence the surface flow of the discharged water.
  - c. Adjustable Discharge rate - The flow rate of the discharged water (which may need to vary) can be managed based on the site conditions to minimize instances of water from reaching a waterbody. (Example - Water discharged at 500 gallons per minute may soak into the ground while if discharged at a higher flow rate would cause water to flow via overland runoff into a waterbody)
  - d. Discharge Outfall - The amount of hose (utilizing up to 300 feet) needed to attempt to discharge water at a location which drains away from waterbodies or wetlands.
2. **Pump Intake** - Use floating suction hose or other similar measures to prevent sediment from being sucked from bottom of trench.
3. **Overwhelming Existing Drainage** - If the discharge (assumed to be clean) does enter a stream, the flow added to the stream cannot exceed 50 percent of the peak storm event flow (to prevent adding high water volumes to a small stream channel that causes erosion due to imposing high flow conditions on the stream).
4. **Filtering Mechanism** – All dewatering discharges will be directed through a filtering device as indicated below.
  - a. Well-Vegetated Upland Area – Water can be directed to a well-vegetated upland area through a geotextile filter bag. The ground at the discharge location shall be protected with a sheet of plywood or similar means to prevent scouring/erosion of the ground surface at the end of the discharge hose. Geotextile bags need to be sized appropriately for the discharge flow and suspended sediment particle size.
  - b. Straw Bale Dewatering Structure – Where the dewatering discharge point cannot be located in an upland area due to site conditions and/or distance, the discharge should be directed into a straw bale dewatering structure. The



size of the straw bale dewatering structure is dependant on the maximum water discharge rate. The size of the structure is dictated on the Typical Straw Bale Dewatering Figure (see figure 20). A straw bale dewatering structure should be used in conjunction with a geotextile filter bag to provide additional filtration near sensitive resource areas.

- c. Alternative dewatering methods (e.g., use of water canons) may be approved by Enbridge on a site-specific basis.

### **5.1.1 Regulatory Notification and Reporting**

Enbridge will notify appropriate tribal, state and federal agencies as required by all permits/authorizations.

Reports regarding the volume and quality of the water withdrawn and discharged will be submitted by Enbridge, as required by the applicable state and/or tribal permits. The Contractor will assist Enbridge in collecting appropriate data and any water samples required or in determining volumes of water appropriated.

### **5.1.2 Flow Measurement**

The volume of water discharged from the trench must be recorded as required by the applicable permits. The volume may be determined using a flow meter, or equivalent method as dictated by permit stipulations.

### **5.1.3 Water Sampling**

Water discharged from trench dewatering locations may need to be sampled as required by tribal permits and/or state-issued NPDES discharge permits. If required, the Contractor will assist Enbridge in obtaining these samples and will be responsible for complying with the permit limitations.

## **5.2 HYDROSTATIC TEST DISCHARGES**

Hydrostatic testing involves filling the new pipeline segments with water acquired in accordance with applicable permits (see section 6.0), raising the internal pressure level, and holding that pressure for a specific period of time per federal Department of Transportation specifications. Hydrostatic testing will be done to verify that there are no flaws in the pipe or welds. Pre-built sections may be hydrostatically tested prior to installation at significant streams and wetland crossings. Water used for hydrostatic testing will be discharged back to the waterbody it was appropriated from. After the hydrostatic test is completed, the line will be depressurized and the water expelled. During withdrawal and discharge, the water will be sampled as required by permits. Water volumes must be measured and recorded.

If site conditions or engineering constraints make adhering to these hydrostatic testing procedures and documentation impractical, Enbridge will propose alternative provisions to the regulatory agency issuing the NPDES permit and/or applicable tribal permits. Any such alternative will provide an equal or greater level of protection to the environment than the condition from which Enbridge or its Contractor seeks relief.

### **5.2.1 Refueling**

The operation and refueling of hydrostatic test equipment will be in accordance with the conditions outlined in Enbridge's Spill Plan.

## **5.2.2 Permit Requirements**

Hydrostatic testing will be conducted in accordance with applicable appropriation and discharge permits obtained by Enbridge. Hydrostatic test waters will not be transferred from one waterbody to another, across watershed, or major drainage divides. Chlorinated source water will be sampled at appropriation. If chlorine levels are at or above aquatic toxicity standards, the water will not be discharged to a surface water.

## **5.2.3 Siting of Test Manifolds**

Hydrostatic test manifolds will be installed where necessary to ensure proper test pressures. However, the selected location of test manifolds is based on engineering requirements to meet proper test pressures and incorporates changes due to topography. Where feasible, Enbridge will incorporate minor adjustments to the test manifold locations to avoid placement in wetlands and riparian areas. However, completely avoiding the placement of a test manifold in a wetland may not always be possible. The Contractor shall install appropriate erosion control measures where the EI determines that topographic conditions, primarily elevation changes, require test sections to be located in a wetland or riparian area.

## **5.2.4 Water Sampling**

Water discharged from hydrostatic tests will be sampled as required by state-issued appropriation or discharge permits. Hydrostatic water discharges will comply with permit limitations as required by the applicable NPDES/SDS permit and tribal permit (where applicable) conditions. If required, the Contractor will assist Enbridge in obtaining these samples and will be responsible for complying with the permit limitations.

## **5.2.5 Best Management Practices**

Prior to hydrostatic testing the pipeline, Enbridge will prepare the pipe by removing accumulated construction debris, mill scale, dirt, and dust using a cleaning pig. The debris will be collected in a temporary receiver and shall be properly disposed of by the Contractor. Upon completion of the cleaning operation, the pipeline will be sealed with the test headers.

Test headers and pigs will be arranged to allow for rinse water to be installed ahead of the fill pigs. Rinse water must be treated and disposed of in accordance with applicable permit conditions.

Following testing, the test section will be depressurized and the water will be discharged to a well-vegetated, upland area or an appropriate dewatering structure. Dewatering structure include geotextile filter bags and/or a hay bale structure that may or may not be lined with geotextile fabric. Direct discharges to surface waters will be directed with an energy dissipation device such as a splash pup.

At no time will the discharge rate exceed the applicable discharge rates specified in state-issued or other discharge permits. In the event no maximum discharge rate is identified, discharges shall be monitored and adjusted as necessary to avoid scouring or sediment transport from the discharge location.

To minimize the potential for introduction and/or spread of invasive species due to hydrostatic testing activities, Enbridge proposes to discharge water to the same source location from which it was appropriated. If water is used to test multiple test sections, it will be relayed back to the source water through the pipeline for final discharge. Test water will not be

discharged to a waterbody other than the appropriation source, unless coordinated and permitted through the applicable agencies.

In North Dakota and Minnesota, Enbridge will clean hydrostatic test equipment (e.g., pumps, hoses, piping, splash pups, etc.) by inspecting equipment for mud and vegetation debris and draining any lake or river water from the equipment. In addition, Enbridge will implement one of the following additional provisions for cleaning hydrostatic testing equipment when the air temperature is above 19 degrees Fahrenheit at the time the decontamination procedures take place:

- Allow equipment to dry thoroughly for not less than 5 days between usage at other hydrotesting sites prior to transport between test sites;
- Wash equipment with hot water (temperature not less than 212 degrees Fahrenheit);
- Wash equipment with soap and water or high pressure water of not less than 2,000 pounds per square inch pressure;
- Disinfect equipment with 200 parts per million (0.5 ounces per gallon) chlorine for not less than 10 minutes contact time; or,
- Disinfect with another approved disinfectant.

#### **5.2.6 Flow Measurement**

The total volume of water discharged will be determined with a flow meter (or equivalent), or as required by the applicable state permit. The total volume of water discharged will not exceed the volume specified in the applicable permit.

## **6.0 WATER APPROPRIATION**

### **6.1 GENERAL**

Water may be drawn from local sources, such as lakes, streams, and private or municipal wells for construction activities such as dust control, horizontal directional drilling/guided boring, trench dewatering, and hydrostatic testing. The project will follow applicable permit conditions for the appropriation of water.

Where water is appropriated from lakes or streams, the intake hose will be suspended off of the stream or lake bottom and will be screened to prevent entrainment of fish. During withdrawal, adequate waterbody flow rates and volumes will be maintained to protect aquatic life and allow for downstream uses. The volume and rate of withdrawal will be monitoring to comply with applicable permit conditions.

### **6.2 WATER SOURCES**

Water will only be withdrawn from sources approved by Enbridge and in accordance with applicable permits. No additives to the water are permitted unless written approval is received from Enbridge and applicable permits authorize such additives.

If appropriation is scheduled to occur during possible periods of low flow, including frozen conditions, a backup source will be identified.

### **6.3 FLOW MEASUREMENT**

At no time will the withdrawal rate for the water source exceed the rate specified in the applicable permits.

The withdrawal rate and total volume of water appropriated must be measured with a flow meter (or equivalent) and recorded as required by the applicable permits.

### **6.4 WATER SAMPLING**

Where required by permit conditions, Enbridge will sample the water during appropriation. The Contractor will assist Enbridge in obtaining these samples.

### **6.5 REGULATORY NOTIFICATION AND REPORTING**

Enbridge will notify appropriate agencies of the time of appropriations if required by the state appropriations permits. Reports regarding the volume and quality of the water withdrawn will be submitted by Enbridge if required by the applicable permits.

## 7.0 REVEGETATION

Permanent revegetation will involve preparing the seedbed and seeding disturbed, non-agricultural areas. The ROW will be seeded as soon as possible after backfilling, weather and soil conditions permitting. With the exception of wetland areas, fertilizer and pH modifying agents (e.g., lime) will be applied as specified by Enbridge, in consultation with appropriate state and federal agencies and Landowners. Refer to Enbridge's *Revegetation and Restoration Monitoring Plan* for specific information.

## 8.0 WINTER CONSTRUCTION

Summer construction of large diameter pipelines in saturated/standing water wetlands with unconsolidated soils can be difficult and potentially result in greater wetland disturbance including wider trench widths and extensive rutting/surface disturbance. Constructing across these types of wetlands in the winter can result in fewer impacts. Heavy construction equipment use and travel along the ROW, which may not be possible in summer conditions due to saturated, unstable soil conditions, can be accomplished in the winter by establishing temporary winter frost/ice roads. These frost/ice roads protect underlying vegetation and upper layers of wetland surfaces from disturbance potentially created during summer construction.

Enbridge evaluated the ROW workspace requirements needed to safely and efficiently construct through these wetland complexes during the winter, while maintaining the safety and integrity of the existing, adjacent pipelines. Based on this analysis, Enbridge is proposing to use a 140-foot-wide construction ROW in the two identified winter construction areas. This increased ROW width would allow Enbridge to:

- Maintain a 40 foot spacing between the existing outermost pipeline and the 20-inch diameter Southern Lights pipeline (inside line)
- Maintain a 40 foot spacing between the 20-inch diameter Southern Lights pipeline and the 36-inch Alberta Clipper pipeline (outside line)
- Maintain a 60 foot spacing between the 36-inch diameter Alberta Clipper pipeline and the outside edge of the construction ROW boundary.
- The spacing from the existing outermost pipeline to the edge of the new ROW may vary in certain situations depending on specific site conditions at the time of construction.

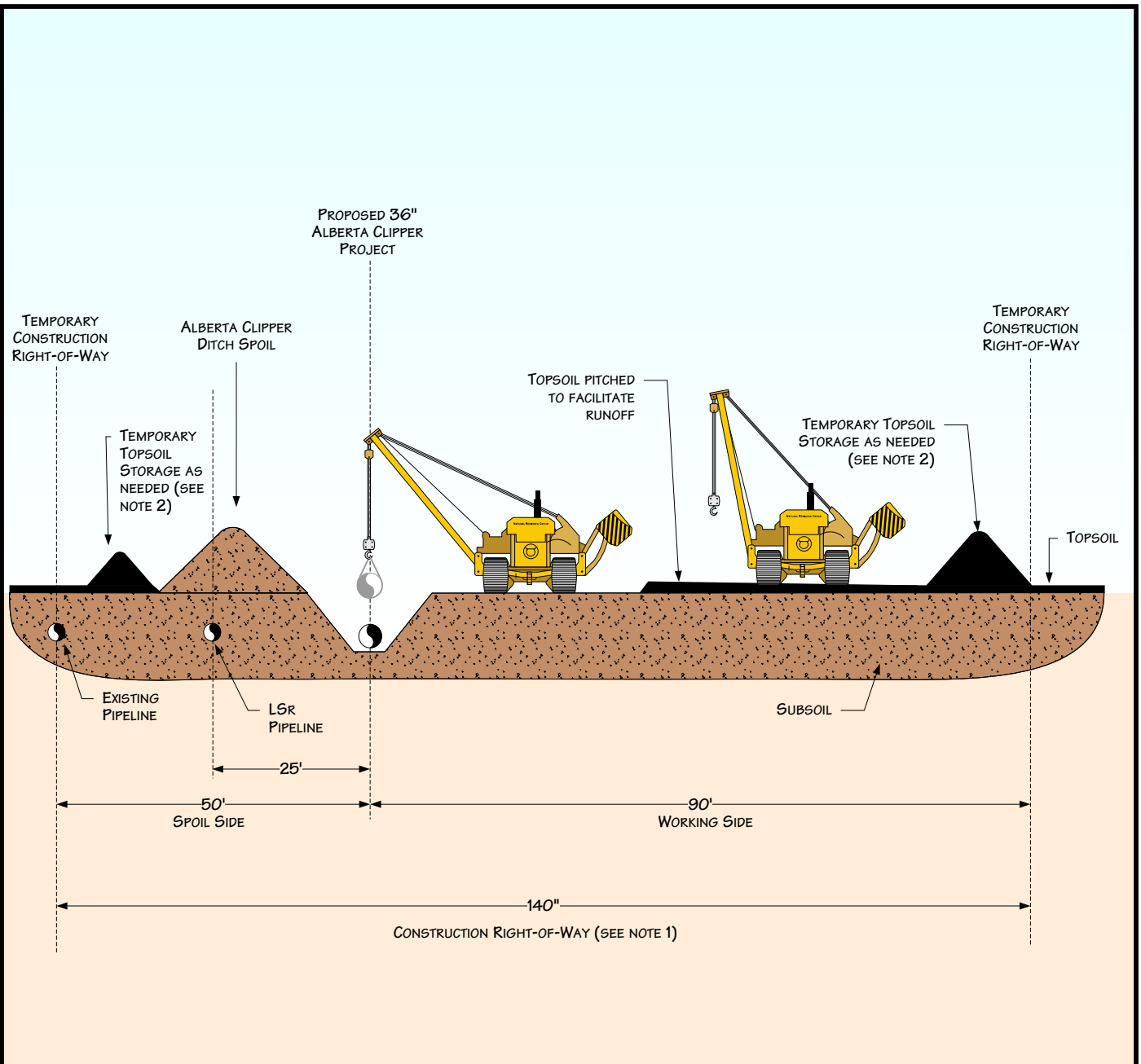
Typical cross section drawings of the proposed 140-foot-wide construction ROW configuration and the permanent 105-foot-wide ROW are shown in Figures 27, 28, 29, 30, and 31. These figures depict the 140-foot-wide construction ROW and the details of the frost/ice road needed to allow the construction equipment to work in the wetland areas and install the large diameter pipelines within the required spacing.

Additional winter construction details are provided in Enbridge's *Winter Construction Plan*.

**Minnesota and North Dakota  
Environmental Mitigation Plan**

**Figures**

ISSUED FOR PERMITTING



**PROFILE**

**NOTES:**

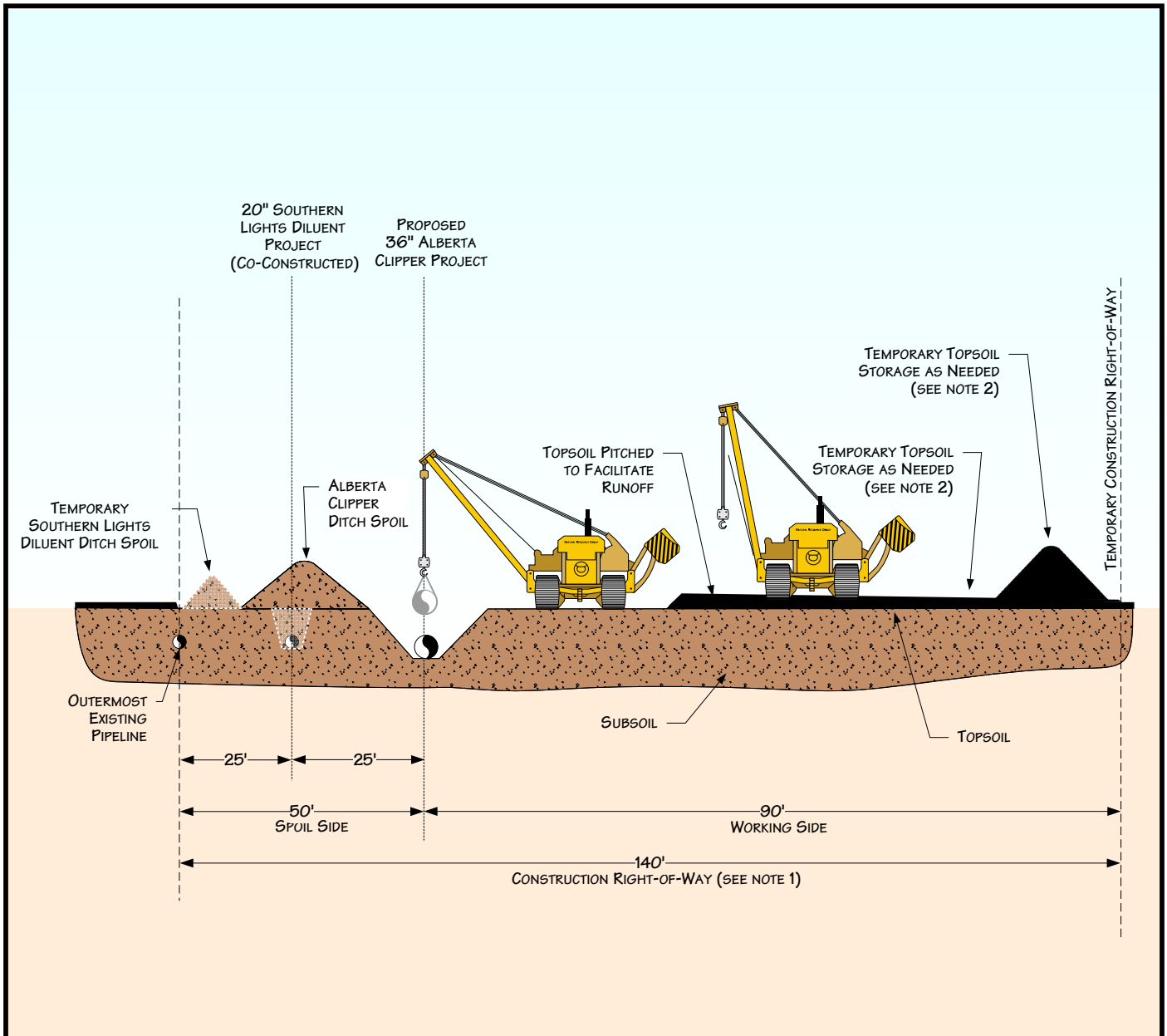
1. CONSTRUCTION RIGHT-OF-WAY WILL TYPICALLY BE 140' WIDE. THE SPOIL SIDE WILL BE APPROXIMATELY 50' WIDE AND GENERALLY WITHIN THE EXISTING MAINTAINED RIGHT-OF-WAY. THE WORKING SIDE WILL BE 90' WIDE.
2. STOCKPILE TOPSOIL SEPARATELY FROM DITCH SPOIL AS SHOWN OR IN OTHER CONFIGURATIONS APPROVED BY THE COMPANY.
3. THE OFFSET FROM NORTHERNMOST OR SOUTHERNMOST EXISTING PIPELINE, WHERE APPLICABLE, WILL BE 25' FOR MOST LOCATIONS BUT MAY BE INCREASED OR DECREASED DEPENDING ON THE SITE SPECIFIC CONSTRUCTION REQUIREMENTS.

For environmental review purposes only.



**Figure 1A**  
**Environmental Mitigation Plan**  
 Typical Construction Layout  
 (Neche, ND to Clearbrook, MN)

DATE: 7/9/2001	
REVISED: 1/19/2009	
SCALE: NTS	
DRAWN BY: KMKENDALL	
K:\335\MN_EMP\FIGURE01A.VSD	



**PROFILE**

**NOTES:**

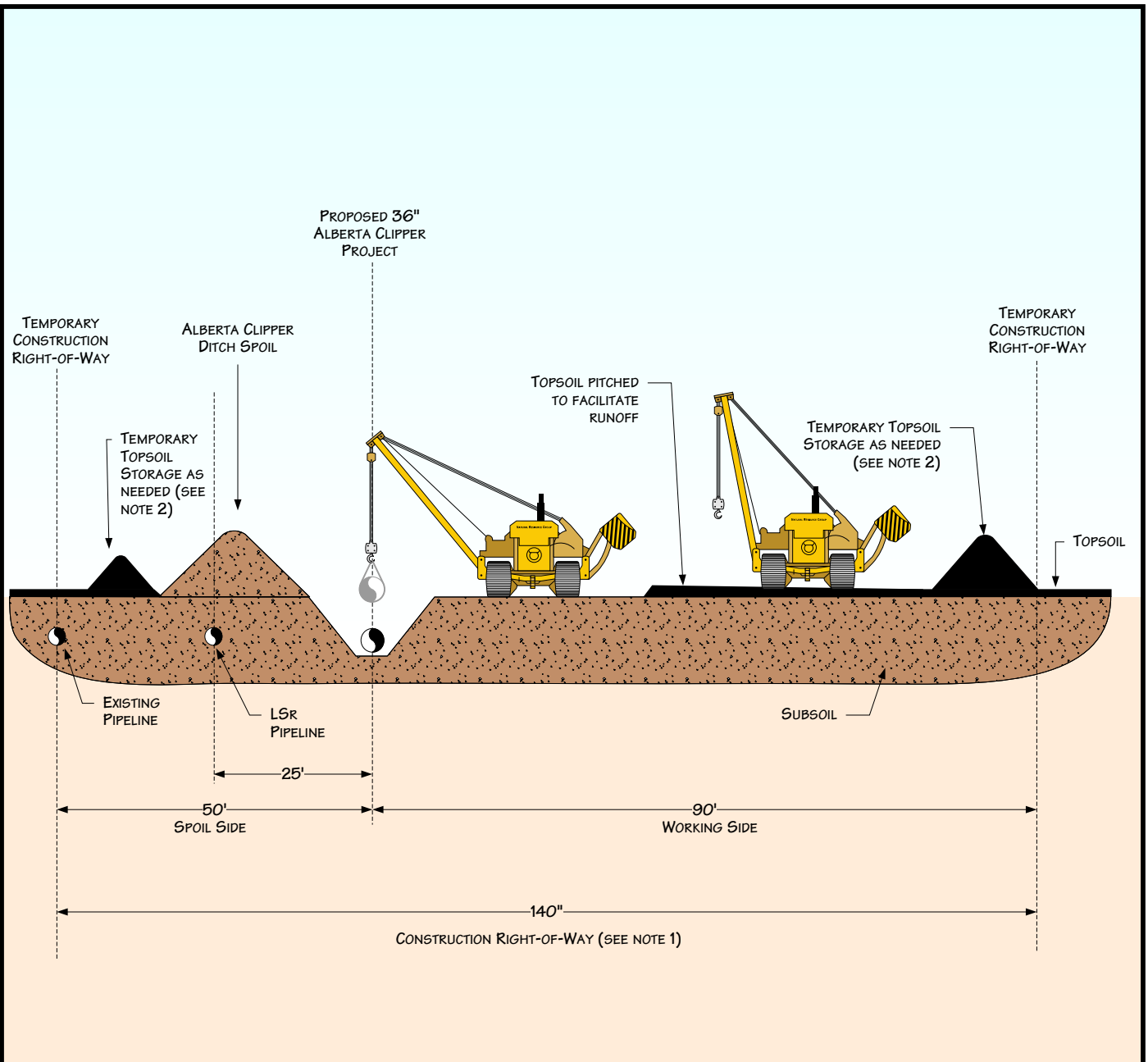
1. CONSTRUCTION RIGHT-OF-WAY WILL TYPICALLY BE 140' WIDE. THE SPOIL SIDE WILL BE APPROXIMATELY 50' WIDE AND GENERALLY WITHIN THE EXISTING MAINTAINED RIGHT-OF-WAY. THE WORKING SIDE WILL BE 90' WIDE.
2. STOCKPILE TOPSOIL SEPARATELY FROM DITCH SPOIL AS SHOWN OR IN OTHER CONFIGURATIONS APPROVED BY THE COMPANY.
3. THE OFFSET FROM NORTHERNMOST OR SOUTHERNMOST EXISTING PIPELINE, WHERE APPLICABLE, WILL BE 25' FOR MOST LOCATIONS BUT MAY BE INCREASED OR DECREASED DEPENDING ON THE SITE SPECIFIC CONSTRUCTION REQUIREMENTS.



**Figure 1B**  
**Environmental Mitigation Plan**  
 Typical Construction Layout  
 (Clearbrook, MN to Superior, WI)

DATE: 7/9/2001	
REVISED: 1/16/08	
SCALE: NTS	
DRAWN BY: KMKENDALL	
K:\335\MN_EMP\FIGURE01B.VSD	





**PROFILE**

**NOTES:**

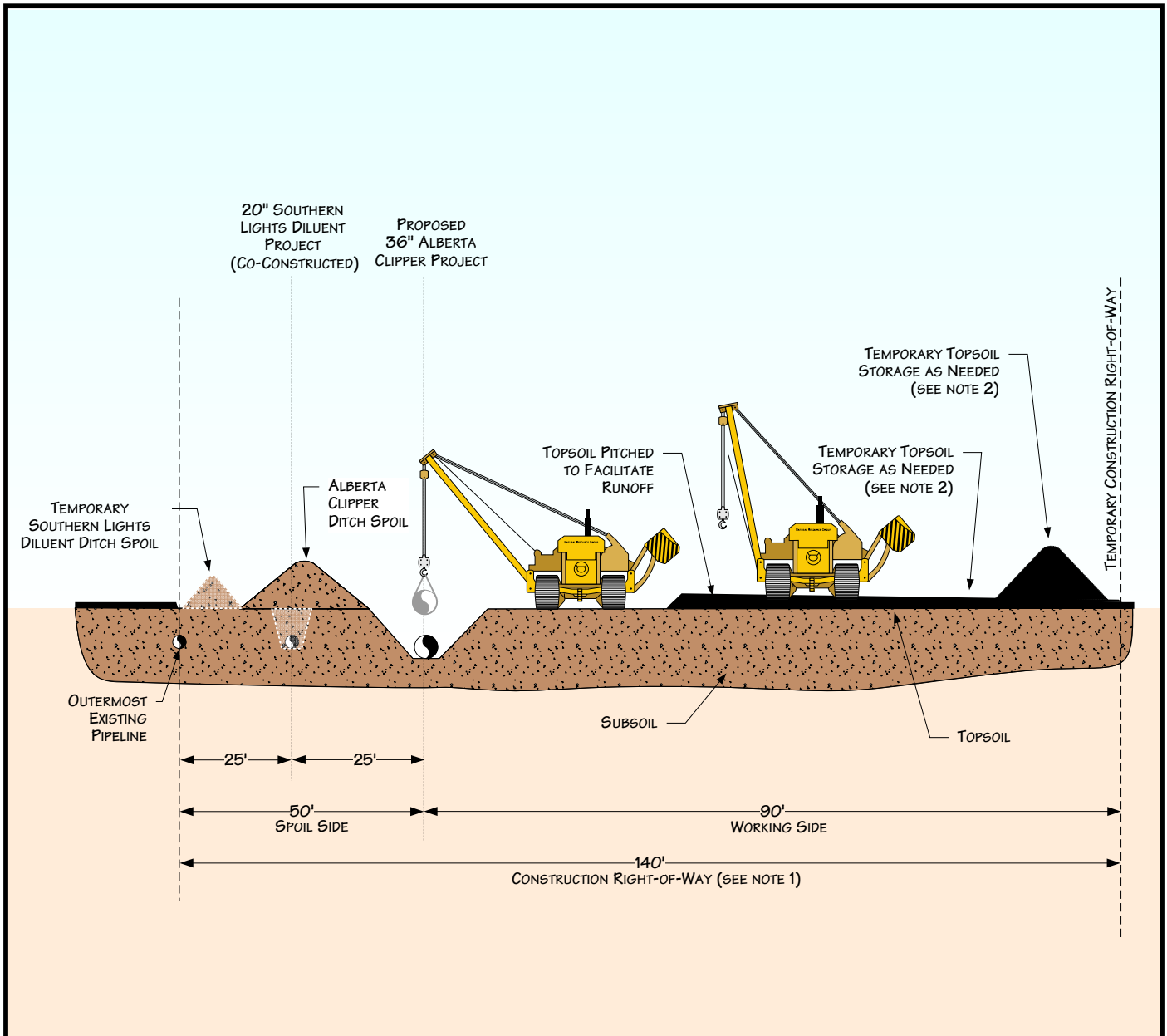
1. CONSTRUCTION RIGHT-OF-WAY WILL TYPICALLY BE 140' WIDE. THE SPOIL SIDE WILL BE APPROXIMATELY 50' WIDE AND GENERALLY WITHIN THE EXISTING MAINTAINED RIGHT-OF-WAY. THE WORKING SIDE WILL BE 90' WIDE.
2. STOCKPILE TOPSOIL SEPARATELY FROM DITCH SPOIL AS SHOWN OR IN OTHER CONFIGURATIONS APPROVED BY THE COMPANY.
3. THE OFFSET FROM NORTHERNMOST OR SOUTHERNMOST EXISTING PIPELINE, WHERE APPLICABLE, WILL BE 25' FOR MOST LOCATIONS BUT MAY BE INCREASED OR DECREASED DEPENDING ON THE SITE SPECIFIC CONSTRUCTION REQUIREMENTS.

For environmental review purposes only.



**Figure 2A**  
**Environmental Mitigation Plan**  
 Typical Topsoil Segregation  
 Modified Ditch Plus Spoil Side  
 (Neché, ND to Clearbrook, MN)

DATE: 7/9/2001	
REVISED: 1/19/2009	
SCALE: NTS	
DRAWN BY: KMKENDALL	
K:\1335\MN_EMP\FIGURE02A.VSD	



**PROFILE**

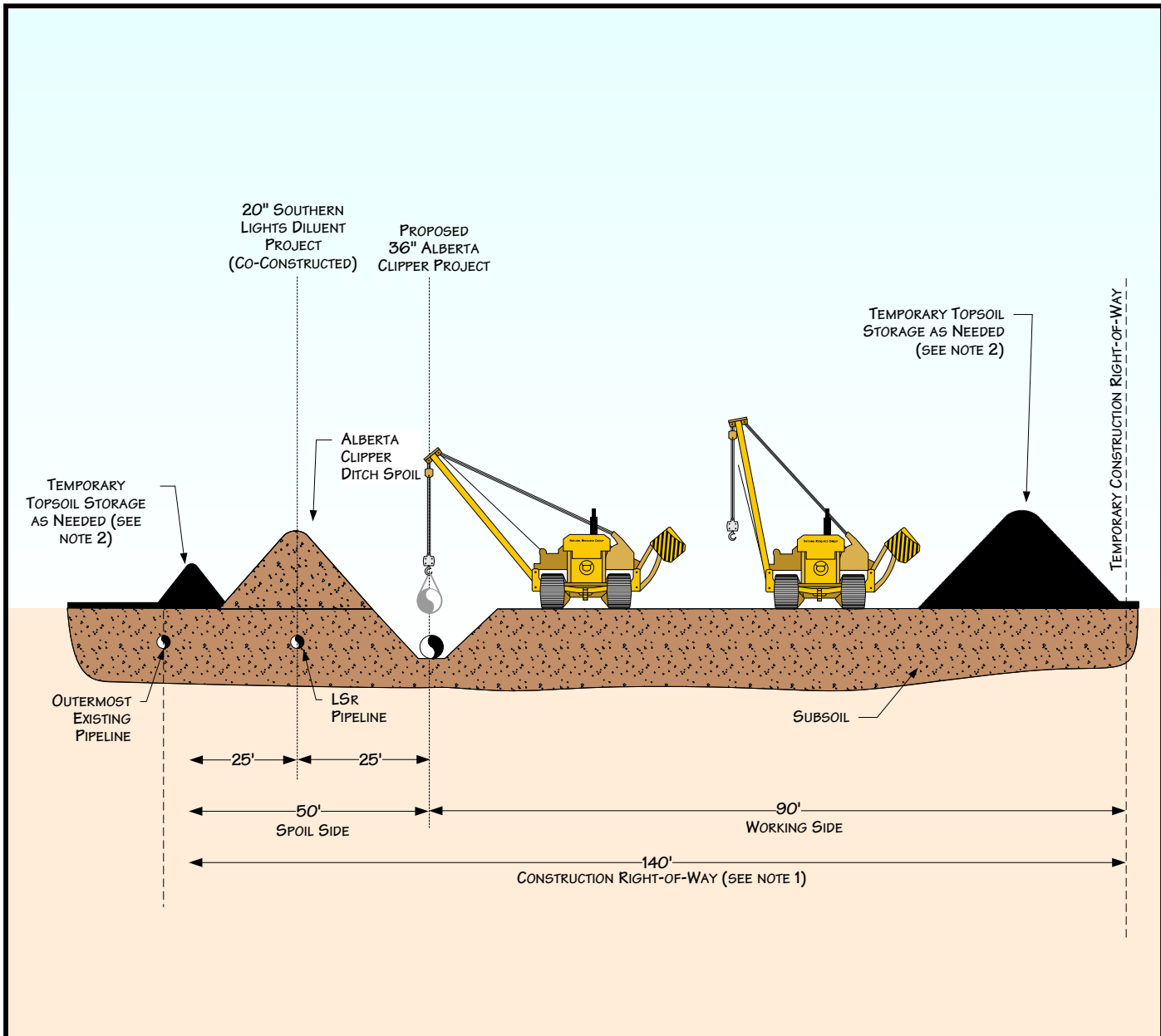
**NOTES:**

1. CONSTRUCTION RIGHT-OF-WAY WILL TYPICALLY BE 140' WIDE. THE SPOIL SIDE WILL BE APPROXIMATELY 50' WIDE AND GENERALLY WITHIN THE EXISTING MAINTAINED RIGHT-OF-WAY. THE WORKING SIDE WILL BE 90' WIDE.
2. STOCKPILE TOPSOIL SEPARATELY FROM DITCH SPOIL AS SHOWN OR IN OTHER CONFIGURATIONS APPROVED BY THE COMPANY.
3. THE OFFSET FROM NORTHERNMOST OR SOUTHERNMOST EXISTING PIPELINE, WHERE APPLICABLE, WILL BE 25' FOR MOST LOCATIONS BUT MAY BE INCREASED OR DECREASED DEPENDING ON THE SITE SPECIFIC CONSTRUCTION REQUIREMENTS.



**Figure 2B**  
**Environmental Mitigation Plan**  
 Typical Topsoil Segregation  
 Modified Ditch Plus Spoil Side  
 (Clearbrook, MN to Superior, WI)

DATE: 7/9/2001	
REVISED: 1/16/08	
SCALE: NTS	
DRAWN BY: KMKENDALL	
K:\335\MN_EMP\FIGURE02B.VSD	



**PROFILE**

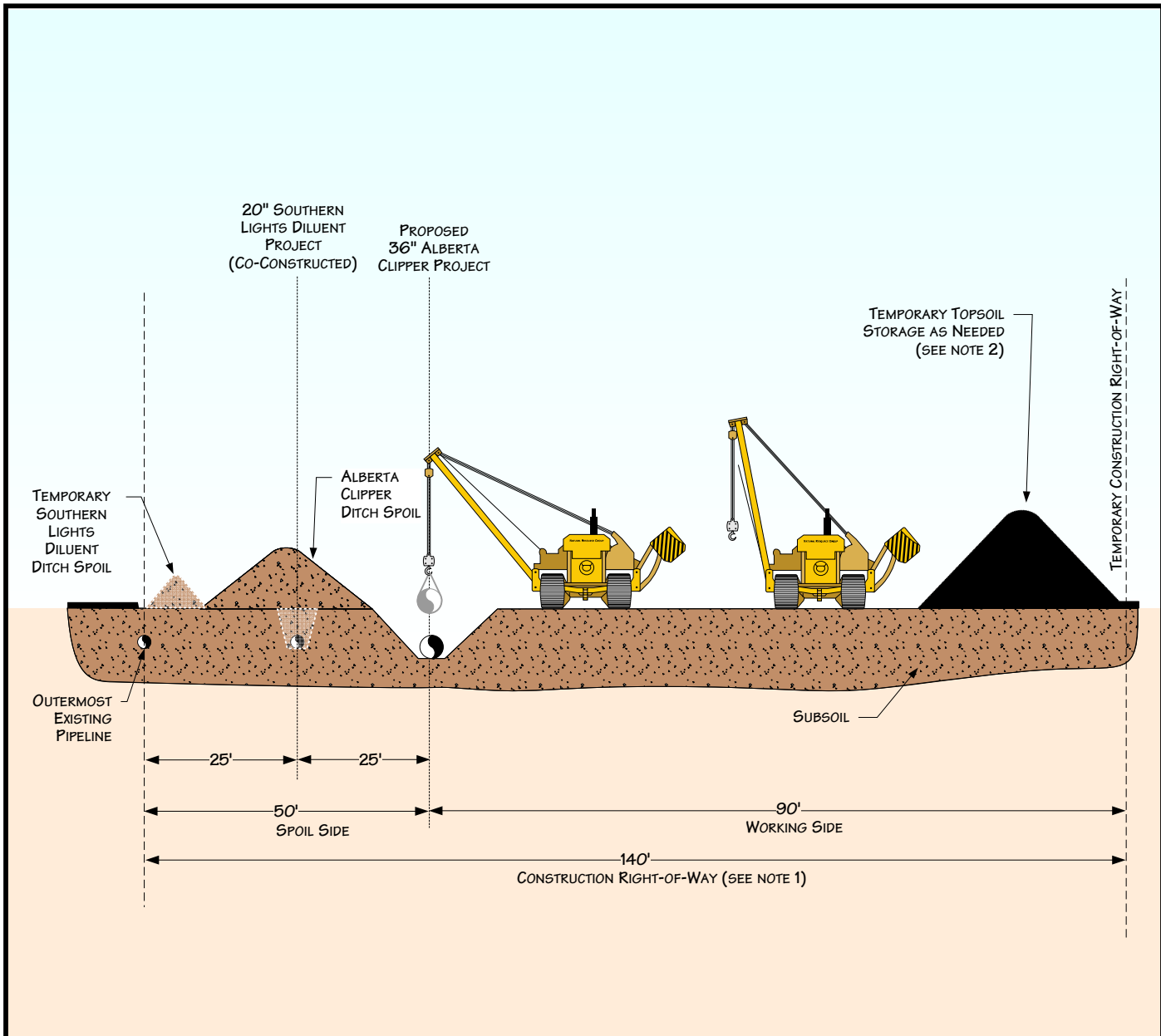
**NOTES:**

1. CONSTRUCTION RIGHT-OF-WAY WILL TYPICALLY BE 140' WIDE. THE SPOIL SIDE WILL BE APPROXIMATELY 50' WIDE AND GENERALLY WITHIN THE EXISTING MAINTAINED RIGHT-OF-WAY. THE WORKING SIDE WILL BE 90' WIDE.
2. THIS DRAWING REFLECTS "FULL RIGHT-OF-WAY" TOPSOIL STRIPPING PROCEDURE. STOCKPILE TOPSOIL SEPARATELY FROM DITCH SPOIL AS SHOWN OR IN OTHER CONFIGURATIONS APPROVED BY THE COMPANY.
3. THE OFFSET FROM NORTHERNMOST OR SOUTHERNMOST EXISTING PIPELINE, WHERE APPLICABLE, WILL BE 25' FOR MOST LOCATIONS BUT MAY BE INCREASED OR DECREASED DEPENDING ON THE SITE SPECIFIC CONSTRUCTION REQUIREMENTS.



**Figure 3A**  
**Environmental Mitigation Plan**  
 Typical Topsoil Segregation  
 Full Right-of-Way  
 (Neché, ND to Clearbrook, MN)

DATE: 7/9/2001	
REVISED: 1/16/09	
SCALE: NTS	
DRAWN BY: KMKENDALL	
K:\335\ALBERTA\2006-135\WIDNR_FIGURES\WI_ROW_ENV_MIT_PLAN_MN.VSD	



PROFILE

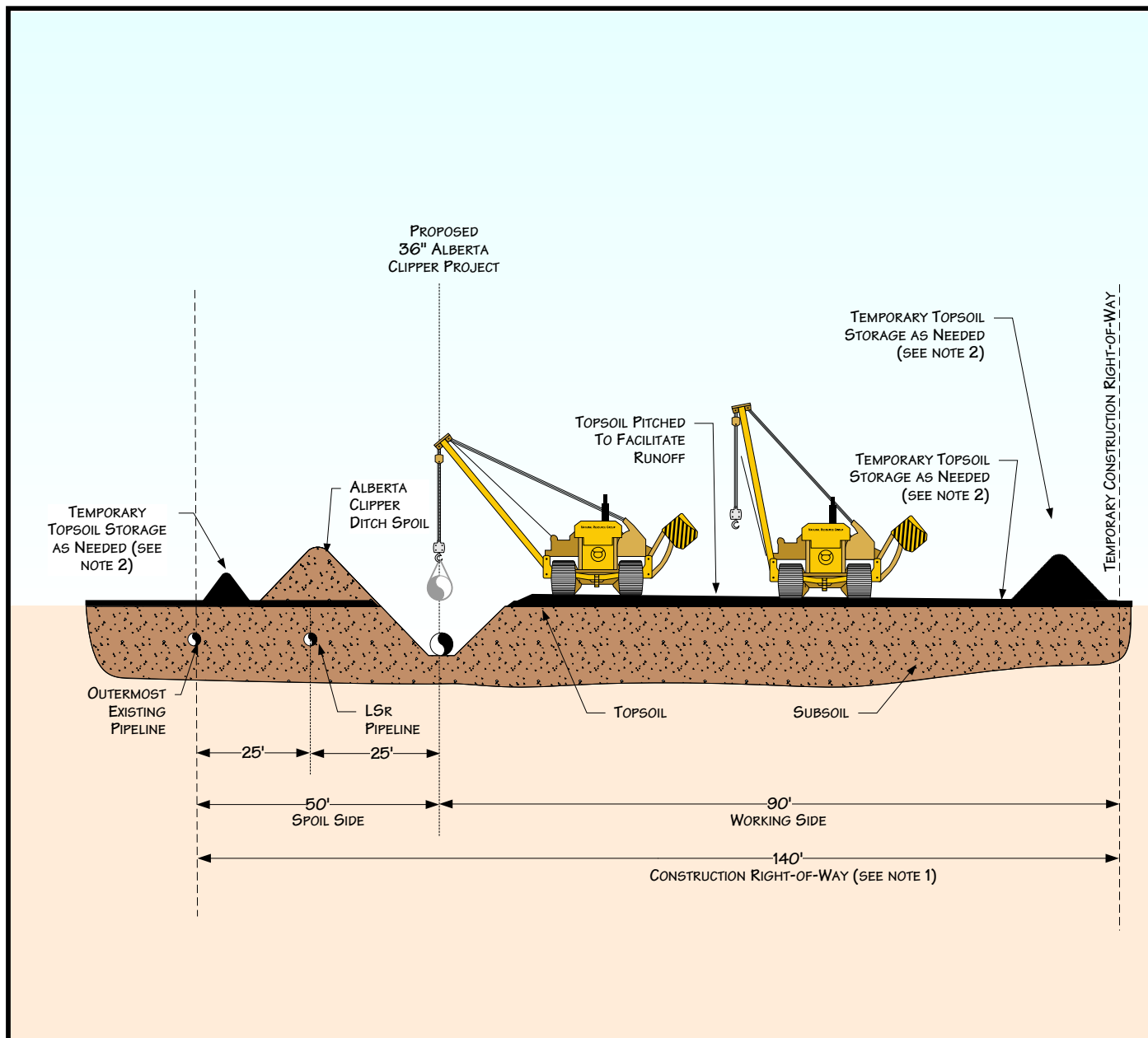
NOTES:

1. CONSTRUCTION RIGHT-OF-WAY WILL TYPICALLY BE 140' WIDE. THE SPOIL SIDE WILL BE APPROXIMATELY 50' WIDE AND GENERALLY WITHIN THE EXISTING MAINTAINED RIGHT-OF-WAY. THE WORKING SIDE WILL BE 90' WIDE.
2. THIS DRAWING REFLECTS "FULL RIGHT-OF-WAY" TOPSOIL STRIPPING PROCEDURE. STOCKPILE TOPSOIL SEPARATELY FROM DITCH SPOIL AS SHOWN OR IN OTHER CONFIGURATIONS APPROVED BY THE COMPANY.
3. THE OFFSET FROM NORTHERNMOST OR SOUTHERNMOST EXISTING PIPELINE, WHERE APPLICABLE, WILL BE 25' FOR MOST LOCATIONS BUT MAY BE INCREASED OR DECREASED DEPENDING ON THE SITE SPECIFIC CONSTRUCTION REQUIREMENTS.



**Figure 3B**  
**Environmental Mitigation Plan**  
 Typical Topsoil Segregation  
 Full Right-of-Way  
 (Clearbrook, MN to Superior, WI)

DATE: 7/9/2001	
REVISED: 1/16/08	
SCALE: NTS	
DRAWN BY: KMKENDALL	
K:\335\ALBERTA\2006-135\WIDNR_FIGURES\WI_ROW_ENV_MIT_PLAN2.VSD	



**PROFILE**

**NOTES:**

1. CONSTRUCTION RIGHT-OF-WAY WILL TYPICALLY BE 140' WIDE. THE SPOIL SIDE WILL BE APPROXIMATELY 50' WIDE AND GENERALLY WITHIN THE EXISTING MAINTAINED RIGHT-OF-WAY. THE WORKING SIDE WILL BE 90' WIDE.
2. THIS DRAWING REFLECTS "TRENCH LINE ONLY" TOPSOIL STRIPPING PROCEDURE. STOCKPILE TOPSOIL SEPARATELY FROM DITCH SPOIL AS SHOWN OR IN OTHER CONFIGURATIONS APPROVED BY THE COMPANY.
3. THE OFFSET FROM NORTHERNMOST OR SOUTHERNMOST EXISTING PIPELINE, WHERE APPLICABLE, WILL BE 25' FOR MOST LOCATIONS BUT MAY BE INCREASED OR DECREASED DEPENDING ON THE SITE SPECIFIC CONSTRUCTION REQUIREMENTS.

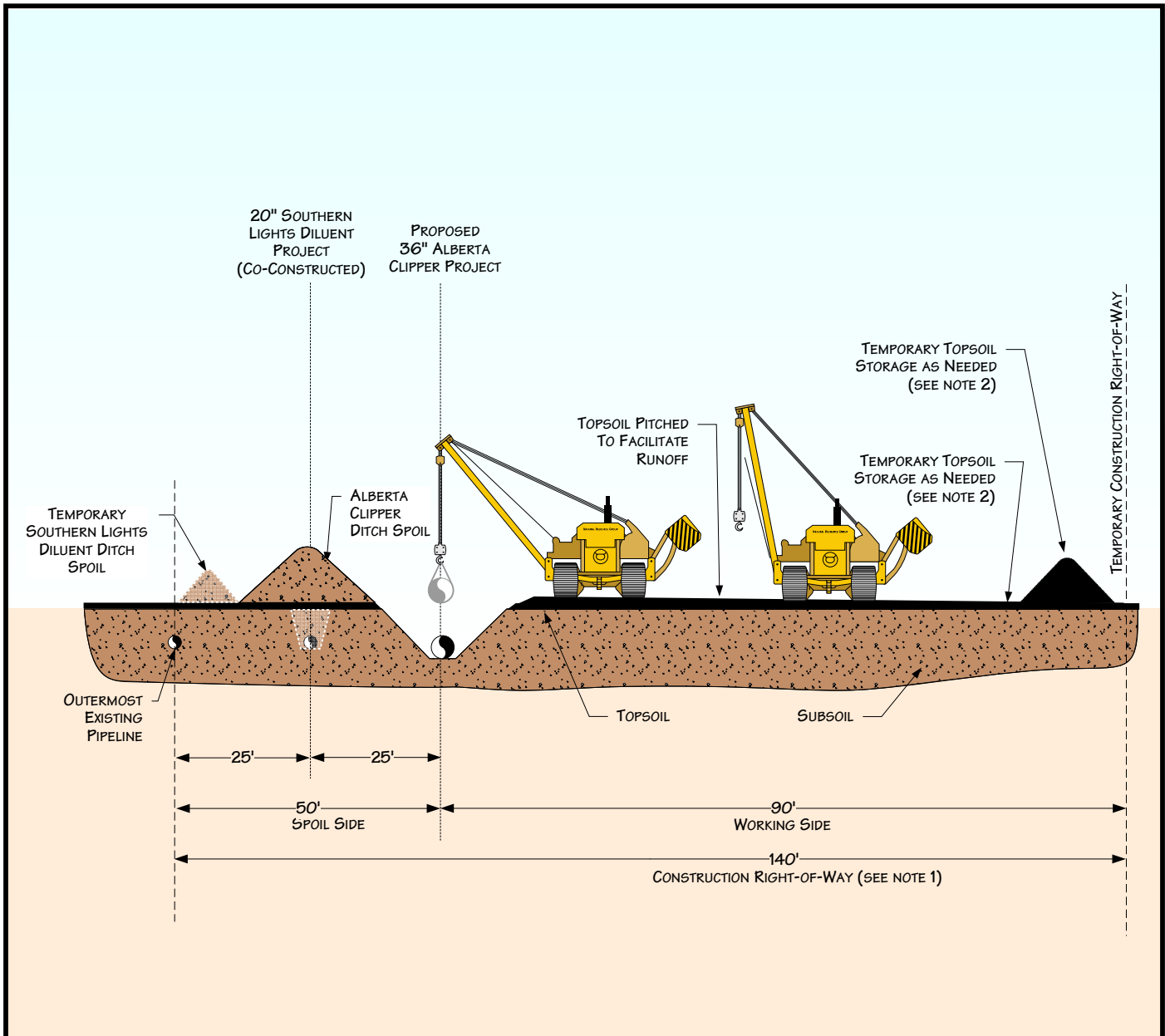


**Figure 4A**  
**Environmental Mitigation Plan**  
 Typical Topsoil Segregation  
 Trench Line Only  
 (Neché, ND to Clearbrook, MN)

DATE: 7/9/2001  
 REVISED: 1/16/08  
 SCALE: NTS  
 DRAWN BY: KMKENDALL



K:\335\MN\_EMP\FIGURE04A.VSD



**PROFILE**

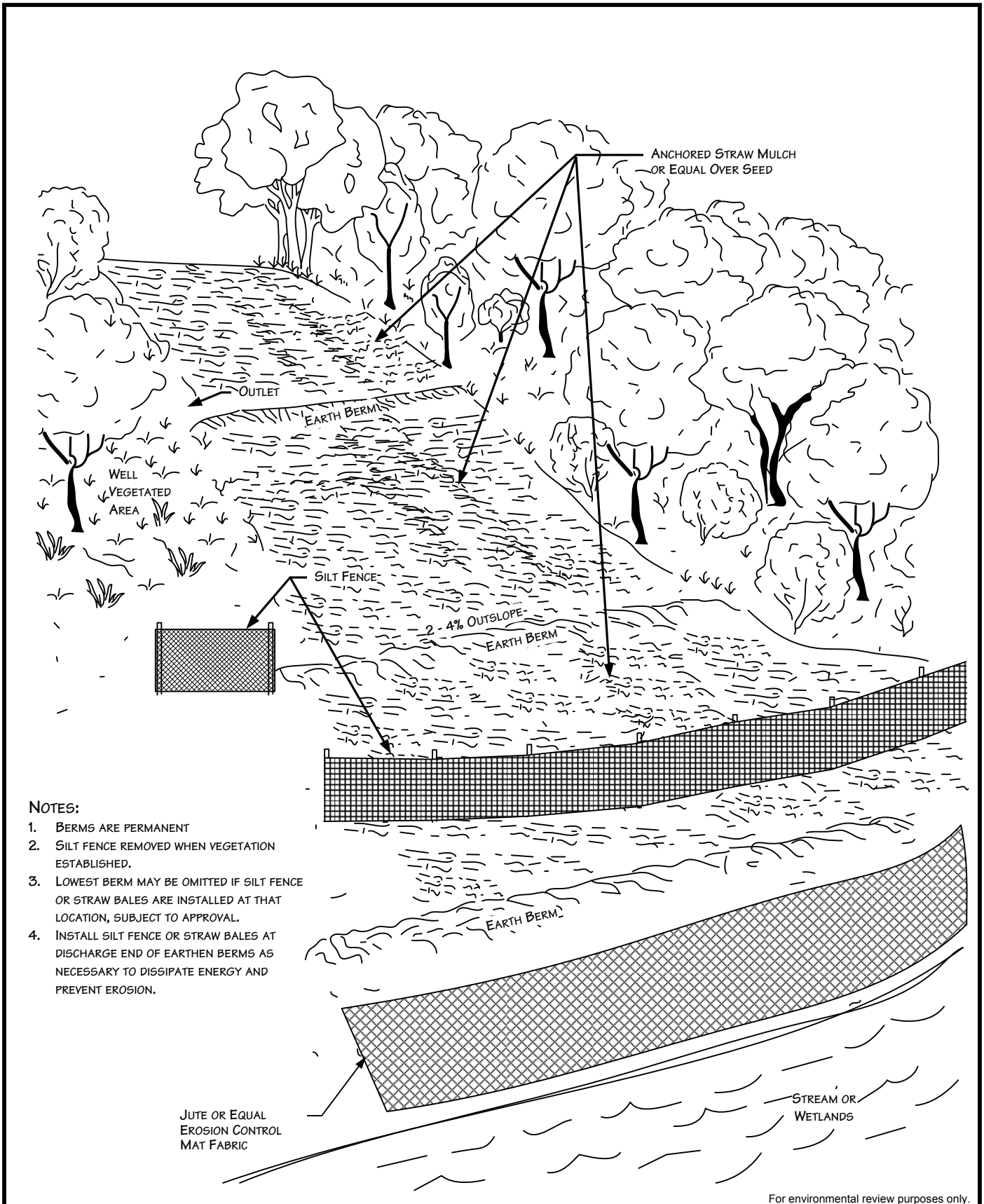
**NOTES:**

1. CONSTRUCTION RIGHT-OF-WAY WILL TYPICALLY BE 140' WIDE. THE SPOIL SIDE WILL BE APPROXIMATELY 50' WIDE AND GENERALLY WITHIN THE EXISTING MAINTAINED RIGHT-OF-WAY. THE WORKING SIDE WILL BE 90' WIDE.
2. THIS DRAWING REFLECTS "TRENCH LINE ONLY" TOPSOIL STRIPPING PROCEDURE. STOCKPILE TOPSOIL SEPARATELY FROM DITCH SPOIL AS SHOWN OR IN OTHER CONFIGURATIONS APPROVED BY THE COMPANY.
3. THE OFFSET FROM NORTHERNMOST OR SOUTHERNMOST EXISTING PIPELINE, WHERE APPLICABLE, WILL BE 25' FOR MOST LOCATIONS BUT MAY BE INCREASED OR DECREASED DEPENDING ON THE SITE SPECIFIC CONSTRUCTION REQUIREMENTS.



**Figure 4B**  
**Environmental Mitigation Plan**  
 Typical Topsoil Segregation  
 Trench Line Only  
 (Clearbrook, MN to Superior, WI)

DATE: 7/9/2001	
REVISED: 1/16/09	
SCALE: NTS	
DRAWN BY: KMKENDALL	
K:\335\MN_EMP\FIGURE04B.VSD	



**NOTES:**

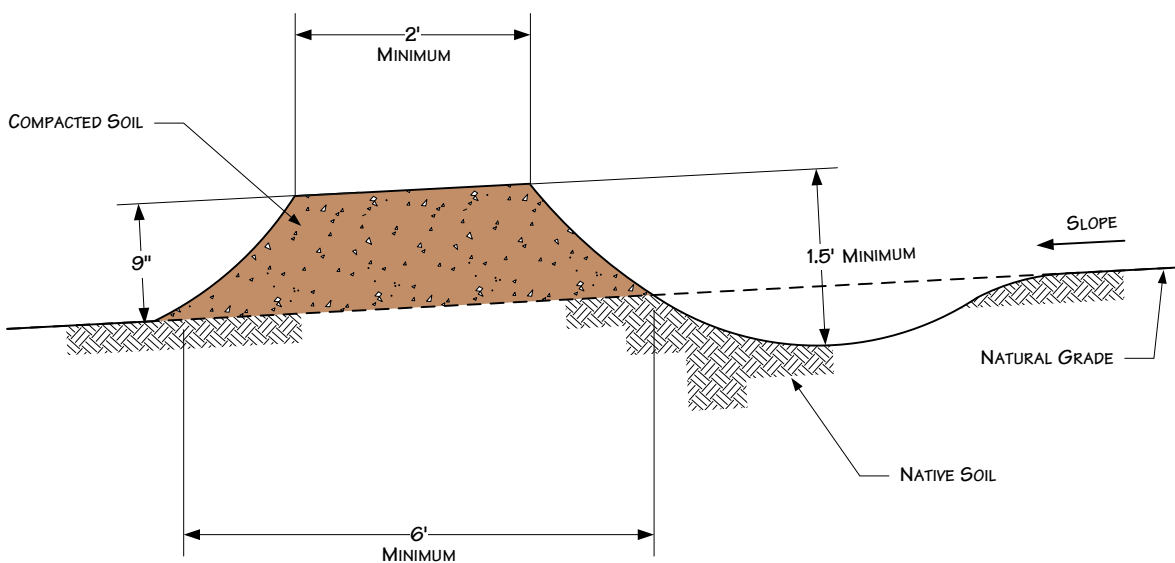
1. BERMS ARE PERMANENT
2. SILT FENCE REMOVED WHEN VEGETATION ESTABLISHED.
3. LOWEST BERM MAY BE OMITTED IF SILT FENCE OR STRAW BALES ARE INSTALLED AT THAT LOCATION, SUBJECT TO APPROVAL.
4. INSTALL SILT FENCE OR STRAW BALES AT DISCHARGE END OF EARTHEN BERMS AS NECESSARY TO DISSIPATE ENERGY AND PREVENT EROSION.

For environmental review purposes only.



**Figure 5**  
**Environmental Mitigation Plan**  
 Typical Temporary or Permanent Berms  
 Perspective View

DATE: 11/14/2000	
REVISED: 1/16/2009	
SCALE: NTS	
DRAWN BY: KMKENDALL	
K:\335\ALBERTA\2006-135\400\1.5.VSD	



**NOTES**

1. BERMS SHALL BE CONSTRUCTED WITH 2 TO 4 PERCENT OUTSLOPE.
2. BERMS SHALL BE OUTLETED TO WELL VEGETATED STABLE AREAS, SILT FENCES, STRAW BALES OR ROCK APRONS.
3. BERMS SHALL BE SPACED AS DESCRIBED IN CONSTRUCTION SPECIFICATIONS.
4. ADDITIONAL INFORMATION INCLUDED ON OTHER DRAWINGS.

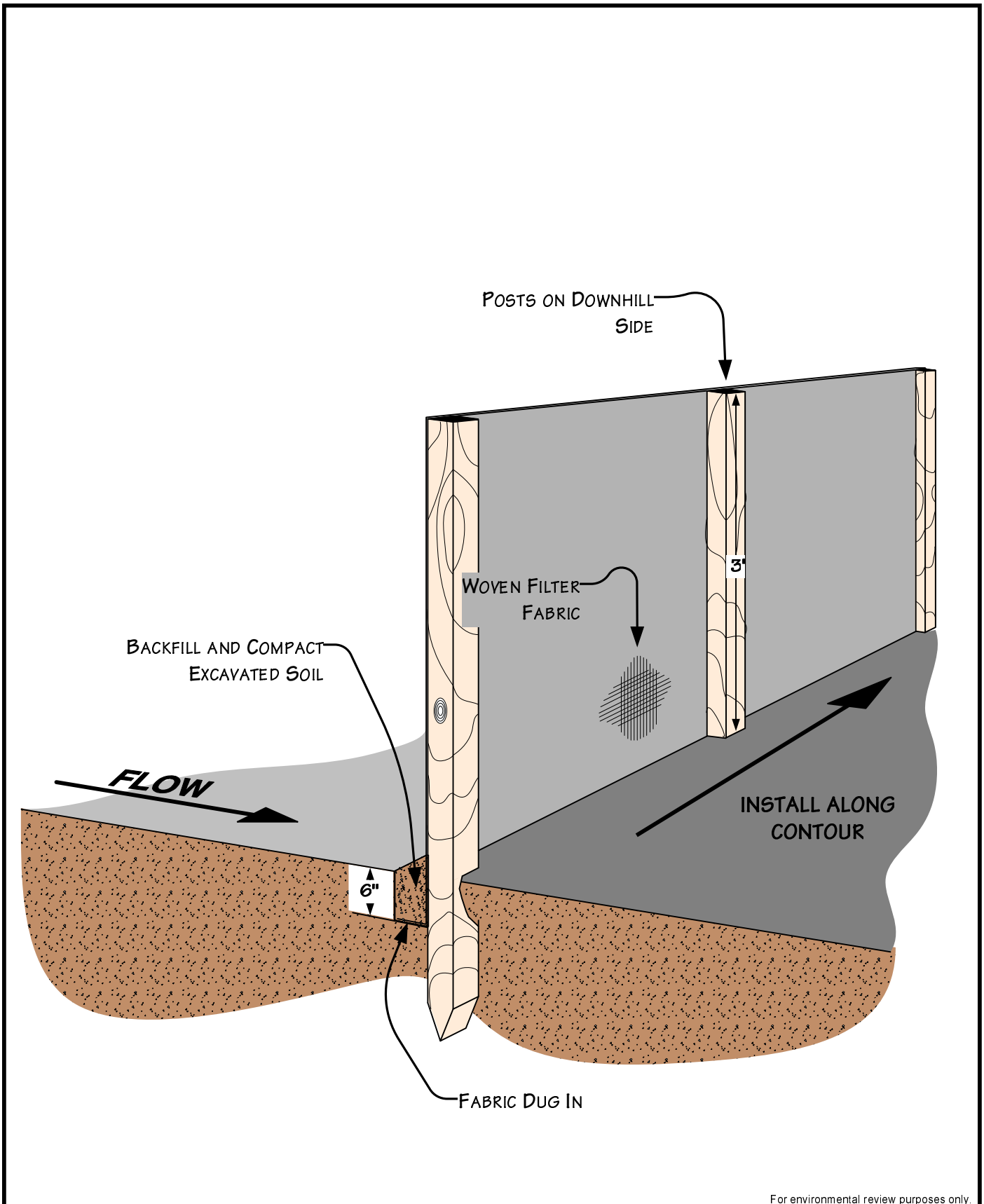
For environmental review purposes only.



**Figure 6**  
**Environmental Mitigation Plan**  
 Typical Temporary or Permanent Berms  
 Elevation View

DATE: 5/25/2001	
REVISED: 1/16/2009	
SCALE: NTS	
DRAWN BY: KMKENDALL	
K:\335\ALBERTA\2006-135\400\1.6.VSD	



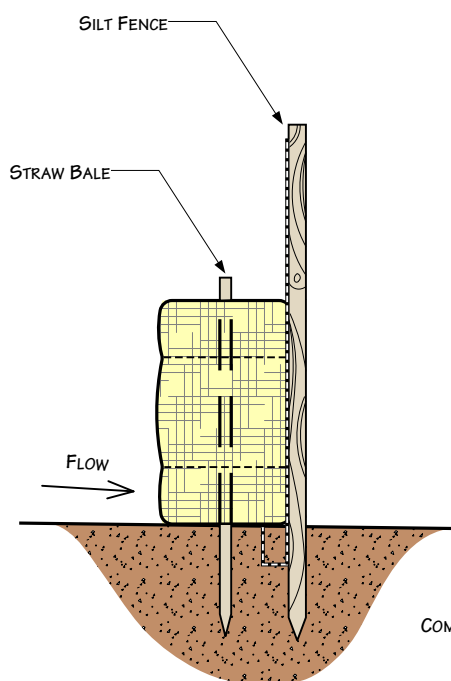
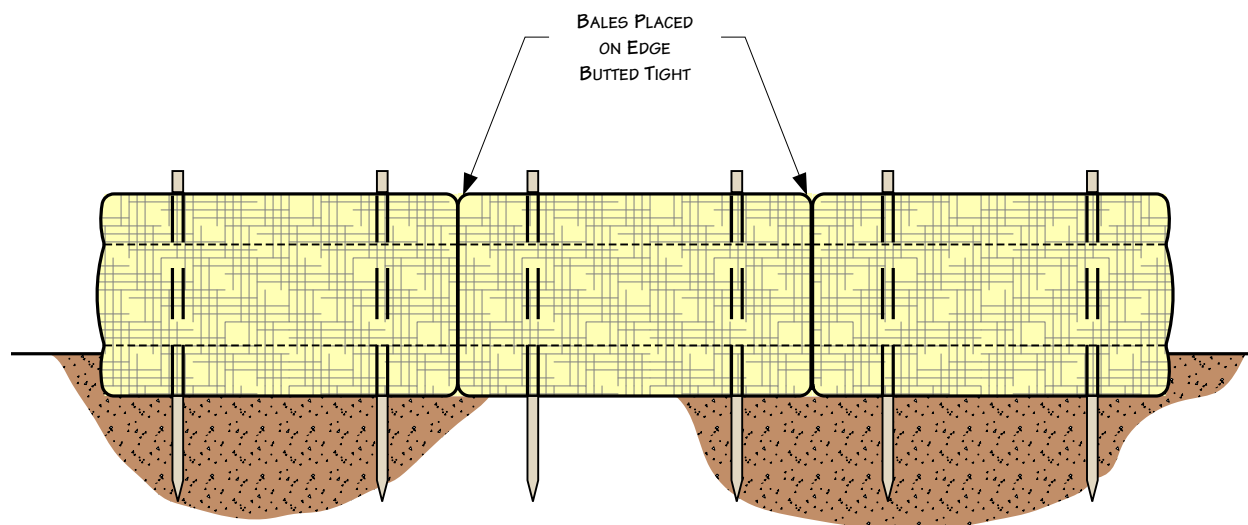


For environmental review purposes only.

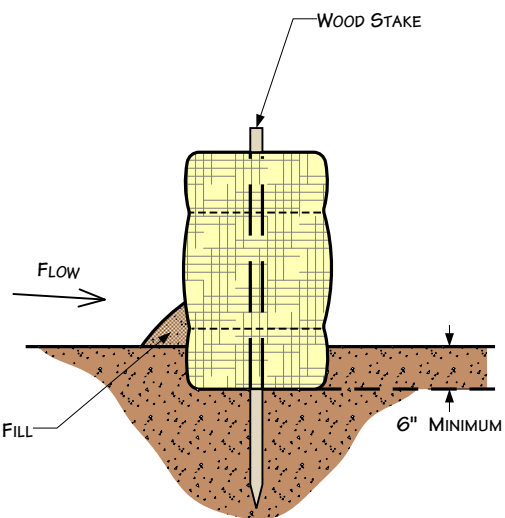


**Figure 7**  
**Environmental Mitigation Plan**  
 Typical Silt Fence Installation

DATE: 5/25/2001	
REVISED: 10/24/08	
SCALE: NTS	
DRAWN BY: KMKENDALL	
K:\335\ALBERTA\2006-135\400\1.7.VSD	



STRAW BALES & SILT FENCE



STRAW BALES ONLY

For environmental review purposes only.



**Figure 8**  
**Environmental Mitigation Plan**  
**Typical Straw Bale Installation**

DATE: 5/25/01

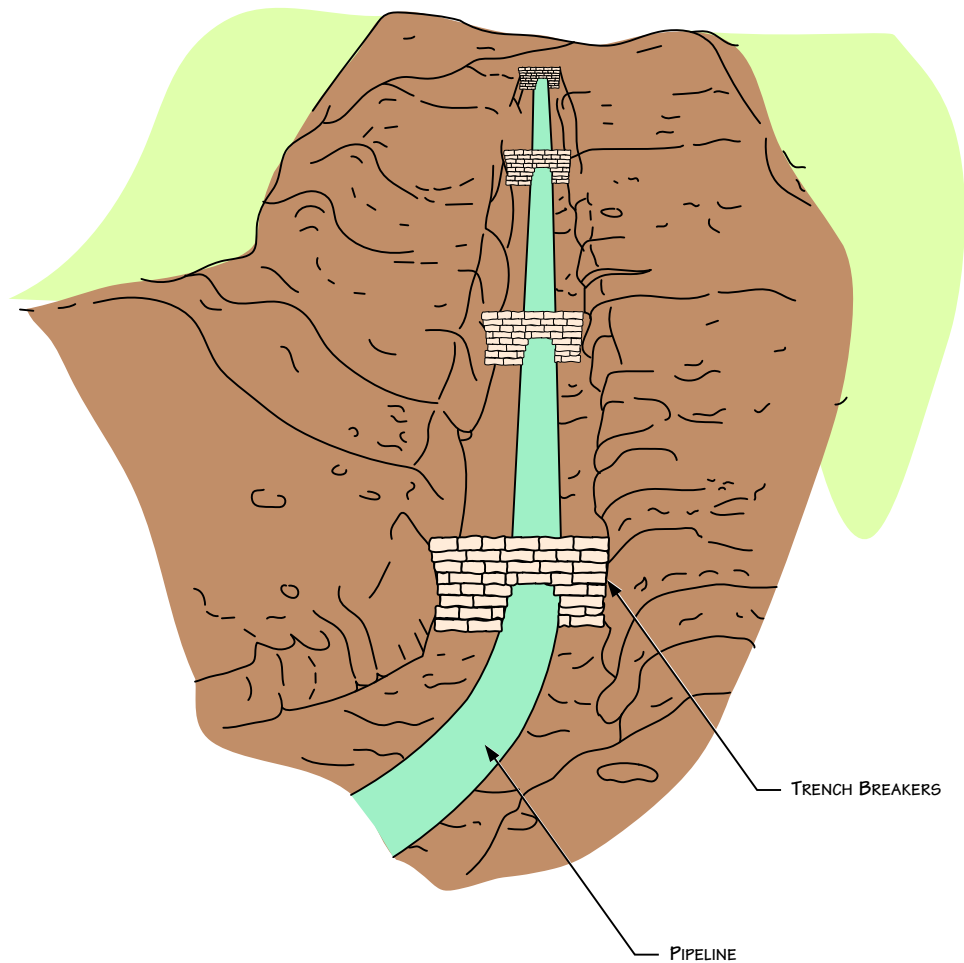
REVISED: 1/19/09

SCALE: Not to Scale

DRAWN BY: KMKENDALL

K:\335\ALBERTA\2006-135\400\1.8.VSD





NOTES

1. BAGS WILL NOT BE FILLED WITH TOPSOIL.
2. ADDITIONAL INFORMATION INCLUDED ON OTHER DRAWINGS.

For environmental review purposes only.



**Figure 9**  
**Environmental Mitigation Plan**  
 Typical Trench Breakers - Perspective View

DATE: 5/25/2001

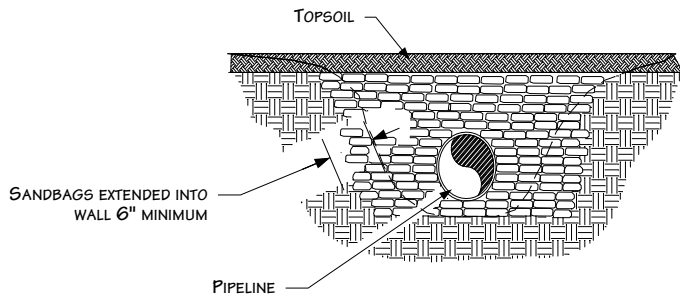
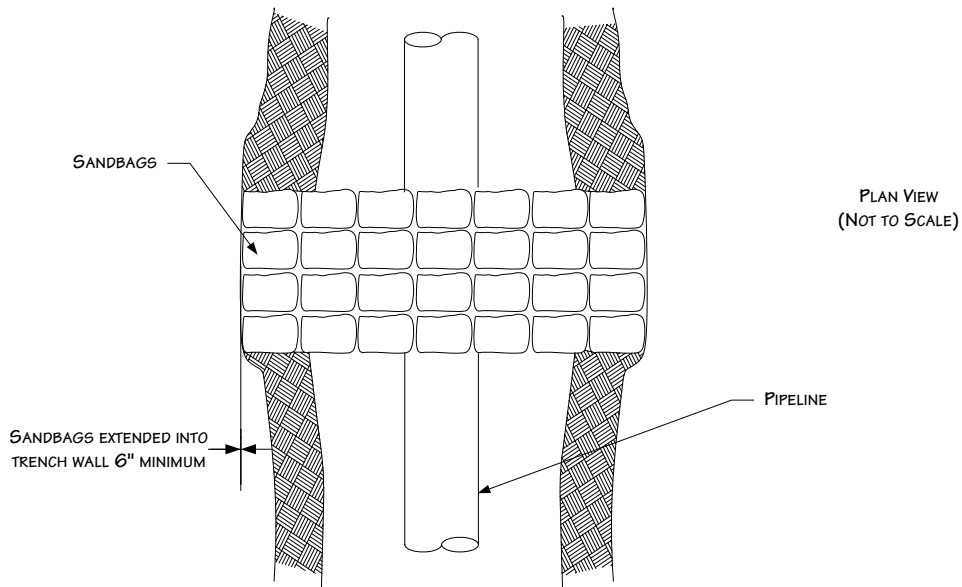
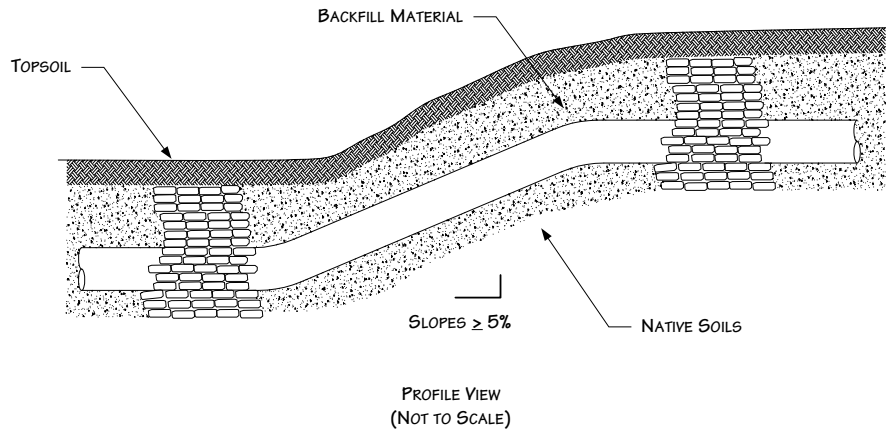
REVISED: 12/8/08

SCALE: NTS

DRAWN BY: KMKENDALL

K:\335\ALBERTA\2006-135\400\1.9.VSD





NOTES

1. BAGS WILL NOT BE FILLED WITH TOPSOIL
2. ADDITIONAL INFORMATION INCLUDED ON OTHER DRAWINGS

For environmental review purposes only.



**Figure 10**  
**Environmental Mitigation Plan**  
 Typical Trench Breakers – Plan & Profile View

DATE: 11/15/2000

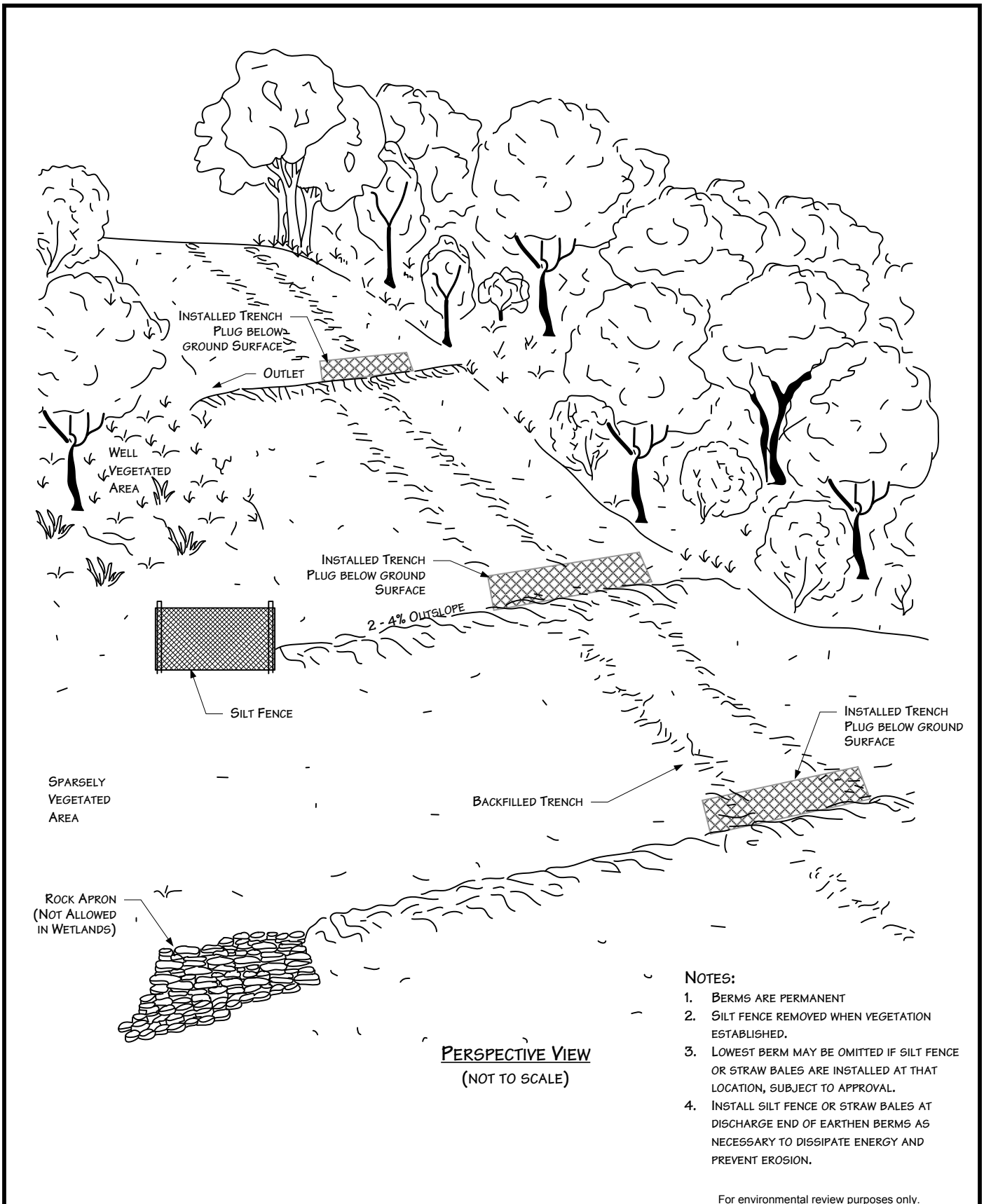
REVISED: 10/24/08

SCALE: NTS

DRAWN BY: KMKENDALL

K:\335\ALBERTA\2006-135\400\1.10.VSD





**NOTES:**

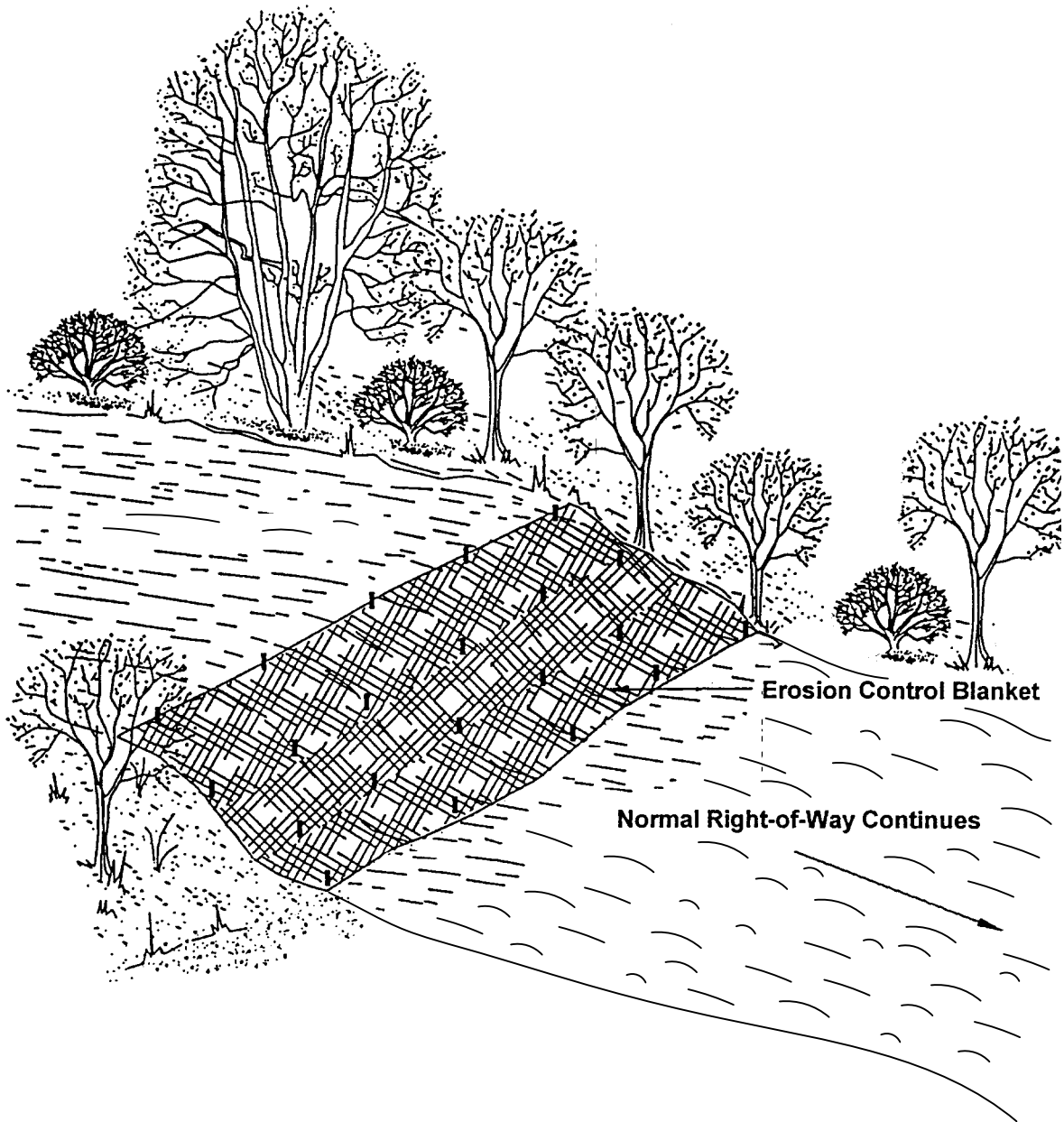
1. BERMS ARE PERMANENT
2. SILT FENCE REMOVED WHEN VEGETATION ESTABLISHED.
3. LOWEST BERM MAY BE OMITTED IF SILT FENCE OR STRAW BALES ARE INSTALLED AT THAT LOCATION, SUBJECT TO APPROVAL.
4. INSTALL SILT FENCE OR STRAW BALES AT DISCHARGE END OF EARTHEN BERMS AS NECESSARY TO DISSIPATE ENERGY AND PREVENT EROSION.

For environmental review purposes only.



**Figure 11**  
**Environmental Mitigation Plan**  
 Permanent Slope Breakers - Perspective View

DATE: 5/25/2001	
REVISED: 1/16/2009	
SCALE: NTS	
DRAWN BY: KMKENDALL	
K:\335\ALBERTA\2006-135\400\7.1.VSD	



**NOTES**

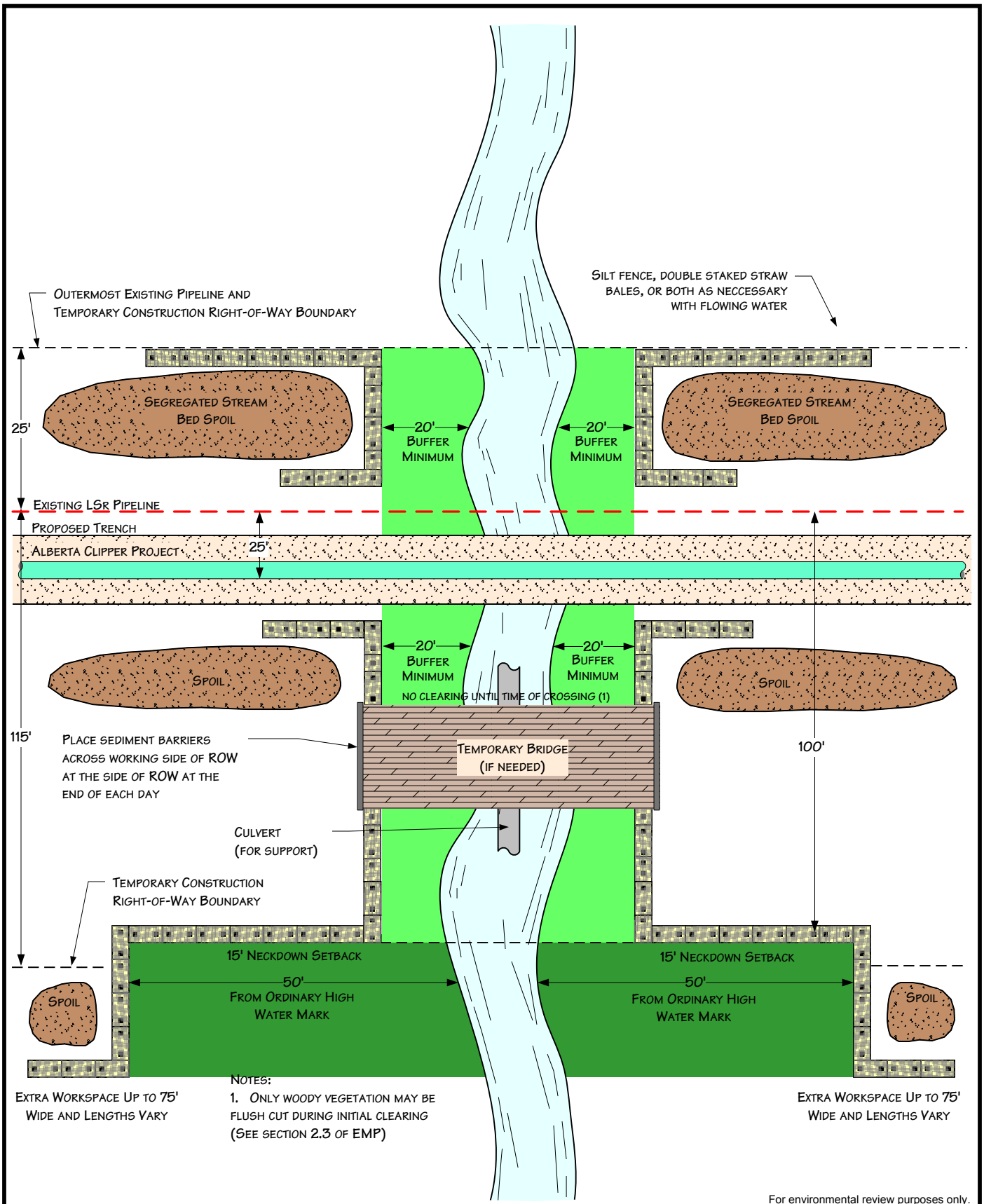
1. INSTALL EROSION CONTROL BLANKET AS PER MANUFACTURER'S SPECIFICATIONS.
2. ADDITIONAL INFORMATION INCLUDED ON OTHER DRAWINGS.

For environmental review purposes only.



**Figure 12**  
**Environmental Mitigation Plan**  
 Erosion Control Blanket - Steep Slopes ( $\geq 30\%$ )

DATE: 11/15/2000	
REVISED: 10/24/08	
SCALE: NTS	
DRAWN BY: KMKENDALL	
K:\335\ALBERTA\2006-135\400\7.2.VSD	



For environmental review purposes only.



**Figure 13A**  
**Environmental Mitigation Plan**  
 Typical Waterbody Crossing  
 Open Cut – Wet Trench Method  
 (Neché, ND to Clearbrook, MN)

DATE: 11/29/2005

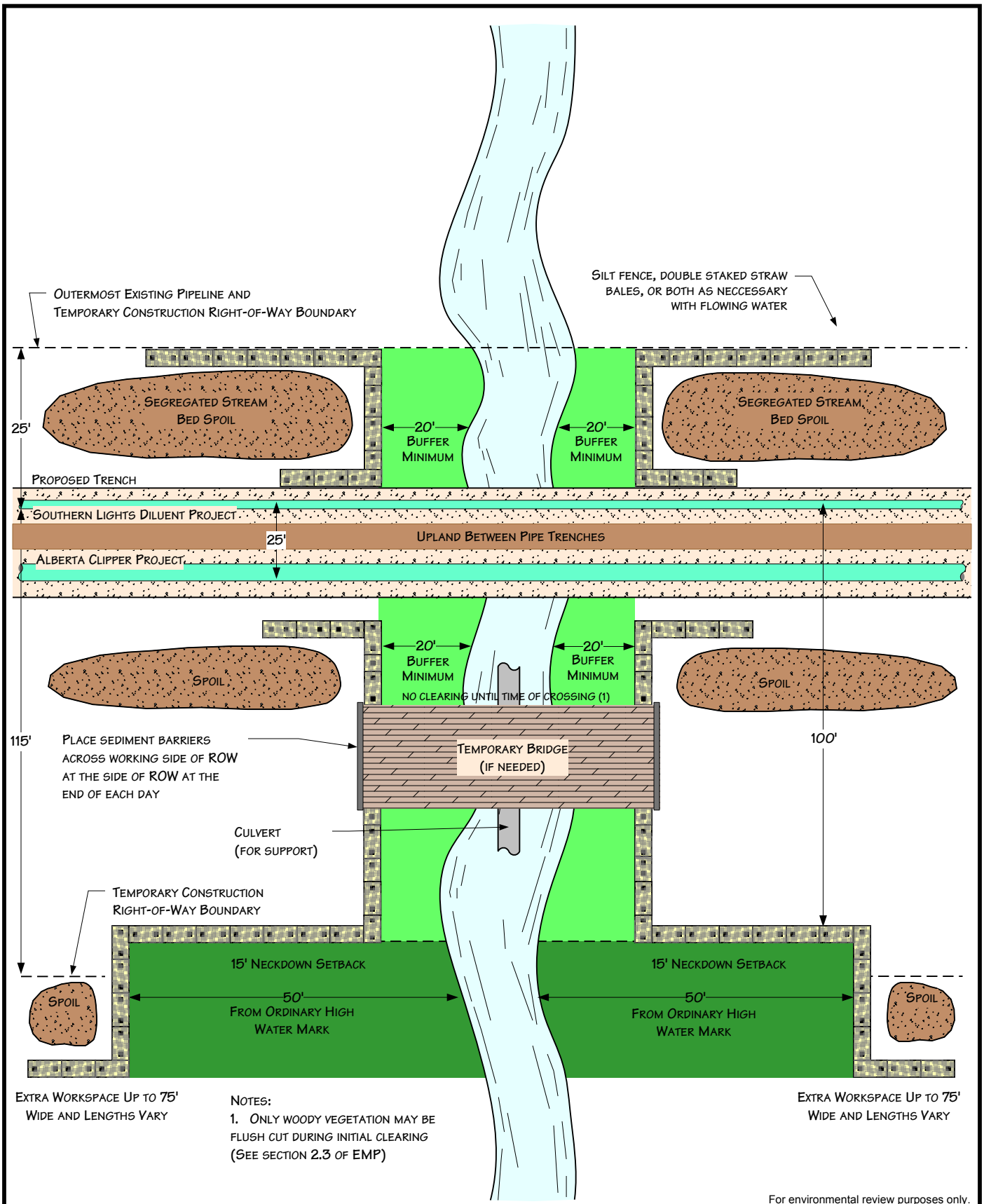
REVISED: 1/19/09

SCALE: NTS

DRAWN BY: KJA

K:\335\MN\_EMP\FIGURE13A.VSD





For environmental review purposes only.

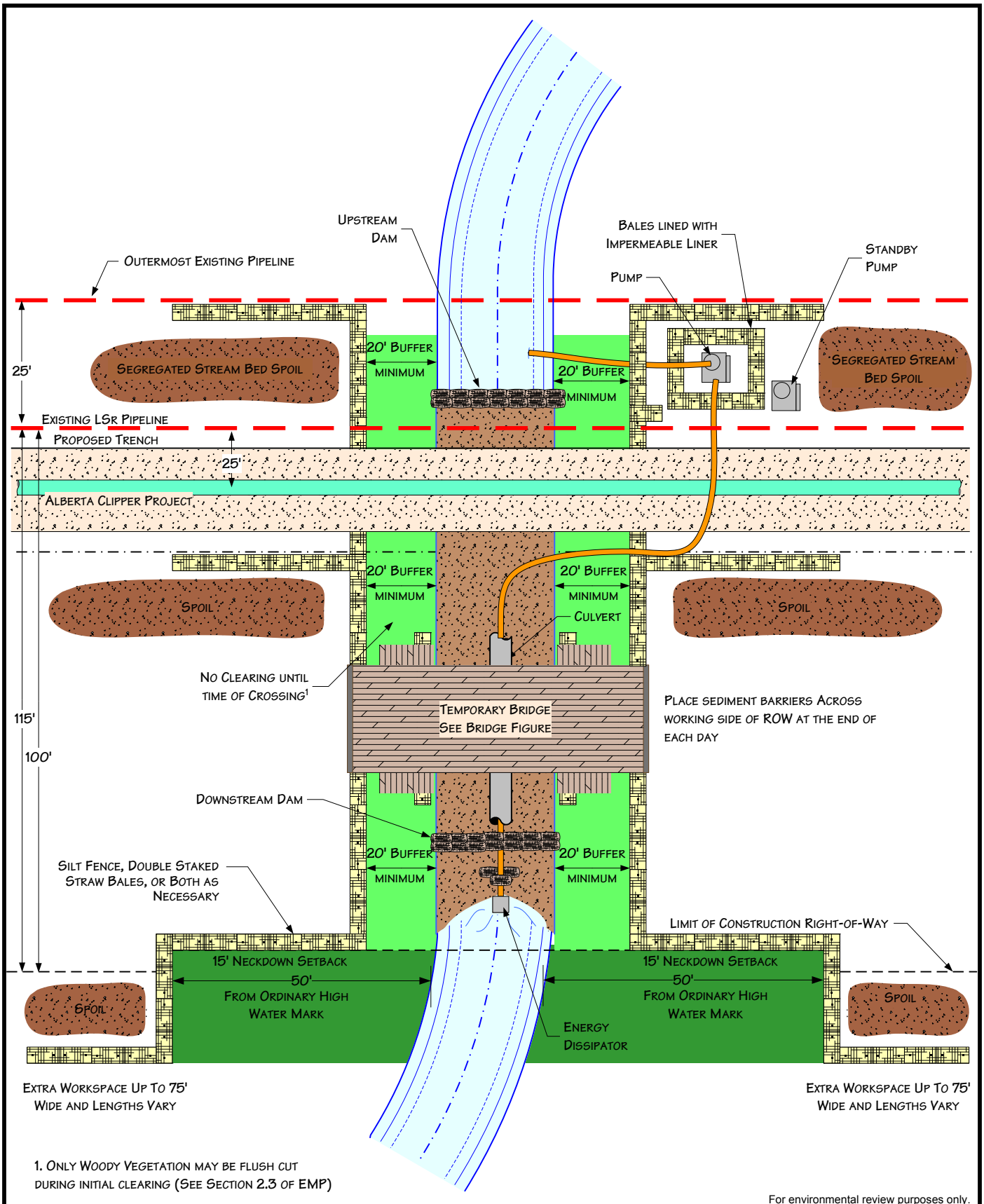


**Figure 13B**  
**Environmental Mitigation Plan**  
 Typical Waterbody Crossing  
 Open Cut – Wet Trench Method  
 (Clearbrook, MN to Superior, WI)

DATE: 11/29/2005  
 REVISED: 1/19/09  
 SCALE: NTS  
 DRAWN BY: KJA  
 K:\335\MN\_EMP\FIGURE13B.VSD

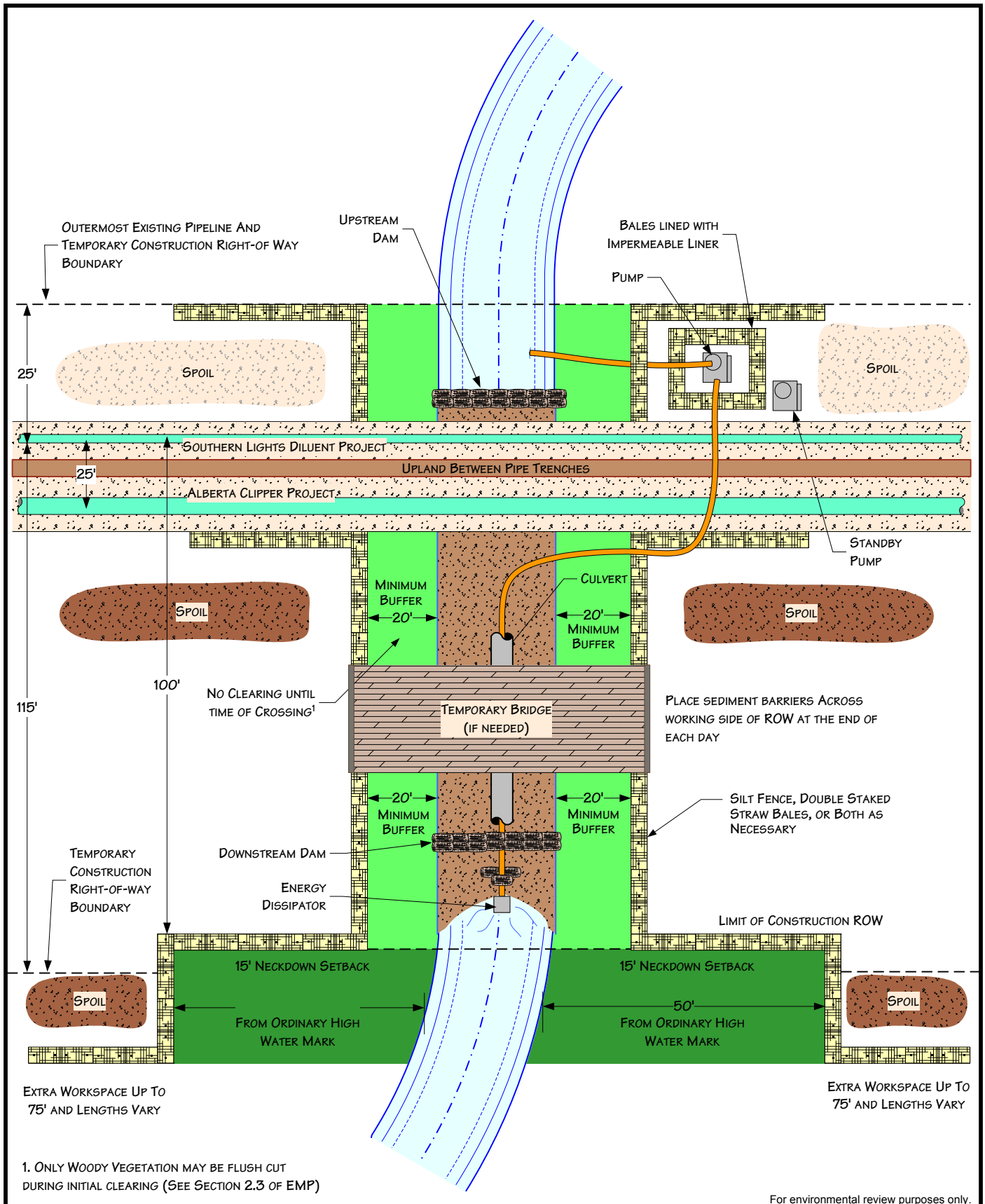






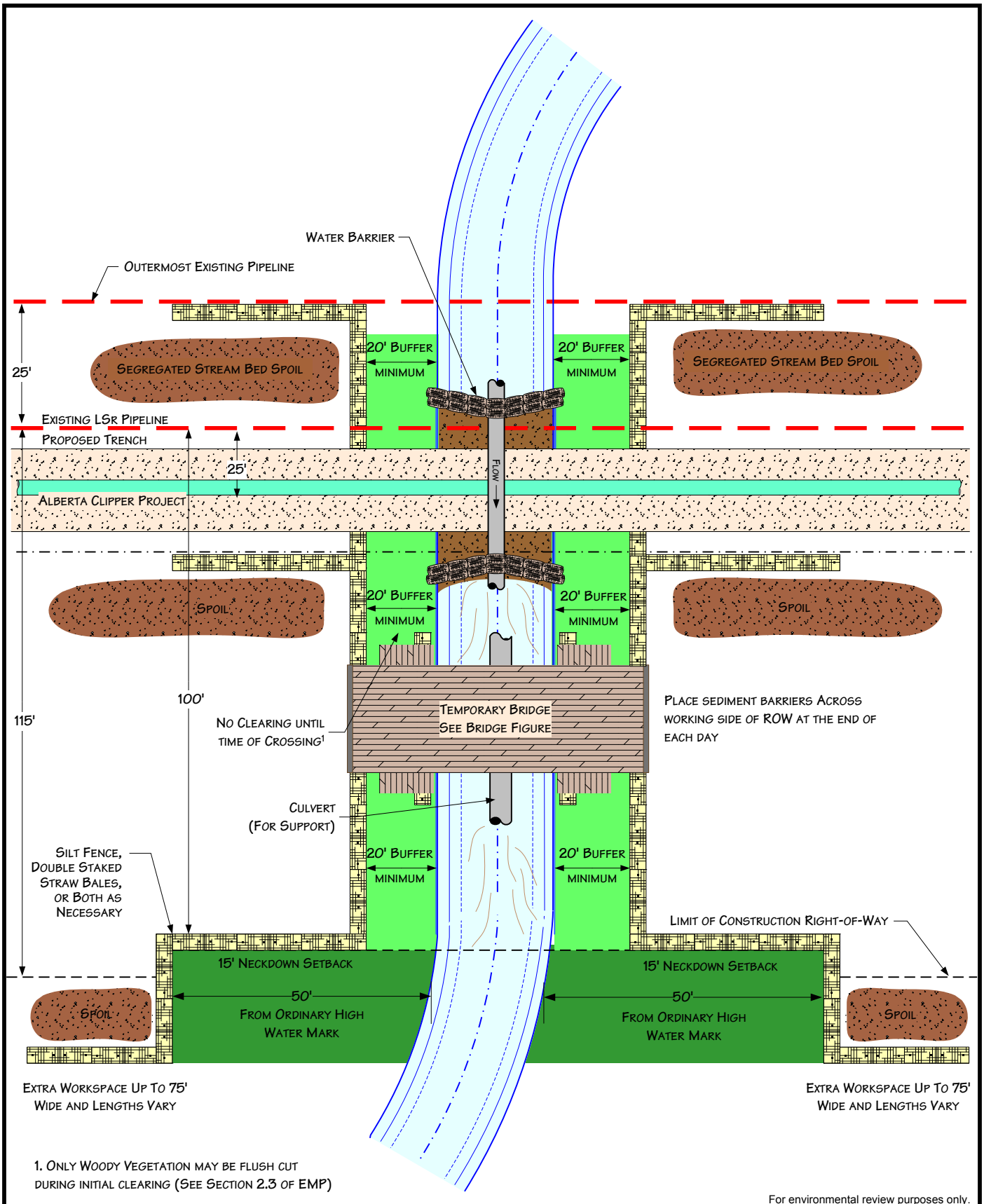
**Figure 14A**  
**Environmental Mitigation Plan**  
 Typical Waterbody Crossing  
 Dam and Pump Method  
 (Neché, ND to Clearbrook, MN)

DATE: 11/29/2005	
REVISED: 10/24/08	
SCALE: NTS	
DRAWN BY: KJA	
K:\335\MN_EMP\FIGURE14A.VSD	



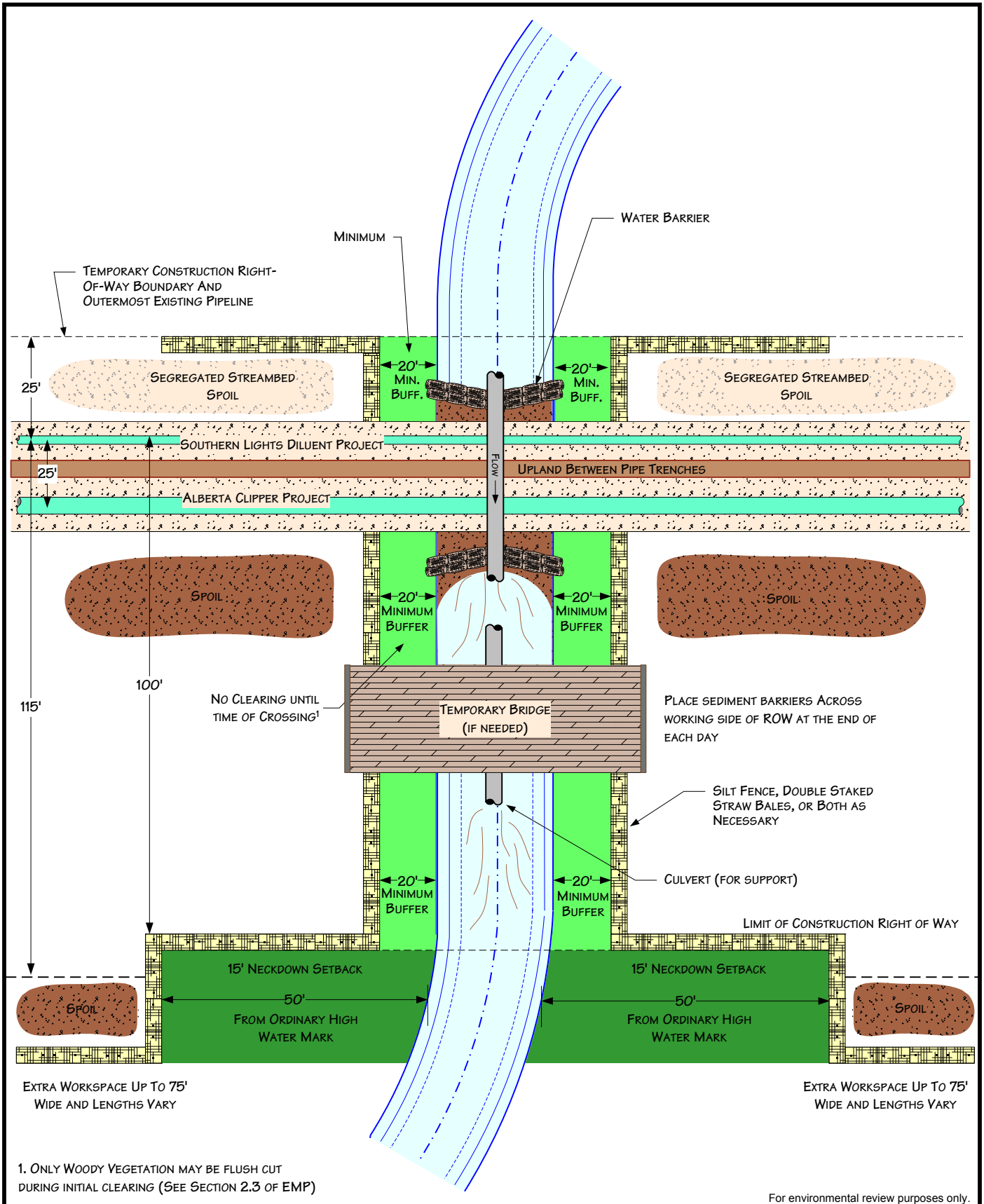
**Figure 14B**  
**Environmental Mitigation Plan**  
 Typical Waterbody Crossing  
 Dam and Pump Method  
 (Clearbrook, MN to Superior, WI)

DATE: 11/29/2005	
REVISED: 1/20/09	
SCALE: NTS	
DRAWN BY: KJA	
K:\335\MN_EMP\FIGURE_14B.VSD	



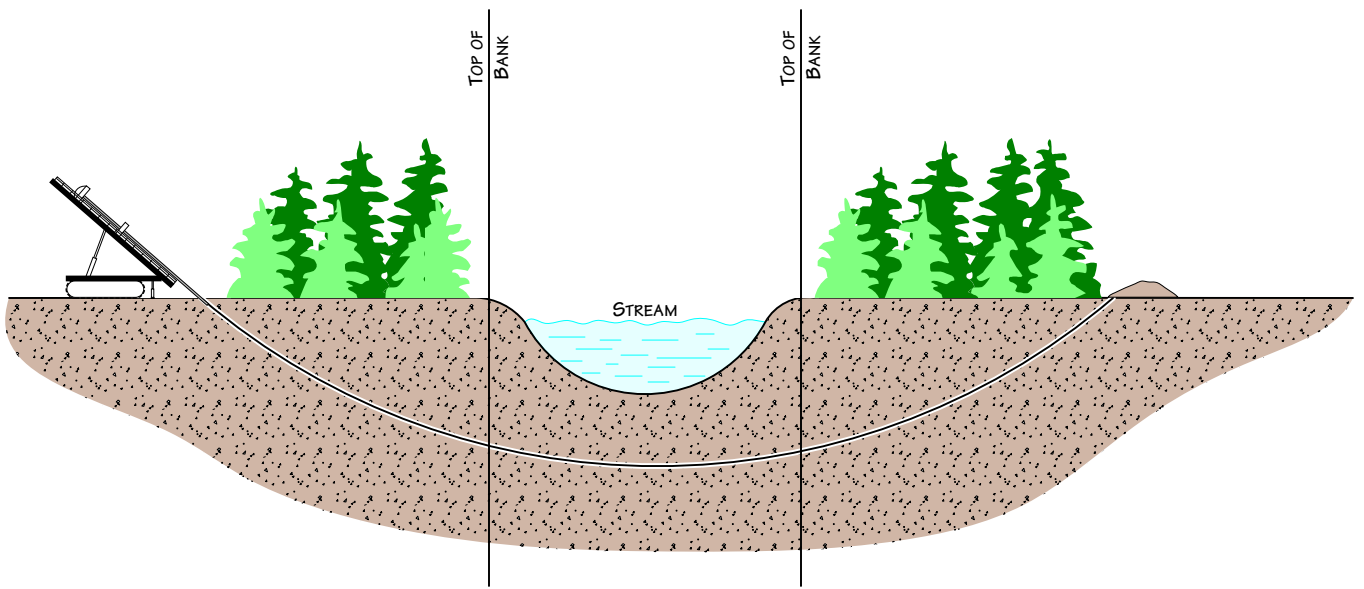
**Figure 15A**  
**Environmental Mitigation Plan**  
 Typical Waterbody Crossing  
 Flume Method  
 (Neché, ND to Clearbrook, MN)

DATE: 11/29/2005	
REVISED: 1/20/09	
SCALE: NTS	
DRAWN BY: KJA	
K:\335\MN_EMP\FIGURE15A.VSD	



**Figure 15B**  
**Environmental Mitigation Plan**  
 Typical Waterbody Crossing  
 Flume Method  
 (Clearbrook, MN to Superior, WI)

DATE: 11/29/2005	
REVISED: 10/24/08	
SCALE: NTS	
DRAWN BY: KJA	
K:\335\MN_EMP\FIGURE15B.VSD	



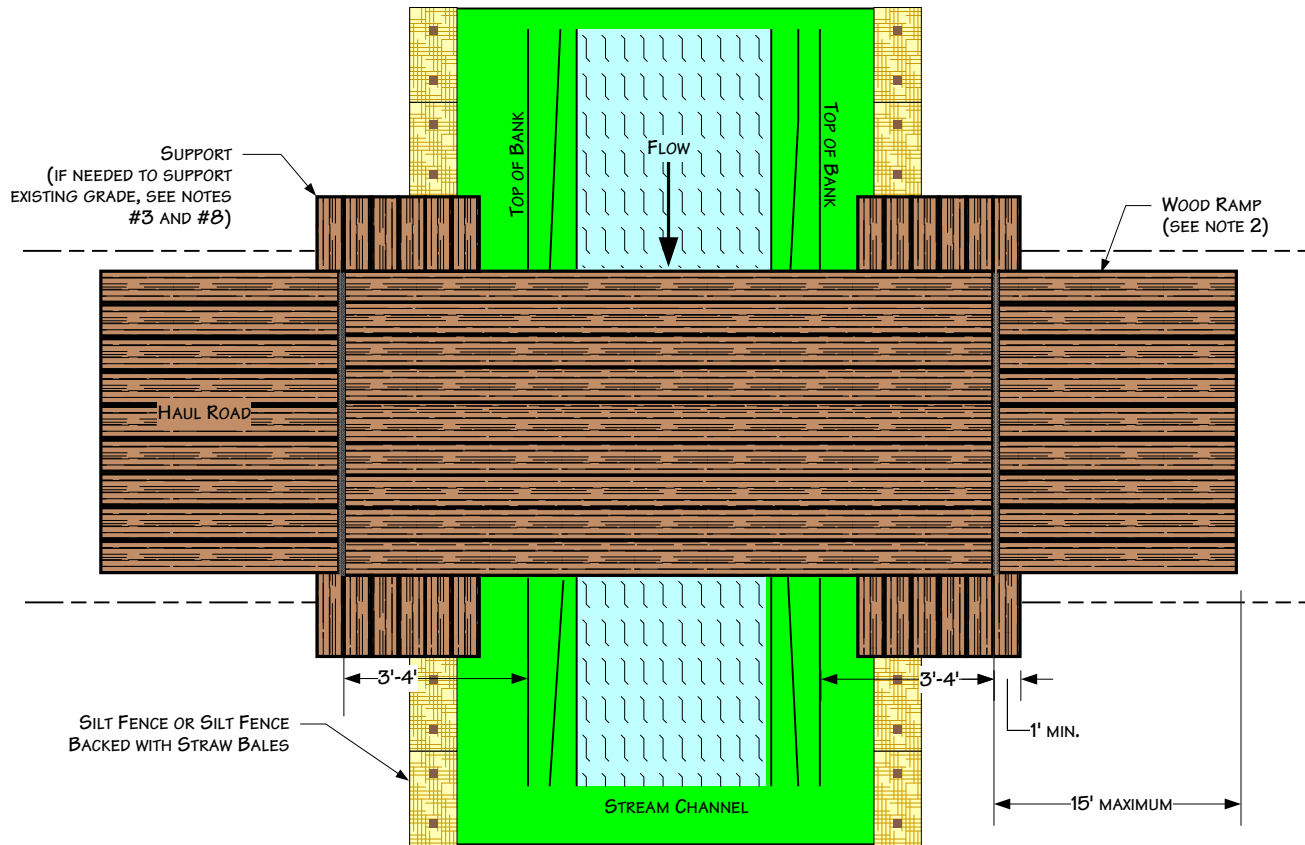
For environmental review purposes only.



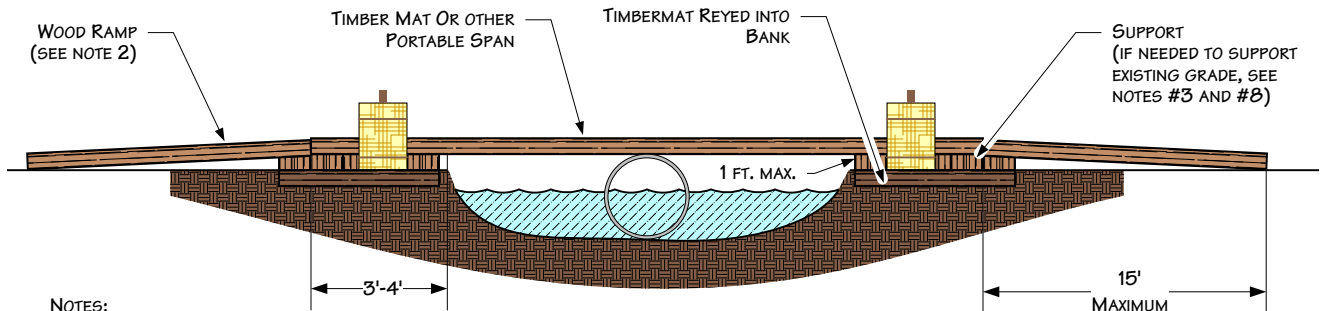
**Figure 16**  
**Environmental Mitigation Plan**  
 Typical Waterbody Crossing  
 Directional Drill Method

DATE: 7/14/2000	
REVISED: 10/24/08	
SCALE: NTS	
DRAWN BY: KMKENDALL	
K:\335\ALBERTA\2006-135\400\2.4.VSD	

## Plan View



## Profile View



### NOTES:

1. INSPECT BRIDGE OPENING PERIODICALLY AND FOLLOWING RAINFALLS OF OVER  $\frac{1}{2}$ ". REMOVE ANY DEBRIS RESTRICTING FLOW AND DEPOSIT IT AT AN UPLAND SITE OUTSIDE OF FLOODPLAIN.
2. IF PHYSICAL CIRCUMSTANCES PROHIBIT WOOD OR METAL RAMPS, EARTHEN RAMPS MAY BE USED AS APPROVED.
3. INSPECT BRIDGE ELEVATION SO BRIDGE REMAINS SUPPORTED ABOVE HIGH BANK AND DOES NOT SINK INTO BANK.
4. THE CULVERT SUPPORT MUST BE ANCHORED TO THE STREAM BOTTOM AND MAY NOT BE SUPPORTED WITH FILL.
5. EARTHEN RAMP CANNOT BE TALLER THAN 1' AND CANNOT EXTEND FOR MORE THAN 15' ON EITHER SIDE OF THE CROSSING.
6. THE BRIDGE MUST SPAN FROM TOP OF BANK TO TOP OF BANK.
7. THE BRIDGE MUST BE FIRMLY ANCHORED TO PREVENT IT FROM BEING TRANSPORTED DOWNSTREAM DURING HIGH FLOW.
8. ADDITIONAL SUPPORT MUST BE ADDED ON TOP OF BANK AND UNDER SPAN IF INITIAL SUPPORT STARTS TO SETTLE.
9. EROSION AND SEDIMENTATION CONTROL MEASURES SHALL BE INSPECTED AND MAINTAINED IN ACCORDANCE WITH THE COMPANY'S ENVIRONMENTAL MITIGATION PLAN

For environmental review purposes only.



**Figure 17**  
**Environmental Mitigation Plan**  
 Typical Span Type Bridge  
 With or Without Instream Support

DATE: 3/11/2003

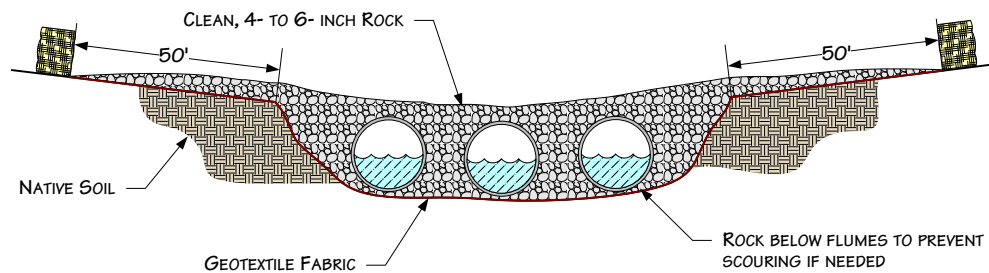
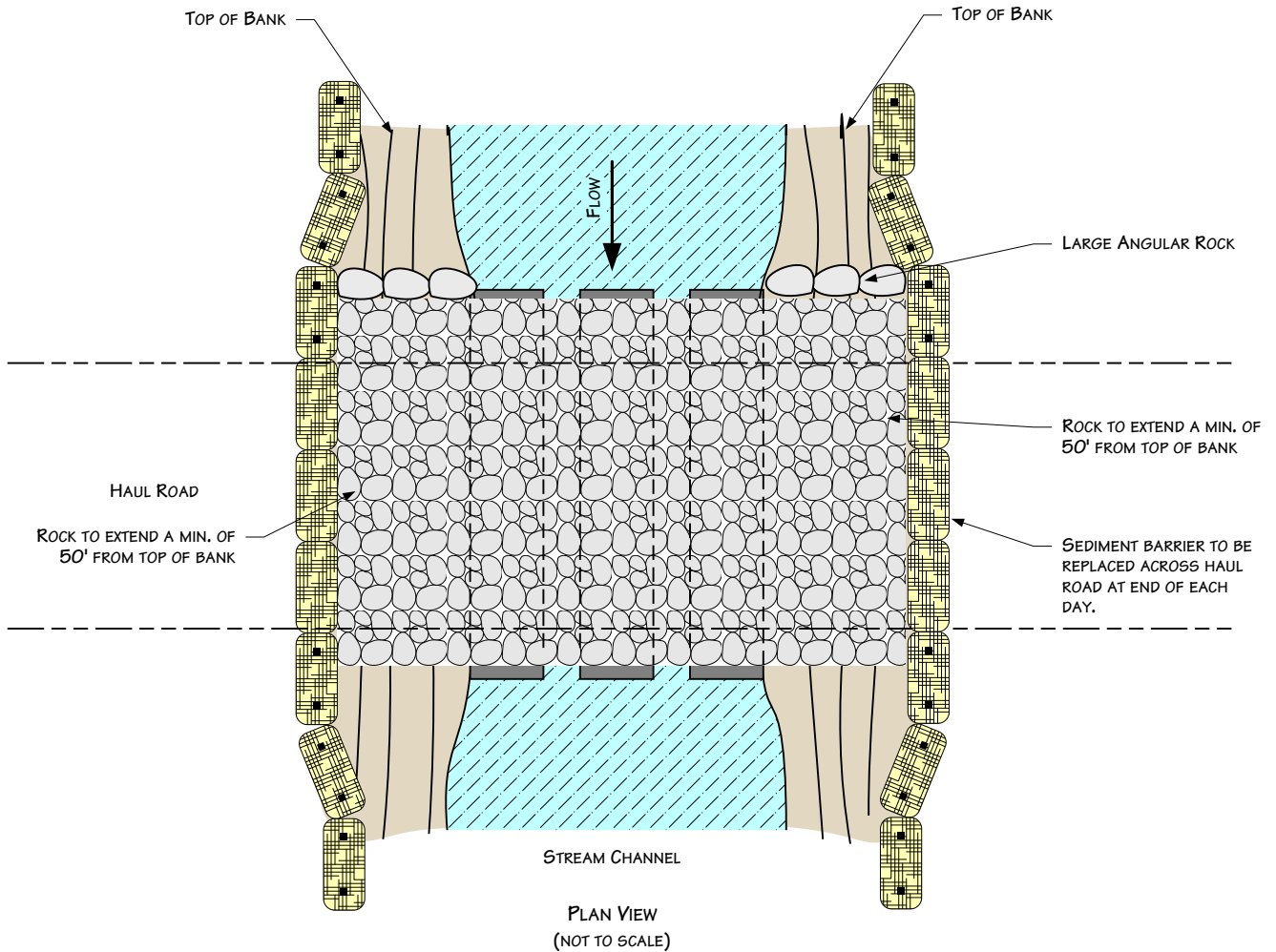
REVISED: 1/19/2009

SCALE: NTS

DRAWN BY: KMK6792

K:\335\ALBERTA\2006-135\400\2.5MN.VSD





**NOTES:**

1. STEEL FLUME PIPE(S) SIZED TO ALLOW FOR STREAM FLOW AND EQUIPMENT LOAD.
2. STRAW BALES SHALL BE PLACED ACROSS BRIDGE ENTRANCE EVERY NIGHT.
3. ADDITIONAL INFORMATION INCLUDED ON OTHER DRAWINGS.

For environmental review purposes only.



**Figure 18**  
**Environmental Mitigation Plan**  
**Typical Rock Flume Bridge**

DATE: 5/25/2001

REVISED: 10/24/08

SCALE: NTS

DRAWN BY: KMKENDALL

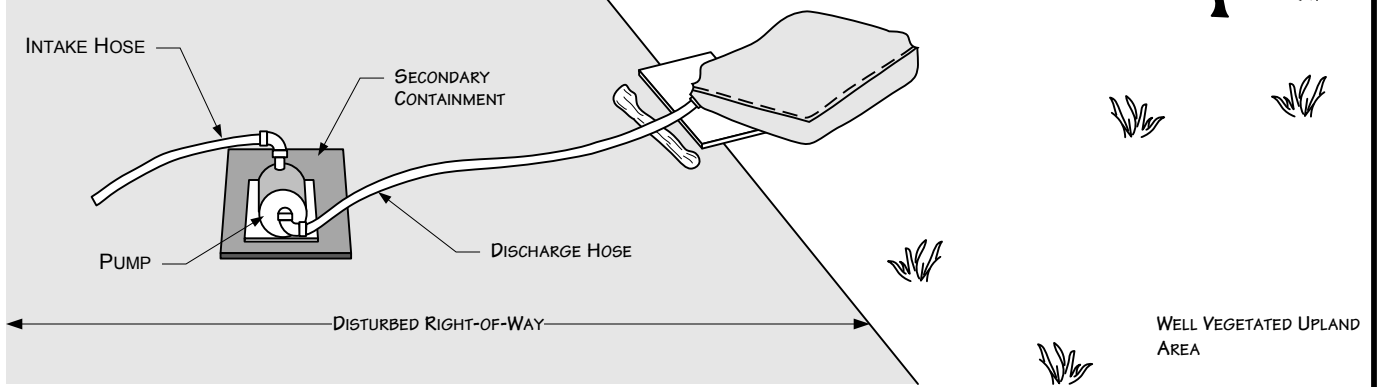
K:\335\ALBERTA\2006-135\400\2.6.VSD



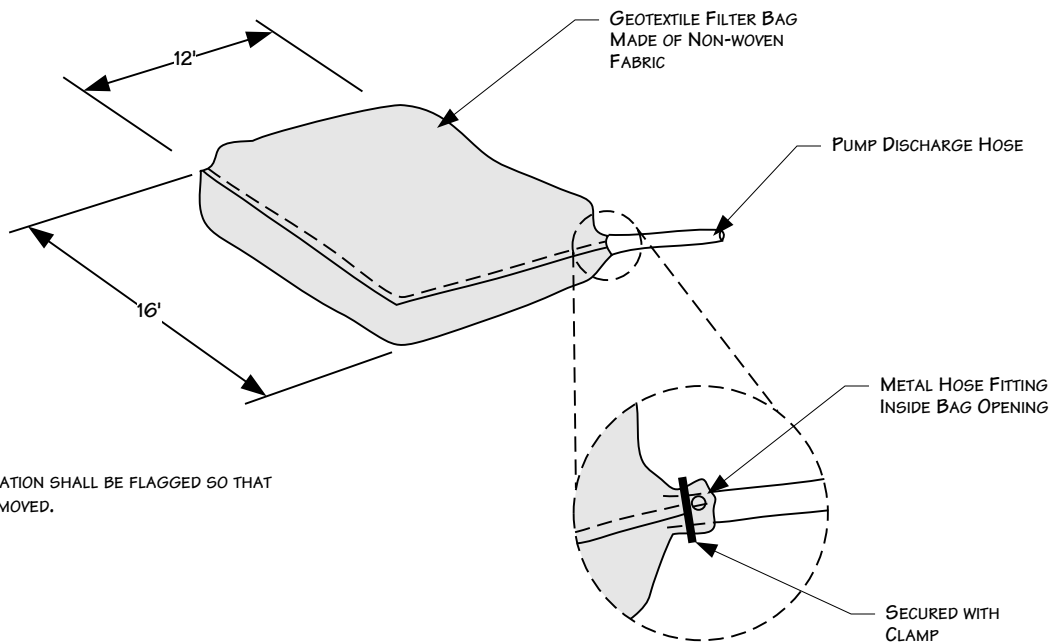
## DEWATERING DISCHARGE IN WELL VEGETATED UPLANDS

**NOTES:**

1. PUMP INTAKE HOSE MUST BE SECURED AT LEAST ONE FOOT ABOVE THE TRENCH BOTTOM.
2. DEWATER INTO GEOTEXTILE FILTER BAG OR STRAW BALE DEWATERING STRUCTURE.



## GEOTEXTILE FILTER BAG



**NOTE:**

1. FILTER BAG LOCATION SHALL BE FLAGGED SO THAT BAG CAN BE REMOVED.

For environmental review purposes only.



**Figure 19**  
Environmental Mitigation Plan  
Typical Dewatering Measures

DATE: 5/25/2001

REVISED: 1/16/2009

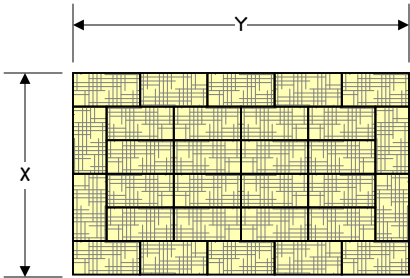
SCALE: NTS

DRAWN BY: KMKENDALL

K:\335\ALBERTA\2006-135\400\2.7.VSD

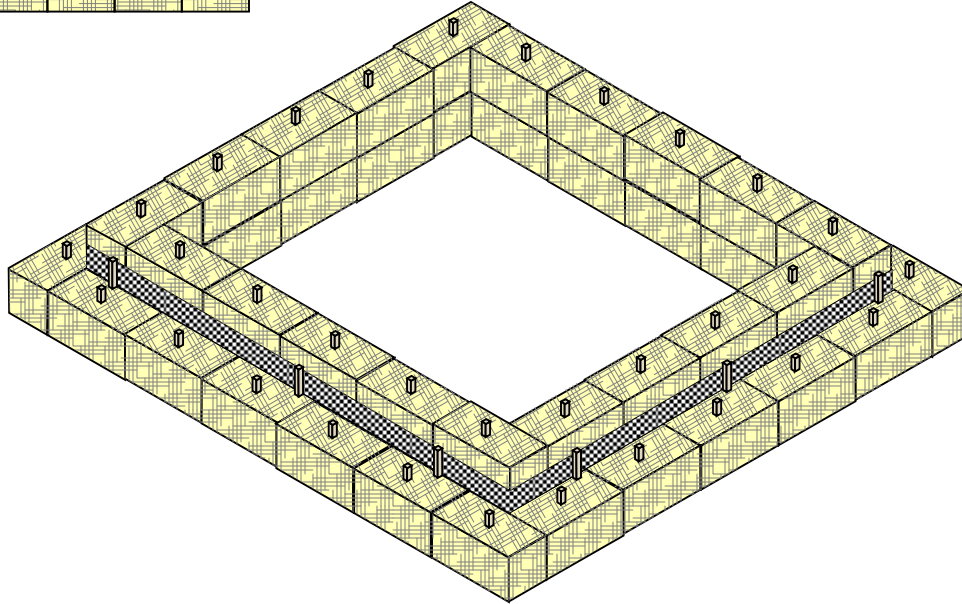




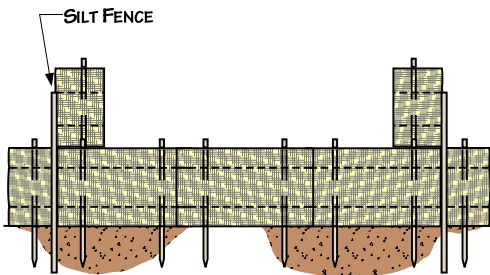


NOTES

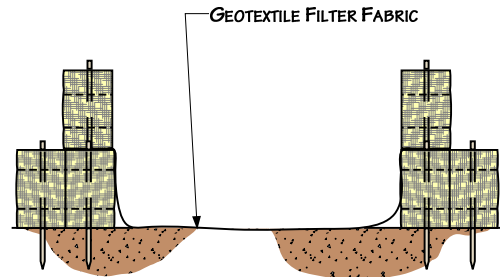
1. ARRANGE THE STRAW BALES TO THE X AND Y DIMENSIONS AS SPECIFIED BELOW.
2. IF BOTTOM OF STRUCTURE IS NOT LINED WITH STRAW BALES (OPTION 1), LINE ENTIRE STRUCTURE WITH GEOTEXTILE FILTER FABRIC.



PERSPECTIVE VIEW



OPTION 1



OPTION 2


MINIMUM SUMP DIMENSIONS (FEET)		MAXIMUM PUMPING RATE GALLONS PER MINUTE
X	Y	
10	20	300
15	20	350
20	20	400
20	25	450
25	25	500
25	30	550
30	30	660

For environmental review purposes only.

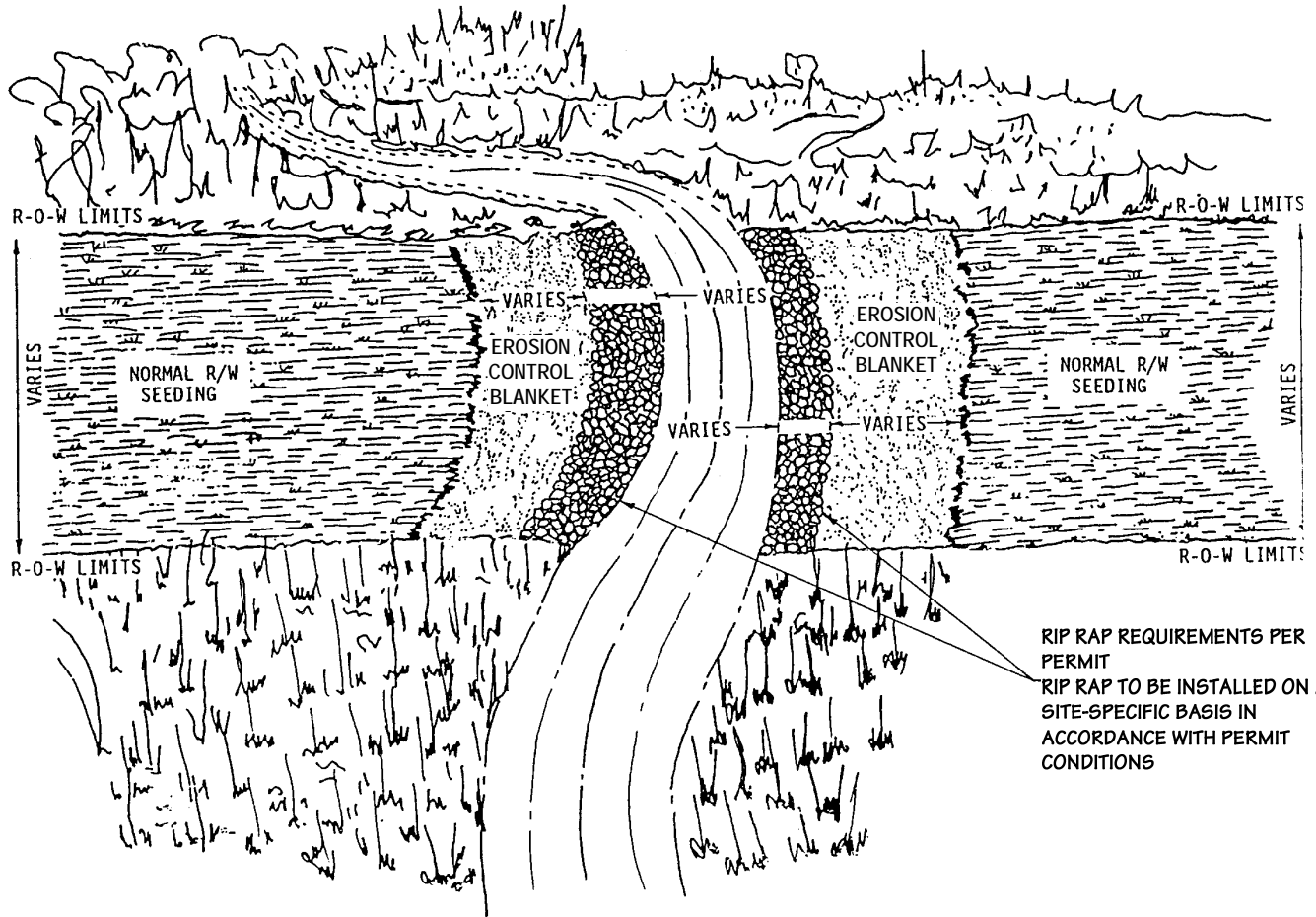


**Figure 20**  
**Environmental Mitigation Plan**  
**Typical Straw-Bale Dewatering Structure**

DATE: 5/25/2001  
 REVISED: 10/24/08  
 SCALE: NTS  
 DRAWN BY: KMKENDALL  
 K:\335\ALBERTA\2006-135\400\2.8.VSD



NOTE: PLACE JUTE BLANKET A MINIMUM OF ONE (1) FOOT UNDER RIP RAP. EXTEND JUTE BLANKET FROM MEAN HIGH WATER LEVEL TO SEVERAL FEET BEHIND HIGH BANK.



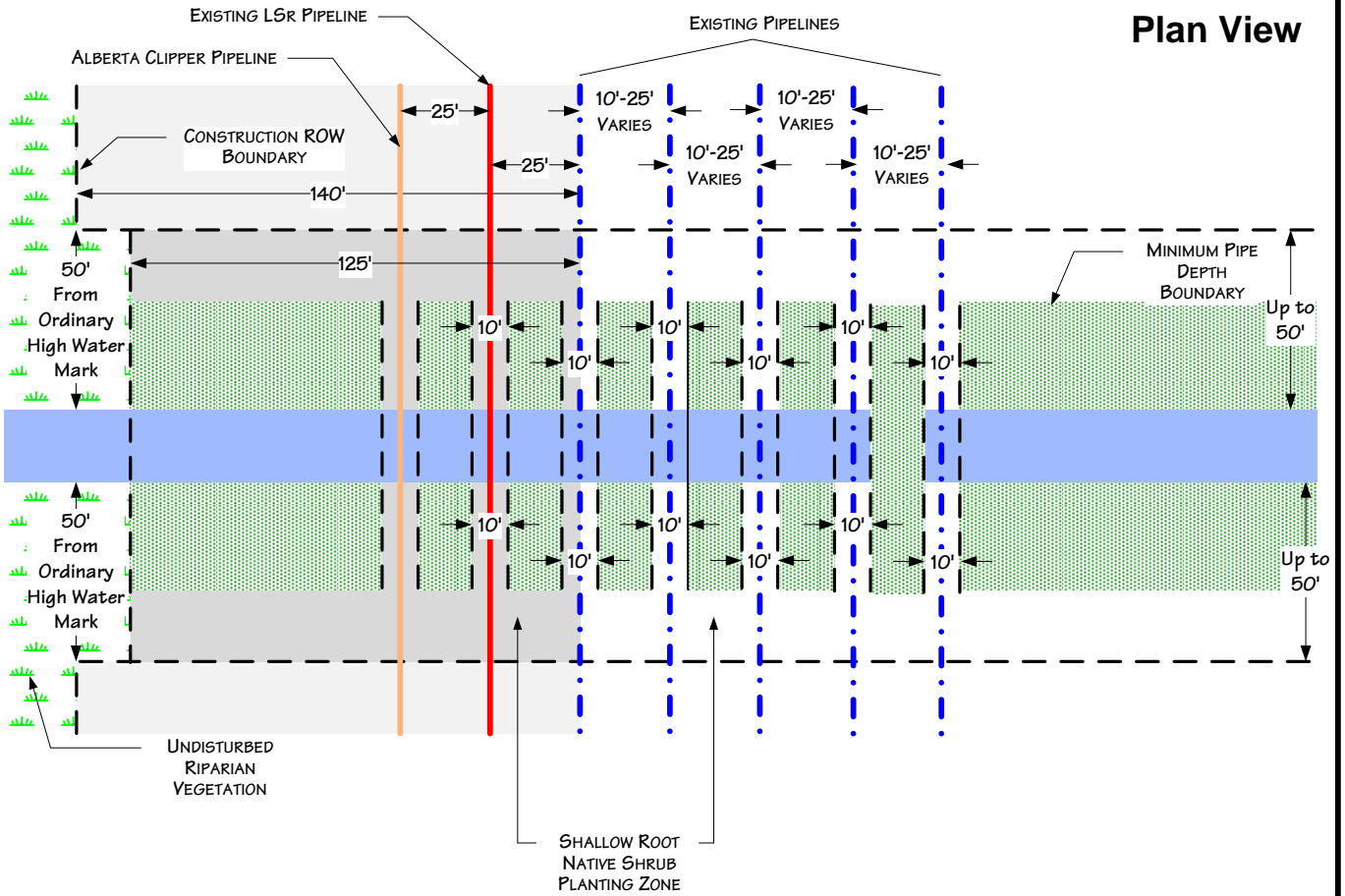
For environmental review purposes only.



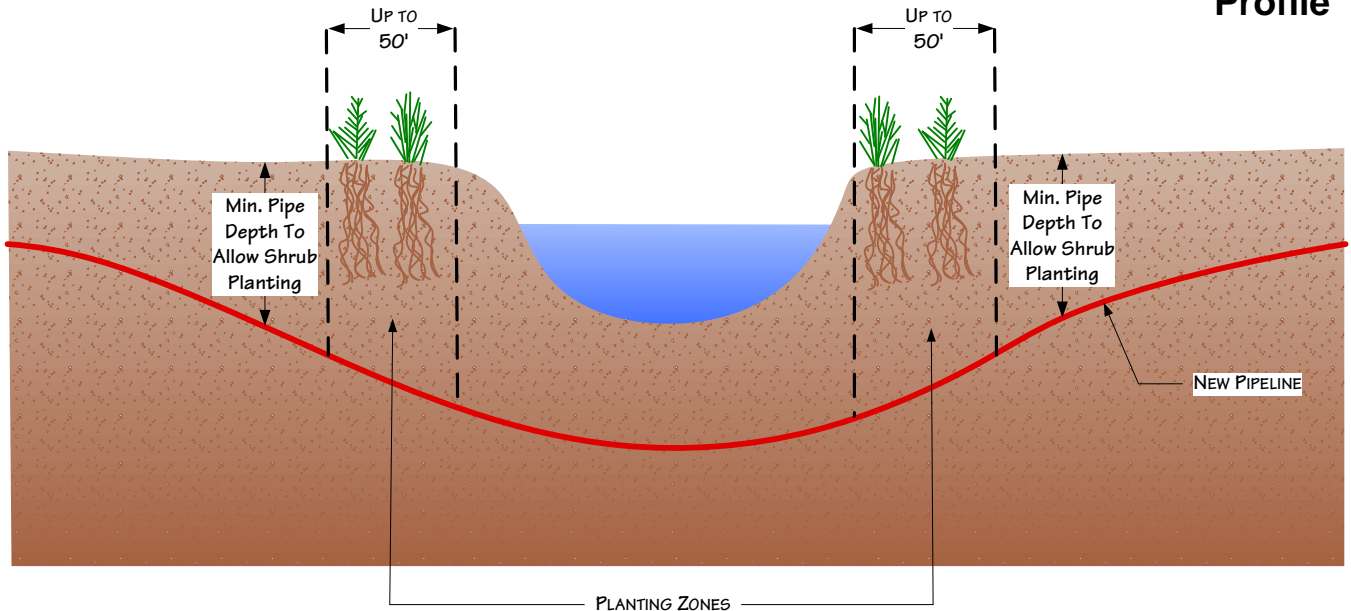
**Figure 21**  
**Environmental Mitigation Plan**  
 Typical Final Stream Bank Stabilization  
 Rip Rap & Erosion Control

DATE: 7/19/2000	
REVISED: 1/16/2009	
SCALE: NTS	
DRAWN BY: KMKENDALL	
K:\335\ALBERTA\2006-135\400\7.3.VSD	

# Plan View



# Profile



For environmental review purposes only.



**Figure 22A**  
**Environmental Mitigation Plan**  
 Alberta Clipper Stream Crossing  
 Replanting Typical  
 (Neché, ND to Clearbrook, MN)

DATE: 11/29/2005

REVISED: 1/20/2009

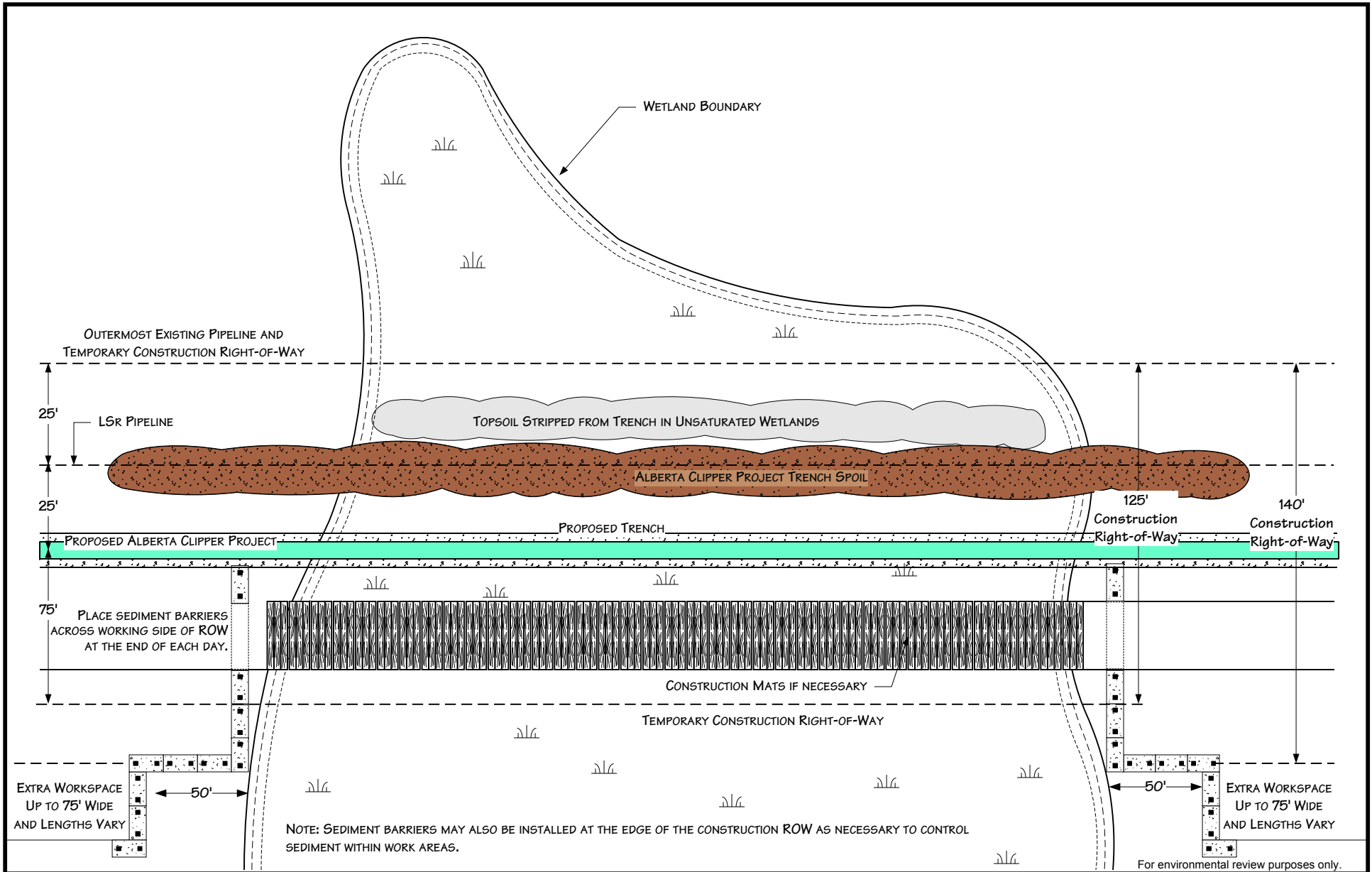
SCALE: NTS

DRAWN BY: KJA

K:\335MN\_EMP\FIGURE22A.VSD

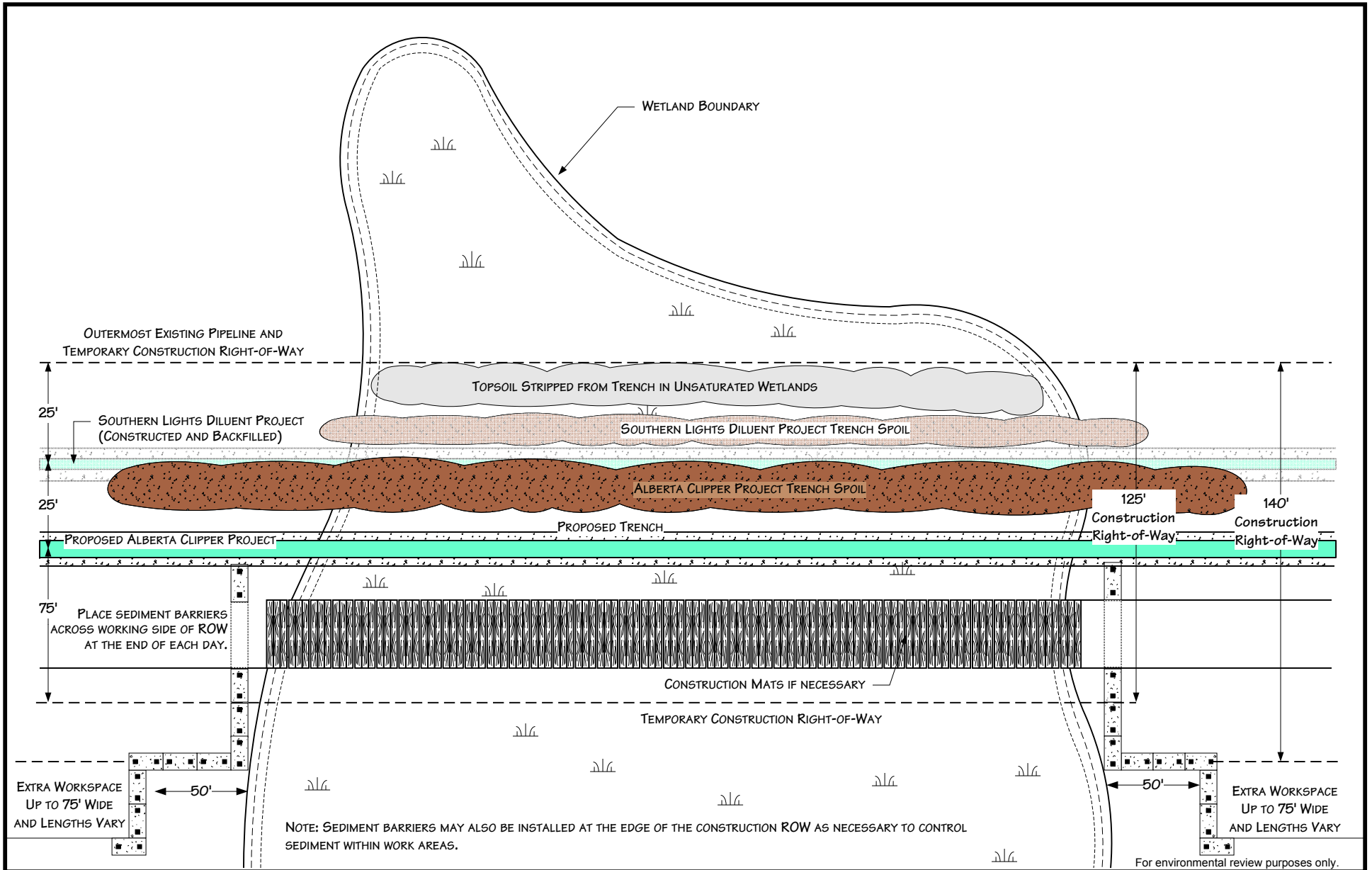






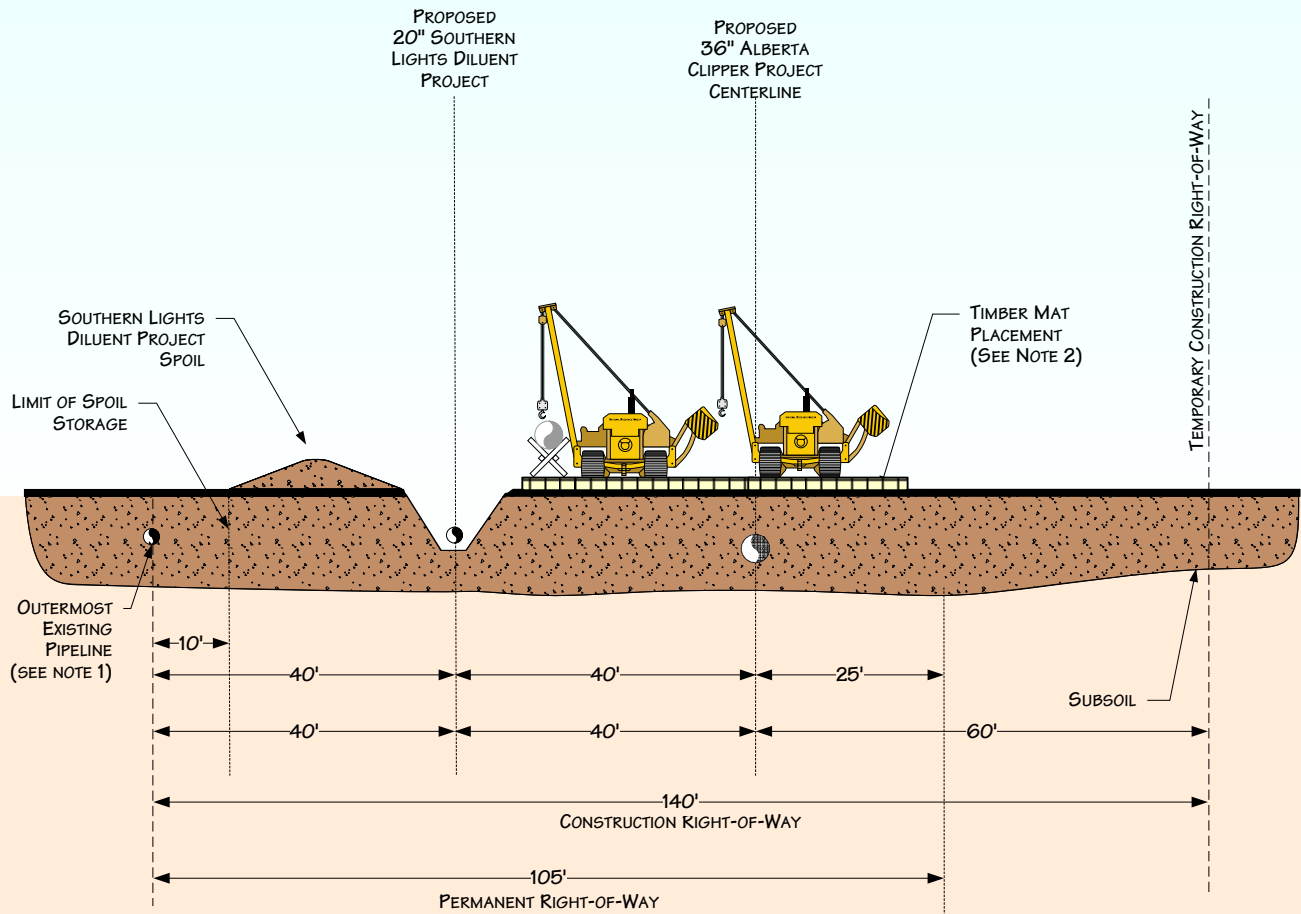
**Figure 23A**  
**Environmental Mitigation Plan**  
 Typical Wetland Crossing Method  
 (Neche, ND to Clearbrook, MN)

DATE: 5/25/2001	
REVISED: 1/20/2009	
SCALE: NTS	
DRAWN BY: KMKENDALL	
K:\335\MN_EMP\FIGURE23A.VSD	



**Figure 23B**  
**Environmental Mitigation Plan**  
 Typical Wetland Crossing Method  
 (Clearbrook, MN to Superior, WI)

DATE: 5/25/2001	
REVISED: 1/20/2009	
SCALE: NTS	
DRAWN BY: KMKENDALL	
K:\335\MN_EMP\FIGURE23B.VSD	



**PROFILE**

**NOTES:**

1. THE OFFSET FROM THE OUTERMOST EXISTING PIPELINE WILL BE 40' FOR MOST LOCATIONS BUT MAY BE INCREASED OR DECREASED DEPENDING ON THE SITE SPECIFIC CONSTRUCTION REQUIREMENTS.
2. TIMBER MATS USED IN CONSTRUCTION OF SOUTHERN LIGHTS DILUENT PIPELINE WILL BE SLID OVER AND REUSED FOR THE CONSTRUCTION OF THE ALBERTA CLIPPER PIPELINE.
3. BECAUSE OF THE EXTENSIVE NATURE OF WETLANDS CROSSED AND THE LACK OF SUITABLE ROADS FOR MOVE-AROUNDS, ALL CONSTRUCTION EQUIPMENT MAY NEED TO TRAVERSE THE RIGHT-OF-WAY USING A TIMBER MAT PASSING LANE DESIGNED TO ACCOMMODATE CONSTRUCTION TRAFFIC.

For environmental review purposes only



**Figure 24**  
**Environmental Mitigation Plan**  
 Right-of-Way Configuration  
 Summer Saturated Wetland Construction  
 20" Southern Lights Construction

DATE: 5/23/2007

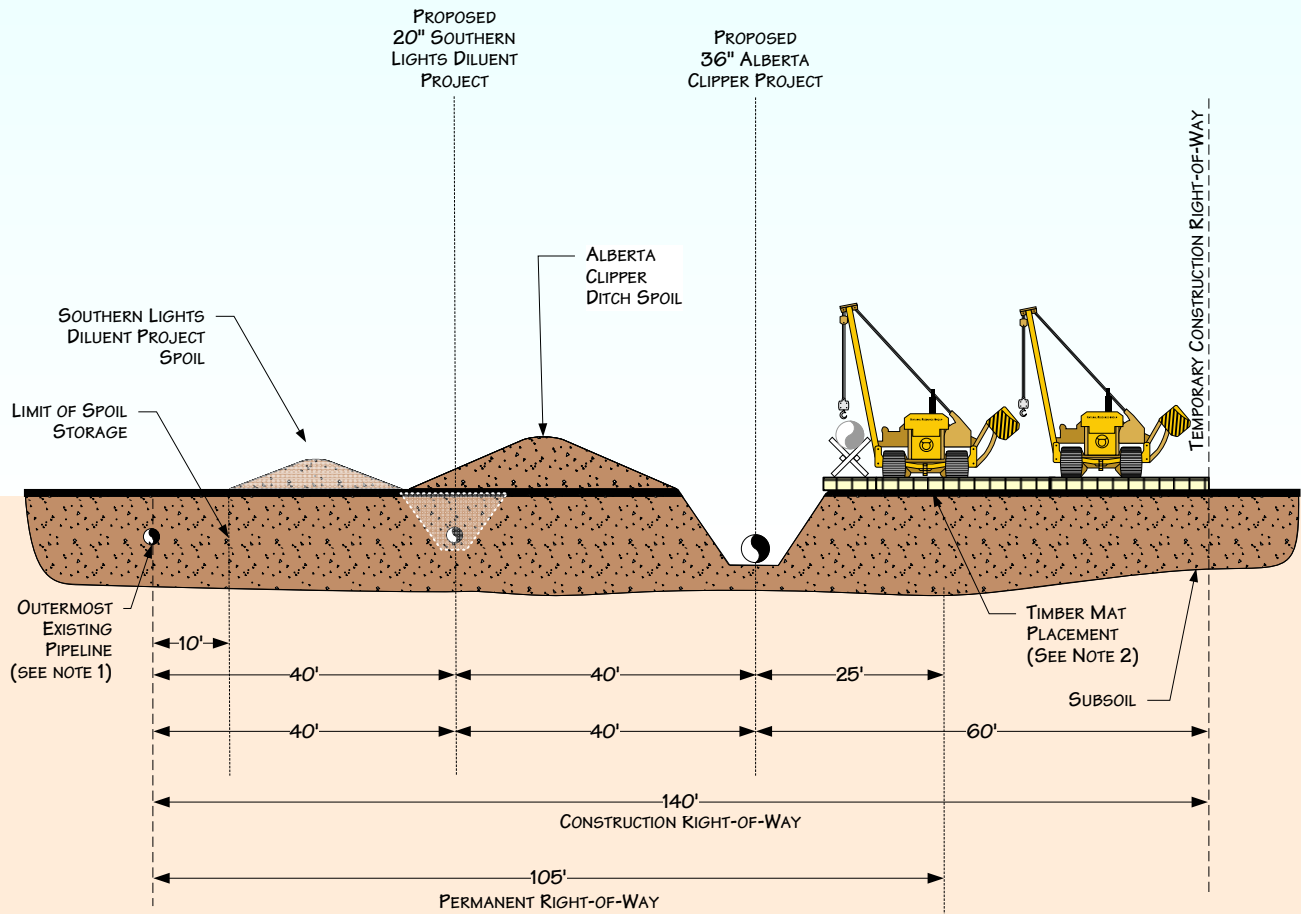
REVISED: 1/19/09

SCALE: NTS

DRAWN BY: AKR

K:\335\MN\_EMP\FIGURE24.VSD





**PROFILE**

**NOTES:**

1. THE OFFSET FROM THE OUTERMOST EXISTING PIPELINE WILL BE 40' FOR MOST LOCATIONS BUT MAY BE INCREASED OR DECREASED DEPENDING ON THE SITE SPECIFIC CONSTRUCTION REQUIREMENTS.
2. TIMBER MATS USED IN CONSTRUCTION OF SOUTHERN LIGHTS DILUENT PIPELINE WILL BE SLID OVER AND REUSED FOR THE CONSTRUCTION OF THE ALBERTA CLIPPER PIPELINE.
3. BECAUSE OF THE EXTENSIVE NATURE OF WETLANDS CROSSED AND THE LACK OF SUITABLE ROADS FOR MOVE-AROUNDS, ALL CONSTRUCTION EQUIPMENT MAY NEED TO TRAVERSE THE RIGHT-OF-WAY USING A TIMBER MAT PASSING LANE DESIGNED TO ACCOMMODATE CONSTRUCTION TRAFFIC.

For environmental review purposes only



**Figure 25**  
**Environmental Mitigation Plan**  
 Right-of-Way Configuration  
 Summer Saturated Wetland Construction  
 36" Alberta Clipper Construction

DATE: 5/23/2007

REVISED: 1/19/09

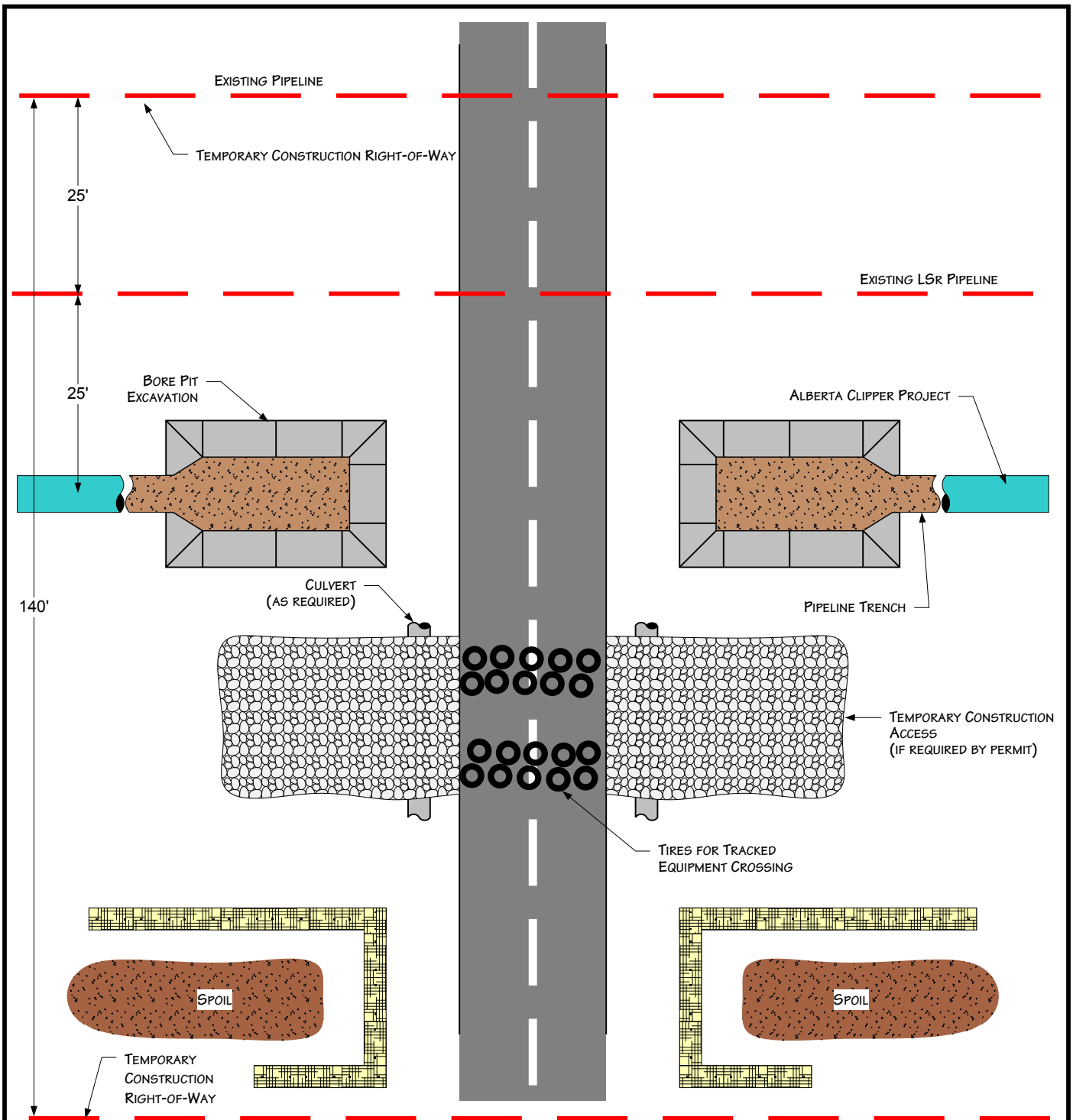
SCALE: NTS

DRAWN BY: AKR

K:\335\MN\_EMP\FIGURE25.VSD







PLAN VIEW

NOTES

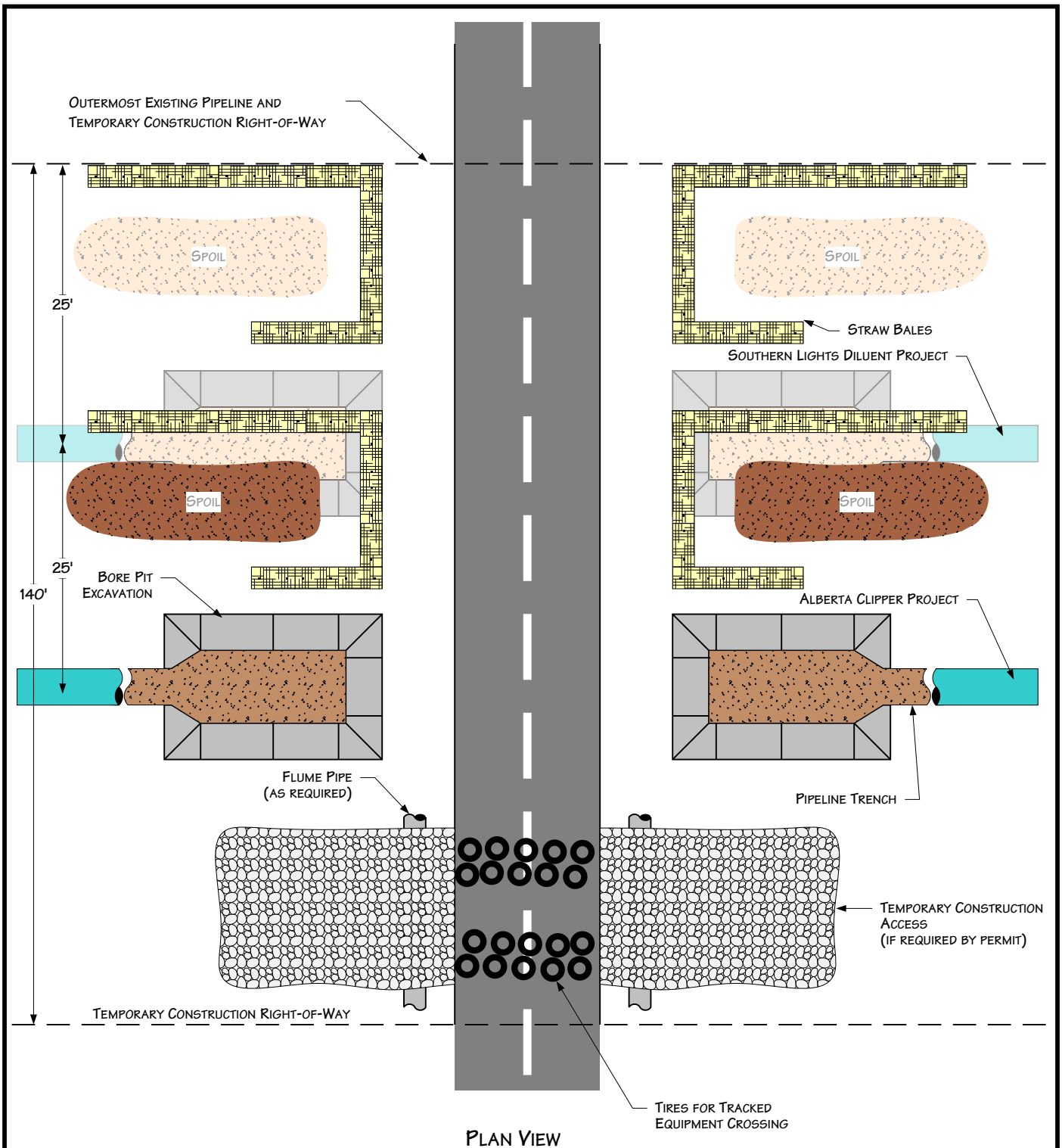
1. PROCEDURES SHOWN IN THIS DRAWING APPLY TO IMPROVED ROADS.
2. ROADS MUST BE CLEANED AFTER EQUIPMENT CROSSES AND DIRT PLACED IN SPOIL CONTAINMENT AREAS.
3. TEMPORARY ACCESS MATERIALS MUST BE REMOVED UPON PROJECT COMPLETION.
4. ADDITIONAL INFORMATION INCLUDED ON OTHER DRAWINGS OR PERMITS.
5. CONSTRUCTION AREAS LOCATED OUTSIDE ROAD ROW.

For environmental review purposes only.



**Figure 26A**  
**Environmental Mitigation Plan**  
 Typical Improved Road Crossing  
 Directional Bore Method  
 (Neché, ND to Clearbrook, MN)

DATE: 7/13/1999	
REVISED: 1/22/2009	
SCALE: NTS	
DRAWN BY: KMKENDALL	
K:\335\MN_EMP\FIGURE26A.VSD	



PLAN VIEW

NOTES

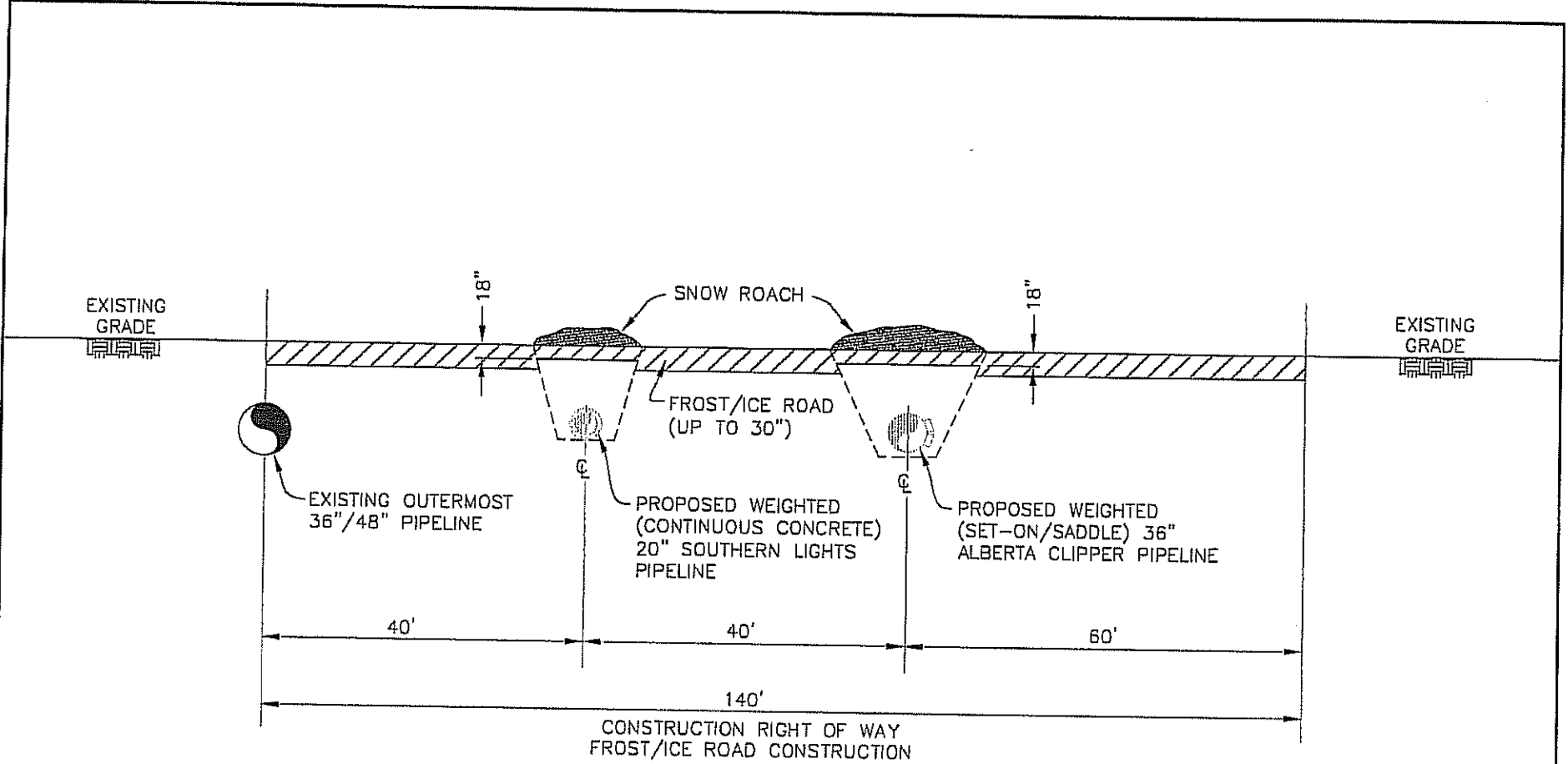
1. PROCEDURES SHOWN IN THIS DRAWING APPLY TO IMPROVED ROADS.
2. ROADS MUST BE CLEANED AFTER EQUIPMENT CROSSES AND DIRT PLACED IN SPOIL CONTAINMENT AREAS.
3. TEMPORARY ACCESS MATERIALS MUST BE REMOVED UPON PROJECT COMPLETION.
4. ADDITIONAL INFORMATION INCLUDED ON OTHER DRAWINGS OR PERMITS.
5. CONSTRUCTION AREAS LOCATED OUTSIDE ROAD ROW.

For environmental review purposes only.

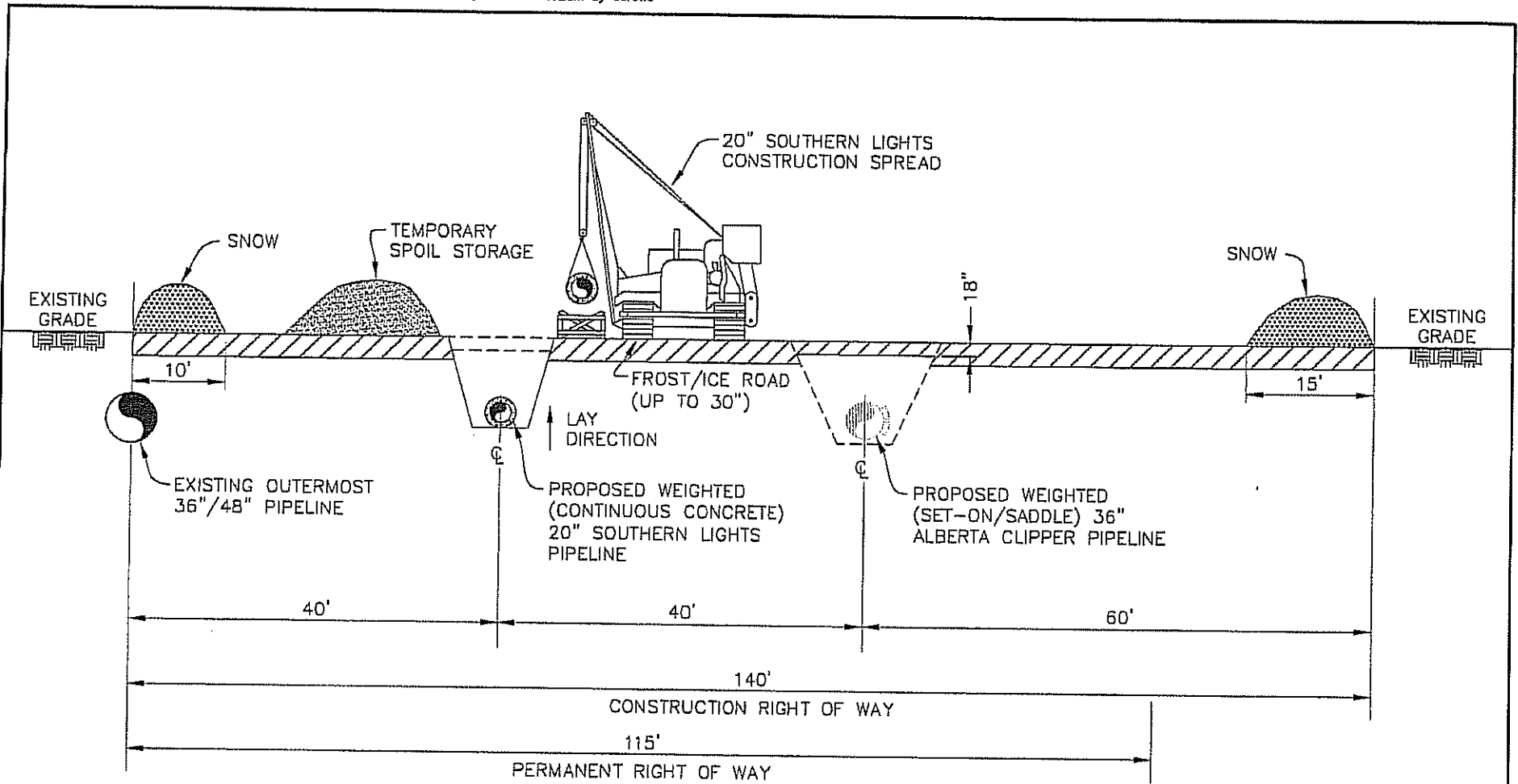




**Figure 26B**  
**Environmental Mitigation Plan**  
 Typical Improved Road Crossing  
 Directional Bore Method  
 (Clearbrook, MN to Superior, WI)

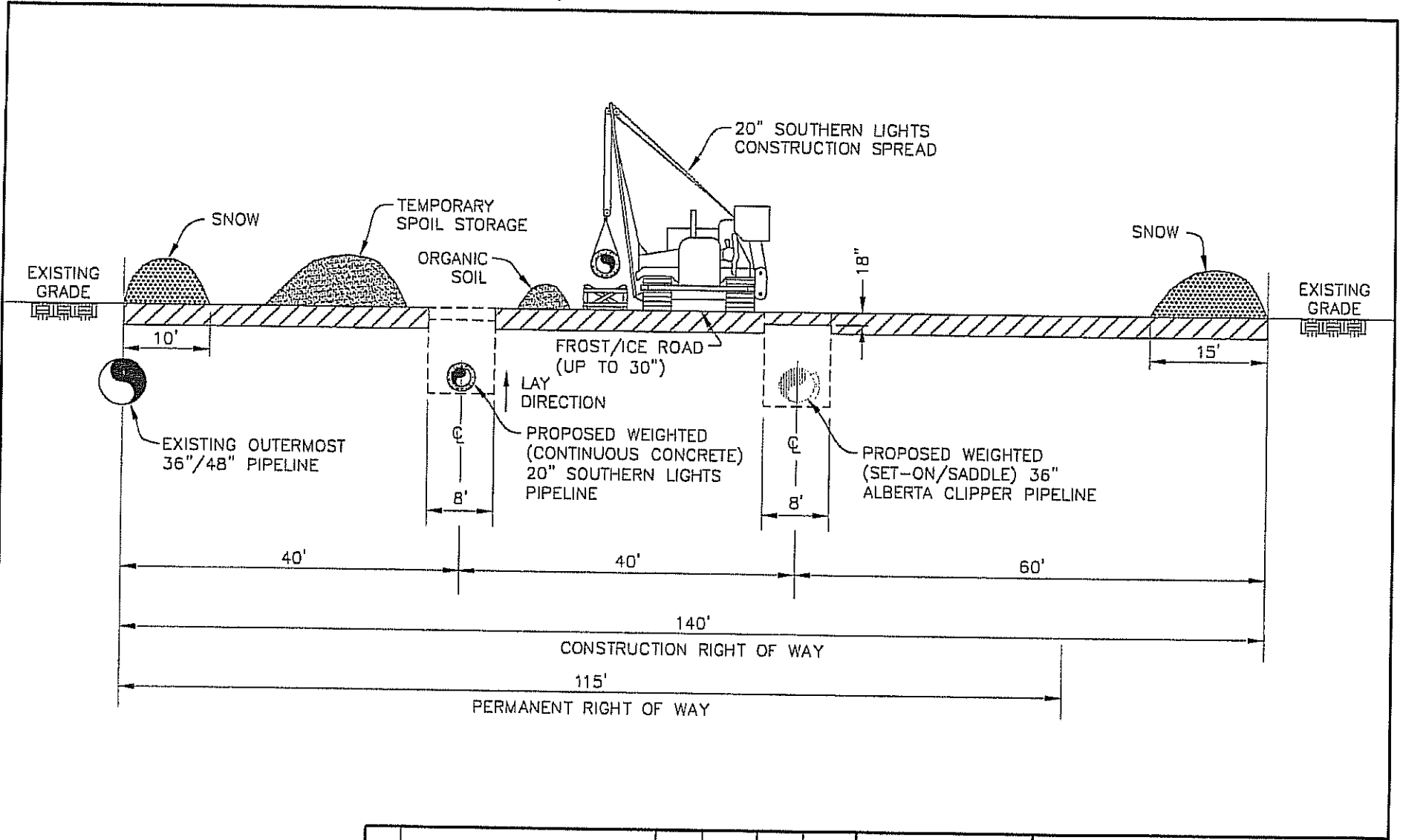
DATE: 7/13/1999	NATURAL RESOURCE GROUP
REVISED: 1/22/2009	
SCALE: NTS	
DRAWN BY: KMKENDALL	
K:\335\MN_EMP\FIGURE27B.VSD	





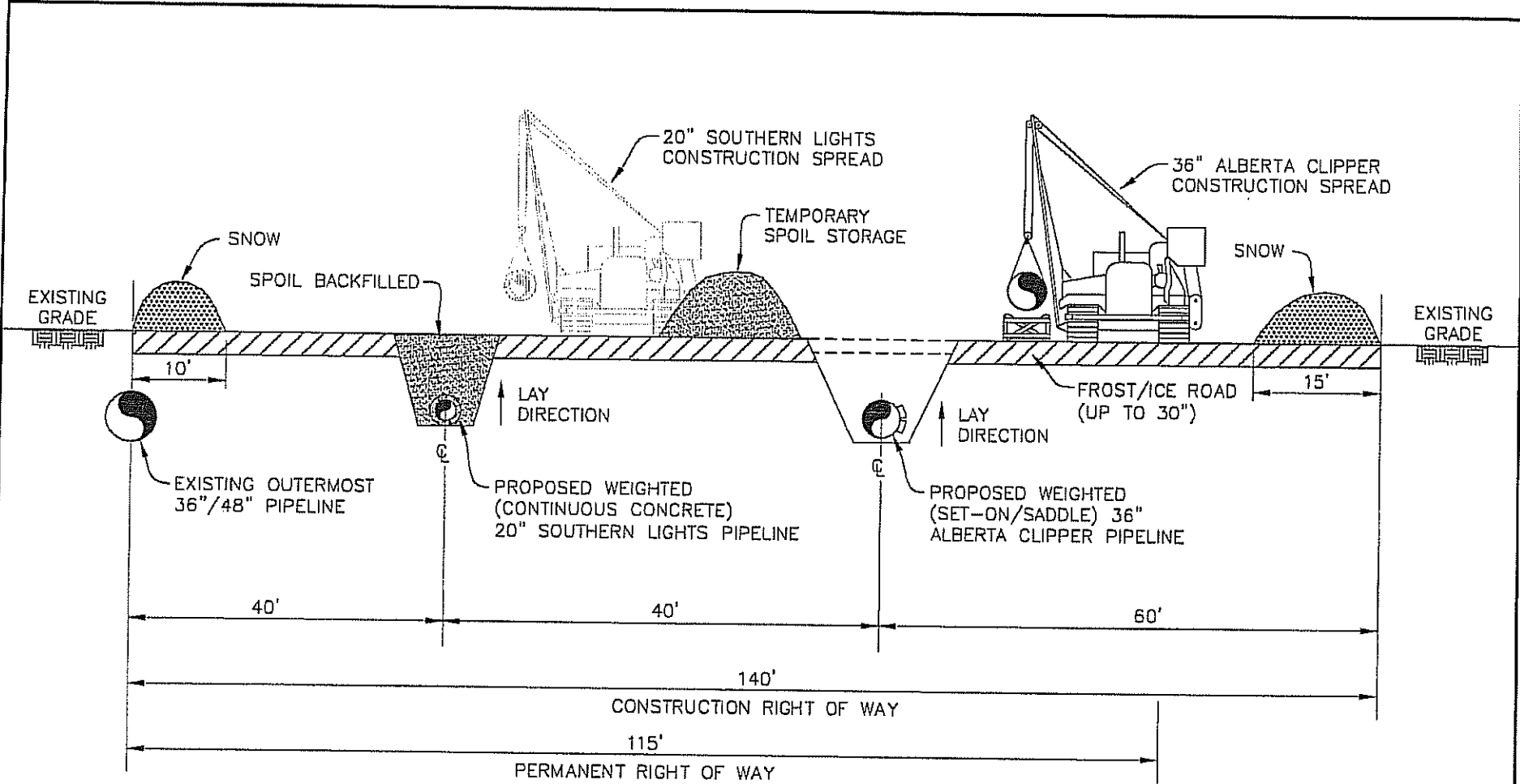
						<b>GULF INTERSTATE ENGINEERING</b> HOUSTON, TEXAS		<b>ENBRIDGE</b> Enbridge Energy, Limited Partnership		
						DRN. ENR	GIE	DATE	11/15/07	WINTER WETLAND CONSTRUCTION FROST/ICE ROAD CONSTRUCTION RIGHT OF WAY CONFIGURATION <b>Figure 27</b>
						CHK.	JC	DATE	11/15/07	
						PROJ. ENGR.	RH	DATE	11/15/07	
						PROJ. MGR.	DC	DATE	11/15/07	
NO.	REVISION-DESCRIPTION	BY	DATE	CHK'D	APP'D	CLIENT APP.	SCALE		N.T.S.	DWG. NO.
										A-65/67-1.77-FIG01-A



						 <b>GULF INTERSTATE ENGINEERING</b> HOUSTON, TEXAS		 <b>ENBRIDGE</b> Enbridge Energy, Limited Partnership		
						DWN. BY: GIE CHK: JC PROJ. ENGR: RH PROJ. MGR: DC	DATE: 11/15/07 11/15/07 11/15/07 11/15/07	WINTER SATURATED WETLAND CONSTRUCTION 20" SOUTHERN LIGHTS CONSTRUCTION RIGHT OF WAY CONFIGURATION <b>Figure 28</b>		
NO.	REVISION-DESCRIPTION	BY	DATE	CHK'D	APP'D	CLIENT APP.	SCALE	DWG. NO.		
							N.T.S.	A-65/67-1.77-FIG02-A		

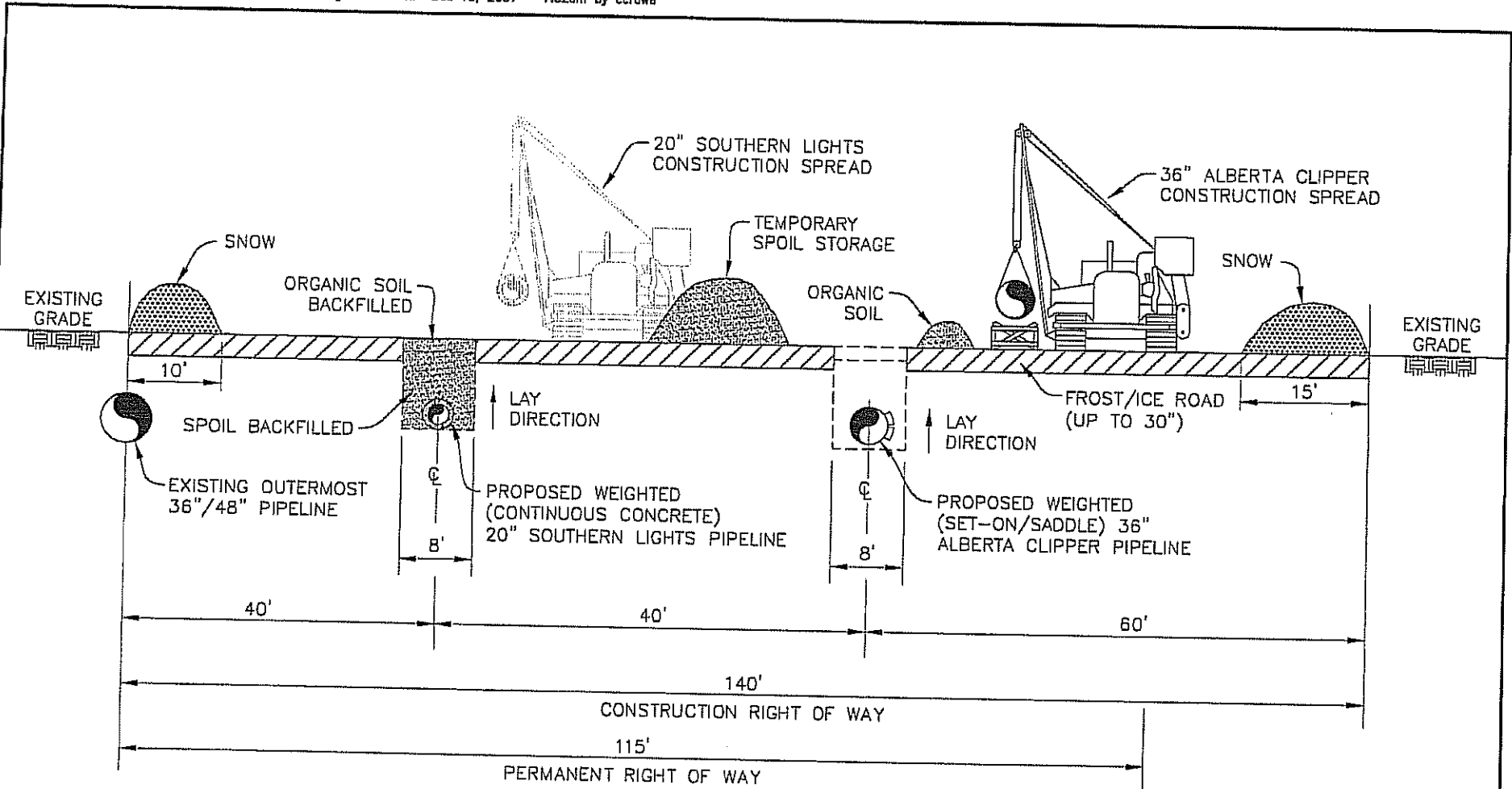


						 <b>GULF INTERSTATE ENGINEERING</b> HOUSTON, TEXAS		 <b>ENBRIDGE</b> Enbridge Energy, Limited Partnership	
						DWN. BY: GIE	DATE: 11/15/07	WINTER NON-SATURATED WETLAND CONSTRUCTION 20" SOUTHERN LIGHTS CONSTRUCTION RIGHT OF WAY CONFIGURATION <b>Figure 29</b>	
						CHK: JC	DATE: 11/15/07		
						PROJ. ENGR: RH	DATE: 11/15/07		
						PROJ. WGR: DC	DATE: 11/15/07		
NO.	REVISION-DESCRIPTION	BY	DATE	CHK'D	APP'D	CLIENT APP.	SCALE: N.T.S.	DWG. NO.: A-65/67-1.77-FIG02A-A	



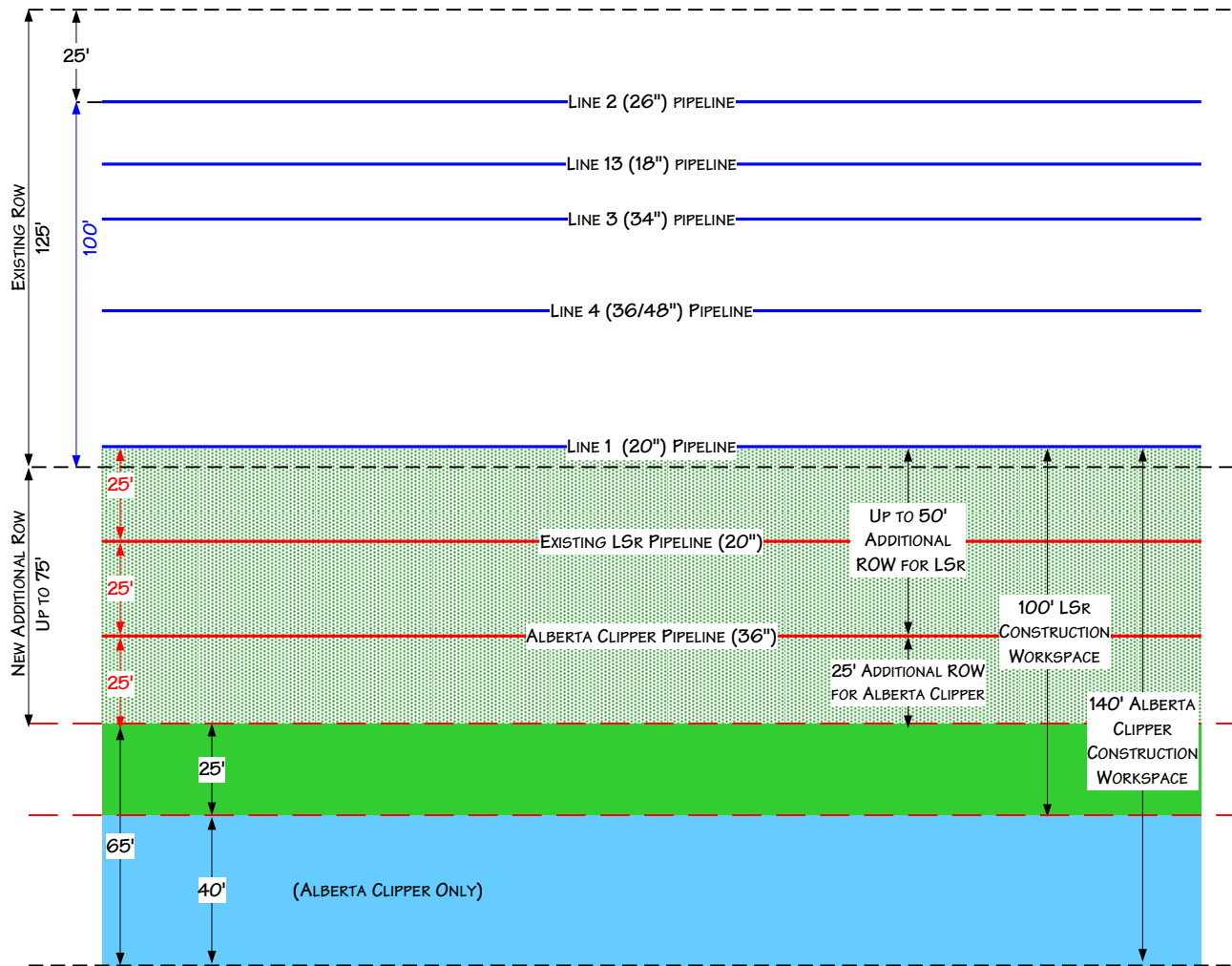
					<b>GULF INTERSTATE ENGINEERING</b> HOUSTON, TEXAS		<b>ENBRIDGE</b> Enbridge Energy, Limited Partnership	
					DWN. BY:	GIE	DATE	11/15/07
					CHK.	JC	DATE	11/15/07
					PROJ. ENGR.	RH	DATE	11/15/07
					PROJ. MGR.	DC	DATE	11/15/07
NO.	REVISION-DESCRIPTION	BY	DATE	CHK'D	APP'D	CLIENT APP.	SCALE	DWG. NO.
							N.T.S.	A-65/67-1.77-FIG03-A

WINTER SATURATED WETLAND CONSTRUCTION  
 36" ALBERTA CLIPPER CONSTRUCTION  
 RIGHT OF WAY CONFIGURATION  
**Figure 30**



					<b>GULF INTERSTATE ENGINEERING</b> HOUSTON, TEXAS		<b>ENBRIDGE</b> Enbridge Energy, Limited Partnership	
					DWN. BY:	GIE	DATE	11/15/07
					CHK.	JC	DATE	11/15/07
					PRCL. ENGR.	RH	DATE	11/15/07
					PRCL. MGR.	DC	DATE	11/15/07
NO.	REVISION-DESCRIPTION	BY	DATE	CHK'D	APP'D	CLIENT APP.	SCALE	DWG. NO.
							N.T.S.	A-65/67-1.77-FIG03A-A

WINTER NON-SATURATED WETLAND CONSTRUCTION  
 36" ALBERTA CLIPPER CONSTRUCTION  
 RIGHT OF WAY CONFIGURATION  
**Figure 31**



- EXISTING ROW BOUNDARY IS 25' NORTH OF THE NORTHERN-MOST EXISTING PIPELINE TO 100' SOUTH OF THE NORTHERN-MOST EXISTING PIPELINE.
- BECAUSE PIPELINE SPACING VARIES DUE TO CONSTRUCTION REQUIREMENTS AT THE TIME OF INSTALLATION, THE DISTANCE BETWEEN THE SOUTHERN MOST LINE (LINE 1) AND SOUTHERN EXISTING ROW BOUNDARY VARIES.
- NEW ADDITIONAL ROW REQUIREMENTS WILL VARY ALONG THE PROPOSED ROUTE FROM THE MINNESOTA/WISCONSIN BORDER TO THE CANADA/NORTH DAKOTA BORDER. THESE ROW REQUIREMENTS WILL DEPEND ON THE LOCATION OF ENBRIDGE'S SOUTHERN MOST EXISTING LINE AND THE EXISTING ROW BOUNDARY. ENBRIDGE WILL NEED UP TO 50 FEET OF ADDITIONAL PERMANENT ROW FOR THE LSR PROJECT, AND WILL NEED ANOTHER 25 FEET OF ADDITIONAL PERMANENT ROW FOR THE ALBERTA CLIPPER PROJECT. THIS ADDITIONAL 25 FEET OF THE PERMANENT ROW FOR THE ALBERTA CLIPPER PROJECT IS NECESSARY TO ALLOW FOR APPROXIMATELY 25-FOOT SPACING BETWEEN THE PROPOSED LSR AND ALBERTA CLIPPER PROJECTS, WHILE ALSO ALLOWING FOR A BUFFER TO THE SOUTHERNMOST PERMANENT ROW BOUNDARY.
- TEMPORARY WORKSPACE ADJACENT TO NEW ADDITIONAL ROW WILL BE REQUIRED TO INSTALL THE PIPELINE(S). TYPICALLY 65' IN WIDTH AND THE LENGTH OF THE ROW WILL BE RENTED FROM LANDOWNERS. ADDITIONAL TEMPORARY WORKSPACE AT CIVIL AND ENVIRONMENTAL CROSSINGS OF UP TO 75' IN WIDTH AND UP TO 300' IN LENGTH ON EACH SIDE OF THE CROSSING WILL BE RENTED (NOT SHOWN).
- ENBRIDGE WILL USE THE RECENTLY DISTURBED ROW OVER THE NEWLY-CONSTRUCTED LSR LINE FOR SPOIL STORAGE DURING CONSTRUCTION OF THE PROPOSED ALBERTA CLIPPER PIPELINE.

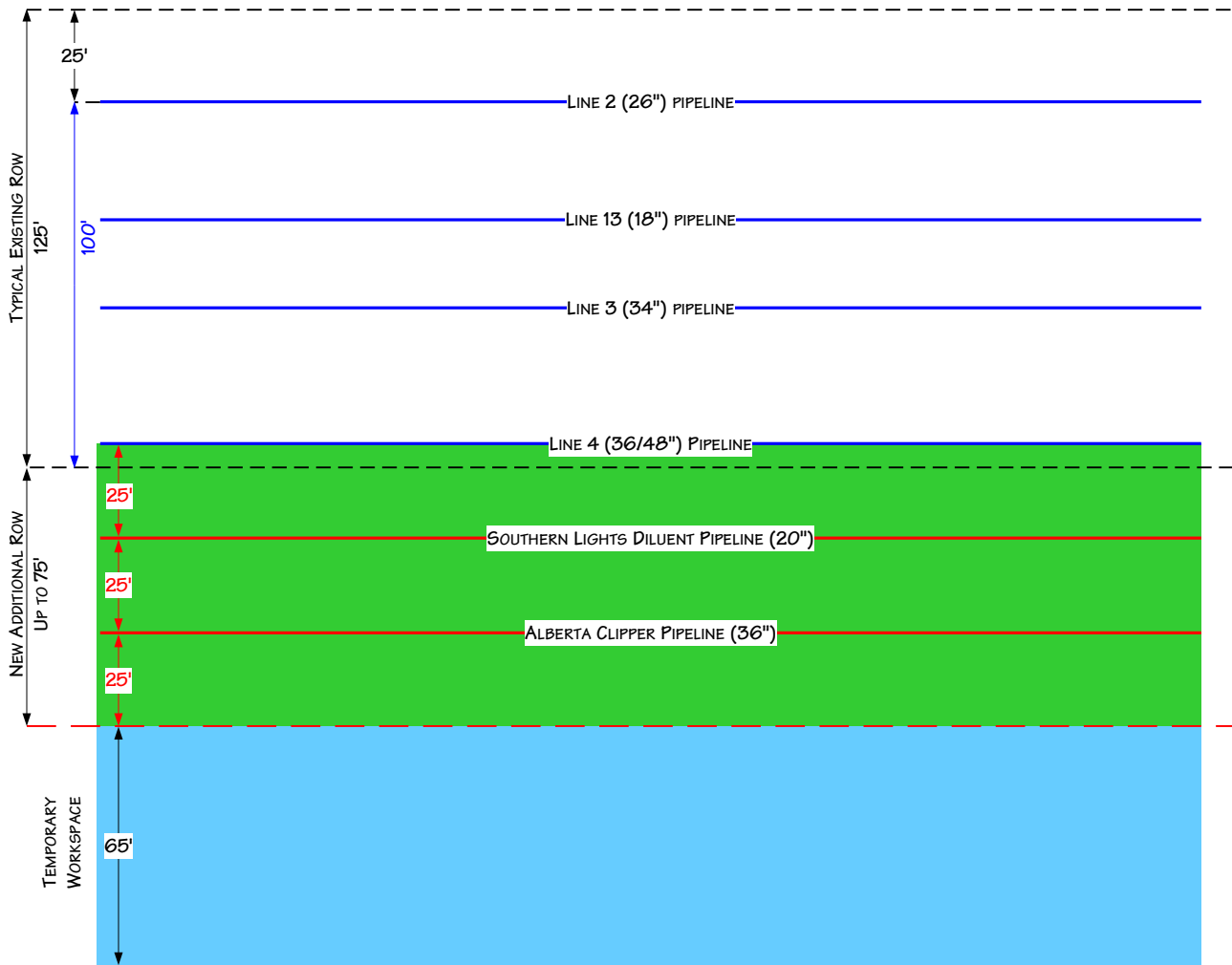
For environmental review purposes only



**Figure 32A**  
**Environmental Mitigation Plan**  
 Right-of-Way Configuration  
 (Neché, ND to Clearbrook, MN)

DATE: 5/7/2004	
REVISED: 1/22/2009	
SCALE: NTS	
DRAWN BY: KMK6792	
K:\335\MN_EMP\FIGURE32A.VSD	





- TYPICAL EXISTING ROW BOUNDARY DEFINED BY LOCATION OF NORTHERN MOST PIPELINE: 25 FEET TO THE NORTH AND 100 FEET TO THE SOUTH.
- BECAUSE PIPELINE SPACING VARIES DUE TO CONSTRUCTION REQUIREMENTS AT THE TIME OF INSTALLATION, THE DISTANCE BETWEEN THE SOUTHERN MOST LINE AND SOUTHERN EXISTING ROW BOUNDARY MAY VARY BETWEEN 0 AND 35 FEET.
- NEW ADDITIONAL ROW REQUIREMENTS FOR THE ALBERTA CLIPPER AND SOUTHERN LIGHTS DILUENT PROJECTS WILL VARY ALONG THE PROPOSED ROUTE FROM CLEARBROOK, MN TO MN-WI BORDER. THESE ROW REQUIREMENTS WILL DEPEND ON THE LOCATION OF ENBRIDGE'S SOUTHERN MOST EXISTING LINE AND THE EXISTING ROW BOUNDARY. ENBRIDGE WILL NEED UP TO 75 FEET OF ADDITIONAL PERMANENT ROW FOR THE ALBERTA CLIPPER AND SOUTHERN LIGHTS DILUENT PIPELINES WHICH IS NECESSARY TO ALLOW FOR APPROXIMATELY 25-FOOT SPACING BETWEEN THE SOUTHERN LIGHTS DILUENT AND ALBERTA CLIPPER PROJECTS, WHILE ALSO ALLOWING FOR A BUFFER TO THE SOUTHERNMOST PERMANENT ROW BOUNDARY.
- TEMPORARY WORKSPACE ADJACENT TO NEW ADDITIONAL ROW WILL BE REQUIRED TO INSTALL THE PIPELINE(S). TYPICALLY 65' IN WIDTH AND THE LENGTH OF THE ROW WILL BE RENTED FROM LANDOWNERS. ADDITIONAL TEMPORARY WORKSPACE AT CIVIL AND ENVIRONMENTAL CROSSINGS OF UP TO 75' IN WIDTH AND UP TO 300' IN LENGTH ON EACH SIDE OF THE CROSSING WILL BE RENTED (NOT SHOWN).

For environmental review purposes only.



**Figure 32B**  
**Environmental Mitigation Plan**  
 Right-of-Way Configuration  
 (Clearbrook, MN to Superior, WI)

DATE: 8/9/2006

REVISED: 1/20/09

SCALE: NTS

DRAWN BY: MHN6795

K:\335\MN\_EMP\FIGURE32B.VSD



*This page left intentionally blank.*

## **APPENDIX C2**

### **Wisconsin Environmental Mitigation Plan**

*This page left intentionally blank.*



**Enbridge Energy, Limited Partnership  
Enbridge Pipelines (Southern Lights) L.L.C.**

**Alberta Clipper and  
Southern Lights Diluent  
Pipeline Projects**

# **Wisconsin Environmental Mitigation Plan**

**March 20, 2009**

ISSUED FOR PERMITTING

**ENBRIDGE ENERGY, LIMITED PARTNERSHIP  
ENBRIDGE PIPELINES (SOUTHERN LIGHTS) L.L.C.**

**ENVIRONMENTAL MITIGATION PLAN  
ALBERTA CLIPPER AND SOUTHERN LIGHTS DILUENT PROJECTS**

**TABLE OF CONTENTS**

INTRODUCTION .....	6
1.0 GENERAL MITIGATION MEASURES .....	8
1.1 CONSTRUCTION EQUIPMENT EMISSIONS .....	8
1.2 TEMPORARY EROSION AND SEDIMENT CONTROLS .....	8
1.3 RIGHT-OF-WAY ACCESS .....	8
1.4 ROAD REPAIR.....	9
1.5 RIGHT-OF-WAY REQUIREMENTS.....	9
1.6 LINE LIST AND PERMITS .....	10
1.7 UPLAND CLEARING .....	10
1.7.1 Disposal of Non-Merchantable Timber.....	10
1.7.2 Disposal of Merchantable Timber.....	11
1.7.3 Upland Grading and Stump Removal.....	11
1.7.4 Fencing.....	11
1.7.5 Trees and Shelterbelts .....	11
1.7.6 Irrigation Systems.....	11
1.7.7 Drain Tile Inlets .....	11
1.7.8 Upland Topsoil Segregation .....	12
1.7.9 Temporary Erosion and Sediment Controls .....	12
1.7.10 Temporary Slope Breakers.....	14
1.7.11 Noise and Dust Control .....	14
1.8 PIPE DELIVERY, BENDING & WELDING .....	15
1.9 UPLAND TRENCHING .....	15
1.9.1 Timing.....	15
1.9.2 Pipeline Depth .....	15
1.10 PIPE INSTALLATION.....	15
1.11 TRENCH BREAKERS .....	16
1.12 DRAIN TILE REPAIR .....	16
1.13 UPLAND BACKFILLING .....	16
1.14 WET WEATHER SHUTDOWN .....	16
1.15 CONTROLLING SPREAD OF UNDESIRABLE SPECIES.....	17
1.16 CLEANUP AND ROUGH/FINAL GRADING.....	17
1.17 TIMING.....	17

1.18	PERMANENT EROSION AND SEDIMENT CONTROLS .....	18
1.19	SOIL COMPACTION TREATMENT .....	18
1.20	STONE REMOVAL .....	18
1.21	OFF-ROAD VEHICLE CONTROL MEASURES.....	19
1.22	REPAIR OF DAMAGED CONSERVATION PRACTICES.....	19
1.23	LAND LEVELING FOLLOWING CONSTRUCTION.....	19
2.0	STREAM AND RIVER CROSSING GENERAL REQUIREMENTS .....	20
2.1	TIME WINDOW FOR CONSTRUCTION.....	20
2.2	PRE-CONSTRUCTION CONSIDERATIONS.....	20
2.2.1	Equipment Decontamination.....	20
2.2.2	Hazardous Materials.....	21
2.2.3	Refueling/Equipment Care.....	21
2.2.4	Alignment of Crossing.....	21
2.3	CLEARING AND GRADING.....	21
2.4	EXTRA WORKSPACE .....	21
2.5	BRIDGES .....	22
2.5.1	Types of Bridges.....	22
2.5.2	Bridge Design and Maintenance.....	22
2.6	STREAM AND RIVER CROSSING CONSTRUCTION METHODS.....	22
2.6.1	Wet Trench Method .....	23
2.6.2	Dam and Pump Method.....	24
2.6.3	Flume Method.....	25
2.6.4	Directional Drill and/or Guided Bore Method .....	26
2.7	PERMANENT RESTORATION.....	27
3.0	WETLAND CROSSING GENERAL REQUIREMENTS .....	29
3.1	WETLAND ACCESS .....	29
3.2	SPILL PREVENTION .....	29
3.2.1	Storage of Fuels and Other Materials.....	29
3.2.2	Refueling, Fuel Handling, and Equipment Maintenance.....	29
3.3	CLEARING .....	30
3.4	GRADING IN A WETLAND .....	30
3.5	CONSTRUCTION MATTING .....	31
3.6	TRENCHING .....	31
3.6.1	Topsoil Segregation.....	31
3.6.2	Trench Breakers .....	31
3.7	PIPELINE INSTALLATION.....	32
3.7.1	Push/Pull Method.....	32
3.7.2	Temporary Erosion and Sediment Controls.....	32
3.7.3	Concrete Coating.....	32

3.8	BACKFILLING .....	32
3.9	ROUGH GRADING, CLEANUP, AND TEMPORARY RESTORATION ..	33
	3.9.1 Timing .....	33
	3.9.2 Temporary Stabilization .....	33
4.0	HIGHWAY, ROAD and RAIL CROSSINGS .....	34
4.1	ADDITIONAL WORKSPACE .....	34
4.2	MAINTENANCE .....	34
4.3	TEMPORARY EROSION AND SEDIMENT CONTROLS .....	34
5.0	CONSTRUCTION DEWATERING .....	35
5.1	TRENCH DEWATERING .....	35
	5.1.1 Regulatory Notification and Reporting .....	36
	5.1.2 Flow Measurement .....	36
	5.1.3 Water Sampling .....	36
5.2	HYDROSTATIC TEST DISCHARGES .....	36
	5.2.1 Refueling .....	37
	5.2.2 Permit Requirements .....	37
	5.2.3 Siting of Test Manifolds .....	37
	5.2.4 Water Sampling .....	37
	5.2.5 Best Management Practices .....	37
	5.2.6 Flow Measurement .....	38
6.0	WATER APPROPRIATION .....	39
6.1	GENERAL .....	39
6.2	WATER SOURCES .....	39
6.3	FLOW MEASUREMENT .....	39
6.4	WATER SAMPLING .....	39
6.5	REGULATORY NOTIFICATION AND REPORTING .....	39
7.0	REVEGETATION .....	40



## FIGURES<sup>1</sup>

Figure 1	Typical Construction Layout Topsoil Segregation Modified Ditch Plus Spoil Side - (Wisconsin only)
Figure 2A	Typical Right-of-Way Configuration – North of Existing Lines
Figure 2B	Typical Right-of-Way Configuration – South of Existing Lines
Figure 3	Typical Topsoil Segregation – Trench Line Only – (Wisconsin Only)
Figure 4	Typical Temporary or Permanent Berms – Perspective View
Figure 5	Typical Temporary or Permanent Berms – Elevation View
Figure 6	Typical Silt Fence Installation
Figure 7	Typical Straw Bale Installation
Figure 8	Typical Trench Breakers – Perspective View
Figure 9	Typical Trench Breakers – Plan and Profile Views
Figure 10	Permanent Slope Breakers – Perspective View
Figure 11	Erosion Control Blanket – Steep Slopes ( $\geq 30\%$ )
Figure 12	Typical Waterbody Crossing – Open Cut – Wet Trench Method - (Wisconsin Only)
Figure 13	Typical Waterbody Crossing – Dam and Pump Method- (Wisconsin Only)
Figure 14	Typical Waterbody Crossing – Flume Method- (Clearbrook, MN to Superior, WI)
Figure 15	Typical Waterbody Crossing – Directional Drill Method
Figure 16	Typical Span Type Bridge With or Without Support (Timber Mat Bridge)
Figure 17	Typical Dewatering Measures
Figure 18	Typical Straw Bale Dewatering Structure
Figure 19	Typical Final Stream Bank Stabilization – Rip Rap & Erosion Control
Figure 20	Typical Wetland Crossing Method – (Wisconsin Only)
Figure 21	Typical Improved Road Crossing–Directional Bore Method – (Wisconsin Only)
Figure 22	Summer Saturated Wetland Construction ROW Southern Lights Construction
Figure 23	Summer Saturated Wetland Construction ROW Alberta Clipper Construction

---

<sup>1</sup> Site-specific plans supersede any design presented in the typical details.

## INTRODUCTION

This Environmental Mitigation Plan (EMP) outlines construction-related environmental policies, procedures, and mitigation measures developed by Enbridge Energy, Limited Partnership and Enbridge Pipelines (Southern Lights) L.L.C. (Enbridge or Company) for the construction of the Alberta Clipper and Southern Lights Diluent Pipeline Projects. This EMP was developed based on Enbridge's experience implementing best management practices during construction. It is intended to meet or exceed applicable federal, state and local environmental protection and erosion control specifications and practices. The EMP is designed to address typical circumstances that may be encountered along the Enbridge Alberta Clipper and Southern Lights Diluent Projects. Project specific permit conditions and/or landowner agreements may supersede general practices described in this document. Project-specific procedures for the Alberta Clipper and Southern Lights Diluent Projects have been incorporated into the EMP. The measures described in the EMP are consistent with relevant portions of the *Wisconsin Technical Standards*.

This document includes the following sections:

- Section 1.0 of the EMP describes general mitigation measures, including soil erosion and sedimentation control procedures, to be implemented during upland construction and upland restoration;
- Section 2.0 discusses stream and river construction, crossing, and restoration;
- Section 3.0 describes practices for wetland construction, crossings, and restoration;
- Section 4.0 discusses highway, road, and rail crossings;
- Section 5.0 discusses construction dewatering;
- Section 6.0 outlines water appropriation practices;
- Section 7.0 addresses revegetation measures;

Alternative construction procedures implemented in lieu of this EMP must provide an equal or greater level of protection to the environment, and must be approved in writing by Enbridge. Modifications for the construction of dual pipelines are highlighted below in the appropriate sections.

Unless otherwise specified, the construction Contractor (Contractor) will be responsible for implementing the requirements of this EMP. Enbridge will make the requirements of the EMP and applicable environmental permits known to the Contractor. If the Contractor has questions concerning these environmental requirements, the Contractor will contact an Enbridge representative.

Enbridge will provide appropriate construction oversight to confirm Company and Contractor compliance with the measures of this EMP and requirements of applicable federal, state, and local permits. Enbridge's Environmental Inspectors (EIs) will assist the Contractor in interpreting and implementing the requirements of the EMP, and verify compliance with these procedures for the company. Enbridge employs experienced EIs to manage unforeseen situations that are not directly addressed by the project documents. Enbridge relies on the experience and judgment of the EIs through coordination and consultations with project management staff to address those unforeseen situations should they occur in the field. The EI

will be expected to use judgment in the field to interpret environmental conditions and requirements, but will not be authorized to make major modifications or changes without the prior written approval of Enbridge. The EI will have the authority to stop activities and order corrective mitigation for actions that are not in compliance with the measures in this EMP, Landowner agreements, or environmental permit requirements. The EI will maintain appropriate records to document compliance with these and other applicable environmental permit conditions.

Enbridge will also hire Independent Environmental Monitors (Monitors or IEMs), approved by Enbridge and the applicable state agencies, to document compliance with permits and plans. Monitors will work collaboratively with Enbridge's environmental and agricultural inspection team to achieve compliance as well as work in an auditing role to assess the success of Enbridge's compliance program. Environmental Monitors will be responsible for monitoring Enbridge's compliance with permits issued by the applicable state and federal agencies. Monitors will communicate through daily reports submitted to the applicable state agencies and Enbridge, as well as through daily communication with Enbridge's EIs Team. Monitors will communicate directly with their respective agency contacts and with Enbridge's Environmental Inspectors, but will not communicate directly with the Contractor or sub-Contractor unless an Enbridge EI is present. Monitors will not have the authority to direct construction team activities, and will work through Enbridge's Environmental Inspection Team, if compliance issues are identified.

Enbridge has prepared this Wisconsin Environmental Mitigation Plan (WI EMP or EMP) for use in the construction and restoration of the Albert Clipper and Southern Lights Diluent Pipeline Projects (hereby referred to as the Project)

## **1.0 GENERAL MITIGATION MEASURES**

### **1.1 CONSTRUCTION EQUIPMENT EMISSIONS**

In an effort to reduce emissions of criteria and hazardous air pollutants associated with the operation of construction equipment, Enbridge will require that construction equipment working on the project be maintained in accordance with the manufactures specifications. In addition, Enbridge will encourage its contractors to:

- Ensure that diesel-powered equipment is properly maintained and shut off when not in use;
- Prohibit engine tampering to increase horsepower;
- Where practicable, operate equipment as far as possible from residential areas and sensitive receptors (schools, daycare centers, and hospitals);
- Use ultra low sulfur diesel fuel for their equipment if it is available for purchase within a reasonable distance to the construction spreads;
- Minimize to the extent practicable, construction-related trips of workers and equipment; and,
- Where practicable, use 1996 or newer model year equipment and vehicles.

Furthermore, Enbridge will require that Enbridge company-owned or leased vehicles working on the project be properly maintained and shut off when not in use. For diesel-powered Enbridge owned or leased equipment, Enbridge will:

- Prohibit engine tampering to increase horsepower;
- Use ultra low sulfur diesel fuel for vehicles if it is available for purchase within a reasonable distance to the construction spreads;
- Minimize to the extent practicable, construction-related trips; and,
- Where practicable, use 1996 or newer model year vehicles.

### **1.2 TEMPORARY EROSION AND SEDIMENT CONTROLS**

Temporary erosion and sediment controls (ECDs) include but are not limited to slope breakers, sediment barriers, stormwater diversions, trench breakers, mulch and revegetation. The goal of ECDs is to minimize erosion onsite, and prevent construction-related sediment from migrating offsite into sensitive resource areas such as streams, wetlands, lakes, or drainage ditches (dry or flowing). The Contractor will, at all times, maintain erosion and sediment control structures as required in the project construction documents and as required by all applicable permits. Non-functional erosion and sediment control features must be repaired, replaced, or supplemented within 24 hours after discovery, or as soon as field conditions allow the features to be repaired.

ECDs will be installed after initial clearing but before disturbance of the soil and will be replaced by permanent erosion controls as restoration is complete. Additional information on ECDs is provided in the upland, waterbody and wetland sections.

### **1.3 RIGHT-OF-WAY ACCESS**

Access to the right-of-way (ROW) will be from public roadways and Enbridge-approved private access roads only. Enbridge is responsible for creating signs or other methods to identify approved access roads in the field and to ensure that access is confined to only the approved roads. Vehicle tracking of soil from the construction site will be minimized by installation of Best Management Practices (BMPs) such as stone pads, timber mats, or equivalent. Soil tracked onto public roads will be removed.

## 1.4 ROAD REPAIR

The Contractor will repair private roads, lanes, and public roads damaged when moving equipment or obtaining access to the ROW.

## 1.5 RIGHT-OF-WAY REQUIREMENTS

All construction equipment and vehicles will be confined to the approved ROW and extra workspace. Although ROW requirements may vary between projects, construction activities for the Alberta Clipper and Southern Lights Diluent Projects will generally use a ROW as shown in Figures 1, 2A, and 2B. These drawings illustrate the Typical Construction Layout and ROW Configurations for the projects. The construction ROW configurations may be modified to avoid and/or minimize disturbance to sensitive resource areas such as wetlands and waterways.

Prior to commencement of clearing operations, the outer limits of the construction ROW and extra workspace areas will be marked with distinctive stakes and flagging by Enbridge. Construction activities will be restricted to the approved designated areas. Other areas (pipe storage and contractor yards, borrow and disposal areas, access roads, etc.) will be posted for use by the Contractor during construction activities.

The construction ROW (construction workspace) for the Alberta Clipper and Southern Lights Diluent Projects will include a portion of Enbridge's existing corridor, new permanent corridor permitted temporary workspace, and site-specific extra workspaces as defined below and shown in figures 2A, and 2B. Typically the construction ROW will be 140-feet-wide. The construction ROW width will be reduced to 125-feet-wide in selected locations (e.g., wetlands, waterbodies,) in accordance with applicable permit conditions, as indicated on the project construction alignment sheets and in the field by the use of staking.

### (a) ROW (Permanent)

Enbridge's existing permanently maintained corridor is generally 125 feet wide. Enbridge will be adding up to an additional 50 feet of permanently maintained corridor, depending on the location of the new pipelines in relation to the existing pipelines (refer to Figures 2A and 2B). The ROW is maintained to facilitate access and aerial inspection of the pipeline system.

### (b) Temporary Workspace

In addition to the ROW/permanent corridor, construction will require Temporary Workspaces (TWS). The TWS will be located adjacent to and contiguous with the proposed ROW/permanent corridor and will be identified on the construction alignment sheets and by distinctive staking of construction limits prior to clearing.

### (c) Extra Workspace

Site-specific extra workspace (EWS) locations, (construction work areas beyond the permanent corridor and TWS previously described), will be required at select locations such as steep slopes, road, waterbody, railroad, some wetland crossings, and where it is necessary to cross under the existing pipelines or foreign utilities. EWS will typically be located in uplands adjacent to the construction ROW and set 50-feet back from sensitive resource boundaries where site-specific field conditions allow. However, to complete work safely, Enbridge may need to locate EWS within a wetland or within the 50-foot

setback from a wetland or waterbody based on site-specific conditions. EWS adjacent to waterbodies and/or wetlands is addressed further in Sections 2.4 and 3.3, respectively.

Enbridge will acquire EWS from the landowner where necessary; use of unauthorized workspace is prohibited without Enbridge's approval. In all cases, the size of EWS will be kept to the minimum necessary to safely conduct work. Enbridge has conducted a preconstruction review of the entire project area to determine specific EWS locations. All approved EWS locations are depicted on the construction alignment sheets.

## **1.6 LINE LIST AND PERMITS**

Enbridge will provide the Contractor with a Construction Line List (CLL) that describes special requirements (e.g., timber salvage, topsoil segregation, restoration measures, fencing requirements, etc.) as agreed upon with Landowners. The Contractor must comply with these special requirements and/or permit conditions.

The CLL reflects requirements and comments provided by Landowners; however it is not a comprehensive list of construction requirements. The CLL must be considered in conjunction with other project documents and permits. Any third party agreements between the Contractor and the landowner must be pre-approved by Enbridge and in writing.

Unless otherwise noted within this EMP, Enbridge will obtain the necessary permits for the installation of the pipeline. Permit requirements may be more stringent than the requirements of this EMP. In all cases the more restrictive requirements will apply.

## **1.7 UPLAND CLEARING**

The initial stage of construction involves the clearing of brush, trees, and tall herbaceous vegetation from the ROW. Clearing may be accomplished with chain saws, mowers, and hydraulic tree-cutting equipment.

### **1.7.1 Disposal of Non-Merchantable Timber**

Unless otherwise directed by Enbridge, non-merchantable timber and slash will be disposed of by mowing, chipping, grinding, and/or hauling off site to an approved disposal facility or used in stabilizing erodible slopes or construction entrances. In non-agricultural, non-wetland areas, chips may be uniformly broadcast (less than 1 inch thickness) across the ROW where they would ultimately be incorporated into the topsoil layer during grading activities, with landowner approval. Burning of non-merchantable wood may be allowed only where the Contractor has acquired all applicable permits and approvals (e.g. agency and landowner) and in accordance with all state and local regulations. The Contractor must provide Enbridge with copies of these permits and/or approvals prior to initiating burning.

Burning will not be allowed in a wetland. Burning is also not allowed within 100 feet of a wetland or waterbody without site specific approval from Enbridge. No chips, mulch, or mechanically cut woody debris will be stockpiled in a wetland and no upland woody debris will be disposed of in a wetland (see section 3.3 for further information on clearing in a wetland). Non-merchantable timber may not be disposed of by placing it off the ROW. No woody debris disposal will be allowed in agricultural areas or wetlands.

### **1.7.2 Disposal of Merchantable Timber**

All merchantable timber will be the property of the Company and the Contractor will be responsible for merchandising timber. If a commercial buyer cannot be found, the timber may be considered non-merchantable and disposed of as referenced in Disposal of Non-Merchantable Timber (section 1.7.1).

### **1.7.3 Upland Grading and Stump Removal**

Grading generally follows clearing and involves leveling and smoothing the construction ROW, including TWS, and EWS areas as necessary, to create a safe, even working surface for equipment and vehicles. To facilitate proper cleanup and restoration in upland areas, tree stumps outside the ditch line will be ground no less than four-inches below normal ground surface or completely removed and hauled off to an approved disposal facility. Stumps in the ditch line will be completely removed, ground, and/or hauled off to an approved disposal facility. Topsoil and subsoil disturbed during grading operations will not be mixed with foreign material (e.g., stumps and brush).

### **1.7.4 Fencing**

Before or during clearing of the ROW, existing fences and livestock barriers will be cut as necessary to access the ROW. Existing fencing will be H-Braced and secured prior to cutting to prevent the slacking of wires. Temporary gates and/or fencing will be installed where necessary to maintain existing access restrictions, contain livestock and protect sensitive areas. These temporary measures will remain in place until construction is completed and permanent repairs or new fencing can be installed.

### **1.7.5 Trees and Shelterbelts**

Care will be taken to minimize tree removal. To the extent practicable, and in accordance with applicable permits, wind breaks and shelterbelts will be crossed by minimizing the width of the ROW. When clearing, trees will be felled onto the ROW to minimize damage to off-ROW vegetation.

### **1.7.6 Irrigation Systems**

If pipeline construction activities interfere with the operation of spray irrigation systems, Enbridge will establish with the landowner or Tenant, an acceptable amount of time the irrigation system may be out of service. If feasible, temporary measures will be implemented to allow an irrigation system to continue to operate across the ROW during pipeline construction. Any damage to irrigation systems caused by construction-related activities will be repaired following backfilling.

### **1.7.7 Drain Tile Inlets**

Enbridge will attempt to locate existing drain tile inlets that are located near the construction work area prior to construction. Drain tile inlets will be marked using flags. Located drain tile inlets with the potential to receive stormwater from the construction project will be protected by using the appropriate ECDs until sources with the potential to discharge has been stabilized. The determination of the specific ECD will be made based on the location of an inlet with respect to the project area, drainage area from the construction work area to the inlet, topography, vegetation, soils, and accessibility to the inlet. Where drain tile inlets are located off of Enbridge's ROW, Enbridge may not have authorization to install ECDs at the inlet site. In

these cases, sediment control measures (typically silt fence) will be installed along the edge of the construction work area that drains to the inlet structure to minimize sediment.

### **1.7.8 Upland Topsoil Segregation**

Topsoil generally has physical and chemical properties that are conducive to good plant growth. To prevent the mixing of topsoil with less productive subsoil during construction, topsoil will be segregated in selected areas where soil productivity is an important consideration. A minimum one foot of separation must be maintained between the topsoil and subsoil piles to prevent mixing. Where the one foot separation cannot be maintained, a physical barrier, such as a thick layer of straw mulch, may be used between the spoil and topsoil piles to prevent mixing. Use of the physical barrier must be reviewed and approved by Enbridge on a site-specific basis. Upland areas where topsoil will be stripped include cropland, hay fields, pasture, residential areas and other areas as requested by the landowner. Topsoil will not be used to construct trench breakers (see section 1.11) or to pad the pipe. Gaps must be left and ECDs installed where stockpiled topsoil and spoil piles intersect with water conveyances (i.e., ditches, swales, and waterways) to maintain natural drainage.

#### **Topsoil Segregation Methods**

The following topsoil segregation methods may be employed during construction:

- Modified Ditch-Plus-Spoil Side (refer to Figure 1)
- Trench-Line-Only (refer to Figure 3 )

A Modified Ditch-Plus-Spoil topsoil segregation technique will typically be used in active cropland, which will consist of stripping topsoil from the spoil storage area, ditch line, and the primary travel lane. Alternative topsoil segregation methods may be used on a site-specific basis or as requested by the landowner. The Trench-Line-Only topsoil segregation method may be used where Enbridge determines that the width of the construction ROW is insufficient for other methods to be used. Enbridge may also use the Trench-Line-Only topsoil segregation method in areas where there is a thick sod layer such as in hay fields, pastures, golf courses, and residential areas, unless otherwise requested by the landowner.

Topsoil is not typically segregated in forested areas, standing water wetlands, and nonagricultural open areas. However, in areas of steep side slopes adjacent to wetlands and waterbodies, including forested areas, where subsoil will be excavated (e.g. two-toned, side-cut, etc.) to create a level workspace, topsoil will be segregated to the extent practicable and at the direction of Enbridge.

#### **Depth of Upland Topsoil Stripping**

Topsoil will be stripped to a maximum depth of 12 inches in cultivated lands, unless otherwise requested by the landowner. Additional space may be needed for spoil storage if more than 12 inches of topsoil are segregated. If less than 12 inches of topsoil are present, the Contractor shall attempt to segregate to the depth that is present.

### **1.7.9 Temporary Erosion and Sediment Controls**

ECDs are intended to slow the velocity of water off-site to minimize erosion, stop the movement of sediments off the construction ROW, and prevent the deposition of sediments into sensitive resources that may be on or adjacent to the ROW. ECDs typically used are silt fence and/or trenched-in and staked straw bales and other barriers such as compacted earth (e.g.,



drivable berms across travel ways), sand bags, or other appropriate materials. If temporary ECDs are removed during the day to allow equipment access, they must be reinstalled at the end of the day.

Temporary ECDs will be installed after clearing and prior to grubbing and grading activities at the base of sloped approaches to streams, wetlands, and roads. Temporary ECDs will also be installed at the edge of the ROW as needed, and/or in other areas determined by the EI to slow water leaving the site and prevent siltation of waterbodies and wetlands downslope or outside of the construction ROW (e.g., swales and side slopes). Temporary ECDs will be placed across the entire construction ROW at the base of slopes greater than 5 percent where the base of the slope is less than 50 feet from tile line inlets, drainage ways, wetlands and/or waterbodies until the area is revegetated and there is no potential scouring or sediment transport to surface waters.

If silt fence is in use, when the depth of sediment reaches about one-third of the height, the sediment will be removed. Non-functional ECDs will be repaired, replaced, or supplemented with functional structures within 24 hours after discovery, or as soon as field conditions allow the features to be repaired.

Temporary ECDs installed across the travel lane may be removed during active daytime construction; however, ECDs must be reinstalled after equipment passage or activities in the area are completed for the day. These ECDs must also be repaired and/or replaced prior to forecasted inclement weather. The Contractor is responsible for monitoring weather conditions and adjusting resources as needed to address pending and/or existing weather conditions.

### **Temporary Stabilization**

Installation of temporary seeding, mulch, and erosion control mats may be necessary in certain locations if there are construction delays within a spread of at least 14 days. The Contractor may be required by Enbridge to install temporary stabilization materials sooner based on site conditions, or as required in Enbridge's WPDES permit. Temporary stabilization measures as outlined in Enbridge's Wisconsin Revegetation and Restoration Monitoring Plan will be implemented to minimize erosion and for sediment control.

Enbridge will install the appropriate class of erosion control blanket on slopes greater than 5 percent that would be exposed over the winter and drain to surface waters. Enbridge will attempt to install erosion control blankets on the exposed slopes prior to snowfall; however, construction progress and/or seasonal weather variations may prevent installation prior to the first snowfall. Installation of erosion control blankets and additional BMPs, as applicable based on site conditions, would continue after the first snowfall to protect slopes prior to spring melt and runoff.

### **Mulch**

Mulch will be applied as indicated in Enbridge's Revegetation and Restoration Monitoring Plan. If exposed soils have not been stabilized prior to freezing of the ground, and soil conditions are such that disking is still effective, crimp in straw mulch to help stabilize these areas, but on steeper slopes blanket is still preferable.

### 1.7.10 Temporary Slope Breakers

Temporary slope breakers will to be installed to minimize concentrated or sheet flow runoff in disturbed areas in accordance with the following maximum allowable spacing unless otherwise specified in permit conditions.

<u>Slope (%)</u>	<u>Approximate Spacing (ft)</u>
3-5	250
5-15	200
15-25	150
>25	<100

If the length of the slope is less than the distance of the required spacing, slope breakers are not required unless a sensitive resource area (e.g., wetland) is located immediately down slope, or as requested by the EI. Temporary slope breakers may be constructed using earthen subsoil material, silt fence, hay bales or in non-agricultural land rocked trenches may be used. On highly erodible slopes, slope breakers in the form of either earthen berms or rocked trenches will be used whenever possible.

Temporary slope breakers will be constructed according to the following specifications:

- earthen berms will be installed with a 2 to 4 percent out slope, with a minimum 4 foot base and a minimum height of 1.5 feet (see Figures 4 and 5);
- hay bales used as slope breakers will be trenched in and staked so as to not allow spacing between bales or allow flow underneath the bales;
- the outfall of temporary slope breakers will be directed off the construction ROW into a stable well-vegetated upland area or into an appropriate energy-dissipating sediment control device (e.g., silt fence, straw bales, rock aprons) to prevent the discharge of sediments (see Figures 4 and 5);
- proper slope breaker outfalls will be established where topsoil segregation and/or grading has created a barrier at the edge of the construction workspace;
- gaps will be created through spoil piles where necessary to allow proper out letting of temporary berms;
- temporary slope breakers will be inspected daily and repaired as necessary, but no more than 24 hours after discovery or as soon as access allows, to maintain operational integrity and prevent erosion in active construction areas.

### 1.7.11 Noise and Dust Control

The Contractor will take all reasonable steps to control construction-related noise and dust near residential areas and other areas as directed by Enbridge. Control practices may include wetting the ROW and access roads, limiting working hours in residential areas, reestablishment of vegetation and/or additional measures as appropriate based on site-specific conditions.

## **1.8 PIPE DELIVERY, BENDING & WELDING**

Typically, individual joints of pipe will be strung along the construction ROW before excavating the pipeline trench. This operation involves specially designed equipment to deliver pipe from pipe storage yards to the ROW.

After pipe stringing is complete, the pipe will be bent, as necessary, to conform to changes in ground contours and pipeline alignment. Individual pipe joints will be welded together and the welds will be radiographically inspected. The welds will then be coated to protect them from corrosion.

## **1.9 UPLAND TRENCHING**

Trenching in uplands consists of excavating the trench for the pipeline, and is typically accomplished with a backhoe excavator or a rotary wheel ditching machine. Excavated material will be sidecast (stockpiled) within the approved construction ROW separate from topsoil (see section 1.7.8), and stored such that the area subject to erosion is minimized. Enbridge will coordinate with Landowners to minimize disruption of access caused by the trench during construction. Where deemed appropriate by the Company, Enbridge will leave plugs of soil in the ditch or will construct temporary access bridges across the trench for the landowner to move livestock or equipment. Trenches will also be sloped where started and ended to allow ramps for wildlife to escape.

### **1.9.1 Timing**

The length of time a trench is left open will be minimized to ensure that installation of the pipe and restoration of the ROW occurs in a timely fashion. Enbridge will limit the amount of excavated open trench to 2 days of anticipated welding production or approximately 14,000 feet per spread, per pipe. Site specific activities such as HDDs, guided bores, road bores, tie-in points, and valve work may be performed independent of a spread. Each spread will be fully equipped and staffed to operate independently of one another.

### **1.9.2 Pipeline Depth**

At a minimum, the pipeline will be buried in accordance with U.S. Department of Transportation regulations (40 CFR Part 195), which stipulate a minimum of three (3) feet of top cover for normal excavations, and 18 to 30 inches of cover for rock excavations (depending on the location), to prevent damage to the pipeline from normal use of the land.

For the Alberta Clipper and Southern Lights Diluent Projects, the depth of cover will vary from 36 inches to 60 inches, depending on state law, permit requirements, landowner agreements, and site-specific conditions (e.g., depth of drain tile). If a state-level agency specifies a more stringent requirement for pipeline depth than the DOT and/or landowner requirements, the Company may request a waiver of that requirement. Increased pipeline depth will result in greater amounts of ditch spoil and, consequently, may require additional temporary workspace for storage of the spoil.

## **1.10 PIPE INSTALLATION**

Once the trench has been inspected for proper depth, rocks, or other obstructions, the welded pipe is lowered into the trench. In rocky soils, the pipe may be wrapped with a protective shielding if necessary to prevent damage to the pipe coating during backfilling.

## 1.11 TRENCH BREAKERS

Trench breakers will be installed as deemed necessary by Enbridge in sloped areas after the pipe has been lowered into the trench. Trench breakers protect against subsurface water flow along the pipe after the trench is backfilled. Trench breakers will be constructed with bags filled with rock-free subsoil or sand. They will be placed from the bottom of the trench to near the top of the trench, completely surrounding the pipe and must be properly keyed into the undisturbed trench walls (see Figures 8 and 9). The location for trench breakers will be based on field conditions including the degree and length of slope, presence of down slope sensitive resource areas such as wetland and waterbodies, and proximity to other features such as roads and/or railroads. The following conditions apply to the placement and installation of trench breakers unless otherwise directed by Enbridge:

- Trench breakers will be spaced as described for permanent berms (see section 1.7.10) or as otherwise specified by Enbridge.
- Trench breakers will be installed on slopes greater than 5 percent adjacent to streams, wetlands, or other waterbodies.
- Topsoil will not be used to construct trench breakers.
- Where the pipeline exits a wetland towards areas of lower relief, trench breakers will be installed where there is a potential for underground drainage along the pipe in order to prevent wetland or waterbody drainage

The actual location of each trench breaker will be selected through coordination between Enbridge's EIs, Enbridge's Craft Inspectors, and the Contractor's Foreman for backfilling activities.

## 1.12 DRAIN TILE REPAIR

Where drain tiles are cut during trenching, the locations will be flagged by the Contractor and the Contractor will notify the EI and/or Agricultural Inspector of the locations. The Contractor will probe each drain tile line that is crossed by the trench using a sewer rod or pipe snake (or equivalent), prior to backfilling, to determine if the tile lines were damaged during construction. Drain tiles damaged during construction will be repaired to their preconstruction condition or better. Additional information is provided in Enbridge's Agricultural Mitigation Plan (AMP).

## 1.13 UPLAND BACKFILLING

Backfilling follows pipe installation and consists of replacing the material excavated from the trench. In areas where topsoil has been segregated, the subsoil will be replaced first, and the topsoil will be spread uniformly over the area from which it was removed. Prior to backfilling, the trench shall be dewatered in accordance with the methods discussed in WI EMP section 5.1.

## 1.14 WET WEATHER SHUTDOWN

During construction, certain activities may be suspended in wet soil conditions, based on consideration of the following factors:

- plasticity of the surface soil to a depth of approximately 4 to 8 inches;

- extent of surface ponding;
- extent and depth of rutting and mixing of soil horizons;
- areal extent and location of potential rutting and compaction (i.e., can traffic be rerouted around wet area); and
- type of equipment and nature of the construction operations proposed for that day.

Additional requirements for working in agricultural land during wet conditions are included in Enbridge's AMP.

If the above factors cannot be achieved to the satisfaction of Enbridge, the Contractor will cease work in the applicable area until Enbridge determines that site conditions are such that work may continue.

The Contractor is responsible for appropriately planning for work, considering for the potential for wet conditions, and being prepared to implement mitigative measures in the event of wet weather conditions. This is particularly important when conducting work in unsaturated wetlands. The Contractor is responsible for implementing any and all such corrective measures should conditions subsequently worsen where the above described criteria cannot be met.

### **1.15 CONTROLLING SPREAD OF UNDESIRABLE SPECIES**

It is Enbridge's intent to minimize the potential introduction and/or spread of undesirable species (i.e., invasive species and noxious weeds) along its ROW due to pipeline construction activities. However, it is not practicable for Enbridge to eradicate undesirable species that area adjacent to its ROW. Enbridge will minimize the potential for the establishment of undesirable species by minimizing the time duration between final grading and permanent seeding. Enbridge will also require that construction equipment be cleaned before arriving on site to prevent the introduction of undesirable species to the project area. A more detailed discussion of controls for noxious weeds is provided in Enbridge's Noxious Weed Plan.

### **1.16 CLEANUP AND ROUGH/FINAL GRADING**

Initial cleanup and rough grading activities may take place simultaneously. Cleanup involves removing construction debris (including litter generated by construction crews and excess rock). Rough and final grading includes restoring disturbed areas as near as practicable to preconstruction conditions, returning the topsoil where topsoil has been stripped, preparing a seedbed (where applicable) for permanent seeding, installing or repairing temporary erosion control measures, repairing/replacing fences, and installing permanent erosion controls

### **1.17 TIMING**

The Contractor shall begin cleanup and rough grading (including installation of temporary erosion and sediment control measures) within 72 hours after backfilling. The Contractor shall attempt to complete this cleanup within one week, weather and soil conditions permitting.

Where two pipelines (Alberta Clipper and Southern Lights Diluent) are being installed, timing of cleanup and rough grade will be applicable after the installation of the second pipeline.

## 1.18 PERMANENT EROSION AND SEDIMENT CONTROLS

During final grading, slopes in areas other than cropland will be stabilized with erosion control structures (see Figure 10). Erosion control treatments of specific physical land features are described below.

### Slopes

Permanent berms (diversion dikes or slope breakers) will be installed on all slopes, according to the following maximum spacing requirements unless otherwise specified in permit conditions:

<u>Slope (%)</u>	<u>Approximate Spacing (ft)</u>
3-5	250
5-15	200
15-25	150
>25	<100

Permanent berms will be constructed according to the following specifications:

- Permanent berms will be installed with a 2 to 4 percent outslope.
- Permanent berms will be constructed of compacted earth.
- The outfall of berms will be directed toward appropriate energy-dissipating devices, and off the construction ROW if possible
- Permanent berms will be inspected and repaired as deemed necessary by Enbridge to maintain function and prevent erosion. Figures 6 and 7 illustrate berm specifications.
- Erosion control blankets (curlex, jute, or equivalent) will be placed on slopes over 30 percent (see Figure 11) or that are a continuous slope to a sensitive resource area (e.g., wetland or waterway).

## 1.19 SOIL COMPACTION TREATMENT

Cultivated fields and compacted or rutted areas will be tilled with a deep tillage device or chisel plowed to loosen compacted soils. If subsequent construction and cleanup activities result in further compaction, additional measures will be undertaken to alleviate the soil compaction. Additional information on soil compaction is provided in Enbridge's AMP.

## 1.20 STONE REMOVAL

A diligent effort will be made to remove excess stones larger than four inches in diameter from the upper 8 inches of soil or as specified in permit conditions or landowner agreements. Stone removal efforts will cease when the size and density of stones on the ROW are similar to undisturbed areas adjacent to the ROW. Excess rock will be piled in upland areas where landowner permission has been obtained, or will be hauled off-site to an Enbridge approved disposal site. Additional information on soil compaction is provided in Enbridge's AMP.

### **1.21 OFF-ROAD VEHICLE CONTROL MEASURES**

Off-road vehicle control measures will be installed as requested by Landowners or as directed by land management agencies at points of entry. Such measures may include installing fences and gates, or placement of other barriers such as boulders or timbers. Visual screening may also be installed to deter use of the pipeline corridor from unauthorized activities, if requested by the landowner. No Trespassing signs will be installed at aboveground facilities, according to the provisions of M.S. 609.6055 (Trespass on Critical Public Service Facility; Utility; or Pipeline) to provide clear notice to the public and protect the integrity of the pipeline. All fences and gates removed or damaged will be repaired or replaced.

### **1.22 REPAIR OF DAMAGED CONSERVATION PRACTICES**

All soil conservation practices (such as terraces, grassed waterways, etc.) that are damaged by the pipeline construction will be restored to preconstruction conditions to the extent practicable.

### **1.23 LAND LEVELING FOLLOWING CONSTRUCTION**

Following the completion of the pipeline, the ROW will be restored to its pre-construction conditions as practical. Should uneven settling or documented surface drainage problems occur following the completion of pipeline construction, Enbridge will take appropriate steps to remedy the issue.

Permanent soil erosion and sediment control will begin as soon as soil conditions permit seed bed preparation and seed germination. Actively cultivated lands will be restored but will not be reseeded unless requested by the landowner.

## **2.0 STREAM AND RIVER CROSSING GENERAL REQUIREMENTS**

Pre-construction planning is an essential part of stream crossings. Stream crossing requirements, including construction methods, timing, erosion control, and restoration are described in this section and in the stream crossing permits issued by state and federal agencies. If the Contractor considers certain parts of these procedures to be technically impractical due to site-specific engineering constraints, the Contractor may seek modifications through the Variance Request Process. The Variance Request Process will be developed in conjunction with state regulatory agencies and will be provided in Enbridge's Construction Environmental Control Plans (CECP). Prior to construction, the Contractor must identify alternative provisions that would provide an equal or greater level of protection to stream and river ecosystems. Enbridge will review the Contractor's alternatives and consult with appropriate regulatory agencies. The Contractor must receive written approval from Enbridge prior to implementing the alternatives. The EI will confer with the IEM during wet and high runoff conditions to determine whether conditions warrant additional considerations for construction activities.

The procedures in this section apply to streams, rivers, and other waterbodies such as jurisdictional ditches, ponds, and lakes. These procedures require that judgment be applied in the field and will be implemented under the supervision of Enbridge. The intent of the mitigation procedures is to minimize construction-related disturbance to streams and waterbodies by limiting the duration of construction in these areas and by minimizing erosion and sedimentation.

### **2.1 TIME WINDOW FOR CONSTRUCTION**

In-stream trenching will be conducted during periods permitted by the appropriate regulatory agencies and applicable permits.

### **2.2 PRE-CONSTRUCTION CONSIDERATIONS**

#### **2.2.1 Equipment Decontamination**

The State of Wisconsin requires special decontamination provisions for equipment/materials to prevent the spread of invasive species and/or viruses from one waterbody to another. These special decontamination provisions apply to equipment/materials that will come into contact with the water including (but not limited to) excavation equipment, barges, boats, turbidity curtains, sheet piling, hoses, pumps, bridging materials, and culverts/flumes. The following decontamination procedures will be implemented where construction will occur in perennial waterbodies and within intermittent streams with water present at the time of construction:

1. Inspect and remove mud and vegetation debris (or similar) from all equipment that will be in contact with the water;
2. Drain all water from equipment, such as pumps and hoses; and,
3. Properly dispose of any debris removed from the equipment.

In addition to the decontamination methods listed above, the State requires at least one of the following methods also be implemented:

1. Steam cleaning (temperature not less than 212 degrees Fahrenheit) the portion of equipment that will come into contact with the water;



2. Washing equipment with soap and water or high pressure water of not less than 2,000 pounds per square inch pressure;
3. Allowing equipment to dry thoroughly for not less than five (5) days;
4. Disinfecting equipment with 200 parts per million (0.5 ounces per gallon) chlorine for not less than 10 minutes contact time; or,
5. Disinfecting with another State approved disinfectant.

### **2.2.2 Hazardous Materials**

Hazardous materials, chemicals, fuels, lubricating oils, will not be stored and/or concrete coating activities will not occur within 100 feet of streams and waterbodies without implementation of special provisions in accordance with Enbridge's Spill Prevention, Containment and Control Plan (Spill Plan).

### **2.2.3 Refueling/Equipment Care**

Construction equipment will be refueled at least 100 feet from streams and waterbodies. Where the Contractor and EI determines that conditions require construction equipment to be refueled within 100 feet of streams, the Contractor must follow the procedures described in Enbridge's Spill Plan and implement additional provisions based on site-specific conditions. No equipment will be washed within 100 feet of streams or waterbodies. Overnight parking of equipment is not allowed within 100 feet of a stream or waterbody unless special provisions have been implemented in accordance with Enbridge's Spill Plan. Maintenance (e.g., lubricating) of construction equipment will not be allowed within the 100 foot buffer zone without approval from the EI with additional special provisions for containment.

### **2.2.4 Alignment of Crossing**

Stream crossings will be designed as close to perpendicular to the axis of the stream channel as engineering and routing constraints allow, creating the shortest crossing length.

## **2.3 CLEARING AND GRADING**

The Contractor will leave a 20-foot buffer (from the ordinary high water mark (OHWM)) of undisturbed herbaceous vegetation on all stream banks during initial clearing, except where grading is needed for bridge installation, or where restricted by applicable regulations and/or permit conditions. In Wisconsin, the OHWM is defined as the point on the bank or shore up to which the presence and action of the water is so continuous as to leave a distinct mark either by erosion, destruction of terrestrial vegetation or other easily recognized characteristic.

Woody vegetation within this buffer may be cut and removed during clearing, leaving the stumps and root structure intact. Non-woody vegetation and the soil profile will be left intact until the Contractor is ready to begin trenching the stream crossing. The Contractor will properly install and maintain sediment control measures at the 20-foot buffer line adjacent to streams immediately after clearing and prior to initial ground disturbance (see Figures 12, 13, and 14). This buffer should not be confused with the 50-foot setback required for extra workspace (see section 2.4).

## **2.4 EXTRA WORKSPACE**

Extra workspaces, as defined in section 1.5, include work areas outside the boundary of the typical construction ROW. These spaces are typically used to assemble pipe segments and for temporary spoil storage. Clearing of forested and brushy areas for EWS will be avoided as much as possible. Woody vegetation in wetlands and riparian areas will typically not be cleared

for the purpose of EWS unless approved by appropriate regulatory agencies as stipulated in permits issued for the project. Extra workspaces will be constructed as follows:

- Extra workspaces will be located at least 50 feet away from the OHWM if topographic or other physical conditions such as stream channel meanders allow (see Figures 12, 13, and 14).
- If safe work practices or site conditions do not allow for a 50-foot setback, extra workspaces should be located no closer than 20 feet from the OHWM, subject to site-specific approval by Enbridge.
- Extra workspaces will be limited to the minimum size needed to construct the stream crossing.

## **2.5 BRIDGES**

Temporary equipment bridges will be used on most waterways (upon approval by the appropriate agency), including small waterways such as ditches and intermittent streams, where there is a potential for stormwater runoff or rain events to transport sediment downstream from equipment crossing the waterway. Bridges will be constructed as described below and will be removed as soon as possible during final restoration. Bridges will not typically be installed at directionally drilled waterbodies.

Bridges at jurisdictional waterbodies must be built and maintained in accordance with applicable permits. The special pre-installation equipment/materials decontamination provisions discussed in section 2.2.1 apply to installation of bridging material.

### **2.5.1 Types of Bridges**

Equipment bridges will be constructed using one of the following techniques:

- Timber mats (see Figure 16)
- Railroad flat cars
- Other methods as approved by Enbridge and appropriate agencies

### **2.5.2 Bridge Design and Maintenance**

Bridges at jurisdictional waterbodies must be built and maintained in accordance with applicable permits. Equipment bridges will be designed to withstand the maximum foreseeable flow of the stream, and will be securely anchored with cables or cable-like material. Bridges will not restrict flow or pool water while the bridge is in place, and will be constructed with clean materials. Bridges will be designed and maintained to prevent soil from entering the waterbody. Soil that accumulates on the bridge decking will be removed as needed, or as deemed necessary by the EI. Where both the Alberta Clipper and Southern Lights Diluent pipelines will be constructed, bridges should be placed to accommodate installation of both pipelines without relocation, where practicable.

## **2.6 STREAM AND RIVER CROSSING CONSTRUCTION METHODS**

The following stream and river crossing methods are typically used, subject to further restrictions by Enbridge and applicable permits and subject to modifications as approved by

appropriate regulatory agencies during construction. Only clearing equipment and equipment necessary to install equipment bridges will be allowed one opportunity to ford waters crossed by the project, unless otherwise restricted in applicable permits.

## 2.6.1 Wet Trench Method

### Installation

The wet trench method will be used to cross streams and rivers not permitted to be flumed, dam and pumped, or directionally drilled (see Figures 12, 13, 14, and 15). The following procedures will be used during wet trench crossings:

- Sediment control measures will be in place before grading from the 20-foot vegetative buffer left on each stream bank. Spoil containment structures will be installed back from the stream bank so that spoil does not migrate into the stream. Grading will be directed away from the waterbody to minimize the potential for sediment to enter the stream. Grading of stream banks will be restricted to the trench line and areas necessary for safe bridge installation.
- After grading, backhoes or draglines will be used to excavate the trench. Excavating equipment will operate from one or both banks, without entering the stream. If equipment must encroach into the stream, it will operate on clean construction mats. Streambed material will be segregated and placed within a spoil containment structure in approved construction work area limits.
- In-stream trenching and backfilling for each pipeline (separately) will typically be completed within 24 hours or less on minor waterbodies (<10 feet wide) and 48 hours or less on intermediate (>10 feet to 100 feet wide) or major waterbodies (>100 feet wide) (not including HDD crossings) or as directed by applicable permits.
- Earthen trench plugs (hard plugs) between the stream and the upland trench will be left undisturbed during excavation of the in-stream trench to prevent diversion of the stream flow into the open trench and to prevent water that may have accumulated in the adjacent upland trench from entering the waterbody. Trench plugs will be removed immediately prior to pipe placement, and then replaced when the pipe is in place. Trench water accumulated upslope of trench plugs must be dewatered appropriately prior to trench plug removal.
- If trench dewatering is necessary, the pump intake will be suspended off the trench bottom and dewatering will take place into a sediment filter bag and/or a straw bale dewatering structure (see Figures 17 and 18) where directed by Enbridge. The trench will be dewatered in such a manner that no heavily silt-laden water flows into streams or wetlands (see section 5.1). Only non-woven fabric will be used for filter bags.
- Backfilling will begin after the pipe is positioned in the trench at the desired depth. Backfill material will consist of the spoil material excavated from the trench and parent streambed unless otherwise specified in state or federal permits. The in-stream trench will be backfilled so that the stream bottom is as

near as practicable to its pre-construction condition, with no impediments to normal water flow.

### **Temporary Stabilization**

Enbridge will restore the stream banks as near as practicable to pre-construction conditions unless that slope is determined to be unstable (see section 2.7). Once the banks have been reshaped, ECDs will be installed within 24 hours of backfilling the crossing. Temporary slope breakers will be installed on all sloped approaches to streams in accordance with the spacing requirements outlined in Section 1.7.10.

A temporary seed mix (e.g., annual rye or annual oats) and mulch and/or erosion control blankets will be installed within a 50-foot buffer on either side of the stream. Silt fence will be installed upslope of the temporary seeding area.

## **2.6.2 Dam and Pump Method**

### **Installation**

The dam and pump method is a dry crossing method that is suitable for low flow streams and is a preferred alternative to fluming for crossing meandering channels. The dam and pump method involves damming of the stream with sandbags, inflatable dams, and/or steel plates upstream and downstream of the proposed trench before excavation (see Figures 13) and pumping water around the construction area. The following procedures will be used for dam and pump crossings:

- Pumping of the stream across the ROW will commence simultaneously with dam construction to prevent interruption of downstream flow. Stream flow will be pumped across the construction area through a hose and will be discharged to an energy-dissipation device, such as plywood boards, to prevent scouring of the stream bed.
- The pumps will be located on the upstream side of the crossing and will be placed in impermeable, sided structures which will act as containment units for the pumps and fuel containers. The pumps used for the Dam and Pump crossing method will not be placed directly in the stream or on the streambed. Pumps will have a capacity greater than the anticipated stream flow. The pumping operation will be staffed 24 hours a day and pumping will be monitored and adjusted as necessary to maintain an even flow of water across the work area and near-normal water levels upstream and downstream from the crossing. A backup pump of equal or greater capacity will be on-site at all times in the event that the primary pump fails.
- Spill kits will be stored adjacent to pumps and fuel.
- Dams will be constructed of sandbags, inflatable dams, aqua-dams, and/or steel plates. The dams will prevent the stream from flowing into the construction area. The dams will be continuously monitored for a proper seal. Additional sandbags, plastic sheeting, steel plating, or similar materials will be used where necessary to minimize the amount of water seeping around the dams and into the construction work area.

- Backhoes located on one or both stream banks will excavate a trench across the stream bed. Streambed material will be segregated and placed within a spoil containment structure in approved construction work area limits. Existing streambed material will be segregated and placed within a spoil containment structure in approved construction work area limits.
- Trench (earth) plugs between the stream and the upland trench will be used during excavation of the in-stream trench to prevent diversion of the seeped groundwater into the open trench. Trench plugs will be removed immediately before pipe placement, and then replaced when the pipe is in place.
- Standing water that is isolated in the construction area by the dams will be pumped into a sediment filter bag and/or a straw bale dewatering structure located in such a manner that no heavily silt-laden water flows into streams or wetlands (see Section 5.0). Only non-woven fabric will be used for filter bags.
- Backfilling will begin after the pipe is positioned in the trench to the desired depth. Backfill material will consist of the spoil material and parent streambed excavated from the trench unless otherwise specified in state or federal permits. The in-stream trench will be backfilled so that the stream bottom is similar to its pre-construction condition, with no impediments to normal water flow.

### **Temporary Stabilization**

Restoration of the ROW and the installation of temporary erosion controls will be similar to that described for the wet trench method above. Once the stream banks have been stabilized, the dams and pump will be removed.

### **2.6.3 Flume Method**

#### **Installation**

The flume method is a dry crossing method that is suitable for crossing sensitive, relatively narrow streams that have straight channels and are relatively free of large rocks and bedrock at the point of crossing. This method involves placement of flume pipe(s) in the stream bed to convey stream flow across the construction area without introducing sediment to the water (see Figures 14). The procedures for using the flume method are described below.

- The flume(s) will be of sufficient diameter to transport the maximum flows anticipated to be generated from the watershed. The flume(s), typically 40 to 60 feet in length, will be installed before trenching and will be aligned so as not to impound water upstream of the flume(s) or cause downstream bank erosion. The flumes will not be removed until after the pipeline has been installed, trench has been backfilled, and the stream banks have been stabilized.
- The upstream and downstream ends of the flume(s) will be incorporated into dams made of sand bags and plastic sheeting (or equivalent). The upstream dam will be constructed first and will funnel stream flow into the flume(s). The downstream dam will prevent backwash of water into the trench and construction work area. The dams will be continuously monitored for a proper seal.

Adjustments to the dams will be made where necessary to prevent large volumes of water from seeping around the dams and into the trench and construction work area.

- After the stream bed is dewatered, backhoes located on one or both stream banks will excavate a trench across the stream bed. Spoil generated during trenching will be stored in a straw bale/silt fence containment area located away from the stream banks within approved construction work areas. Existing streambed material will be segregated and placed within a spoil containment structure in approved construction work area limits.
- Trench (earth) plugs between the stream and the upland trench will be used, during excavation of the in-stream trench to prevent diversion of the stream flow into the open trench or upland sediment flowing into the stream via the trench. Trench plugs will be removed immediately before pipe placement, and then replaced when the pipe is in place.
- If trench dewatering is necessary to complete the installation of the pipe, the discharge will be pumped into a sediment filter bag or a straw bale dewatering structure in such a manner that no heavily silt-laden water flows into streams or wetlands (see Section 5.0). Non-woven fabric must be used for filter bags.
- Backfilling will begin after the pipe is positioned in the trench to the desired depth. Backfill material will consist of the spoil material excavated from the trench and parent streambed unless otherwise specified in state or federal permits. The in-stream trench will be backfilled so that the stream bottom is similar to its pre-construction condition, with no impediments to normal water flow.

### **Temporary Stabilization**

Restoration of the ROW and the installation of temporary erosion controls will be similar to that described for the wet trench method above. After the stream banks have been stabilized, the dams and flumes will be removed from the stream bed allowing water to resume its flow in the channel.

### **2.6.4 Directional Drill and/or Guided Bore Method**

#### **Installation**

Installing the pipe underneath a stream will involve placing a drill unit on one side of the stream (see Figure 15). A small-diameter pilot hole will be drilled under the stream along a prescribed profile. After the pilot hole has been completed, barrel reams will be used to enlarge the pilot hole to accommodate the desired pipeline diameter. Drilling mud will be necessary to remove cuttings and maintain the integrity of the hole. Water from an approved source (typically the river to be crossed) will be used to prepare the slurry of drilling mud, and will be appropriated according to applicable permits. The pipe section will be pulled through the hole by the drilling rig and welded to the adjoining sections of pipe on each side of the river.

## **Drilling Mud**

During drilling operations, drilling mud and slurry will be stored back from the river bank in an earthen berm sediment control structure, in tanks, or by other methods so that it does not flow into the stream, adjacent wetlands or off the workspace.

Enbridge has developed a contingency plan to address measures to be performed in the event of a release of drilling mud onto the ground surface or waterbody. See the Enbridge *Drilling Mud Containment, Response, and Notification Plan* for additional details.

After the pipe is in place, excess drilling mud and slurry will be spread over an upland area approved by Enbridge and the landowner, or hauled off site to an Enbridge approved disposal location.

## **Temporary Stabilization**

The directional drilling/guided bore method normally does not result in the disturbance of the stream banks or riparian vegetation, which reduces the potential for erosion and sedimentation at the stream crossing. Consequently, temporary erosion control measures that are installed at open-cut crossings typically are not necessary for drilled/bored crossings.

## **2.7 PERMANENT RESTORATION**

### **Stream Banks**

Stream banks disturbed during installation of the pipelines will be stabilized with erosion control materials such as jute or equivalent and seeded in accordance with Enbridge's Revegetation and Restoration Monitoring Plan. Permanent stabilization will be initiated within 24 hours after installation of the crossing, unless site and permit conditions delay permanent installation. Where the banks have been disturbed, Enbridge will restore the slopes as near as practicable to pre-construction conditions unless that slope is determined to be unstable. Where the slope of the banks is determined to be unstable or has the potential to erode or fail, the banks will be reshaped to transition the disturbed areas into the natural stream bank with the intent to stabilize the bank and create a blended, natural appearance.

Berms or other sediment filter devices will be installed at the base of sloped approaches to streams greater than five percent and the outlet of the berm will be directed away from the stream into a well vegetated area (see Figure 4). Temporary sediment control devices will remain in place until the area has stabilized and adequate revegetation has established.

#### **2.7.1.1 Vegetative Bank Restoration**

Typically, waterbody banks will be restored as near as practicable to preconstruction conditions after backfilling is complete and will be seeded with an appropriate seed mix as specified in the Revegetation and Restoration Monitoring Plan. Erosion controls, (e.g. erosion control blankets, silt fences, etc.) will be installed as necessary based on site-specific conditions.

#### **2.7.1.2 Rock Riprap Restoration**

Unstable soils and/or site-specific factors such as stream velocity and flow direction may require additional restoration efforts, such as installation of rock rip-rap, to stabilize disturbed

stream banks. Rock rip-rap will be used only where site-specific conditions require and where applicable state permits or approvals have been acquired. Geotextile fabric and rock riprap will be placed according to site and permit conditions (see Figure 19). Disturbed soils upslope and on either side of the riprap will be prepared for seeding according to the *Revegetation and Restoration Monitoring Plan* and other stream bank protection requirements.

### **2.7.1.3 Bridge Removal**

Equipment bridges will be removed during final cleanup or, if access is needed, after final cleanup and permanent seeding. Restoration of the bridge area will be completed upon bridge removal. Bridges installed for winter construction (if applicable) will be removed before spring break up.

### **2.7.1.4 Swales**

Swales will be restored as near as practicable to original conditions. Swales will be seeded and either mulched with straw or erosion control blankets will be installed to the perceivable top of bank for the width of the ROW.



### **3.0 WETLAND CROSSING GENERAL REQUIREMENTS**

Typical pipeline construction in wetlands will consist of clearing, stringing, trenching, dewatering, installation, backfilling, final grading, cleanup, and revegetation. However, due to the unstable nature of some wetland soils, construction activities may differ somewhat from those described for upland areas. Construction activities will be minimized in wetlands to the extent practicable. Enbridge will also use special construction techniques to minimize the disturbance to plants and soils and to protect wetland hydrology.

Pre-construction planning is an essential part of wetland crossings. Wetland crossing requirements, including construction methods, timing, erosion control, and restoration, are described in this section and in the wetland crossing permits issued by state and federal agencies. If the Contractor considers certain parts of these procedures to be technically impractical due to site-specific engineering constraints, the Contractor may seek modifications via the Variance Request Process. The Variance Request Process will be developed in conjunction with state and federal regulatory agencies and may differ between states. Prior to construction, the Contractor must identify alternative provisions that would provide an equal or greater level of protection to wetland ecosystems. Enbridge will review the Contractor's alternatives and consult with appropriate regulatory agencies. The Contractor must receive approval from Enbridge prior to implementing the alternatives.

The procedures in this section apply to all wetlands that will be affected by the project. These procedures require that judgment be applied in the field and will be implemented under the supervision of the Enbridge and the EI. The intent of these procedures is to minimize construction-related disturbance and sedimentation of wetlands and to restore wetlands as nearly as possible to pre-existing conditions.

#### **3.1 WETLAND ACCESS**

The Contractor must use the construction ROW and only approved roads to access wetland areas.

#### **3.2 SPILL PREVENTION**

##### **3.2.1 Storage of Fuels and Other Materials**

No storage of hazardous materials, chemicals, fuels, and lubricating oils, and no concrete coating activities will be permitted in, or within 100 feet of, any wetland unless special provisions have been implemented in accordance with Enbridge's Spill Plan. Vehicles and equipment left on the ROW overnight must be parked at least 100 feet from a delineated wetland unless special provisions have been implemented in accordance with Enbridge's Spill Plan.

##### **3.2.2 Refueling, Fuel Handling, and Equipment Maintenance**

Construction equipment will be refueled in upland areas at least 100 feet from a wetland. Where the Contractor and EI determines that conditions require construction equipment (e.g., swamp hoe, trench dewatering pumps, or portable generators) to be refueled within 100 feet of a wetland, the Contractor must follow the procedures described in Enbridge's Spill Plan and

implement additional provisions based on site-specific conditions. No equipment will be washed within 100 feet of streams or waterbodies. Overnight parking of equipment is not allowed within 100 feet of a wetland unless special provisions have been implemented in accordance with Enbridge's Spill Plan. Maintenance (e.g., lubricating) of construction equipment will not be allowed within the 100 foot buffer zone without approval from the EI with additional special provisions for containment.

### **3.3 CLEARING**

Clearing the construction ROW in wetlands will be similar to clearing in uplands. For construction to proceed, obstructions (e.g., trees, brush, and logs) need to be removed. Typically, low ground pressure equipment will be used, limiting disturbance to the wetland. When clearing in wetlands, the following restrictions apply:

- The construction ROW width will typically be limited to 125 feet.
- Vegetation and trees within wetlands will be cut off at ground level, leaving existing root systems intact; clearing debris will generally be removed from the wetland for disposal. Hydro-axe debris, or similar, can be left in the wetland if spread evenly in the ROW to a depth not to exceed 1 inch in thickness and in a manner, as determined by the EI, which will allow for normal revegetation.

#### **Extra Workspace in Wetlands**

Enbridge attempted to locate EWS outside of wetlands wherever practicable; however, EWS have been sited in select wetlands where the wetland is adjacent to a waterbody, road, railroads, foreign utility crossings, and/or pipeline cross-over. Clearing of forested wetlands for EWS will be avoided as much as possible. Woody vegetation in wetlands will not be cleared for the purpose of EWS unless approved by appropriate regulatory agency.

- Staging areas, additional spoil storage areas, and other additional work areas (EWS) will be located in upland areas at least 50 feet away from wetland boundaries (see Figure 20), where safe work practices or site conditions permit. If site conditions do not permit a 50-foot setback, then these areas will be located as far away from the wetland as is practicable. Vegetation will not be cleared between these areas and the wetland in any event. No construction activities including vegetation clearing or earthwork will occur between the EWS and sensitive resource areas (wetlands or waterways).
- The size of the additional workspace areas will be limited to the minimum needed to construct the wetland crossing.

### **3.4 GRADING IN A WETLAND**

Grading in a wetland, if required, will be conducted in a manner consistent with applicable federal, state, and local permits. Grading activities will be confined to the area of the trench. Grading outside the trench is only permitted where required to ensure safety and restore the ROW after backfilling the trench.

ECDs (e.g., silt fence) will be installed across the entire construction ROW upslope of the wetland boundary, where necessary, to prevent sediment flow into the wetland. Where wetlands are adjacent to the construction ROW and the ROW slopes toward the wetlands,

ECDs will be installed along the edge of the construction ROW as necessary to prevent sediment flow into the wetlands. ECDs will be installed along the edge of the construction ROW, as necessary, to contain spoil and sediment within the construction ROW through wetlands.

ECDs will be maintained in proper working order to prevent the flow of sediment into wetlands from spoil piles or sloped approaches that are adjacent to the wetlands. When the depth of sediment reaches one-third of the height of a sediment barrier, the barrier will be replaced and/or the sediment removed. Non-functional erosion and sediment control features must be repaired, replaced, or supplemented with functional materials within 24 hours after discovery, or as soon as field conditions allow the features to be repaired.

### **3.5 CONSTRUCTION MATTING**

Supplemental equipment supports, such as timber mats (see Figure 20), will be used in wetlands where necessary to provide temporary portable support for construction equipment and minimize soil compaction and/or soil mixing. No more than two layers of equipment mats will be used to support equipment on the construction ROW unless prior approval is obtained from Enbridge. The Contractor is responsible for having a sufficient number of construction mats to perform the work. Tree stumps, brush riprap, imported soil, and rock fill shall not be brought in to stabilize the ROW in wetlands. Timber riprap (also known as corduroy road) cannot be used without prior written approval from the company and the appropriate regulatory agencies. Pre-existing corduroy roads in wetlands may be used but may not be improved, maintained, restored, or replaced without site-specific authorization from applicable agencies. Subsoil excavated from the pipeline trench in the wetland may be placed on top of equipment mats for additional stabilization.

All timber mats, construction debris, and larger woody vegetative debris (greater than 1.5 inch diameter) will be removed during cleanup of wetlands.

### **3.6 TRENCHING**

Excavation of the pipeline trench in wetlands typically will be accomplished using backhoe excavators. The duration of open trench will be minimized to the extent possible.

#### **3.6.1 Topsoil Segregation**

Typically, when constructing in wetland areas without standing water, up to one foot of topsoil (organic layer) will be stripped from the trench line and stockpiled separate from trench spoil (see Figure 3) as described in section 1.7.8: Trench-Line Only Topsoil Segregation Method. In standing water wetlands, organic soil segregation is not typically practical; however, Enbridge will attempt to segregate as much of the organic layer as possible based on site/saturation conditions. If normally unsaturated wetlands are saturated at the time of construction, topsoil segregation will be attempted according to Figure 20 and based on recommendations from the EI and appropriate regulatory agencies.

#### **3.6.2 Trench Breakers**

Where the EI determines that the pipeline trench has the potential to drain or partially drain a wetland, trench breakers will be installed as necessary to maintain the original wetland hydrology.

### **3.7 PIPELINE INSTALLATION**

The following procedures are intended to minimize siltation and disturbance to wetlands during installation.

#### **3.7.1 Push/Pull Method**

Large wetlands with standing water can generally not be crossed with typical crossing methods. In these areas, the pipeline will be assembled in an upland area and positioned in the trench using the "push-pull" and/or "float" techniques.

Usually this fabrication requires use of extra temporary workspace adjacent to the ROW. The trench will be dug by a backhoe (or equivalent) supported on timber mats. The prefabricated section of pipeline will then be pushed-pulled into position or floated across the wetland. When the pipeline is in position, floats, if used, will be removed and the pipeline will sink into position. The trench will then be backfilled and the wetland will be restored by a backhoe or similar equipment working from construction mats or by low ground pressure equipment.

#### **3.7.2 Temporary Erosion and Sediment Controls**

ECDs at approaches to wetlands will be installed as described in section 1.7.9 and 3.4, according to the specifications presented on Figures 6 and 7.

#### **3.7.3 Concrete Coating**

Concrete will generally be mixed off-site, and concrete coated pipe will be transported to the ROW on trucks. If required, pre-fabricated concrete weights and/or saddlebag weights will also be used to provide negative buoyancy. Concrete weights will be manufactured off-site and transported to the ROW. Weights will be strung along the construction ROW, where necessary, until they are placed over the pipe within the excavated ditch. Limited mixing and coating activities may occur on the construction ROW for coating pipe joints and concrete weight repairs according to the concrete usage specifications in Enbridge's Spill Plan. Washing equipment used for mixing, pouring, casting, or coating will not be conducted within 100 feet of any wetland and will be conducted and contained in a leak-proof containment facility or impermeable liner. Erosion and sediment controls will be installed downslope of equipment wash areas where needed to capture sediments and minimize erosion from runoff. Concrete coating on the pipe must be cured for a minimum of 3 days prior to installation in a wetland due to potential toxic effects on wetland and aquatic biota.

### **3.8 BACKFILLING**

The Contractor shall restore wetlands as near as practicable to pre-construction conditions and must make a reasonable attempt to return the subsoil its pre-construction density. During backfilling of wetland areas, subsoil material removed from the trench during construction will be replaced so that the material is not mounded above the adjacent ground surface (undisturbed trench wall). Subsoil that exceeds the elevation of the ground adjacent to the trench will be removed from the wetland and disposed of in an upland area or approved disposal site. After the trench has been backfilled with subsoil, previously segregated topsoil will be spread over the trench area and mounded no more than 12 inches above the adjacent, undisturbed soil.

### **3.9 ROUGH GRADING, CLEANUP, AND TEMPORARY RESTORATION**

Cleanup and rough grading activities may take place simultaneously. Cleanup typically will involve removing construction debris and replacing fences removed during construction. Rough grading will include restoring original conditions within the disturbed areas (i.e., ditch line, spoil storage areas, and equipment travel lane) and installing or repairing temporary erosion control measures. Temporary slope breakers will be installed near the boundary between the wetland and adjacent sloped approaches, to prevent sediment flow into the wetland.

#### **3.9.1 Timing**

Cleanup and rough grading (including installation of temporary erosion control measures) will begin as soon as practical after the trench is backfilled, weather permitting.

#### **3.9.2 Temporary Stabilization**

Where necessary to prevent erosion, disturbed wetland areas will be stabilized by seeding with a temporary cover in accordance with Enbridge's *Revegetation and Restoration Monitoring Plan*.

No fertilizer, lime, or mulch will be applied in wetlands. Enbridge does not propose permanent planting or seeding in wetlands, except in accordance with restoration and compensatory mitigation plans and procedures that are being developed cooperation with the U.S. Army Corps of Engineers.

## **4.0 HIGHWAY, ROAD AND RAIL CROSSINGS**

### **4.1 ADDITIONAL WORKSPACE**

Additional workspaces for bored road and railroad crossings and open-cut road crossings will be determined on a site-specific basis. These workspaces will be adjacent to the road or railroad and limited to the size needed to contain spoil from the crossing.

### **4.2 MAINTENANCE**

Roadway crossings will be maintained in a condition that will prevent tracking of mud onto the roadway. If mud is tracked onto a roadway, the Contractor shall remove accumulated material from the road and place within a sediment barrier as soon as possible, but in no circumstances more than 24 hours after discovery.

Rock tracking pads, constructed of stone no smaller than 4-inch or as required by the applicable permits, will be installed adjacent to paved public roads to prevent or minimize the tracking of soil onto the roadway. If the roadside ditch is part of a jurisdictional waterway, a permit must be obtained prior to installing the tracking pad or culvert. If permitted in wetlands, tracking pads will be limited in size to reduce impacts. Tracking pads installed in wetlands must be constructed with clean rock placed on geotextile fabric. All rock and fabric must be removed from the wetland during cleanup.

### **4.3 TEMPORARY EROSION AND SEDIMENT CONTROLS**

Temporary ECDs (e.g., silt fence and/or double-staked straw bales) will be installed on sloped approaches to road crossings where vegetation has been disturbed (see Figures 21) and as discussed in section 1.7.9.

## 5.0 CONSTRUCTION DEWATERING

### 5.1 TRENCH DEWATERING

The following additional guidance is being provided regarding dewatering activities to employ the maximum amount of reasonable protective measures to wetland and waterbody locations.

At each location where dewatering is to be conducted, the contractor must consider the following conditions in planning the dewatering event. Prior to initiating dewatering activities, the environmental inspector shall check the water discharge situation to ensure that the best management practices are applied in such a way as to minimize the potential for water containing sediment from reaching a waterbody.

1. **Water Discharge Setting** – The contractor shall assess each water discharge situation to include:
  - a. Soil Type - The soil type the discharged water would flow over. The management of discharged water traveling over sandy soil is more likely to soak into the ground as compared to clay soils.
  - b. Ground Surface - The topography in the area that would influence the surface flow of the discharged water.
  - c. Adjustable Discharge rate - The flow rate of the discharged water (which may need to vary) can be managed based on the site conditions to minimize instances of water from reaching a waterbody. (Example - Water discharged at 500 gallons per minute may soak into the ground while if discharged at a higher flow rate would cause water to flow via overland runoff into a waterbody)
  - d. Discharge Outfall - The amount of hose (utilizing up to 300 feet) needed to attempt to discharge water at a location which drains away from waterbodies or wetlands.
2. **Pump Intake** - Use floating suction hose or other similar measure to prevent sediment from being sucked from bottom of trench.
3. **Overwhelming Existing Drainage** - If the discharge (assumed to be clean) does enter a stream, the flow added to the stream cannot exceed 50 percent of the peak storm event flow (to prevent adding high water volumes to a small stream channel that causes erosion due to imposing high flow conditions on the stream).
4. **Filtering Mechanism** – All dewatering discharges will be directed through a filtering device as indicated below.
  - a. Well Vegetated Upland Area – Water can be directed to a well-vegetated upland area through a geotextile filter bag. The ground at the discharge location shall be protected with a sheet of plywood or similar means to prevent scouring/erosion of the ground surface at the end of the discharge hose. Geotextile bags need to be sized appropriately for the discharge flow and suspended sediment particle size according to WDNR Dewatering Standard 1061V. C. Also, as stated in Standard 1061 VI.B, the use of geotextile bags are generally not appropriate when discharging water would

reach Outstanding Resource Waters (ORWs), Exceptional Resource Waters (ERWs), or trout streams.

- b. Straw Bale Dewatering Structure – Where the dewatering discharge point cannot be located in an upland area due to site conditions and/or distance, the discharge should be directed into a straw bale dewatering structure. The size of the straw bale dewatering structure is dependant on the maximum water discharge rate. The size of the structure is dictated on the Typical Straw Bale Dewatering Figure in the Enbridge Environmental Mitigation Plan (see Figure 18). A straw bale dewatering structure should be used in conjunction with a geotextile filter bag to provide additional filtration near sensitive resource areas.
- c. Alternative dewatering methods (e.g. use of water canons) may be approved by Enbridge on a site-specific basis.

### **5.1.1 Regulatory Notification and Reporting**

Enbridge will notify appropriate state agencies as required by all permits/authorizations.

Reports regarding the volume and quality of the water withdrawn and discharged will be submitted by Enbridge, as required by the applicable state permit. The Contractor will assist Enbridge in collecting appropriate data and any water samples required or in determining volumes of water appropriated.

### **5.1.2 Flow Measurement**

The volume of water discharged from the trench must be recorded as required by the applicable permits. The volume may be determined using a flow meter, or equivalent method as dictated by permit stipulations.

### **5.1.3 Water Sampling**

Water discharged from trench dewatering locations may need to be sampled as required by state-issued WPDES discharge permits. If required, the Contractor will assist Enbridge in obtaining these samples and will be responsible for complying with the permit limitations.

## **5.2 HYDROSTATIC TEST DISCHARGES**

Hydrostatic testing involves filling the new pipeline segments with water acquired in accordance with applicable permits (See section 6.0), raising the internal pressure level, and holding that pressure for a specific period of time per federal Department of Transportation specifications. Hydrostatic testing will be done to verify that there are no flaws in the pipe or welds. Pre-built sections may be hydrostatically tested prior to installation at significant streams and wetland crossings. Water used for hydrostatic testing will be discharged back to the waterbody it was appropriated from. After the hydrostatic test is completed, the line will be depressurized and the water expelled. During withdrawal and discharge, the water will be sampled as required by permits. Water volumes must be measured and recorded.

If site conditions or engineering constraints make adhering to these hydrostatic testing procedures and documentation impractical, Enbridge will propose alternative provisions to the regulatory agency issuing the WPDES permit. Any such alternative will provide an equal or



greater level of protection to the environment than the condition from which Enbridge or its Contractor seeks relief.

### **5.2.1 Refueling**

The operation and refueling of hydrostatic test equipment will be in accordance with the conditions outlined in Enbridge's Spill Plan.

### **5.2.2 Permit Requirements**

Hydrostatic testing will be conducted in accordance with applicable appropriation and discharge permits obtained by Enbridge. Hydrostatic test waters will not be transferred from one waterbody to another, across watershed, or major drainage divides. Chlorinated source water will be sampled at appropriation. If chlorine levels are at or above aquatic toxicity standards, the water will not be discharged to a surface water.

### **5.2.3 Siting of Test Manifolds**

Hydrostatic test manifolds will be installed where necessary to ensure proper test pressures. However, the selected location of test manifolds is based on engineering requirements to meet proper test pressures and incorporates changes due to topography. Where feasible, Enbridge will incorporate minor adjustments to the test manifold locations to avoid placement in wetlands and riparian areas. However, completely avoiding the placement of a test manifold in a wetland may not always be possible. The Contractor shall install appropriate erosion control measures where the EI determines that topographic conditions, primarily elevation changes, require test sections to be located in a wetland or riparian area.

### **5.2.4 Water Sampling**

Water discharged from hydrostatic tests will be sampled as required by state-issued appropriation or discharge permits. Hydrostatic water discharges will comply with permit limitations as required by the applicable WPDES permit conditions. If required, the Contractor will assist Enbridge in obtaining these samples and will be responsible for complying with the permit limitations.

### **5.2.5 Best Management Practices**

Prior to hydrostatic testing the pipeline, Enbridge will prepare the pipe by removing accumulated construction debris, mill scale, dirt and dust using a cleaning pig. The debris will be collected in a temporary receiver and shall be properly disposed of by the Contractor. Upon completion of the cleaning operation, the pipeline will be sealed with the test headers.

Test headers and pigs will be arranged to allow for rinse water to be installed ahead of the fill pigs. Rinse water must be treated and disposed of in accordance with applicable permit conditions.

Following testing, the test section will be depressurized and the water will be discharged to a well-vegetated, upland area or an appropriate dewatering structure. Dewatering structure include geotextile filter bags and/or a hay bale structure that may or may not be lined with geotextile fabric. Direct discharges to surface waters will be directed with an energy dissipation device such as a splash pup.

At no time will the discharge rate exceed the applicable discharge rates specified in state-issued or other discharge permits. In the event no maximum discharge rate is identified, discharges shall be monitored and adjusted as necessary to avoid scouring or sediment transport from the discharge location.

To minimize the potential for introduction and/or spread of invasive species due to hydrostatic testing activities, Enbridge proposes to discharge water to the same source location from which it was appropriated. If water is used to test multiple test sections, it will be relayed back to the source water through the pipeline for final discharge. Test water will not be discharged to a waterbody other than the appropriation source, unless coordinated and permitted through the applicable agencies.

In Wisconsin, Enbridge will clean hydrostatic test equipment (e.g., pumps, hoses, piping, splash pups, etc.) by inspecting equipment for mud and vegetation debris and draining any lake or river water from the equipment. In addition, Enbridge will implement one of the following additional provisions for cleaning hydrostatic testing equipment when the air temperature is above 19 degrees Fahrenheit at the time the decontamination procedures take place:

- Allow equipment to dry thoroughly for not less than five days between usage at other hydrotesting sites prior to transport between test sites;
- Wash equipment with hot water (temperature not less than 212 degrees Fahrenheit);
- Wash equipment with soap and water or high pressure water of not less than 2,000 pounds per square inch pressure;
- Disinfect equipment with 200 parts per million (0.5 ounces per gallon) chlorine for not less than 10 minutes contact time; or,
- Disinfect with another approved disinfectant.

### **5.2.6 Flow Measurement**

The total volume of water discharged will be determined with a flow meter (or equivalent), or as required by the applicable state permit. The total volume of water discharged will not exceed the volume specified in the applicable permit.

## **6.0 WATER APPROPRIATION**

### **6.1 GENERAL**

Water may be drawn from local sources, such as lakes, streams, and private or municipal wells for construction activities such as dust control, horizontal directional drilling/guided boring, trench dewatering, and hydrostatic testing. The project will follow applicable permit conditions for the appropriation of water.

Where water is appropriated from lakes or streams, the intake hose will be suspended off of the stream or lake bottom and will be screened to prevent entrainment of fish. During withdrawal, adequate waterbody flow rates and volumes will be maintained to protect aquatic life and allow for downstream uses. The volume and rate of withdrawal will be monitoring to comply with applicable permit conditions.

### **6.2 WATER SOURCES**

Water will only be withdrawn from sources approved by Enbridge and in accordance with applicable permits. No additives to the water are permitted unless written approval is received from Enbridge and applicable permits authorize such additives.

If appropriation is scheduled to occur during possible periods of low flow, including frozen conditions, a backup source will be identified.

### **6.3 FLOW MEASUREMENT**

At no time will the withdrawal rate for the water source exceed the rate specified in the applicable permits.

The withdrawal rate and total volume of water appropriated must be measured with a flow meter (or equivalent) and recorded as required by the state-issued permit.

### **6.4 WATER SAMPLING**

Where required by permit conditions, Enbridge will sample the water during appropriation. The Contractor will assist Enbridge in obtaining these samples.

### **6.5 REGULATORY NOTIFICATION AND REPORTING**

Enbridge will notify appropriate state agencies of the time of appropriations if required by the state appropriations permits. Reports regarding the volume and quality of the water withdrawn will be submitted by Enbridge if required by the state permit.

## 7.0 REVEGETATION

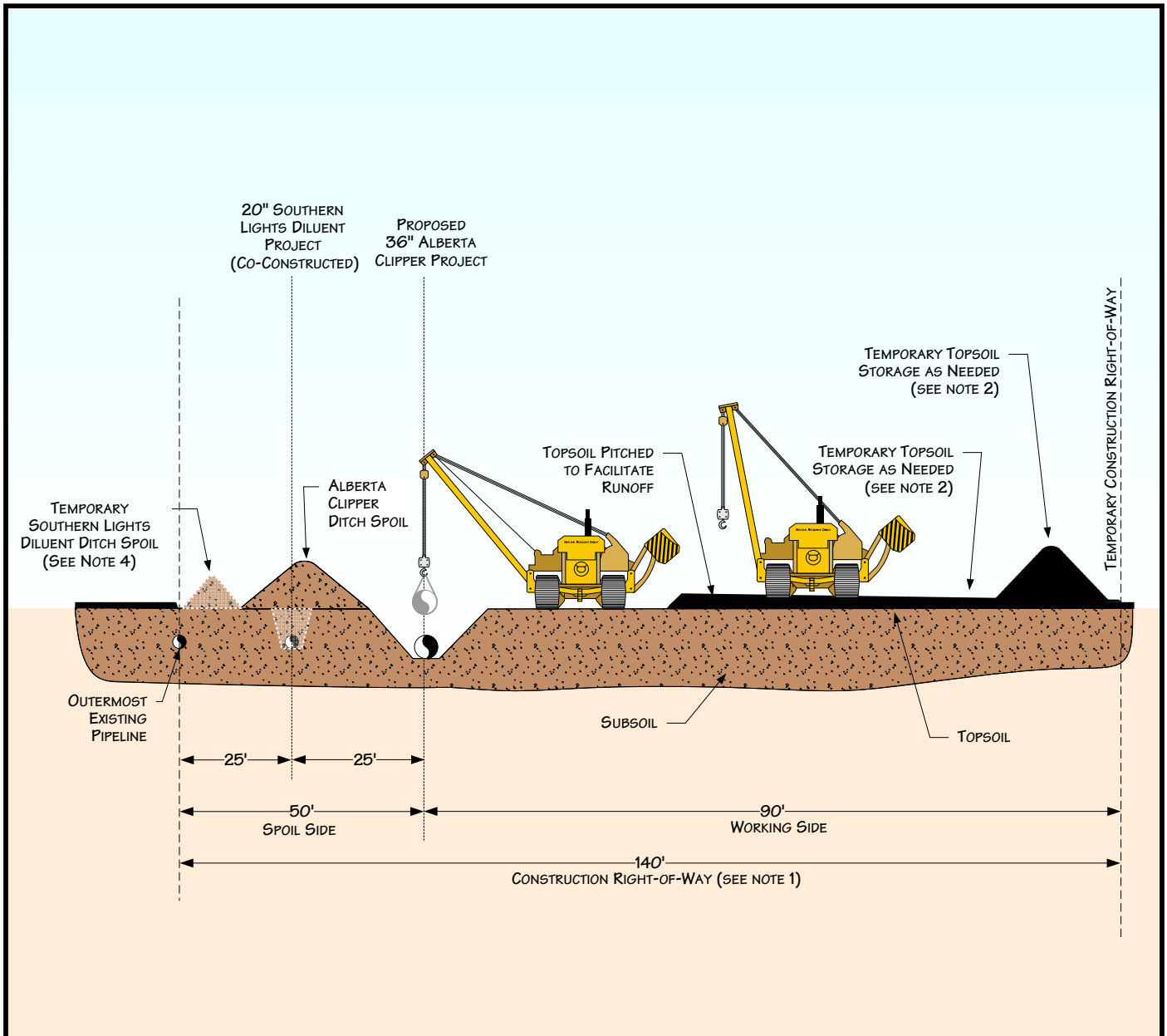
Permanent revegetation will involve preparing the seedbed and seeding disturbed, non-agricultural areas. The ROW will be seeded as soon as possible after backfilling, weather and soil conditions permitting. With the exception of wetland areas, fertilizer and pH modifying agents (e.g., lime) will be applied as specified by Enbridge, in consultation with appropriate state and federal agencies and Landowners. Refer to Enbridge's Revegetation and Restoration Monitoring Plan for specific information.

ISSUED FOR PERMITTING

# Environmental Mitigation Plan

## Figures

ISSUED FOR PERMITTING



**PROFILE**

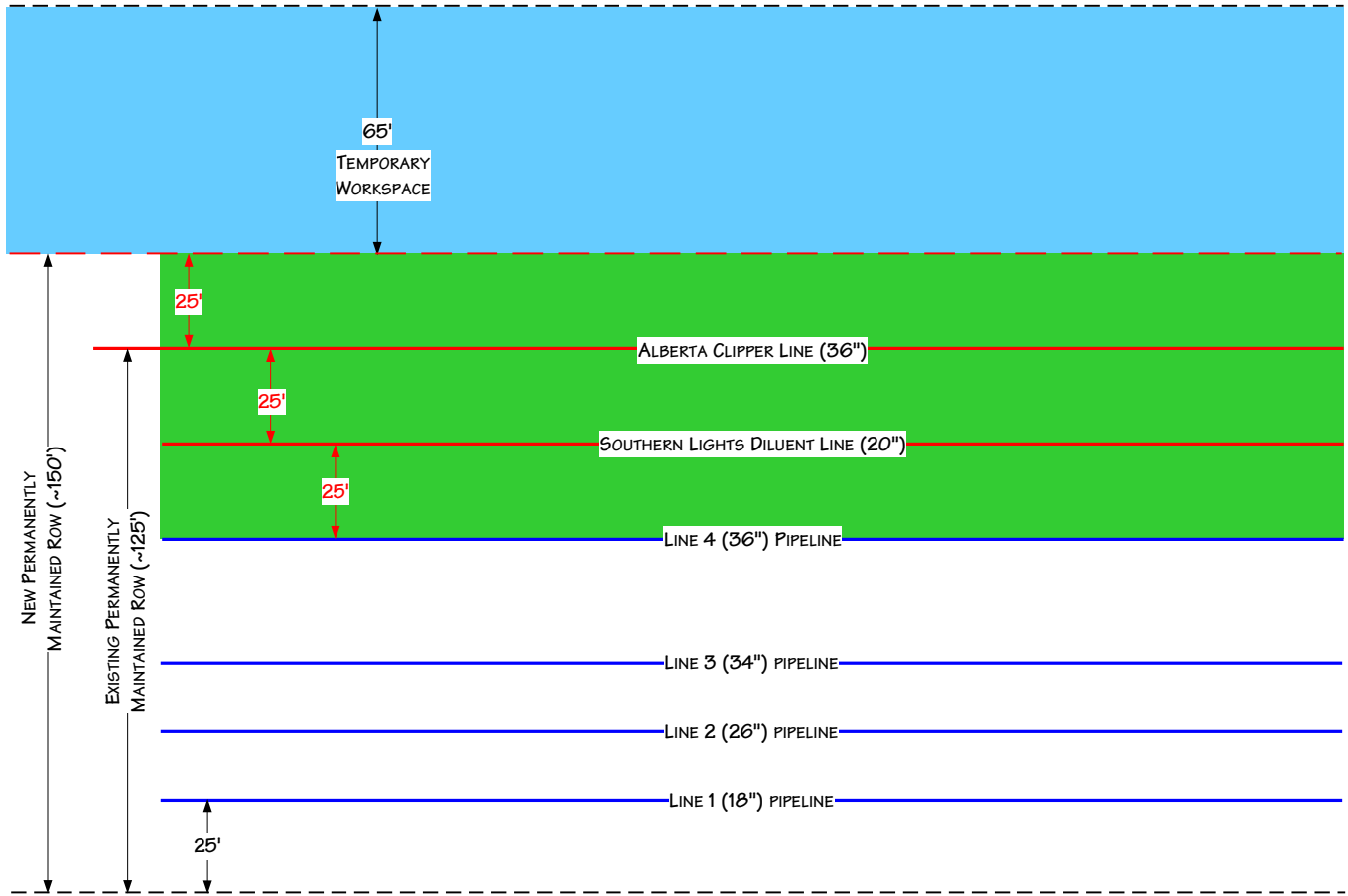
**NOTES:**

1. CONSTRUCTION RIGHT-OF-WAY WILL TYPICALLY BE 140' WIDE. THE SPOIL SIDE WILL BE APPROXIMATELY 50' WIDE AND GENERALLY WITHIN THE EXISTING MAINTAINED RIGHT-OF-WAY. THE WORKING SIDE WILL BE 90' WIDE.
2. STOCKPILE TOPSOIL SEPARATELY FROM DITCH SPOIL AS SHOWN OR IN OTHER CONFIGURATIONS APPROVED BY THE COMPANY.
3. THE OFFSET FROM NORTHERNMOST OR SOUTHERNMOST EXISTING PIPELINE, WHERE APPLICABLE, WILL BE 25' FOR MOST LOCATIONS BUT MAY BE INCREASED OR DECREASED DEPENDING ON THE SITE SPECIFIC CONSTRUCTION REQUIREMENTS.
4. SOUTHERN LIGHTS PIPELINE TRENCH SPOIL TO BE BACKFILLED PRIOR TO EXCAVATION OF THE ALBERTA CLIPPER PIPELINE TRENCH.



**Figure 1**  
**Environmental Mitigation Plan**  
 Typical Construction Layout  
 Topsoil Segregation  
 Modified Ditch Plus Spoil Side  
 (Wisconsin Only)

DATE: 7/9/2001	
REVISED: 1/16/08	
SCALE: NTS	
DRAWN BY: KMKENDALL	
K:\335\WL_EMP\FIGURE01.VSD	



- TYPICAL EXISTING ROW BOUNDARY DEFINED BY LOCATION OF SOUTHERN MOST PIPELINE: UP TO 25 FEET TO THE SOUTH AND 100 FEET TO THE NORTH.
- TEMPORARY WORKSPACE ADJACENT TO NEW ADDITIONAL PERMANENT ROW WILL BE REQUIRED TO INSTALL THE PIPELINE(S). TYPICALLY 65' IN WIDTH AND THE LENGTH OF THE ROW WILL BE RENTED FROM LANDOWNERS. ADDITIONAL TEMPORARY WORKSPACE AT CIVIL AND ENVIRONMENTAL CROSSINGS OF UP TO 75' IN WIDTH AND UP TO 300' IN LENGTH ON EACH SIDE OF THE CROSSING WILL BE RENTED.

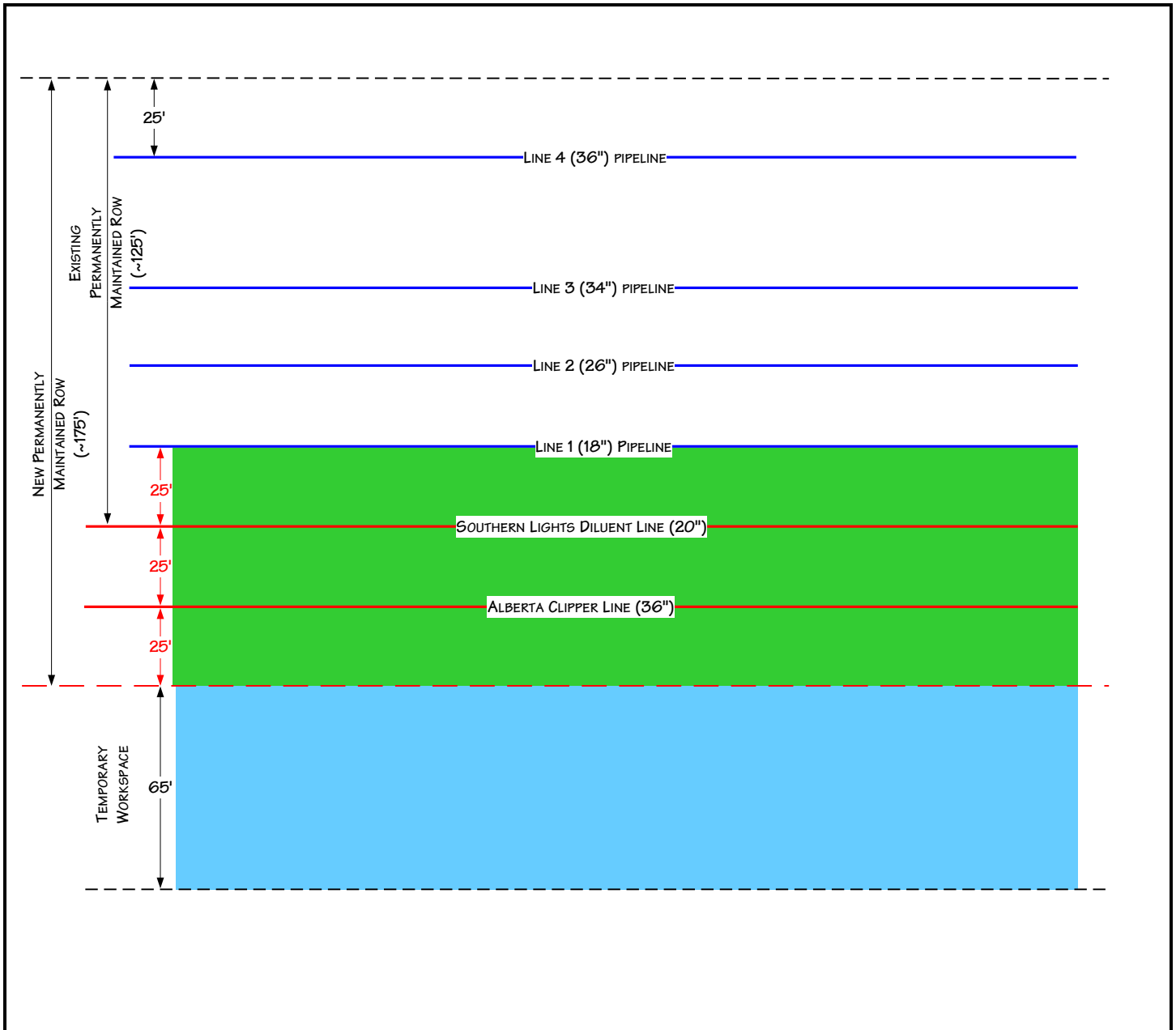


For environmental review purposes only.



**Figure 2A**  
**Alberta Clipper and Southern Lights Diluent Projects**  
 Typical Right-of-Way Configuration North of Existing Lines  
 (Wisconsin Only)

DATE: 5/23/2007	
REVISED: 12/11/08	
SCALE: NTS	
DRAWN BY: RSMcGregor	
K:\335\WI_EMP\FIGURE02A.VSD	



- TYPICAL EXISTING ROW BOUNDARY DEFINED BY LOCATION OF NORTHERN MOST PIPELINE: 25 FEET TO THE NORTH AND 100 FEET TO THE SOUTH.
- TEMPORARY WORKSPACE ADJACENT TO NEW ADDITIONAL ROW WILL BE REQUIRED TO INSTALL THE PIPELINE(S). TYPICALLY 65' IN WIDTH AND THE LENGTH OF THE ROW WILL BE RENTED FROM LANDOWNERS. ADDITIONAL TEMPORARY WORKSPACE AT CIVIL AND ENVIRONMENTAL CROSSINGS OF UP TO 75' IN WIDTH AND UP TO 300' IN LENGTH ON EACH SIDE OF THE CROSSING WILL BE RENTED.



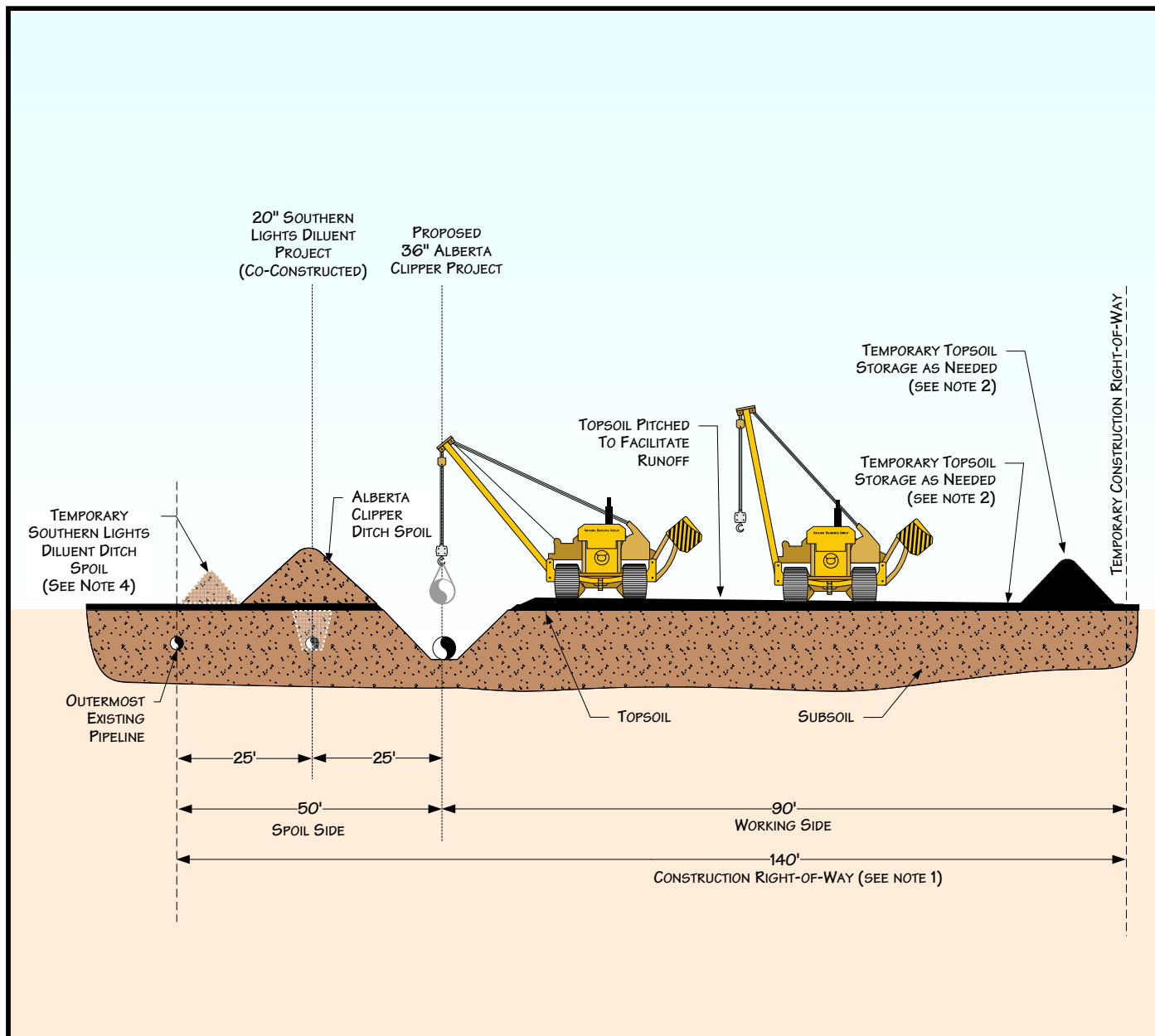
For environmental review purposes only.



**Figure 2B**  
**Alberta Clipper and Southern Lights Diluent Projects**  
 Typical Right-of-Way Configuration South of Existing Lines  
 (Wisconsin Only)

DATE: 5/23/2007	
REVISED: 12/11/08	
SCALE: NTS	
DRAWN BY: RSMcGregor	
K:\335\WI_EMP\FIGURE02B.VSD	





**PROFILE**

**NOTES:**

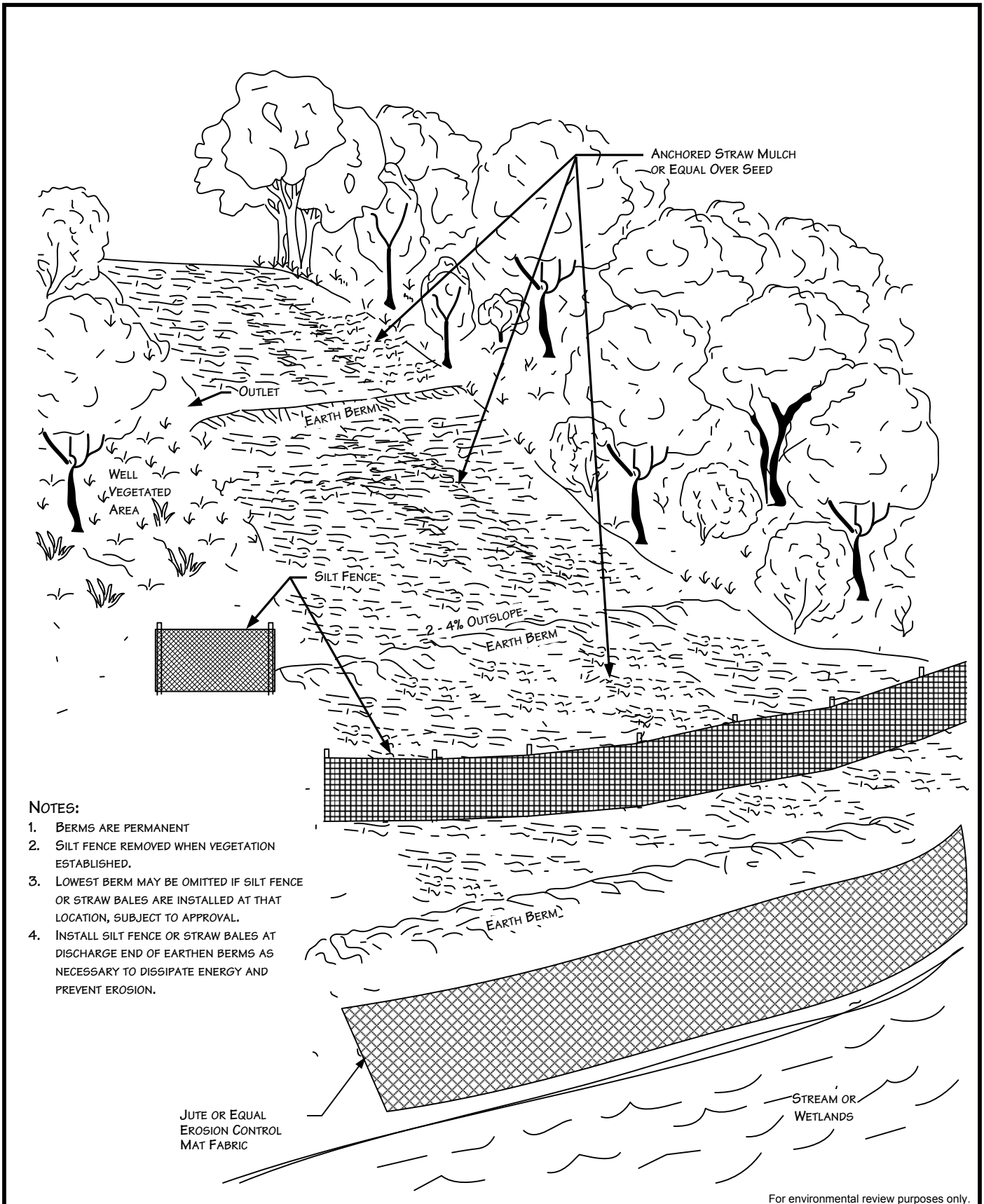
1. CONSTRUCTION RIGHT-OF-WAY WILL TYPICALLY BE 140' WIDE. THE SPOIL SIDE WILL BE APPROXIMATELY 50' WIDE AND GENERALLY WITHIN THE EXISTING MAINTAINED RIGHT-OF-WAY. THE WORKING SIDE WILL BE 90' WIDE.
2. THIS DRAWING REFLECTS "TRENCH LINE ONLY" TOPSOIL STRIPPING PROCEDURE. STOCKPILE TOPSOIL SEPARATELY FROM DITCH SPOIL AS SHOWN OR IN OTHER CONFIGURATIONS APPROVED BY THE COMPANY.
3. THE OFFSET FROM NORTHERNMOST OR SOUTHERNMOST EXISTING PIPELINE, WHERE APPLICABLE, WILL BE 25' FOR MOST LOCATIONS BUT MAY BE INCREASED OR DECREASED DEPENDING ON THE SITE SPECIFIC CONSTRUCTION REQUIREMENTS.
4. SOUTHERN LIGHTS PIPELINE TRENCH SPOIL TO BE BACKFILLED PRIOR TO EXCAVATION OF THE ALBERTA CLIPPER PIPELINE TRENCH.



**Figure 3**  
**Environmental Mitigation Plan**  
 Typical Topsoil Segregation  
 Trench Line Only  
 (Wisconsin Only)

DATE: 7/9/2001  
 REVISED: 1/16/09  
 SCALE: NTS  
 DRAWN BY: KMKENDALL





**NOTES:**

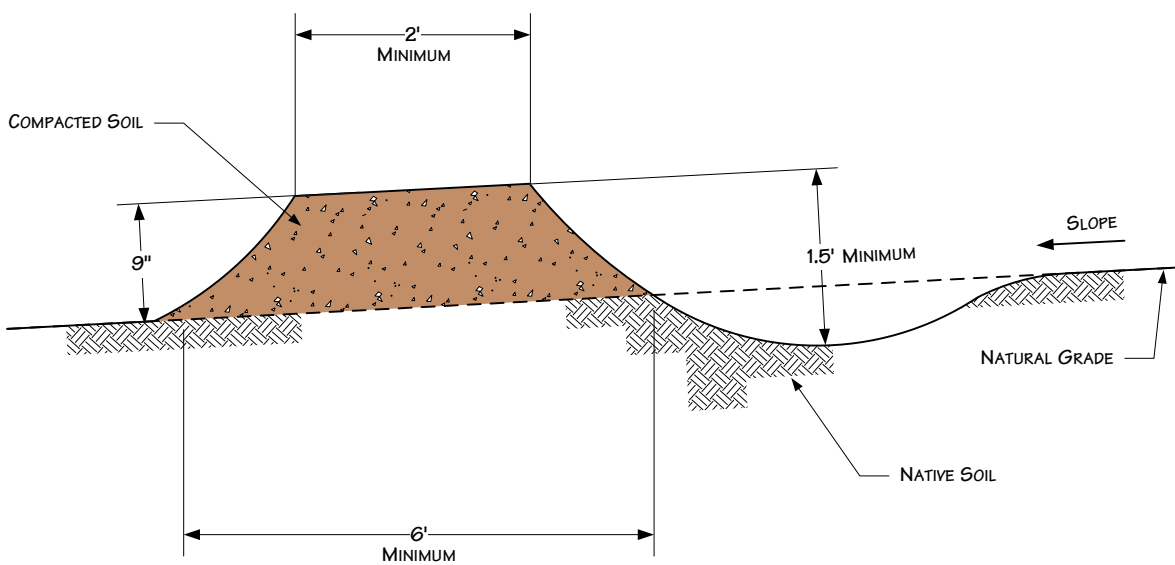
1. BERMS ARE PERMANENT
2. SILT FENCE REMOVED WHEN VEGETATION ESTABLISHED.
3. LOWEST BERM MAY BE OMITTED IF SILT FENCE OR STRAW BALES ARE INSTALLED AT THAT LOCATION, SUBJECT TO APPROVAL.
4. INSTALL SILT FENCE OR STRAW BALES AT DISCHARGE END OF EARTHEN BERMS AS NECESSARY TO DISSIPATE ENERGY AND PREVENT EROSION.

For environmental review purposes only.



**Figure 4**  
**Environmental Mitigation Plan**  
 Typical Temporary or Permanent Berms  
 Perspective View

DATE: 11/14/2000	
REVISED: 1/16/2009	
SCALE: NTS	
DRAWN BY: KMKENDALL	
K:\335\WI_EMP\FIGURE04.VSD	



**NOTES**

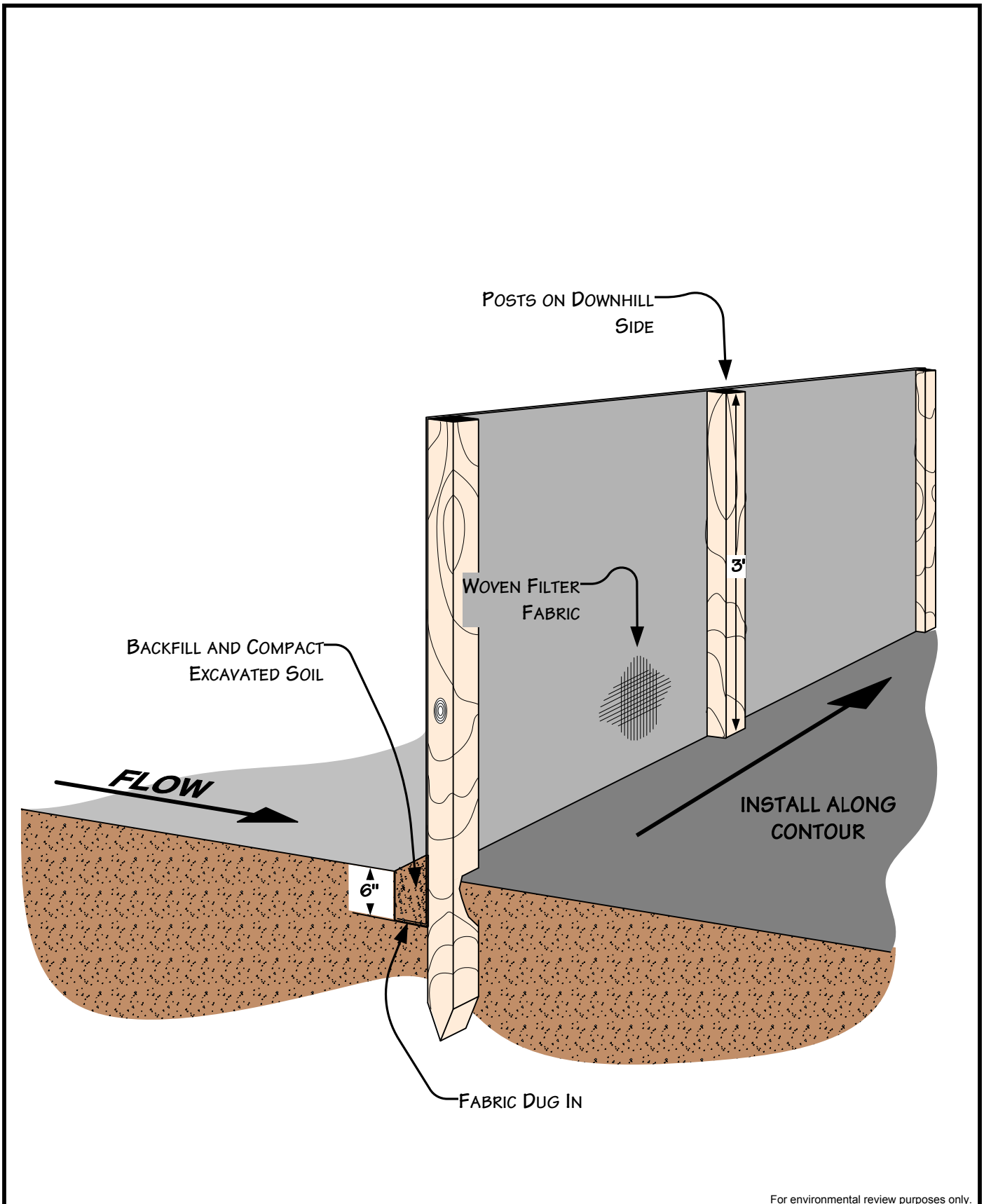
1. BERMS SHALL BE CONSTRUCTED WITH 2 TO 4 PERCENT OUTSLOPE.
2. BERMS SHALL BE OUTLETED TO WELL VEGETATED STABLE AREAS, SILT FENCES, STRAW BALES OR ROCK APRONS.
3. BERMS SHALL BE SPACED AS DESCRIBED IN CONSTRUCTION SPECIFICATIONS.
4. ADDITIONAL INFORMATION INCLUDED ON OTHER DRAWINGS.

For environmental review purposes only.



**Figure 5**  
**Environmental Mitigation Plan**  
 Typical Temporary or Permanent Berms  
 Elevation View

DATE: 5/25/2001	
REVISED: 1/16/2009	
SCALE: NTS	
DRAWN BY: KMKENDALL	
K:\1335\WI_EMP\FIGURE05.VSD	

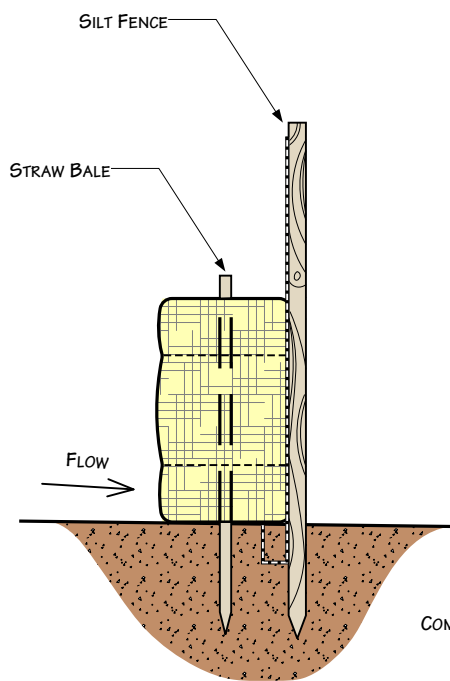
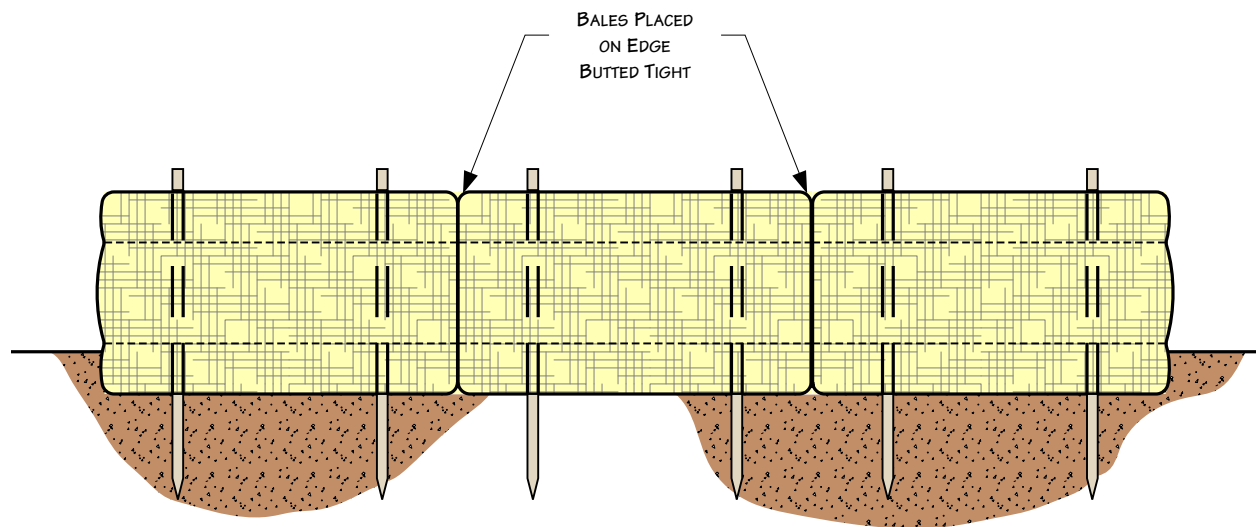


For environmental review purposes only.

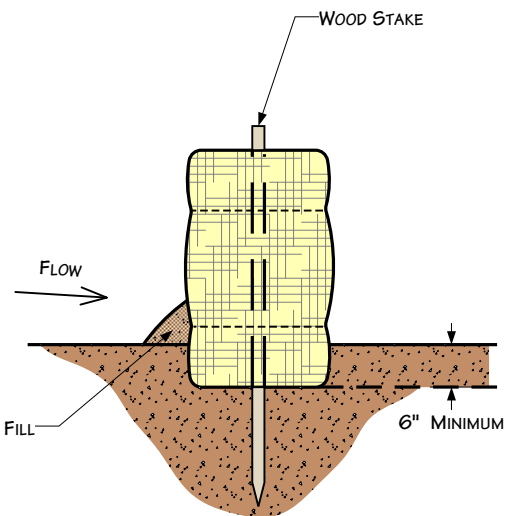


**Figure 6**  
**Environmental Mitigation Plan**  
 Typical Silt Fence Installation

DATE: 5/25/2001	
REVISED: 12/08/08	
SCALE: NTS	
DRAWN BY: KMKENDALL	
K:\1335\WI_EMP\FIGURE06.VSD	



STRAW BALES & SILT FENCE



STRAW BALES ONLY

For environmental review purposes only.



**Figure 7**  
**Environmental Mitigation Plan**  
 Typical Straw Bale Installation

DATE: 5/25/01

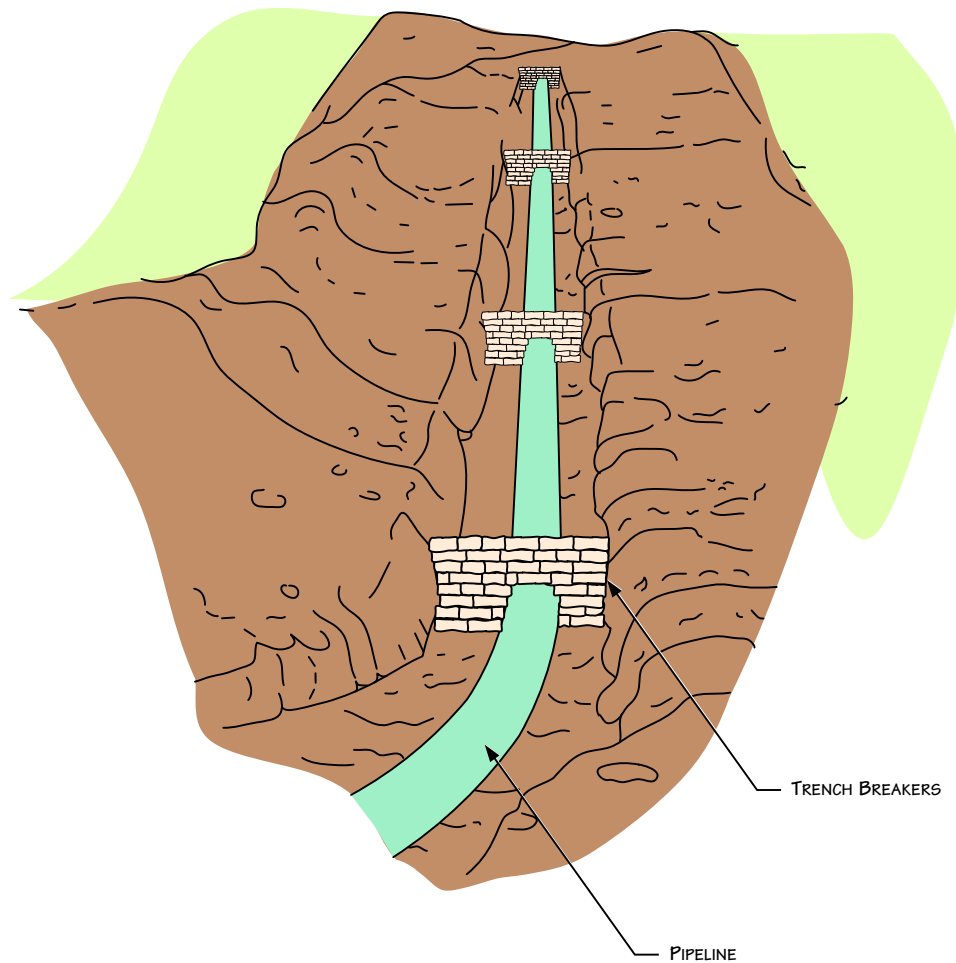
REVISED: 1/27/09

SCALE: Not to Scale

DRAWN BY: KMKENDALL

K:\335WI\_EMP\FIGURE07.VSD





NOTES

1. BAGS WILL NOT BE FILLED WITH TOPSOIL.
2. ADDITIONAL INFORMATION INCLUDED ON OTHER DRAWINGS.

For environmental review purposes only.



**Figure 8**  
**Environmental Mitigation Plan**  
 Typical Trench Breakers - Perspective View

DATE: 5/25/2001

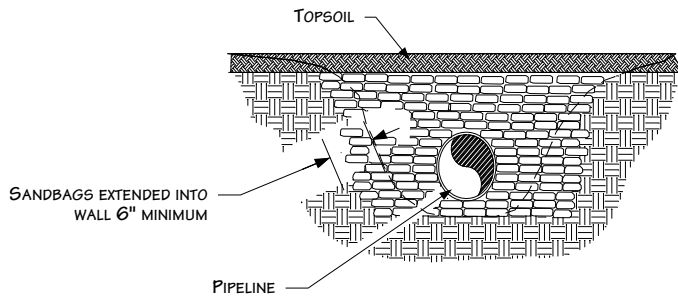
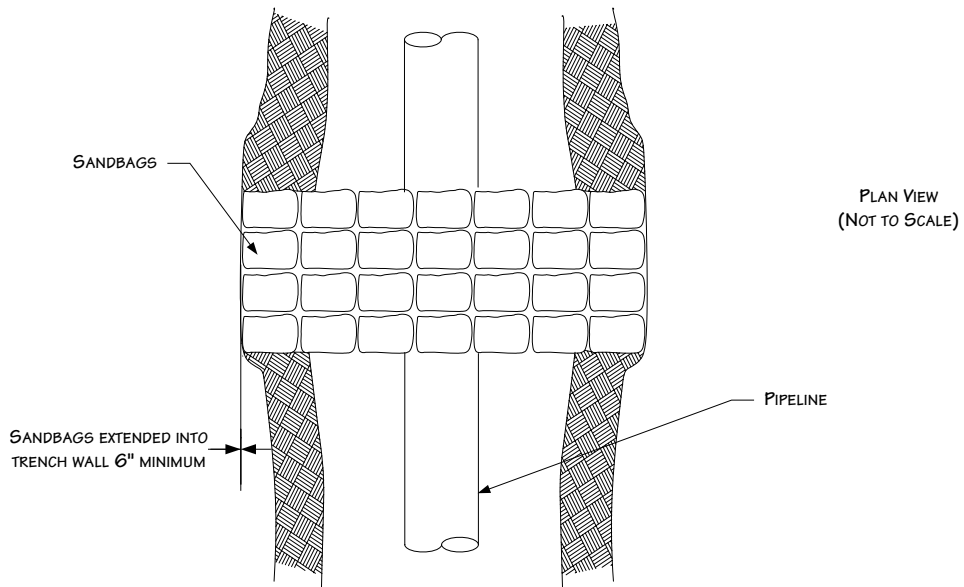
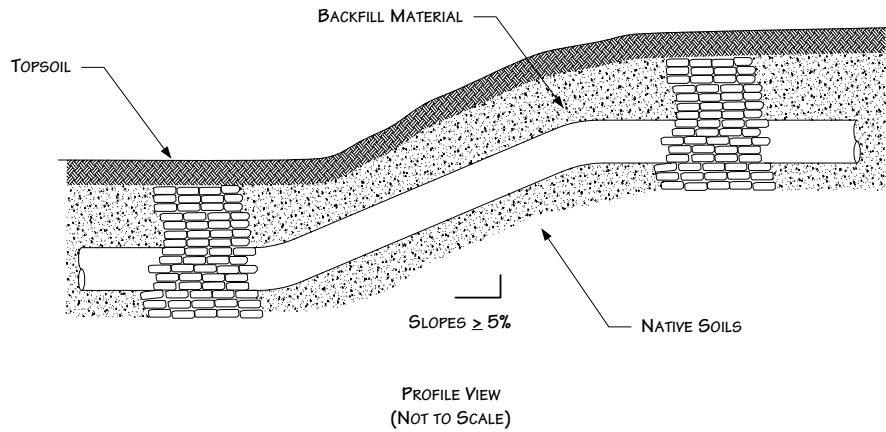
REVISED: 12/8/08

SCALE: NTS

DRAWN BY: KMKENDALL

K:\1335\WI\_EMP\FIGURE08.VSD





NOTES

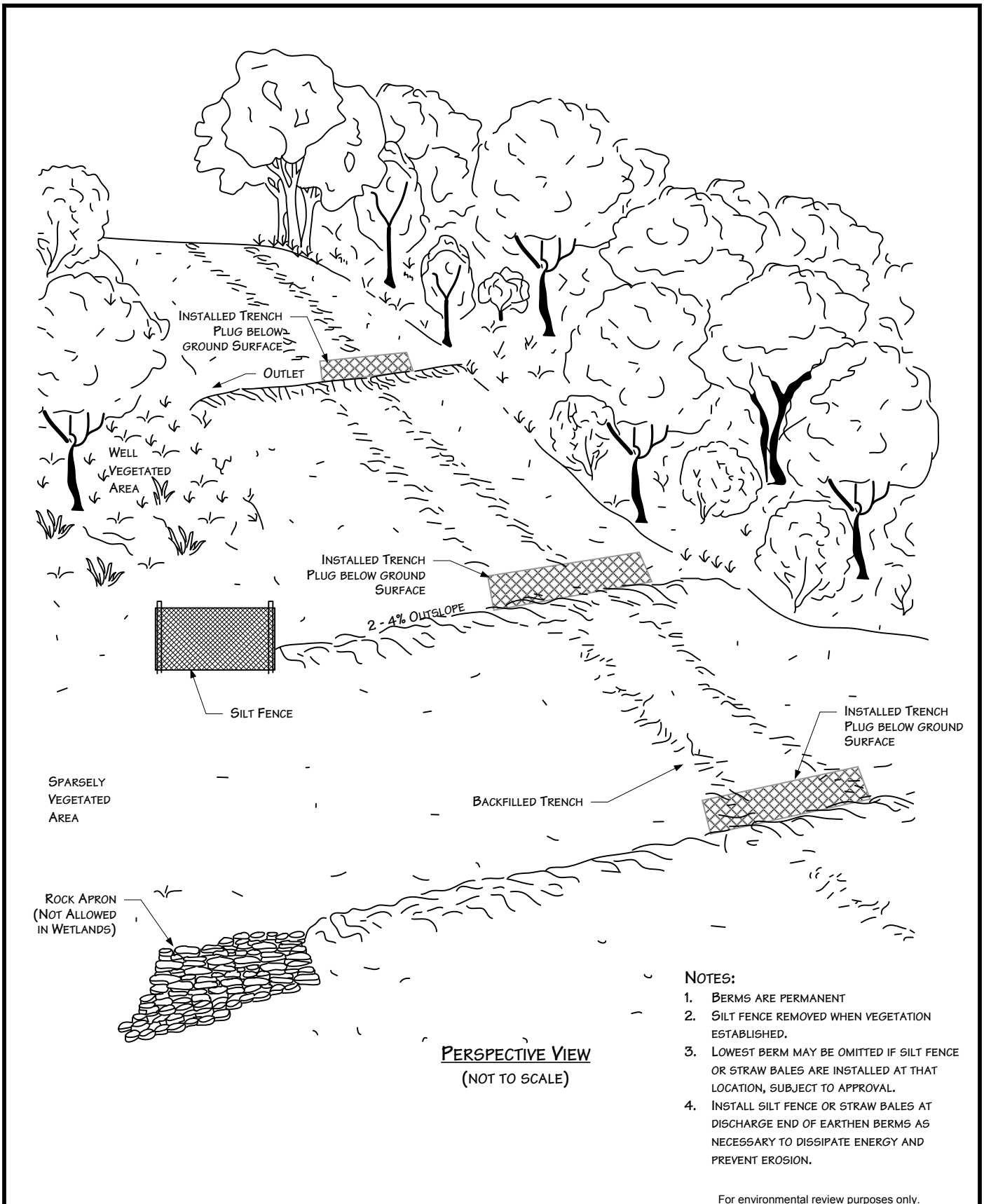
1. BAGS WILL NOT BE FILLED WITH TOPSOIL
2. ADDITIONAL INFORMATION INCLUDED ON OTHER DRAWINGS

For environmental review purposes only.



**Figure 9**  
**Environmental Mitigation Plan**  
 Typical Trench Breakers – Plan & Profile View

DATE: 11/15/2000	
REVISED: 10/24/08	
SCALE: NTS	
DRAWN BY: KMKENDALL	
K:\335WI_EMP\FIGURE09.VSD	



**NOTES:**

1. BERMS ARE PERMANENT
2. SILT FENCE REMOVED WHEN VEGETATION ESTABLISHED.
3. LOWEST BERM MAY BE OMITTED IF SILT FENCE OR STRAW BALES ARE INSTALLED AT THAT LOCATION, SUBJECT TO APPROVAL.
4. INSTALL SILT FENCE OR STRAW BALES AT DISCHARGE END OF EARTHEN BERMS AS NECESSARY TO DISSIPATE ENERGY AND PREVENT EROSION.

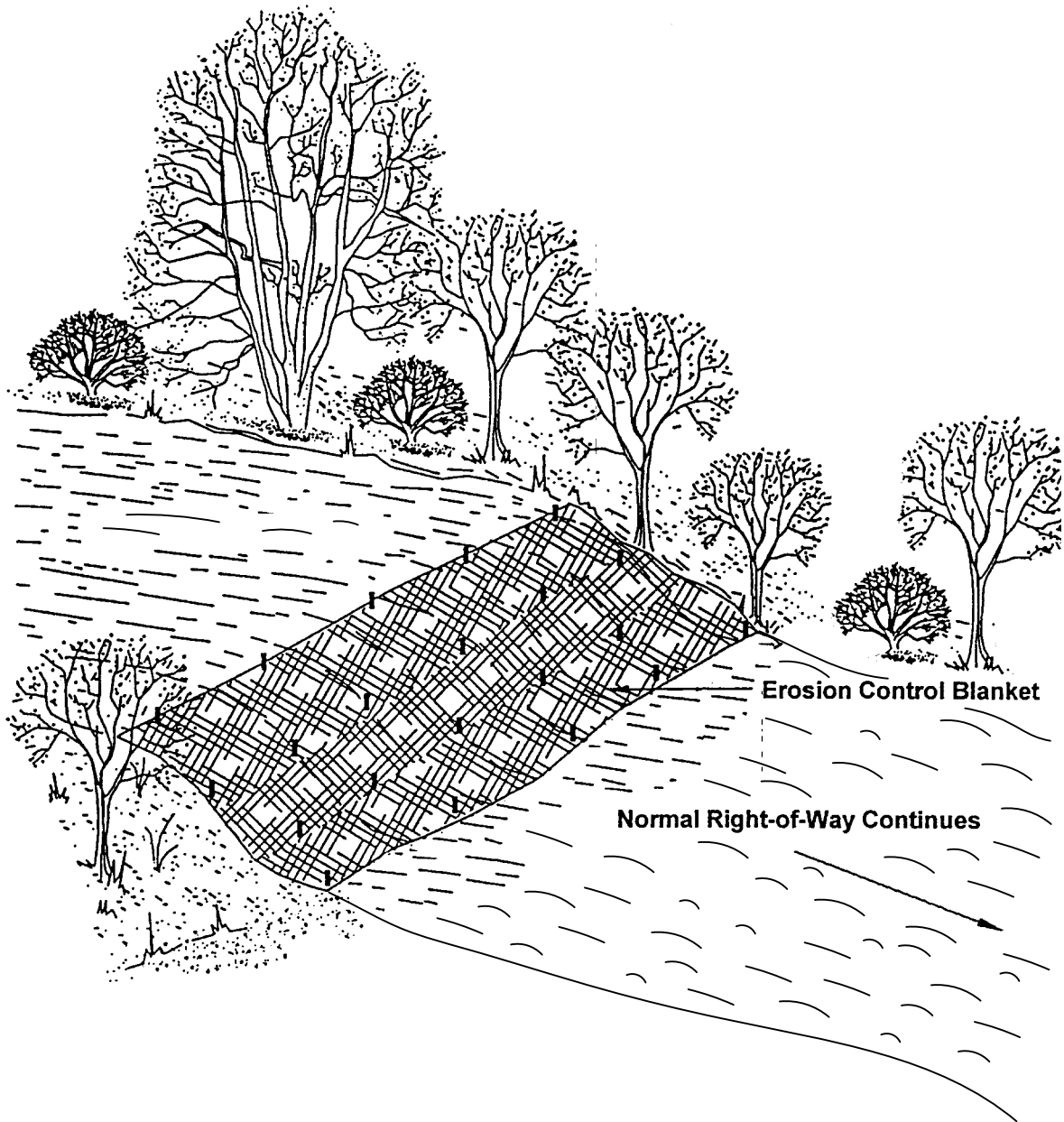
For environmental review purposes only.



**Figure 10**  
**Environmental Mitigation Plan**  
 Permanent Slope Breakers - Perspective View

DATE: 5/25/2001	
REVISED: 1/16/2009	
SCALE: NTS	
DRAWN BY: KMKENDALL	
K:\335\WI_EMP\FIGURE10.VSD	





**NOTES**

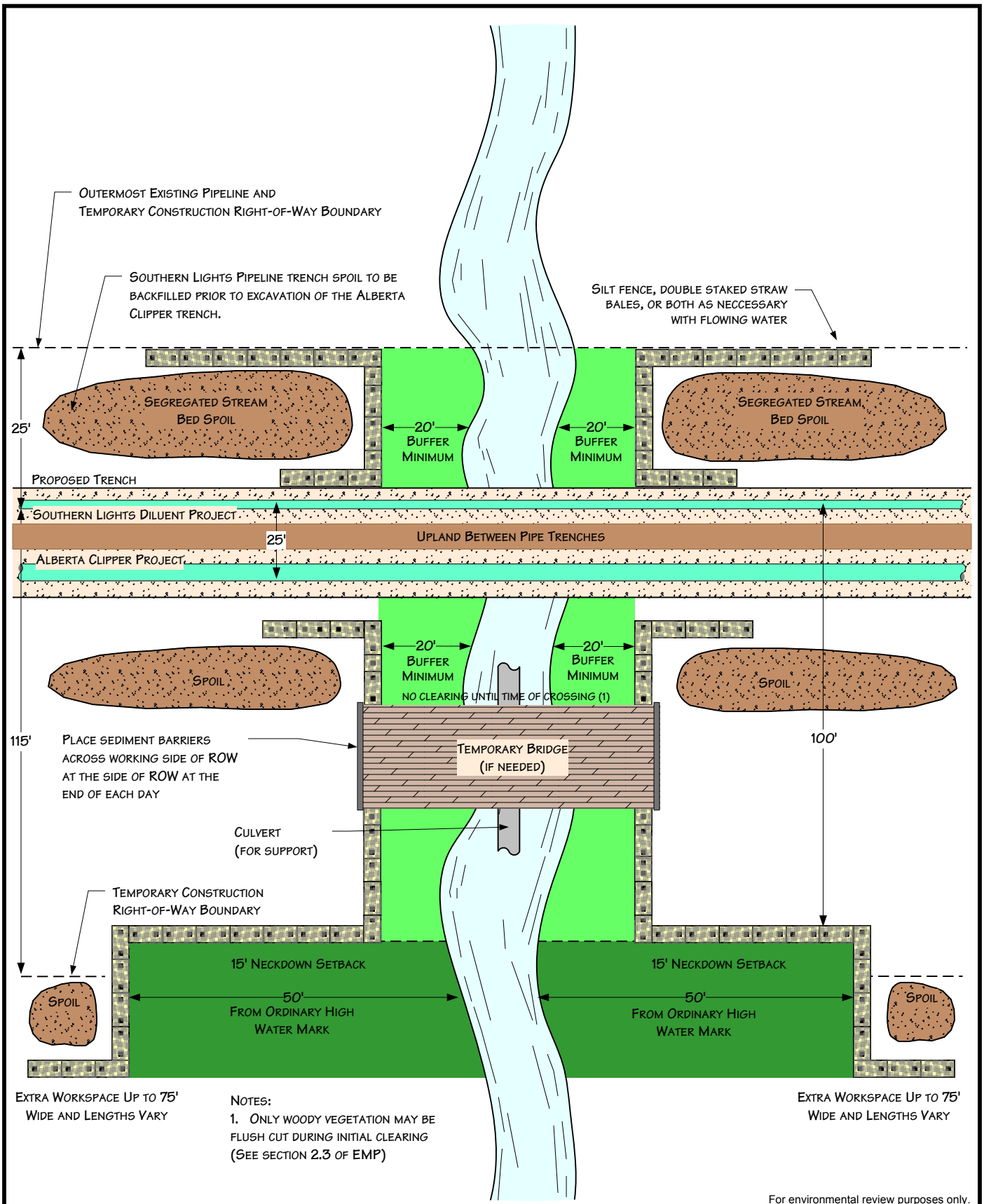
1. INSTALL EROSION CONTROL BLANKET AS PER MANUFACTURER'S SPECIFICATIONS.
2. ADDITIONAL INFORMATION INCLUDED ON OTHER DRAWINGS.

For environmental review purposes only.



**Figure 11**  
**Environmental Mitigation Plan**  
 Erosion Control Blanket - Steep Slopes ( $\geq 30\%$ )

DATE: 11/15/2000	
REVISED: 10/24/08	
SCALE: NTS	
DRAWN BY: KMKENDALL	
K:\335\WI_EMP\FIGURE11.VSD	

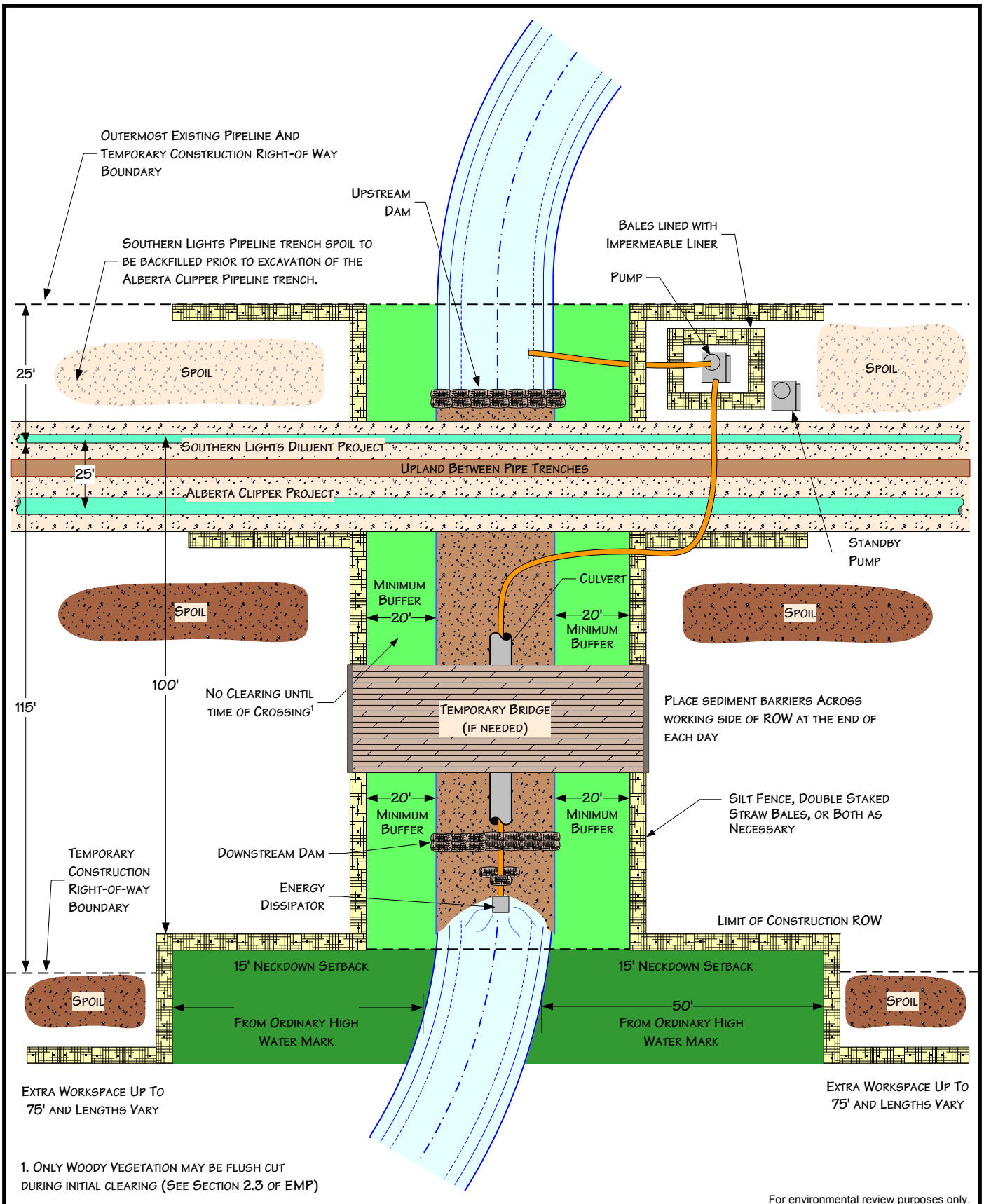


For environmental review purposes only.



**Figure 12**  
**Environmental Mitigation Plan**  
 Typical Waterbody Crossing  
 Open Cut – Wet Trench Method  
 (Wisconsin Only)

DATE: 11/29/2005	
REVISED: 1/19/09	
SCALE: NTS	
DRAWN BY: KJA	
K:\335\WI_EMP\FIGURE12.VSD	

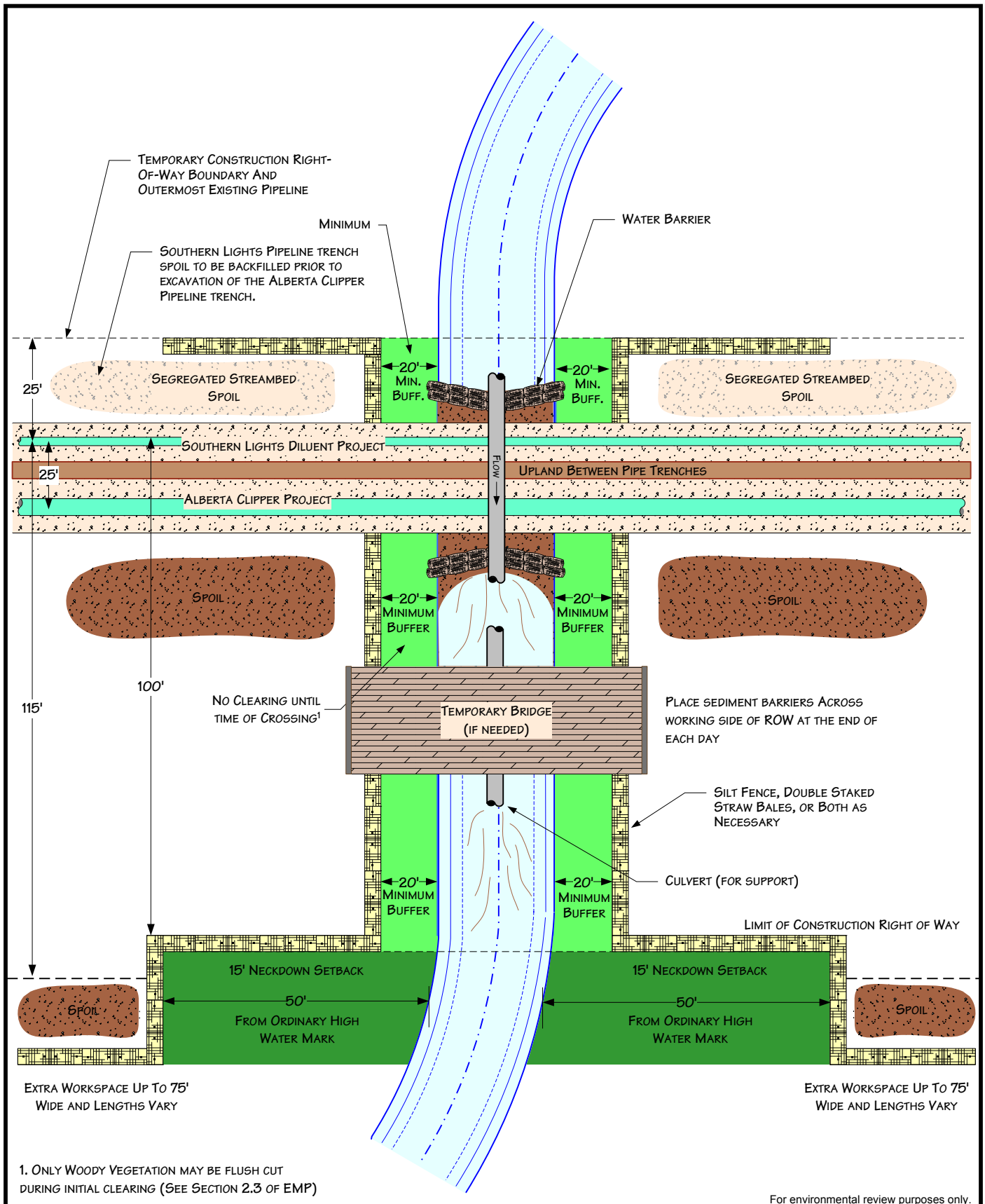


For environmental review purposes only.



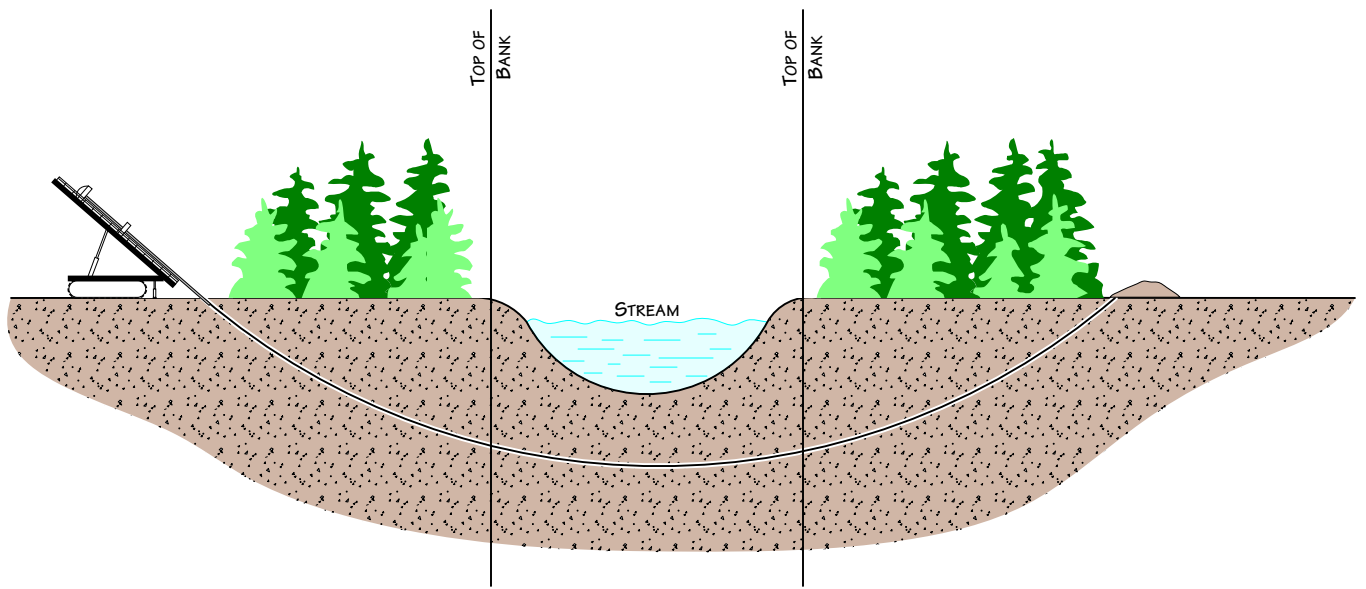
**Figure 13**  
**Environmental Mitigation Plan**  
 Typical Waterbody Crossing  
 Dam and Pump Method  
 (Wisconsin Only)

DATE: 11/29/2005	
REVISED: 1/20/09	
SCALE: NTS	
DRAWN BY: KJA	
K:\335\WI_EMP\FIGURE13.VSD	



**Figure 14**  
**Environmental Mitigation Plan**  
 Typical Waterbody Crossing  
 Flume Method  
 (Wisconsin Only)

DATE: 11/29/2005	
REVISED: 1/24/09	
SCALE: NTS	
DRAWN BY: KJA	
K1335WI_EMP/FIGURE14.VSD	



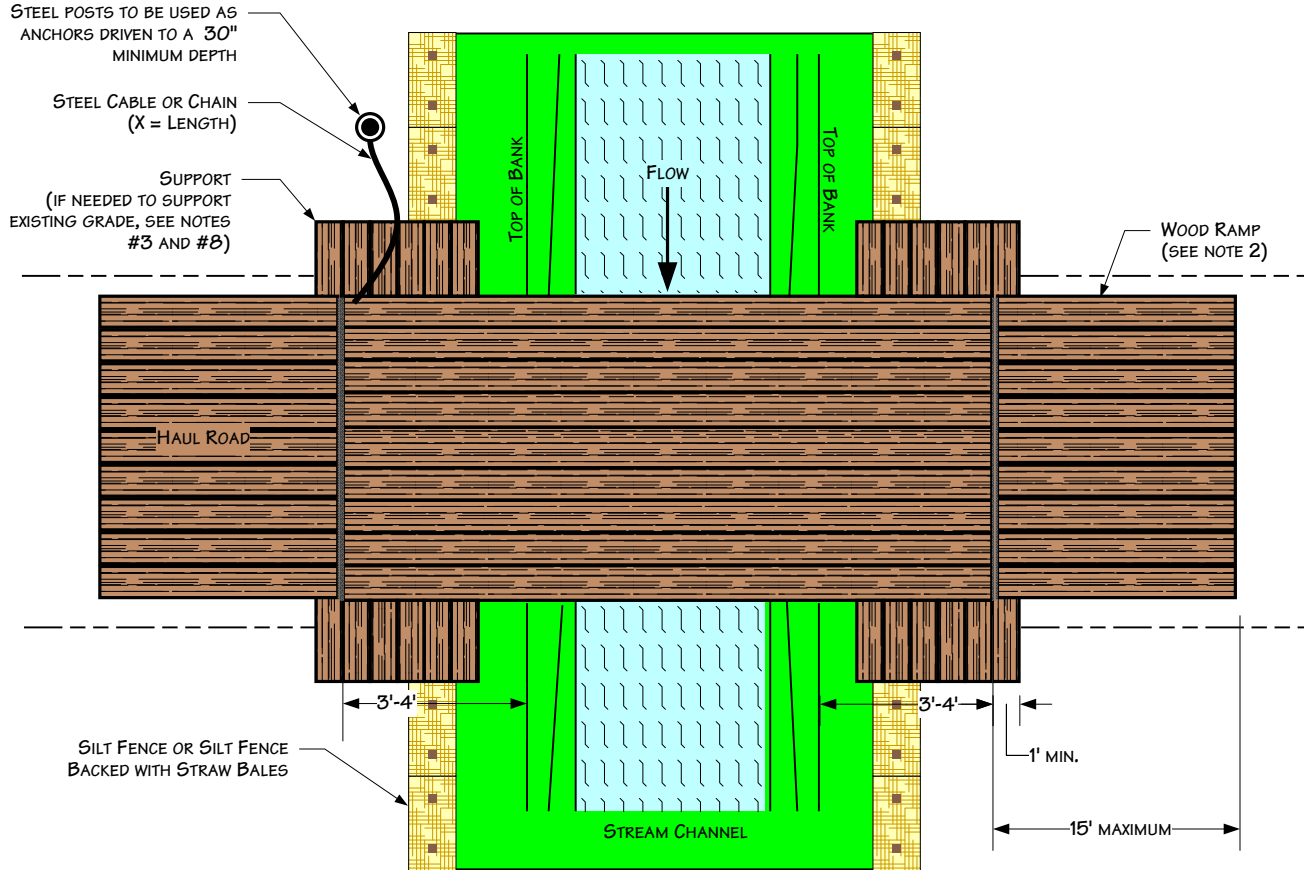
For environmental review purposes only.



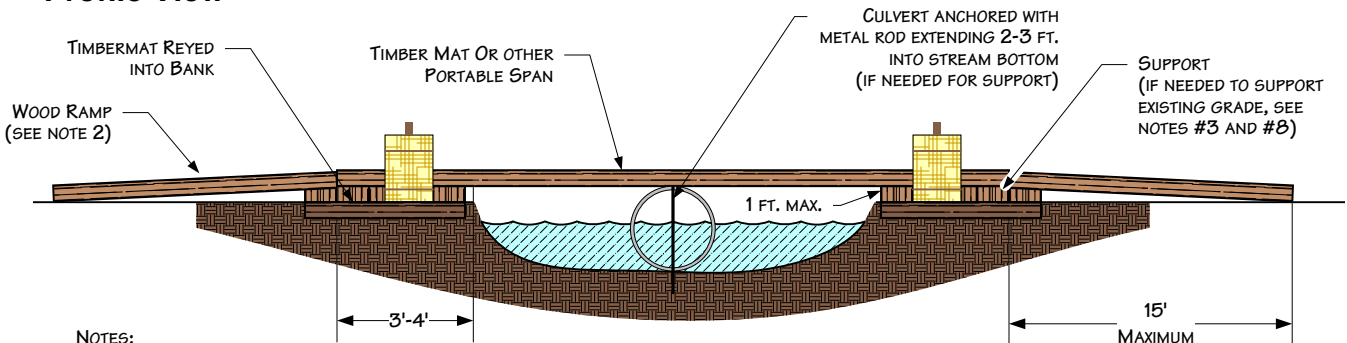
**Figure 15**  
**Environmental Mitigation Plan**  
 Typical Waterbody Crossing  
 Directional Drill Method

DATE: 7/14/2000	
REVISED: 10/24/08	
SCALE: NTS	
DRAWN BY: KMKENDALL	
K:\335\WI_EMP\FIGURE15.VSD	

### Plan View



### Profile View



**NOTES:**

1. INSPECT BRIDGE OPENING PERIODICALLY AND FOLLOWING RAINFALLS OF OVER 1/2". REMOVE ANY DEBRIS RESTRICTING FLOW AND DEPOSIT IT AT AN UPLAND SITE OUTSIDE OF FLOODPLAIN.
2. IF PHYSICAL CIRCUMSTANCES PROHIBIT WOOD OR METAL RAMPS, EARTHEN RAMPS MAY BE USED AS APPROVED.
3. INSPECT BRIDGE ELEVATION SO BRIDGE REMAINS SUPPORTED ABOVE HIGH BANK AND DOES NOT SINK INTO BANK.
4. THE CULVERT SUPPORT MUST BE ANCHORED TO THE STREAM BOTTOM AND MAY NOT BE SUPPORTED WITH FILL.
5. EARTHEN RAMP CANNOT BE TALLER THAN 1' AND CANNOT EXTEND FOR MORE THAN 15' ON EITHER SIDE OF THE CROSSING.
6. THE BRIDGE MUST SPAN FROM TOP OF BANK TO TOP OF BANK.
7. THE BRIDGE MUST BE FIRMLY ANCHORED TO PREVENT IT FROM BEING TRANSPORTED DOWNSTREAM DURING HIGH FLOW.
8. ADDITIONAL SUPPORT MUST BE ADDED ON TOP OF BANK AND UNDER SPAN IF INITIAL SUPPORT STARTS TO SETTLE.
9. EROSION AND SEDIMENTATION CONTROL MEASURES SHALL BE INSPECTED AND MAINTAINED IN ACCORDANCE WITH THE COMPANY'S ENVIRONMENTAL MITIGATION PLAN

For environmental review purposes only.



**Figure 16**  
**Environmental Mitigation Plan**  
 Typical Span Type Bridge  
 With or Without Instream Support

DATE: 3/11/2003  
 REVISED: 1/27/2009  
 SCALE: NTS  
 DRAWN BY: KMK6792

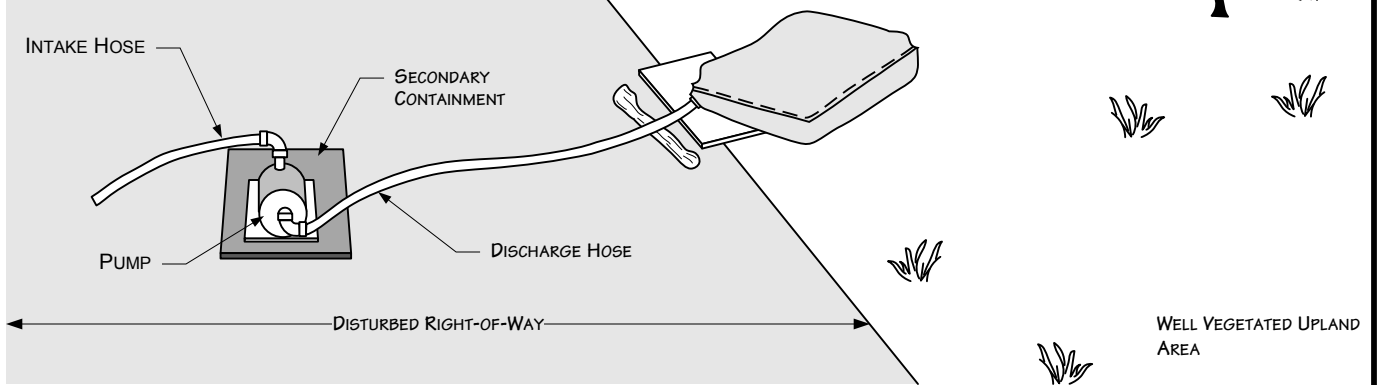


K:\335\W1\_EMP\FIGURE16.VSD

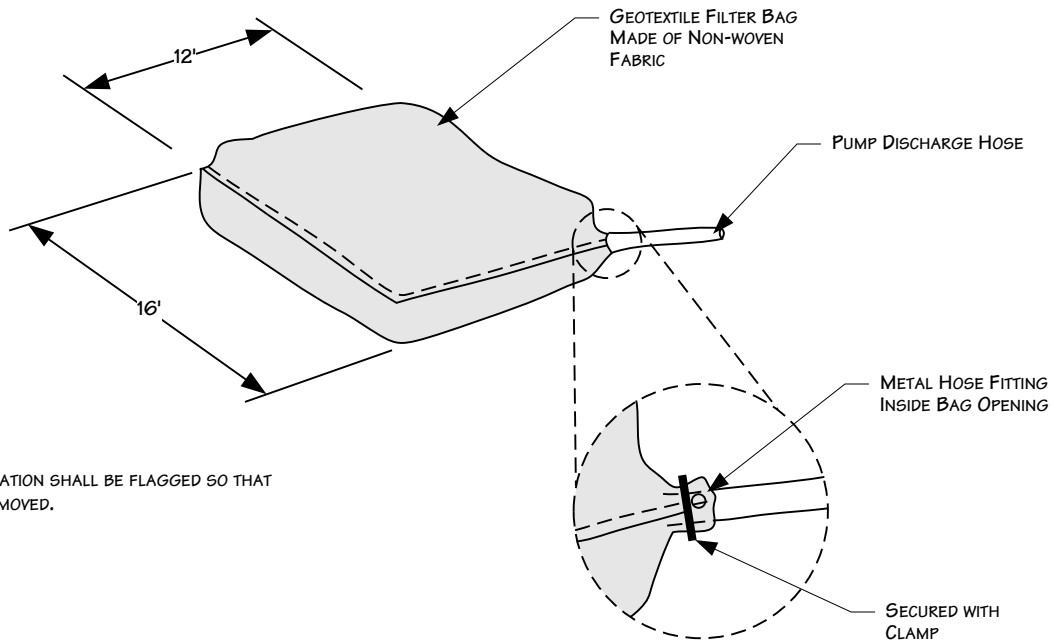
## DEWATERING DISCHARGE IN WELL VEGETATED UPLANDS

**NOTES:**

1. PUMP INTAKE HOSE MUST BE SECURED AT LEAST ONE FOOT ABOVE THE TRENCH BOTTOM.
2. DEWATER INTO GEOTEXTILE FILTER BAG OR STRAW BALE DEWATERING STRUCTURE.



## GEOTEXTILE FILTER BAG



**NOTE:**

1. FILTER BAG LOCATION SHALL BE FLAGGED SO THAT BAG CAN BE REMOVED.

For environmental review purposes only.



**Figure 17**  
**Environmental Mitigation Plan**  
**Typical Dewatering Measures**

DATE: 5/25/2001

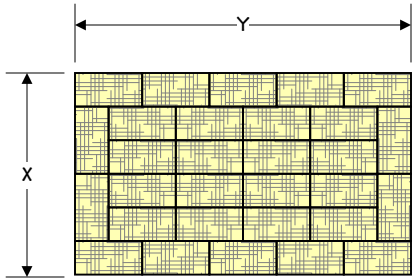
REVISED: 1/16/2009

SCALE: NTS

DRAWN BY: KMKENDALL

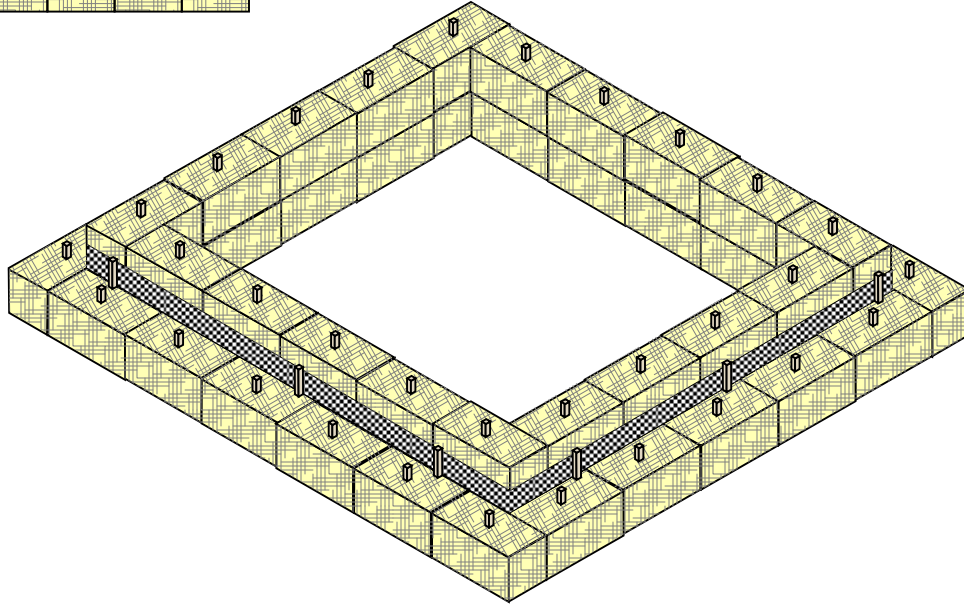
K:\335\WL\_EMP\FIGURE17.VSD



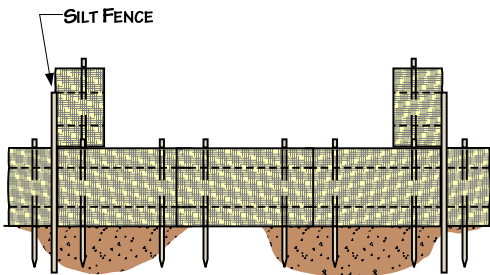


NOTES

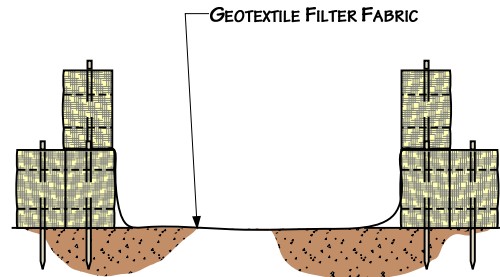
1. ARRANGE THE STRAW BALES TO THE X AND Y DIMENSIONS AS SPECIFIED BELOW.
2. IF BOTTOM OF STRUCTURE IS NOT LINED WITH STRAW BALES (OPTION 1), LINE ENTIRE STRUCTURE WITH GEOTEXTILE FILTER FABRIC.



PERSPECTIVE VIEW



OPTION 1



OPTION 2

MINIMUM SUMP DIMENSIONS (FEET)		MAXIMUM PUMPING RATE GALLONS PER MINUTE
X	Y	
10	20	300
15	20	350
20	20	400
20	25	450
25	25	500
25	30	550
30	30	660

For environmental review purposes only.



**Figure 18**  
**Environmental Mitigation Plan**  
Typical Straw Bale Dewatering Structure

DATE: 5/25/2001

REVISED: 10/24/08

SCALE: NTS

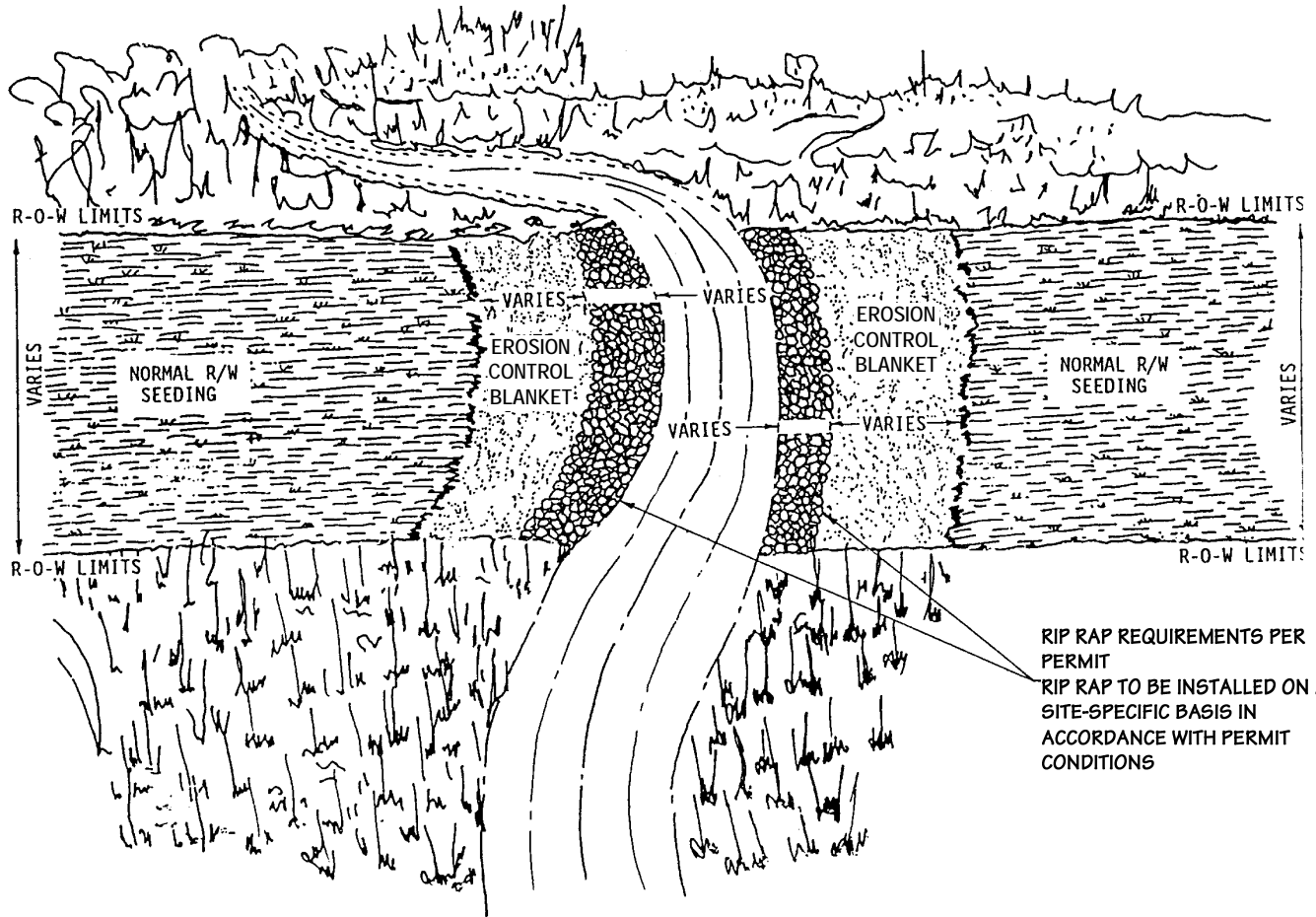
DRAWN BY: KMKENDALL

K:\335\WI\_EMP\FIGURE18.VSD





NOTE: PLACE JUTE BLANKET A MINIMUM OF ONE (1) FOOT UNDER RIP RAP. EXTEND JUTE BLANKET FROM MEAN HIGH WATER LEVEL TO SEVERAL FEET BEHIND HIGH BANK.



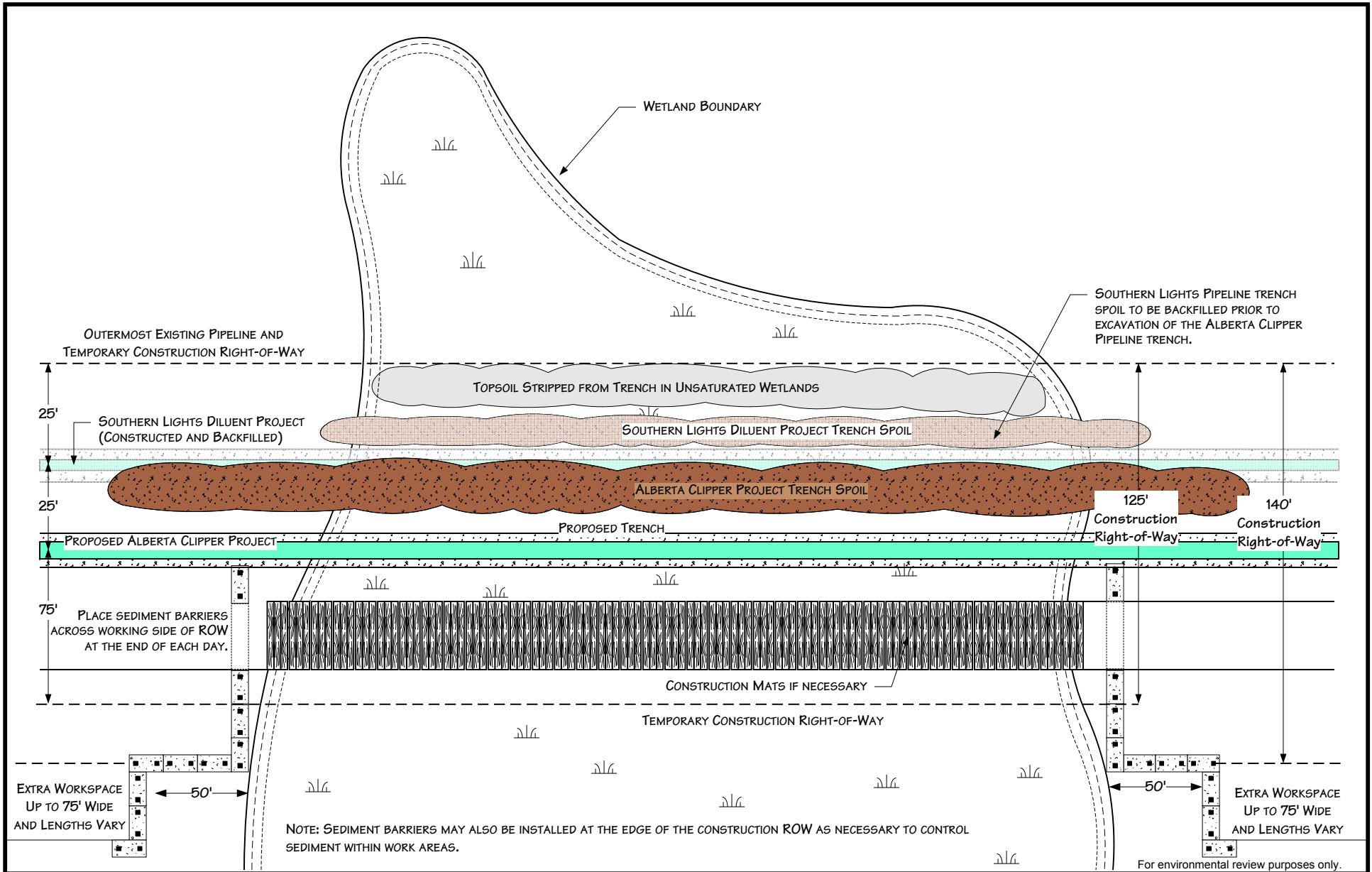
For environmental review purposes only.



**Figure 19**  
**Environmental Mitigation Plan**  
 Typical Final Stream Bank Stabilization  
 Rip Rap & Erosion Control

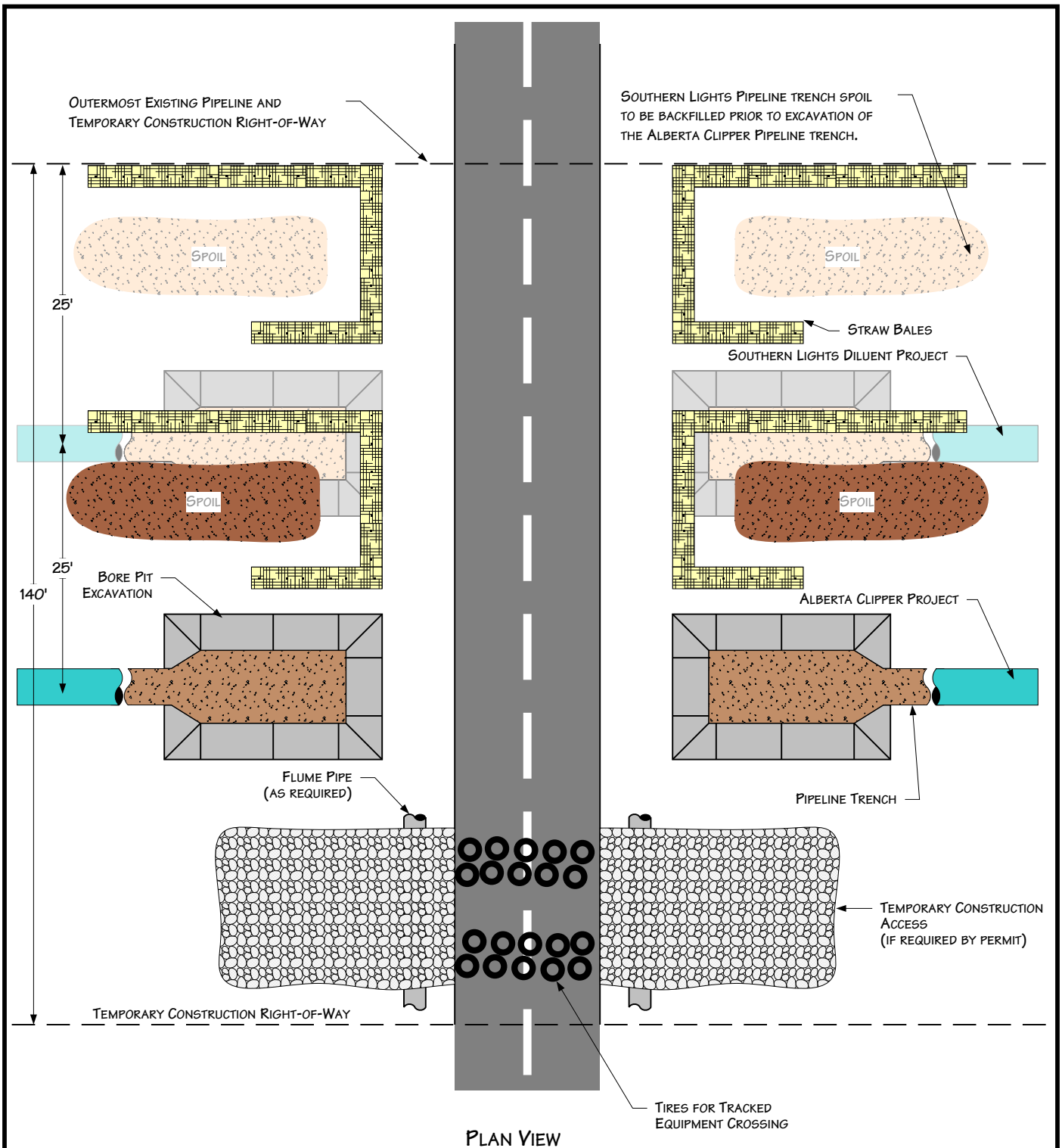
DATE: 7/19/2000  
 REVISED: 1/16/2009  
 SCALE: NTS  
 DRAWN BY: KMKENDALL  
 K1335WI\_EMP\FIGURE19.VSD





**Figure 20**  
**Environmental Mitigation Plan**  
 Typical Wetland Crossing Method  
 (Wisconsin Only)

DATE: 5/25/2001	
REVISED: 1/20/2009	
SCALE: NTS	
DRAWN BY: KMKENDALL	
K:\335WI_EMP\FIGURE20.VSD	



PLAN VIEW

NOTES

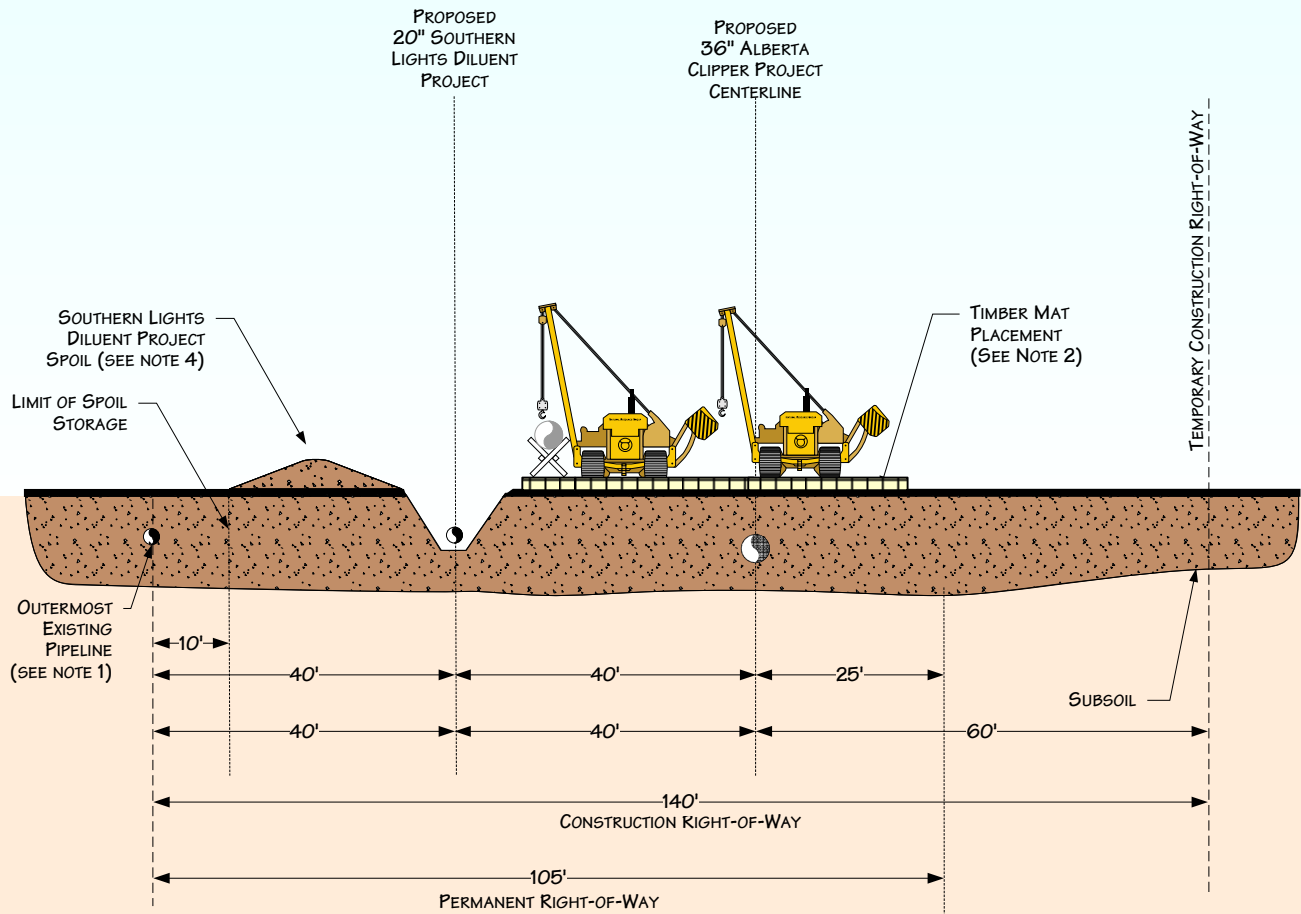
1. PROCEDURES SHOWN IN THIS DRAWING APPLY TO IMPROVED ROADS.
2. ROADS MUST BE CLEANED AFTER EQUIPMENT CROSSES AND DIRT PLACED IN SPOIL CONTAINMENT AREAS.
3. TEMPORARY ACCESS MATERIALS MUST BE REMOVED UPON PROJECT COMPLETION.
4. ADDITIONAL INFORMATION INCLUDED ON OTHER DRAWINGS OR PERMITS.
5. CONSTRUCTION AREAS LOCATED OUTSIDE ROAD ROW.

For environmental review purposes only.



**Figure 21**  
**Environmental Mitigation Plan**  
 Typical Improved Road Crossing  
 Directional Bore Method

DATE: 7/13/1999	
REVISED: 1/28/2009	
SCALE: NTS	
DRAWN BY: KMKENDALL	
K:\335\WI_EMP\FIGURE21.VSD	



**PROFILE**

**NOTES:**

1. THE OFFSET FROM THE OUTERMOST EXISTING PIPELINE WILL BE 40' FOR MOST LOCATIONS BUT MAY BE INCREASED OR DECREASED DEPENDING ON THE SITE SPECIFIC CONSTRUCTION REQUIREMENTS.
2. TIMBER MATS USED IN CONSTRUCTION OF SOUTHERN LIGHTS DILUENT PIPELINE WILL BE SLID OVER AND REUSED FOR THE CONSTRUCTION OF THE ALBERTA CLIPPER PIPELINE.
3. BECAUSE OF THE EXTENSIVE NATURE OF WETLANDS CROSSED AND THE LACK OF SUITABLE ROADS FOR MOVE-AROUNDS, ALL CONSTRUCTION EQUIPMENT MAY NEED TO TRAVERSE THE RIGHT-OF-WAY USING A TIMBER MAT PASSING LANE DESIGNED TO ACCOMMODATE CONSTRUCTION TRAFFIC.
4. SOUTHERN LIGHTS PIPELINE TRENCH SPOIL TO BE BACKFILLED PRIOR TO EXCAVATION OF THE ALBERTA CLIPPER PIPELINE TRENCH.

For environmental review purposes only



**Figure 22**  
**Environmental Mitigation Plan**  
 Right-of-Way Configuration  
 Summer Saturated Wetland Construction  
 20" Southern Lights Construction

DATE: 5/23/2007

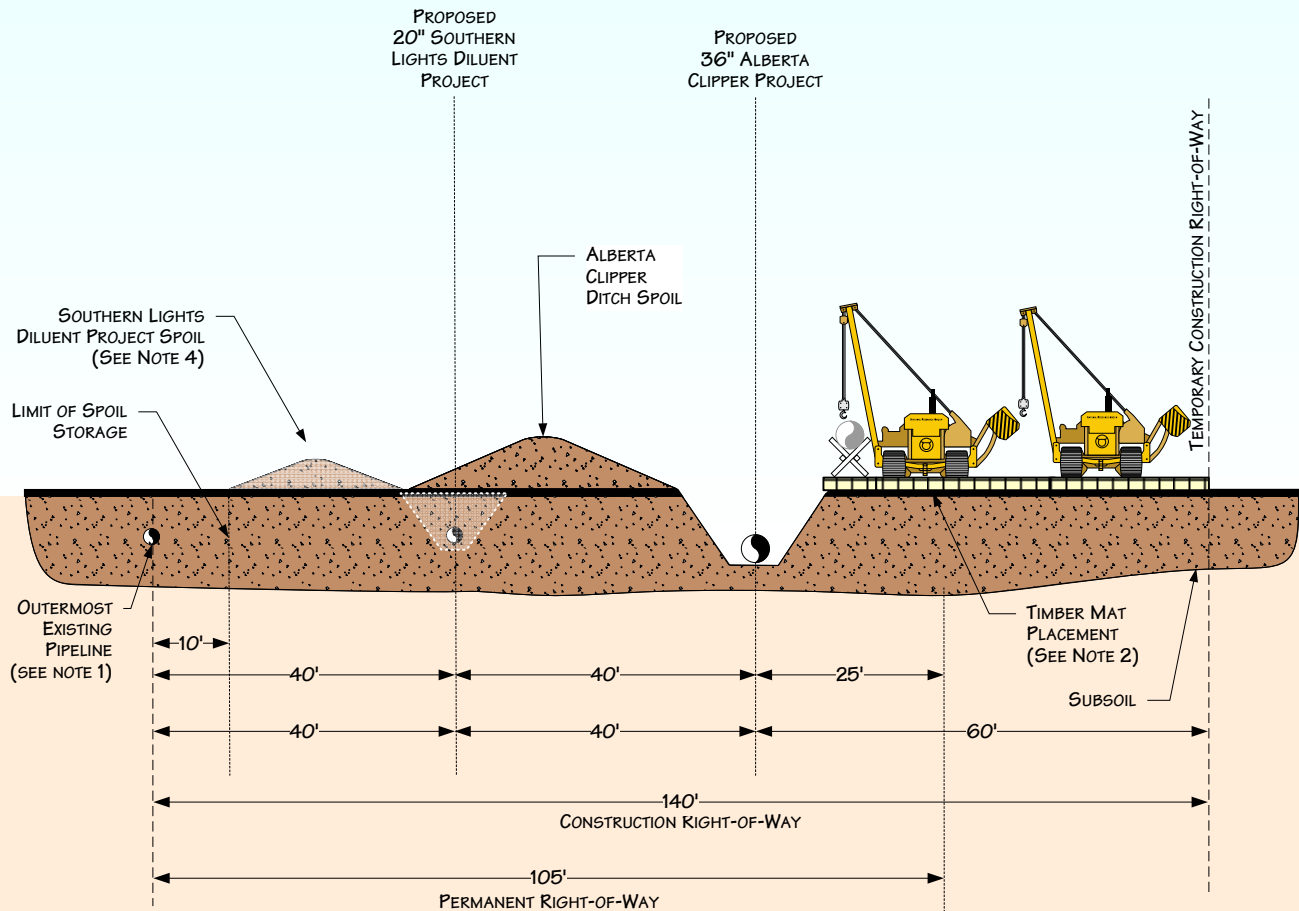
REVISED: 1/19/09

SCALE: NTS

DRAWN BY: AKR

K:\335\WI\_EMP\FIGURE22.VSD





**PROFILE**

**NOTES:**

1. THE OFFSET FROM THE OUTERMOST EXISTING PIPELINE WILL BE 40' FOR MOST LOCATIONS BUT MAY BE INCREASED OR DECREASED DEPENDING ON THE SITE SPECIFIC CONSTRUCTION REQUIREMENTS.
2. TIMBER MATS USED IN CONSTRUCTION OF SOUTHERN LIGHTS DILUENT PIPELINE WILL BE SLID OVER AND REUSED FOR THE CONSTRUCTION OF THE ALBERTA CLIPPER PIPELINE.
3. BECAUSE OF THE EXTENSIVE NATURE OF WETLANDS CROSSED AND THE LACK OF SUITABLE ROADS FOR MOVE-AROUNDS, ALL CONSTRUCTION EQUIPMENT MAY NEED TO TRAVERSE THE RIGHT-OF-WAY USING A TIMBER MAT PASSING LANE DESIGNED TO ACCOMMODATE CONSTRUCTION TRAFFIC.
4. SOUTHERN LIGHTS PIPELINE TRENCH SPOIL TO BE BACKFILLED PRIOR TO EXCAVATION OF THE ALBERTA CLIPPER PIPELINE TRENCH.

For environmental review purposes only



**Figure 23**  
**Environmental Mitigation Plan**  
 Right-of-Way Configuration  
 Summer Saturated Wetland Construction  
 36" Alberta Clipper Construction

DATE: 5/23/2007

REVISED: 1/19/09

SCALE: NTS

DRAWN BY: AKR

K:\335\WI\_EMP\FIGURE23.VSD



*This page left intentionally blank.*