

Appendix J

Geotechnical Basis of Design Report

Terminal 117 Cleanup Design
Sediment and Upland Areas

Geotechnical Basis of Design Report

August 2012



Prepared by:



Jacobs Associates
1109 First Avenue, Suite 501
Seattle, WA 98101

Distribution

To: Mike Byers, P.E.
Crete Consultants

Jamie Stevens, P.E.
Crete Consultants

From: Carol Ravano, P.E.
Jacobs Associates

Prepared By: Carol Ravano, P.E.
Jacobs Associates

Lynn Salvati, P.E., Ph.D.
Jacobs Associates

Steve Guarente
Jacobs Associates

Reviewed By: Frank Pita, P.E.
Jacobs Associates

Table of Contents

1	Introduction	1
	1.1 Introduction	1
	1.2 Project Description	1
	1.3 Scope of Work.....	1
2	Site and Subsurface Conditions.....	3
	2.1 Site Description	3
	2.2 Topography	4
	2.3 Geologic Setting.....	4
	2.4 Subsurface Exploration	4
	2.5 Subsurface Soil Profile and Sections.....	4
	2.6 Geologic Soil Units.....	5
	2.7 Groundwater Characteristics	7
3	Engineering Soil Properties	9
4	Geotechnical Design and Construction Considerations	10
	4.1 Temporary Sheet Pile Wall	10
	4.2 Temporary Slopes.....	12
	4.3 Temporary Shoring Design Recommendations.....	13
	4.4 Ground Deformation and Performance Monitoring.....	13
	4.5 Dewatering Recommendations.....	15
5	Closure.....	16
6	References.....	17

List of Tables

Table 1 Locations and Estimated Flows at Observed Groundwater Seeps
Table 2 Seepage Measurements from Previous Site Studies
Table 3 Engineering Soil Properties
Table 4 WISHA Slope Requirements
Table 5 Performance Monitoring and Action Level Recommendations

List of Figures

Figure 1 Site and Exploration Plan
Figure 2 Plan and Profile Legend
Figure 3 Subsurface Profile – Profile A
Figure 4 Subsurface Profile - Section B
Figure 5 Subsurface Profile – Section C
Figure 6 Sheet Pile Wall Plan and Profile
Figure 7 Sheet Pile Wall Details

List of Appendices

Appendix A- Groundwater Elevation Maps
Appendix B- WISHA Sloping and Benching Requirements
Appendix C-Excavation Plan
Appendix D-Soldier Pile Wall Design Calculations

1 Introduction

1.1 Introduction

The purpose of this report is to provide to Crete Consulting, Inc. a Basis of Design (BOD) for the geotechnical considerations of the Port of Seattle Terminal 117 Cleanup Design-Sediment and Upland Areas project (Project). This report provides a summary of the geotechnical work completed for the Project.

Elevations (El.) are referenced to the Mean Lower Low Water (MLLW). The basis of bearings is the Washington State Coordinate System of 1983, 1991 adjustment (NAD83/91).

1.2 Project Description

Terminal 117 (T-117) is an early action area (EAA) within the Lower Duwamish Waterway (LDW) Comprehensive Environmental Response, Compensation, and Liability Act (CERCLA; Superfund) site, in Seattle, Washington. It was selected as an EAA to address polychlorinated biphenyl (PCB) contamination in sediment. EPA approved an engineering evaluation/cost estimate (EE/CA; Windward et al. 2010) prepared by the Port of Seattle (Port) and City of Seattle (City) in September 2010. The approved removal action includes the removal and disposal of contaminated soil and sediment from approximately two acres of the LDW estuary, three acres of T-117 upland (formerly an industrial facility), and ten acres of specified adjacent streets, rights-of-ways, and residential yards. Jacobs Associates involvement focuses on the geotechnical considerations of the sediment and upland portions of the project only.

The T-117 EAA is situated on the western bank of the LDW, between River Mile (RM) 3.5 and RM 3.7 (relative to the southern tip of Harbor Island). The EAA is located approximately 6 miles south of the Seattle downtown area and is across the LDW from the Boeing Plant 2/Jorgensen Forge EAA. The T-117 Upland Area is located within a narrow strip of unincorporated King County that lies between the LDW to the east and the South Park neighborhood of Seattle to the west. The T-117 Upland Area is located at 8700 Dallas Avenue S and is immediately south/upstream of the South Park Bridge.

Approximately 7,700 cubic yards (cy) of sediment will be dredged from the T-117 Sediment Area to a final elevation ranging from El. -2 feet near the bank to El. -14 feet near the South Park Marina (SPM). Upland soils (approximately 30,000 cy) will be excavated from the site, and the site will be backfilled to El. 14 feet. Removal required in the upland portion of the site includes excavations that extend from the current ground surface elevation at around El. 20 to 22 feet down to approximately El. 3 feet, with the majority of the site being excavated down to around El. 9 to 13 feet. Given the depths of the upland excavation, excavation supports and/or a shoreline barrier may be needed to allow excavation of contaminated upland soils.

1.3 Scope of Work

The scope of work completed by Jacobs Associates for this report is as follows:

- Review of previously published reports for the Project.
- Review of readily available documents on other projects in the area.
- Perform field reconnaissance and subsurface exploration. The subsurface exploration consisted of:

- Six borings and eight CPTs.
- Three of the borings were completed from a barge on the LDW, and three borings were completed on land, in the upland site area.
- Five of the CPTs were completed from the barge in the sediment area, and three were performed on land in the upland area.
- Perform geotechnical laboratory testing on selected samples.
- Prepared a “Geotechnical Data Report (GDR)”, dated September 2011, summarizing the procedures and results of the geotechnical field exploration and geotechnical laboratory testing programs completed to evaluate the subsurface conditions at this site in order to develop design recommendations for excavation supports and a shoreline barrier. The GDR includes the boring and CPT logs, the Geotechnical Laboratory test results, and exploration borings completed by others.
- Prepared a “Geotechnical Input Memorandum”, dated 12 September 2011, which provided Jacobs Associates geological and geotechnical input for the 30% Design Report.
- Prepared a “Dewatering Flow Estimates Memorandum, dated 4 November 2011.
- Prepared a “Shoring Design Calculation Summary Memorandum”, dated 12 December 2011.
- Prepared a “WISHA Requirements for Temporary Slopes Memorandum”, dated 30 December 2011, which addressed the temporary cut slopes on the site.
- Prepared a “Settlement and Performance Monitoring Memorandum”, dated 30 December 2011, which provided recommendations for settlement and performance monitoring for the Project.
- Prepared 60% design specifications.
- Prepared this comprehensive “Geotechnical Basis of Design Report”.

2 Site and Subsurface Conditions

This section provides a discussion of the general surface and subsurface conditions relevant to the removal action. Interpretations of the site conditions are based on the results of our review of available information including results from previous geotechnical investigations at the site, site reconnaissance, and information collected during our subsurface exploration.

2.1 Site Description

Much of the PCB contamination at the site is associated with historical industrial activities that involved asphalt manufacturing in the T-117 Upland Area. During manufacturing activities, PCBs were released to the surrounding environment. Asphalt manufacturing activities ceased in the early 1990s, and the former asphalt plant, tanks, and some contaminated soil were removed in 1996 and 1997. The Port acquired the former asphalt plant property in 2000. Currently, the T-117 Upland Area is fenced, secured, and vacant. The T-117 EAA and vicinity are zoned as mixed-use for residential, commercial, and industrial activities). Current land use in the area is primarily manufacturing, commercial, and residential.

The T-117 Upland Area is located within a narrow strip of unincorporated King County that lies between the LDW to the east and the South Park neighborhood of Seattle to the west. The boundary between unincorporated King County and the City of Seattle runs along the eastern side of Dallas Avenue S, starting at the southern property boundary, and terminates at the intersection of 14th Avenue S and Dallas Avenue S. The T-117 Sediment Area is in the Duwamish Commercial Waterway District.

The following properties are adjacent to the Upland Area.

- The South Park Marina (SPM) is primarily used for boat storage and maintenance, as well as the moorage of live-aboard and recreational vessels; the marina is in unincorporated King County jurisdiction. The upland portion of the marina is currently owned and operated by South Park Marina Ltd. Partners. The in-water portion of the marina lies within the Duwamish Commercial Waterway District.
- The former Basin Oil plant (a used oil and antifreeze processing facility that ceased operations in 2004) at 8661 Dallas Avenue S in the City of Seattle is currently owned by Basin Oil. This property was residential prior to being used for industrial purposes.
- A portion of the Boeing South Park facility, which is currently owned by The Boeing Company and is primarily used as a training center, is located immediately south of T-117. The Boeing facility is in the City of Seattle jurisdiction.

The T-117 Sediment Area is the aquatic portion of the T-117 EAA. Located within the LDW, it is approximately 1.4 acres in size and consists primarily of intertidal sediment with some subtidal sediment. The Sediment Area is bordered by the marina to the north, by the LDW to the south, by the LDW navigation channel to the east, and by the T-117 Upland Area to the west.

Abandoned manmade structures and debris are buried across the EAA and are exposed along the shoreline. These buried obstructions are expected to be encountered in excavations within the fill and alluvial deposits.

2.2 Topography

The T-117 EAA is located along the western shoreline of the LDW, southwest of downtown Seattle in the South Park neighborhood. The T-117 Upland Area is relatively flat with an elevation that ranges from approximately El. 13.8 feet at the top of the bank to approximately El. 23 feet along the property boundaries at Dallas Avenue S and the SPM. The Sediment Area extends from the top of the bank at El. 13.8 feet into the LDW 60 to 80 feet to El. -10 feet.

2.3 Geologic Setting

The area is underlain by sedimentary bedrock of the Oligocene-age Blakely Formation, which outcrops on the low hills to the southwest of the site (Troost et al. 2004). Bedrock was encountered in borings on Boeing property adjacent to the south side of the project area. The sedimentary bedrock (sandstone, conglomerate, and minor siltstone) is mantled by Quaternary-age Vashon till consisting of a compact diamict of silt, clay, sand, and gravel that glacially transported and deposited under ice.

2.4 Subsurface Exploration

The geotechnical subsurface exploration program for the Project included six mud rotary soil borings and eight cone penetration tests (CPTs) across the T-117 site (Upland Area) and within the Lower Duwamish Waterway along the T-117 shoreline (Sediment Area). Figure 1 shows the site and exploration plan, and Figure 2 provides the plan and profile legend. The purpose of the exploration program was to obtain subsurface data to interpret the geotechnical and geologic conditions at the site. The “Geotechnical Data Report (GDR)”, produced by JA and dated September 2011, outlines the subsurface exploration program and the geotechnical laboratory testing completed for this project; the GDR includes the boring and CPT logs, the results of the geotechnical laboratory tests, and the boring logs of some previous explorations by others. This information will not be repeated in this report. Previous site investigations, including CPTs, soil borings, sediment vibracores, and a monitoring well installation, were also used to evaluate site subsurface conditions. The locations of these investigations are also shown on Figure 1.

2.5 Subsurface Soil Profile and Sections

Current and existing subsurface information for the T-117 site was compiled and interpreted to develop profiles of subsurface conditions across the project area. Based on this information, geologic interpretation in an earlier report (LDW remedial investigation, Windward 2010), and published geologic mapping; site geologic units were identified and a geologic profile and two geologic sections, which are provided as Figures 3, 4, and 5, were created for use in the geotechnical engineering design.

Five geologic soil units, which are described in Section 2.6, were identified within T-117 subsurface investigations: fill deposits, recent organic deposits, younger alluvium, older alluvium, and glacial deposits. Fill was placed on the entire Upland Area to elevate and flatten the site. Fill was also placed along the adjacent shoreline to enlarge the site. An abandoned meander along the north edge of the site near the marina was backfilled during urbanization. Recent organic deposits form discontinuous pockets across the Upland Area and may have formed in abandoned meanders and in shallow channels and depressions across the Sediment Area. These deposits form a layer that mantles the younger alluvium in the Sediment Area. Quaternary alluvium, consisting of younger fluvial deposits over older estuarine deposits, overlies the irregular upper contact of the glacial deposits; these combined deposits thicken toward the southeast across the project area. Glacial deposits are relatively shallow along the north side of the project area, but increase in depth to the southeast.

2.6 Geologic Soil Units

As described in the previous section, five geologic soil units were identified within T-117 subsurface investigations: fill deposits, recent organic deposits, younger alluvium, older alluvium, and glacial deposits. These five units represent soil materials with similar geologic origin and engineering properties. Sedimentary bedrock was not encountered within any of the subsurface investigations, but is interpreted to be present at an unknown depth beneath the site. Pieces of rock, which were thought to be from the same formation as the bedrock encountered at the Boeing site adjacent to T-117, were found in the test pits near the southern boundary of the site.

2.6.1 Fill Deposits

Fill deposits across the Upland Area include medium dense to dense, poorly-graded sand (SP) and slightly silty sand (SP-SM) with scattered zones of gravelly sand. Very loose, poorly graded sand (SP) fill was encountered in borings drilled in the vicinity of the abandoned meander (Borings GT-1, SC-2, and SC-3). Fill materials are heterogeneous and include dredge spoils, organic material, and manmade materials such as bricks, concrete debris, tar and asphalt. Obstructions, including piles and concrete debris are expected within the site fill. Concrete debris (rip rap) should be expected within fill deposits along shoreline slope. Borehole fill thickness ranged from approximately 5 to 16 feet across the Upland Area. Fill deposits drilled in the vicinity of the abandoned meander near the South Park Marina ranged up to approximately 15 feet deep.

The channel fill in the vicinity of Section C-C' (Figure 5) consists of very loose, poorly graded sand with lenses of sand with trace gravel. The upland fill deposits in this area included medium dense to loose, sand with lenses of sand with trace gravel. Along the Section C-C' shoreline, sand fill includes concrete debris.

In general, it appears that the upland and channel fill are both predominantly composed of poorly-graded sand and were most likely placed at the same time to enlarge (by encroaching on the LDW), raise, and level the T-117 site. The only apparent difference between the upland and channel fill at this location appears to be soil density (loose to medium dense vs. very loose). Fill from these two locations cannot be differentiated based on soil type.

As discussed above, fill deposits that underlie the T-117 site predominantly consist of brown to black poorly graded sand and may contain manmade objects. Younger Alluvium deposits generally consist of dark gray silty sand with scattered organic material, although dark grey sand has also been identified in this unit.

Along Section A-A' between Sta. 9+50 and 7+75 (see Figure 3), the material that directly underlies the recent organic deposits consists of yellow-brown, dark brown, and black poorly-graded sand with localized hydrocarbon odor and manmade objects (blue elastic) that we classified as fill. This material was encountered in borings GT-1, SC-1, SC-2, and SC-3 in the vicinity of the section. No evidence of Younger Alluvium was identified in these borings. The lack of this unit in this area may be related to historic commercial use of this location, including possible localized dredging.

2.6.2 Recent Organic Deposits

Recent organic deposits consisting of very soft to soft, brown to black organic silt (OL) with abundant wood fibers and roots underlie fill across Upland Area and along within the waterway Sediment Area.

Recent organic deposits also overlie fill deposits in the Marina area on the north end of the Sediment Area. Organic deposits, which range between 0 and 5 feet thick across the Upland Area, occur as a discontinuous layer and isolated pockets. Based on site investigations, there is a continuous layer of recent organic deposits up to 9 feet thick at the base of the waterway shoreline within the Sediment Area.

2.6.3 Younger Alluvium

Younger alluvium, including fluvial deposits of sand, silt, and gravel, underlie the majority of the Upland Area beneath the fill and recent organic deposits. Based on project borings, younger alluvium generally consists of very loose to medium dense silty sand (SM), slightly silty sand (SP-SM), and poorly graded sand (SP). Wood fibers and other organic material, silt layers, and scattered zones of sand with gravel are also present.

Based on project borings, younger alluvium is generally encountered below approximately El. 10 feet across the Upland Area and El. -10 feet in the Sediment Area. The lower contact and thickness of the younger alluvium is irregular; however, both the upper and lower contacts increase in depth to the east (toward the waterway).

A lens of medium dense sandy gravel was encountered in boring GT-68 near the southwest corner of the Upland Area at approximately El. 0 feet that is interpreted to be younger alluvium. The base of this gravel lens extends below El. -22 (limit of boring). This is the only location in the Upland Area where this thick gravel lens was encountered; however, an existing boring on the Basin Oil site to the west also penetrated a gravel lens at approximately the same depth, indicating that these gravel lenses may be connected.

2.6.4 Older Alluvium

Older alluvium includes estuarine deposits consisting of predominantly silt and sand. These older deposits are generally distinguished from the younger alluvium based on the presence of shells and increased concentration of silt and clay. Older alluvium generally consists of medium stiff to stiff, very sandy silt (ML), very loose to dense silty sand (SM), and very dense slightly silty sand (SP-SM). Dense to very dense layers containing gravel were also observed in project borings.

Older alluvium was encountered in project borings below approximately El. -30 feet in areas where the upper contact of the glacial deposits exceeds this depth. The thickness of the older alluvium increases toward the center of the Lower Duwamish Waterway channel.

2.6.5 Glacial Deposits

Glacial deposits encountered in site subsurface investigations include medium stiff to hard, gravelly, sandy clay (CH), silty clay (CH), and medium dense to dense slightly gravelly, very clayey sand (SC). Glacial deposits are overconsolidated and locally contain fissures, and slickensides. Iron oxide staining is locally present near the upper contact of this unit. The depth of the glacial deposits is irregular across the site. Project borings and CPTs completed as part of this field investigation generally terminated in glacial deposits.

2.7 Groundwater Characteristics

Groundwater across the T-117 site is influenced by downward gradient flow from the uplands to the west of the site and tidally-influenced inflow from the Lower Duwamish Waterway. Groundwater elevation maps are included in Appendix A. The groundwater at the southwest corner of the site (at Dallas Avenue) experiences the least variation, and the surface is typically between El. 13.5 and 15 feet, based on readings from MW-01. Along the shoreline, where the tidal influence is greatest, the groundwater surface varies between 3.5 and 12 feet, as measured in MW-07, MW-08R, MW-04R, MW-05R, MW-06, and MW-02. The groundwater surface beneath the project area is expected to be highest during high tide (when the groundwater gradient reverses) and during winter and spring storm events.

Tidal fluctuations in the Puget Sound and at the site will vary from as little as about 8 feet per day to as much as 16 to 17 feet per day between the high tide elevation and the low tide elevation. This tidal fluctuation causes the groundwater surface to rise and fall across the project area on a daily basis. Typically the direction of flow is toward the LDW, but the hydraulic gradient can reverse directions at high tide. During low tides, groundwater from the combined sources flows out of the shoreline slope into the waterway. The zone of tidal influence has been estimated at approximately 400 feet (LDW Remedial Investigation, Windward 2010), which is approximately the width of the Upland Area of this site.

Fill deposits, younger alluvium, and older alluvium form an unconfined aquifer across the T117 site. The underlying, relatively-impermeable glacial deposits form a southeastward-sloping aquitard beneath the aquifer. The unconfined aquifer is hydraulically connected to the Lower Duwamish Waterway and groundwater flow from the west. Recent organic deposits form a discontinuous aquitard between the fill and the alluvium that does not appear to confine groundwater flow through the alluvial deposits. Both the older and younger alluvium deposits contain layers of less permeable silt that limit vertical groundwater flow; however, these layers appear to be discontinuous, thus increasing vertical permeability.

The screened sections of the most of the monitoring wells along the shoreline begin in the fill (MW-07, MW-08R, MW-04R, MW-05R, MW-06) and often extend into the recent organic deposit or younger alluvium. Consequently, the extent of the tidal influence on the younger and older alluvium is unclear. The screen interval for MW-02 begins below the fill in the recent organic deposits and extends into the younger alluvium, and much less fluctuation in groundwater surface (El. 9 to 10.5 feet) was measured in this well. This could indicate that the tidal fluctuation is less in the younger alluvium than in the fill, but it may also be a function of its location on the site and the thickness of recent organic deposits in this location.

Medium dense gravel deposits within the younger alluvium that underlie the southwestern portion of the site are expected to be highly permeable and are expected to be in hydraulic connection with both the waterway and groundwater flow from the west.

Recent studies for the LDW Remedial Investigation (Windward 2010) and by Booth and Hermann (1998) indicate there is a downward flow gradient in the younger alluvium, which is dependent on the rainwater that can infiltrate, i.e. presence of interbedded silt. In the deeper aquifer zone, upward flow gradients have been identified in the South Park neighborhood. Where these upward and downward gradients intersect, the interaction has the potential to cause flows toward the LDW, which can discharge as seeps.

2.7.1 Seeps

A bank survey was performed on August 10, 2011 during a minus tide and several seeps were observed. Flow from three of the seeps was great enough to measure with field equipment. Table 1 provides the locations and estimated flow rates of observed seeps. The major seeps are also shown in Figure 1.

TABLE 1. LOCATIONS AND ESTIMATED FLOW AT OBSERVED GROUNDWATER SEEPS

Location	Northing	Easting	Comments
1	195443.700	1275531.556	Measured average flow rate of 210 mL/sec
2	195480.170	1275532.256	Measured flow rate of 100 mL/sec
3	195554.058	1275484.253	Minor seep noted (too small to measure).
4	195590.528	1275484.953	Measured average flow rate of 360 mL/sec
5	195702.308	1275363.545	Two minor seeps noted (too small to measure). Both seeps may be flowing from same source.
6	195702.783	1275338.843	Three seeps noted (two were too small to measure) Measured flow rate of 70 mL/sec in largest seep.
7	195740.201	1275290.140	Two minor seeps noted (too small to measure).
8	195777.620	1275241.438	Four minor seeps noted (too small to measure).
9	195778.095	1275216.736	Three minor seeps noted (too small to measure)

Locations of groundwater seepage were noted by Windward Environmental LLC during their previous site study. The methods used to measure seepage flows are discussed in the "T-117 Sediment, Soil, and Water Field Sampling, Cruise and Data Report prepared by Windward, dated March 4, 2005. For convenience, the location and flow rates for the reported seeps are provided in the Table 2 below. The location of seepages and measured flow rates reported by Windward generally correlate with those noted during the current study.

TABLE 2 . SEEPAGE MEASUREMENTS FROM PREVIOUS SITE STUDIES

Location	Northing	Easting	Measured Flow Rate
T-117-SW1-1	195457	1275512	31 mL/sec
T-117-SW1-2	195563	1275547	780 mL/sec
T-117-SW1-3	195728	1275344	97 mL/sec

3 Engineering Soil Properties

Subsurface conditions for the T-117 site were characterized based on the subsurface exploration program and previous explorations conducted at the site. Geotechnical laboratory testing was conducted on selected samples retrieved from project borings; these tests included natural water content, grain size distribution, and Atterberg limits. Geoprobe explorations and test pits, which were part of the environmental investigation, were also used to characterize the subsurface conditions. Further information on the Subsurface Exploration Program has been presented in the “Terminal 117 Geotechnical Data Report” by JA, dated September 2011, and is summarized in Section 2.4 of this report. Groundwater conditions at the site are discussed in Section 2.7 of this report.

The engineering properties of the site geologic units discussed in Section 2.6 are presented in Table 3. These soil properties will be used for design purposes.

TABLE 3. ENGINEERING SOIL PROPERTIES

Geologic Unit	USCS	Average Blow Count, $N_{1(60)}$	Unit Weight (pcf)	Friction Angle (degrees)	Undrained Shear Strength, S_u (psf)
Recent Organic Deposits	OL, OH, ML	14	90	22-26	0
Younger Alluvium	SP, SP-SM, SM	23	122	35-37	0
Older Alluvium	SP, SP-SM, SM, ML	12	120	33-34	0
Glacial Deposits	CH, SC	59	110	32	1000

4 Geotechnical Design and Construction Considerations

The main component of the Terminal 117 Cleanup Design-Sediment and Upland Areas project is the excavation and removal of contaminated soils. Therefore, the primary geotechnical design and construction considerations for this project are temporary support of excavations and dewatering. We have provided our recommendations below for the design of a temporary sheet pile wall for the project. It is our understanding that the other temporary excavation supports used on site will be designed by the contractor. Our recommendations were developed based construction and excavation plans provided by CRETE. If the nature of the proposed construction and excavation is changed, JA should be notified so we can confirm or re-evaluate our recommendations.

4.1 Temporary Sheet Pile Wall

Given the depths of the upland excavation near the shoreline, a shoreline barrier is planned that would allow for separation of the upland excavation and sediment dredging as well as dewatering of upland soils. A temporary sheet pile has been proposed to provide that shoreline barrier. The temporary sheet pile wall at the T-117 site will be used to separate the dredging operations from the upland excavation, retain river water and sediments during the upland excavation, and retain upland soils and groundwater during dredging operations. The sheet pile wall will also serve as a cut-off wall to allow dewatering of the upland sediments within the walled off area. As shown on Figure 6, the main sheet pile wall is located at about El. 2 feet, and has two wing walls, one located at each end of the main wall to support upland excavations and restrict river water inflow. This section presents the methodology and results for the design of a temporary sheet pile wall excavation support and shoreline barrier system.

4.1.1 Design Cases and Assumptions

The following assumptions were made for the sheet pile wall design:

- Since soil will be removed from both sides of the wall, anchoring the wall would not be feasible. Therefore, the wall was designed as a cantilevered sheet pile wall.
- The sheet pile wall will be installed at the location shown on Figure 6.
- The upland excavations within the interior of the sheet pile wall will be dewatered.
- The sheet piles will be installed from the upland site, and the crane will remain at least 40 feet away from the wall during installation.
- The upland removal and backfill will occur either before or after dredging operations; but, not during.
- The excavation limits were based on the latest excavation prisms provided by CRETE. Excavations extending further than the extents shown on the plan were not considered.
- The top two feet of passive resistance was neglected in all design cases.
- A factor of safety of 1.5 was applied to the passive resistance for all the design cases, except for Design Case 2.
- The wave load used in Design Case 2 was provided by Moffat & Nichol. The wave load assumes a barge with two tugs traveling along the Lower Duwamish River at maximum speed limit of 7 knots with waves up to 1.5 feet at a high tide of El. 14 feet.

Five design cases were developed and analyzed based on subsurface and hydrostatic conditions at the site, and excavation limits at the wall location. The first four design cases considered the exterior side of the

wall to be the passive side and the interior of the wall to be the active side. For the main section of the wall, which parallels the shoreline, the interior of the wall is the upland side of the site and the exterior of the wall is the river or sediment side of the site. For the north wing wall, the exterior side is the north side, and for the south wing wall the exterior side is the south side of the site. The fifth design case considered river water and sediments providing passive resistance to the active pressures from upland soils and groundwater. The stationing in the design cases refers to the stationing shown on Figure 6.

- **Design Case 1** – This load case was applied to the main wall at wall STA 2+40 and STA 1+00. Hydrostatic pressure was applied to the exterior (river side) of the wall based on the extreme high tide at El. 14 feet. The interior ground line was determined based on the excavation prism elevations shown on Figure 6. The upland excavation within the sheet pile wall was assumed to be dewatered to about 1 to 2 feet below the ground line. The top of the wall was assumed to be at El. 18 feet.
- **Design Case 2** – This load case is applied at the same locations at Design Case 1. It is based on Load Case 1, but includes a wave load of 740 lb/ft. The hydrodynamic wave load is applied from El. 15 feet to the exterior ground line. In this load case the hydrostatic load is based on a water height of El. 15 feet, based on the wave height at extreme high tide. Because wave loading is a short-term dynamic load, a safety factor of 1.2 was applied to the passive resistance.
- **Design Case 3** – This load case was applied to the north and south wing walls at STA 0+30 and 4+60, respectively. The interior ground line was determined based on excavation prisms shown on Figure 6. The excavation was assumed to be dewatered to about 1 to 2 feet below the ground line. Hydrostatic pressure was applied to the exterior of the wall based on the groundwater surface elevations shown in Appendix A. The top of the wall is assumed to be at the ground surface.
- **Design Case 4** – This load case was applied to the south wing wall at wall STA 4+25. The interior ground line was determined based on excavation prisms shown on Figure 6. The excavation was assumed to be dewatered to about 1 to 2 feet below the ground line. Hydrostatic pressure was applied to the exterior (south side) of the wall based on the extreme high tide at El. 14 feet.
- **Design Case 5** – This load case was applied to the main wall at STA 1+00; . Hydrostatic pressure was applied to the interior of the wall based on the groundwater surface elevations shown in Appendix A. The exterior ground line was determined based on the excavation prism elevations shown on the Figure 6. The top of the wall was assumed to be at El. 18 feet. A surcharge load of 250 psf was applied on the interior side of the wall, 40 feet from the wall location, to consider the possibility of construction equipment on the upland side of the wall during dredging operations.

Based on the results of our analyses, we recommend that AZ38-700N sections (50 ksi steel) be used to construct the sheet pile wall. Required pile tip elevations for the AZ38-700N sections are shown on Figure 6. The required embedment depths shown on Figure 6 have been increased by 20 percent from the minimum embedment depth calculated, which is the standard of practice. The details of this sheet pile are shown on Figure 7. Deflection of up to 2.0 inches should be expected at the pile head.

The results of our analyses are provided in Appendix D.

Based on the subsurface profiles provided in Figures 3 to 5, we believe that the required pile tip elevations are above the glacial deposits, which may be difficult to drive sheet piles through. However,

the contractor should be prepared to encounter hard driving condition near the recommend pile tip elevations. The contractor also must be prepared to remove surface debris and obstructions prior to sheet pile installation. Obstructions may also be encountered within the fill deposits at the project site. Specification Section 02464-“Sheet Piling” outlines the requirements for the steel sheet piles that will be installed at the site.

4.2 Temporary Slopes

Excavations that exceed 4 feet in depth are required to be shored or must be sloped back or benched to meet minimum WISHA (Washington Industrial Safety and Health Act) requirements. Excavation slopes and benches shall conform to WISHA requirements at all times. The Contractor is responsible for the design of the temporary excavation slopes, with the approval of the Engineer.

There are proposed 2 horizontal to 1 vertical (2H:1V) temporary slopes planned along the river bank for the T-117 project. The current slopes in that area are approximately 1.5H:1V. The current temporary slope design of 2H:1V meets the WISHA requirements for temporary slopes provided in Part N of the Safety Standards for Construction Work, WAC Chapter 296-155. WISHA requires excavation slopes or benches to be designed in accordance with any of the following options:

1. Excavation slopes shall be no steeper than one and one-half horizontal to one vertical (1.5H:1V), in accordance with the slope configurations for Type C soil in Appendix B of Part N. JA has determined that the soil at the site is Type C.
2. Excavation slopes shall be determined in accordance with the conditions and requirements provided in Appendices A and B of Part N.
3. Sloping or benching systems shall be designed in accordance with tabulated data, such as tables and charts.
4. Sloping or benching systems not designed using Options 1, 2 or 3 shall be approved by a registered professional engineer.
5. For excavations greater than 20 feet in depth, the shoring or sloping must be designed by a registered professional engineer.

In accordance with Appendices A and B of Part N (Option 2), the Table 4 below summarizes the WISHA slope requirements for the geologic units at the Project location. Sloping and benching configurations can be found in Appendix B of this memo.

TABLE 4. WISHA SLOPE REQUIREMENTS

Geologic Unit	WISHA Soil Type	Maximum Allowable Slope (H:V)¹
Fill Deposits	C	1.5:1
Recent Organic Deposits	C	1.5:1
Younger Alluvium	C	1.5:1
Older Alluvium	C	1.5:1
Glacial Deposits	B	1:1

^[1] For excavations less than 20 feet deep.

Temporary excavation slopes should be protected from exposure to rain and runoff, to preserve slope stability, by covering with plastic sheeting or other approved means to prevent erosion. The contractor should implement measures to prevent surface water runoff from entering excavations. All temporary excavation slopes should be monitored by the Contractor during construction for any evidence of instability. If instability is detected, the contractor should flatten the temporary excavation slopes or install temporary shoring. If groundwater or groundwater seepage is present, flatter excavation slopes should be expected.

4.3 Temporary Shoring Design Recommendations

The design, planning, installation, monitoring, and removal of all temporary excavation support systems shall be accomplished by the Contractor in such a manner as to maintain the required excavation or trench section and to maintain the stability of the soils below and adjacent to the excavation, prevent inflow of groundwater into excavation, and control ground movements and deformations in accordance with the specified requirements.

Specification Section 02217-“Contractor Designed Excavation Support” specifies requirements to provide temporary excavation support and engineering controls in support of the excavation activity. During the course of the excavation, other excavation areas requiring support may be identified by the Contractor. As outlined in the Specifications, the Contractor is responsible for the design of all temporary excavation support systems, with the approval of the Engineer.

4.4 Ground Deformation and Performance Monitoring

Horizontal and vertical ground deformations are expected to occur as a result of excavations and potential dewatering across the Project site. We recommend an Instrumentation and Monitoring Plan be developed as part of the Contractor-designed excavation support systems to monitor ground behavior associated with the excavations. The instrumentation will be used to monitor the performance of the excavation support systems, as well as to allow for protection of adjacent structures and utilities. We recommend that the excavation support systems and Instrumentation and Monitoring Plan be designed by a professional engineer registered in the State of Washington. The designs should be reviewed and approved by the Engineer for compliance with current practice, and must minimize deformations and protect adjacent structures, such as streets and sidewalks, utilities and poles, and buildings. Monitoring data should be reviewed by the Engineer as it is obtained by the Contractor.

We recommend that an Excavation Support System Plan be submitted by the Contractor for each excavation support system. The details of the Excavation Support System Plan are outlined in Specification Section 02217 – Contractor-Designed Excavation Support.

4.4.1 Performance Requirements

We have developed performance limits and action level recommendations for several structures at and near the T117 site. These recommendations were developed based on the anticipated excavation support systems, subsurface conditions at the T117 site, and structure type. Table 5 provides performance monitoring limits and action level recommendations.

TABLE 5. PERFORMANCE MONITORING AND ACTION LEVEL RECOMMENDATIONS

Structure	Action Level	Limit
Ground Surface adjacent to the Project Site (Dallas Ave., etc.)	First	0.6 inches
	Maximum	1 inch
Buildings	First	0.3 inches
	Maximum	0.5 inches
Sheet Pile Wall	First	1.2 inch
	Maximum	2 inches

The Action Levels shown on Table 5 are included in Specification Section 02340 – Earthwork Instrumentation and Monitoring – Part 3.04. This specification section outlines the requirements for the Contractor-designed Instrumentation and Monitoring Plan and Corrective Action Plan. Each plan will be subject to the approval of the Engineer.

As stated in Specification Section 02340 - Part 3.04, the first action level will:

- Trigger the Corrective Action Plan provided by the Contractor.
- Require alterations to means and methods to reduce movement.
- Require written notice of corrective actions, and double the monitoring frequency.

The maximum action level will:

- Require immediate operation changes to mode of excavation.
- Authorize work stoppage by the Owner.
- Require coordination with the Engineer to develop and implement corrective measures.

4.4.2 Ground Deformation and Vibration

We recommend that ground deformation at the site be limited to the values shown in Table 5. We have estimated ground deformations that may occur in the vicinity of shored excavations and construction equipment, based on empirical correlations related to the current excavation depths shown on the Excavation Plan, subsurface conditions at the site, source type, and distance to the source. The greatest anticipated settlements occurred on Dallas Ave. adjacent to the excavation to El. 4 feet shown on the Excavation Plan at the south corner of the site. For this location, excavation supports and additional considerations may be required to keep deformations within the limits shown in Table 5. Lowering of the groundwater surface outside of the Project site may also cause ground deformations greater than the limits shown in Table 5.

In order to protect private property and address localized ground deformation concerns, we recommend that all Contractor-designed shoring and dewatering be approved by the Engineer. Further, we

recommend that the design team coordinate with local property owners and utility companies to identify all structures that may be affected by construction activity, and to develop measures to protect or relocate at-risk structures.

4.5 Dewatering Recommendations

Based on the excavation plan in Appendix C, there are two main areas of the site to be dewatered. These are:

1. Area A, a rectangular excavation located upland at the site that will be excavated to Elevation -1. This excavation will be approximately 50 feet by 50 feet and must be dewatered due to inflow of groundwater. For the estimate, we assumed a slide rail system shoring system; however, the contractor could use other shoring methods, such as cutting back the sidewalls or installing sheetpiles.
2. Area C, the upland area enclosed by the sheetpile wall into which groundwater and leakage from between and around the sheets flows. The length of this area is approximately 280 feet.

4.5.1 Evaluation

To evaluate the total water quantities that flow into these two excavations, Jacobs Associates used DC-Dewatering, a dewatering computer program. The variables that are input into the program are the size and depth of the excavation; final dewatering depth; the permeability of the soil layers; and an assumed dewatering system.

Based on results from our geotechnical site investigation and subsequent laboratory testing, the predominant soil group at the site is Younger Alluvium (SM to ML), with a permeability of 10^{-4} to 10^{-5} meters per second (m/s). The permeability data was obtained from published tables, which compare grain size data to permeability coefficients. The field investigation performed by Jacobs Associates identified a gravel unit in the southwest portion of the site. The base of the Area A excavation appears to be at the level of the contact. If the gravel layer is encountered, more water will need to be removed to reach equilibrium, since the permeability of the gravel is probably higher than the sand unit above. This gravel layer is included in the analyses, but if it is not encountered the flows will be less. Area C does not encounter this unit.

4.5.2 Conclusions and Recommendations

For modeling purposes, Jacobs Associates used a well point system consisting of the following:

- Vacuum wells that are 25 feet long and installed on 10 foot centers.
- Total number of wells at Area A is 20 and Area C is 30.
- Each well point pumping 11 gallons per minute (gpm) in Area A and 6 gpm in Area C.
- Young Alluvium soil with a permeability of 10^{-4} m/s.
- Gravel unit with a permeability of 10^{-3} m/s.

Given the above parameters, the modeling shows that the groundwater level can be drawn down below the excavation bottom. Vacuum well systems are typically limited to a vertical maximum lift of 20 feet. Since the base of the Area A excavation is more than 20 feet below the current ground surface, the areas adjacent to but outside of Area A would have to be excavated before Area A would be dewatered to the excavation bottom. We estimate the total flow from dewatering in Area A to be 220 gpm, if the gravel is not encountered then the flow from dewatering is estimated to be 160 gpm. The flow from dewatering in Area C is estimated to be 180 gpm.

5 Closure

This report has been prepared exclusively for the use of CRETE Consulting, Inc. and their sub-consultants and contractors for specific application to the Terminal 117 Project. The observations presented in this report are based on the subsurface explorations and observations completed for this investigation, review of previous geotechnical work in the project area, and conversations regarding the project, and are not intended, nor should they be construed to represent, a warranty, but are forwarded to assist in the planning and design process.

Considerable judgment has been applied in interpreting and presenting the results. Subsurface conditions can vary substantially with depth, distance, or due to unanticipated geologic conditions, and the integrity of the geotechnical design elements depends on proper site preparation and construction procedures. As the design develops, we recommend that we be retained to review final design plans and specifications so we can revise or augment our recommendations as required.

The services rendered by Jacobs Associates have been performed in a manner consistent with the level of care and skill ordinarily exercised by members of the profession currently practicing under similar conditions in the same area. If differing conditions are exposed during construction or the design is modified, we should be retained to reevaluate the subsurface conditions and provide written confirmation or modifications, as necessary to this report. Jacobs Associates is not responsible for the use of this report in connection with anything other than the project at the location described above.

6 References

Booth, D.B. and Herman, L. (1998) *Conceptual Model Report, Duwamish Industrial Area Hydrogeologic Pathways Project*: City of Seattle, Office of Economic Development.

Troost, K.G., Booth, D.B., Wisher, A.P., and Shimel, S.A. (2004). *The geologic map of Seattle - A progress report, 2005*, U. S. Geological Survey Openfile report 2005-1252, scale 1:24,000.

Jacobs Associates (2011). *T117 Geotechnical Data Report*, September 2011.

Windward Environmental LLC (2005). *Lower Duwamish Waterway Superfund Site Terminal 117 Early Action Area, T-117 Sediment, Soil, and Water Field Sampling, Cruise and Data Report*, March 4, 2005.

\\jacobs2k.com\jia\jobs\4384.0 - 117 superfund cleanup, port of seattle, wa\CADD\DOCUMENT\FIGURES\FIGURE 1 SITE AND EXPLORATION PLAN.dwg, 8/16/2012 10:16:13 AM, jacobchuk, DWG To PDF, pc3

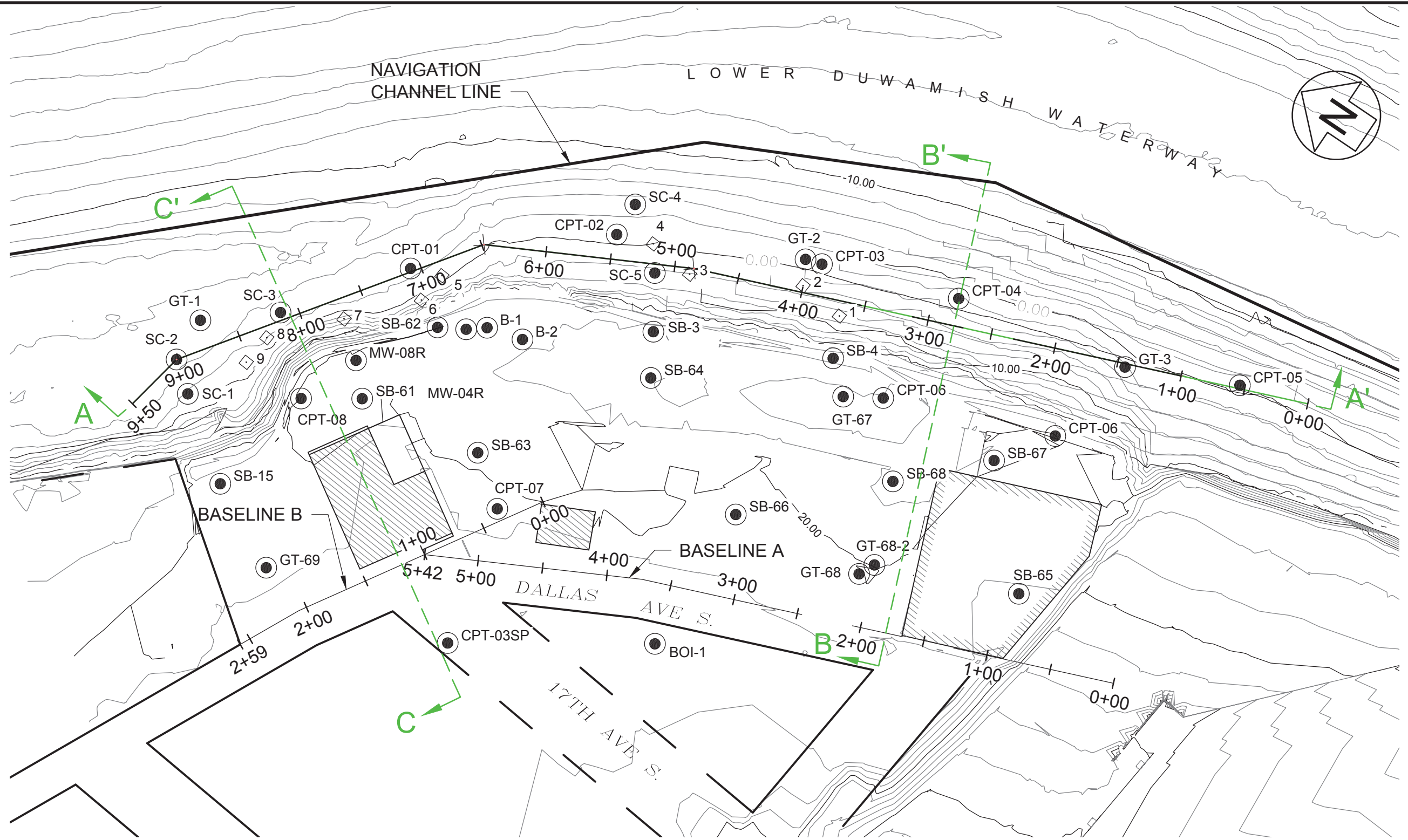

NOTES:

- 1. SEE FIGURE 2 FOR LEGEND.

SITE AND EXPLORATION PLAN

SCALE: 1"=80'



JA PROJECT # 4384.0



TERMINAL 117 CLEANUP DESIGN, SEDIMENT AND UPLAND AREAS
PORT OF SEATTLE, SEATTLE, WA

AUGUST 2012

SITE AND EXPLORATION PLAN

FIGURE 1

\\jacobsk.com\jia\jobs\4384.0 t-117 superfund cleanup, port of seattle, wa\CADD\DOCUMENT\FIGURE 2 PLAN AND PROFILE LEGEND.dwg, 8/16/2012 10:16:20 AM, jacobchuk, DWG To PDF.pc3

UNIFIED SOIL CLASSIFICATION SYSTEM (Based on ASTM D2488 & D2487)				
MAJOR DIVISIONS		GROUP/GRAPHIC SYMBOL	TYPICAL DESCRIPTION	
COARSE-GRAINED SOILS (50% or more retained on No. 200 sieve)	GRAVELS (more than 50% retained on No. 4 sieve)	CLEAN GRAVELS (less than 5% fines)	GW	WELL-GRADED GRAVEL
		GP	POORLY GRADED GRAVEL	
		GRAVELS (with 5 to 12% fines)	GW-GM	WELL-GRADED GRAVEL WITH SILT
			GW-GC	WELL-GRADED GRAVEL WITH CLAY
			GP-GM	POORLY GRADED GRAVEL WITH SILT
			GP-GC	POORLY GRADED GRAVEL WITH CLAY
	GRAVELS WITH FINES (more than 12% fines)	GM	SILTY GRAVEL	
		GC	CLAYEY GRAVEL	
	SANDS (less than 50% retained on No. 4 sieve)	CLEAN SANDS (less than 5% fines)	SW	WELL-GRADED SAND
			SP	POORLY GRADED SAND
		SANDS (with 5 to 12% fines)	SW-SM	WELL-GRADED SAND WITH SILT
			SW-SC	WELL-GRADED SAND WITH CLAY
			SP-SM	POORLY GRADED SAND WITH SILT
			SP-SC	POORLY GRADED SAND WITH CLAY
SANDS WITH FINES (more than 12% fines)			SM	SILTY SAND
			SC	CLAYEY SAND
FINE-GRAINED SOILS (50% or more passes No. 200 sieve)	SILTS & CLAYS (liquid limit less than 50)	INORGANIC	ML	SILT
		CL	LEAN CLAY	
	ORGANIC	OL	LOW PLASTICITY ORGANIC CLAY	
	SILTS & CLAYS (liquid limit greater than 50)	INORGANIC	MH	ELASTIC SILT
		CH	FAT CLAY	
		ORGANIC	OH	HIGH PLASTICITY ORGANIC CLAY
HIGHLY ORGANIC SOILS	PRIMARILY ORGANIC MATTER	PT	PEAT	

NOTES:

- DUAL SOIL SYMBOLS (EG. SP-SM, ML-CL) ARE USED TO INDICATE SOILS HAVING PROPERTIES OF BOTH GROUPS.
- BORDERLINE SOIL SYMBOLS (EG. SP/SM, CL/CH) ARE USED TO INDICATE SOILS WITH PROPERTIES THAT DO NOT DISTINCTLY PLACE THEM IN A SPECIFIC GROUP, SUCH AS INTERBEDDED SOILS WITH DIFFERENT PROPERTIES.

BORING SYMBOLS:

- GT-1 MUD ROTARY SOIL BORING
- SC-4 SEDIMENT VIBRACORE
- SB-61 GEOPROBE SOIL BORING
- CPT-02 CONE PENETRATION TEST
- MW-04R MONITORING WELL
- 1 OBSERVED GROUNDWATER SEEP



RELATIVE DENSITY or CONSISTENCY			
COARSE-GRAINED SOILS		FINE-GRAINED SOILS	
RELATIVE DENSITY	N, SPT BLOWS/FT	CONSISTENCY	N, SPT BLOWS/FT
Very Loose	0 - 4	Very Soft	< 2
Loose	5 - 10	Soft	2 - 4
Medium Dense	11 - 30	Medium Stiff	5 - 8
Dense	31 - 50	Stiff	9 - 15
Very Dense	> 50	Very Stiff	16 - 30
		Hard	> 30

MINOR DESCRIPTORS		MOISTURE CONTENT	
Trace	< 5%	Dry	Absence of moisture, dusty
Slightly (clayey, silty, sandy, gravelly)	5 - 12%	Moist	Damp but no visible water
Clayey, silty, sandy, gravelly	12 - 30%	Wet	Visible free water, from below the water table
Very (clayey, silty, sandy, gravelly)	> 30%		

ABBREVIATIONS:

- MC MOISTURE CONTENT
- SA SIEVE ANALYSIS or -200 WASH
- AL ATTERBERG LIMITS
- TV TORVANE
- PP POCKET PENETROMETER
- N NUMBER OF HAMMER BLOWS FOR LAST 12 INCHES SAMPLED

OTHER SYMBOLS

- ▨ TOPSOIL
- ▨ CONCRETE
- ▨ ASPHALT

SAMPLER SYMBOLS

- ▨ SPLIT SPOON (SPT)
- ▨ MODIFIED CALIFORNIA

CPT LOG LEGEND:

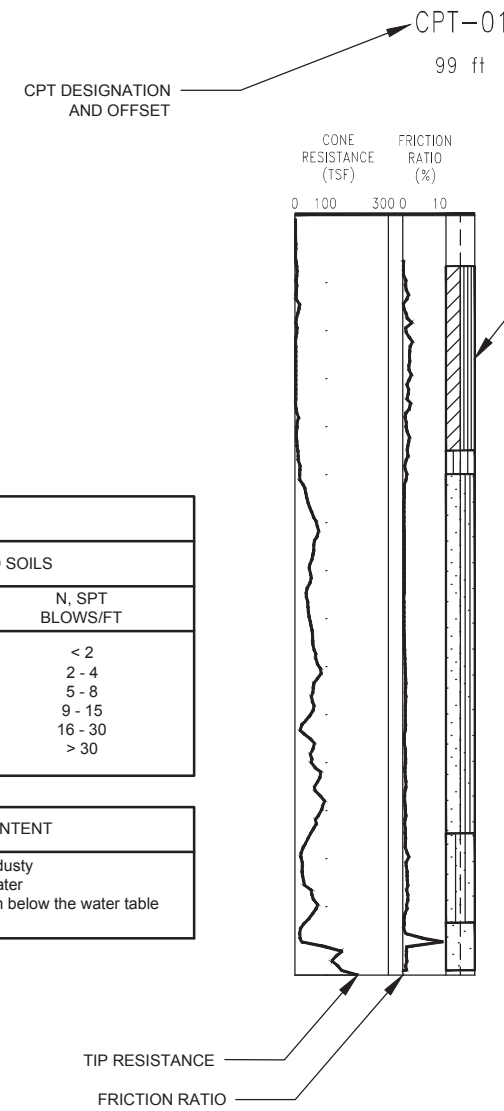

BORING LOG LEGEND:

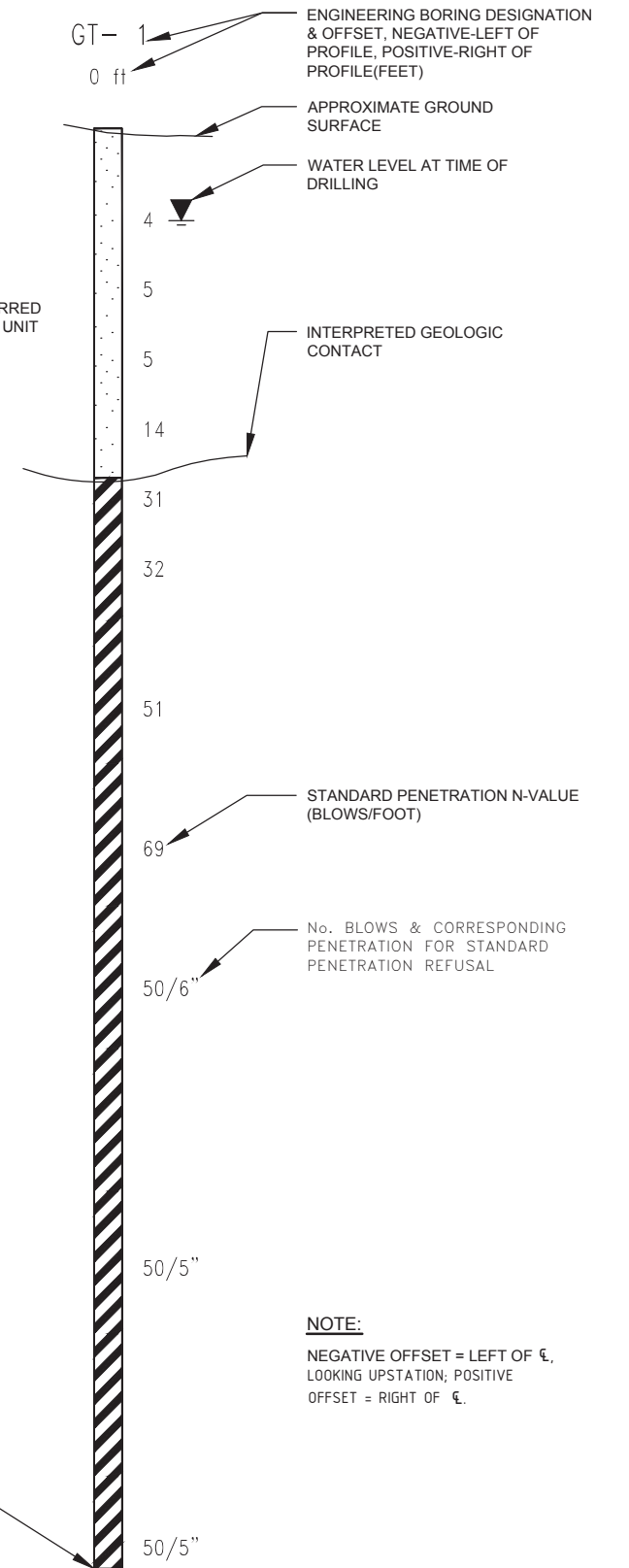

JA PROJECT # 4384.0

TERMINAL 117 CLEANUP DESIGN, SEDIMENT AND UPLAND AREAS
PORT OF SEATTLE, SEATTLE, WA

AUGUST 2012

JACOBS ASSOCIATES

Engineers/Consultants

PLAN AND PROFILE LEGEND

FIGURE 2

\\jacobs2k.com\jia\jobs\4384.0 t-117 superfund cleanup, port of seattle, wa\CADD\DOCUMENT\FIGURES\FIGURE 3 SUBSURFACE PROFILE - PROFILE A.dwg, 8/16/2012 10:16:36 AM, jacobchuk, DWG To PDF.pc3

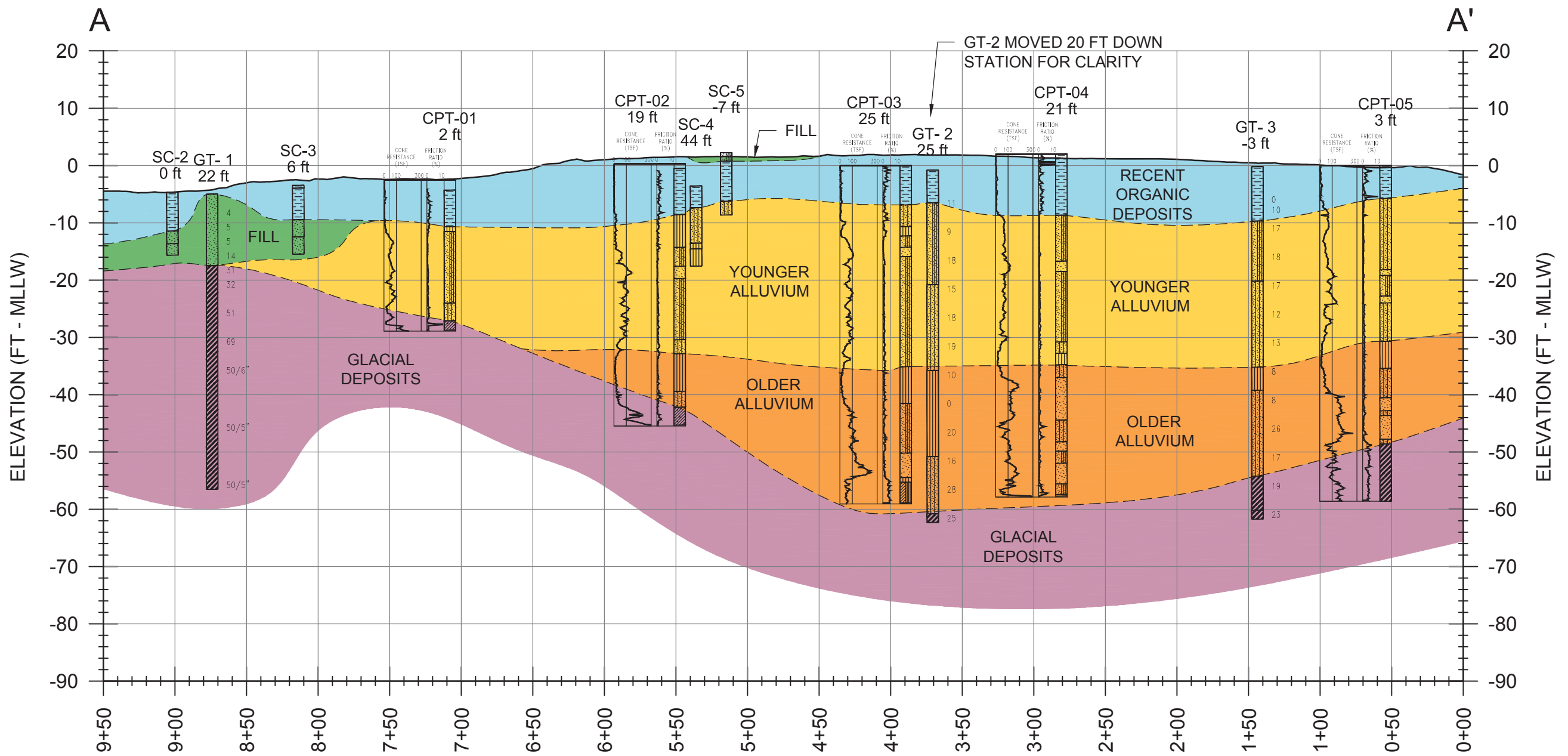

SUBSURFACE PROFILE - PROFILE A

NOTES:

1. SEE REPORT FOR A DESCRIPTION OF GEOLOGIC UNITS.
2. DASHED LINES REPRESENT APPROXIMATE GEOLOGIC CONTACTS.
3. SEE FIGURE 2 FOR LEGEND.

JA PROJECT # 4384.0



TERMINAL 117 CLEANUP DESIGN, SEDIMENT AND UPLAND AREAS
PORT OF SEATTLE, SEATTLE, WA

AUGUST 2012

SUBSURFACE PROFILE - PROFILE A

FIGURE 3

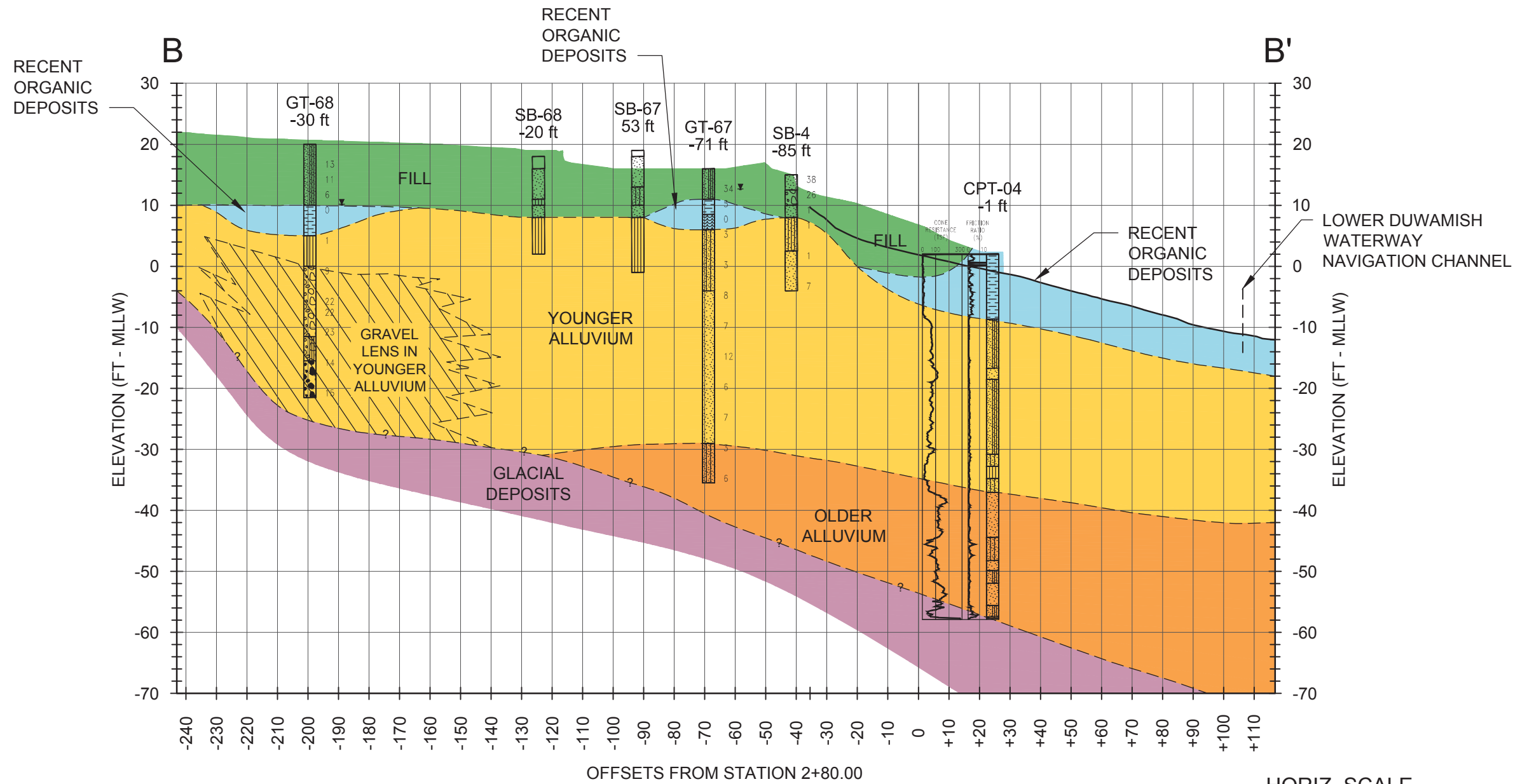

SUBSURFACE PROFILE - SECTION B
 STA 2+80.00

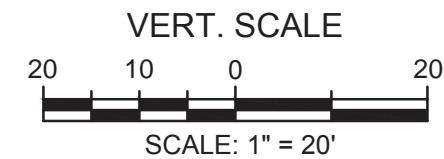
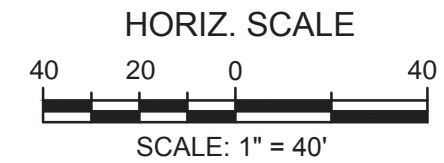

NOTES:

1. SEE REPORT FOR A DESCRIPTION OF GEOLOGIC UNITS.
2. DASHED LINES REPRESENT APPROXIMATE GEOLOGIC CONTACTS.
3. SEE FIGURE 2 FOR LEGEND.

JA PROJECT # 4384.0

JACOBS ASSOCIATES
 Engineers/Consultants

TERMINAL 117 CLEANUP DESIGN, SEDIMENT AND UPLAND AREAS
 PORT OF SEATTLE, SEATTLE, WA

AUGUST 2012

SUBSURFACE PROFILE - SECTION B

FIGURE 4

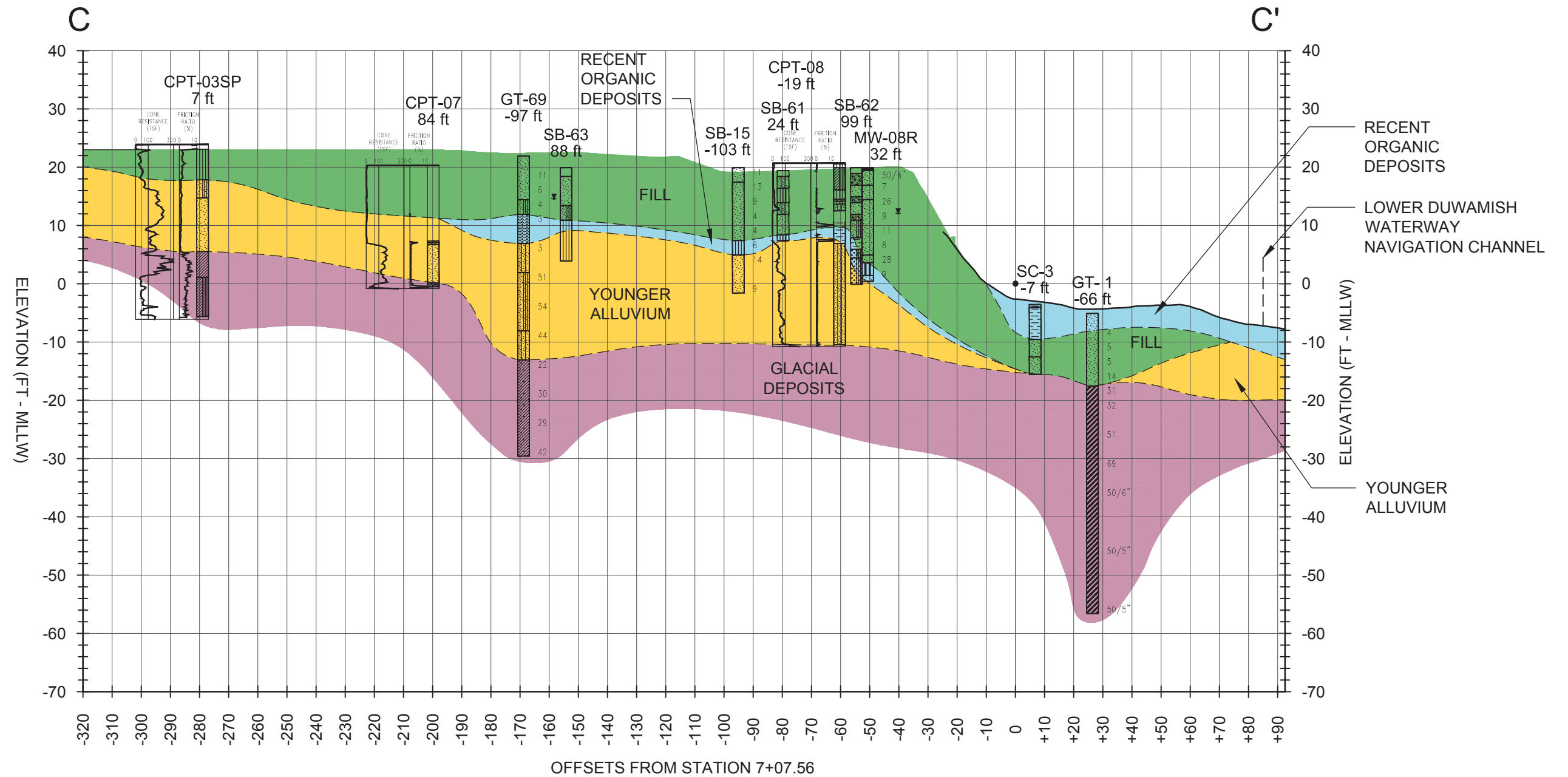

SUBSURFACE PROFILE - SECTION C
STATION 7+07.56

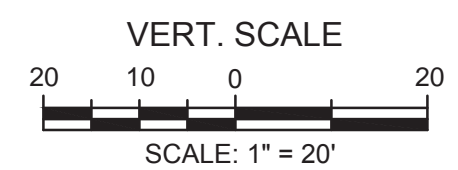
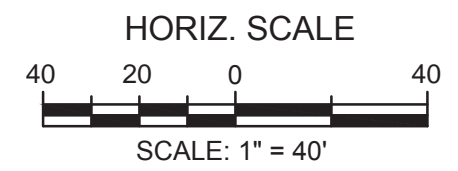

- NOTES:
1. SEE REPORT FOR A DESCRIPTION OF GEOLOGIC UNITS.
 2. DASHED LINES REPRESENT APPROXIMATE GEOLOGIC CONTACTS.
 3. SEE FIGURE 2 FOR LEGEND.

JA PROJECT # 4384.0



TERMINAL 117 CLEANUP DESIGN, SEDIMENT AND UPLAND AREAS
PORT OF SEATTLE, SEATTLE, WA

AUGUST 2012

SUBSURFACE PROFILE - SECTION C

FIGURE 5

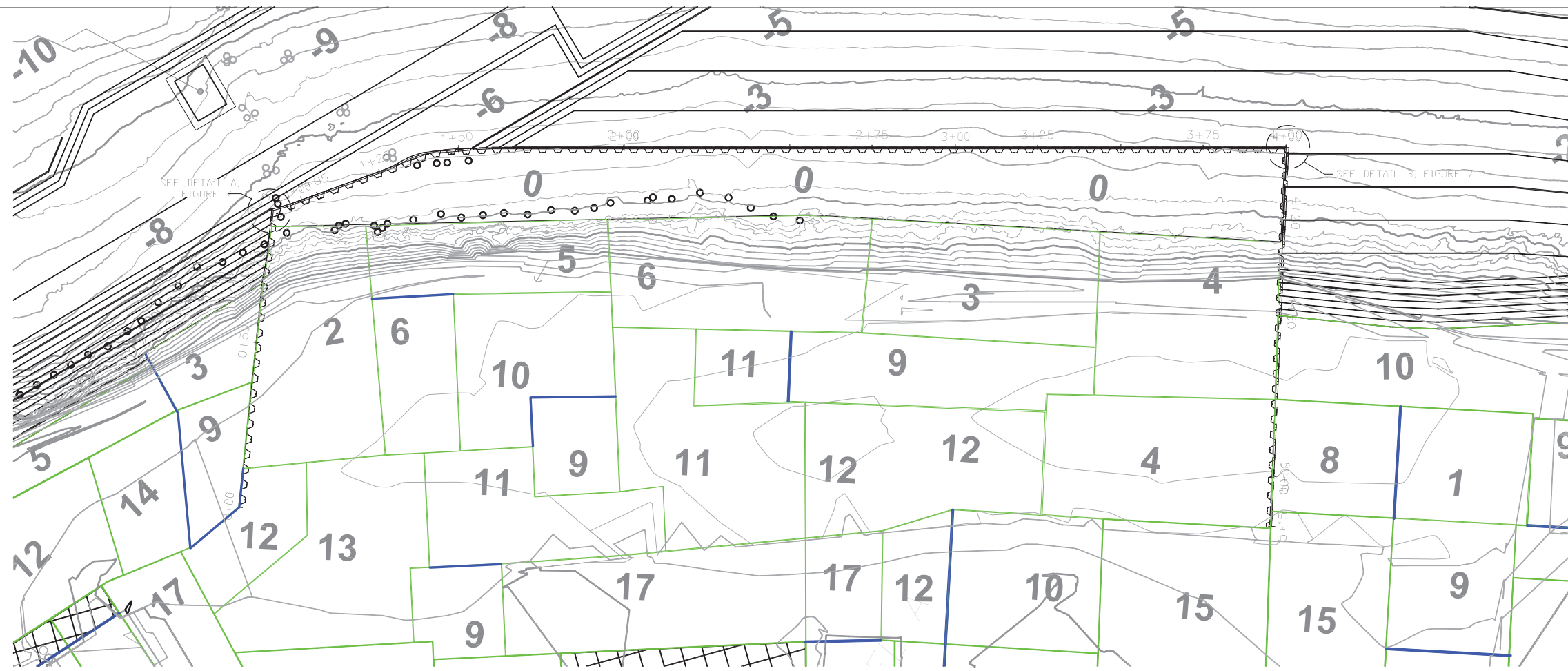

PLAN

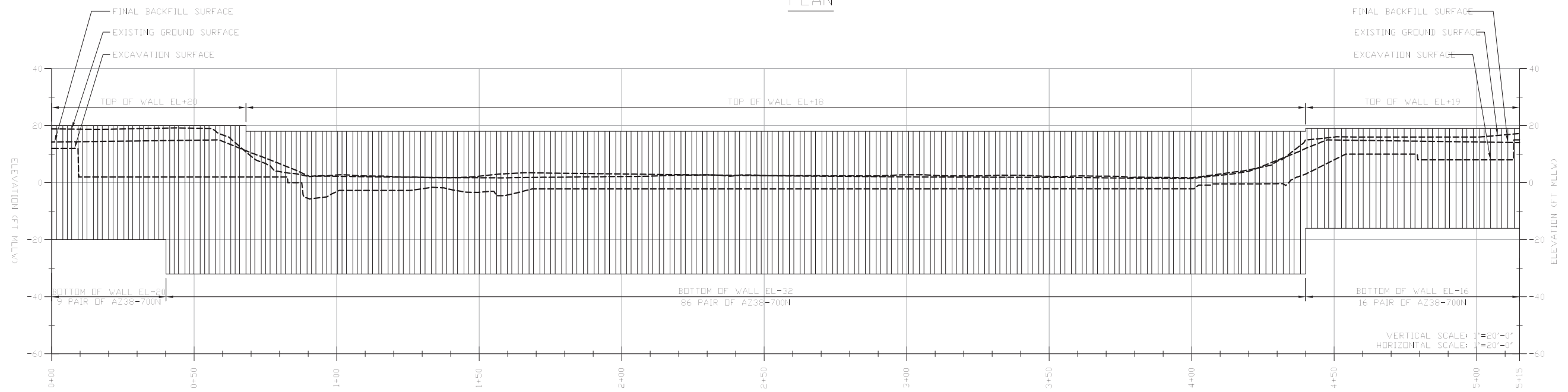

PROFILE - OUTSIDE WALL

JA PROJECT # 4384.0



TERMINAL 117 CLEANUP DESIGN, SEDIMENT AND UPLAND AREAS
 PORT OF SEATTLE, SEATTLE, WA
 60% SHEET PILE WALL DESIGN
 SPW PLAN & PROFILE SHEET

AUGUST 2012

FIGURE 6

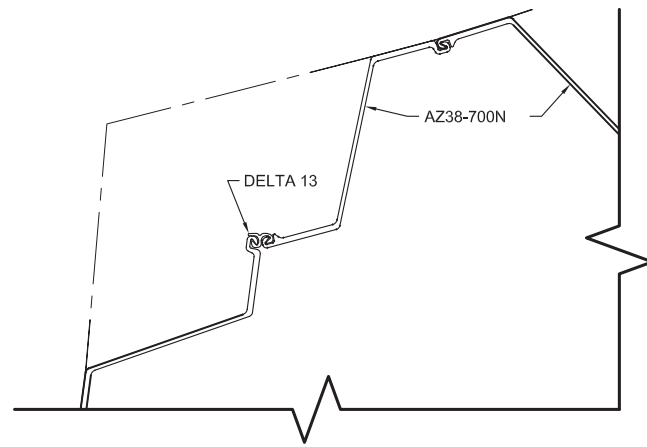

A NORTH CORNER ENLARGED PLAN
NOT TO SCALE

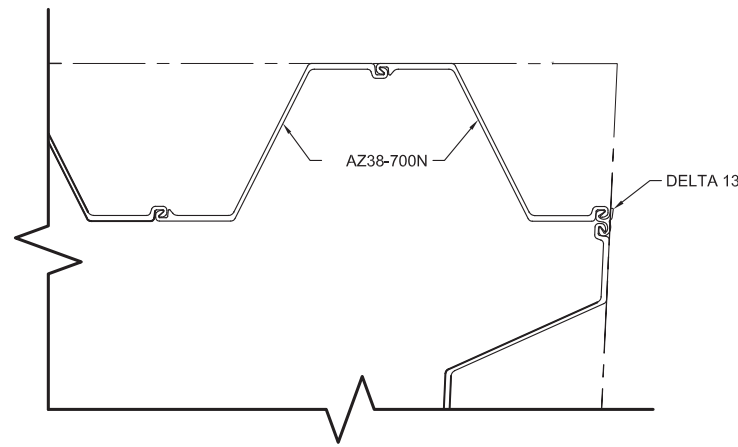

B SOUTH CORNER ENLARGED PLAN
NOT TO SCALE

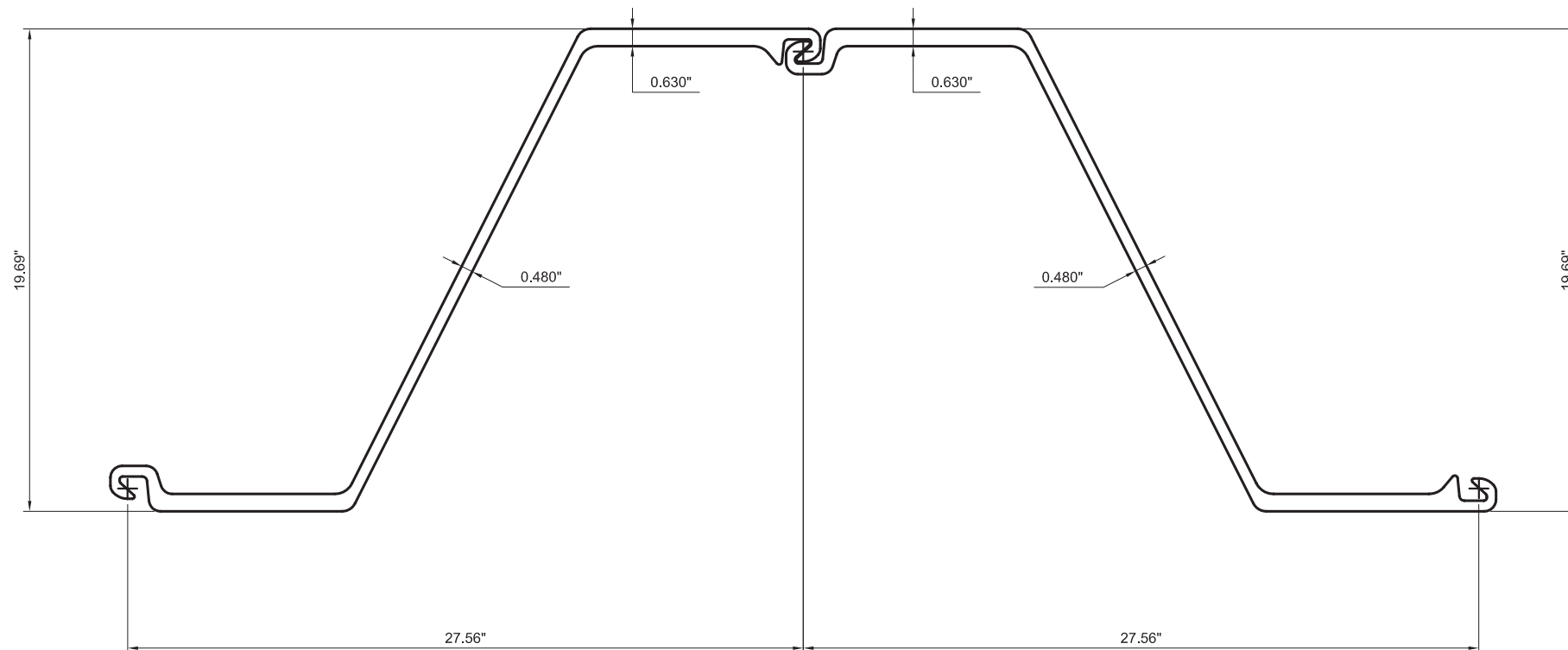

1 AZ38-700N DETAIL
NOT TO SCALE



2 C14 DETAIL
NOT TO SCALE



3 DELTA 13 DETAIL
NOT TO SCALE

NOTES:

1. SHEET PILE WALL SHALL CONSIST OF ARCELOR MITTAL AZ38-700N SECTIONS, SEE DETAIL ON THIS SHEET FOR DIMENSIONAL INFORMATION.
2. SHEET PILE SECTIONS SHALL CONFORM TO ASTM A572 GRADE 50 STEEL.
3. CONTRACTOR MAY INSTALL PREVIOUSLY USED SHEET PILES WITH THE APPROVAL OF THE ENGINEER. USED SHEET PILES MUST COMPLY WITH ALL APPLICABLE REQUIREMENTS.
4. CARE AND CONTROL OF SURFACE WATER, RUN-OFF, AND GROUNDWATER SHALL BE THE SOLE RESPONSIBILITY OF THE CONTRACTOR. THE CONTROL AND DISCHARGE OF WATER SHALL BE MANAGED TO ENABLE THE SAFE COMPLETION AND SATISFACTORY INSTALLATION OF ALL PROJECT COMPONENTS AND TO PREVENT INJURY OR DAMAGE TO INSTALLED FEATURES AND ADJACENT PROPERTIES.
5. THE ENGINEER MAY ADD, ELIMINATE, OR RELOCATE SHEET PILES TO ACCOMMODATE ACTUAL FIELD CONDITIONS. MODIFICATIONS TO THE DESIGN RESULTING FROM ACTIONS OF THE CONTRACTOR SHALL BE REVIEWED BY THE ENGINEER.
6. THE CONTRACTOR SHOULD ANTICIPATE OBSTRUCTIONS DURING SHEET PILE INSTALLATION. IF AN OBSTRUCTION OCCURS WITHIN THE FIRST 10 FEET OF INSTALLATION, THE CONTRACTOR WILL REMOVE THE OBSTRUCTION DURING PERIODS OF LOW TIDES WHEN THE TIDE ELEVATION IS BELOW THE BASE OF WALL ELEVATION AND CONTINUE WITH THE SHEET PILE INSTALLATION. CONTRACTOR SHALL IMMEDIATELY NOTIFY THE ENGINEER IF AN OBSTRUCTION IS ENCOUNTERED DEEPER THAN THE UPPER 10 FEET OF DRIVING.
7. THE CONTRACTOR SHALL IMMEDIATELY SUSPEND SHEET PILE DRIVING OPERATIONS IF GROUND SUBSIDENCE IS OBSERVED, IF THE SHEET PILE WALL IS ADVERSELY AFFECTED, OR IF ADJACENT STRUCTURES ARE DAMAGED AS A RESULT OF THE DRIVING OPERATION. THE ADVERSE CONDITIONS SHALL BE STABILIZED IMMEDIATELY AND THE ENGINEER SHALL BE NOTIFIED OF SUCH CONDITIONS WITHIN 24 HOURS.
8. WELDING SHALL CONFORM TO APPLICABLE PORTIONS OF AMERICAN WELDING SOCIETY (AWS) D1.1-STRUCTURAL WELDING CODE-STEEL; D1.4- STRUCTURAL WELDING CODE-REINFORCING STEEL
9. SEALANT FOR SHEET PILE WALL JOINTS SHALL BE ADEKA ULTRA SEAL A-30 OR AN APPROVED EQUAL. INSTALL SEALANT ACCORDING TO MANUFACTURER'S INSTRUCTIONS.

SHEET PILE WALL CONSTRUCTION STEPS:

1. APPLY SEALANT ACCORDING TO MANUFACTURER'S INSTALLATION INSTRUCTIONS.
2. USE AN ADEQUATE TEMPLATE TO PROPERLY ALIGN THE SHEETS DURING THE SETTING PROCESS AS WELL AS TO KEEP THE SHEETS IN ALIGNMENT DURING THE DRIVING PHASE.
3. MARK THE TEMPLATE TO MAINTAIN THE PUBLISHED LAYING WIDTH OF THE SHEETING SO THAT THE CONTRACTOR CAN OBSERVE IF THE LINE BEING SET IS GAINING OR LOSING WALL LENGTH.
4. SET A PANEL OF PILING. THE SHEETS MAY BE ROTATED AS NECESSARY IN THE INTERLOCK IN ORDER TO MATCH THE MARKS ON THE TEMPLATE.
5. KEEP THE SHEETS PLUMB AND SECURE BEFORE THE NEXT PAIR IS SET.
6. DRIVE THE PANEL OF SHEETS IN STAGES.

JA PROJECT # 4384.0

Appendix A – Groundwater Elevation Maps

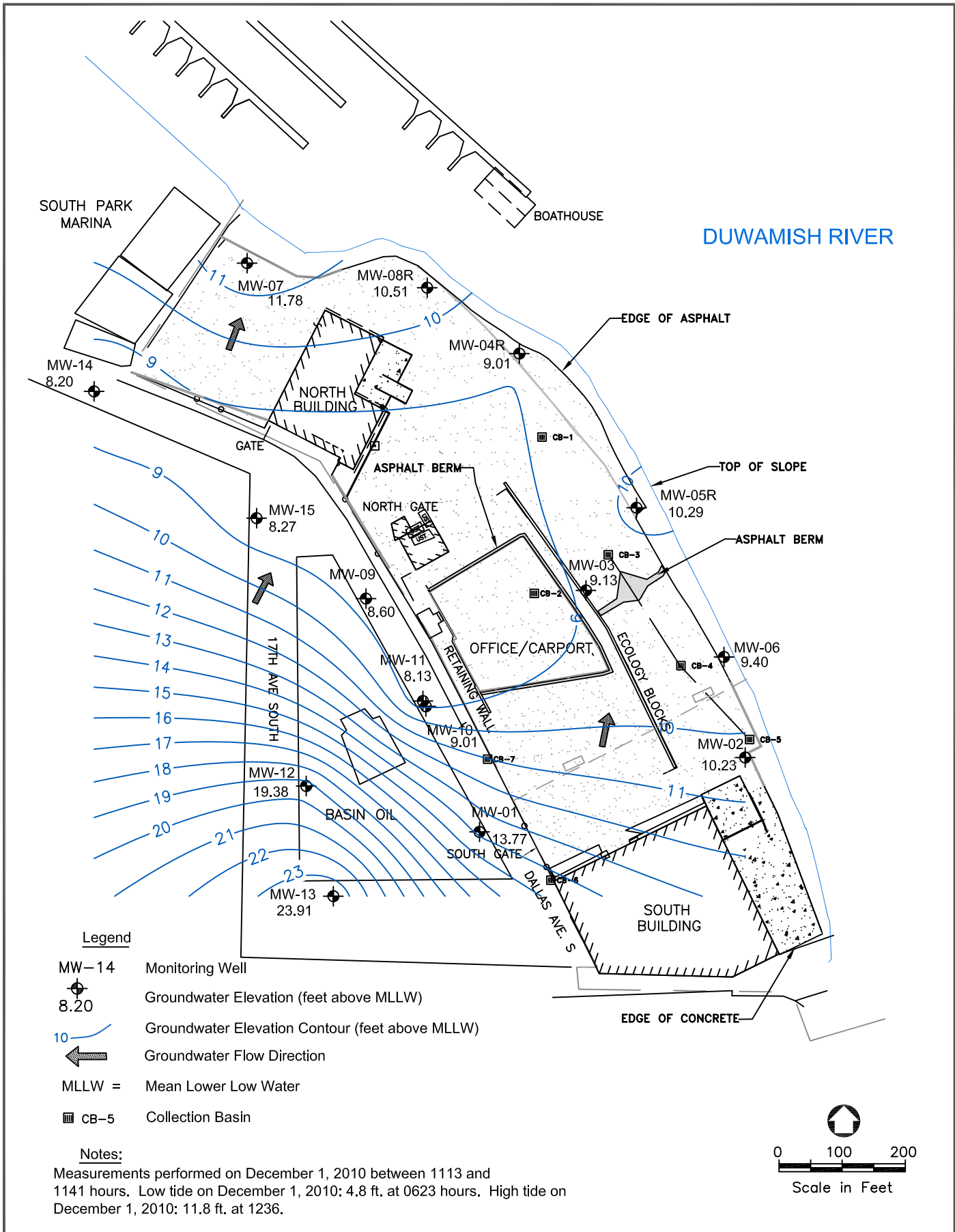

P:\SEALASKA\POSIGW ANNUAL 2011\FIG C-1
 SEPTEMBER 29, 2011

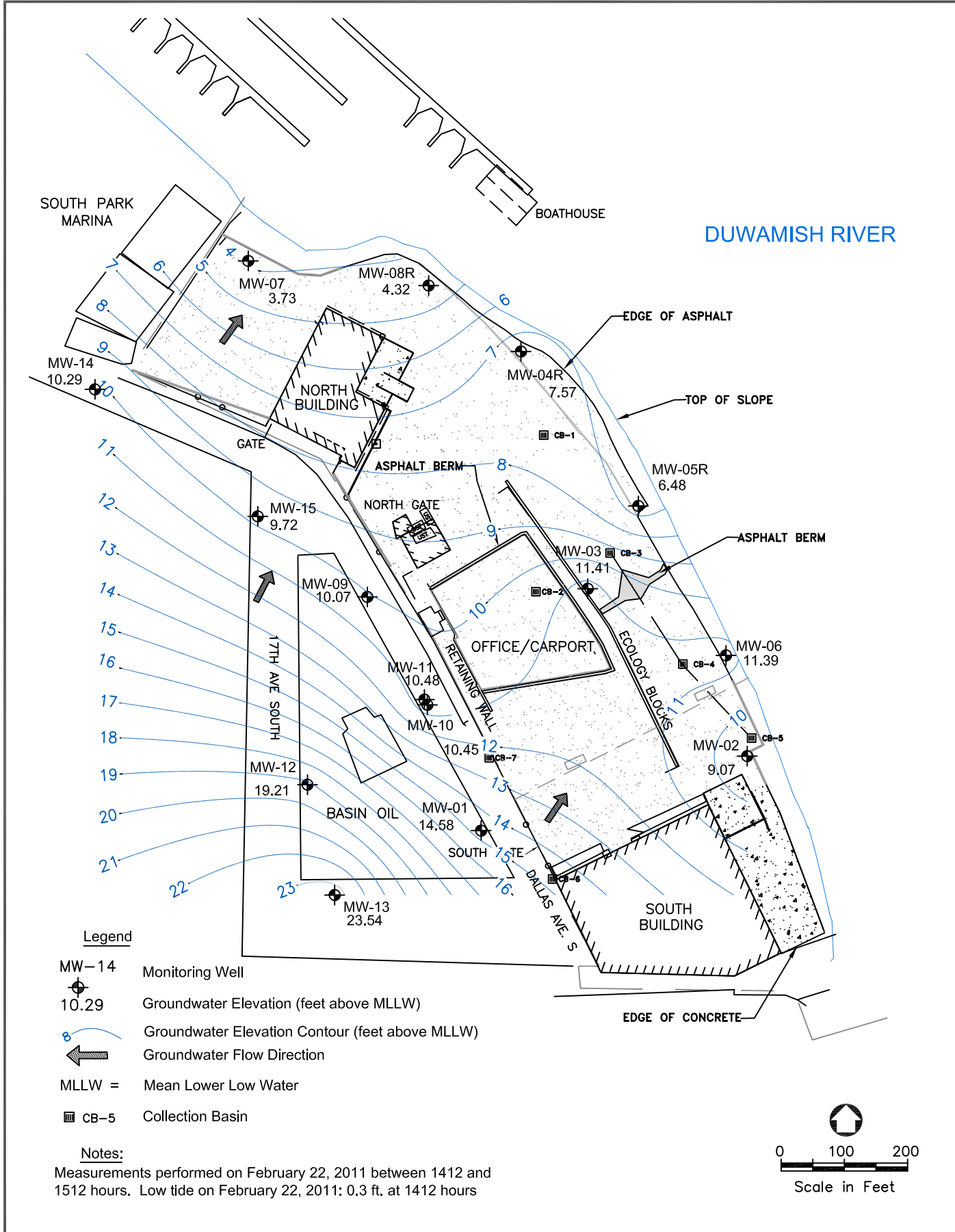

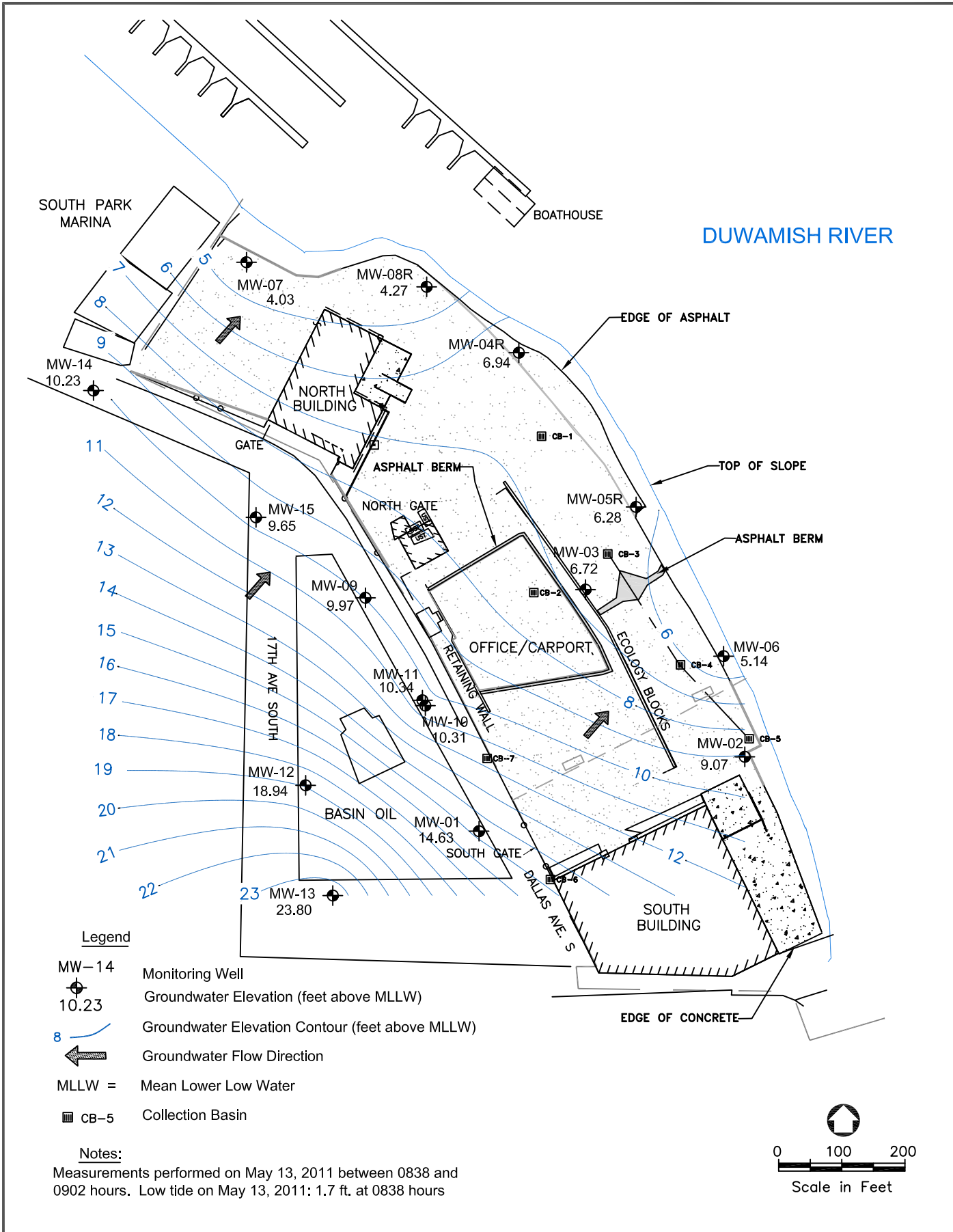

P:\SEALASKA\POSI\GW ANNUAL 2011\FIG C-3
 SEPTEMBER 28, 2011

SEALASKA

Figure C-3
 Groundwater Surface Elevation Map
 Low Tide Second Quarter 2011

Port of Seattle
 Terminal T-117
 Annual GW Report

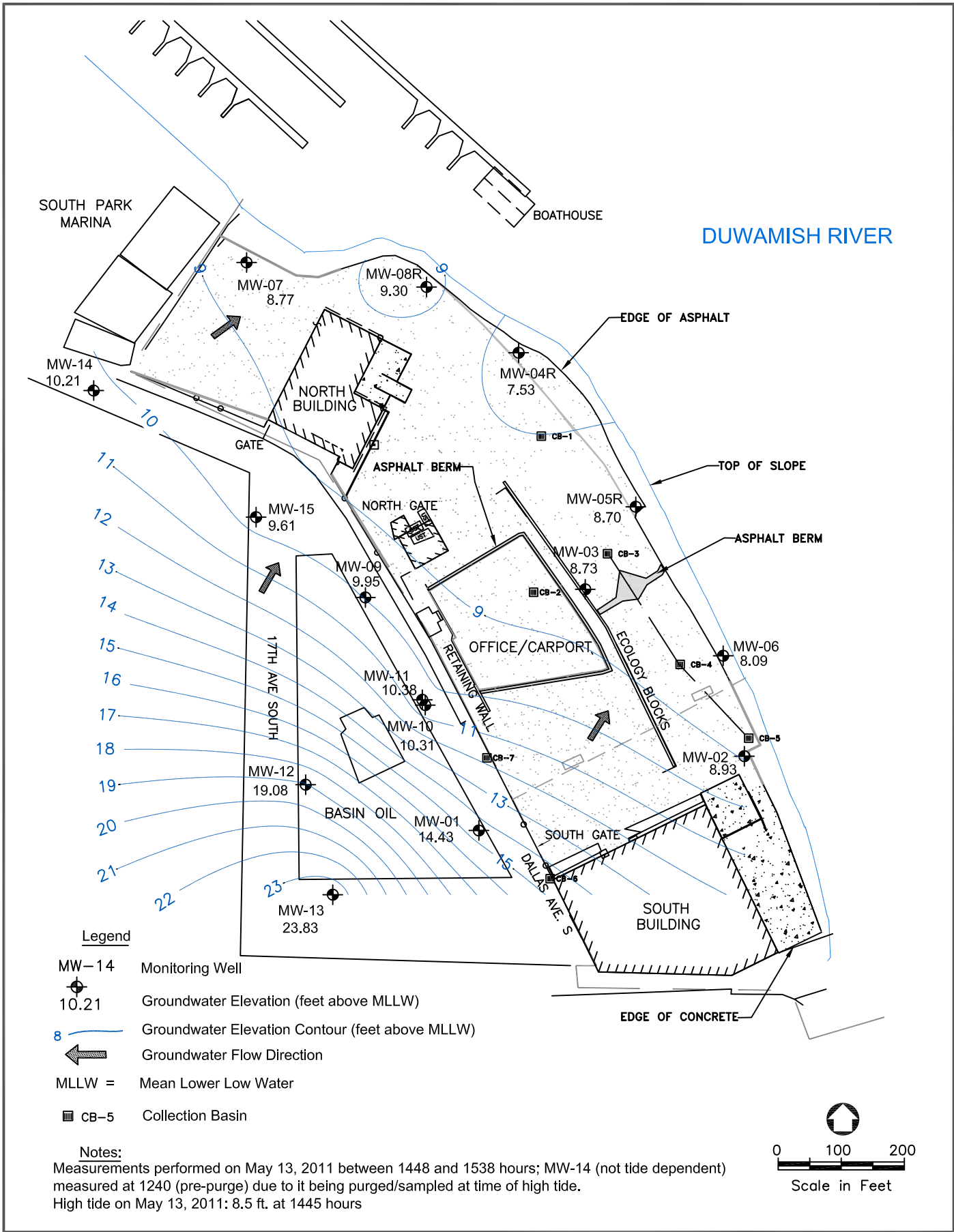

Appendix B – WISHA Requirements for Temporary Slopes

Appendix A

WAC 296-155 – Appendices A and B

WAC 296-155-66401 Appendix A-Soil classification.

(1) Scope and application.

(a) **Scope.** This appendix describes a method of classifying soil and rock deposits based on site and environmental conditions, and on the structure and composition of the earth deposits. The appendix contains definitions, sets forth requirements, and describes acceptable visual and manual tests for use in classifying soils.

(b) **Application.** This appendix applies when a sloping or benching system is designed in accordance with the requirements set forth in [WAC 296-155-657](#) (2)(b) as a method of protection for employees from cave-ins. This appendix also applies when timber shoring for excavations is designed as a method of protection from cave-ins in accordance with appendix C to part N of this chapter, and when aluminum hydraulic shoring is designed in accordance with appendix D. This Appendix also applies if other protective systems are designed and selected for use from data prepared in accordance with the requirements set forth in [WAC 296-155-657](#)(3), and the use of the data is predicated on the use of the soil classification system set forth in this appendix.

(2) **Definitions.** The definitions and examples given below are based on, in whole or in part, the following; American Society for Testing Materials (ASTM) Standards D653-85 and D2488; The Unified Soils Classification System, The U.S. Department of Agriculture (USDA) Textural Classification Scheme; and The National Bureau of Standards Report BSS-121.

(a) **Cemented soil.** A soil in which the particles are held together by a chemical agent, such as calcium carbonate such that a hand-size sample cannot be crushed into powder or individual soil particles by finger pressure.

(b) **Cohesive soil.** Clay (fine grained soil), or soil with a high clay content, which has cohesive strength. Cohesive soil does not crumble, can be excavated with vertical sideslopes, and is plastic when moist. Cohesive soil is hard to break up when dry, and exhibits significant cohesion when submerged. Cohesive soils include clayey silt, sandy clay, silty clay, clay and organic clay.

(c) **Dry soil.** Soil that does not exhibit visible signs of moisture content.

(d) **Fissured.** A soil material that has a tendency to break along definite planes of fracture with little resistance, or a material that exhibits open cracks, such as tension cracks, in an exposed surface.

(e) **Granular soil.** Gravel, sand, or silt, (coarse grained soil) with little or no clay content. Granular soil has no cohesive strength. Some moist granular soils exhibit apparent cohesion. Granular soil cannot be molded when moist and crumbles easily when dry.

(f) **Layered system.** Two or more distinctly different soil or rock types arranged in layers. Micaceous seams or weakened planes in rock or shale are considered layered.

(g) **Moist soil.** A condition in which a soil looks and feels damp. Moist cohesive soil can easily be shaped into a ball and rolled into small diameter threads before crumbling. Moist granular soil that contains some cohesive material will exhibit signs of cohesion between particles.

(h) **Plastic.** A property of a soil which allows the soil to be deformed or molded without cracking, or appreciable volume change.

(i) **Saturated soil.** A soil in which the voids are filled with water. Saturation does not

require flow. Saturation, or near saturation, is necessary for the proper use of instruments such as a pocket penetrometer or shear vane.

(j) **Soil classification system.** For the purpose of this part, a method of categorizing soil and rock deposits in a hierarchy of Stable Rock, Type A, Type B, and Type C, in decreasing order of stability. The categories are determined based on an analysis of the properties and performance characteristics of the deposits and the environmental conditions of exposure.

(k) **Stable rock.** Natural solid mineral matter that can be excavated with vertical sides and remain intact while exposed.

(l) **Submerged soil.** Soil which is underwater or is free seeping.

(m) **Type A.** Cohesive soils with an unconfined compressive strength of 1.5 ton per square foot (tsf) (144 kPa) or greater. Examples of cohesive soils are: Clay, silty clay, sandy clay, clay loam and, in some cases, silty clay loam and sandy clay loam. Cemented soils such as caliche and hardpan are also considered Type A. No soil is Type A if:

(i) The soil is fissured; or

(ii) The soil is subject to vibration from heavy traffic, pile driving, or similar effects; or

(iii) The soil has been previously disturbed; or

(iv) The soil is part of a sloped, layered system where the layers dip into the excavation on a slope of 4 horizontal to 1 vertical (4H.1V) or greater; or

(v) The material is subject to other factors that would require it to be classified as a less stable material.

(n) **Type B.**

(i) Cohesive soil with an unconfined compressive strength greater than 0.5 tsf (48 kPa) but less than 1.5 tsf (144 kPa): or

(ii) Granular cohesionless soils including: Angular gravel (similar to crushed rock), silt, silt loam, sandy loam and, in some cases, silty clay loam and sandy clay loam.

(iii) Previously disturbed soils except those which would otherwise be classed as Type C soil.

(iv) Soil that meets the unconfined compressive strength or cementation requirements for Type A, but is fissured or subject to vibration: or

(v) Dry rock that is not stable: or

(vi) Material that is part of a sloped, layered system where the layers dip into the excavation on a slope less steep than 4 horizontal to 1 vertical (4H.1V), but only if the material would otherwise be classified as Type B.

(o) **Type C.**

(i) Cohesive soil with an unconfined compressive strength of 0.5 tsf (48 kPa) or less: or

(ii) Granular soils including gravel, sand, and loamy sand: or

(iii) Submerged soil or soil from which water is freely seeping: or

(iv) Submerged rock that is not stable, or

(v) Material in a sloped, layered system where the layers dip into the excavation or a slope of 4 horizontal to 1 vertical (4H:1V) or steeper.

(p) **Unconfined compressive strength.** The load per unit area at which a soil will fail in compression. It can be determined by laboratory testing, or estimated in the field using a pocket penetrometer, by thumb penetration tests, and other methods.

(q) **Wet soil.** Soil that contains significantly more moisture than moist soil, but in such a range of values that cohesive material will slump or begin to flow when vibrated. Granular material that would exhibit cohesive properties when moist will lose those cohesive properties when wet.

(3) Requirements.

(a) Classification of soil and rock deposits. Each soil and rock deposit shall be classified by a competent person as Stable Rock, Type A, Type B, or Type C in accordance with the definitions set forth in subsection (2) of this section.

(b) Basis of classification. The classification of the deposits shall be made based on the results of at least one visual and at least one manual analysis. Such analyses shall be conducted by a competent person using tests in subsection (4) of this section or in other recognized methods of soil classification and testing such as those adopted by the American Society for Testing Materials, or the U.S. Department of Agriculture textural classification system.

(c) Visual and manual analyses. The visual and manual analyses, such as those noted as being acceptable in subsection (4) of this section, shall be designed and conducted to provide sufficient quantitative and qualitative information as may be necessary to identify properly the properties, factors, and conditions affecting the classification of the deposits.

(d) Layered systems. In a layered system, the system shall be classified in accordance with its weakest layer. However, each layer may be classified individually where a more stable layer lies under a less stable layer.

(e) Reclassification. If, after classifying a deposit, the properties, factors, or conditions affecting its classification change in any way, the changes shall be evaluated by a competent person. The deposit shall be reclassified as necessary to reflect the changed circumstances.

(4) Acceptable visual and manual tests.

(a) Visual tests. Visual analysis is conducted to determine qualitative information regarding the excavation site in general, the soil adjacent to the excavation, the soil forming the sides of the open excavation, and the soil taken as samples from excavated material.

(i) Observe samples of soil that are excavated and soil in the sides of the excavation. Estimate the range of particle sizes and the relative amounts of the particle sizes. Soil that is primarily composed of fine-grained material is cohesive material. Soil composed primarily of coarse-grained sand or gravel is granular material.

(ii) Observe soil as it is excavated. Soil that remains in clumps when excavated is cohesive. Soil that breaks up easily and does not stay in clumps is granular.

(iii) Observe the side of the opened excavation and the surface area adjacent to the

excavation. Crack-like openings such as tension cracks could indicate fissured material. If chunks of soil spall off a vertical side, the soil could be fissured. Small spalls are evidence of moving ground and are indications of potentially hazardous situations.

(iv) Observe the area adjacent to the excavation and the excavation itself for evidence of existing utility and other underground structures, and to identify previously disturbed soil.

(v) Observe the opened side of the excavation to identify layered systems. Examine layered systems to identify if the layers slope toward the excavation. Estimate the degree of slope of the layers.

(vi) Observe the area adjacent to the excavation and sides of the open excavation for evidence of surface water, water seeping from the sides of the excavation, or the location of the level of the water table.

(vii) Observe the area adjacent to the excavation and the area within the excavation for sources of vibration that may affect the stability of the excavation face.

(b) Manual tests. Manual analysis of soil samples is conducted to determine quantitative as well as qualitative properties of soil and to provide more information in order to classify soil properly.

(i) Plasticity. Mold a moist or wet sample of soil into a ball and attempt to roll it into threads as thin as 1/8-inch in diameter. Cohesive material can be successfully rolled into threads without crumbling. For example, if at least a 2 inch (50 mm) length of 1/8-inch thread can be held on one end without tearing, the soil is cohesive.

(ii) Dry strength. If the soil is dry and crumbles on its own or with moderate pressure into individual grains or fine powder, it is granular (any combination of gravel, sand, or silt). If the soil is dry and falls into clumps which break up into smaller clumps, but the smaller clumps can only be broken up with difficulty, it may be clay in any combination with gravel, sand or silt. If the dry soil breaks into clumps which do not break up into small clumps and which can only be broken with difficulty, and there is no visual indication the soil is fissured, the soil may be considered unfissured.

(iii) Thumb penetration. The thumb penetration test can be used to estimate the unconfined compressive strength of cohesive soils. (This test is based on the thumb penetration test described in American Society for Testing and Materials (ASTM) Standard designation D2488-“Standard Recommended Practice for Description of Soils (Visual-Manual Procedure).”) Type A soils with an unconfined compressive strength of 1.5 tsf can be readily indented by the thumb; however, they can be and penetrated by the thumb only with very great effort. Type C soils with an unconfined compressive strength of 0.5 tsf can be easily penetrated several inches by the thumb, and can be molded by light finger pressure. This test should be conducted on an undisturbed soil sample, such as a large clump of spoil, as soon as practicable after excavation to keep to a minimum the effects of exposure to drying influences. If the excavation is later exposed to wetting influences (rain, flooding), the classification of the soil must be changed accordingly.

(iv) Other strength tests. Estimates of unconfined compressive strength of soils can also be obtained by use of a pocket penetrometer or by using a hand-operated shear vane.

(v) Drying test. The basic purpose of the drying test is to differentiate between cohesive material with fissures, unfissured cohesive material, and granular material. The procedure for the drying test involves drying a sample of soil that is approximately 1 inch thick (2.54 cm) and 6 inches (15.24 cm) in diameter until it is thoroughly dry:

(A) If the sample develops cracks as it dries, significant fissures are indicated.

(B) Samples that dry without cracking are to be broken by hand. If considerable force is necessary to break a sample, the soil has significant cohesive material content. The soil can be classified as a unfissured cohesive material and the unconfined compressive strength should be determined.

(C) If a sample breaks easily by hand, it is either a fissured cohesive material or a granular material. To distinguish between the two, pulverize the dried clumps of the sample by hand or by stepping on them. If the clumps do not pulverize easily, the material is cohesive with fissures. If they pulverize easily into very small fragments, the material is granular.

[Statutory Authority: Chapter 49.17 RCW and RCW 49.17.040, [49.17].050 and [49.17].060. 92-22-067 (Order 92-06), § 296-155-66401, filed 10/30/92, effective 12/8/92.]

WAC 296-155-66403 Appendix B-Sloping and benching.

(1) Scope and application. This appendix contains specifications for sloping and benching when used as methods of protecting employees working in excavations from cave-ins. The requirements of this appendix apply when the design of sloping and benching protective systems is to be performed in accordance with the requirements set forth in [WAC 296-155-657](#) (2)(b).

(2) Definitions.

(a) **Actual slope.** The slope to which an excavation face is excavated.

(b) **Distress.** Soil that is in a condition where a cave-in is imminent or is likely to occur. Distress is evidenced by such phenomena as the development of fissures in the face of or adjacent to an open excavation; the subsidence of the edge of an excavation; the slumping of material from the face or the bulging or heaving of material from the bottom of an excavation; the spalling of material from the face of an excavation; and raveling, i.e., small amounts of material such as pebbles or little clumps of material suddenly separating from the face of an excavation and trickling or rolling down into the excavation.

(c) **Maximum allowable slope.** The steepest incline of an excavation face that is acceptable for the most favorable site conditions as protection against cave-ins, and is expressed as the ratio of horizontal distance to vertical rise (H:V).

(3) Requirements.

(a) **Soil classification.** Soil and rock deposits shall be classified in accordance with appendix A of this Part.

(b) **Maximum allowable slope.** The maximum allowable slope for a soil or rock deposit shall be determined from Table N-1 of this appendix.

(c) **Actual slope.**

(i) The actual slope shall not be steeper than the maximum allowable slope.

(ii) The actual slope shall be less steep than the maximum allowable slope, when there are signs of distress. If that situation occurs, the slope shall be cut back to an actual slope which is at least 1/2 horizontal to one vertical (1/2H:1V) less steep than the maximum allowable slope.

(iii) When surcharge loads from stored material or equipment, operating equipment, or

traffic are present, a competent person shall determine the degree to which the actual slope must be reduced below the maximum allowable slope, and shall assure that such reduction is achieved. Surcharge loads from adjacent structures shall be evaluated in accordance with [WAC 296-155-655\(9\)](#).

(d) Configurations. Configurations of sloping and benching systems shall be in accordance with Figures N-1 through N-18.

SOIL OR ROCK TYPE	MAXIMUM ALLOWABLE SLOPES (H:V) [¹] FOR EXCAVATIONS LESS THAN 20 FEET DEEP [²]
STABLE ROCK	VERTICAL (90°)
TYPE A	3/4:1 (53°)
TYPE B	1:1 (45°)
TYPE C	1 1/2:1 (34°)

NOTES

[¹]: Numbers shown in parentheses next to maximum allowable slopes are angles expressed in degrees from the horizontal. Angles have been rounded off.

[²]: Sloping or benching for excavations greater than 20 feet deep shall be designed by a registered professional engineer.

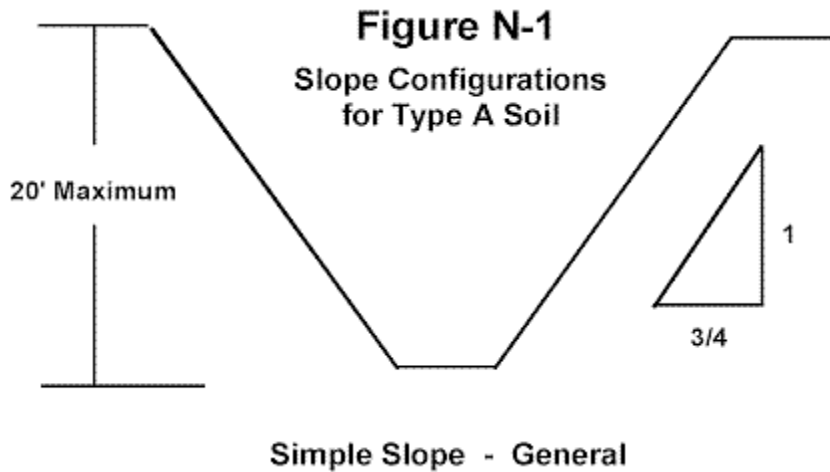

All simple slope excavations 20 feet or less in depth shall have a maximum allowable slope of 3/4:1.

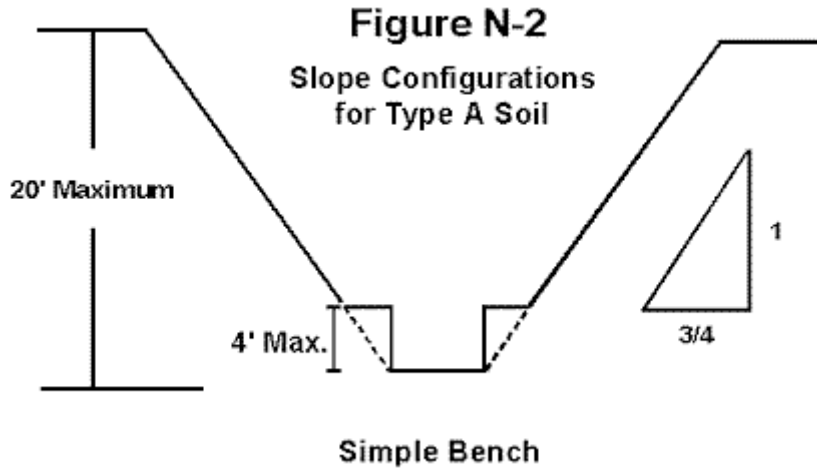

All benched excavations 20 feet or less in depth shall have a maximum allowable slope of 3/4:1 and maximum bench dimensions of 4 feet.

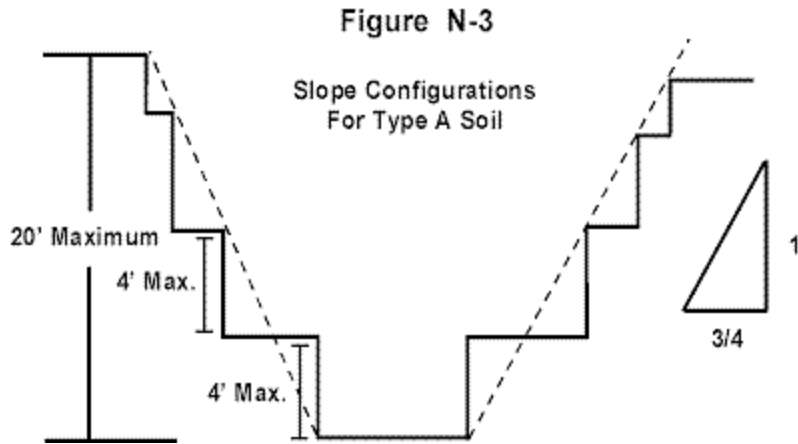

All benched excavations 20 feet or less in depth shall have a maximum allowable slope of 3/4:1 and maximum bench dimensions of 4 feet.

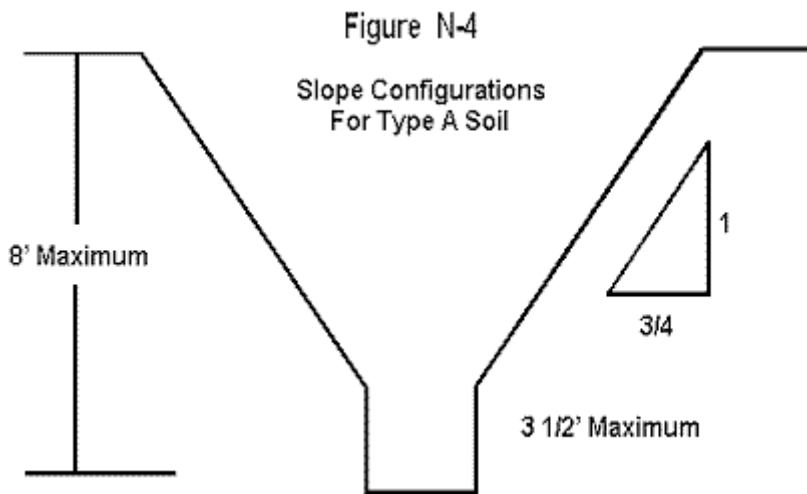

Unsupported Vertically Sided Lower Portion
Maximum 8 Feet in Depth

All excavations 8 feet or less in depth which have unsupported vertically sided lower portions shall have a maximum vertical side of 3 ½ feet.

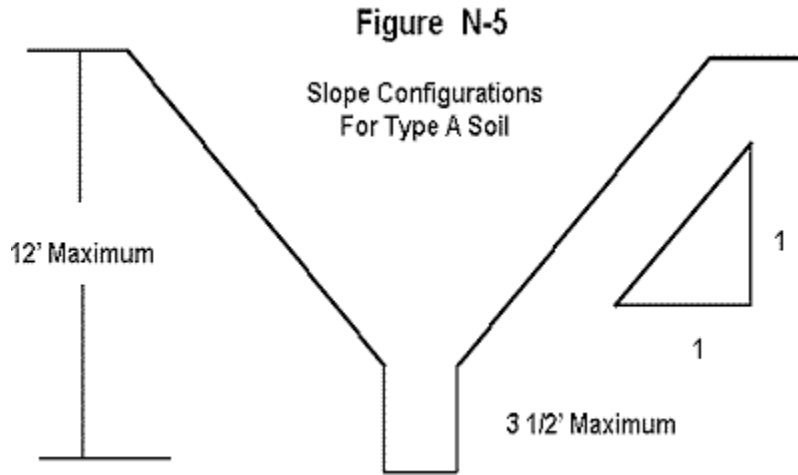

Unsupported Vertically Sided Lower Portion
Maximum 12 Feet in Depth

All excavations more than 8 feet but not more than 12 feet in depth which have unsupported vertically sided lower portions shall have a maximum allowable slope of 1:1 and vertical side of 3 ½ feet.

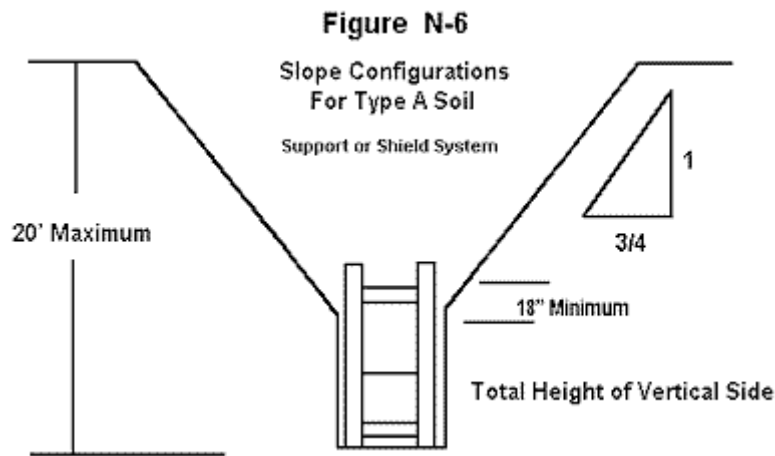

Unsupported Vertically Sided Lower Portion
Maximum 20 Feet in Depth

All excavations 20 feet or less in depth which have vertically sided lower portions that are supported or shielded shall have a maximum allowable slope of 3/4:1. The support or shield system must extend at least 18 inches above the top of the vertical side. All other simple slope, compound slope and vertically sided lower portion excavations shall be in accordance with options permitted under [WAC 296-155-657\(2\)](#).

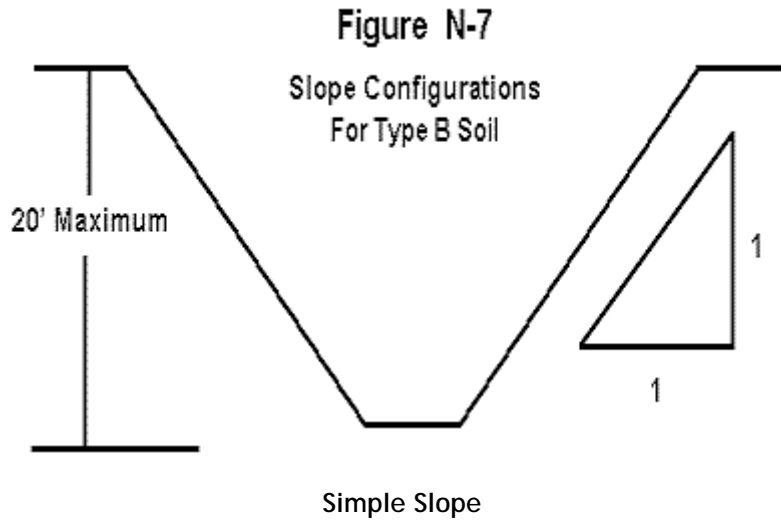

All simple excavations 20 feet or less in depth shall have a maximum allowable slope of 1:1.

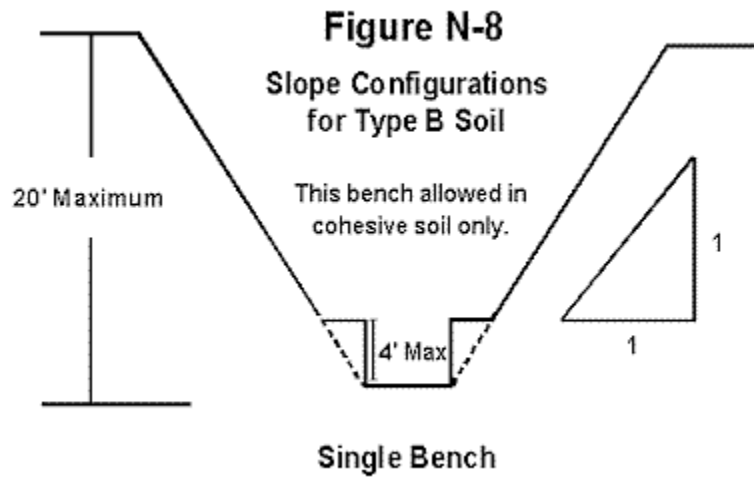

All excavations 20 feet or less in depth shall have a maximum allowable slope of 1:1 and maximum bench dimensions of 4 feet.

Figure N-9

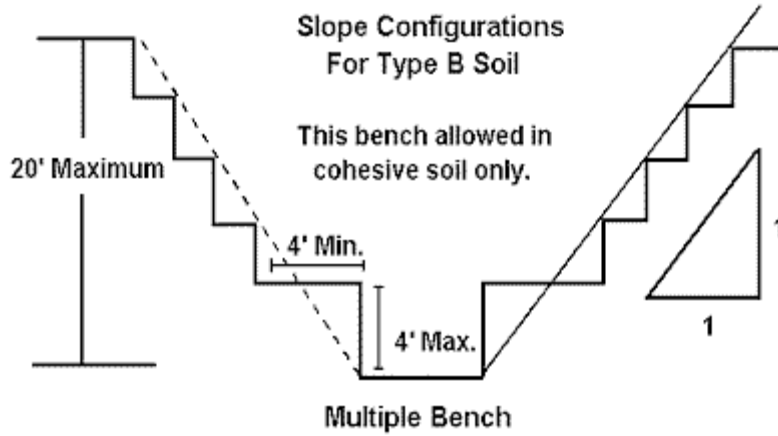

All excavations 20 feet or less in depth shall have a maximum allowable slope of 1:1 and maximum bench dimensions of 4 feet.

Figure N-10

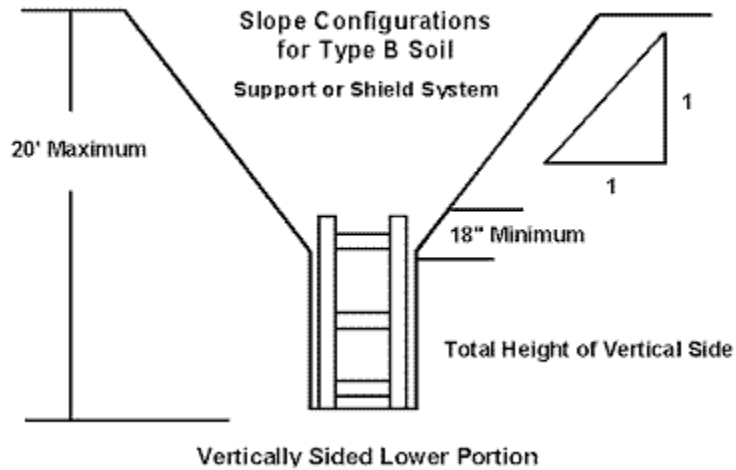

All excavations 20 feet or less in depth which have vertically sided lower portions shall be shielded or supported to a height at least 18 inches above the top of the vertical side. All such excavations shall have a maximum allowable slope of 1:1. All other simple slope, compound slope and vertically sided lower portion excavations shall be in accordance with options permitted under [WAC 296-155-657\(2\)](#).

Figure N-11

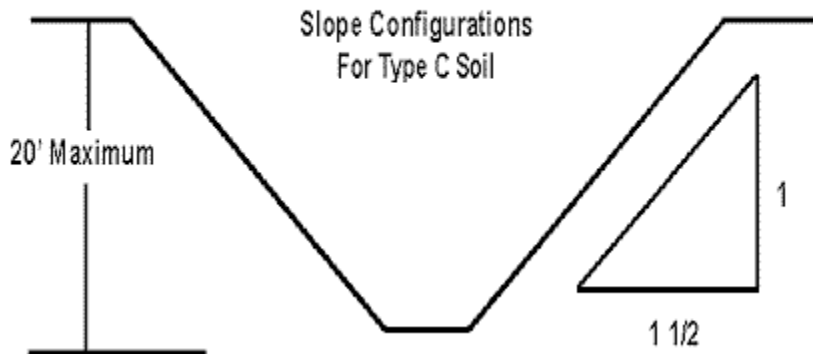

Simple Slope

All simple slope excavations 20 feet or less in depth shall have a maximum allowable

Figure N-12

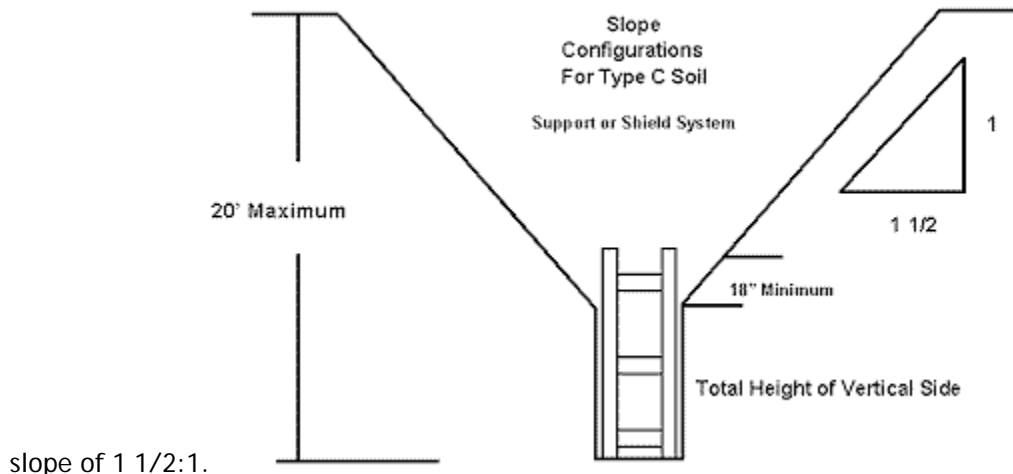

Vertically Sided Lower Portion

All excavations 20 feet or less in depth which have vertically sided lower portions shall be shielded or supported to a height at least 18 inches above the top of the vertical side. All such excavations shall have a maximum allowable slope of 1 1/2:1. All other simple slope, compound slope and vertically sided lower portion excavations shall be in accordance with options permitted under [WAC 296-155-657\(2\)](#).

Figure N-13

EXCAVATIONS MADE IN LAYERED SOILS

All excavations 20 feet or less in depth made in layered soils shall have a maximum allowable slope for each layer as set forth below

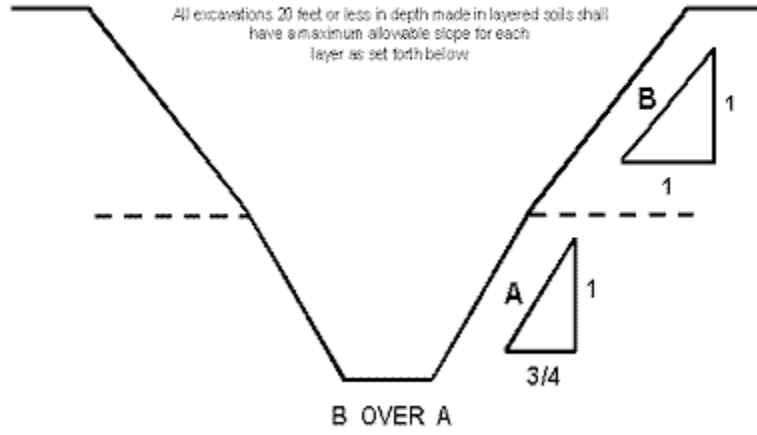
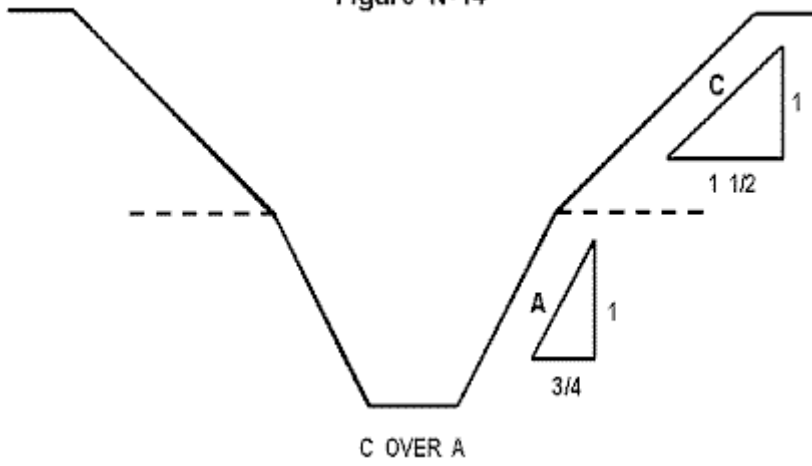

Figure N-14



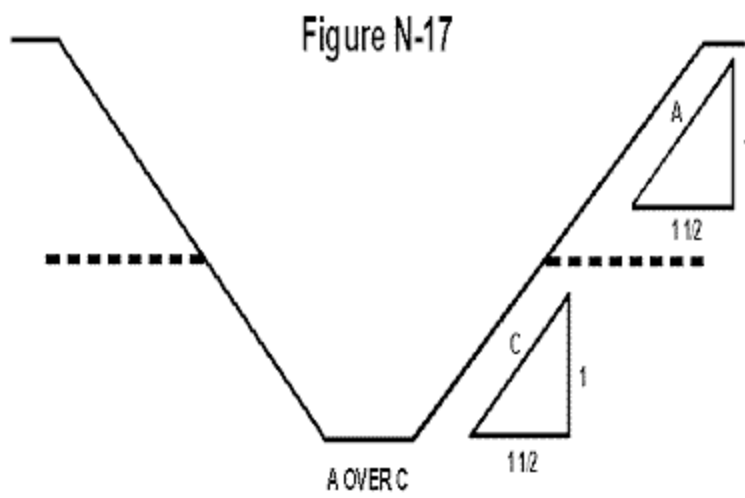
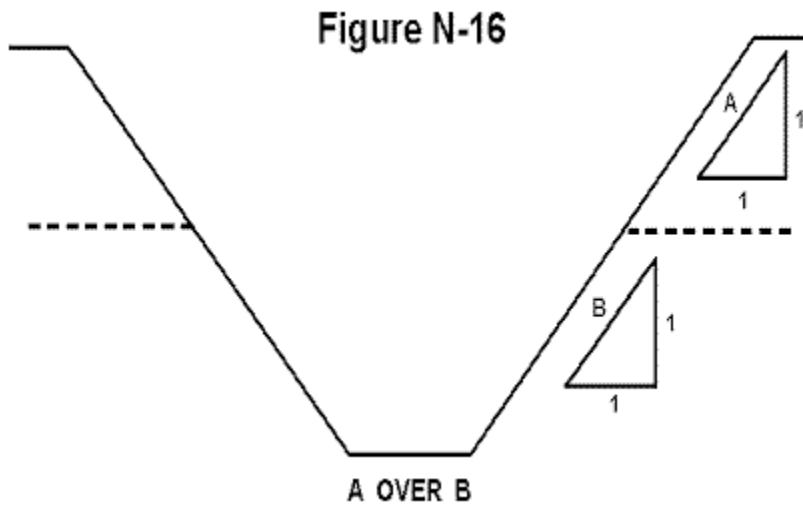
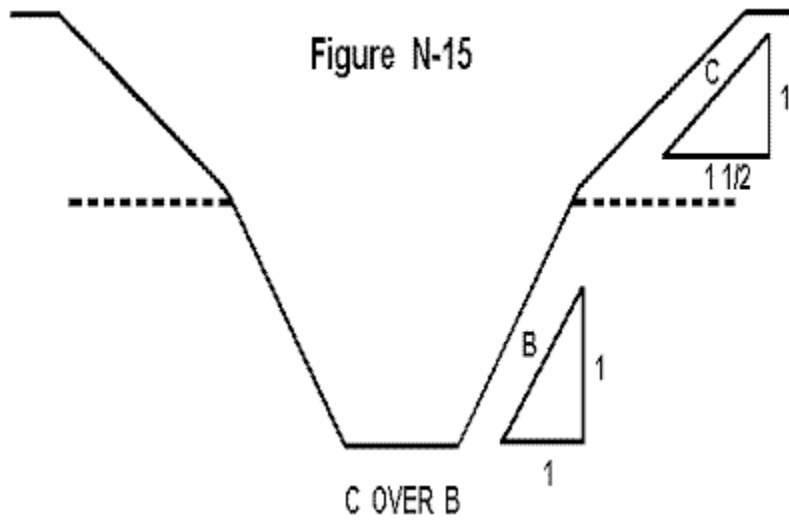
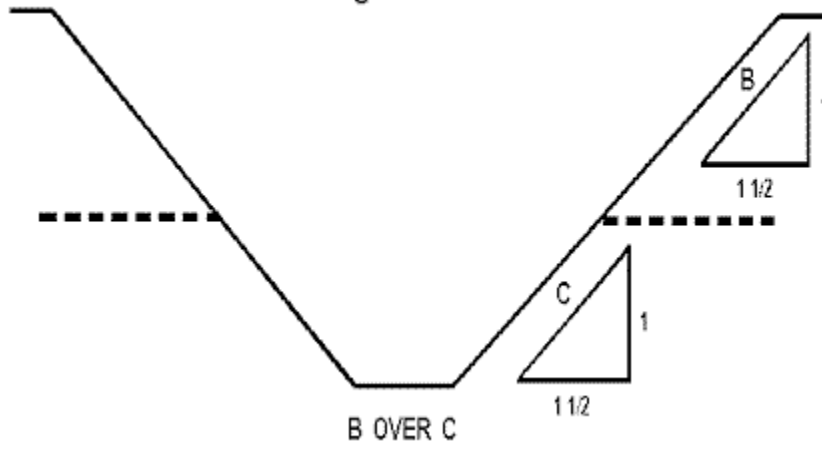

Figure N-18







[Statutory Authority: RCW 49.17.010, .040, .050, 99-17-094 (Order 99-01), § 296-155-66403, filed 08/17/99, effective 12/01/99. Statutory Authority: Chapter 49.17 RCW and RCW 49.17.040, [49.17].050 and [49.17].060, 92-22-067 (Order 92-06), § 296-155-66403, filed 10/30/92, effective 2/8/92.]

[296-155 Part N \(Continued\)](#)

Appendix C – Excavation Plan

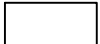
File: K:\Project\clients\Crete\T117\Report - August2012\Crete\T117_2012-08_003.dwg Layout: figure User: swp Plotted: Aug 20, 2012 - 11:50am Xref's:

LEGEND

-  NON-TSCA EXCAVATION CONTOUR
-  NO EXCAVATION AREA
- 9** BOTTOM ELEVATION OF EXCAVATION IN FT MLLW
-  MW-07 MONITORING WELL LOCATION AND ID
-  T-117 STUDY AREA

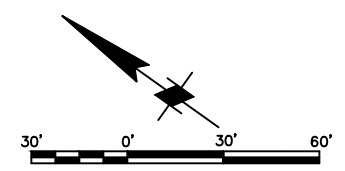
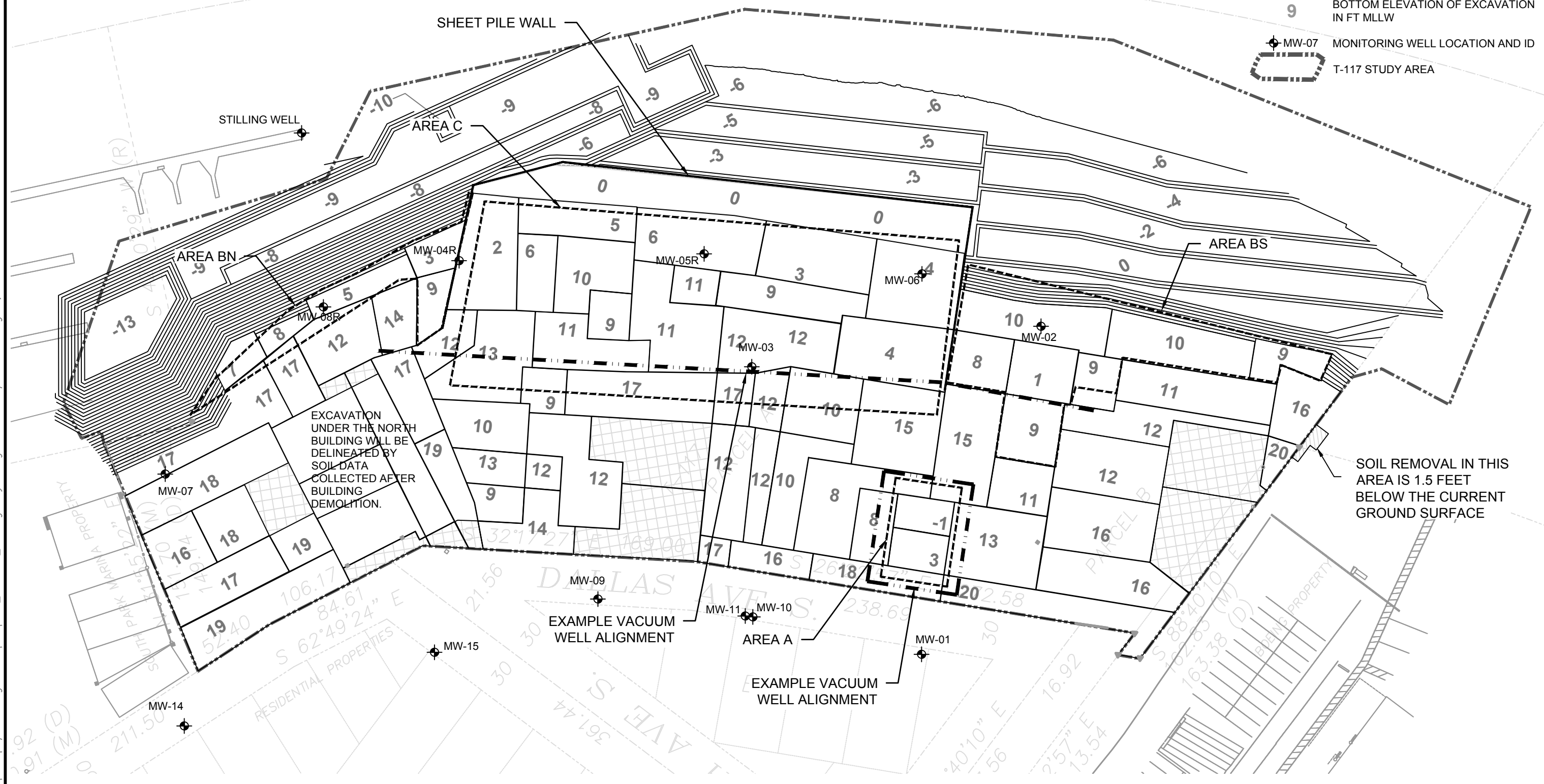

FINAL REMOVAL DESIGN REPORT T-117 EARLY ACTION AREA		ANTICIPATED GROUNDWATER CONTROL AREAS
DATE: 8/17/2012	DRWN: BTS	FIGURE 4-5

Appendix D – Sheetpile Wall Design Calculations

Sheet Pile Wall #1 - STA 3+80

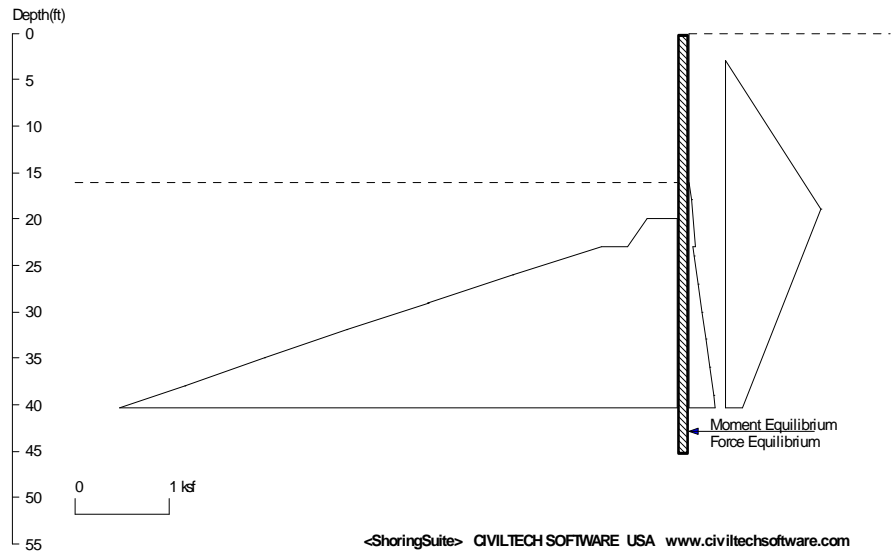

Licensed to 4324324234 3424343 Date: 1/31/2012
 File: I:\4384.0 T-117 Superfund Cleanup, Port of Seattle, WA\60%design\Sheet_Pile_Wall_Design\ShoringSuite\Sheet Pile

Wall Height=16.0 Pile Diameter=1.0 Pile Spacing=1.0 Wall Type: 1. Sheet Pile

PILE LENGTH: Min. Embedment=29.31 Min. Pile Length=45.31 (in graphics and analysis)
 MOMENT IN PILE: Max. Moment=145.68 per Pile Spacing=1.0 at Depth=31.41

PILE SELECTION:

Request Min. Section Modulus = 53.0 in³/ft=2847.98 cm³/m, Fy= 50 ksi = 345 MPa, Fb/Fy=0.66
 AZ38 has Section Modulus = 70.3 in³/ft=3779.33 cm³/m. It is greater than Min. Requirements!
 Top Deflection = 1.39(in) based on E (ksi)=29000.00 and I (in⁴)/foot=637.7

DRIVING PRESSURES (ACTIVE, WATER, & SURCHARGE):

Z1	P1	Z2	P2	Slope
*	Above	Base		
0.000	0.000	16.000	0.000	0.000000
*	Below	Base		
16.000	0.000	18.000	0.020	0.010148
18.000	0.020	23.000	0.071	0.010148
23.000	0.041	24.000	0.055	0.014015
24.000	0.056	27.000	0.097	0.013811
27.000	0.097	30.000	0.138	0.013616
30.000	0.138	33.000	0.179	0.013700
33.000	0.179	36.000	0.220	0.013642
36.000	0.220	39.000	0.261	0.013642
39.000	0.261	42.000	0.302	0.013642
42.000	0.302	45.000	0.343	0.013642
45.000	0.343	48.000	0.384	0.013642
*	Water	Pres.		
3.000	0.000	19.000	1.024	0.064000
19.000	1.024	Tip	0.000	To Tip

PASSIVE PRESSURES:

Z1	P1	Z2	P2	Slope
*	Below	Base		
20.000	0.312	23.000	0.527	0.071720
23.000	0.803	26.000	1.753	0.316426
26.000	1.752	29.000	2.654	0.300708
29.000	2.648	32.000	3.525	0.292413
32.000	3.525	35.000	4.395	0.290041
35.000	4.395	38.000	5.250	0.284964
38.000	5.252	41.000	6.114	0.287343
41.000	6.114	44.000	6.975	0.287034
44.000	6.975	47.000	7.835	0.286866

ACTIVE SPACING:

No.	Z depth	Spacing
1	0.00	1.00
2	16.00	1.00

PASSIVE SPACING:

No.	Z depth	Spacing
1	0.00	1.00

UNITS: Width, Spacing, Diameter, Length, and Depth - ft; Force - kip; Moment - kip-ft
 Friction, Bearing, and Pressure - ksf; Pres. Slope - kip/ft³; Deflection - in

Sheet Pile Wall #1 - STA 3+80

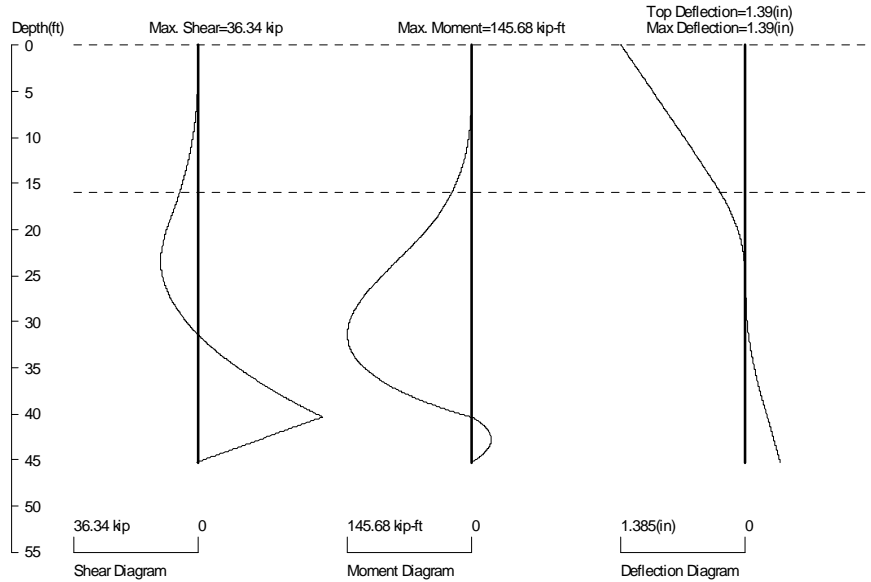
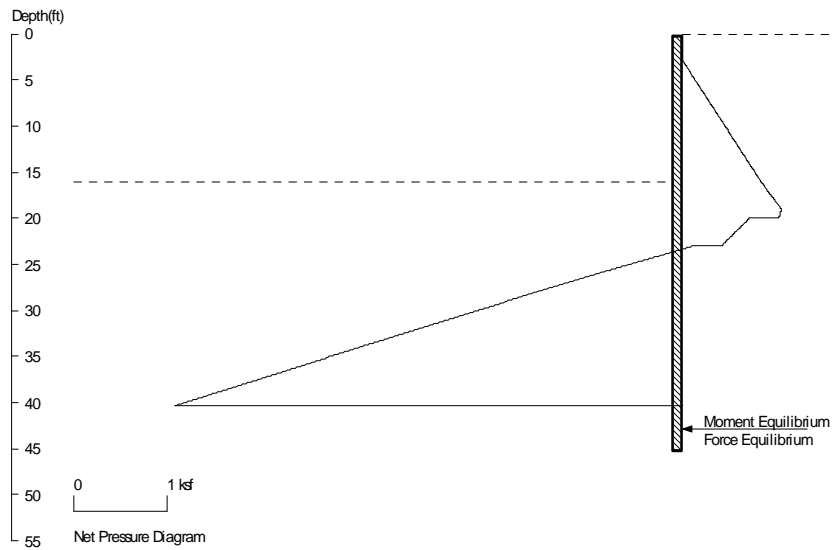

PRESSURE, SHEAR, MOMENT, AND DEFLECTION DIAGRAMS

Based on pile spacing: 1.0 foot or meter

User Input Pile, AZ38: E (ksi)=29000.0, I (in⁴)/foot=637.7

File: I:\4384.0 T-117 Superfund Cleanup, Port of Seattle, WA\60%design\Sheet_Pile_Wall_Design\ShoringSuite\Sheet Pile Wall1(3+80).sh8

<ShoringSuite> CIVILTECH SOFTWARE USA www.civiltechsoftware.com

Licensed to 4324324234 3424343

Sheet Pile Wall #1 - STA 5+17

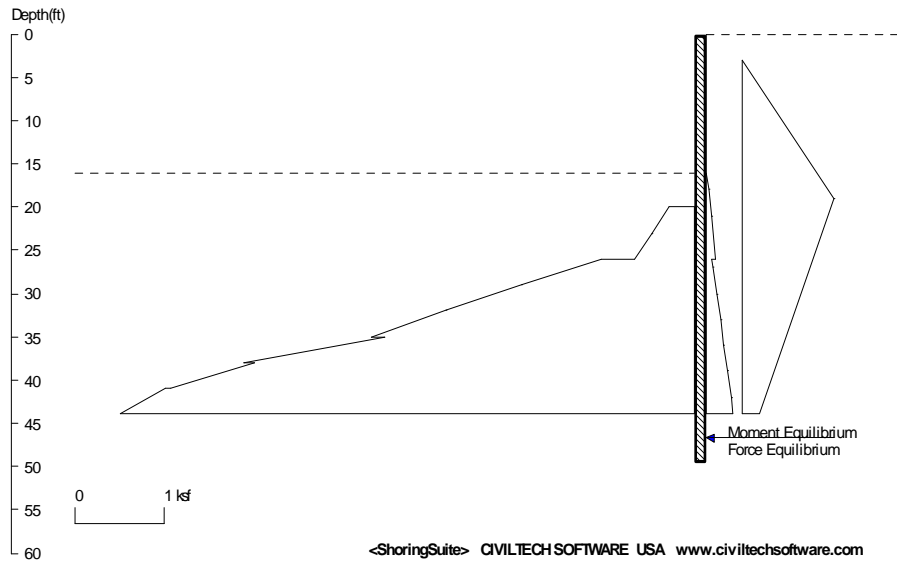

Licensed to 4324324234 3424343 Date: 1/31/2012
 File: I:\4384.0 T-117 Superfund Cleanup, Port of Seattle, WA\60%\design\Sheet_Pile_Wall_Design\ShoringSuite\SheetPileV

Wall Height=16.0 Pile Diameter=1.0 Pile Spacing=1.0 Wall Type: 1. Sheet Pile

PILE LENGTH: Min. Embedment=33.48 Min. Pile Length=49.48 (in graphics and analysis)
 MOMENT IN PILE: Max. Moment=183.51 per Pile Spacing=1.0 at Depth=34.31

PILE SELECTION:

Request Min. Section Modulus = 66.7 in³/ft=3587.42 cm³/m, Fy= 50 ksi = 345 MPa, Fb/Fy=0.66
 AZ38 has Section Modulus = 70.3 in³/ft=3779.33 cm³/m. It is greater than Min. Requirements!
 Top Deflection = 1.80(in) based on E (ksi)=29000.00 and I (in⁴/foot)=637.7

DRIVING PRESSURES (ACTIVE, WATER, & SURCHARGE):

Z1	P1	Z2	P2	Slope
*	Above	Base		
0.000	0.000	16.000	0.000	0.000000
*	Below	Base		
16.000	0.000	18.000	0.020	0.009998
18.000	0.020	21.000	0.050	0.009998
21.000	0.050	26.000	0.100	0.009998
26.000	0.059	27.000	0.072	0.013399
27.000	0.073	30.000	0.114	0.013743
30.000	0.114	33.000	0.154	0.013547
33.000	0.154	36.000	0.195	0.013727
36.000	0.195	39.000	0.236	0.013475
39.000	0.236	42.000	0.276	0.013475
42.000	0.276	46.000	0.330	0.013475
46.000	0.358	48.000	0.386	0.014127
48.000	0.386	51.000	0.429	0.014127
*	Water	Pres.		
3.000	0.000	19.000	1.024	0.064000
19.000	1.024	Tip	0.000	To Tip

PASSIVE PRESSURES:

Z1	P1	Z2	P2	Slope
*	Below	Base		
20.000	0.282	23.000	0.473	0.063631
23.000	0.473	26.000	0.664	0.063631
26.000	1.029	29.000	1.931	0.300662
29.000	1.927	32.000	2.775	0.282615
32.000	2.768	35.000	3.596	0.275933
35.000	3.454	38.000	5.031	0.525830
38.000	4.912	41.000	5.837	0.308428
41.000	5.906	46.000	6.780	0.174761
46.000	5.707	47.000	5.871	0.164019
47.000	5.870	50.000	6.356	0.162042

ACTIVE SPACING:

Nb.	Z depth	Spacing
1	0.00	1.00
2	16.00	1.00

PASSIVE SPACING:

Nb.	Z depth	Spacing
1	0.00	1.00

UNITS: Width, Spacing, Diameter, Length, and Depth - ft; Force - kip; Moment - kip-ft
Friction, Bearing, and Pressure - ksf; Pres. Slope - kip/ft³; Deflection - in

Sheet Pile Wall #1 - STA 5+17

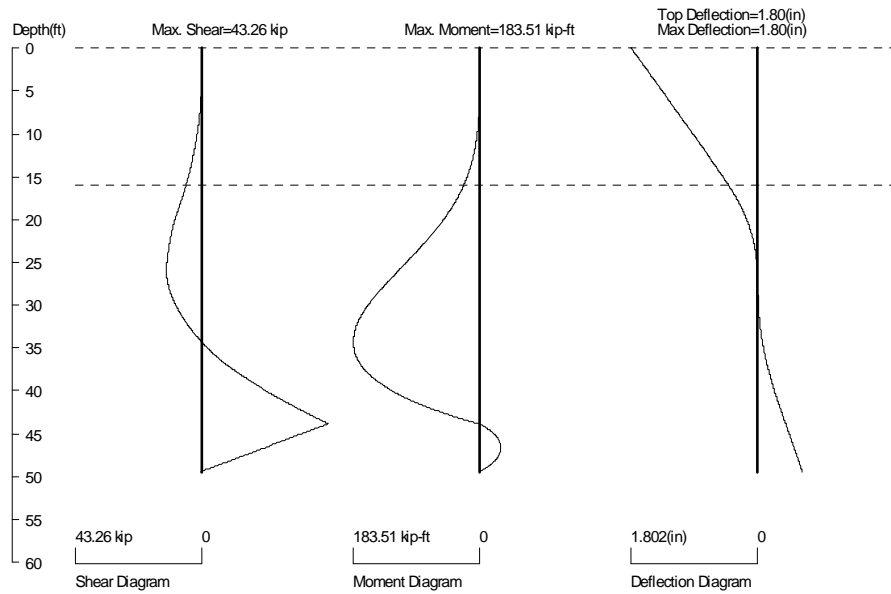
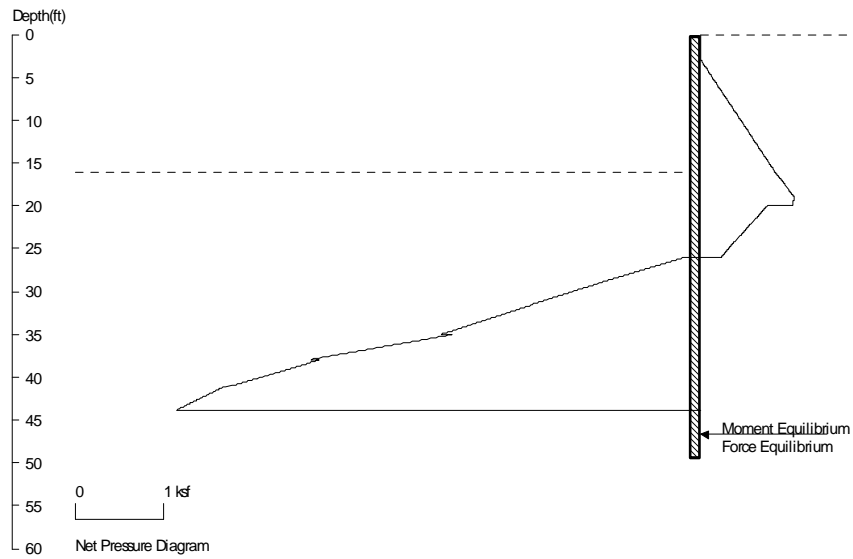

PRESSURE, SHEAR, MOMENT, AND DEFLECTION DIAGRAMS

Based on pile spacing: 1.0 foot or meter

User Input Pile, AZ38: E (ks)=29000.0, I (in⁴)/foot=637.7

File: I:\4384.0 T-117 Superfund Cleanup, Port of Seattle, WA\60%design\Sheet_Pile_Wall_Design\ShoringSuite\SheetPileWall1(5+17).sh8

<ShoringSuite> CIVILTECH SOFTWARE USA www.civiltechsoftware.com

Licensed to 4324324234 3424343

Sheet Pile Wall #1 - STA 3+80

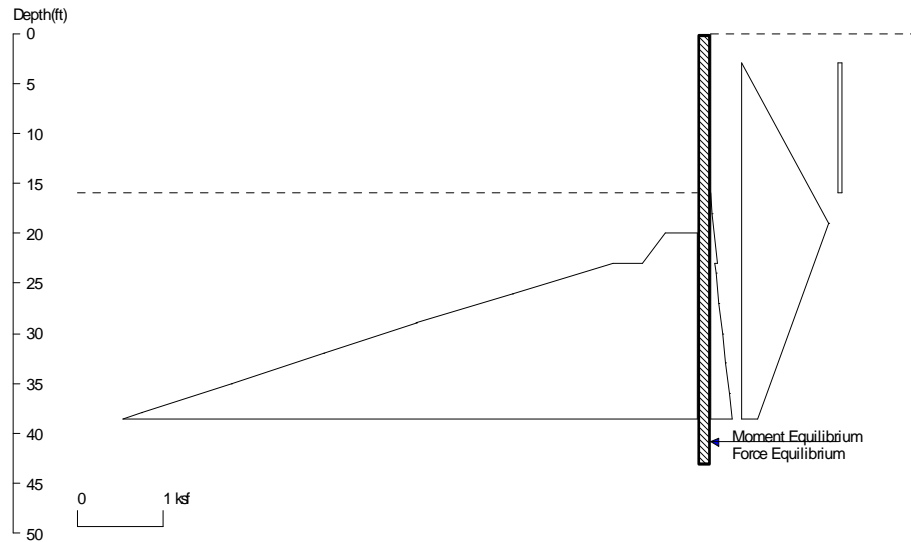

<ShoringSuite> CIVILTECH SOFTWARE USA www.civiltechsoftware.com

Licensed to 4324324234 3424343 Date: 1/31/2012

File: I:\4384.0 T- 117 Superfund Cleanup, Port of Seattle, WA\60%design\Sheet_Pile_Wall_Design\ShoringSuite\Sheet Pile

Wall Height=16.0 Pile Diameter=1.0 Pile Spacing=1.0 Wall Type: 1. Sheet Pile

PILE LENGTH: Min. Embedment=27.14 Min. Pile Length=43.14 (in graphics and analysis)

MOMENT IN PILE: Max. Moment=146.10 per Pile Spacing=1.0 at Depth=30.19

PILE SELECTION:

Request Min. Section Modulus = 53.1 in³/ft=2856.09 cm³/m, F_y= 50 ksi = 345 MPa, F_b/F_y=0.66

AZ38 has Section Modulus = 70.3 in³/ft=3779.33 cm³/m. It is greater than Min. Requirements!

Top Deflection = 1.35(in) based on E (ksi)=29000.00 and I (in⁴/foot)=637.7

DRIVING PRESSURES (ACTIVE, WATER, & SURCHARGE):

Z1	P1	Z2	P2	Slope
*	Above	Base		
0.000	0.000	16.000	0.000	0.000000
*	Below	Base		
16.000	0.000	18.000	0.020	0.010148
18.000	0.020	23.000	0.071	0.010148
23.000	0.041	24.000	0.055	0.014015
24.000	0.056	27.000	0.097	0.013811
27.000	0.097	30.000	0.138	0.013616
30.000	0.138	33.000	0.179	0.013700
33.000	0.179	36.000	0.220	0.013642
36.000	0.220	39.000	0.261	0.013642
39.000	0.261	42.000	0.302	0.013642
42.000	0.302	45.000	0.343	0.013642
*	Water	Pres.		
3.000	0.000	19.000	1.024	0.064000
19.000	1.024	Tip	0.000	To Tip
*	Wave	Pres.		
3	0.057	16	0.057	

PASSIVE PRESSURES:

Z1	P1	Z2	P2	Slope
*	Below	Base		
20.000	0.386	23.000	0.653	0.088847
23.000	0.995	26.000	2.171	0.391991
26.000	2.170	29.000	3.288	0.372519
29.000	3.280	32.000	4.367	0.362243
32.000	4.367	35.000	5.445	0.359304
35.000	5.444	38.000	6.503	0.353015
38.000	6.506	41.000	7.574	0.355962
41.000	7.574	44.000	8.640	0.355579

ACTIVE SPACING:

Nb.	Z depth	Spacing
1	0.00	1.00
2	16.00	1.00

PASSIVE SPACING:

Nb.	Z depth	Spacing
1	0.00	1.00

UNITS: Width, Spacing, Diameter, Length, and Depth - ft; Force - kip; Moment - kip-ft
Friction, Bearing, and Pressure - ksf; Pres. Slope - kip/ft³; Deflection - in

Sheet Pile Wall #1 - STA 3+80

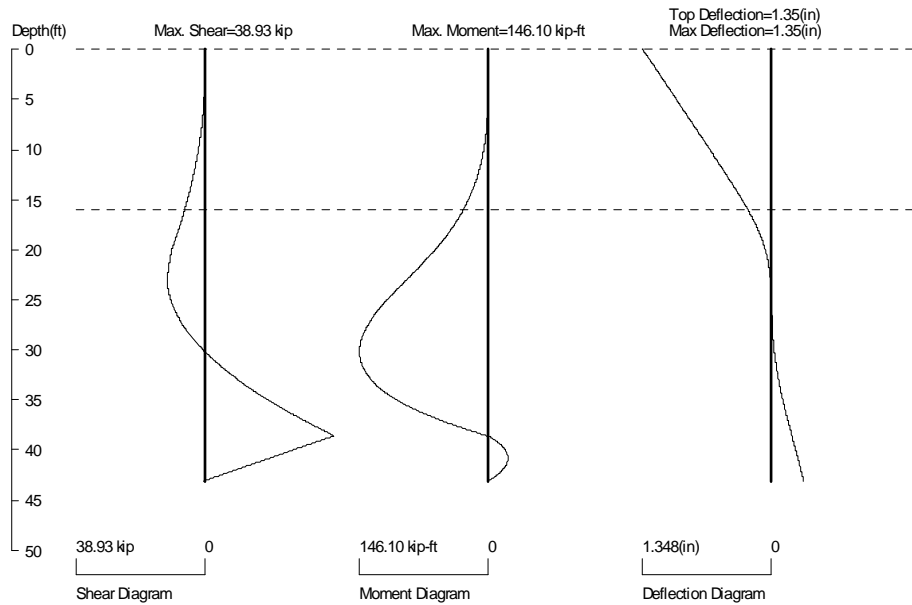
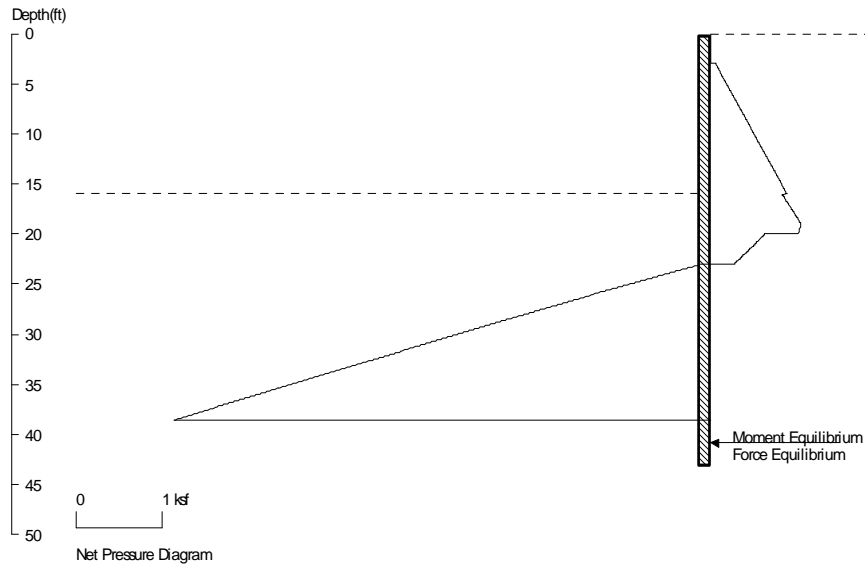

PRESSURE, SHEAR, MOMENT, AND DEFLECTION DIAGRAMS

Based on pile spacing: 1.0 foot or meter

User Input Pile, AZ38: E (ks)=29000.0, I (in⁴/foot)=637.7

File: I:\4384.0 T-117 Superfund Cleanup, Port of Seattle, WA\60%design\Sheet_Pile_Wall_Design\ShoringSuite\Sheet Pile Wall1(3+80)_WAVE.sh8

<ShoringSuite> CIVILTECH SOFTWARE USA www.civiltechsoftware.com

Licensed to 4324324234 3424343

Sheet Pile Wall #1 - STA 5+17

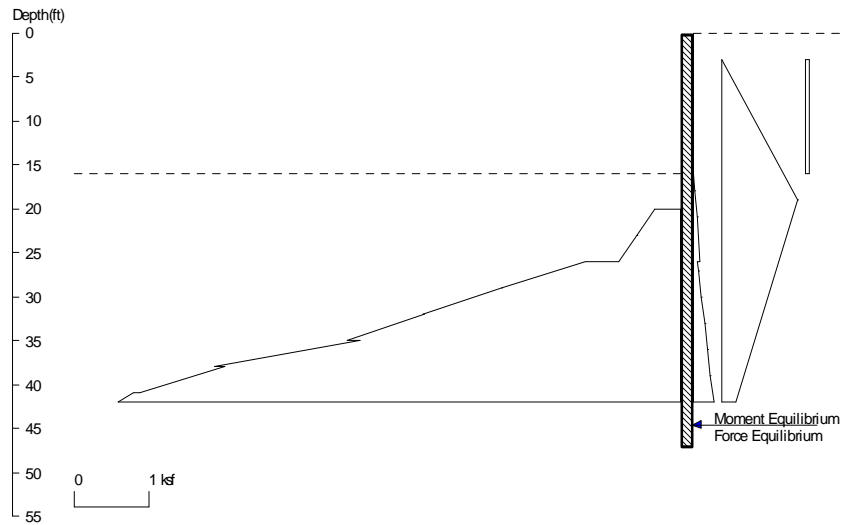

<ShoringSuite> CIVILTECH SOFTWARE USA www.civiltechsoftware.com

Licensed to 4324324234 3424343 Date: 1/31/2012

File: I:\4384.0 T-117 Superfund Cleanup, Port of Seattle, WA\60%design\Sheet_Pile_Wall_Design\ShoringSuite\SheetPileV

Wall Height=16.0 Pile Diameter=1.0 Pile Spacing=1.0 Wall Type: 1. Sheet Pile

PILE LENGTH: Min. Embedment=31.15 Min. Pile Length=47.15 (in graphics and analysis)

MOMENT IN PILE: Max. Moment=180.97 per Pile Spacing=1.0 at Depth=32.87

PILE SELECTION:

Request Min. Section Modulus = 65.8 in³/ft=3537.74 cm³/m, F_y= 50 ksi = 345 MPa, F_b/F_y=0.66

AZ38 has Section Modulus = 70.3 in³/ft=3779.33 cm³/m. It is greater than Min. Requirements!

Top Deflection = 1.75(in) based on E (ksi)=29000.00 and I (in⁴)/foot=637.7

DRIVING PRESSURES (ACTIVE, WATER, & SURCHARGE):

Z1	P1	Z2	P2	Slope
*	Above	Base		
0.000	0.000	16.000	0.000	0.000000
*	Below	Base		
16.000	0.000	18.000	0.020	0.009998
18.000	0.020	21.000	0.050	0.009998
21.000	0.050	26.000	0.100	0.009998
26.000	0.059	27.000	0.072	0.013399
27.000	0.073	30.000	0.114	0.013743
30.000	0.114	33.000	0.154	0.013547
33.000	0.154	36.000	0.195	0.013727
36.000	0.195	39.000	0.236	0.013475
39.000	0.236	42.000	0.276	0.013475
42.000	0.276	46.000	0.330	0.013475
46.000	0.358	48.000	0.386	0.014127
*	Water	Pres.		
3.000	0.000	19.000	1.024	0.064000
19.000	1.024	Tip	0.000	To Tip
*	Wave	Pres.		

3	.057	16	0.057	
PASSIVE PRESSURES:				
Z1	P1	Z2	F2	Slope
*	Below	Base		
20.000	0.349	23.000	0.586	0.078827
23.000	0.586	26.000	0.822	0.078827
26.000	1.275	29.000	2.393	0.372462
29.000	2.387	32.000	3.437	0.350105
32.000	3.429	35.000	4.454	0.341828
35.000	4.278	38.000	6.233	0.651401
38.000	6.085	41.000	7.231	0.382082
41.000	7.317	46.000	8.399	0.216495
46.000	7.070	47.000	7.273	0.203188
47.000	7.272	50.000	7.874	0.200738
ACTIVE SPACING:				
Nb.		Z depth		Spacing
1		0.00		1.00
2		16.00		1.00
PASSIVE SPACING:				
Nb.		Z depth		Spacing
1		0.00		1.00

UNITS: Width, Spacing, Diameter, Length, and Depth - ft; Force - kip; Moment - kip-ft
Friction, Bearing, and Pressure - ksf; Pres. Slope - kip/ft³; Deflection - in

Sheet Pile Wall #1 - STA 5+17

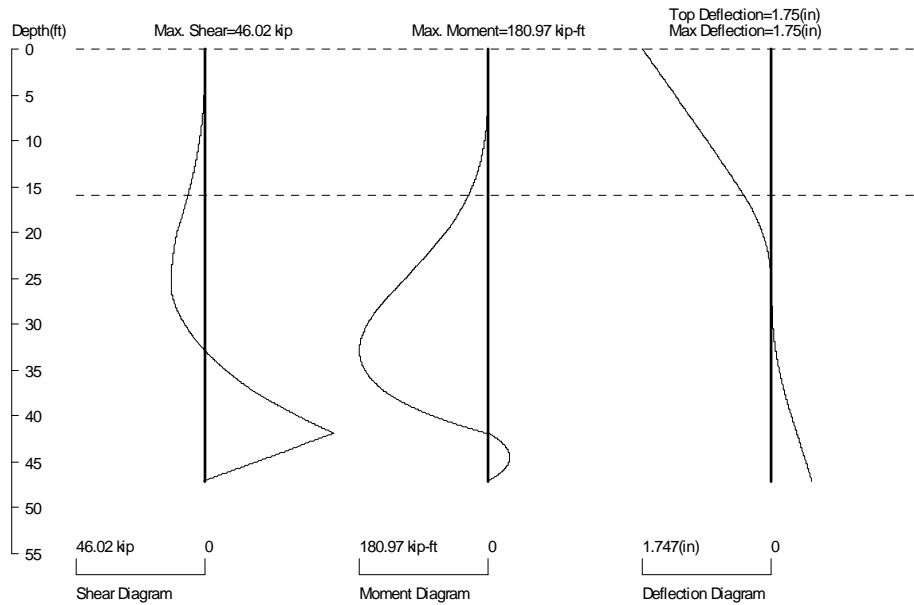
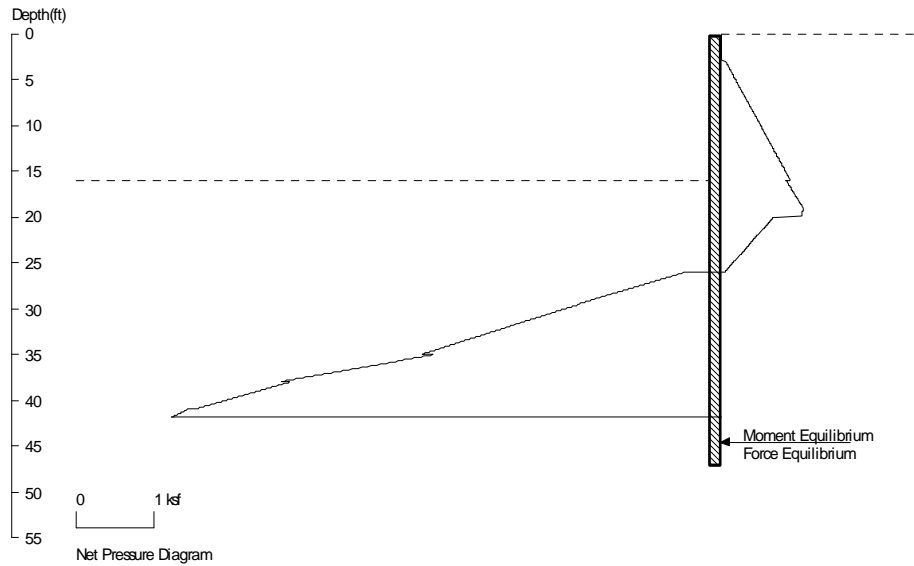

PRESSURE, SHEAR, MOMENT, AND DEFLECTION DIAGRAMS

Based on pile spacing: 1.0 foot or meter

User Input Pile, AZ38: E (ks)=29000.0, I (in⁴/foot)=637.7

File: I:\4384.0 T-117 Superfund Cleanup, Port of Seattle, WA\60%design\Sheet_Pile_Wall_Design\ShoringSuite\SheetPileWall1(5+17)_WAVE.sh8

<ShoringSuite> CIVILTECH SOFTWARE USA www.civiltechsoftware.com

Licensed to 4324324234 3424343

Sheet Pile Wall #2 - North Wing Wall

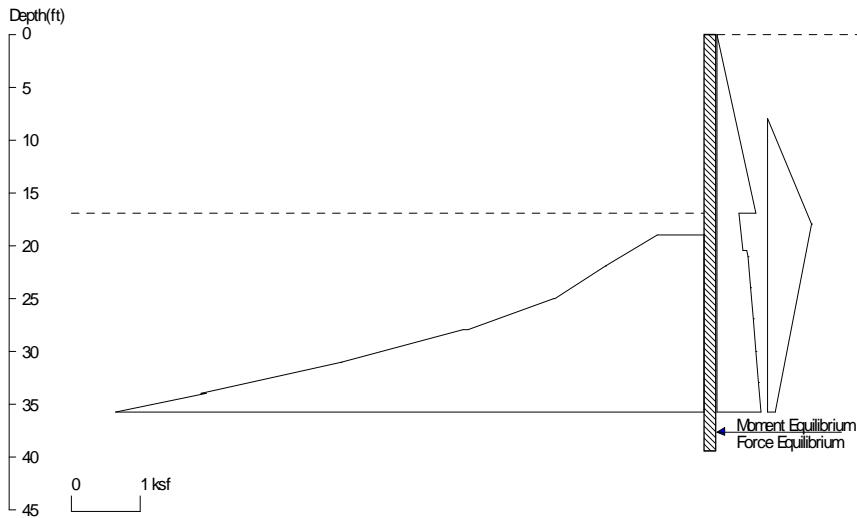

<ShoringSuite> CIVILTECH SOFTWARE USA www.civiltechsoftware.com

Licensed to KOH Jacobs Date: 2/2/2012

File: I:\4384.0 T- 117 Superfund Cleanup, Port of Seattle, WA\60%design\Sheet_Pile_Wall_Design\ShoringSuite\Sheet Pile

Wall Height=17.0 Pile Diameter=1.0 Pile Spacing=1.0 Wall Type: 1. Sheet Pile

PILE LENGTH: Min. Embedment=22.47 Min. Pile Length=39.47 (in graphics and analysis)
 MOMENT IN PILE: Max. Moment=117.56 per Pile Spacing=1.0 at Depth=28.36

PILE SELECTION:

Request Min. Section Modulus = 42.8 in³/ft=2298.27 cm³/m, Fy= 50 ksi = 345 MPa, Fb/Fy=0.66
 AZ38 has Section Modulus = 70.3 in³/ft=3779.33 cm³/m. It is greater than Min. Requirements!
 Top Deflection = 1.20(in) based on E (ksi)=29000.00 and I (in⁴)/foot=637.7

DRIVING PRESSURES (ACTIVE, WATER, & SURCHARGE):

Z1	P1	Z2	P2	Slope
*	Above	Base		
0.000	0.000	17.000	0.571	0.033583
*	Below	Base		
17.000	0.334	20.500	0.388	0.015385
20.500	0.441	21.000	0.447	0.012829
21.000	0.447	24.000	0.486	0.012829
24.000	0.486	27.000	0.524	0.012829
27.000	0.524	30.000	0.563	0.012829
30.000	0.563	33.000	0.602	0.013122
33.000	0.602	36.000	0.641	0.012841
36.000	0.641	39.000	0.679	0.012841
39.000	0.679	42.000	0.718	0.012841
*	Water	Pres.		
8.000	0.000	18.000	0.640	0.064000
18.000	0.640	Tip	0.000	To Tip

PASSIVE PRESSURES:

Z1	P1	Z2	P2	Slope
*	Below	Base		

19.000	0.680	22.000	1.417	0.245610
22.000	1.416	25.000	2.149	0.244212
25.000	2.163	28.000	3.406	0.414112
28.000	3.477	31.000	5.247	0.590245
31.000	5.245	34.000	7.273	0.675912
34.000	7.183	37.000	9.490	0.768964
37.000	9.742	40.500	10.653	0.260175

ACTIVE SPACING:

No.	Z depth	Spacing
1	0.00	1.00
2	17.00	1.00

PASSIVE SPACING:

No.	Z depth	Spacing
1	0.00	1.00

UNITS: Width, Spacing, Diameter, Length, and Depth - ft; Force - kip; Moment - kip-ft
 Friction, Bearing, and Pressure - ksf; Pres. Slope - kip/ft³; Deflection - in

Sheet Pile Wall #2 - North Wing Wall

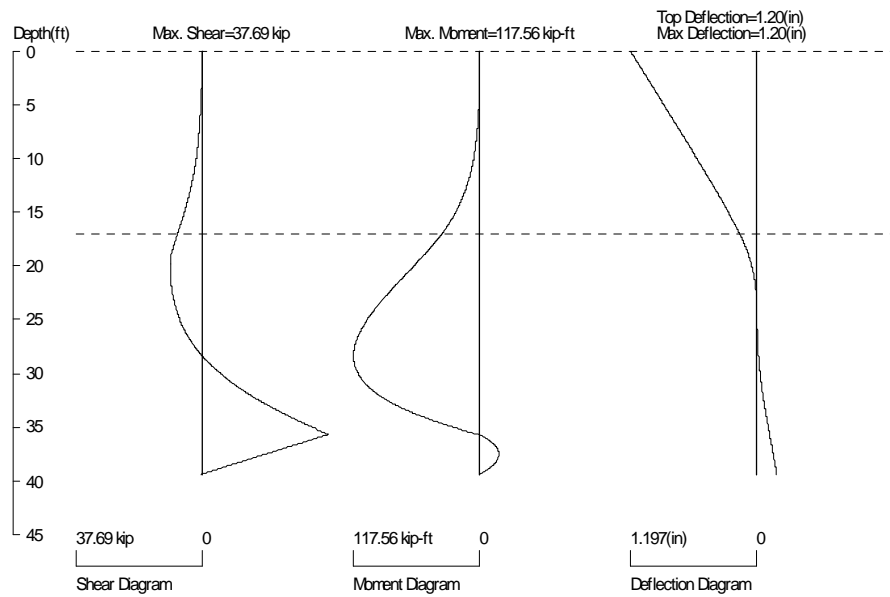
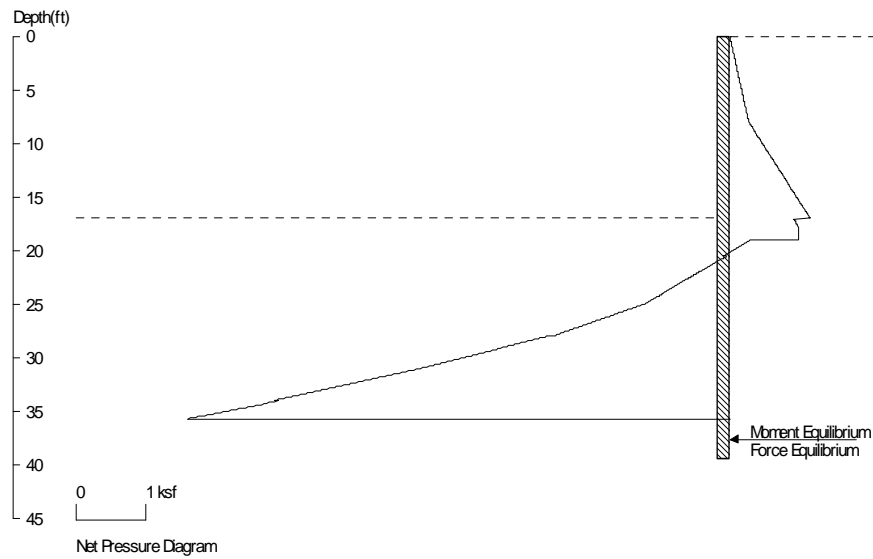

PRESSURE, SHEAR, MOMENT, AND DEFLECTION DIAGRAMS

Based on pile spacing: 1.0 foot or meter

User Input File, AZ38: E(ksi)=29000.0, I(in⁴)/foot=637.7

File: I:\4384.0 T-117 Superfund Cleanup, Port of Seattle, WA\60%design\Sheet_Pile_Wall_Design\ShoringSuite\Sheet Pile Wall2_NorthWingWall.sh8

<ShoringSuite> CIVILTECH SOFTWARE USA www.civiltechsoftware.com

Licensed to KOH Jacobs

Sheet Pile Wall #3 - South Wing Wall

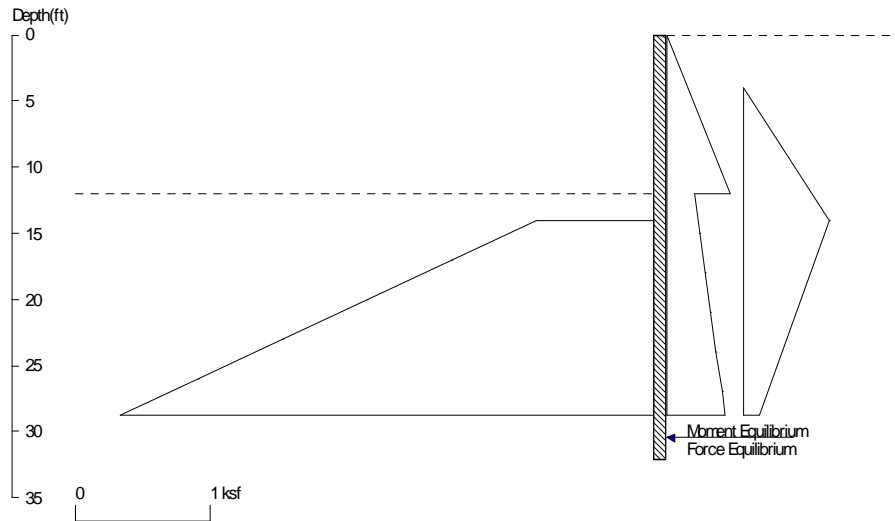

<ShoringSuite> CIVILTECH SOFTWARE USA www.civiltechsoftware.com

Licensed to KOH Jacobs Date: 8/16/2012
 File: I:\4384.0 T- 117 Superfund Cleanup, Port of Seattle, WA\60%design\Sheet_Pile_Wall_Design\ShoringSuite\SPW3 Sou

Wall Height=12.0 Pile Diameter=1.0 Pile Spacing=1.0 Wall Type: 1. Sheet Pile

PILE LENGTH: Min. Embedment=20.16 Min. Pile Length=32.16 (in graphics and analysis)
 MOMENT IN PILE: Max. Moment=60.71 per Pile Spacing=1.0 at Depth=21.51

PILE SELECTION:

Request Min. Section Modulus = 22.1 in³/ft=1186.75 cm³/m, Fy= 50 ksi = 345 MPa, Fb/Fy=0.66
 AZ38 has Section Modulus = 70.3 in³/ft=3779.33 cm³/m. It is greater than Min. Requirements!
 Top Deflection = 0.43(in) based on E (ksi)=29000.00 and I (in⁴/foot)=637.7

DRIVING PRESSURES (ACTIVE, WATER, & SURCHARGE):

Z1	P1	Z2	P2	Slope
*	Above	Base		
0.000	0.000	12.000	0.473	0.039436
*	Below	Base		
12.000	0.208	15.000	0.250	0.013706
15.000	0.249	18.000	0.291	0.014019
18.000	0.290	21.000	0.330	0.013389
21.000	0.330	24.000	0.372	0.014030
24.000	0.372	27.000	0.412	0.013468
27.000	0.412	30.000	0.453	0.013468
30.000	0.453	33.000	0.493	0.013468
*	Water	Pres.		
4.000	0.000	14.000	0.640	0.064000
14.000	0.640	Tip	0.000	To Tip

PASSIVE PRESSURES:

Z1	P1	Z2	P2	Slope
*	Below	Base		
14.000	0.869	17.000	1.497	0.209354

17.000	1.497	20.000	2.125	0.209353
20.000	2.125	23.000	2.753	0.209353
23.000	2.753	26.000	3.381	0.209353
26.000	3.381	29.000	4.009	0.209353
29.000	4.009	32.000	4.638	0.209353
32.000	4.638	35.000	5.266	0.209353

ACTIVE SPACING:

No.	Z depth	Spacing
1	0.00	1.00
2	12.00	1.00

PASSIVE SPACING:

No.	Z depth	Spacing
1	0.00	1.00

UNITS: Width, Spacing, Diameter, Length, and Depth - ft; Force - kip; Moment - kip-ft
 Friction, Bearing, and Pressure - ksf; Pres. Slope - kip/ft³; Deflection - in

Sheet Pile Wall #3 - South Wing Wall

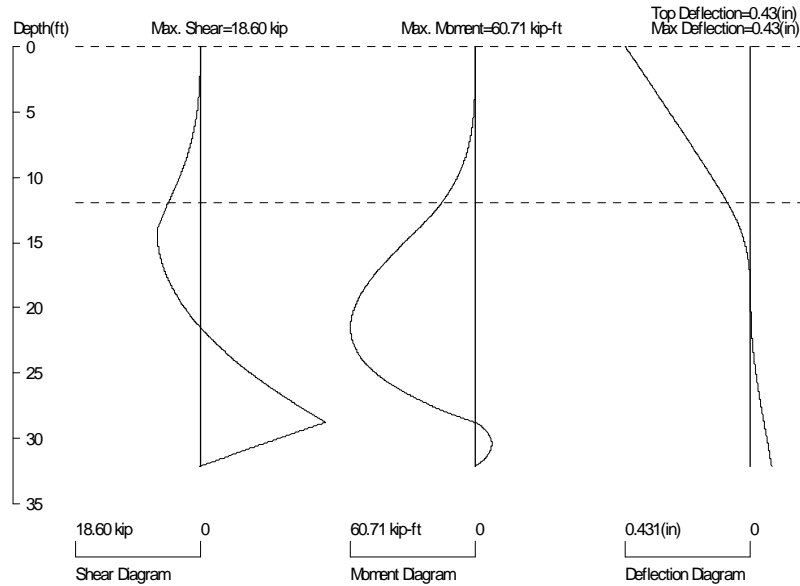
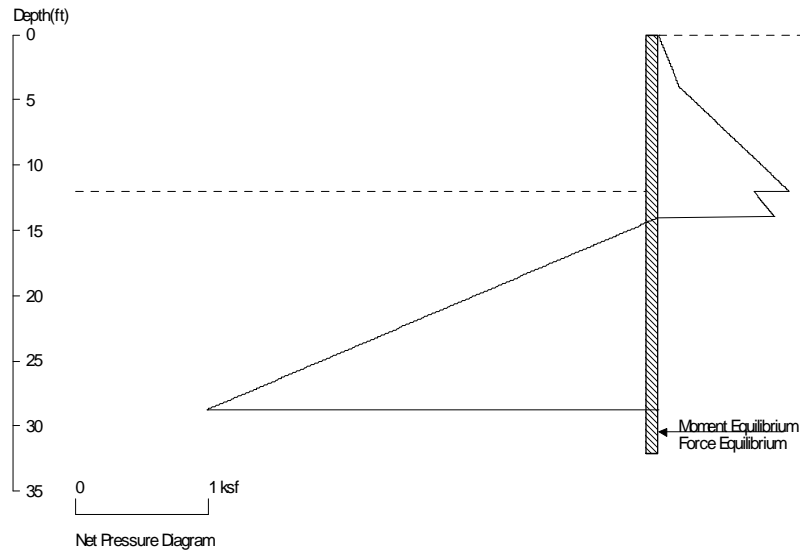

PRESSURE, SHEAR, MOMENT, AND DEFLECTION DIAGRAMS

Based on pile spacing: 1.0 foot or meter

User Input File, AZ38: E(ksi)=29000.0, I(in⁴)/foot=637.7

File: I:\4384.0 T-117 Superfund Cleanup, Port of Seattle, WA\609\design\Sheet_Pile_Wall_Design\ShoringSuite\SPW3 SouthWingWall2 - 08162012.sh8

<ShoringSuite> CIVILTECH SOFTWARE USA www.civiltechsoftware.com

Licensed to KOH Jacobs

Sheet Pile Wall #3 - South Wing Wall

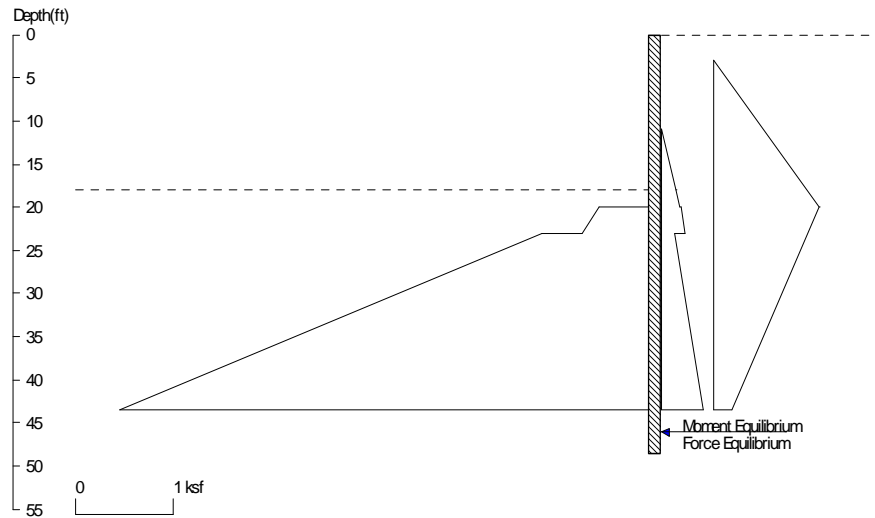

<ShoringSuite> CIVILTECH SOFTWARE USA www.civiltechsoftware.com

Licensed to KOH Jacobs Date: 2/2/2012
 File: I:\4384.0 T-117 Superfund Cleanup, Port of Seattle, WA\60%design\Sheet_Pile_Wall_Design\ShoringSuite\Sheet Pile

Wall Height=18.0 Pile Diameter=1.0 Pile Spacing=1.0 Wall Type: 1. Sheet Pile

PILE LENGTH: Min. Embedment=30.62 Min. Pile Length=48.62 (in graphics and analysis)
 MOMENT IN PILE: Max. Moment=170.32 per Pile Spacing=1.0 at Depth=33.17

PILE SELECTION:

Request Min. Section Modulus = 61.9 in³/ft=3329.66 cm³/m, Fy= 50 ksi = 345 MPa, Fb/Fy=0.66
 AZ38 has Section Modulus = 70.3 in³/ft=3779.33 cm³/m. It is greater than Min. Requirements!
 Top Deflection = 2.23(in) based on E (ksi)=29000.00 and I (in⁴/foot)=637.7

DRIVING PRESSURES (ACTIVE, WATER, & SURCHARGE):

Z1	P1	Z2	P2	Slope
*	Above	Base		
11.000	0.000	18.000	0.144	0.020623
*	Below	Base		
18.000	0.144	20.000	0.186	0.020623
20.000	0.208	23.000	0.240	0.010729
23.000	0.141	53.000	0.572	0.014359
*	Water	Pres.		
3.000	0.000	20.000	1.088	0.064000
20.000	1.088	Tip	0.000	To Tip

PASSIVE PRESSURES:

Z1	P1	Z2	P2	Slope
*	Below	Base		
20.000	0.513	23.000	0.684	0.056831
23.000	1.103	53.000	7.440	0.211224

ACTIVE SPACING:

No.	Z depth	Spacing
1	0.00	1.00
2	18.00	1.00

PASSIVE SPACING:

No.	Z depth	Spacing
1	0.00	1.00

UNITS: Width, Spacing, Diameter, Length, and Depth - ft; Force - kip; Moment - kip-ft
Friction, Bearing, and Pressure - ksf; Pres. Slope - kip/ft³; Deflection - in

Sheet Pile Wall #3 - South Wing Wall

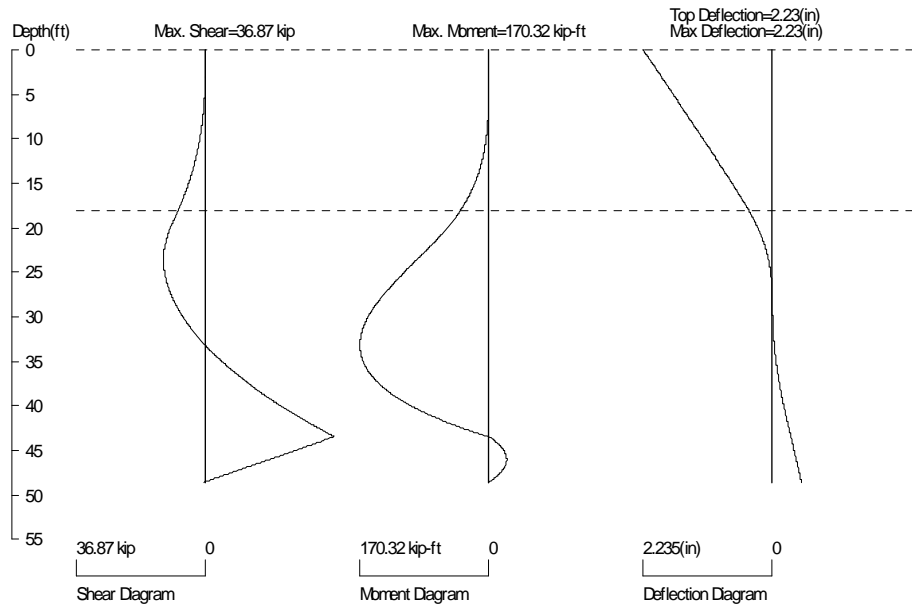
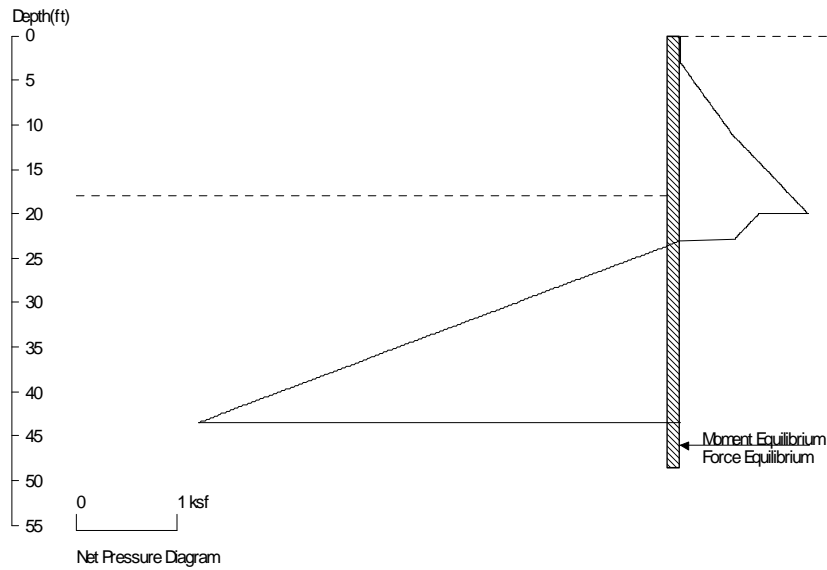

PRESSURE, SHEAR, MOMENT, AND DEFLECTION DIAGRAMS

Based on pile spacing: 1.0 foot or meter

User Input File, AZ38: E(ksi)=29000.0, I(in⁴)/foot=637.7

File: I:\4384.0 T-117 Superfund Cleanup, Port of Seattle, WA\60%design\Sheet_Pile_Wall_Design\ShoringSuite\Sheet Pile Wall3_SouthWingWall1b.sh8

<ShoringSuite> CIVILTECH SOFTWARE USA www.civiltechsoftware.com

Licensed to KOH Jacobs